

36472270

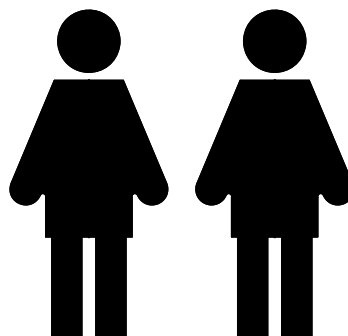
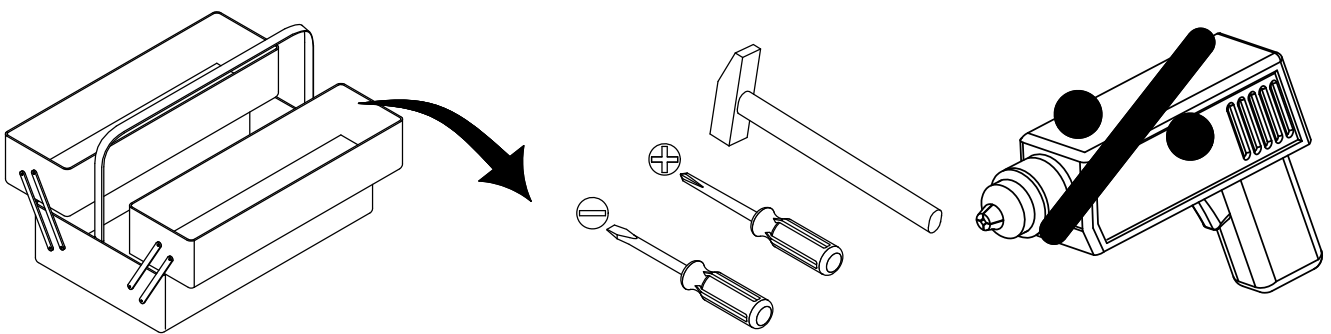
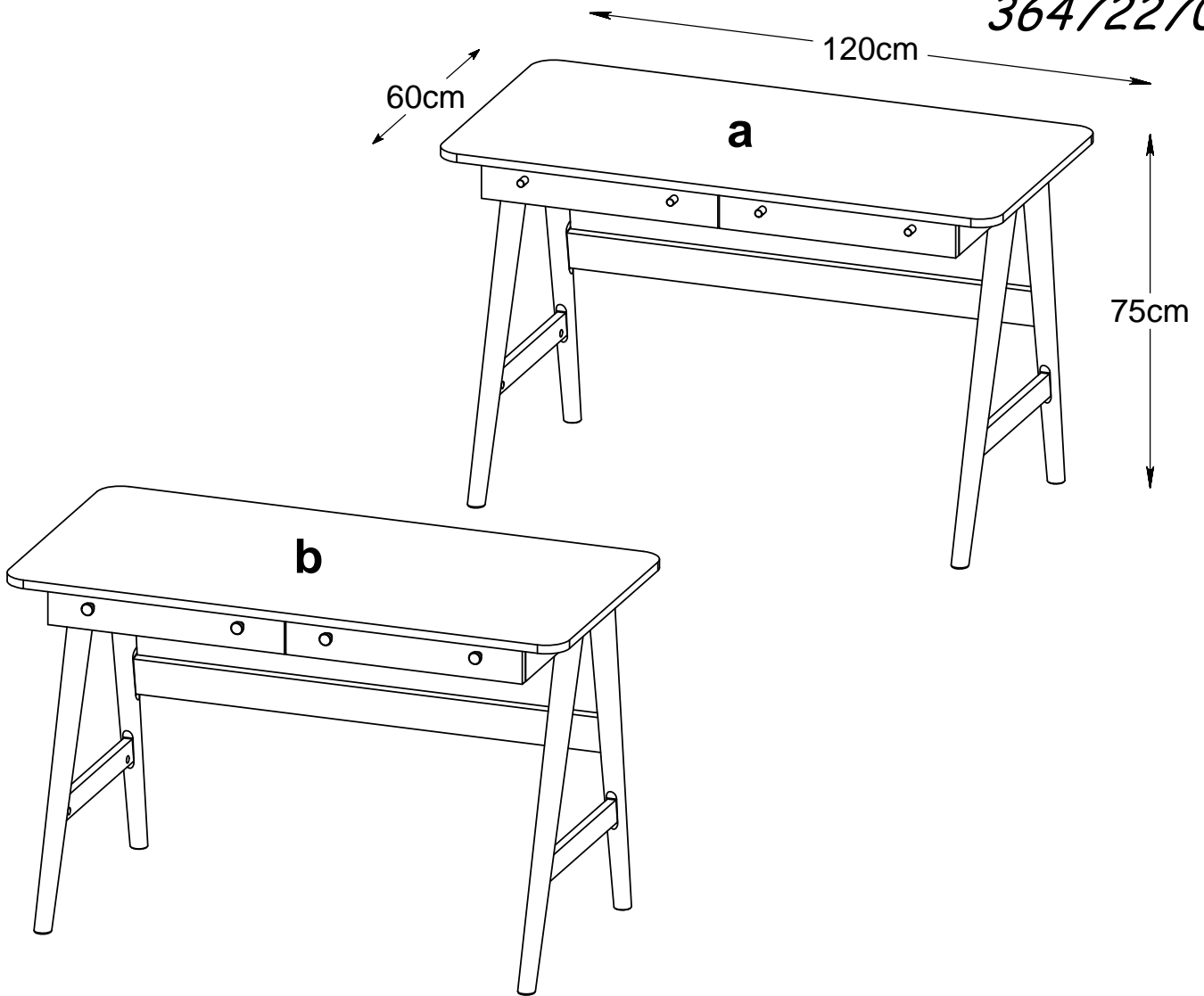

WICHTIG - FÜR SPÄTERE VERWENDUNG
AUFBEWAHREN - SORGFÄLTIG LESEN

IMPORTANTE, conservare per utilizzi futuri,
leggere attentamente.

VIGTIGT - Samlevejledningen skal opbevares
i arkiv til senere brug - Skal gennemlæses nøje

NOTICE - These instructions must be saved
for future use - Instructions must be followed

IMPORTANT - Veuillez conserver
la notice de montage dans le cadre
d'une prochaine utilisation.
Parcourir cette notice avec attention

TEILCHECKLISTE
 DISTINTA DELLE PARTI
 TJEKLISTE
 CHECK LIST
 LISTE DE CONTROLE

Réf./No.	Réf./Art.	Qty./Stck./Quantité	Size / Maß / Dimension (mm)	Qty./Stck./Quantité	✓
1	325962227	1	1200x600x98		
2	32596305	1	795xØ55		
3	32596405	1	795xØ55		
4	32596505	1	751xØ55		
5	32596605	1	751xØ55		
6	32596705	1	400x50x18		
7	32596805	1	400x50x18		
8	32596905	1	995x80x18		

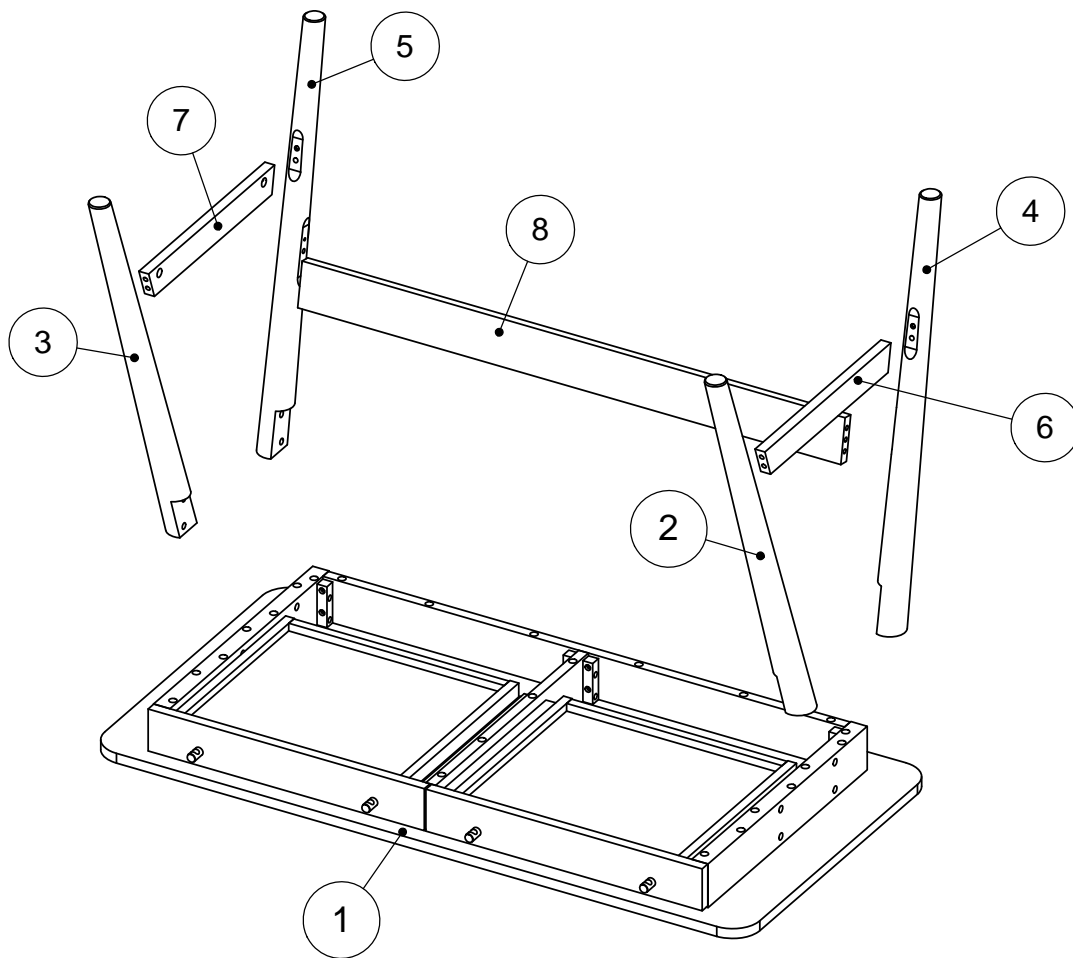

Sollten Sie eventuelle Ersatzteile
 oder Reklamationsteile fordern,
 dann bitten wir Sie, diese Seite
 mitzubringen.

Per richiedere eventuali parti
 di ricambio o di sostituzione,
 La invitiamo a presentare questa pagina.

Skulle de få brug for reklamationstele,
 beder vi dem medsende denne side

If you should be in the need of spareparts,
 please enclose this page.

En cas de service apres - vente, veuillez nous
 retourner ce coupon

Name/Name/Navn/Nom: _____

Adresse/Indirizzo/Address: _____

PLZ/CAP/Post.nr/Postal code: _____

Telefon/Telefono/Téléphone: _____

Oberfläche/Superficie/
 Behandlung/Treatment/Finition: _____





No./Référence: _____

Ursache/Causa/
 Årsag/Reason/Motif: _____

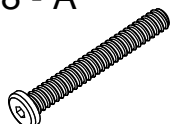
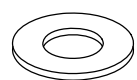

TEILCHECKLISTE - DISTINTA DELLE PARTI - TJEKLISTE - CHECK LIST - LISTE DE CONTROLE

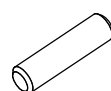
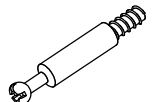
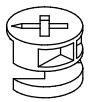
Réf./No.	Réf./Art.	Qty./Stck./Quantité	✓
A	225971	8	
B	225971	8	
C	225971	8	
D	225971	1	
E	225971	6	
F	225971	8	
G	225971	8	
H	225971	8	
J	32605105	4	

<p>8 - A</p>  <p>M8x50mm</p>	<p>8 - B</p>  <p>M8x20mm</p>	<p>8 - C</p>  <p>M8mm</p>	<p>1 - D</p>  <p>5mm</p>	<p>6 - E</p>  <p>Ø8x30mm</p>	<p>8 - F</p>  <p>Ø6x44mm</p>
<p>8 - G</p>  <p>Ø15x12mm</p>	<p>8 - H</p> 	<p>4 - J</p>  <p>Ø25x25mm</p>			

Geehrter Kunde.
Hier haben Sie die Möglichkeit die mitgelieferten Schrauben nachzumessen.

Egregio cliente,
Controllare le misure delle viti fornite in dotazione.

Kære kunde.
Her har De muligheden for at måle medsendte beslag.

Dear Customer.
Below you have the opportunity to measure the Enclosed Hardware.

Cher Client.
La règle ci jointe vous permet de mesurer la visserie.

Name/Name/Navn/Nom: _____

Adresse/Indirizzo/Address: _____

PLZ/CAP/Post.nr/Postal code: _____

Telefon/Telefono/Téléphone: _____

Oberfläche/Superficie/
Behandling/Treatment/Finition: _____

No./Référence: _____

Ursache/Causa/
Årsag/Reason/Motif: _____

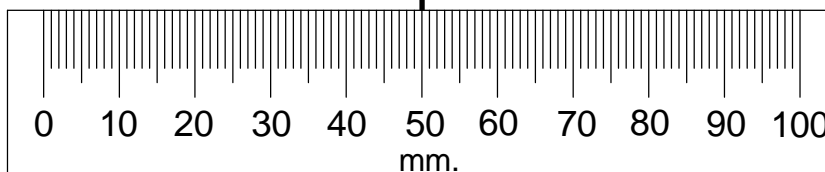

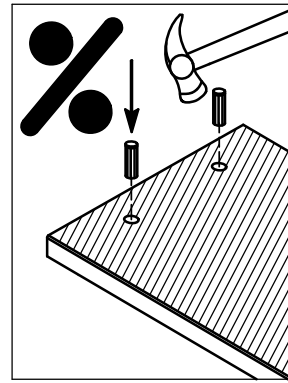
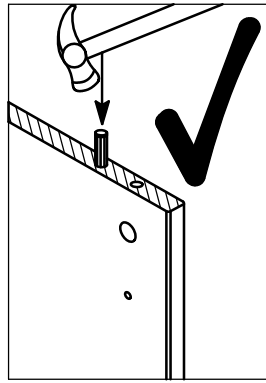

1

6 - E

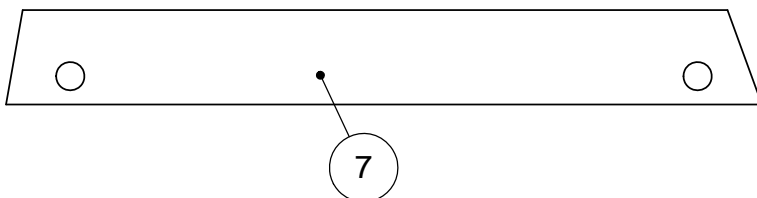
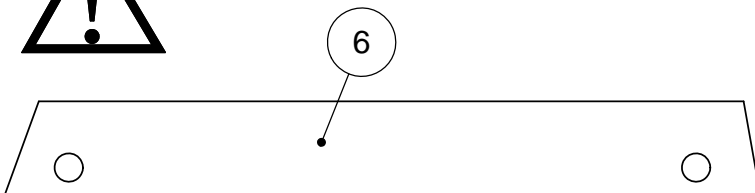
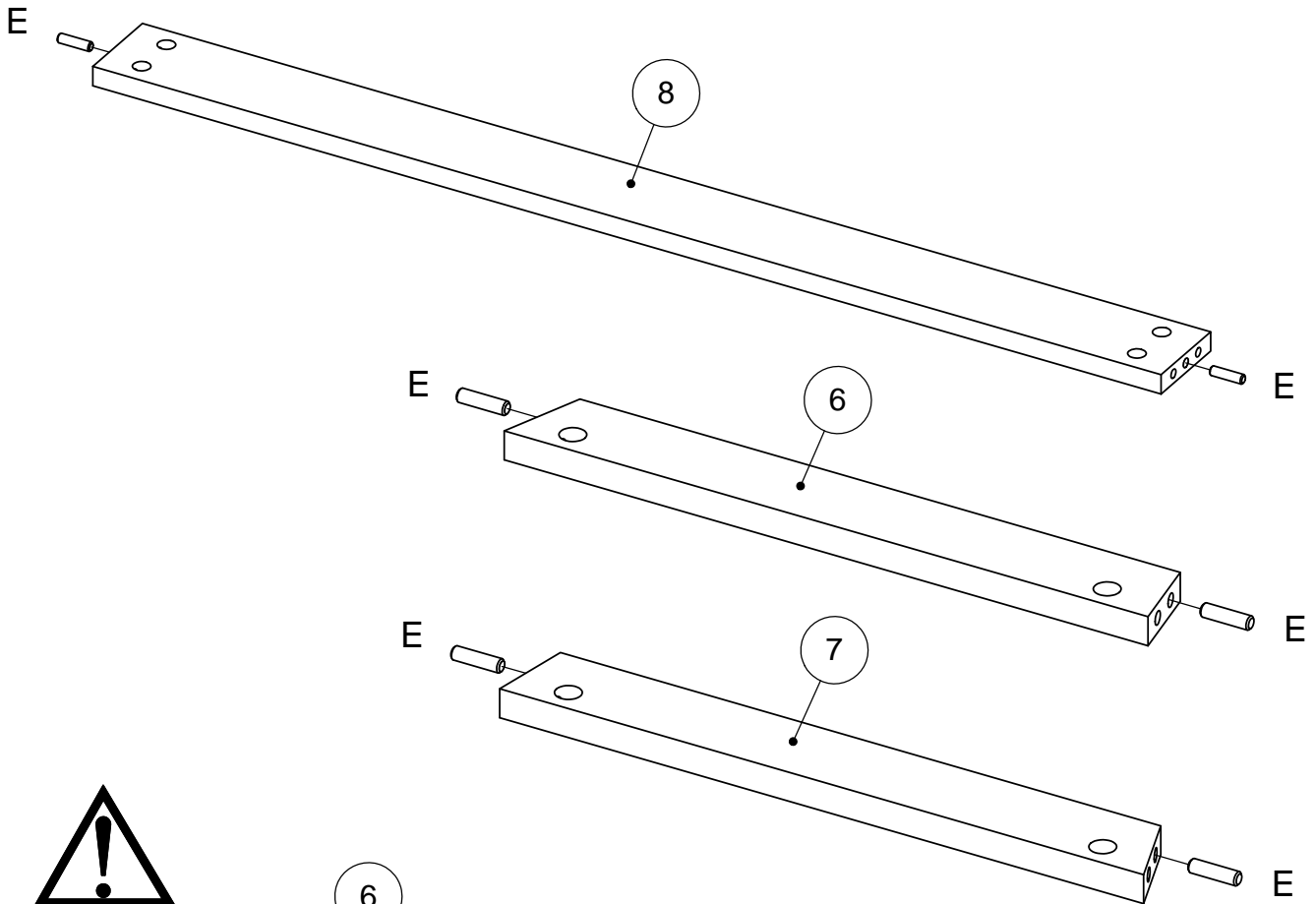
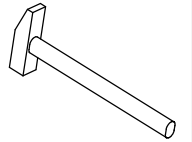
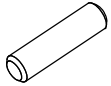

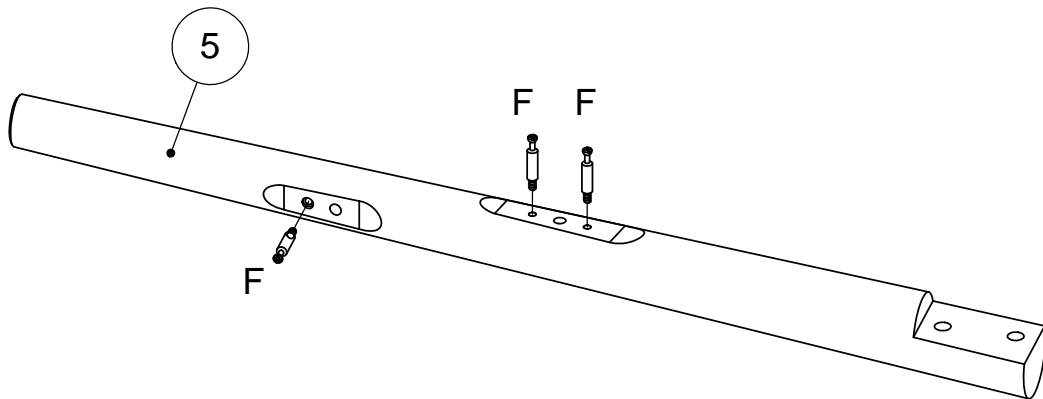
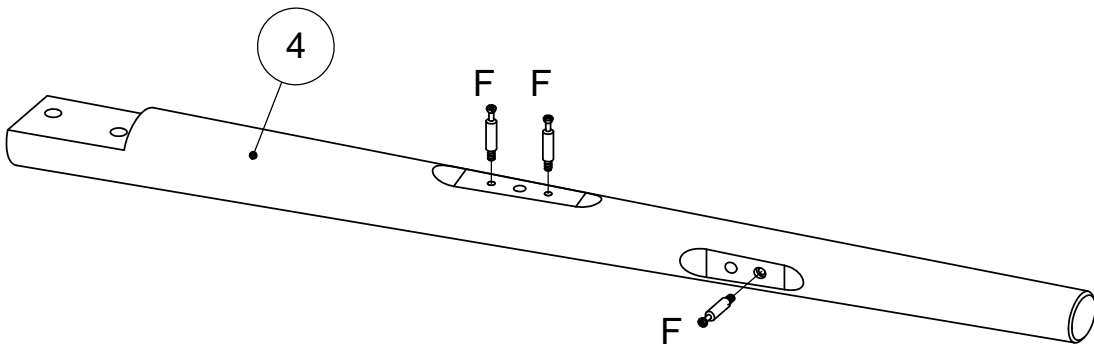
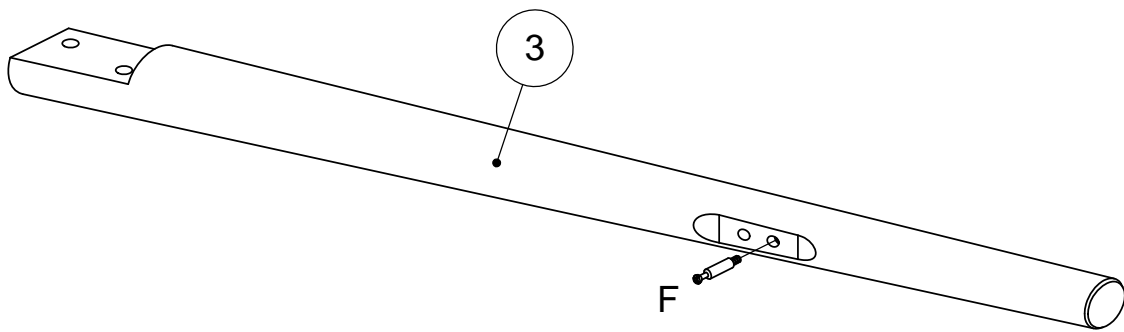
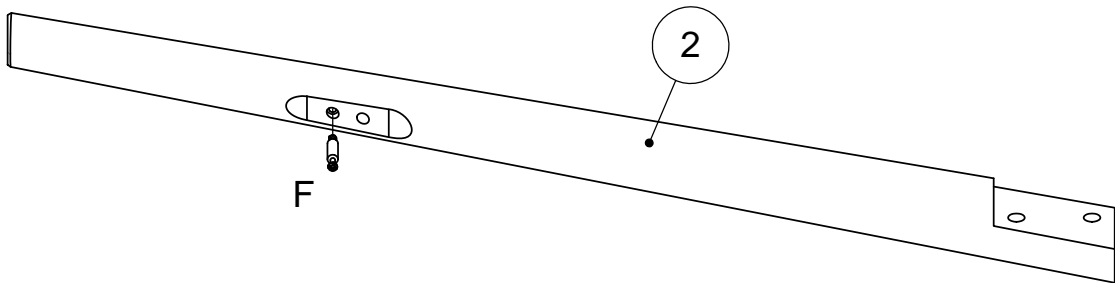

3
4 - G
4 - H



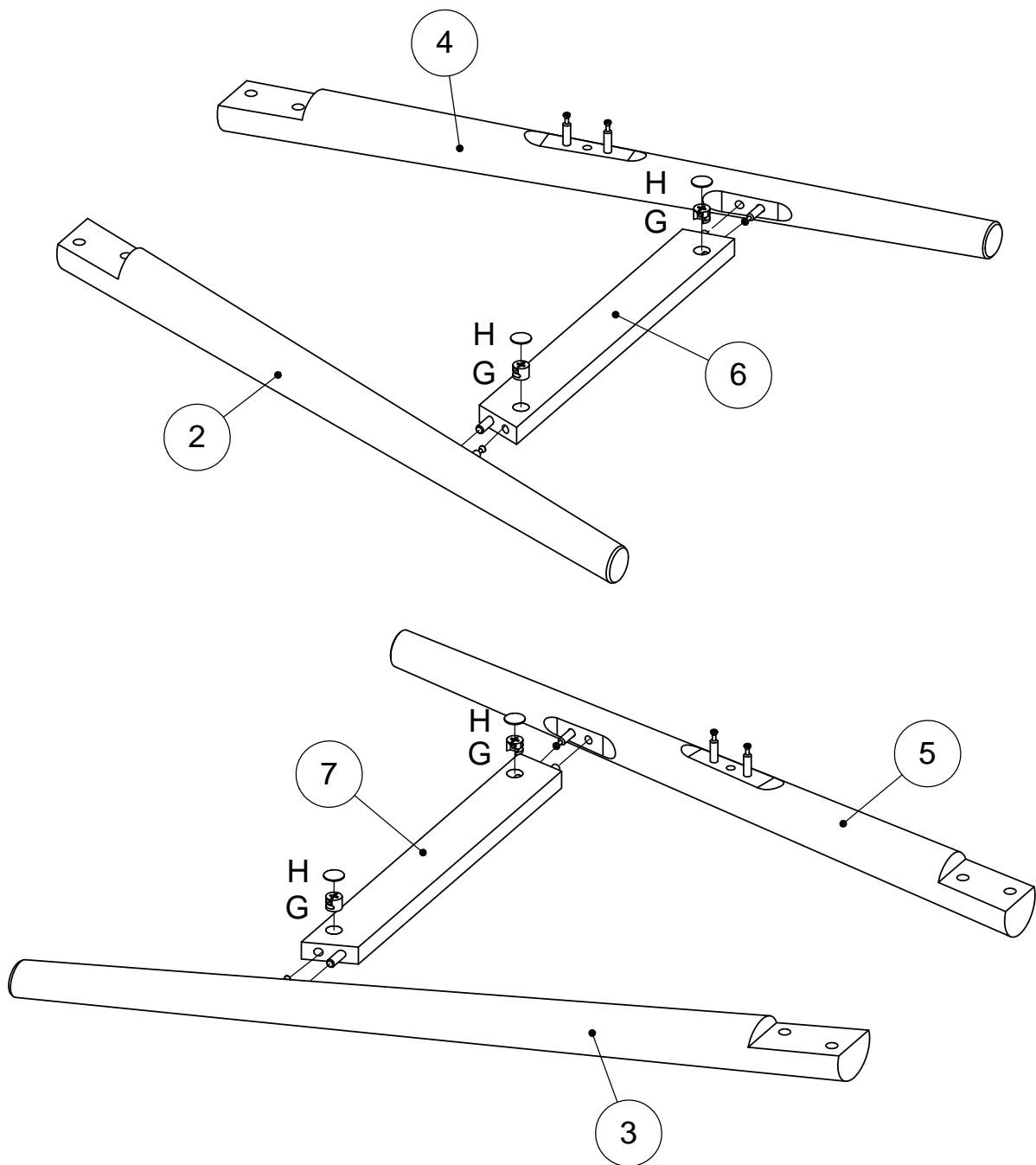
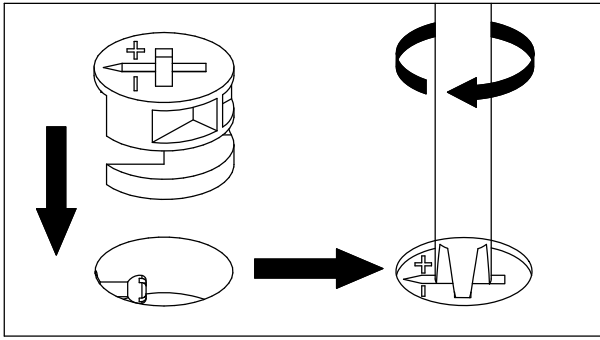

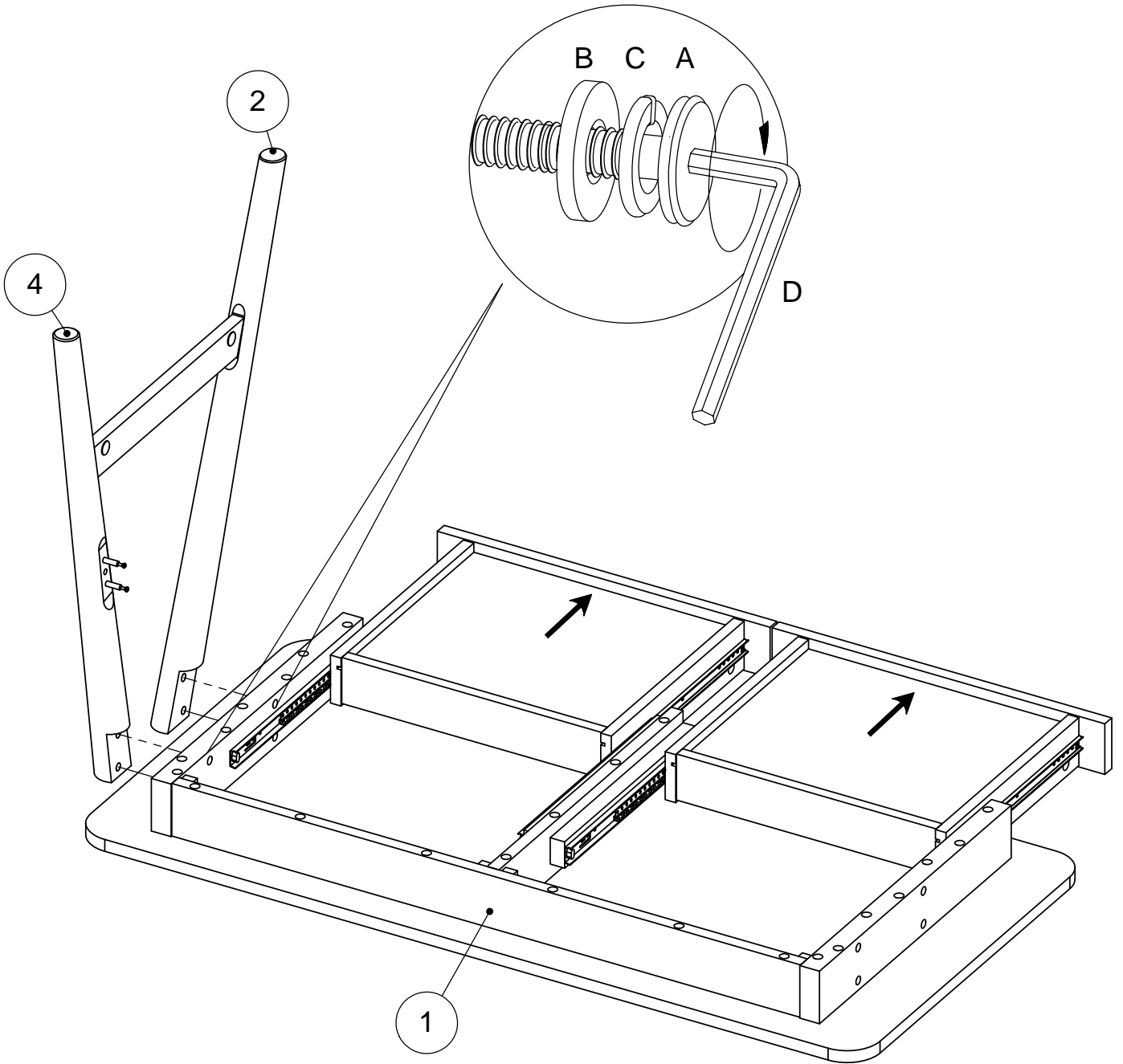
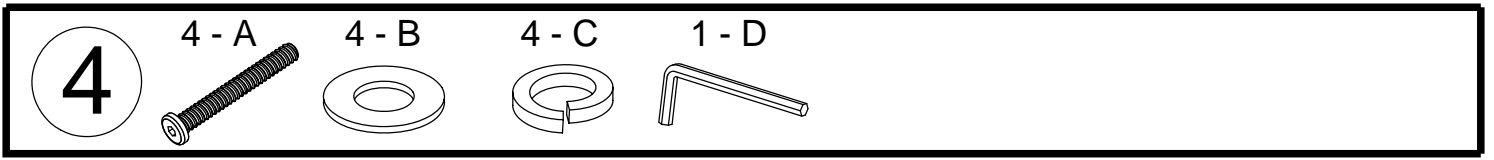

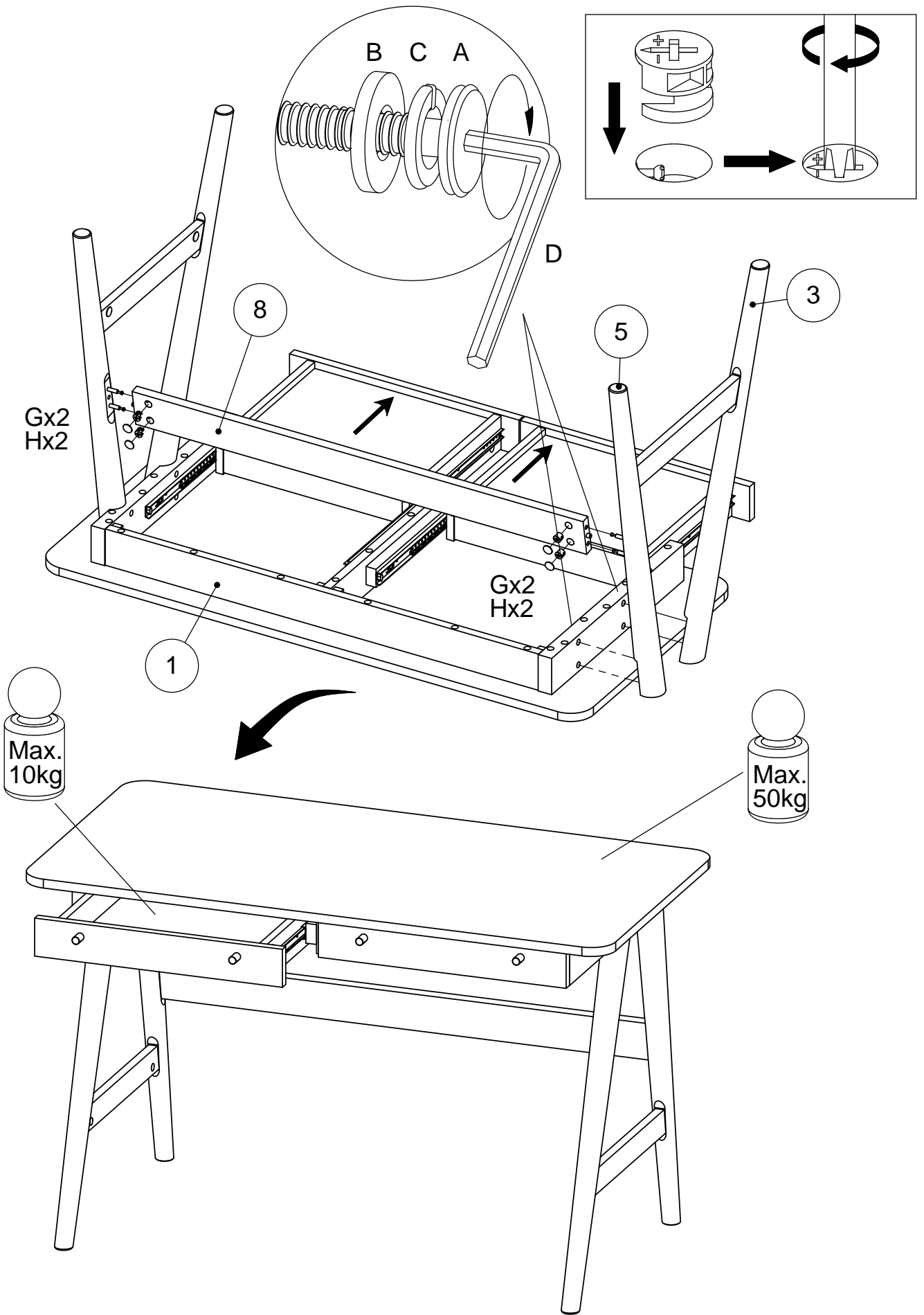
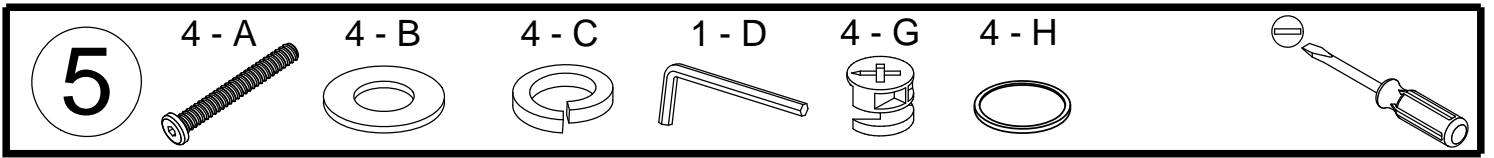

a

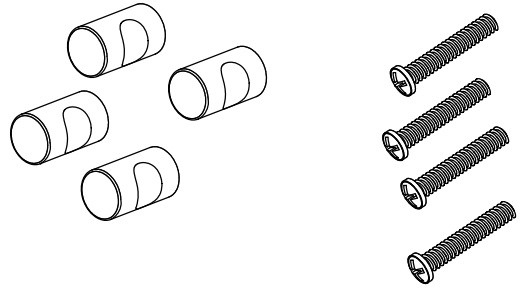
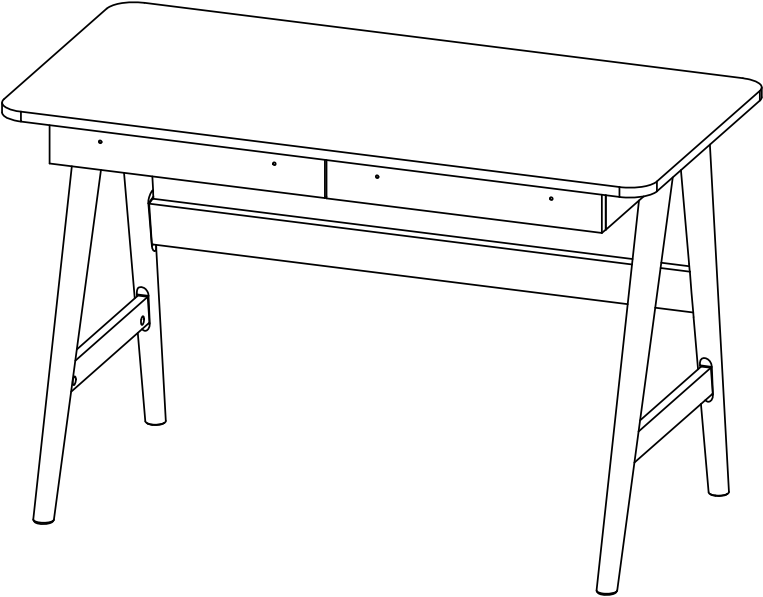
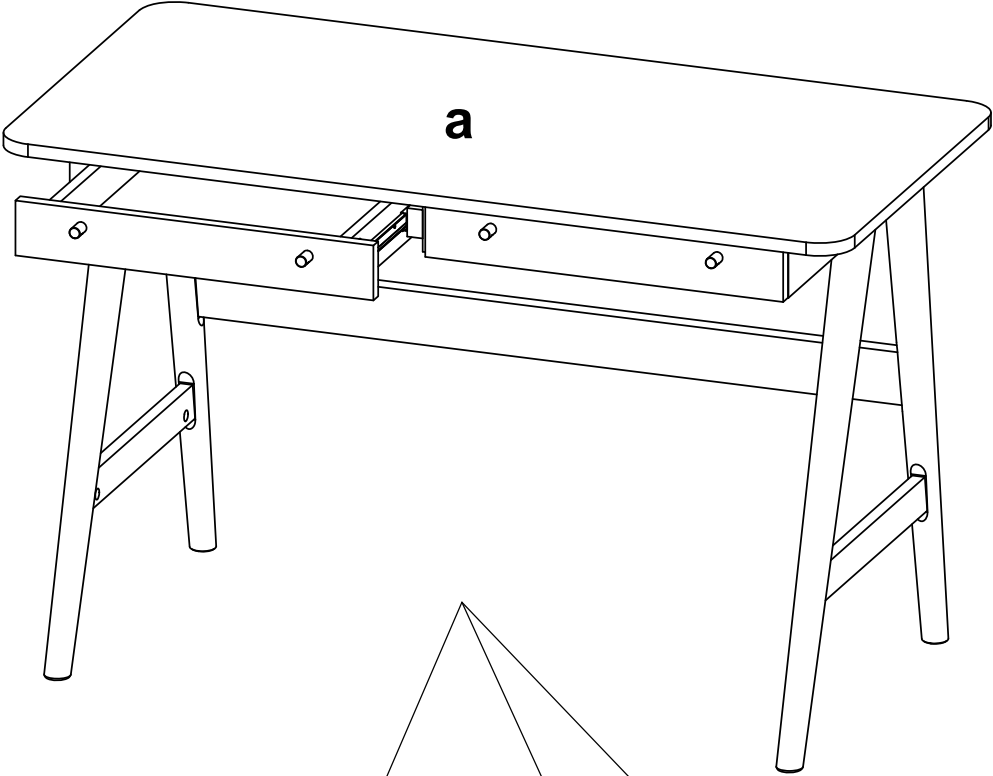

b

