

Montageanweisung / Installation instructions / Instruction de montage / Istruzioni di montaggio
montagehandleiding / Instrukcja montażu / Montaj talimatlar / Osszeszerelési útmutató / Návod k montáži /
Návod na montáž / Instrucțiune de montaj / Инструкция по монтажу / Montaj talimatina / Monteringsanvisningar
Upute za montažu / Instrucciones de Montaje / Navodila za montažo

Nivea/Soler

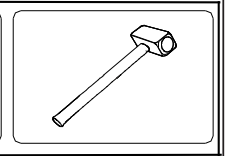
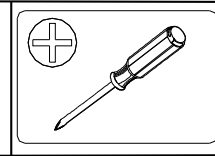

D Bitte lesen Sie diese Montageanleitung gut durch, da wir für Fehler, die durch falsche Montage entstehen, keine Haftung übernehmen!

GB Please read these installation instructions through carefully as we cannot accept any liability for faults occurring as a result of incorrect installation!

CZ Přečtěte si prosím pozorně tento návod k montáži, aby jste předešli chybám vzniklých špatnou montáží, za které neručíme!

F Veuillez lire attentivement cette notice de montage, car nous déclinons toute responsabilité en cas d'erreurs découlant d'un montage erroné !

I Prego leggere attentamente le istruzioni per il montaggio, poiché decliniamo qualsiasi responsabilità per difetti derivanti da un montaggio errato

S Läs monteringsanvisningarna noggrant. Vi avsåger oss allt ansvar för defekter som uppstår p.g.a. felaktig montering.

HR Pažljivo pročitajte upute za montažu, jer otklanjamo svaku odgovornost za pogreške nastale uslijed pogrešne montaže.

SLO Prosimo, da pozorno preberete navodila za montažo, saj zavračamo vsakršno odgovornost za napake, ki bi nastale zaradi napačne montaže.

NL Leest u alstublieft deze montagehandleiding goed door, voor fouten door verkeerde montage zijn wij niet verantwoordelijk.

PL Proszę uważnie zapoznać się z instrukcją montażu, ponieważ nie ponosimy odpowiedzialności za niewłaściwy montaż.

HU Kérjük, olvassa el figyelmesen ezt az összeszerelési útmutatót, mert a helytelen összeszerelésből a dódó hibáért nem vállalunk felelősséget!

SK Prosíme, dobre prečítajte si tento návod na montáž, pretože nepreberáme žiadne ručenie za chyby, ktoré vzniknú na základe chybnej montáže!

RO Vă rugăm să citiți cu atenție aceste instrucțiuni de montaj deoarece nu preluăm garanția pentru defecte ce apar datorită unui montaj incorect!

RUS Пожалуйста, внимательно ознакомьтесь с данной инструкцией по монтажу, поскольку мы не несем ответственности за ошибки, причиной которых является неправильный монтаж.

TU İlk önce kullanma klavuzunu iyi okuyun, yalnız montaj yapmanız bunun sorumlusu biz değildir.

E Se ruega leer con atención las instrucciones de montaje debido a que declinamos cualquier responsabilidad por defectos derivados de un montaje erróneo

LC S.p.A
Via del Piano s.n
61030 Isola del Piano (PU)
Italia

Total Kollis 2 Stuecke
Total colli 2 pieces
Numero total des colis:2
Colli totali 2
Totaal 2 colli's
Razem sztuk 2
Toplam parçalar 2
Celkem baličky 2
Teljes csomag 2
Celkom baličky 2
количество Всего 2
Total colete 2
Totalt antal kollin 2
Ukupno koleta 2
Bultos Totales 2
Skupno število paketov 2

SERVICEKARTE

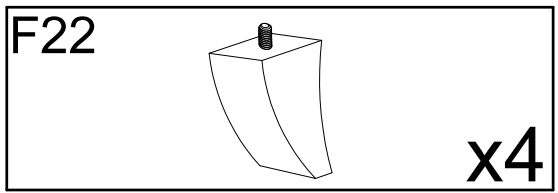
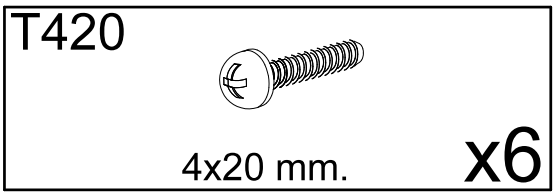
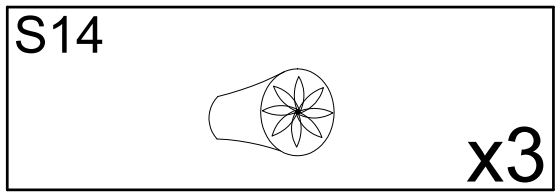
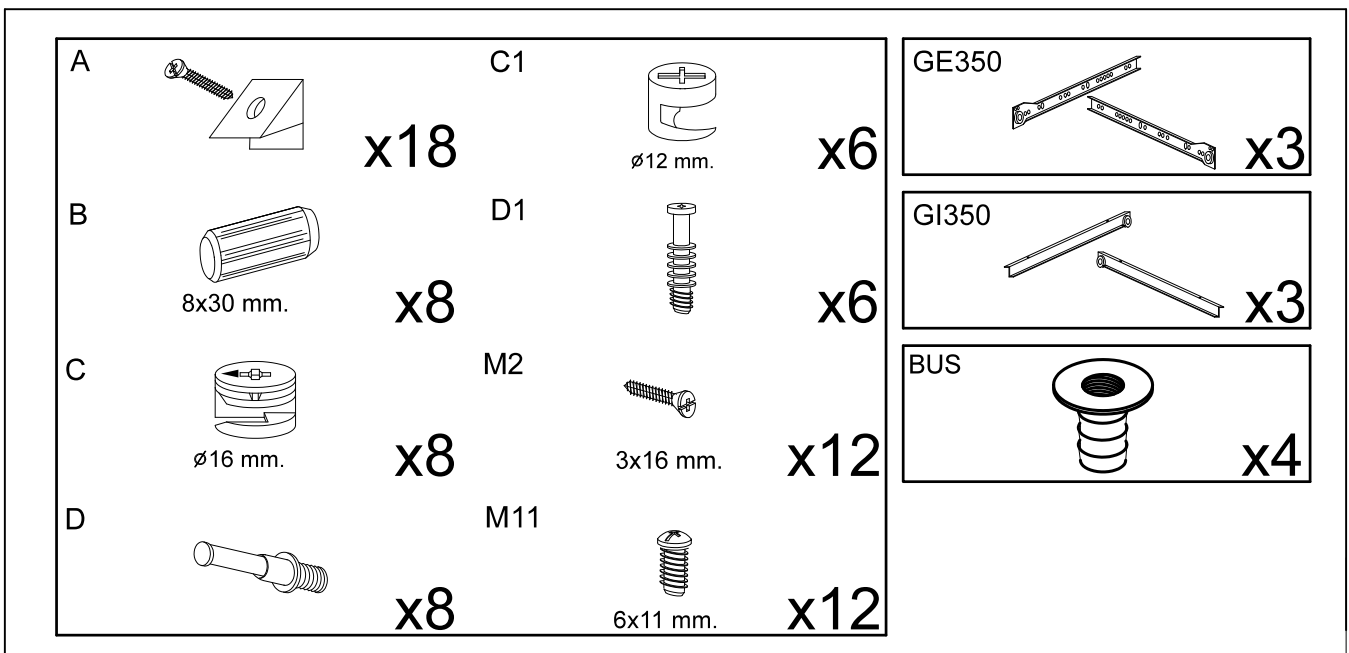
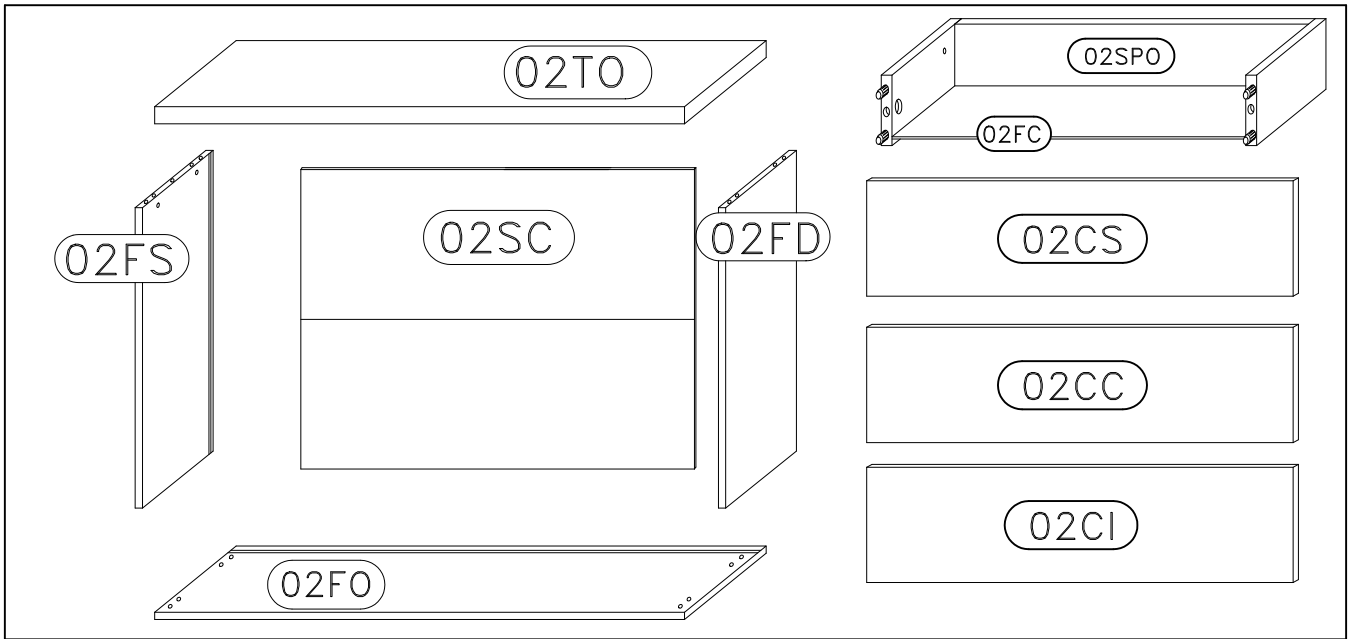

- Von Innen die Tueren an der vorgebohrten Loechern wie gezeigt vorsichtig durchbohren. Um Ausrisse zu vermeiden, beim Bohren ein Stueck Holz dagegenhalten.
- Perçer soigneusement les trous préforés comme indiqué. Pour éviter des fentes, appuyer une pièce de bois au lieu du perçage.
- Bore carefully the pre-drilled holes, as showed here below. To avoid rips, lay a piece of wood on the opposite side of the piece behind the hole.
- Ponendo molta attenzione, sfondare i fori già preforati, come mostrato qui. Per evitare spaccature, appoggiare un pezzo di legno dietro il foro.

1

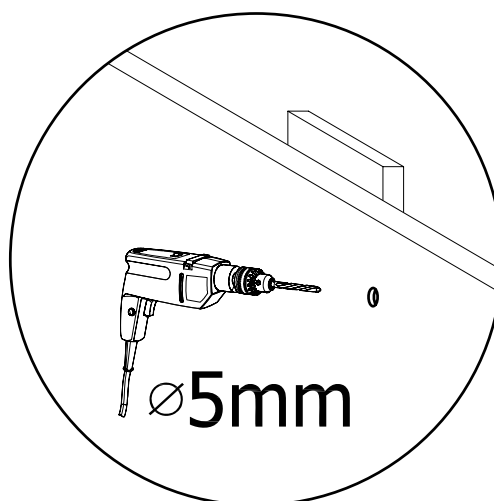
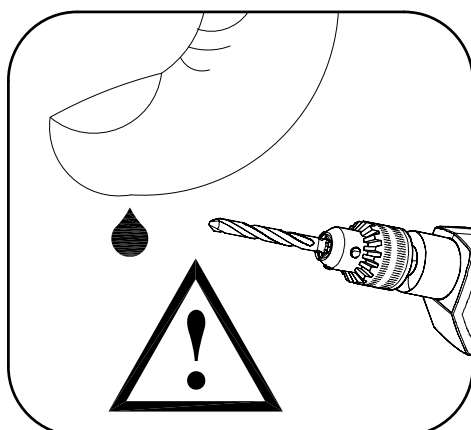
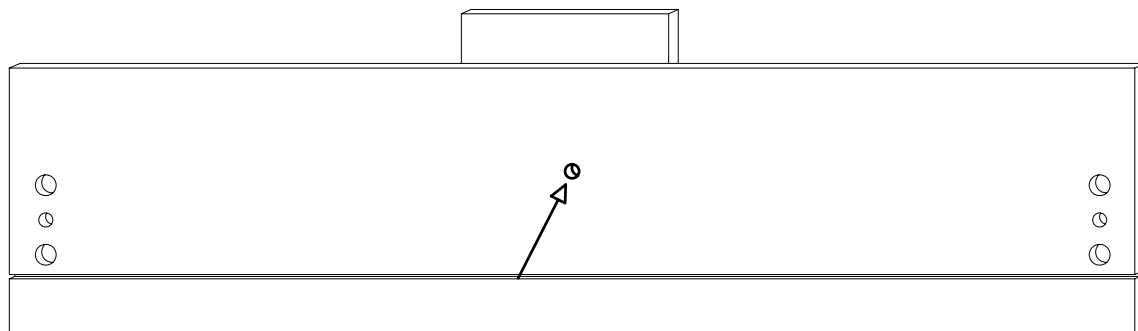

2

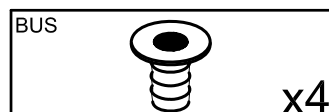

3

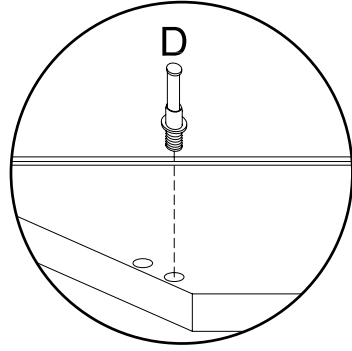

B		8x30 mm.	x8	GE350		x3
C		ø16 mm.	x8	M11		x12
D			x8			

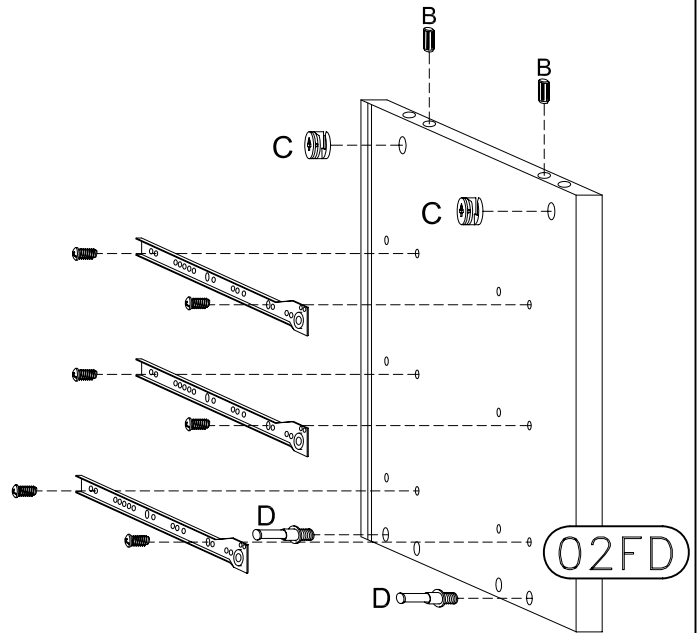
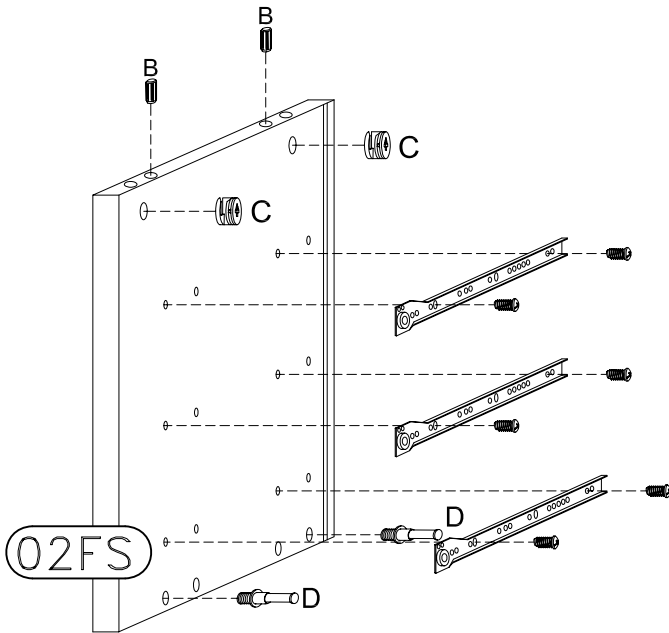

GE350

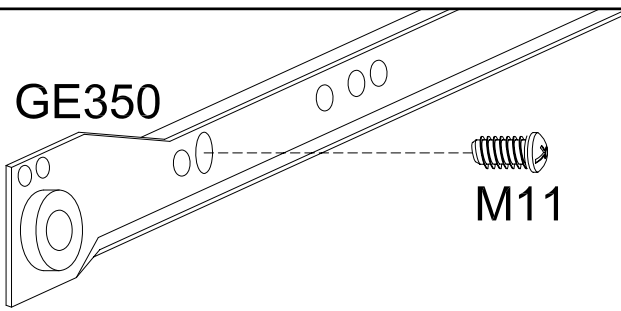

M11

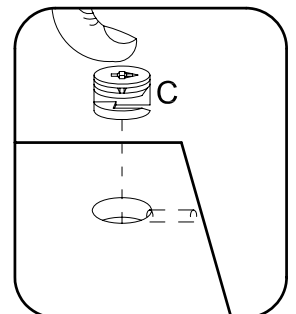

4

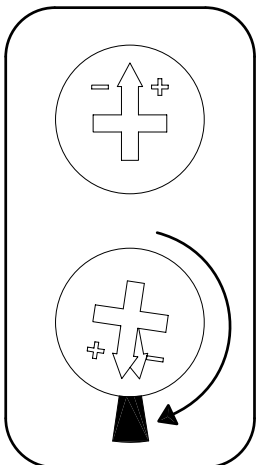
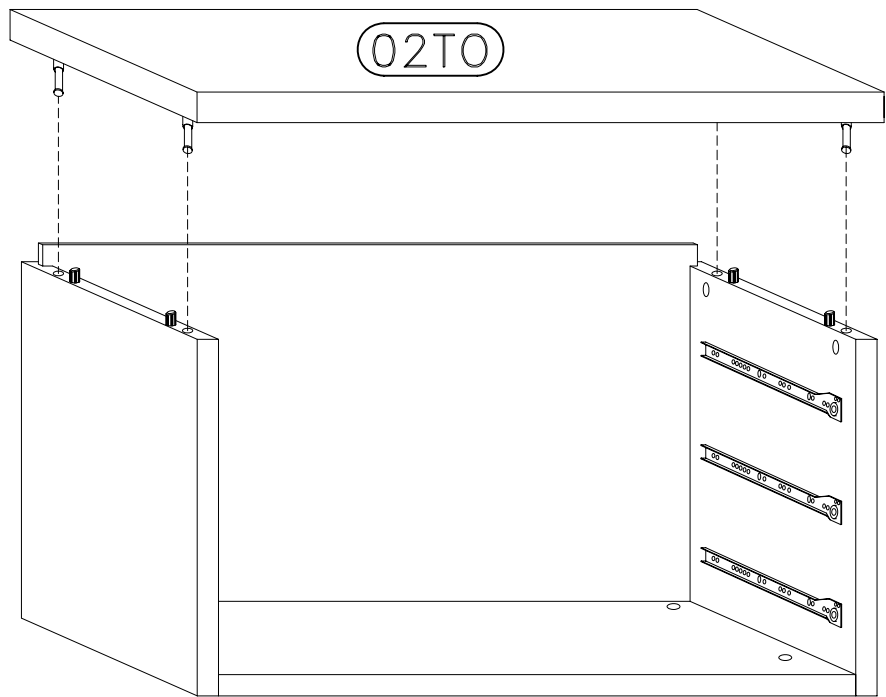
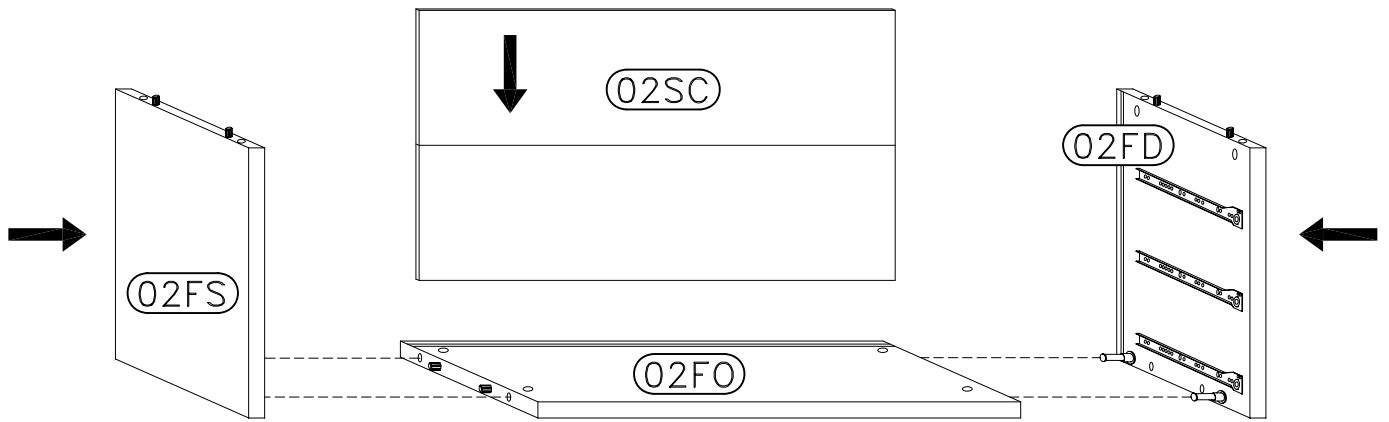

5

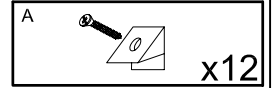
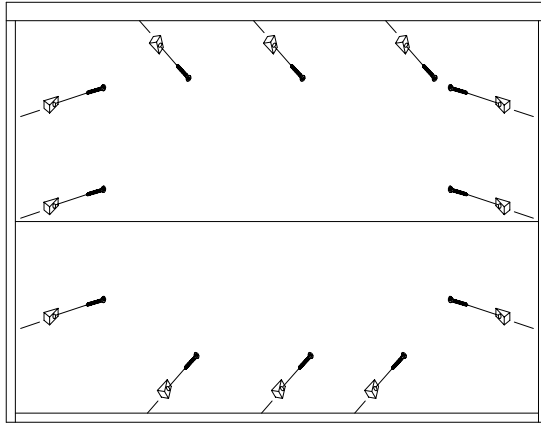
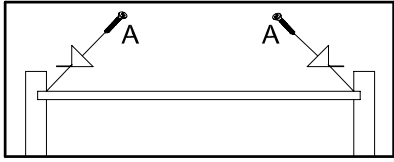

6

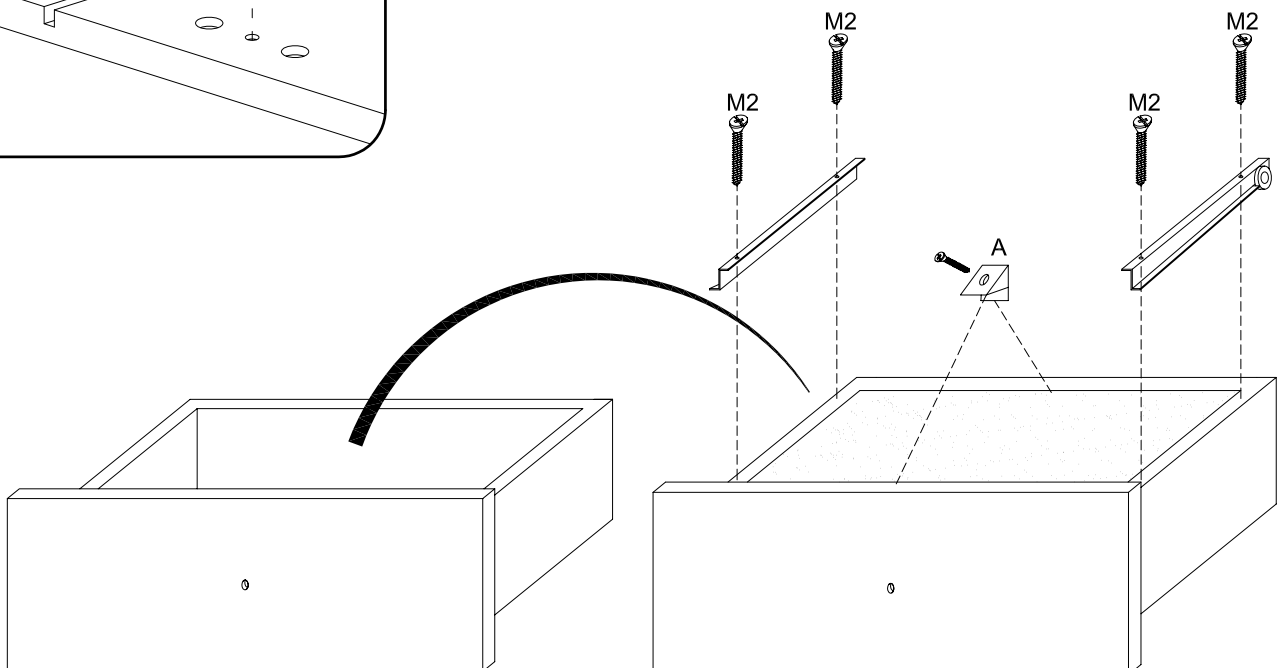
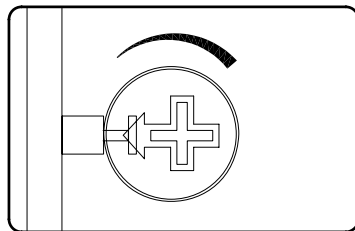
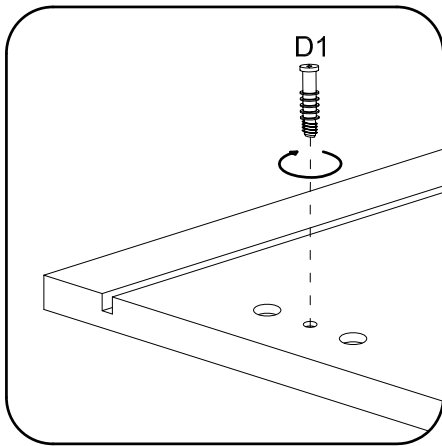
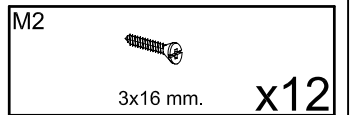
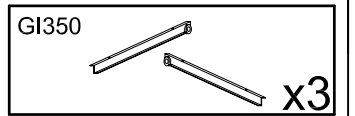
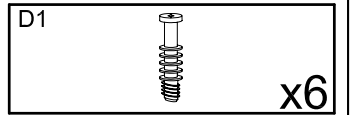
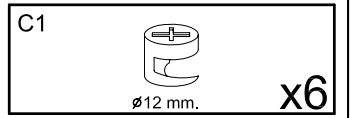
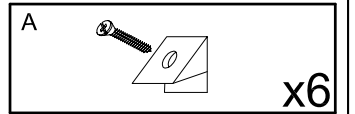
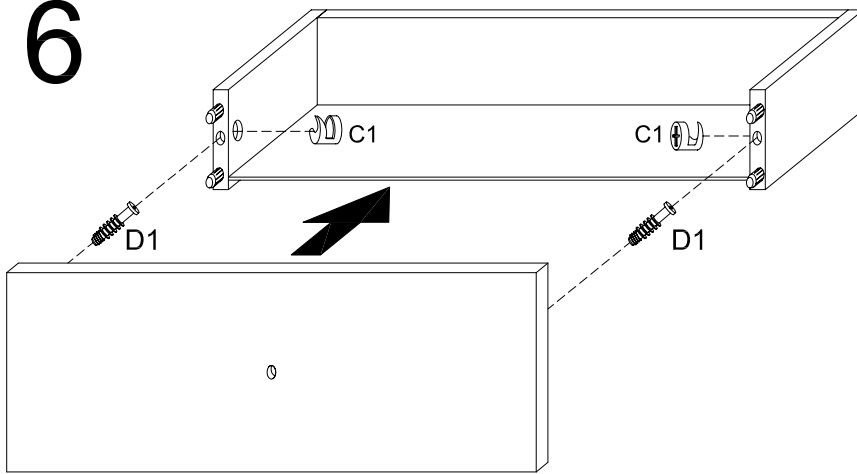

7

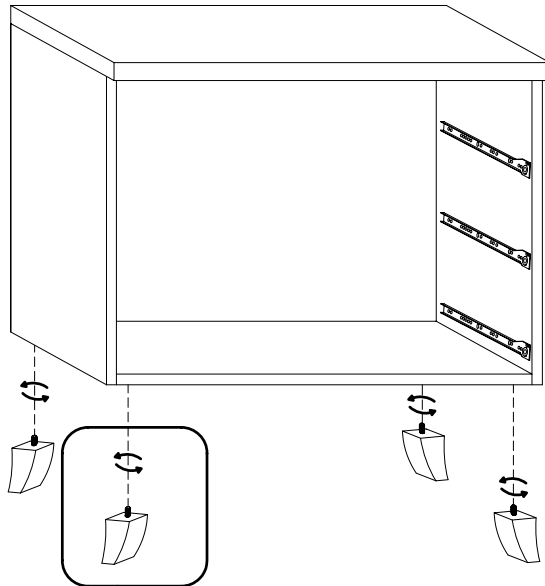

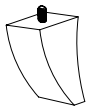

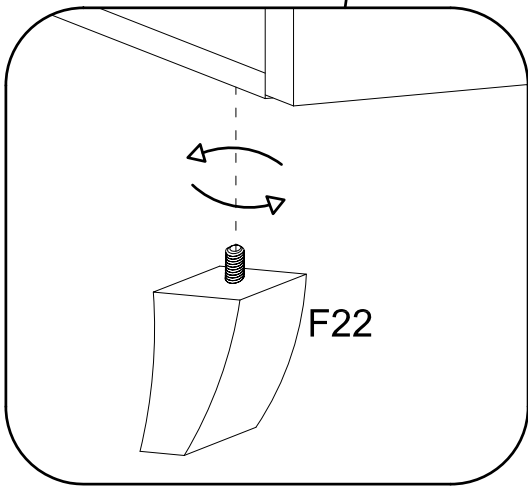
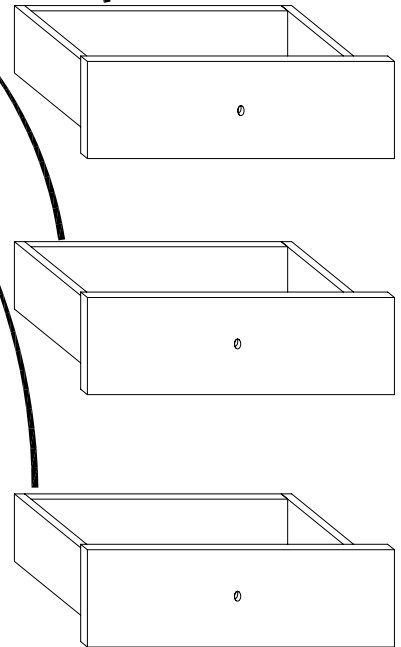
F22  x4

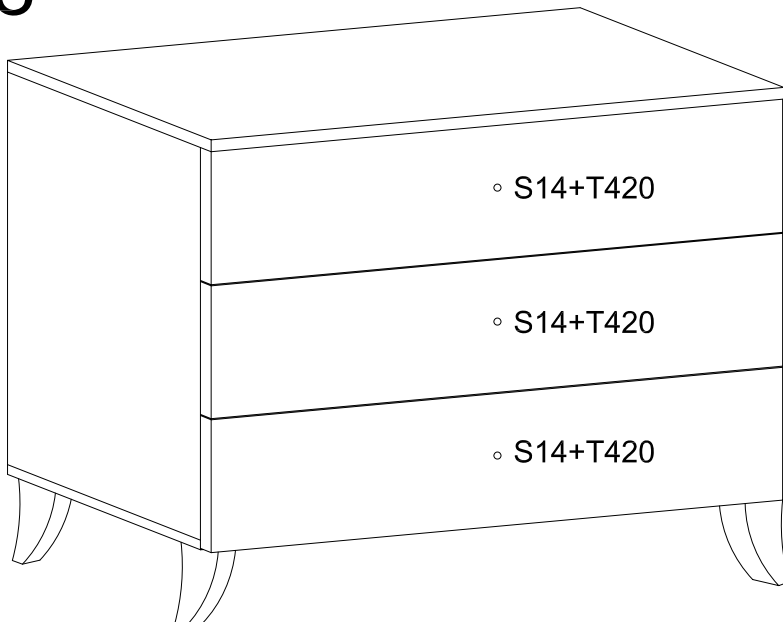

8



T420  x3
4x20 mm.

S14  x3

