

- | | |
|---|---|
| (D) Montageanleitung 1372 | (GB) Assembly instructions 1372 |
| (FR) Notice de montage 1372 | (IT) Istruzioni di montaggio 1372 |
| (NL) Handleiding voor de montage 1372 | (PL) Instrukcja montażu 1372 |
| (CZ) Montážní návod 1372 | (SK) Návod na montáž 1372 |
| (HU) Szerelési útmutató 1372 | (RO) Instrucțiuni de montaj 1372 |
| (TR) Montaj talimatı 1372 | (RU) Инструкция по монтажу 1372 |

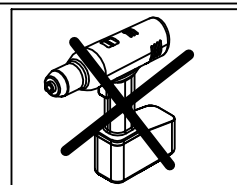
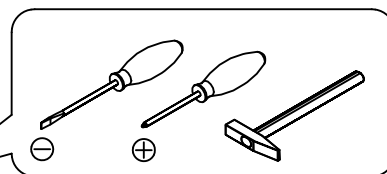
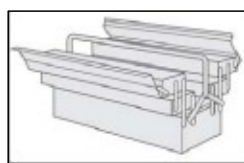
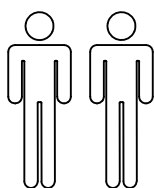

Name • Nom • Nome • Naam • Nazwa • Jméno •
Názov • Név • Denumire • Isim • Название

Nr. • No. • № • Номер • Č. • Sz

Typ • Type • Tip • Típus • Tun

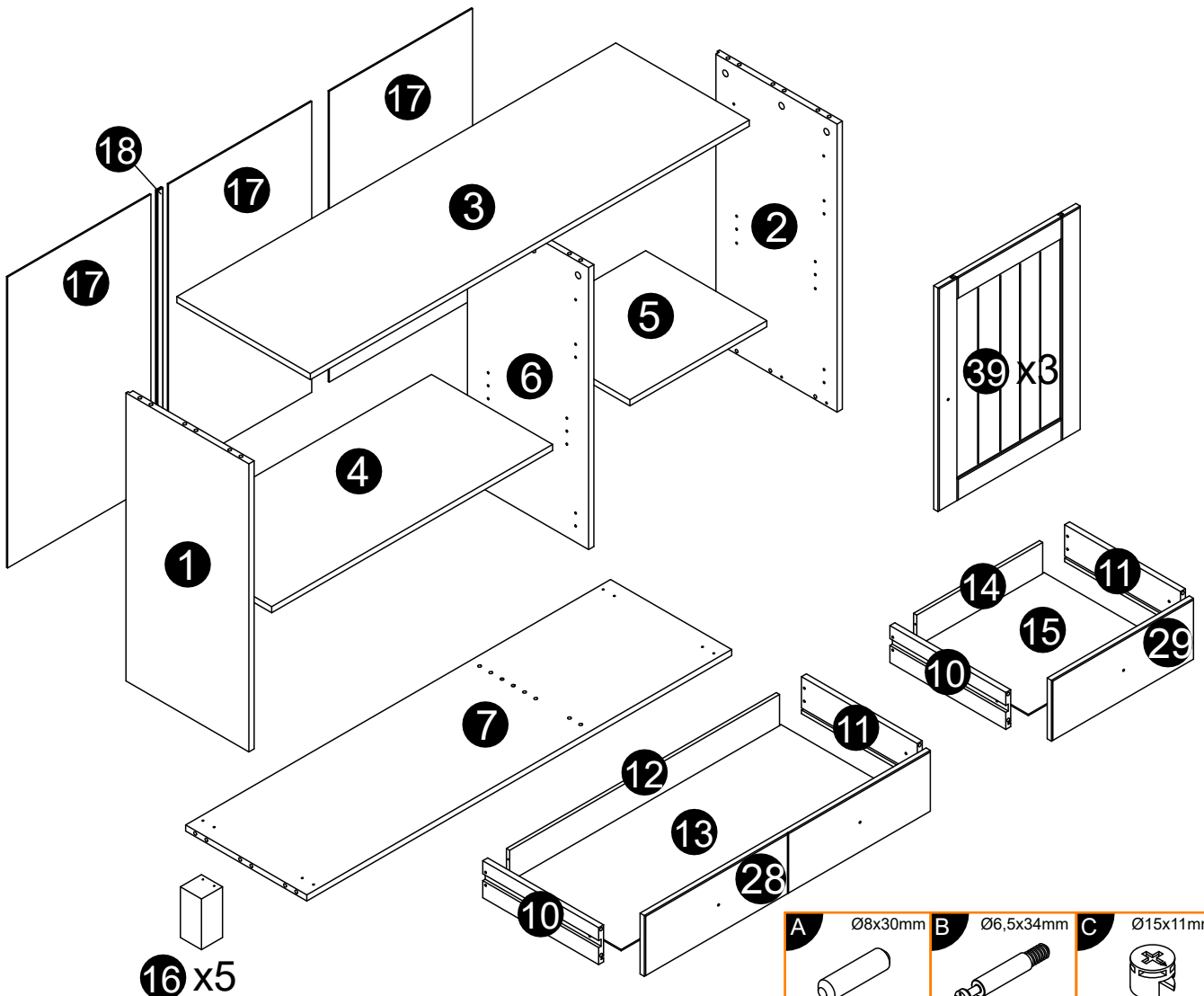
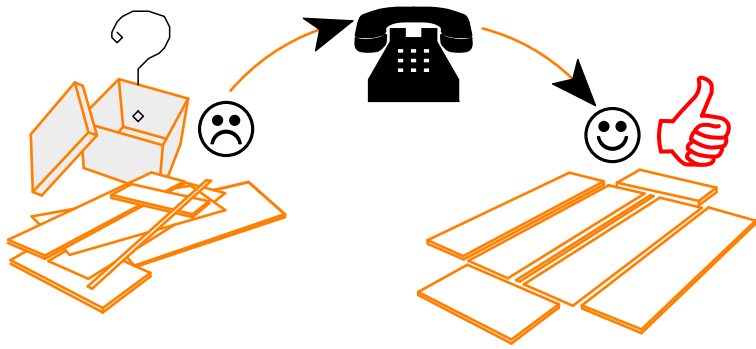
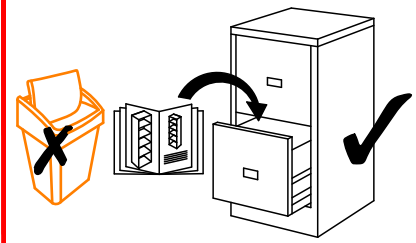

| | | | | | | | | |
|---------------------------|---------------------------|---------------------------|----------------|--|--------------------------|-------------------------|-----------------------|------------------------|
| D Ø3,5x15mm 13x | E 6x | G Ø1,2x20mm 50x | H 1x | I 20x16mm Ø4,5mm 1x | J Ø4x60mm 1x | K Ø5x16mm 8x | L 6x | M Ø4x20mm 6x |
| N Ø26x3mm 5x | O Ø3,5x35mm 18x | P Ø7x50mm 3x | R 1x | U 1x D Leim GB Glue FR Colle IT Colla NL Lijm | Aa Ø5,8x9mm 8x | Ac M4x10mm 4x | Ad 310mm 4x | Ae Ø26mm 6x |
| A Ø8x30mm 26x | B Ø6,5x34mm 15x | C Ø15x11mm 15x | | | | | | |

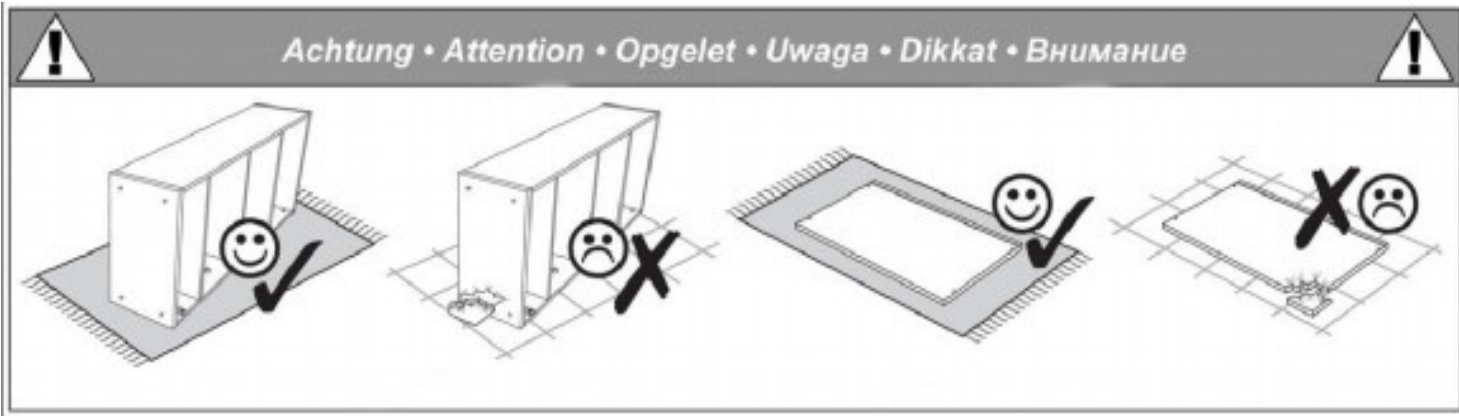

- 1**
- | | | |
|---------------------------|-----------------------------|----------------|
| A Ø8x30mm 8x | O Ø3,5x35mm 8x | U 1x |
|---------------------------|-----------------------------|----------------|
- PL Klej
 CZ Lepidlo
 SK Glej
 HU Ehyv
 RO Adeziv
 TR Tutkal
 RU Клей
- D Leim
 GB Glue
 FR Colle
 IT Colla
 NL Lijm

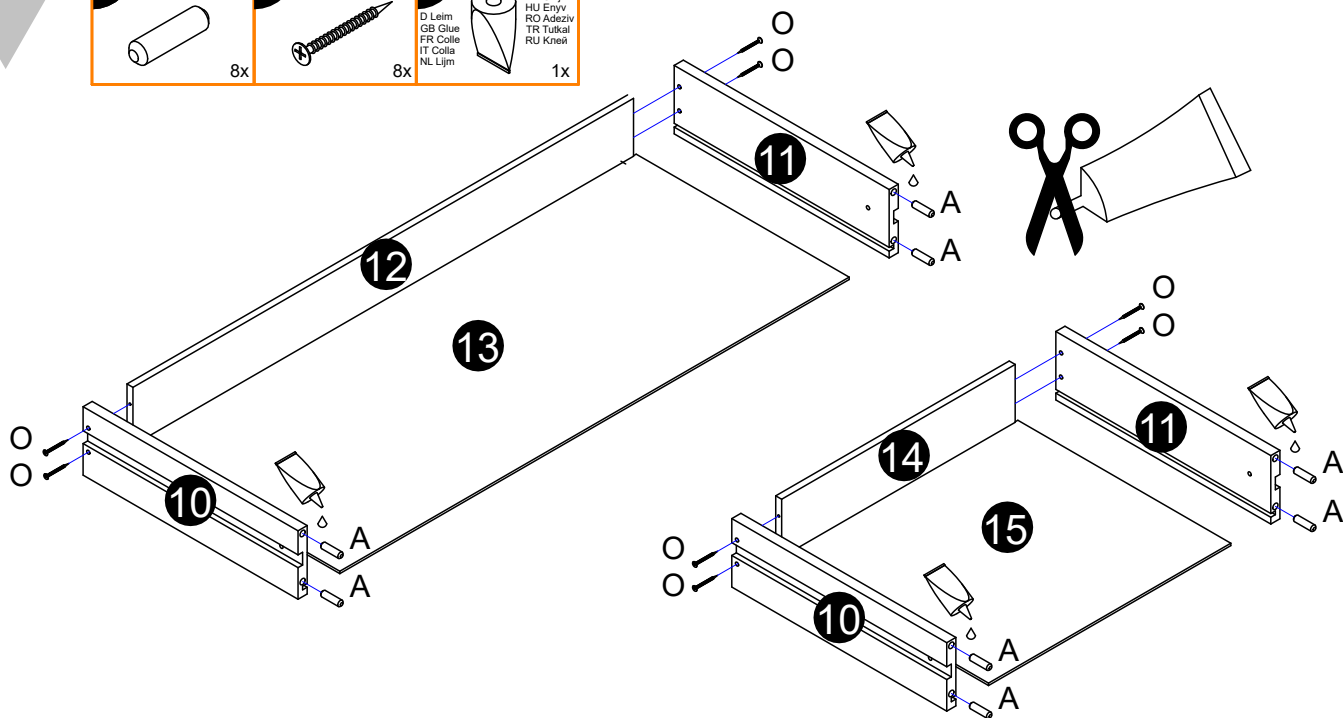

- 2**
- | | |
|----------------|---------------------------|
| L 3x | M Ø4x19mm 3x |
|----------------|---------------------------|

- U**
1x
- PL Klej
 CZ Lepidlo
 SK Glej
 HU Ehyv
 RO Adeziv
 TR Tutkal
 RU Клей
- D Leim
 GB Glue
 FR Colle
 IT Colla
 NL Lijm

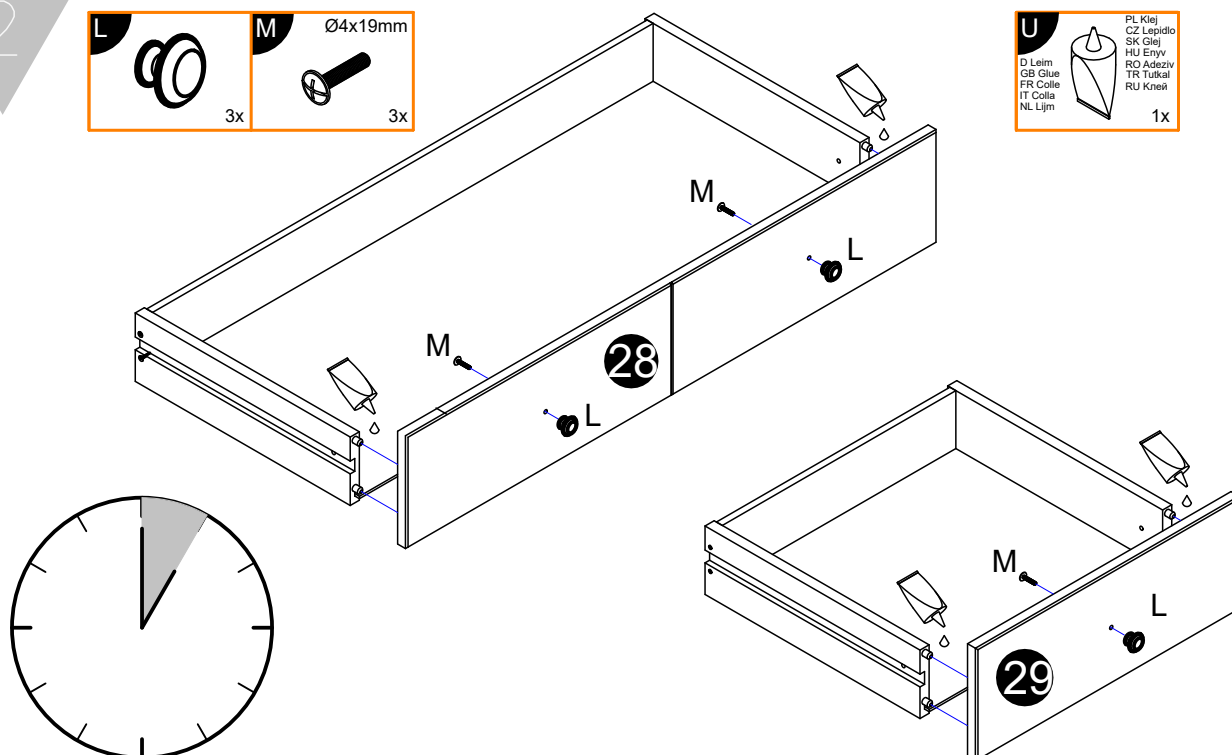

3

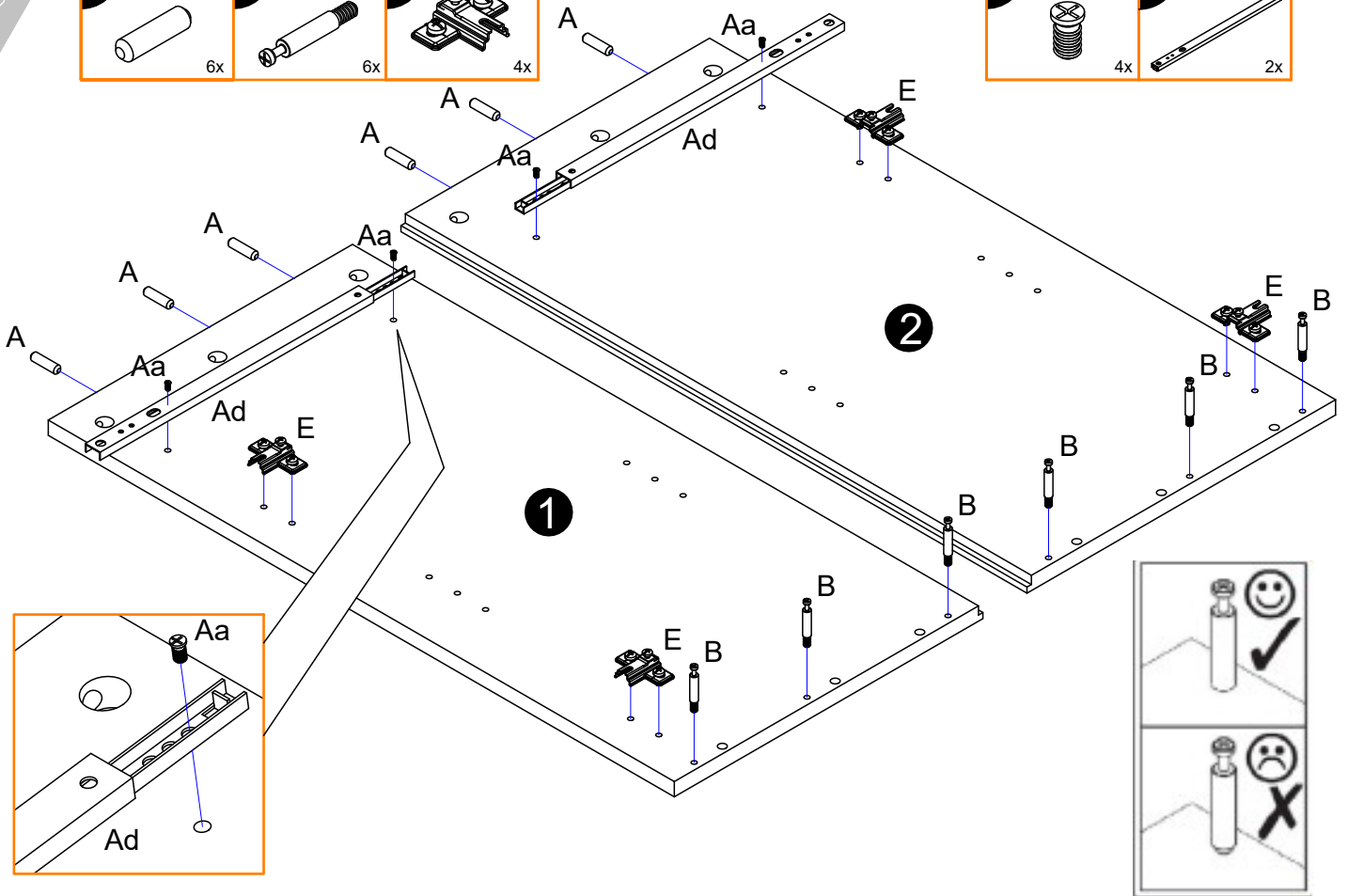
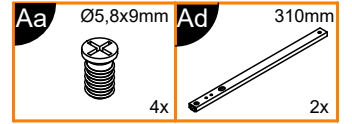
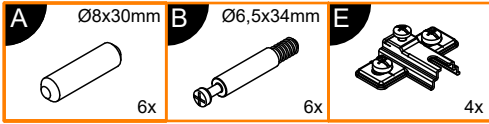

4

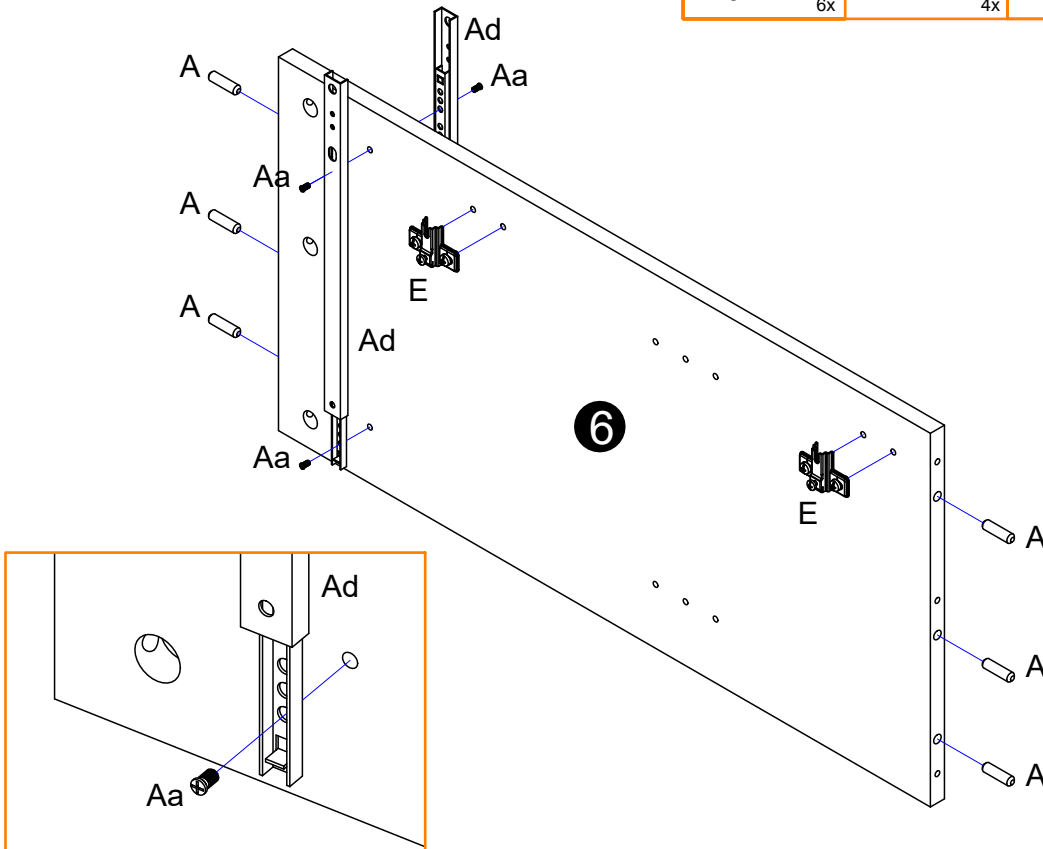
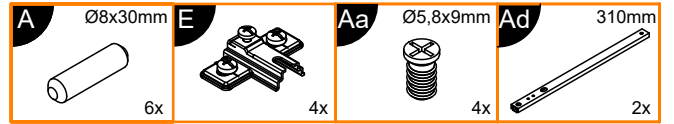

5

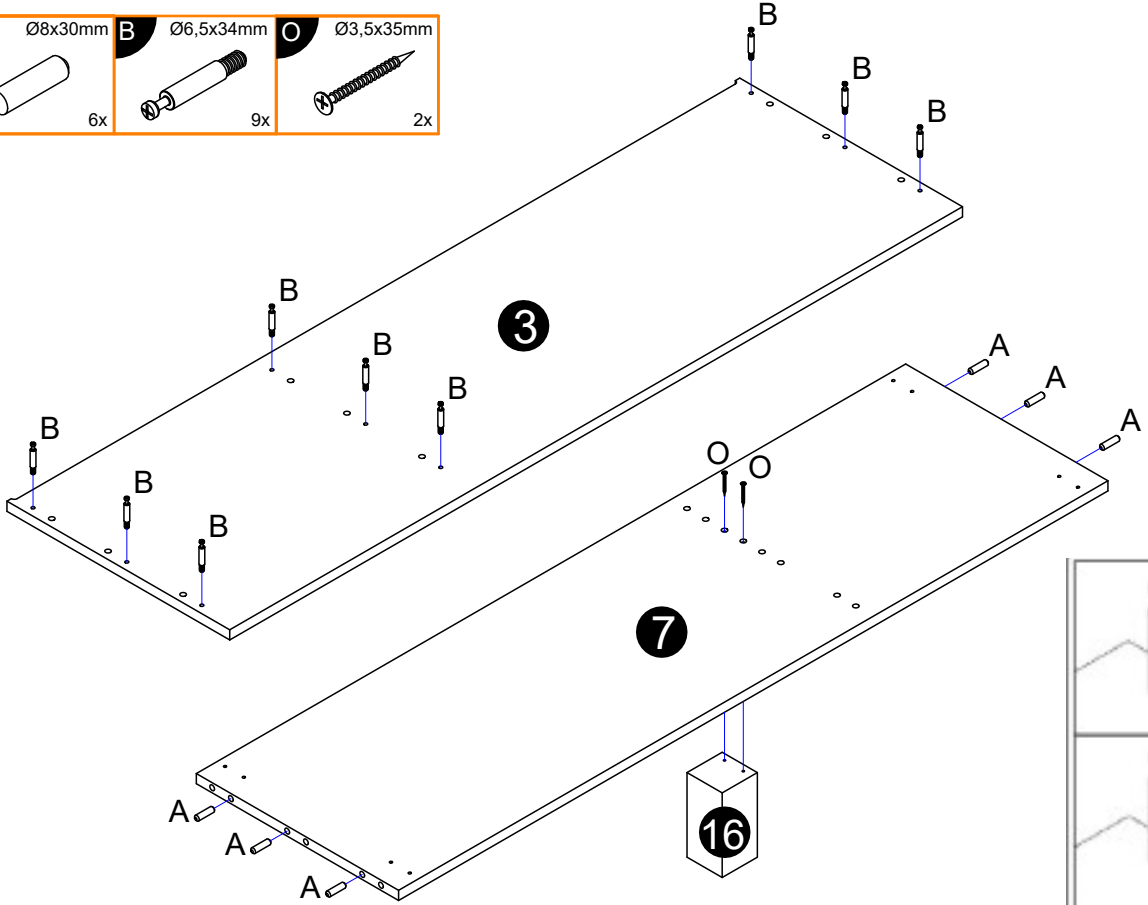
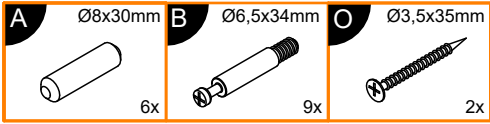

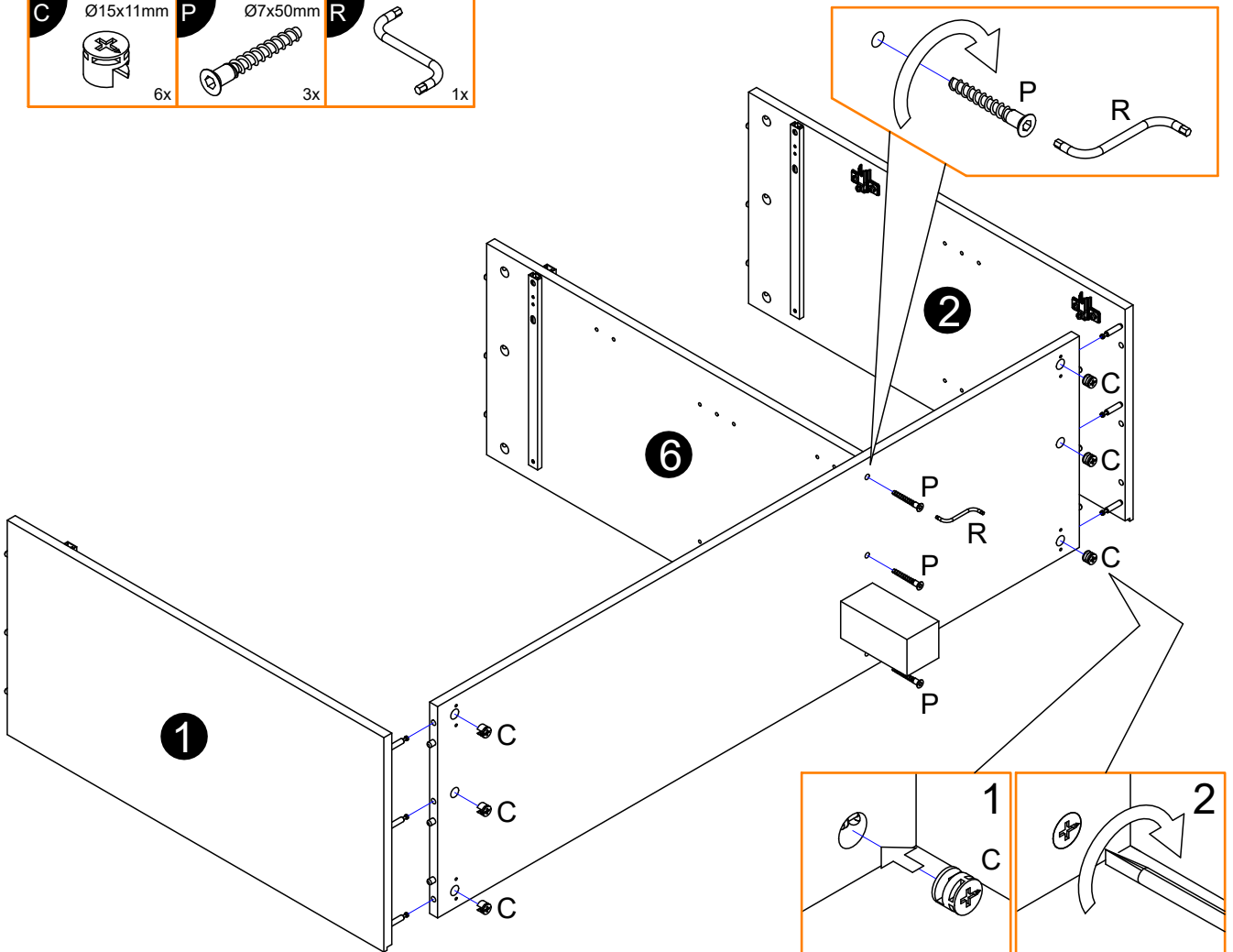
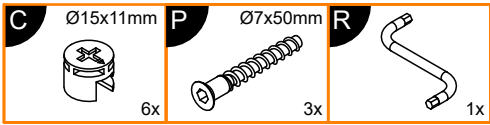

6

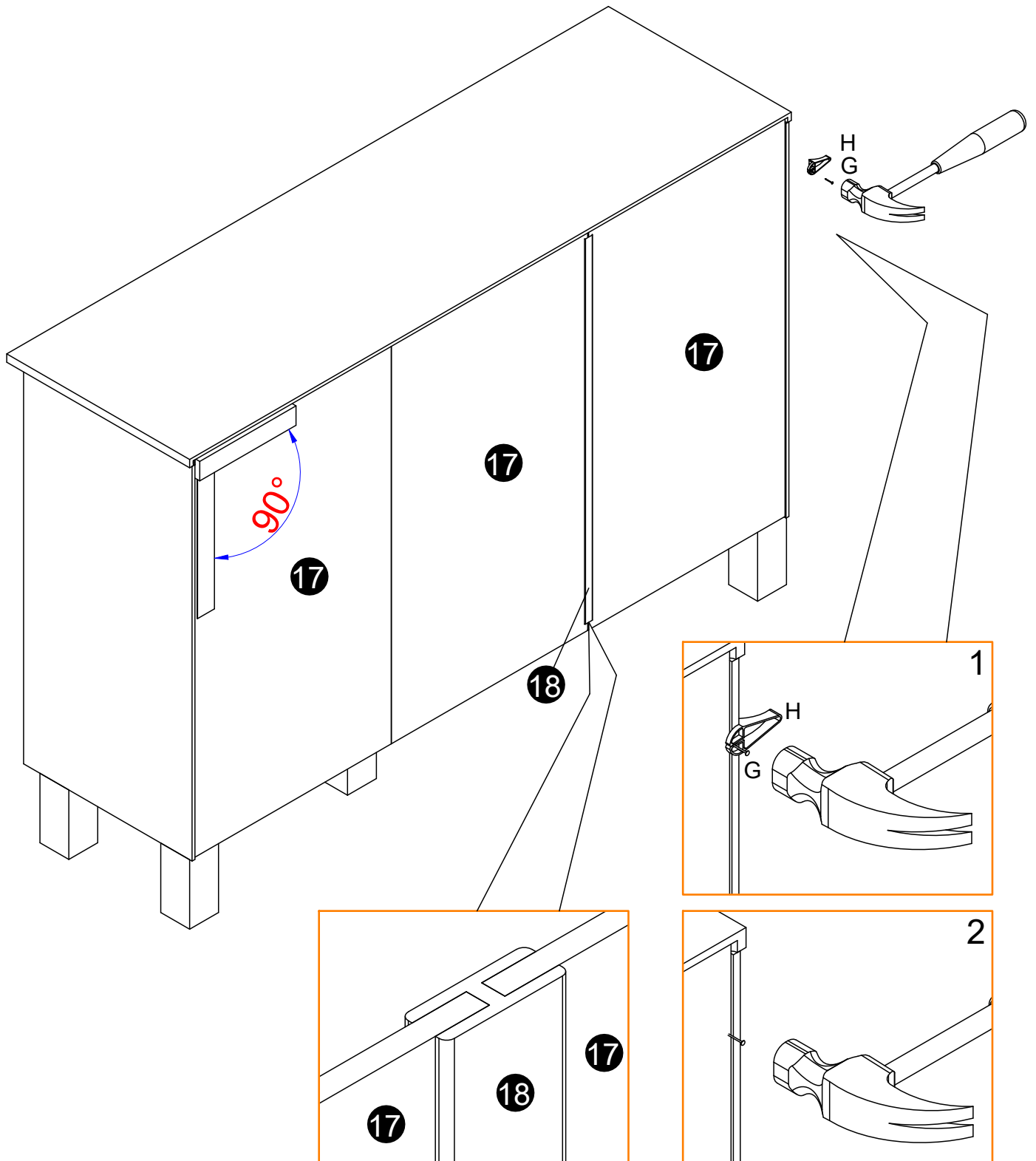
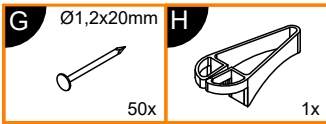

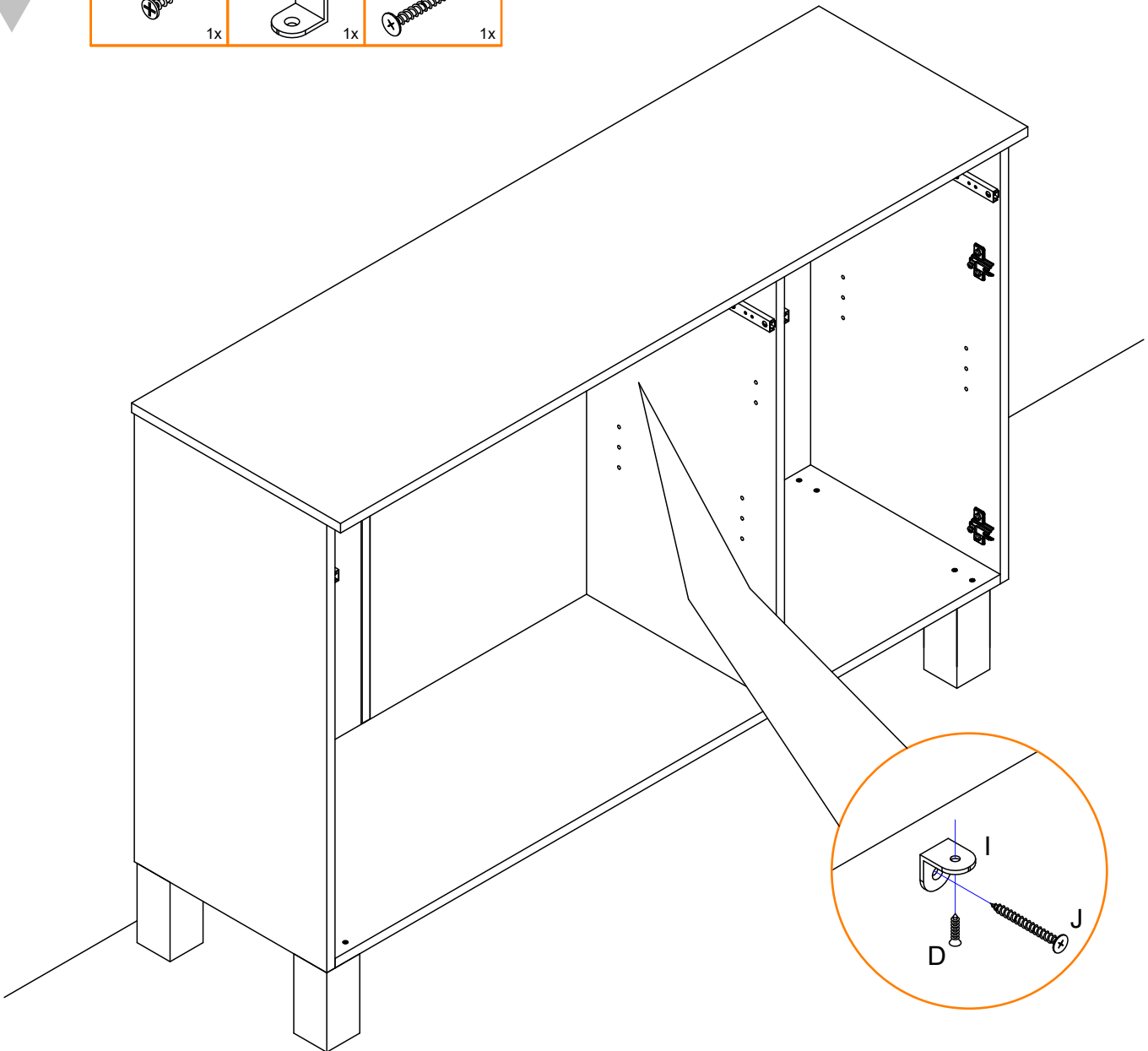
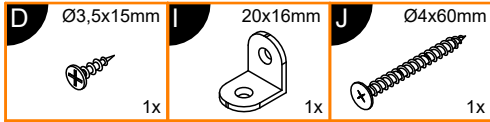



|  Achtung • Attention • Attenzione • Opgelet • Uwaga • Pozor • Figyelem • Aten ție • Dikkat • Внимание  | |
|---|--|
| (D) | Wandbefestigung dient als Kippschutz - unbedingt anbringen! Bei einigen Wandtypen kann ein Spezialdübel erforderlich sein! |
| (GB) | The wall fastening serves to prevent tipping - be absolutely sure to mount it! For certain wall types, a special dowel may be necessary! |
| (NL) | Bevestiging aan de muur dient als kantelbescherming - zeker en vast bevestigen! Bij enkele muurtypes is een speciale plug misschien vereist! |
| (PL) | Mocowanie do ściany jest jednocześnie zabezpieczeniem przed przewróceniem - koniecznie zamontować! Do niektórych rodzajów ścian konieczne mogą być specjalne wkręty! |
| (TR) | Duvardaki sabitleme, devrilmeye kar ışı bir emniyet tedbiridir ve mutlaka monte edilmelidir! Baz ı duvar tiplerindebunun ı çin özel bir dübel gerekli olabilir! |
| (RU) | Обязательно установите крепление на стене во избежание опрокидывания! Для некоторых типов стен может потребоваться специальный дюбель! |
| (FR) | La fixation murale sert de protection contre le basculement — à installer impérativement ! Pour certains types de murs il faut des chevilles spéciales! |
| (IT) | Il fissaggio alla parete serve da protezione anti-ribaltamento - attaccarla assolutamente! Per alcune strutture di parete pu ò essere necessario un tassello speciale! |
| (CZ) | Montáž na stěnu slouží jako ochrana proti převrnutí - bezpodmínečně umístěte! U některých typů stěn může být zapotřebí speciální hmoždinka! |
| (SK) | Upevnenie na stenu slúži ako ochrana proti prevráteniu - bezpodmienečne použite! Pre niektoré druhy stien m ôže byť potrebná špeciálna hmoždinka! |
| (HU) | A terméket a falhoz kel rögzíténi, különben az felborulhat! Egyes falt ípusoknál speciális tiplit kell használni! |
| (RO) | Sistemul de fixare la perete serve ște ca protecție la răsturnarede montat obligatoriu! Pentru unele tipuri de pere ți este posibil să fie necesar un diblu special! |

11

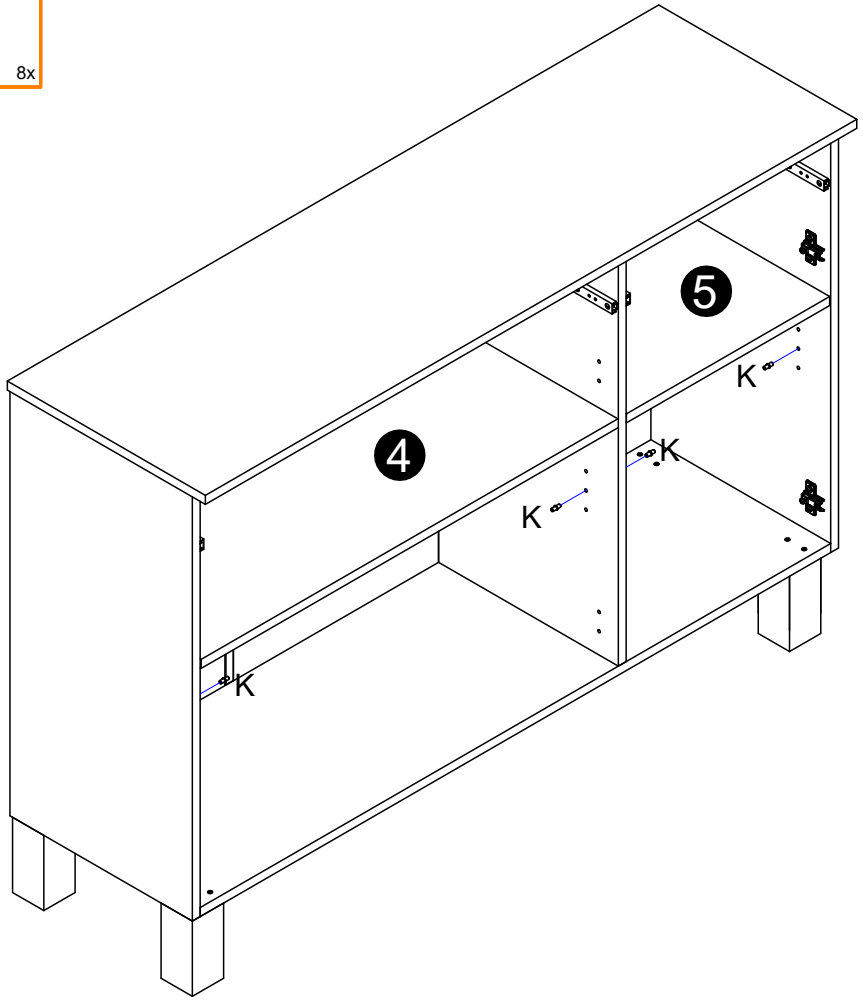
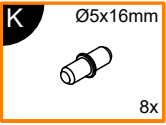

12

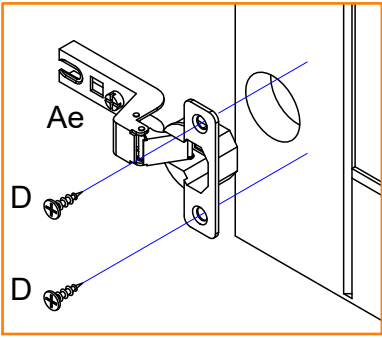
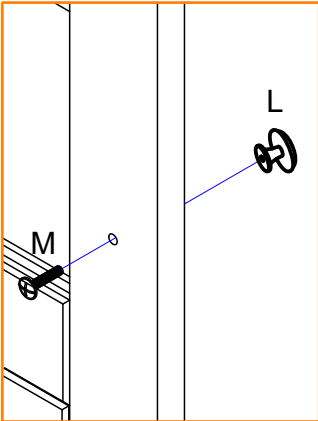
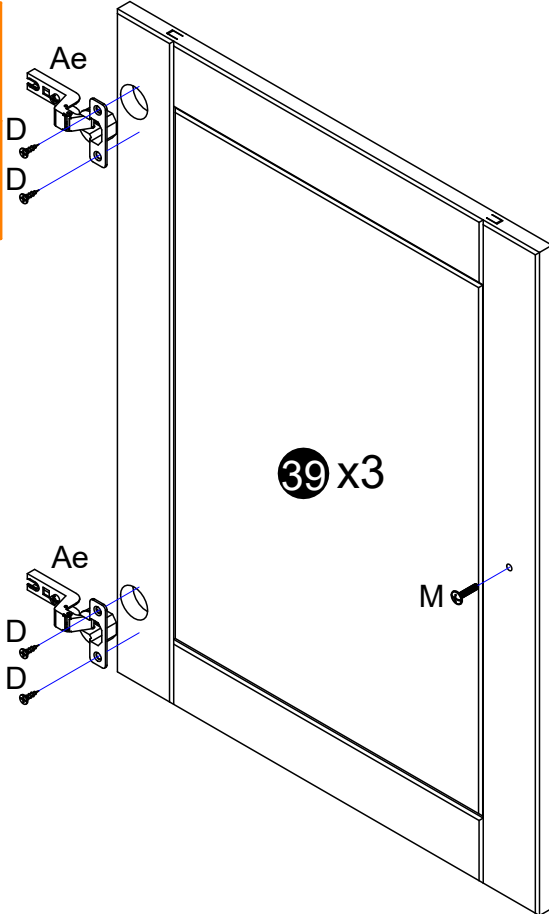
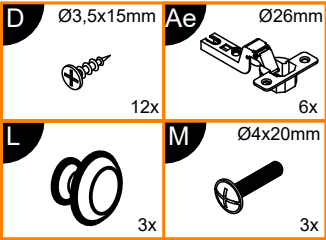

13

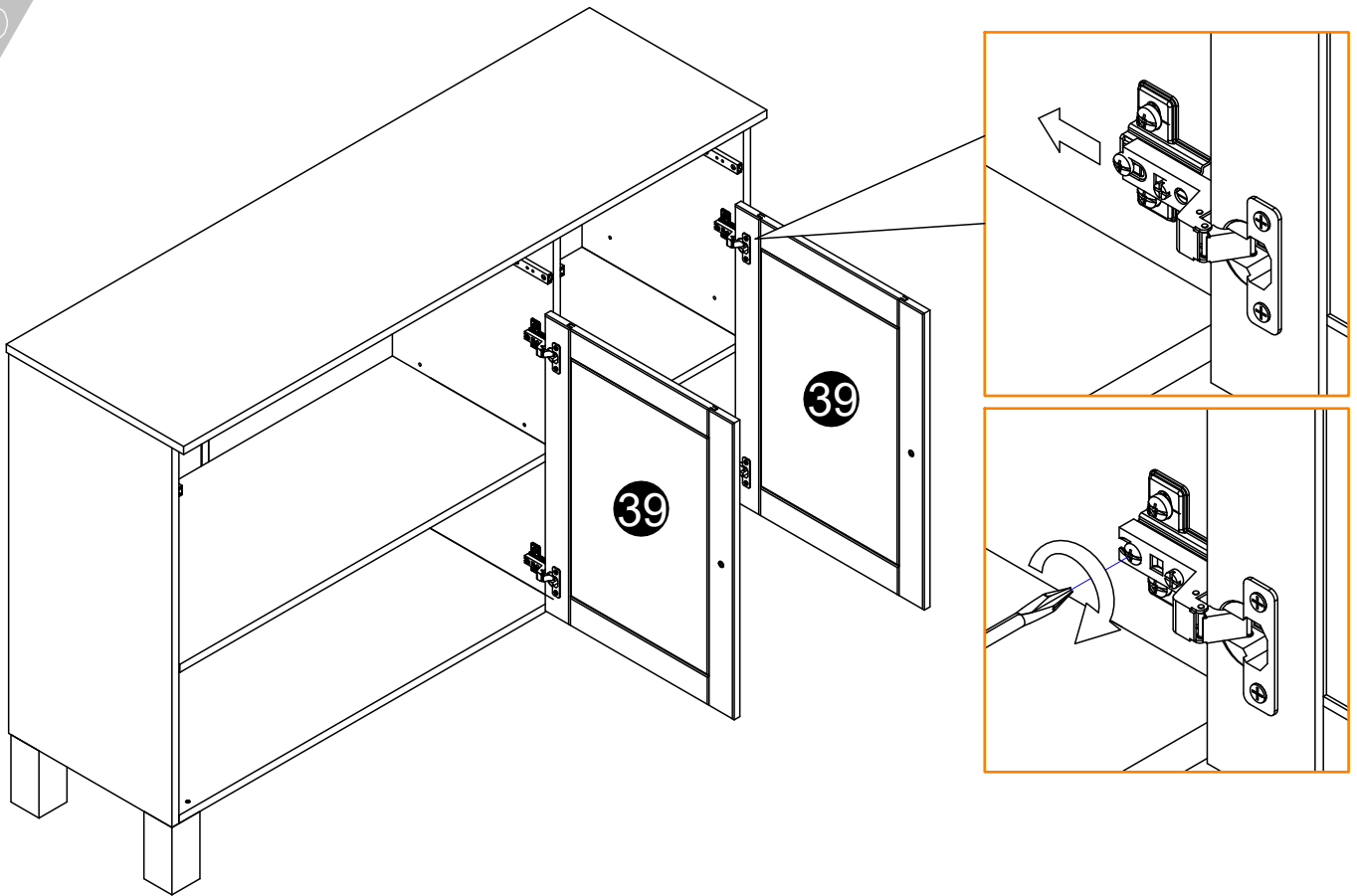

14

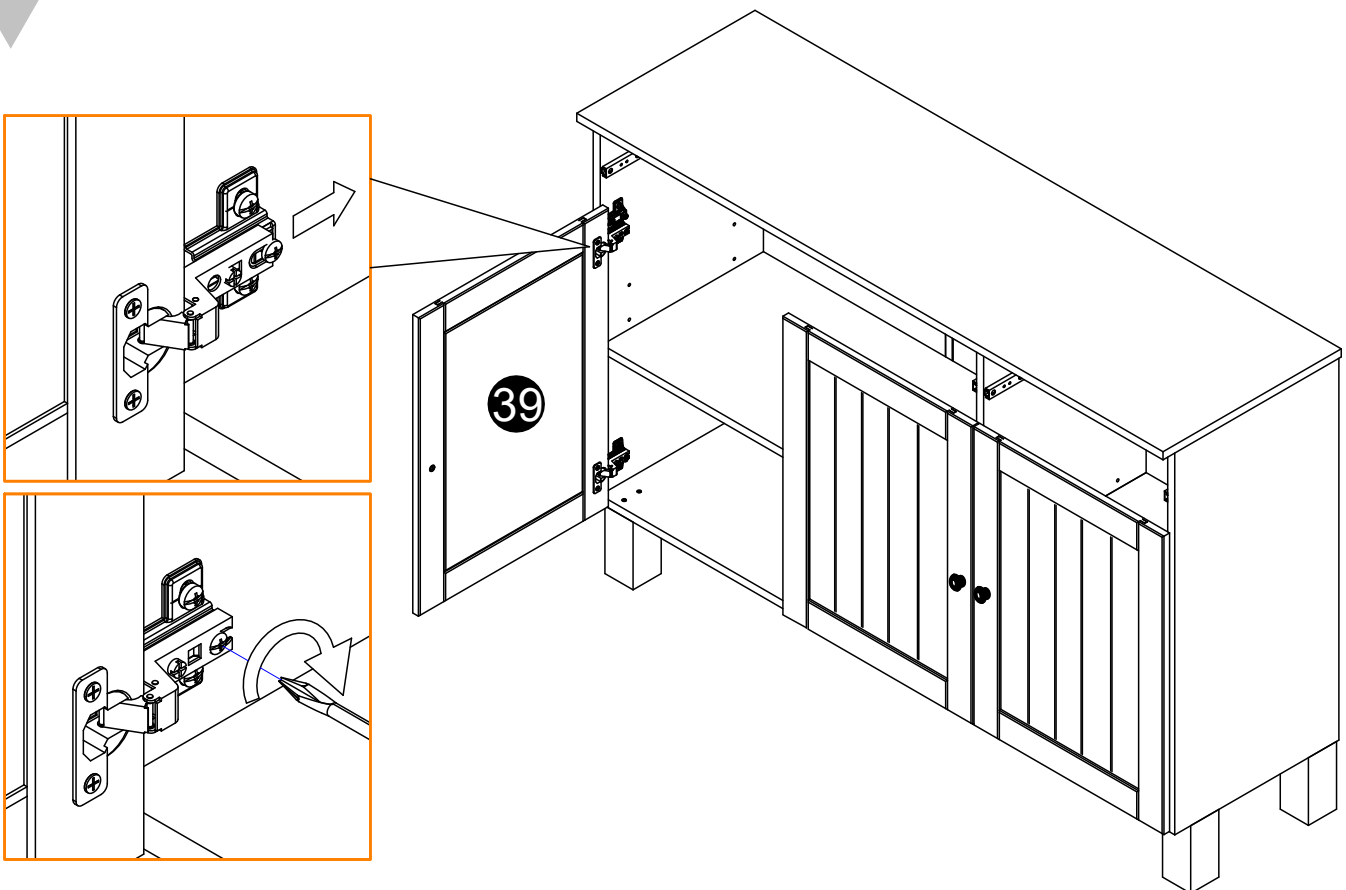

15

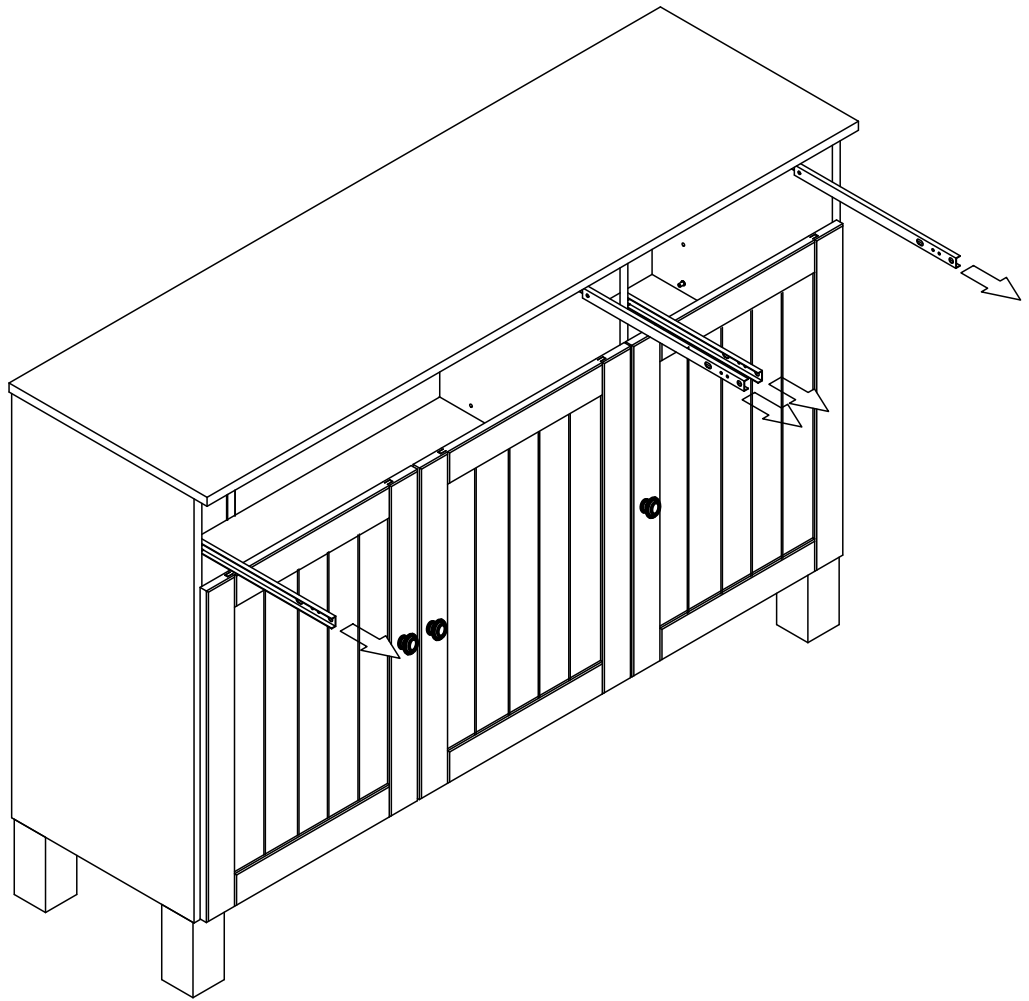

16

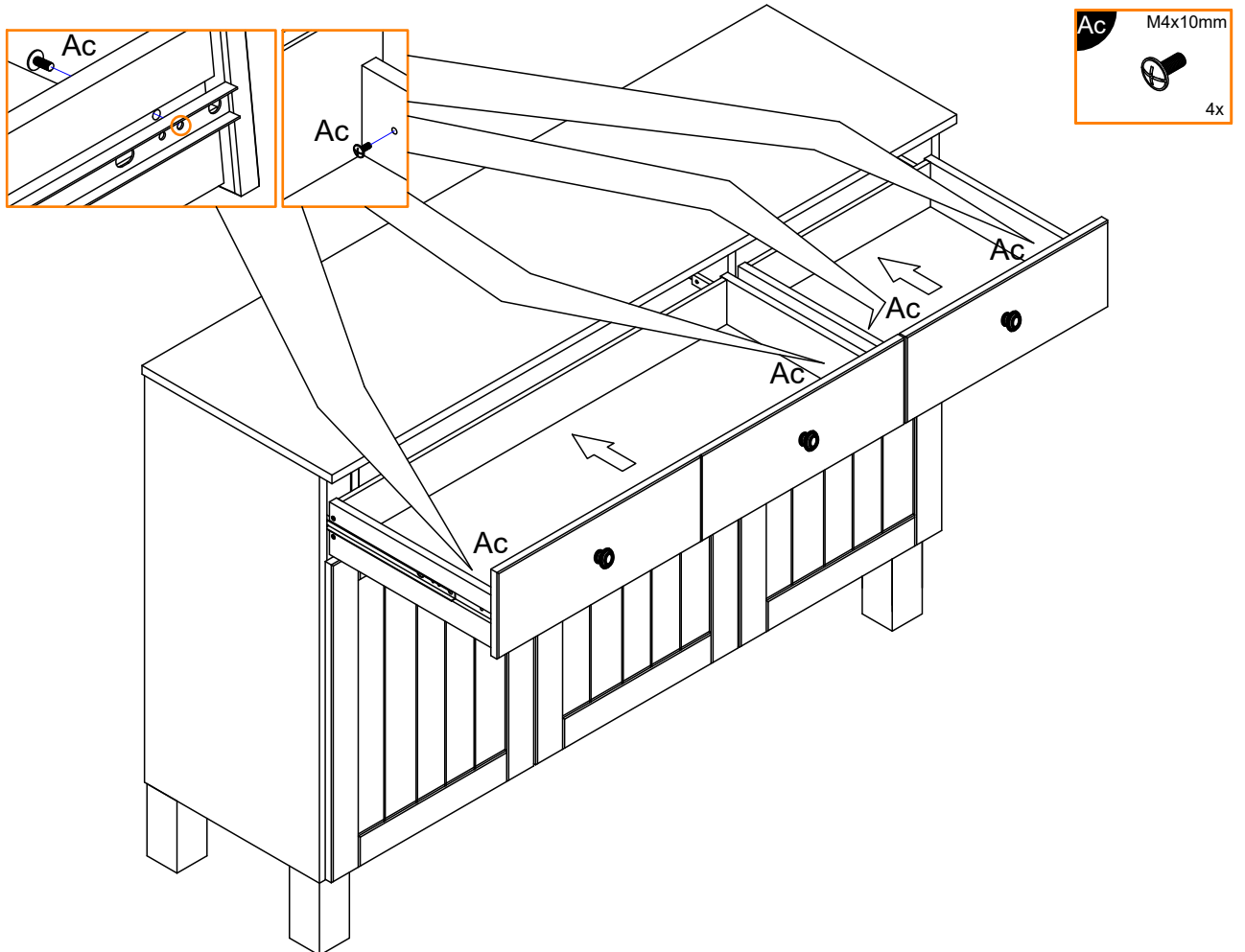

17

Türen einstellen (Scharniere justieren) Vyrovnajte dvířka (seřďte závěsy)
 Adjusting the doors (adjusting the hinges) Nastavenie dverí (nastavenie závesov)
 Régler les portes (ajuster les charnières) Állítsa be az ajtókat (állítsa be a zsanérokat)
 Sistemare le porte (regolare le cerniere) Reglare ușii (ajustare balamale)
 Deuren instellen (scharnieren afstellen) Kapıların ayarlanması (menteşelerin seviye ayarı)
 Nastawić drzwi (wyregulować zawiasy) Регулировка дверей (регулировка шарнира)

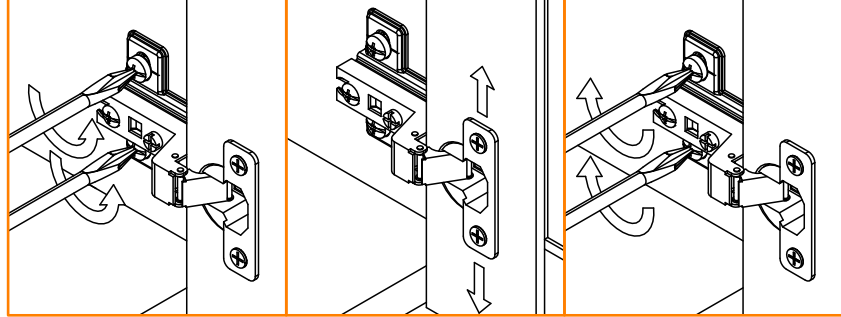
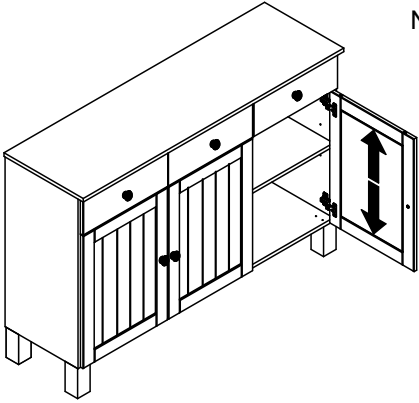

18

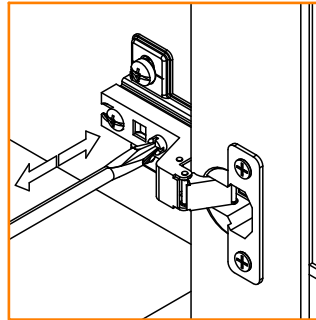
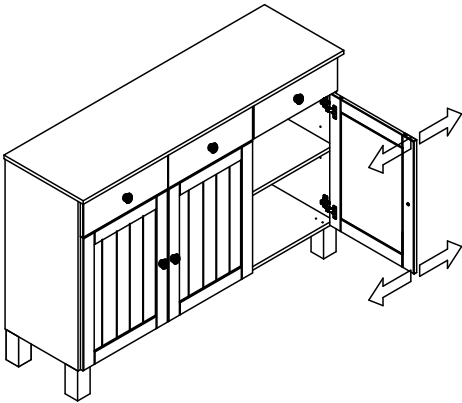

19

