

# ASSEMBLY INSTRUCTIONS /MONTAGEANLEITUNGEN

ADMD-029

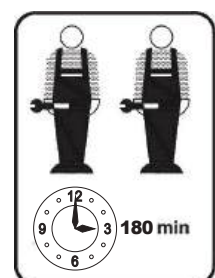
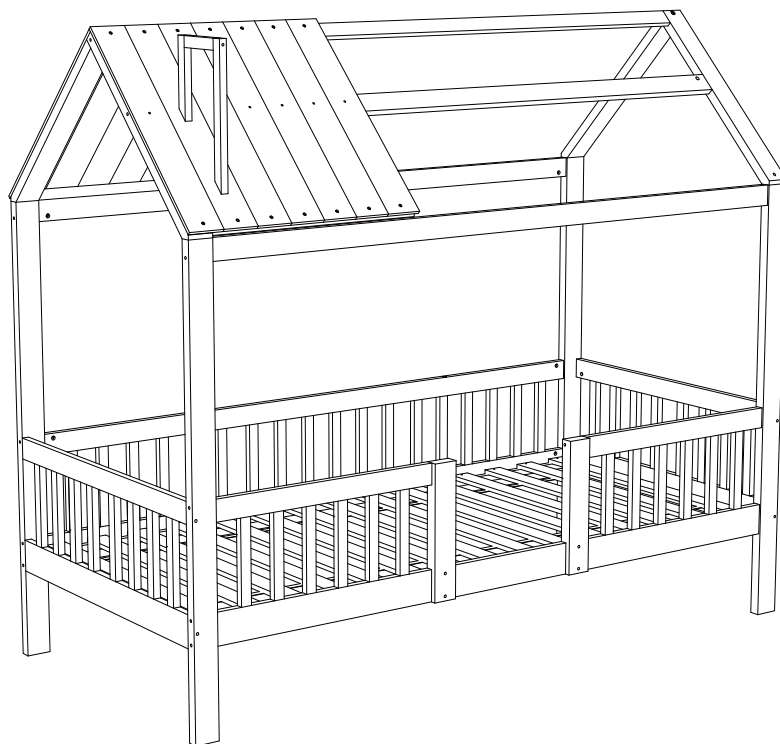

**FR - Notice de montage / EN - Assembly instructions / PT - Instruções de montagem /  
ES - Prospecto de montaje / DE - Montageanleitung / IT - Istruzioni di montaggio /  
NL - Montagehandleiding**

**FR - IMPORTANT! CONSERVER POUR CONSULTATION ULTERIEURE: LIRE ATTENTIVEMENT**

- A monter par un adulte. Un adulte doit vérifier le bon assemblage avant l'emploi
- ATTENTION! tenir les vis et petits éléments et sachets hors de portée des enfants
- Bien identifier les éléments avant de commencer le montage
- Ne pas utiliser votre article lorsque l'un de ses éléments est cassé ou manquant
- En cas de problème contactez notre service après-vente
- Toujours suivre les instructions du fabricant
- Entretien: nettoyer avec un chiffon doux et sec. En cas de taches plus grosses, frottez soigneusement avec une éponge légèrement humide et non abrasive
- Ne pas sauter sur le lit

**EN - IMPORTANT! KEEP FOR FUTURE REFERENCE: READ CAREFULLY**

- To be assembled by an adult. Assembly must be checked by an adult before use
- WARNING! keep all screws, small parts and plastic bags out of the reach of children
- Properly identify all parts before assembling
- Never use your item if any of its parts are broken or missing
- Should any problems arise, please contact our After Sales Service
- Manufacturer's instructions shall be followed at all times
- Care: clean with a soft, dry cloth. In case of larger stains, carefully rub with a slightly damp, non-abrasive sponge
- Do not jump on the bed

**PT - IMPORTANTE! GUARDE PARA CONSULTA POSTERIOR: LER ESTAS INSTRUÇÕES CUIDADOSAMENTE**

- A ser montado por um adulto. Um adulto deve verificar a boa montagem antes da utilização
- Atenção! mantenha os parafusos, acessórios pequenos e saco de plástico fora do alcance das crianças
- Identifique bem os acessórios antes de começar a montagem
- Não utilizar o artigo se um dos elementos está em falta ou danificado
- Para qualquer esclarecimento, contacte os nossos serviços através do telefone
- As instruções do fabricante devem ser sempre cumpridas
- Manutenção: limpe com um pano macio e seco. Em caso de manchas maiores, esfregue cuidadosamente com uma esponja ligeiramente húmida e não abrasiva
- Não salte na cama

**ES - IMPORTANTE! CONSERVAR PARA FUTURAS CONSULTAS: LEER DETENIDAMENTE**

- A montar por un adulto. Un adulto debe comprobar el buen montaje antes de la utilización
- ¡ADVERTENCIA! mantener los tornillos, los pequeños elementos y bolsitas fuera del alcance de los niños
- Identificar debidamente los elementos antes de empezar el montaje
- No utilizar este artículo si uno de los elementos falta o esta roto
- Si tiene problemas, contactar nuestro servicio postventa
- Deben seguirse siempre las instrucciones del fabricante Cuidados: limpiar con un paño suave y seco. En caso de manchas grandes, frotar con cuidado utilizando una esponja húmeda no abrasiva
- No saltar sobre la cama

**DE - WICHTIG! FÜR SPÄTERE BEZUGNAHME AUFBEWAHREN: SORGFÄLTIG LESEN**

- Von einem Erwachsenen zu montieren. Die korrekte Montage muss vor Gebrauch von einem Erwachsenen geprüft werden
- Achtung! die Schrauben und kleinen Teile ausserhalb der Reichweite von Kindern lagern
- Vor Montagebeginn alle Teile identifizieren
- Ihren Artikel nicht benutzen, wenn eines seiner Bestandteile beschädigt ist oder fehlt
- Im Problemfall Ihren Kundendienst anrufen
- Stets die Herstelleranweisungen beachten
- Wartung: Mit einem weichen, trockenen Tuch reinigen. Bei größeren Flecken vorsichtig mit einem leicht feuchten, nicht scheuernden Schwamm abreiben
- Nicht auf dem Bett springen

**IT - IMPORTANTE! CONSERVARE QUESTE INFORMAZIONI PER ULTERIORI CONSULTAZIONI: LEGGI ATTENTAMENTE**

- Il montaggio deve essere eseguito da un adulto. Un adulto dovrà verificare il corretto montaggio prima dell'uso
- ATTENZIONE! tenere le viti ed i componenti di piccole dimensioni lontano dalla portata dei bambini
- Controllare i pezzi prima del montaggio
- L'articolo non deve essere utilizzato in caso di elementi mancanti o danneggiati
- In caso di necessità contattare il nostro servizio post-vendita
- Seguire sempre le istruzioni del costruttore
- Manutenzione: pulire con un panno morbido e asciutto. Per le macchine più grandi, strofinare accuratamente con una spugna leggermente umida e non abrasiva
- Non saltare sul letto







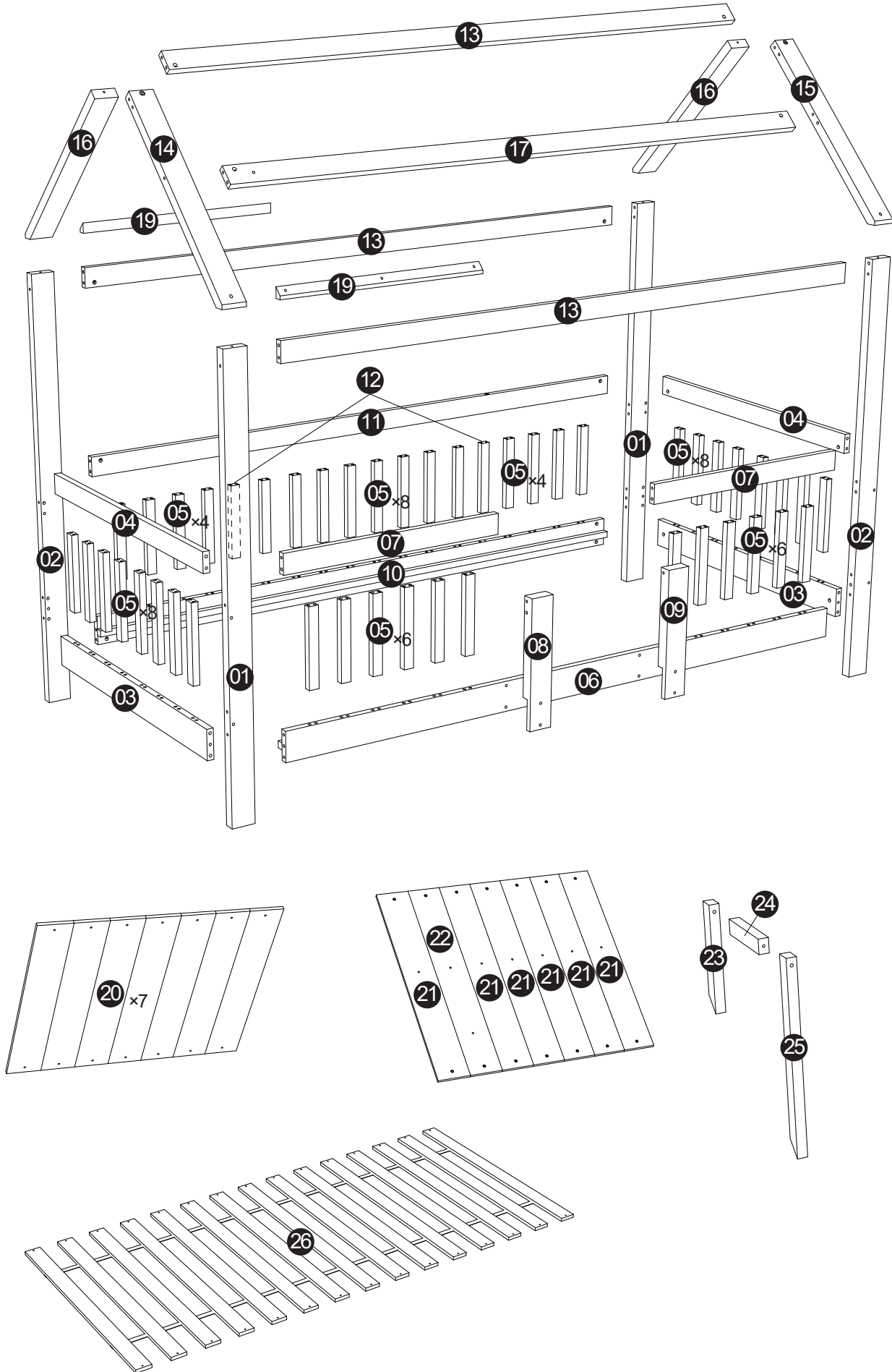







**NL - BELANGRIJK! BEWAAR VOOR LATERE RAADPLEGING: LEES AANDACHTIG**

- Moet door een volwassene worden gemonteerd. Voor gebruik moet een volwassene controleren dat het product goed in elkaar is gezet
- WAARSCHUWING! schroeven en kleine elementen en zakjes buiten bereik van kinderen houden
- De elementen goed identificeren alvorens met de montage te beginnen
- Uw artikel niet gebruiken wanneer een van de onderdelen kapot is of ontbreekt
- Neem bij problemen contact op met onze klantenservice
- Volg altijd de instructies van de fabrikant
- Onderhoud: maak schoon met een zachte en droge doek. In geval van grotere vlekken, veeg voorzichtig schoon met een licht bevochtigde en niet-schurende spons
- Niet springen op het bed

# Stückliste



# 231223SHJ0101-1-21

A	 M6 x 70mm	8	I	 $\Phi 6 \times 110\text{mm}$	2
B		30	J	 $\Phi 6 \times 70\text{mm}$	2
C	 $\Phi 8 \times 30\text{mm}$	210	K	 $\Phi 6 \times 50\text{mm}$	4
D		2	L	 $\Phi 4 \times 30\text{mm}$	37
E	 M6 x 120mm	22	M	 $\Phi 4 \times 20\text{mm}$	34
F		4	N	 $\Phi 7 \times 60\text{mm}$	2
G	 M6 x 30mm	4	O	 $\Phi 4 \times 50\text{mm}$	1
H	 $\Phi 6 \times 90\text{mm}$	2			







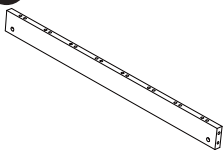
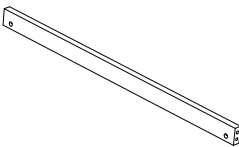
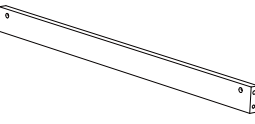
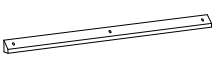
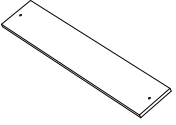
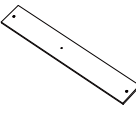
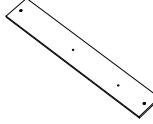
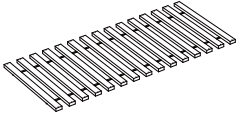

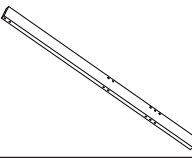
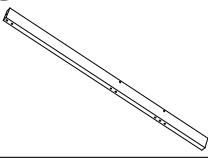

## Wichtiger Hinweis:

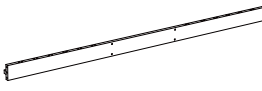
Bestätigen Sie bitte alle Komponenten und Schrauben vor der Montage. Bitte wenden Sie sich an uns, falls einige Teile oder Schrauben im Paket fehlt sind.

## 231223SHJ0101-1-21



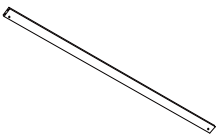
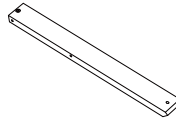
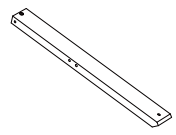

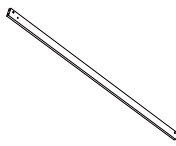
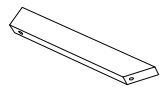
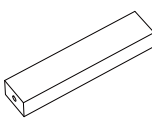
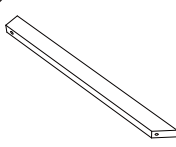
<p>03x2</p> 	<p>04x2</p> 	<p>07x2</p> 	<p>19x2</p> 	<p>20x7</p> 
<p>21x6</p> 	<p>22x1</p> 	<p>26x1</p> 		

## 231223SHJ0101-1-22

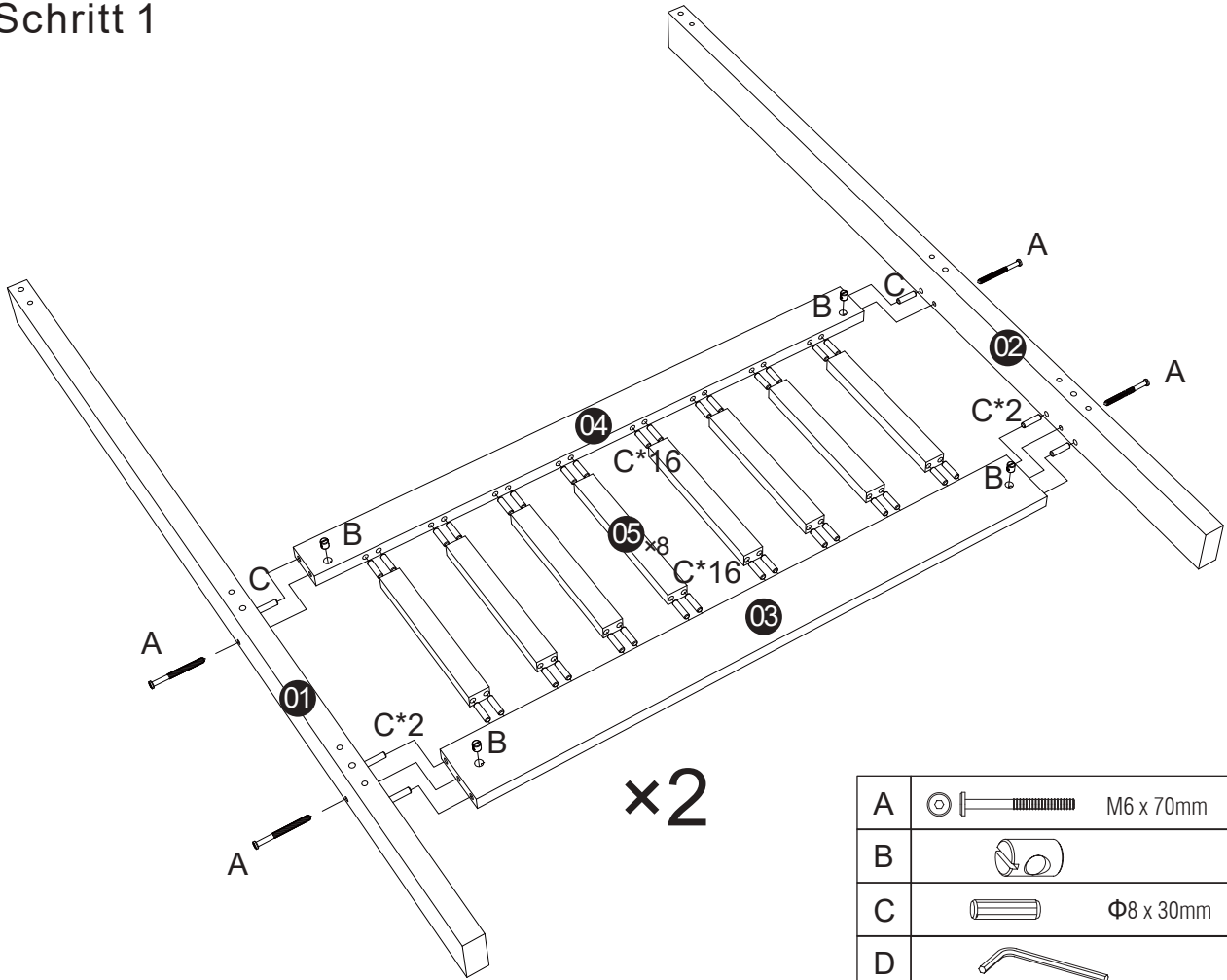
<p>01x2</p> 	<p>02x2</p> 	<p>05x44</p> 	<p>06x1</p> 	<p>08x1</p> 
<p>09x1</p> 	<p>10x1</p> 	<p>11x1</p> 	<p>12x2</p> 	<p>13x3</p> 
<p>14x1</p> 	<p>15x1</p> 	<p>16x2</p> 	<p>17x1</p> 	<p>23x1</p> 
<p>24x1</p> 	<p>25x1</p> 			







# Schritt 1

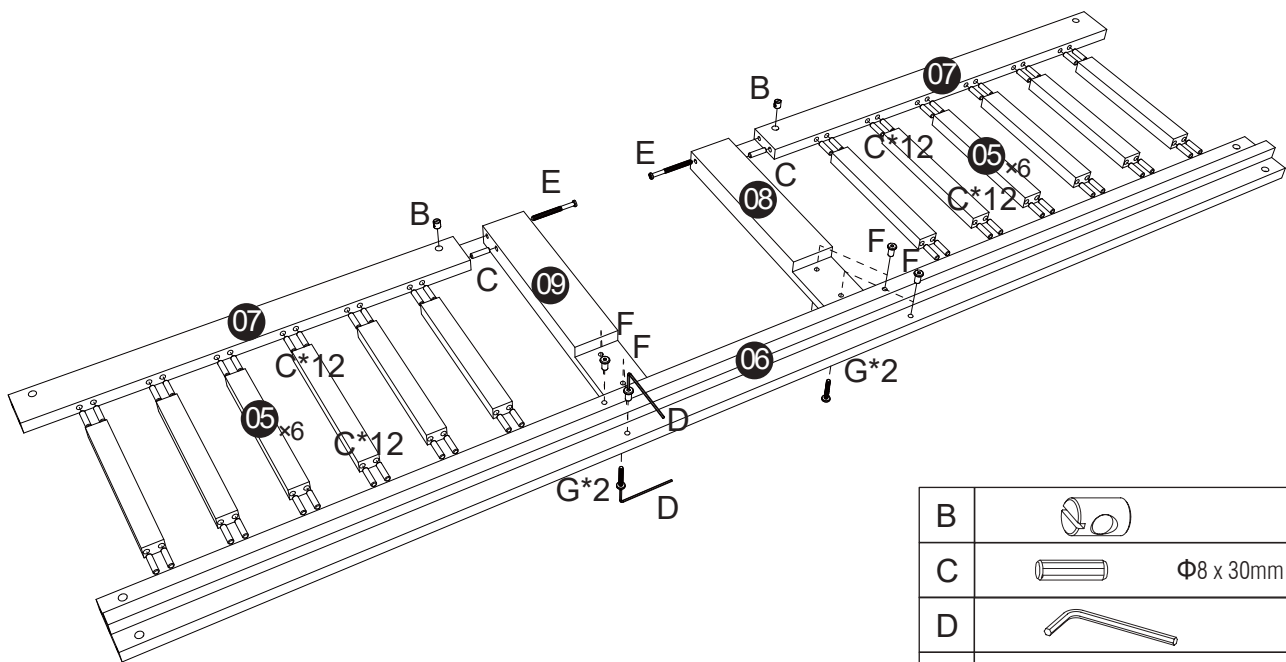

A		M6 x 70mm	8
B			8
C		Φ8 x 30mm	76
D			1

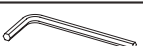
# Schritt 2





B			2
C		Φ8 x 30mm	50
D			2
E		M6 x 120mm	2
F			4
G		M6 x 30mm	4



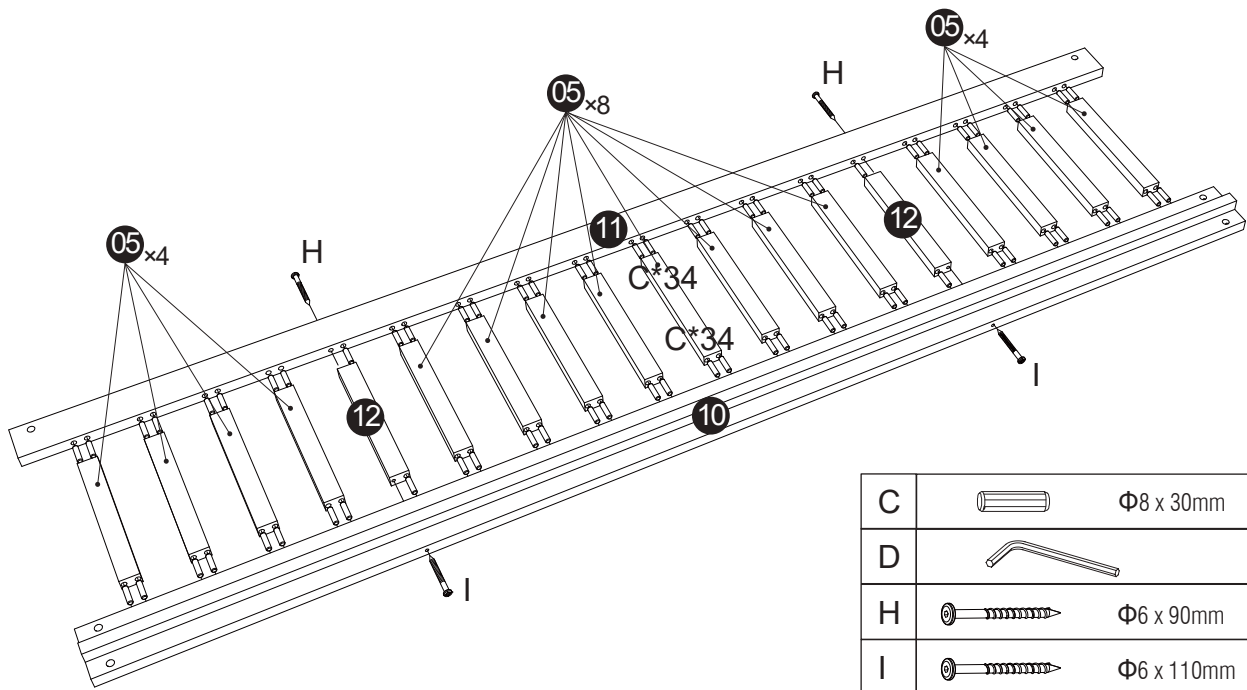

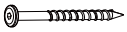
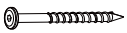

### Schritt 3

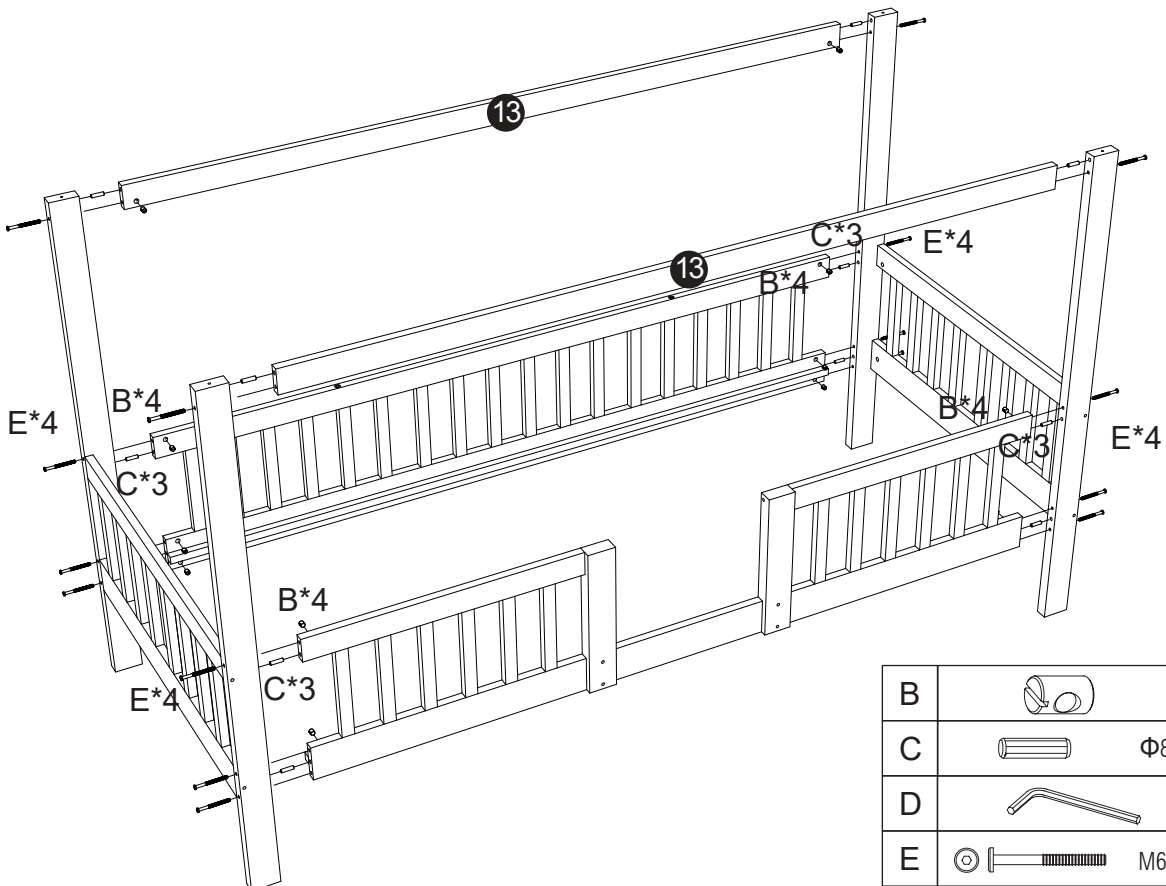

C		Φ8 x 30mm	68
D			1
H		Φ6 x 90mm	2
I		Φ6 x 110mm	2

### Schritt 4



B			16
C		Φ8 x 30mm	12
D			1
E		M6 x 120mm	16



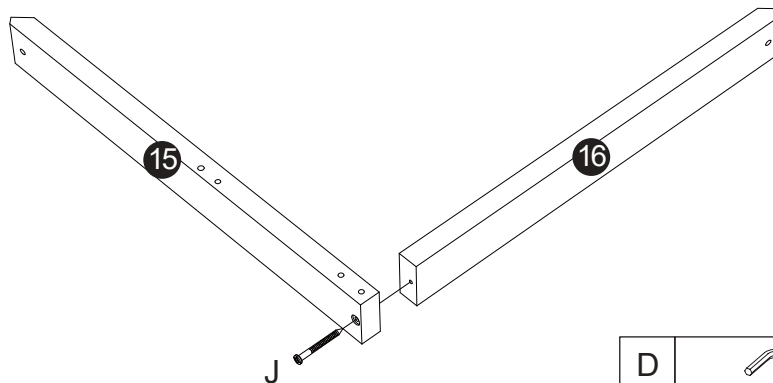
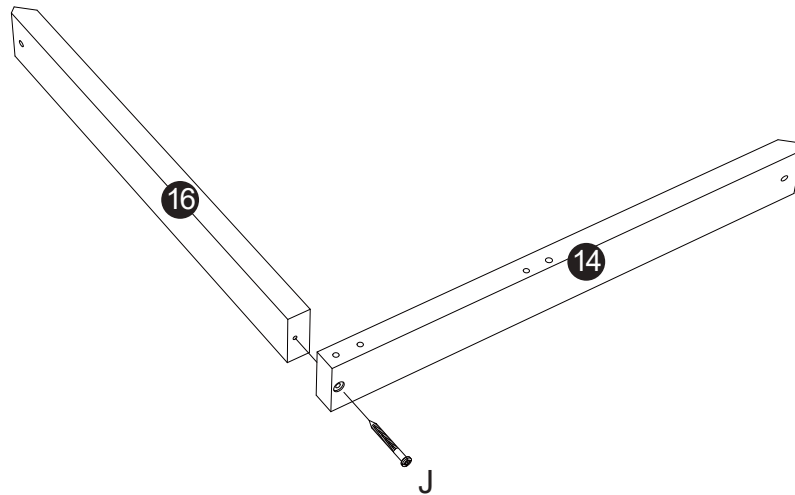

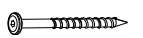
## Schritt 5

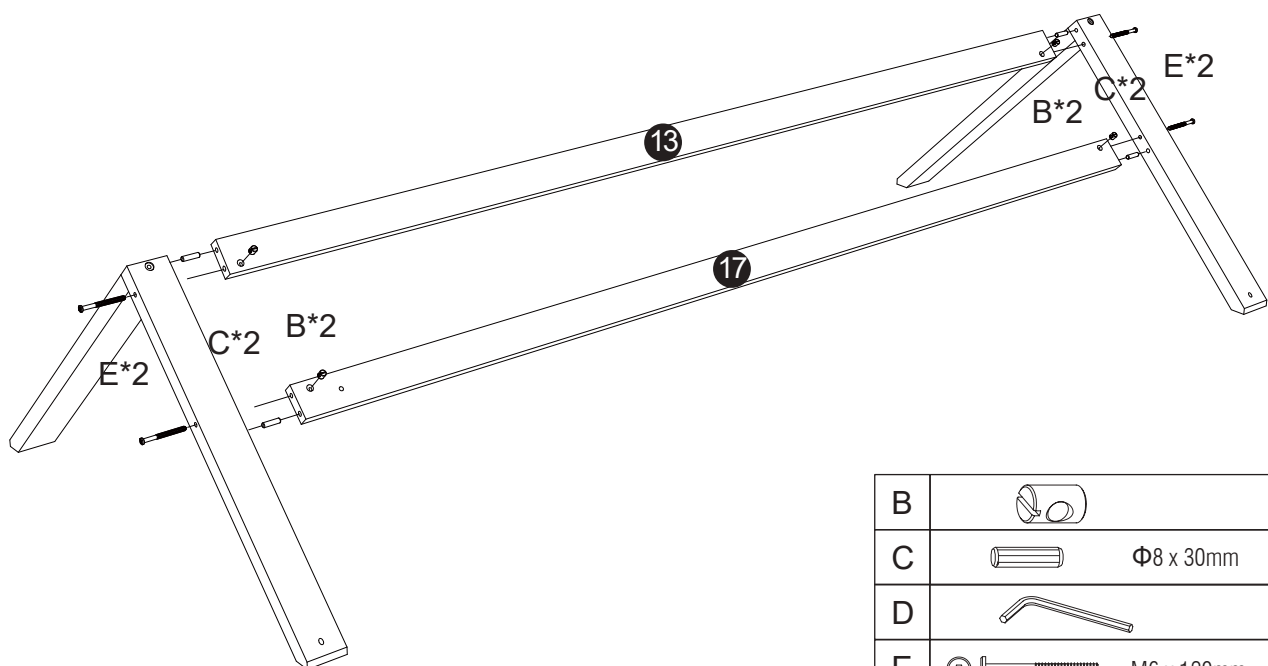

D			1
J		Φ6 x 70mm	2

## Schritt 6



B			4
C		Φ8 x 30mm	4
D			1
E		M6 x 120mm	4



## Schritt 7

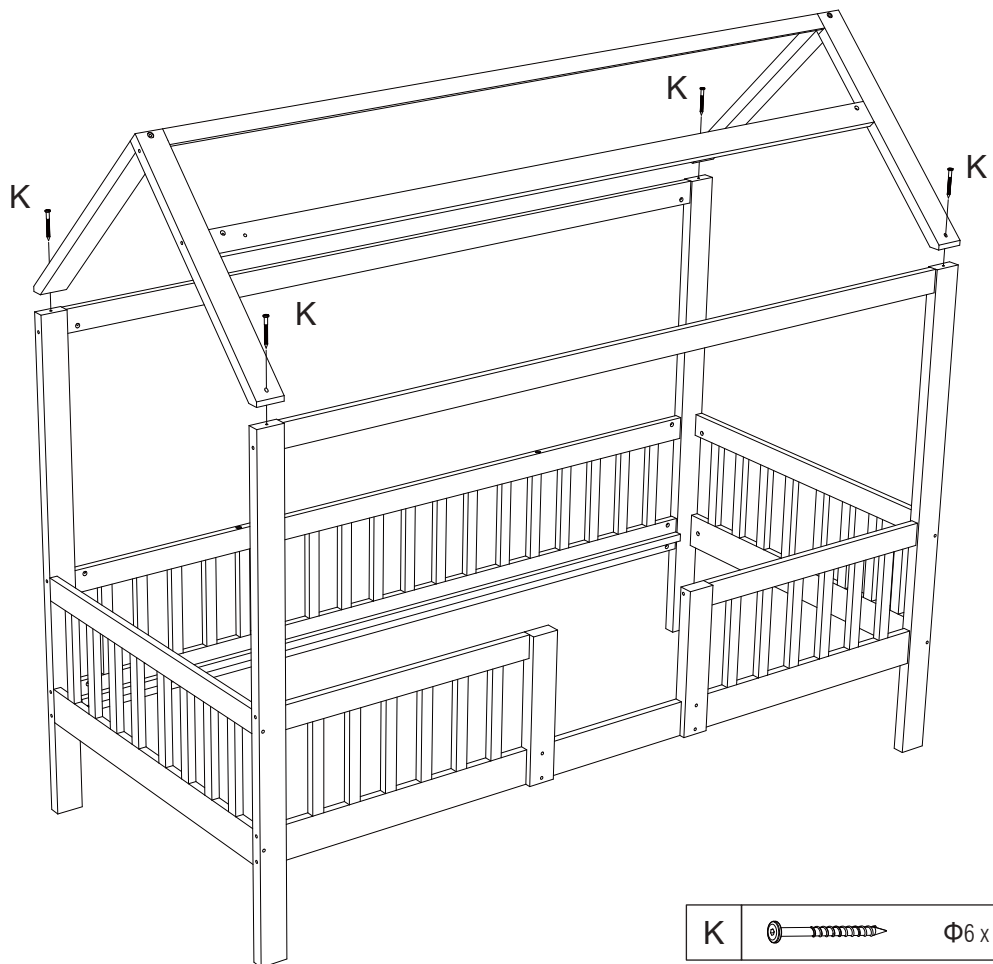

K		Φ6 x 50mm	4
---	---	-----------	---

## Schritt 8

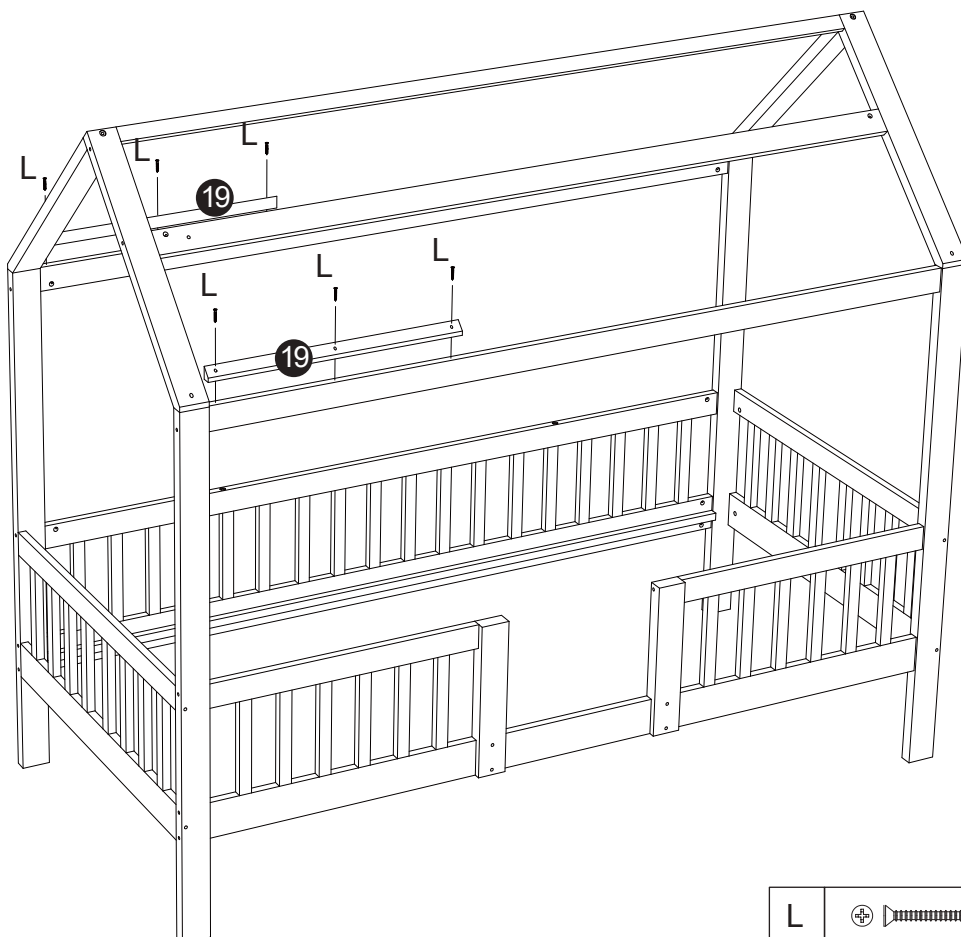

L		Φ4x30mm	6
---	---	---------	---

## Schritt 9

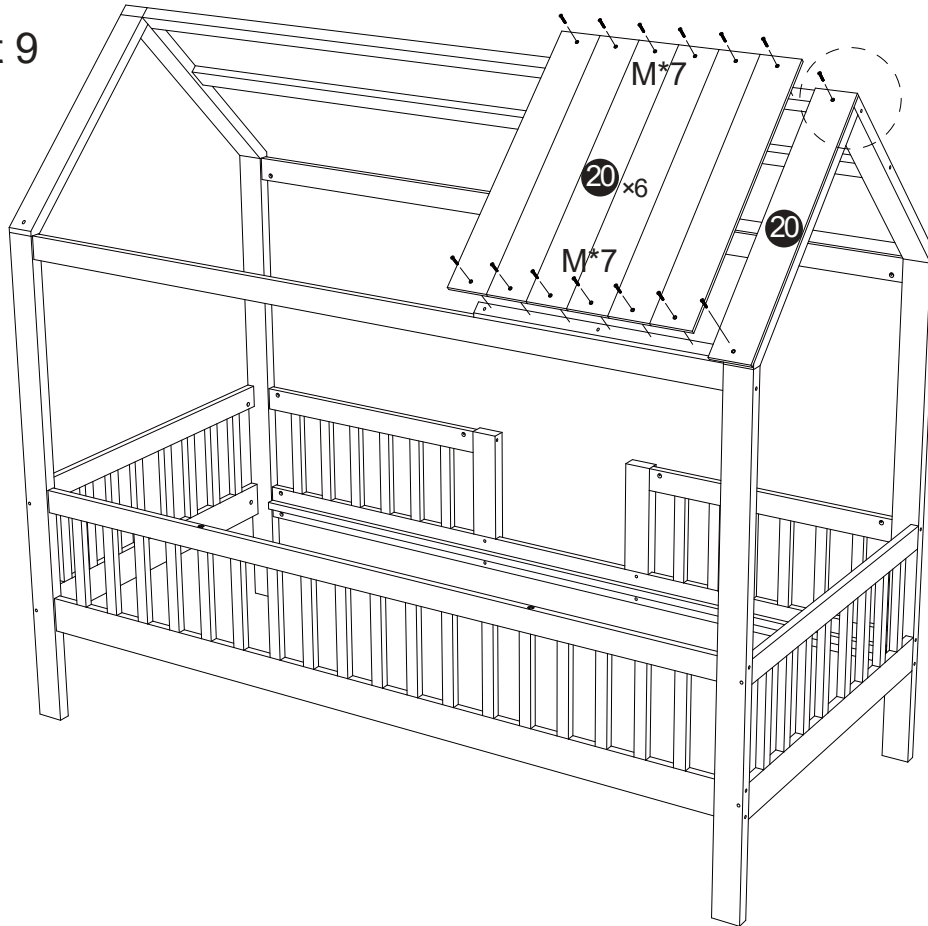

M		$\Phi 4 \times 20 \text{mm}$	14
---	---	------------------------------	----

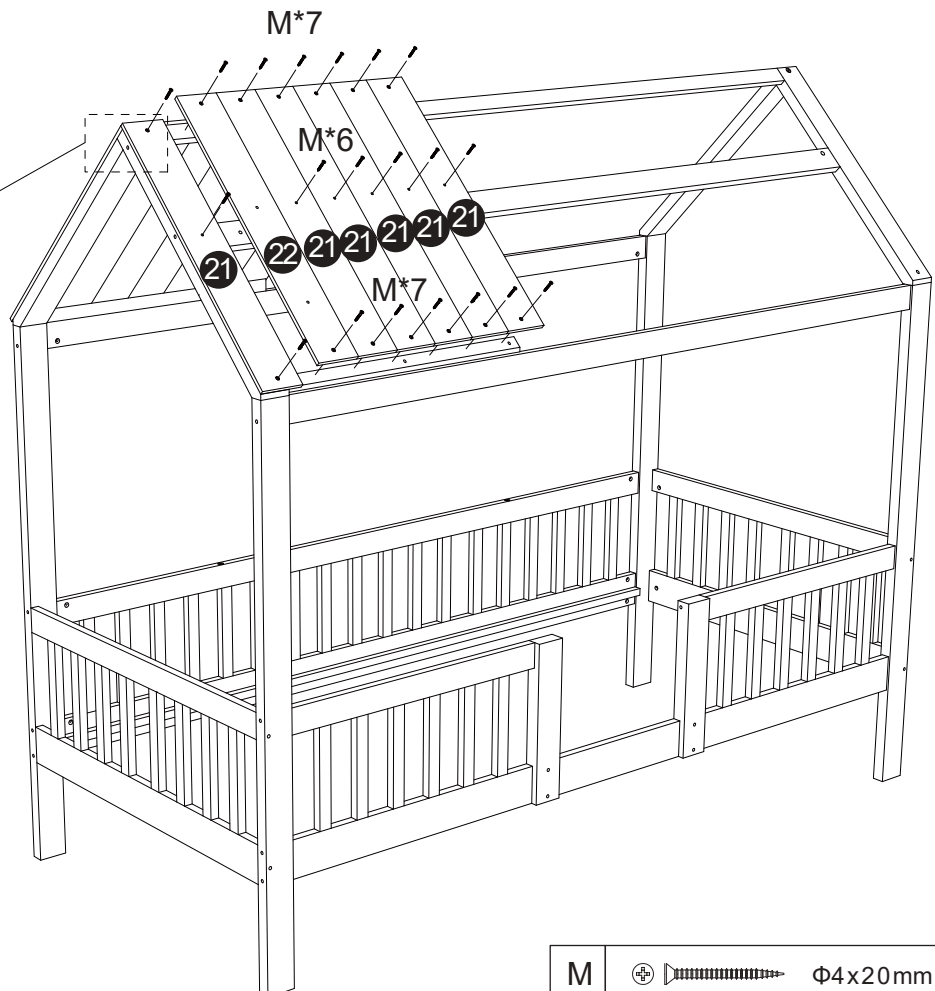
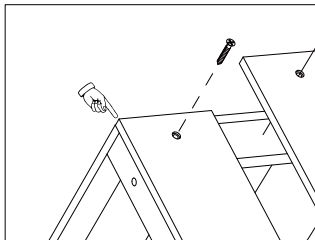

## Schritt 10



M		$\Phi 4 \times 20 \text{mm}$	20
---	---	------------------------------	----

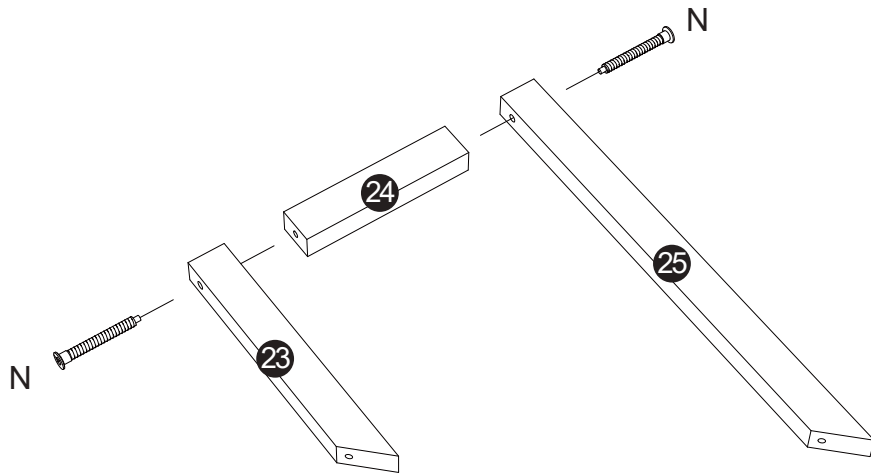

## Schritt 11



D		1
N	 $\Phi 7 \times 60 \text{mm}$	2

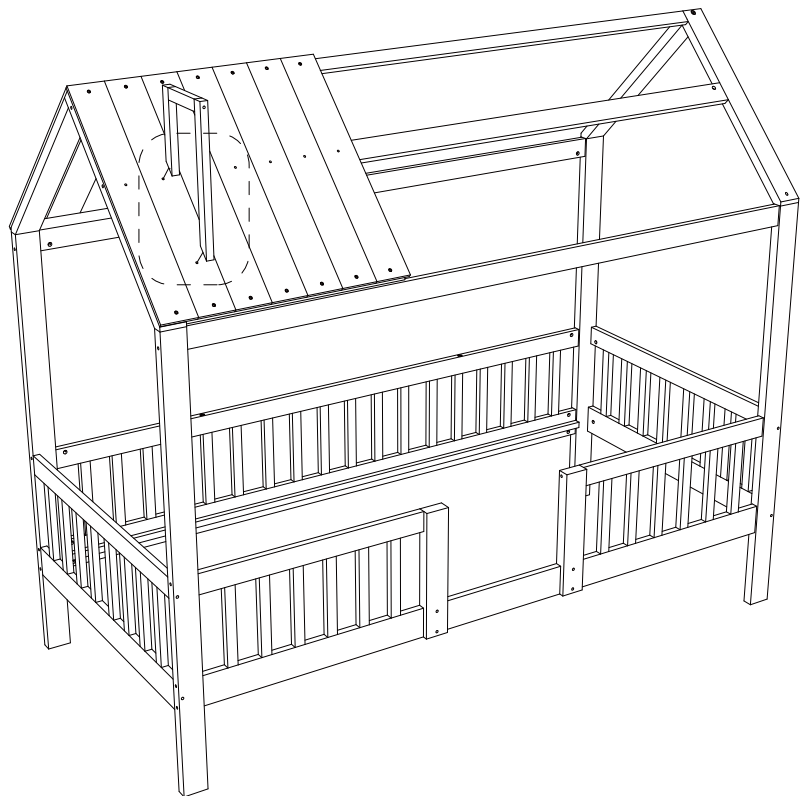
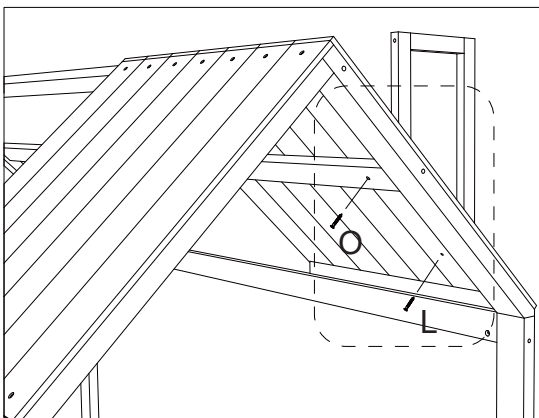

## Schritt 12

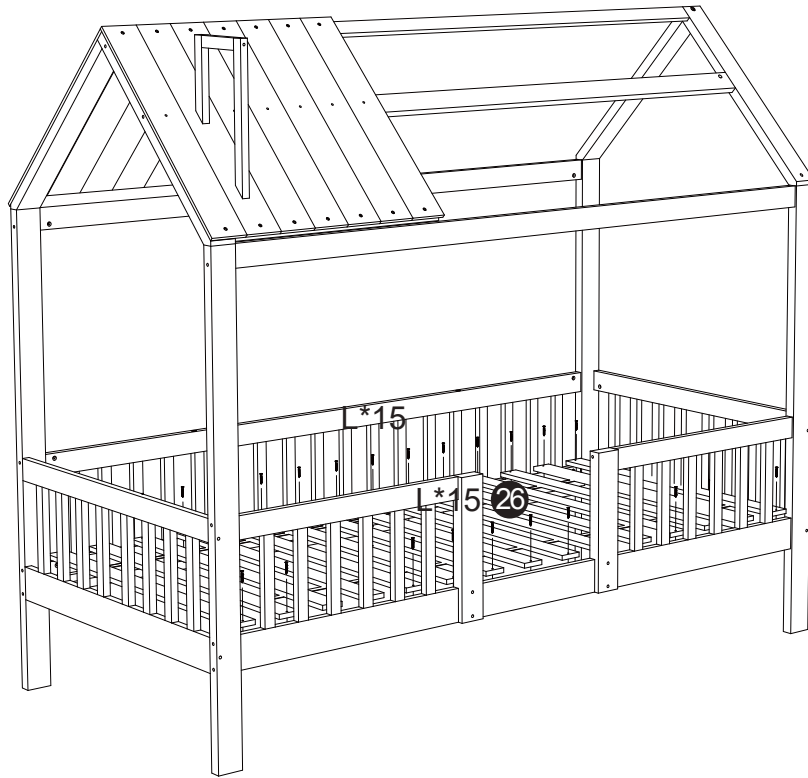

L	 $\Phi 4 \times 30 \text{mm}$	1
O	 $\Phi 4 \times 50 \text{mm}$	1

## Schritt 13



L			Φ4x30mm	30
---	---	---	---------	----

## Schritt 14

