

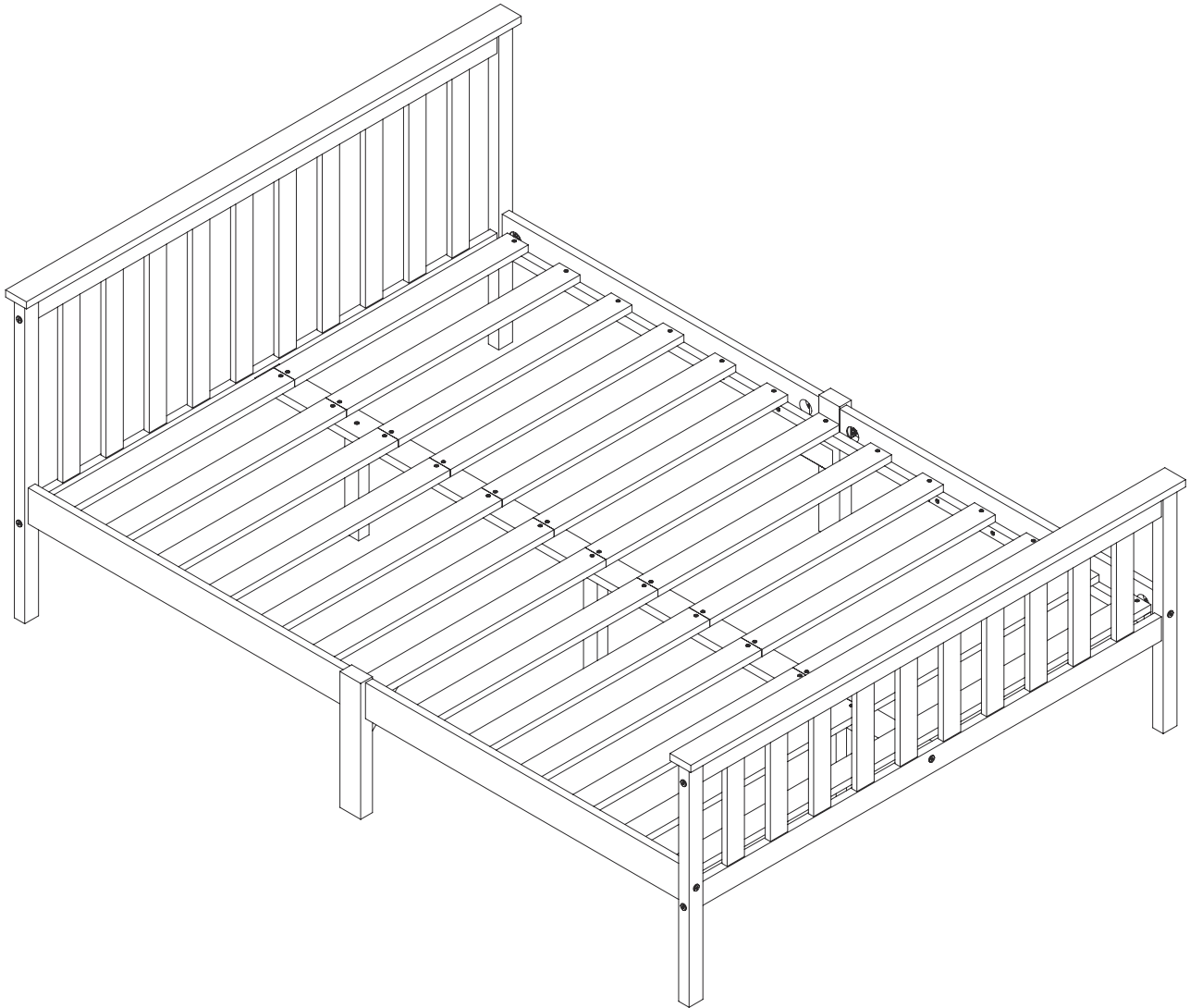

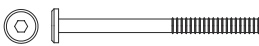









# WF192321WAA

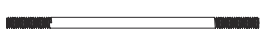

<p>A x4</p>  <p>M6x90</p>	<p>B x4</p> 	<p>C x108</p>  <p>Φ8x30</p>	<p>D x4</p>  <p>Φ6x90</p>	<p>E x8</p>  <p>Φ7x85</p>
<p>F x10</p>  <p>M6x70</p>	<p>G x2</p> 	<p>H x8</p> 	<p>J x86</p>  <p>Φ4x30</p>	<p>K x2</p> 
<p>L x1</p> 	<p>M x4</p>  <p>Φ7x50</p>	<p>N x2</p>  <p>Φ6x70</p>		

# Stückliste

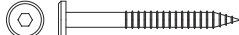
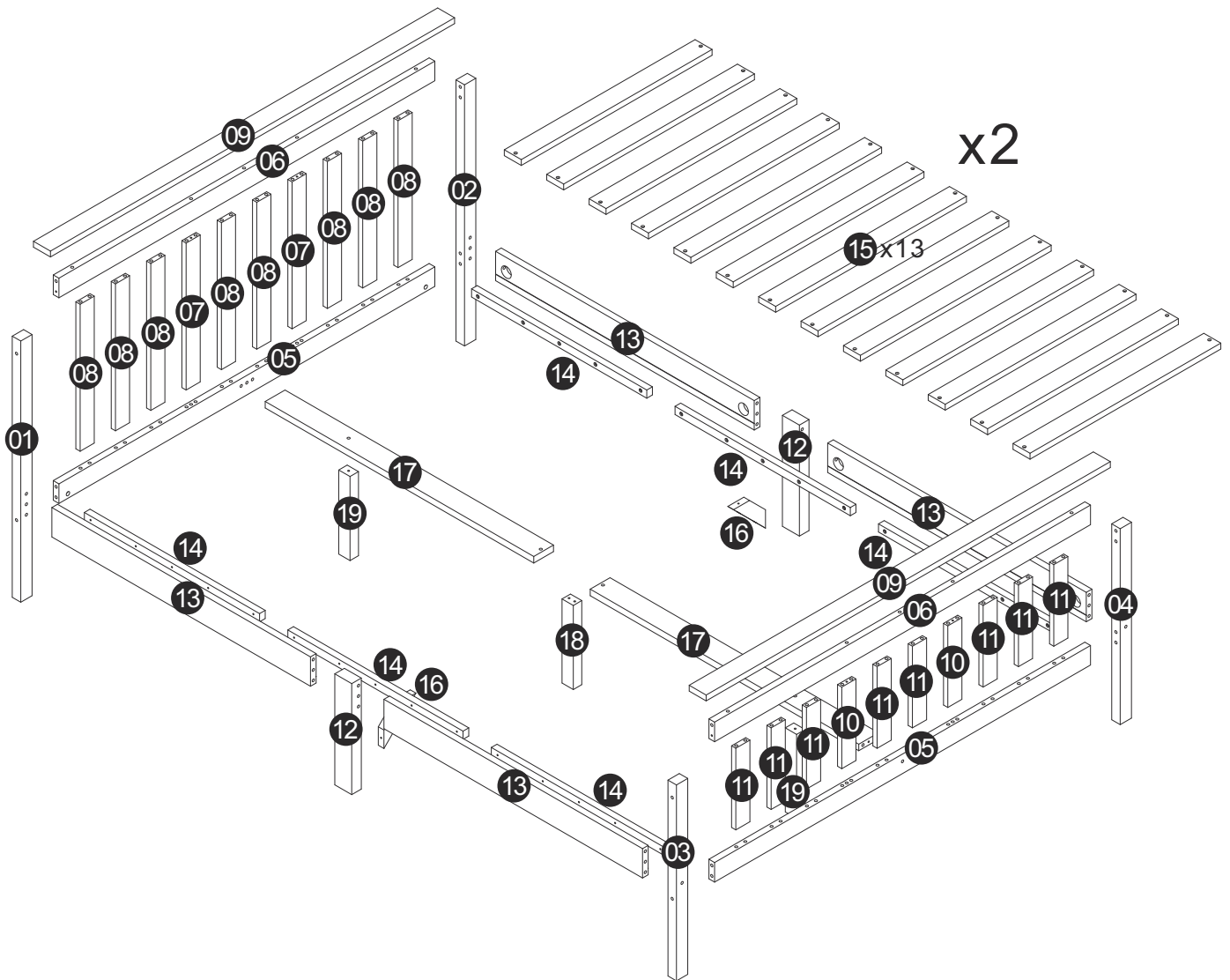

Nr.	Menge	Beschreibung
01	1	Bett Bein
02	1	Bett Bein
03	1	Bett Bein
04	1	Bett Bein
05	2	Untere Kreuzschiene
06	2	Obere Kreuzschiene
07	2	Kopfstütze i
08	8	Kopfstütze i
09	2	Kopfbrett
10	2	Schwanz Unterstützung

Nr.	Menge	Beschreibung
11	8	Schwanz Unterstützung
12	2	seitenbein
13	4	Bett Seite
14	6	Unterstützung am Bett
15	26	Betlatte
16	2	Seitliche Unterstützung
17	2	Bettklammern
18	1	Mittelbeinig
19	2	Mittelbeinig

# Schritt 1

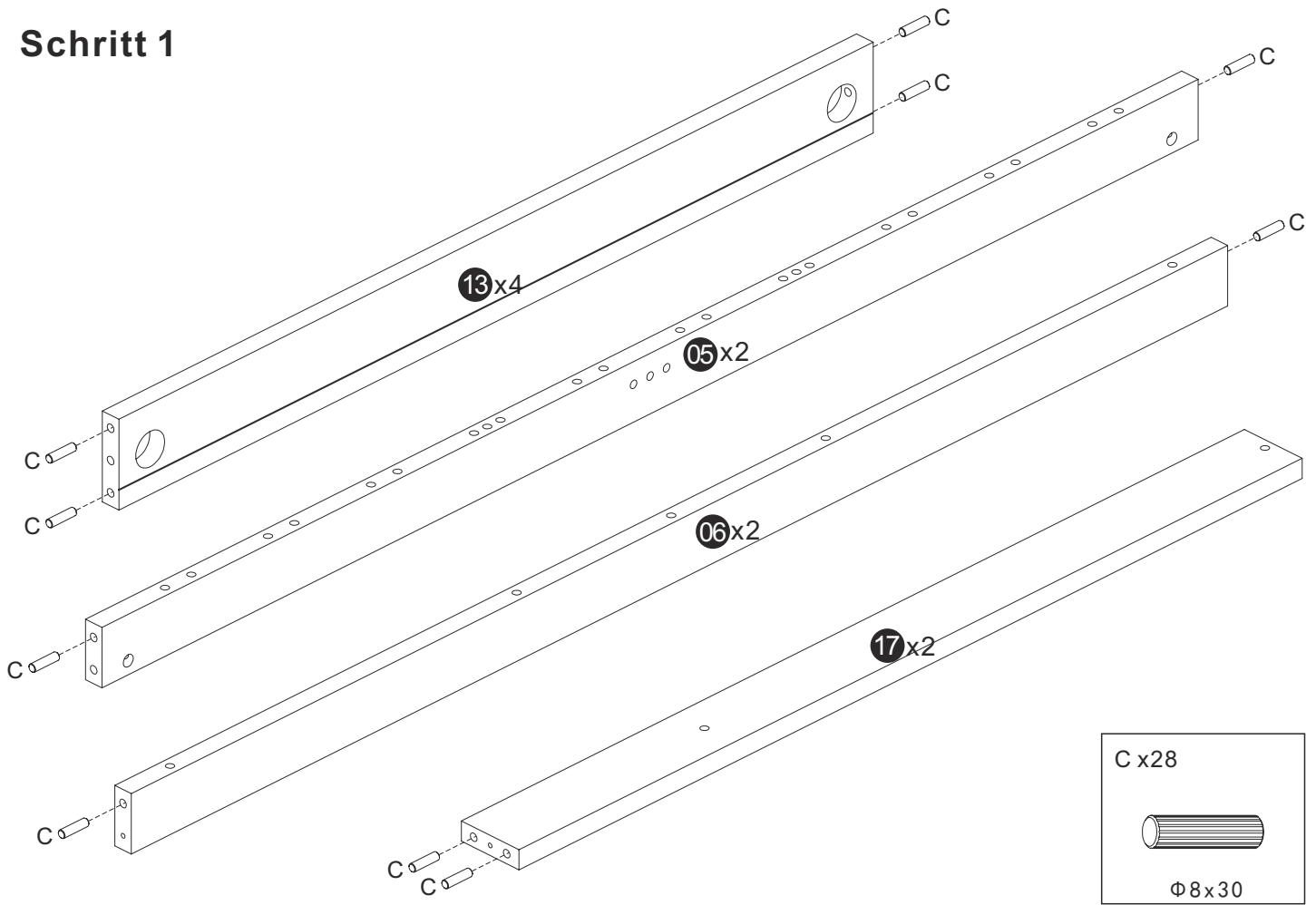

# Schritt 2

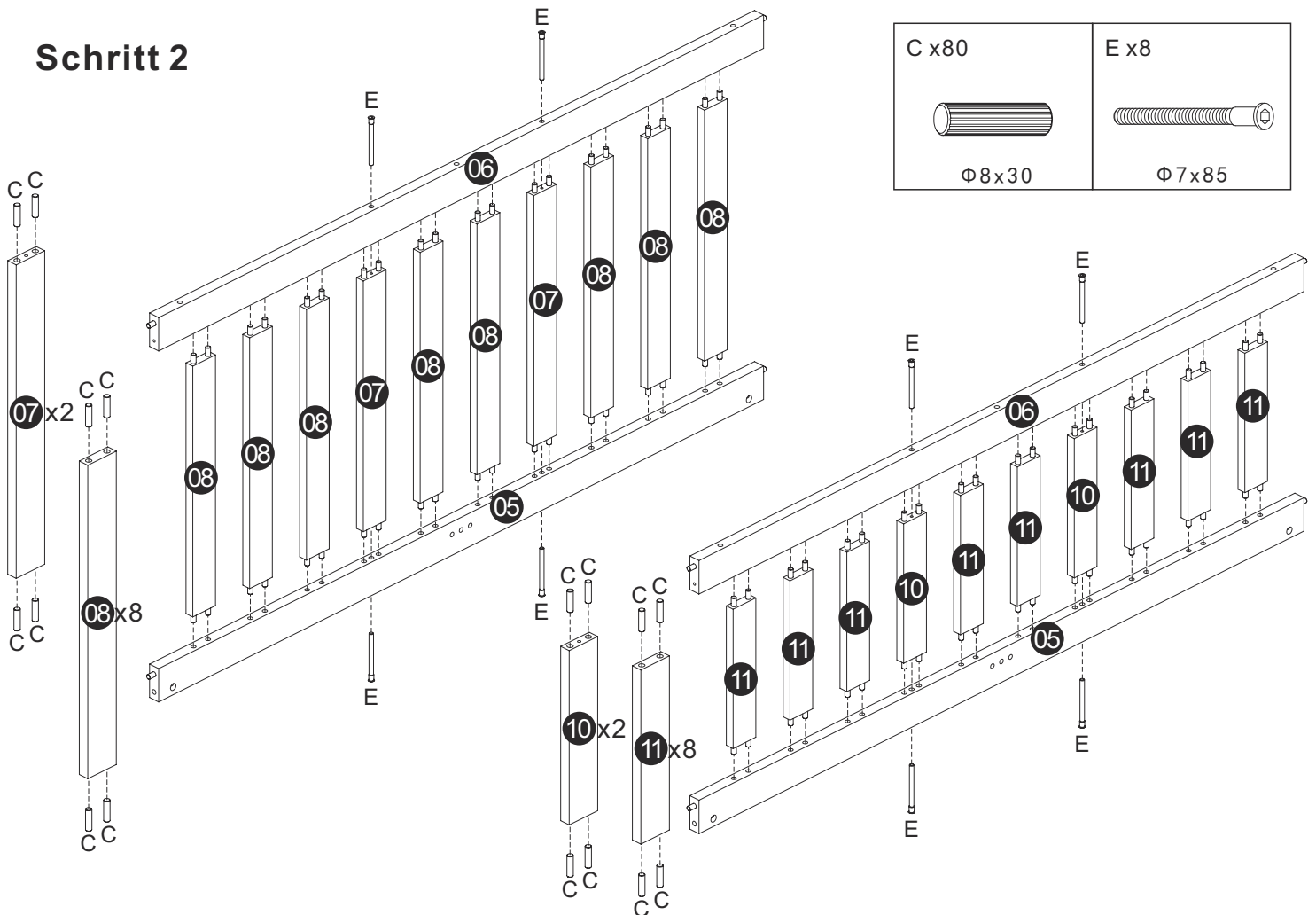

### Schritt 3

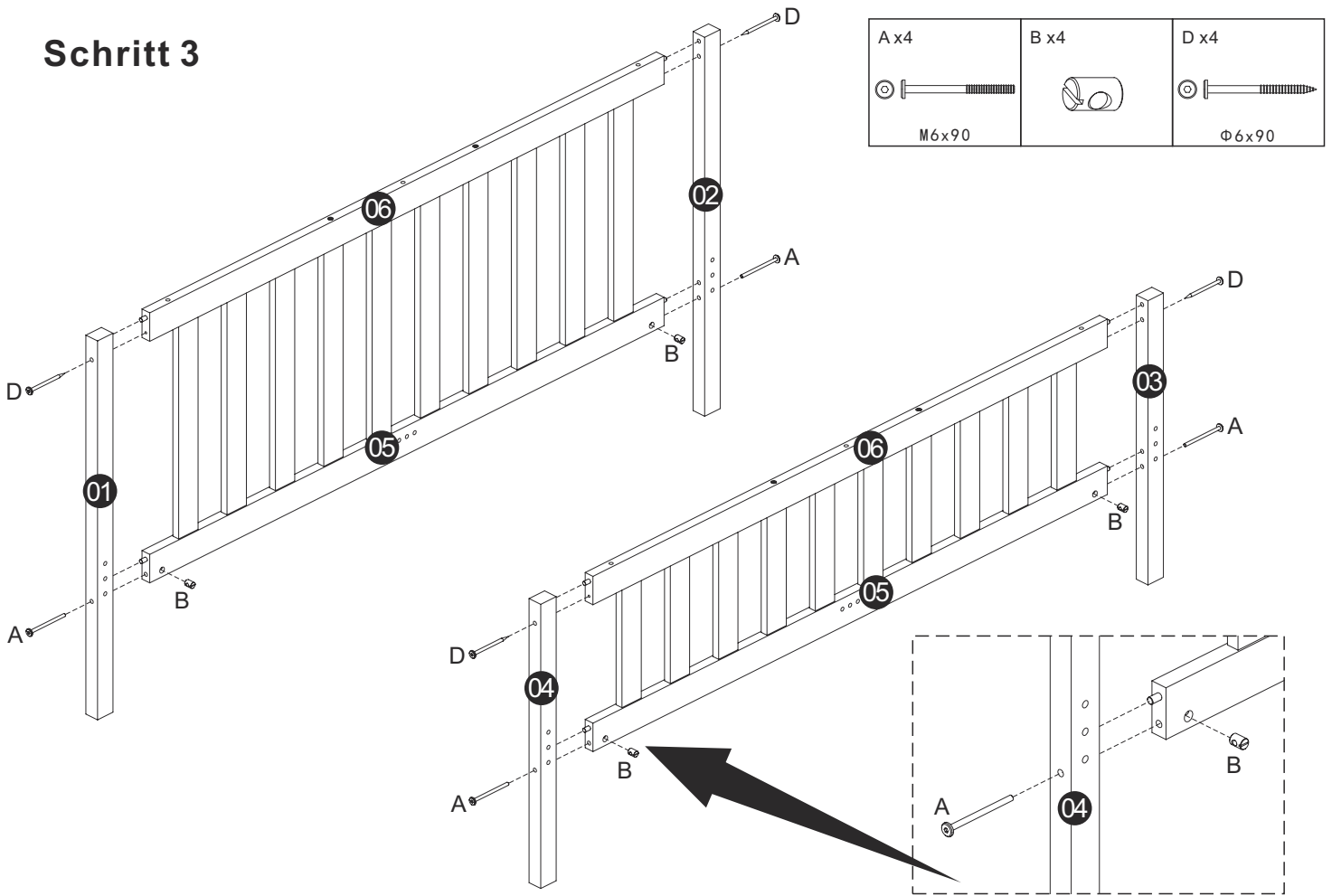

### Schritt 4

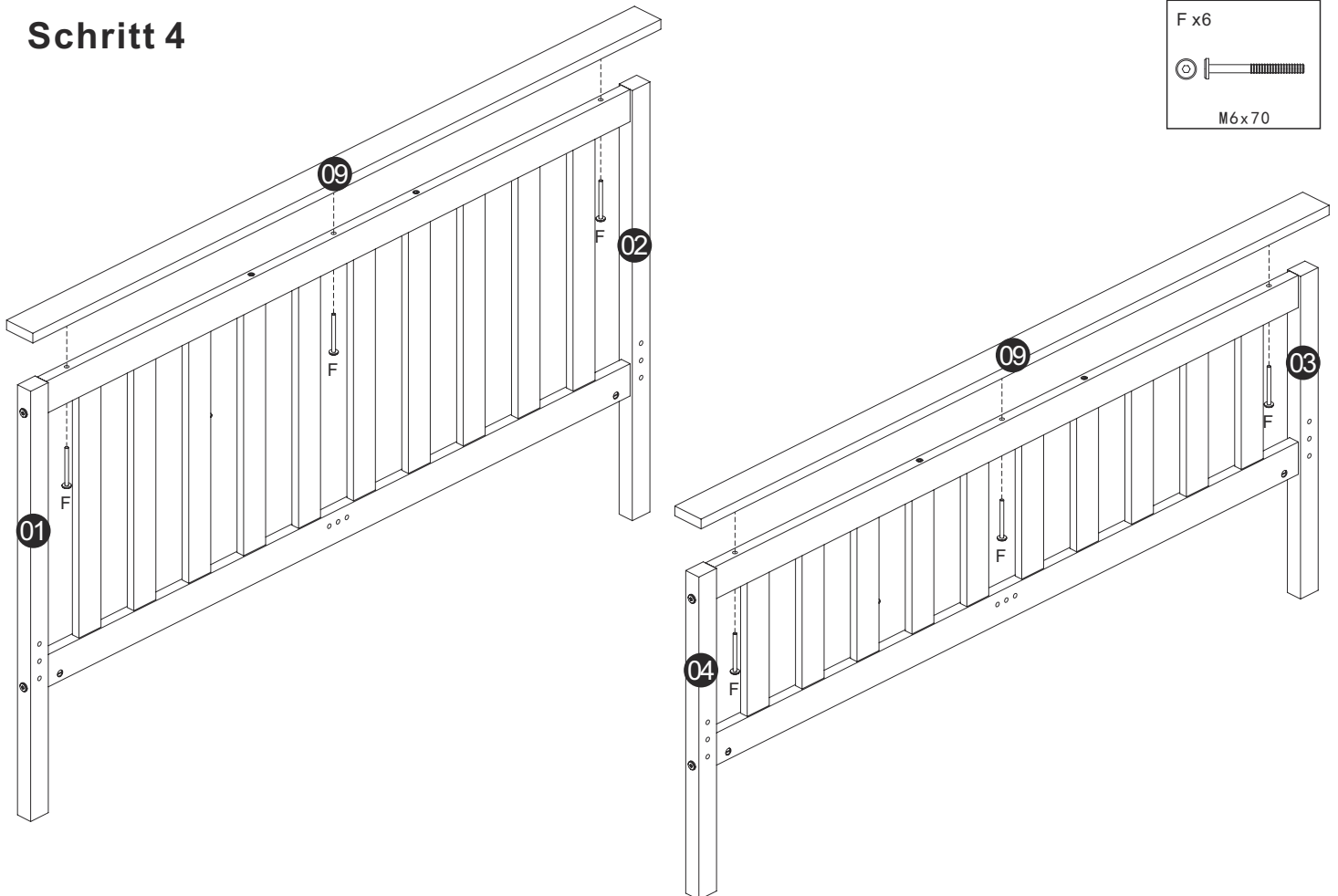

## Schritt 5

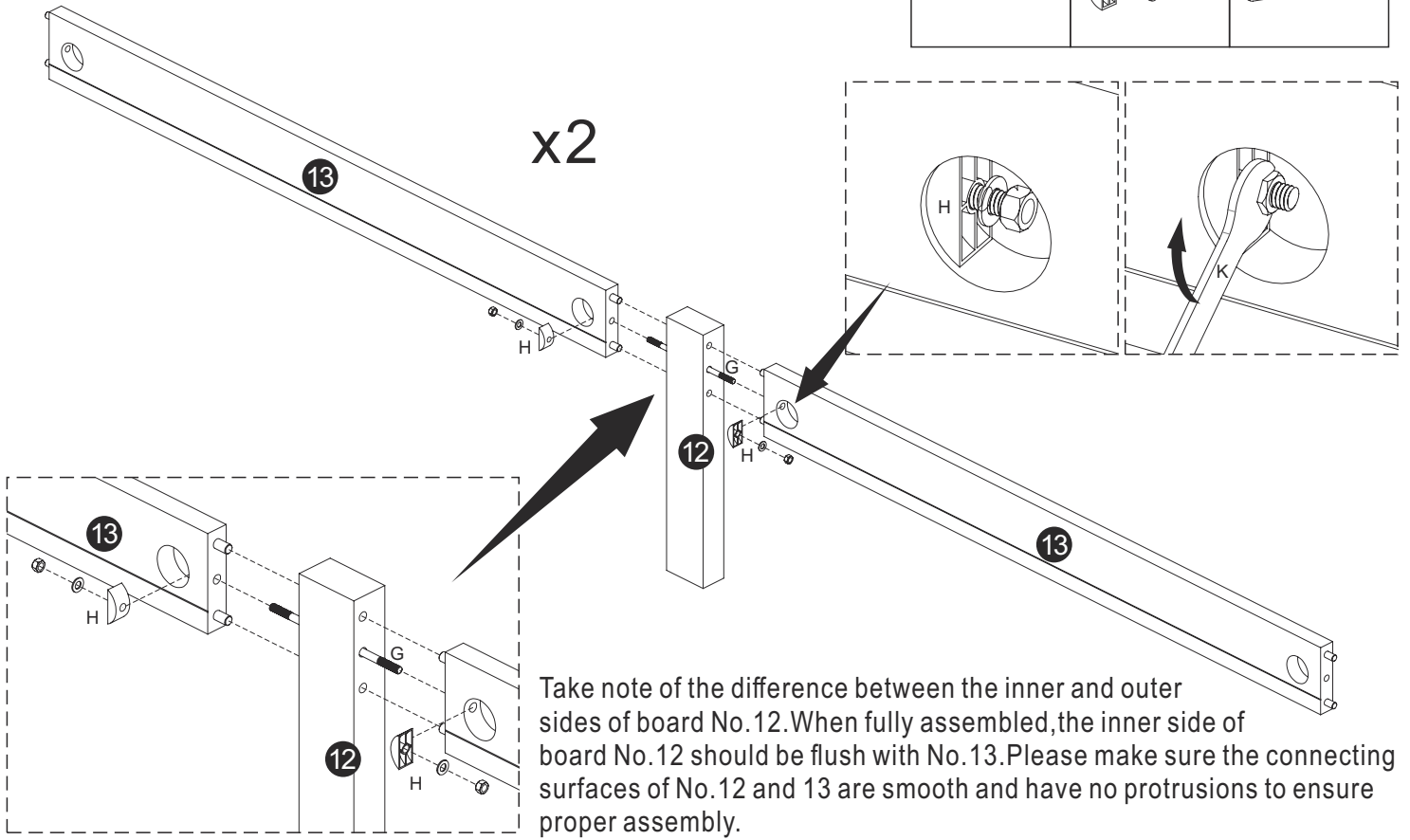
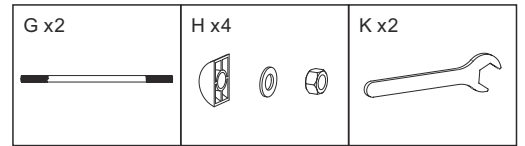

## Schritt 6

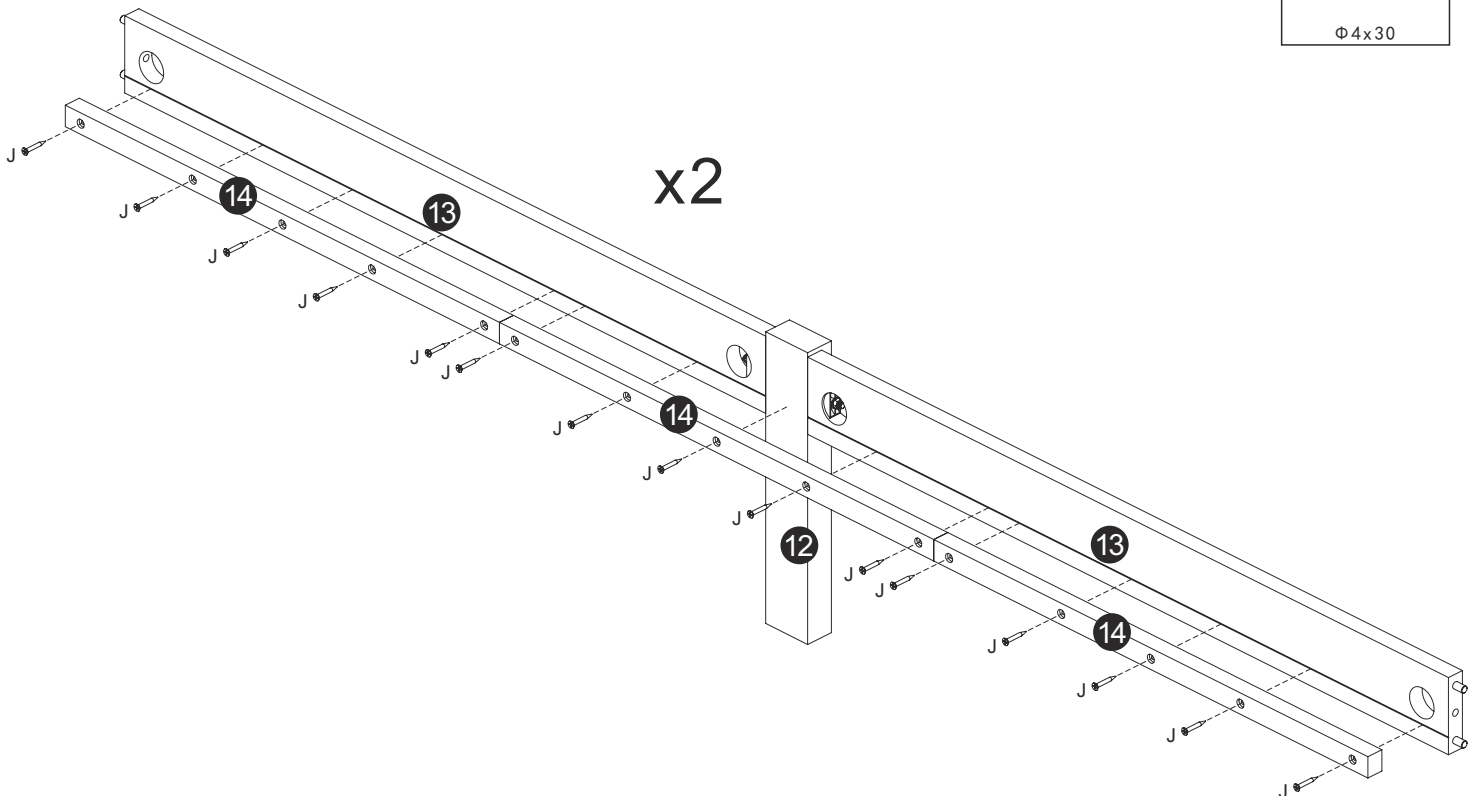
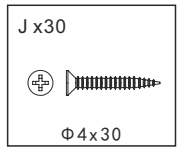

# Schritt 7





M x4

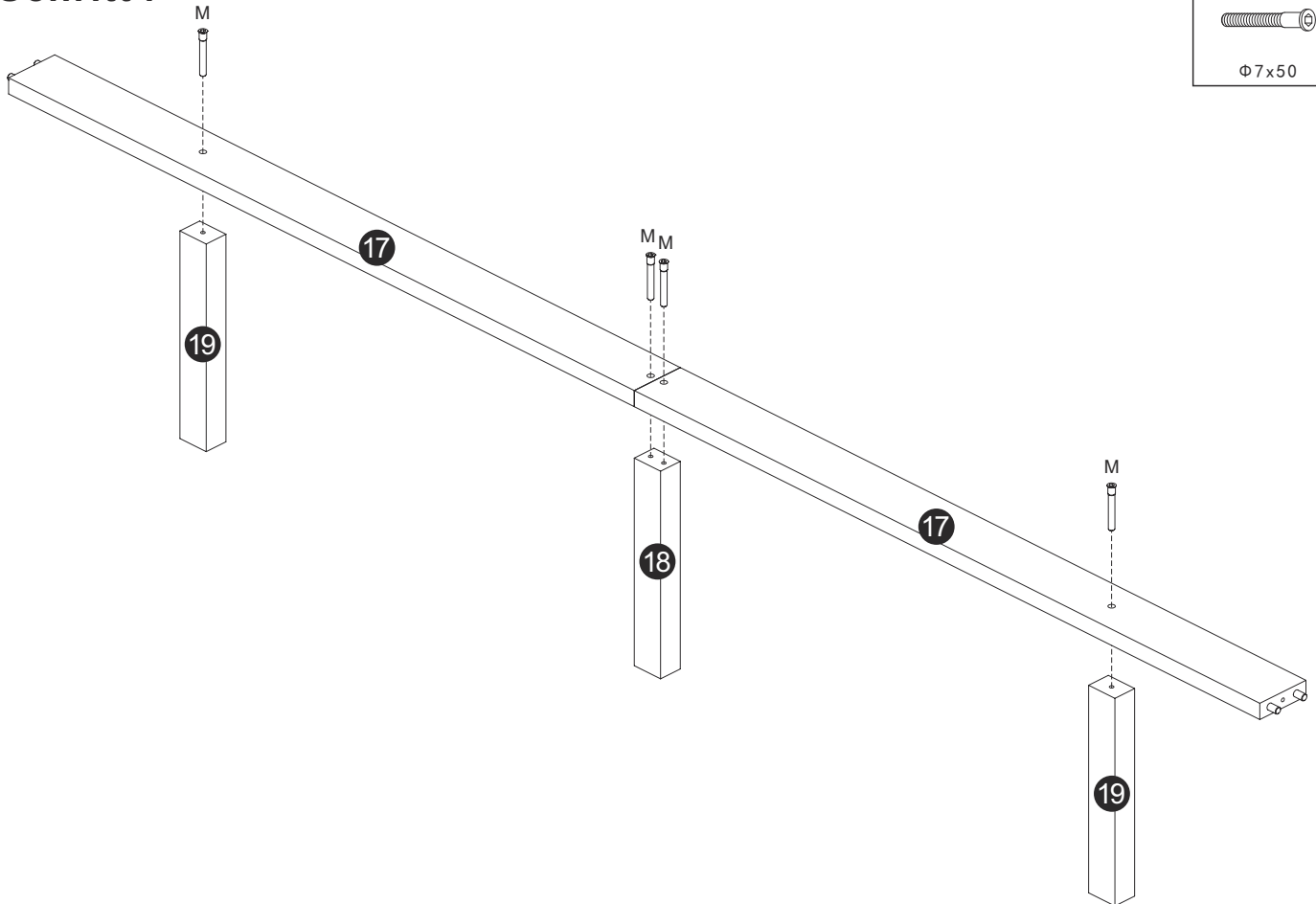

Φ7x50



# Schritt 8

F x4	H x4	K x1	N x2
			
M6x70			Φ6x70

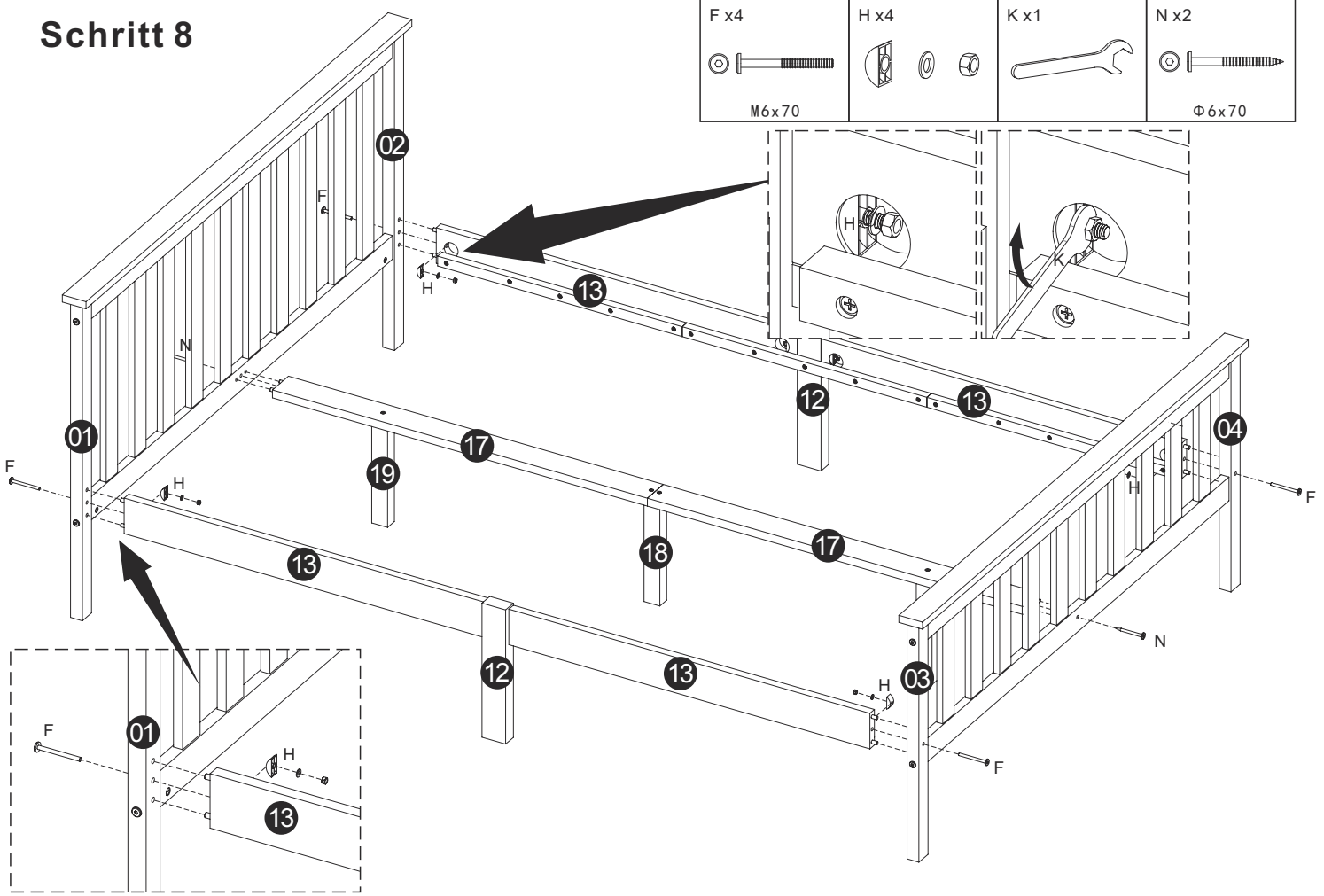

## Schritt 9

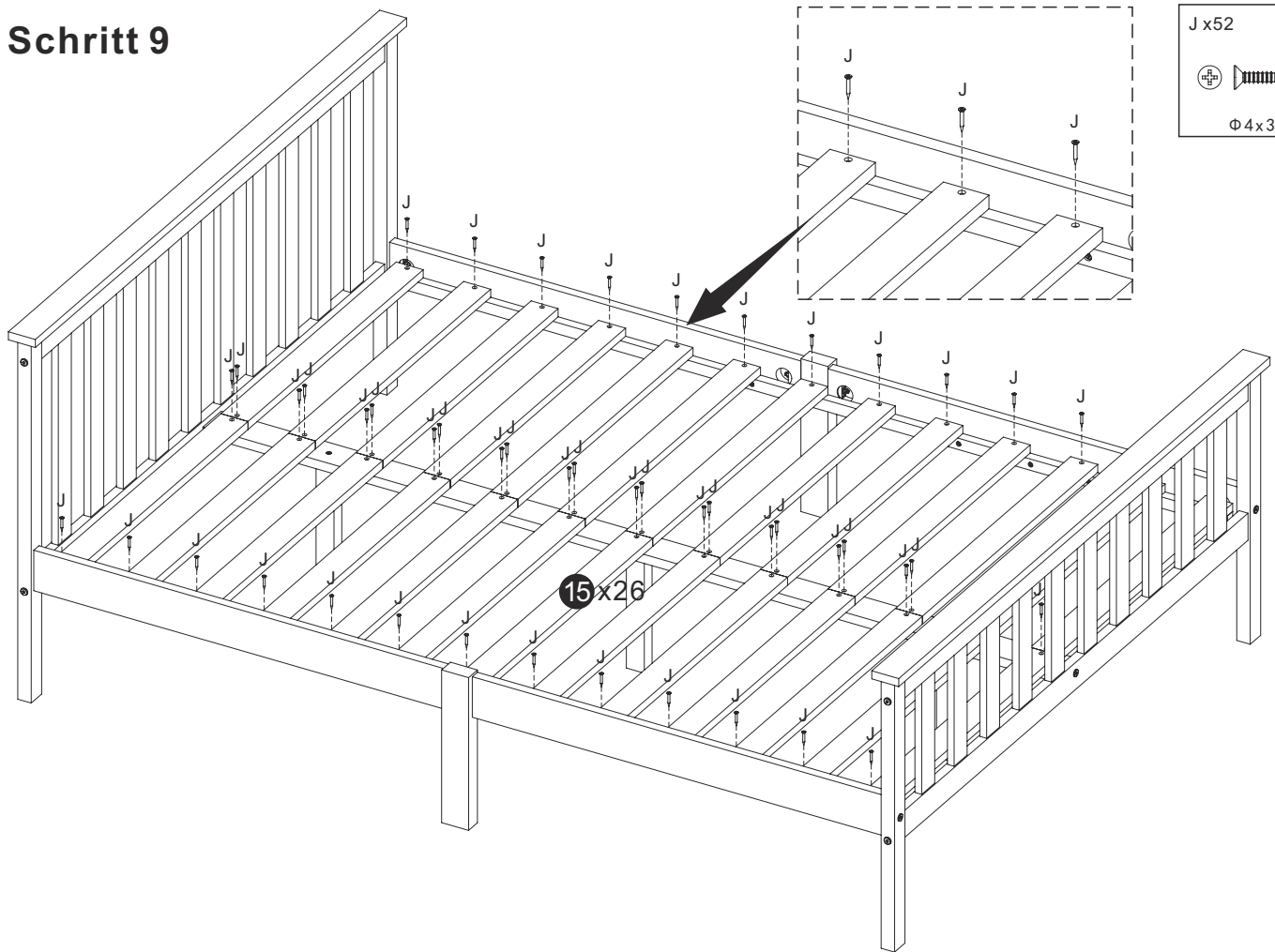

## Schritt 10

