

# MONTAGEANLEITUNGEN

## KINDERBETT

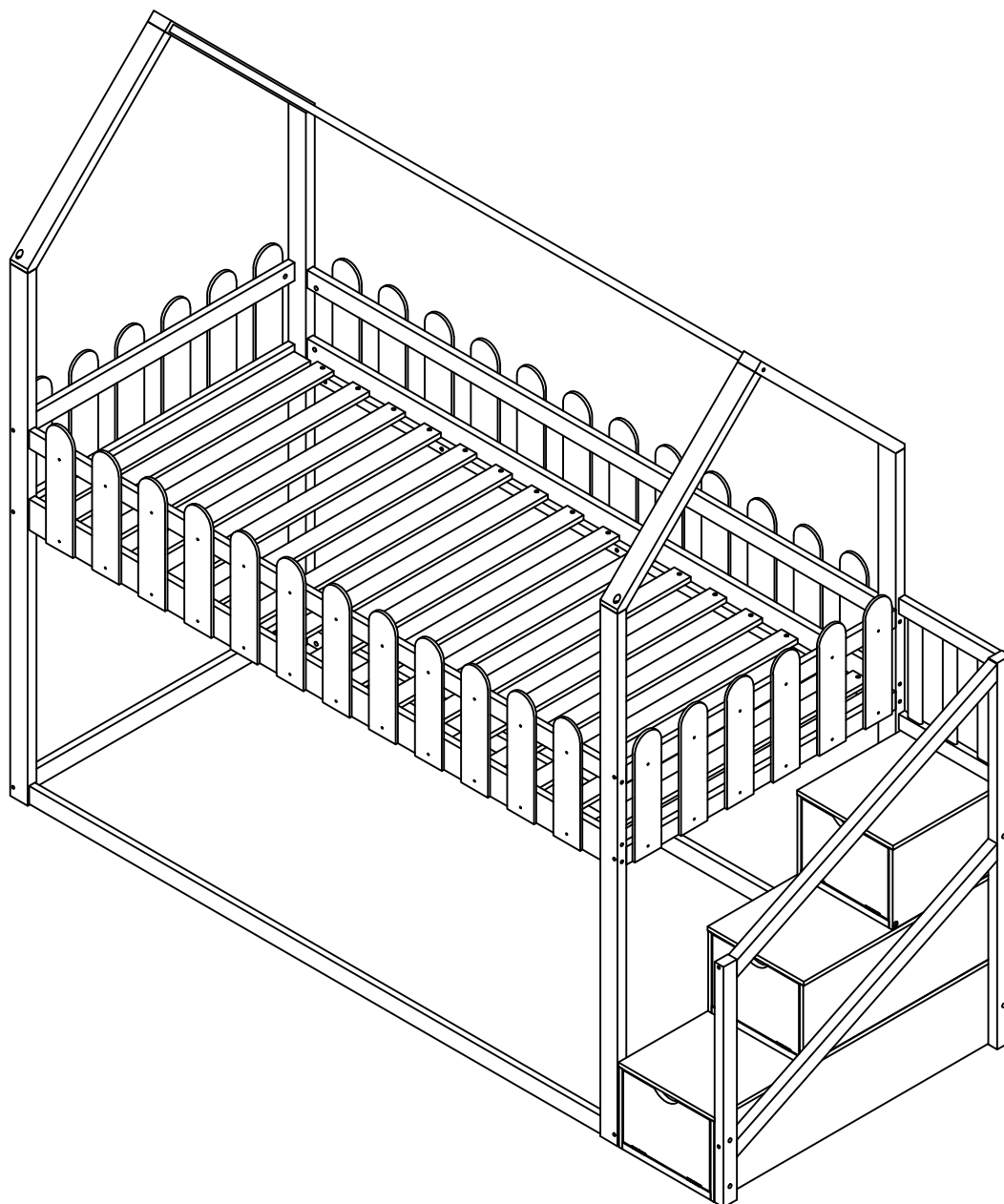

WF326039/WF326040/WF326041

# Montageanleitung

## WICHTIG! FÜR SPÄTERE BEZUGNAHME AUFBEWAHREN: SORGFÄLTIG LESEN

- Von einem Erwachsenen zu montieren. Die korrekte Montage muss vor Gebrauch von einem Erwachsenen geprüft werden
- Achtung! die Schrauben und kleinen Teile ausserhalb der Reichweite von Kindern lagern
- Vor Montagebeginn alle Teile identifizieren
- Ihren Artikel nicht benutzen, wenn eines seiner Bestandteile beschädigt ist oder fehlt
- Im Problemfall Ihren Kundendienst anrufen
- Stets die Herstelleranweisungen beachten
- Wartung: Mit einem weichen, trockenen Tuch reinigen. Bei größeren Flecken vorsichtig mit einem leicht feuchten, nicht scheuernden Schwamm abreiben
- Nicht auf dem Bett springen

---

## WICHTIG - SORGFÄLTIG LESEN - FÜR SPÄTERE BEZUGNAHME AUFBEWAHREN

- EN 747-1&2:2012+A1:2015
- **WARNHINWEIS:** Hochbetten und das obere Bett von Stockbetten sind aufgrund der Gefahr sturzbedingter Verletzungen für Kinder unter sechs Jahren nicht geeignet
- **WARNHINWEIS:** Bei unsachgemäßem Gebrauch kann bei Stockbetten und Hochbetten ernsthafte Gefahr von Verletzungen durch Strangulieren bestehen. An Stockbetten dürfen niemals Gegenstände befestigt oder aufgehängt werden, die nicht zur Verwendung mit dem betreffenden Bett bestimmt sind. Zu solchen Gegenständen zählen unter anderem Schnüre, Fäden, Bänder, Haken, Gürtel oder Taschen
- **WARNHINWEIS:** Kinder können zwischen dem Bett und einer Wand, einer Dachschräge, der Zimmerdecke, angrenzender Möbel (zum Beispiel Schränke) oder anderen Objekten eingeklemmt werden. Um der Gefahr schwerer Verletzungen vorzubeugen, darf der Abstand zwischen der oberen Absturzsicherung und den umgebenden Elementen 75 mm nicht überschreiten oder muss größer als 230mm sein
- **WARNHINWEIS:** Stockbett oder Hochbett nicht benutzen, wenn ein Teil des Aufbaus fehlt oder defekt ist
- Stets die Herstelleranweisungen beachten
- Das Zimmer muss ausreichend gelüftet werden, um die Luftfeuchtigkeit zu verringern und Schimmelbildung im Bett und rund um das Bett zu verhindern
- Alle Befestigungselemente müssen stets ordnungsgemäß festgezogen und regelmäßig überprüft und gegebenenfalls nachgezogen werden.
  
- Empfohlene Matratzengröße: 200 x 90cm
- Maximale dicke der matratze: 150mm
- Die Markierung am Produkt gibt die maximale Dicke der zu verwendenden Matratze an



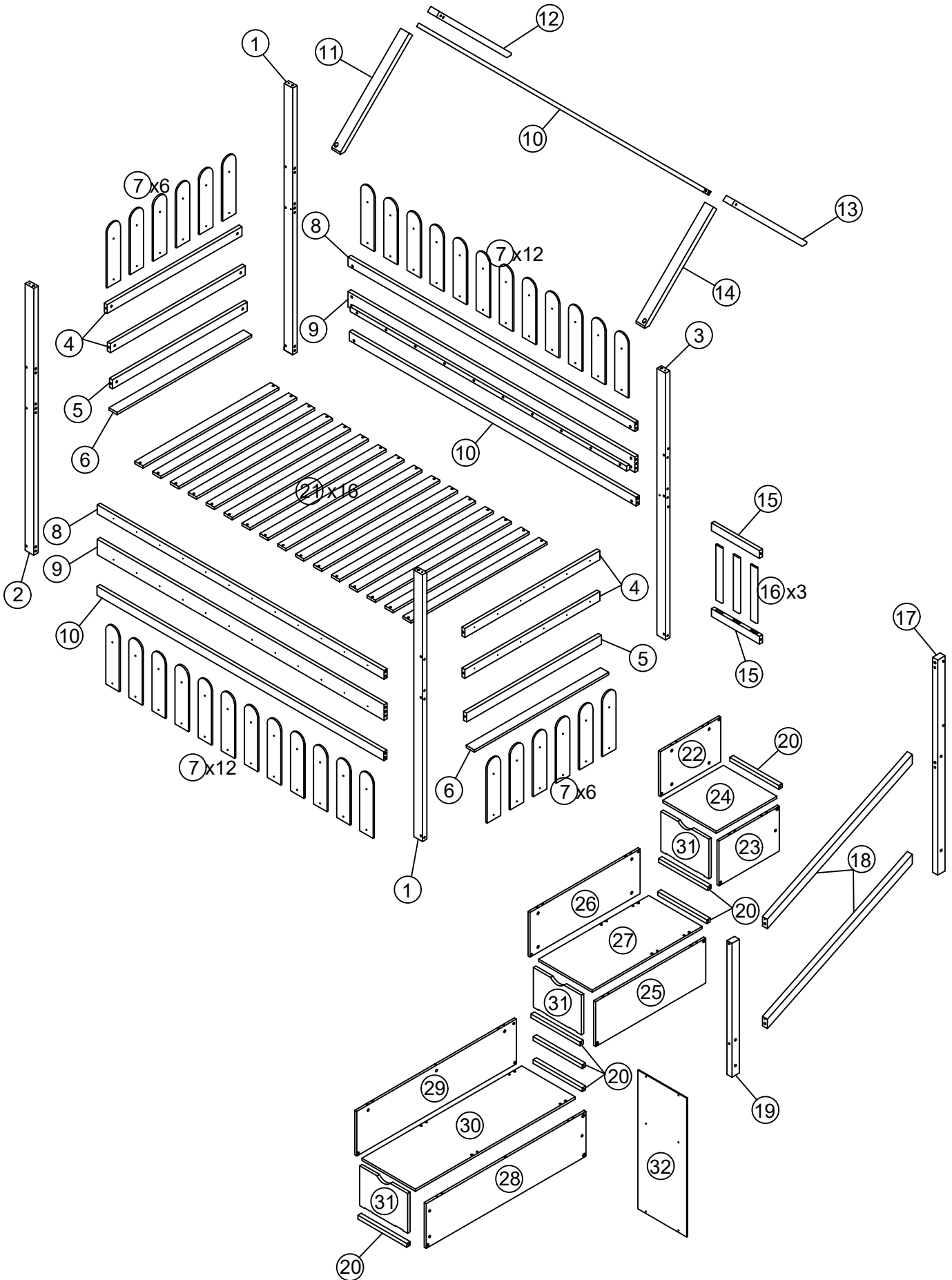



# MONTAGEANLEITUNGEN



# MONTAGEANLEITUNGEN

## TEILELIST

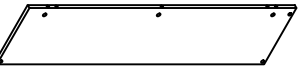
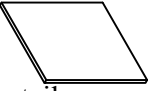
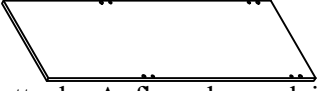
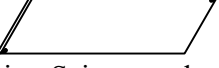

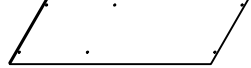



WF326039

<b>21</b>	 Latten	16pcs	<b>27</b>	 Aufbewahrungsleiter Zwischenwand	1pc
<b>22</b>	 Aufbewahrungsleiter Seitenwand	1pc	<b>28</b>	 Aufbewahrungsleiter Seitenwand	1pc
<b>23</b>	 Aufbewahrungsleiter Seitenwand	1pc	<b>29</b>	 Aufbewahrungsleiter Seitenwand	1pc
<b>24</b>	 Aufbewahrungsleiter Oberteil	1pc	<b>30</b>	 Bodenplatte der Aufbewahrungsleiter	1pc
<b>25</b>	 Aufbewahrungsleiter Seitenwand	1pc	<b>31</b>	 Schubladenfronten	3pcs
<b>26</b>	 Aufbewahrungsleiter Seitenwand	1pc	<b>32</b>	 Aufbewahrungsleiter Rückwand unten	1pc

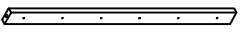
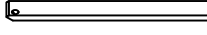
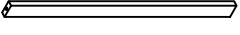

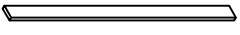

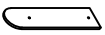
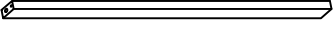
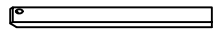
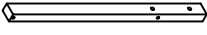
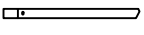
# MONTAGEANLEITUNGEN

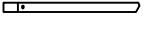
## TEILELIST

### WF326040 (Hardware-in dieser SKU)

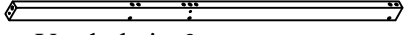

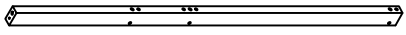
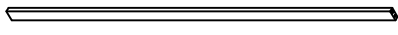
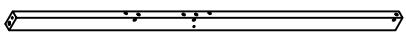

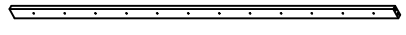











<b>4</b>	 Stange am Kopfteilrahmen	4pcs	<b>14</b>	 Dach - vordere Stütze	1pc
<b>5</b>	 Stange am Kopfteilrahmen	2pcs	<b>15</b>	 Aufbewahrungsleiterstütze	2pcs
<b>6</b>	 Beinstütze	2pcs	<b>16</b>	 Betrahmen Stange	3pcs
<b>7</b>	 Betrahmen Stange	36pcs	<b>18</b>	 Aufbewahrungsleiterstütze	2pcs
<b>11</b>	 Dach - vordere Stütze	1pc	<b>19</b>	 Aufbewahrungsleiterstütze	1pc
<b>12</b>	 Dach - vordere Stütze	1pc	<b>20</b>	 Aufbewahrungsleiterstütze	7pcs
<b>13</b>	 Dach - vordere Stütze	1pc			

### WF326041

<b>1</b>	 Linkes Vorderbein & Rechtes Hinterbein	2pcs	<b>9</b>	 Hinterer Seitenholm	2pcs
<b>2</b>	 Linkes Vorderbein	1pc	<b>10</b>	 Stange am hinteren Balustradenrahmen	3pcs
<b>3</b>	 Rechtes Hinterbein	1pc	<b>17</b>	 Aufbewahrungsleiterstütze	1pc
<b>8</b>	 Stange am hinteren Balustradenrahmen	2pcs			

# MONTAGEANLEITUNGEN

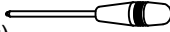

## HARDWARE-LISTE (WF326040)

<b>A</b>	Ø0.4x3		32PCS	<b>J</b>	Ø1x4		24PCS
<b>B</b>	Ø0.35x1.2		34PCS	<b>K</b>	Ø0.8x3		20PCS
<b>C</b>	Ø0.4x2		72PCS	<b>L</b>	Ø 0.65x3.5		22PCS
<b>D</b>	0.63x10		20PCS	<b>M</b>	Ø1.2x1		22PCS
<b>E</b>	0.63x7.5		14PCS	<b>N</b>	0.63x3.5		4PCS
<b>F</b>	0.65x9		4PCS	<b>O</b>	4.4x1.7x1.4		3PCS
<b>G</b>	0.65x6		6PCS	<b>P</b>	1.5x1.5x0.2		5PCS
<b>H</b>	0.65x5		14PCS	Benötigte Werkzeuge (nicht von uns gestellt)			
<b>I</b>	0.4x5.8		1PC				

# MONTAGEANLEITUNGEN

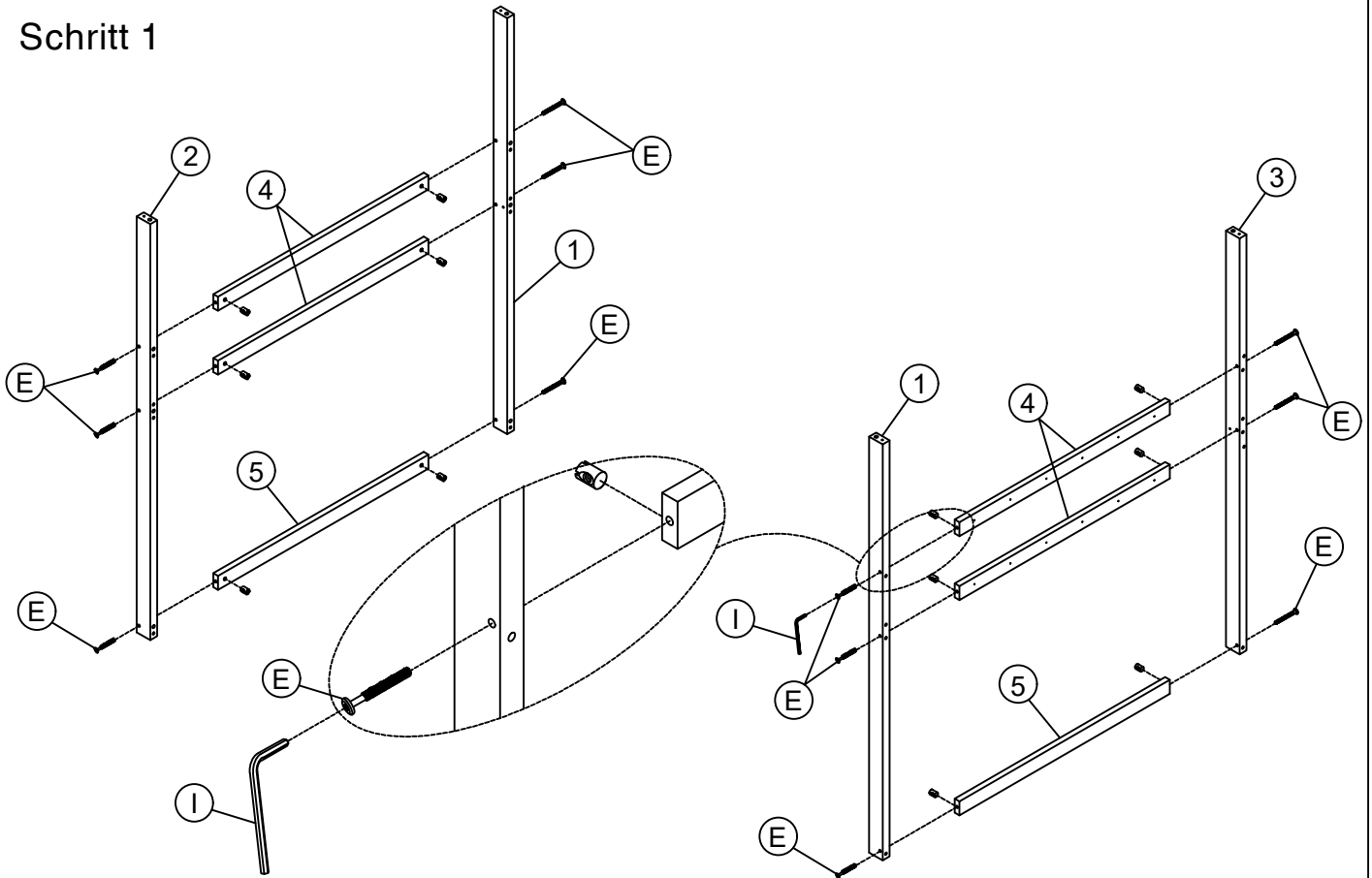

## Schritt 1

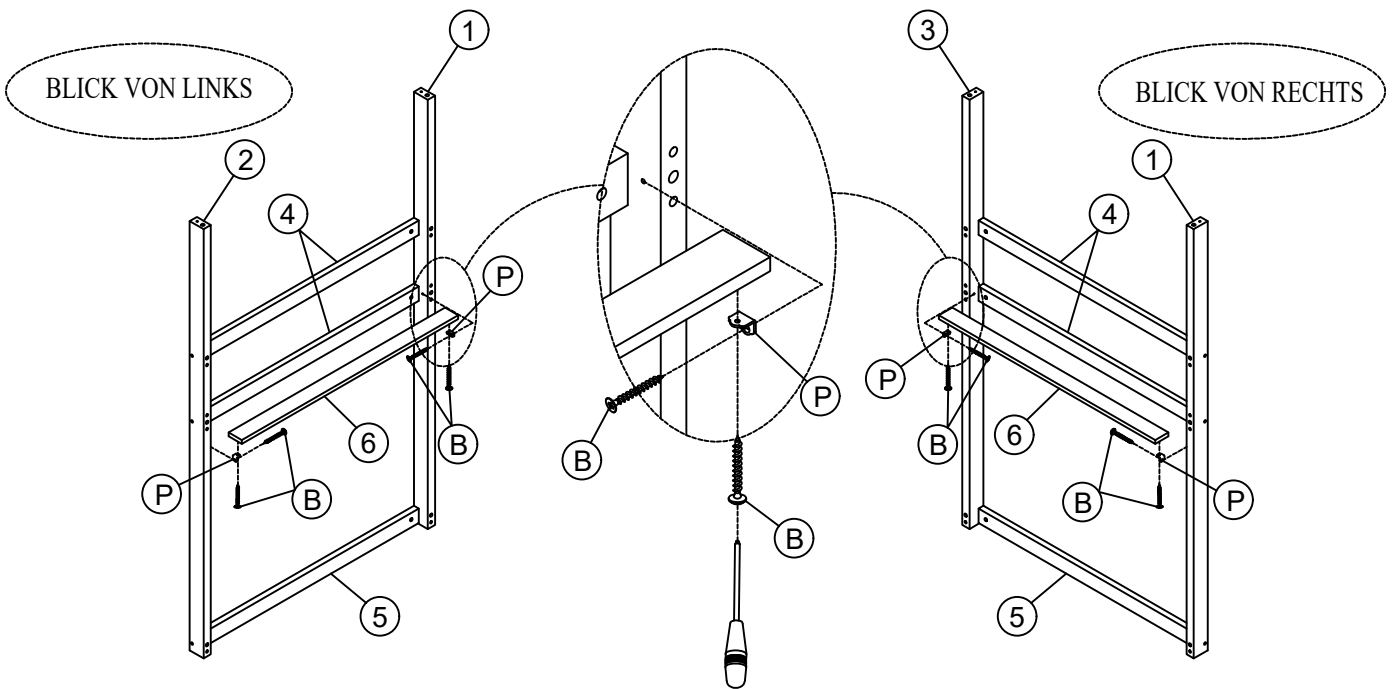

<b>E</b>	0.63x7.5 	12PCS	<b>I</b>	0.4x5.8 	1PC
----------	--	-------	----------	---	-----

## Schritt 2





<b>P</b>	1.5x1.5x0.2 	4PCS	<b>B</b>	Ø0.35x1.2 	8PCS
----------	---	------	----------	---	------

# MONTAGEANLEITUNGEN

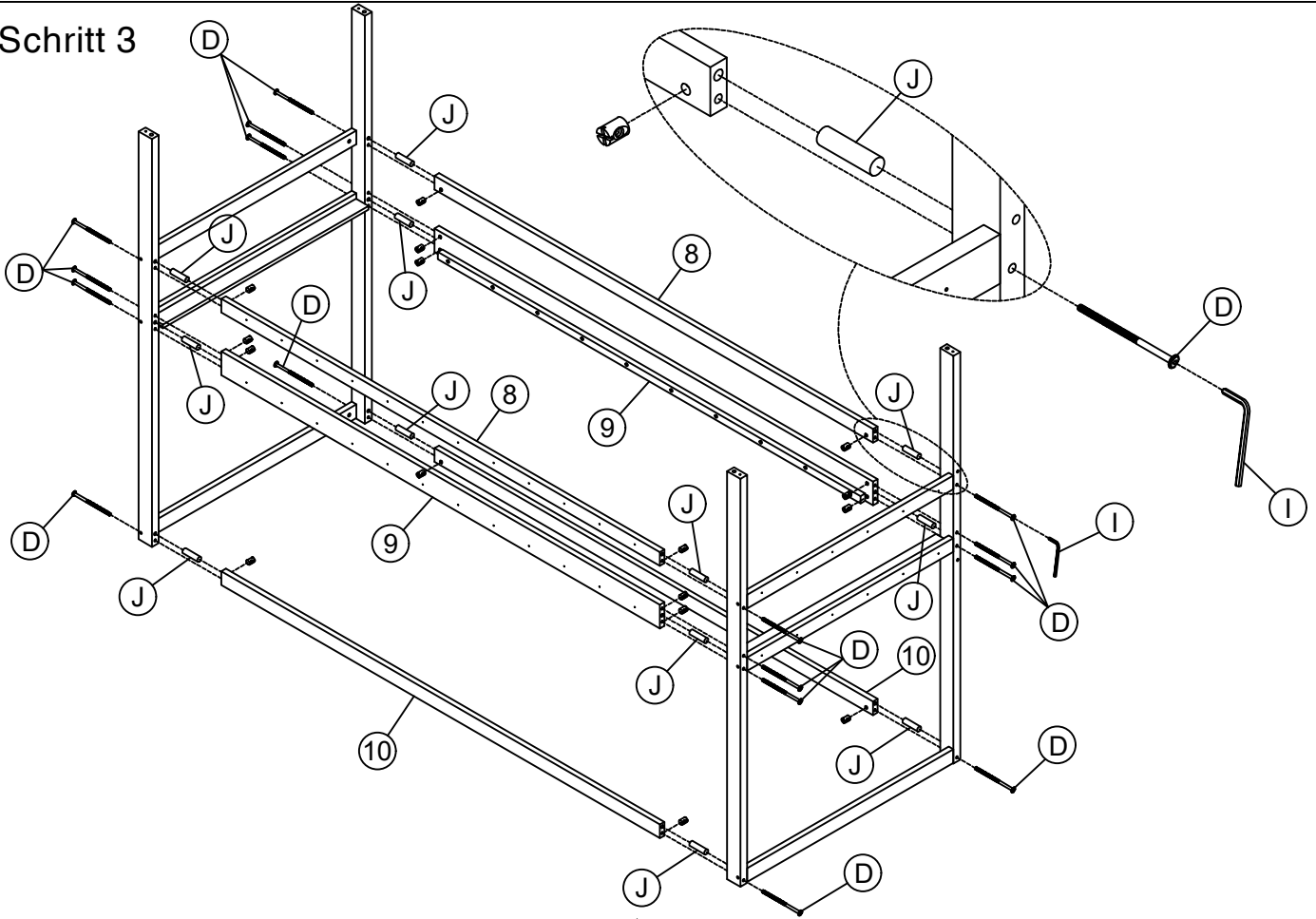

## Schritt 3

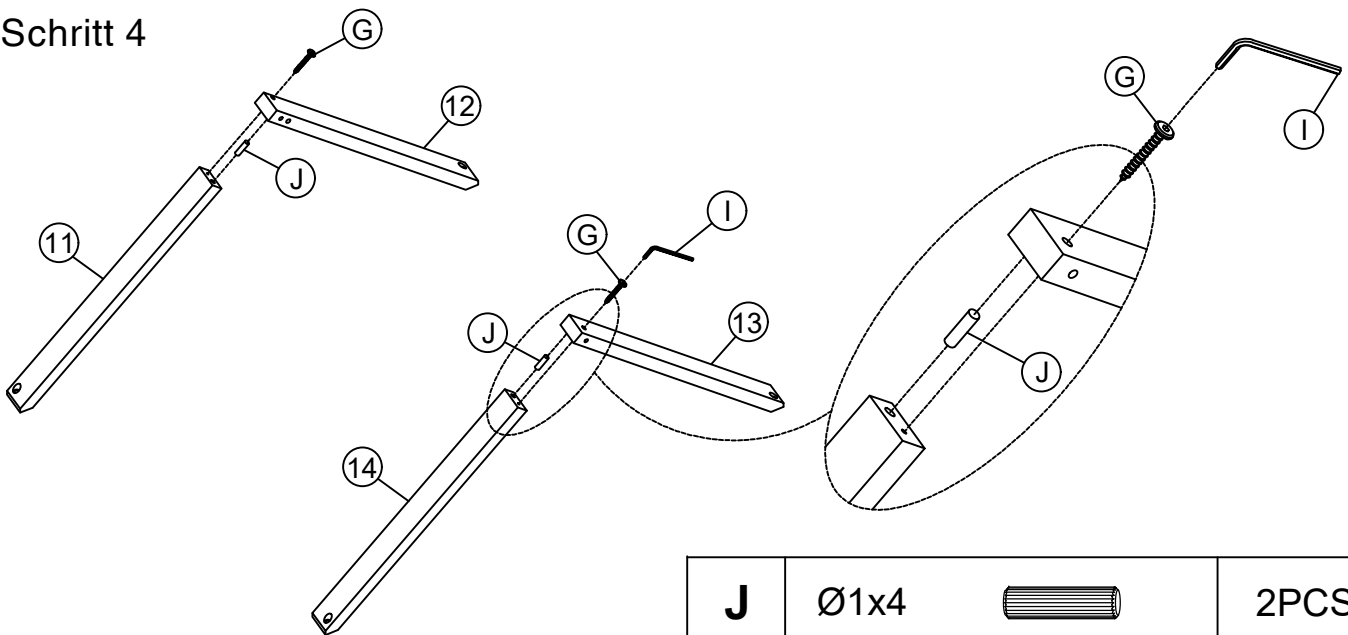

<b>I</b>	0.4x5.8		1PC	<b>J</b>	Ø1x4		12PCS
<b>D</b>	0.63x10		16PCS				

## Schritt 4







<b>G</b>	0.65x6		2PCS	<b>J</b>	Ø1x4		2PCS
<b>I</b>	0.4x5.8		1PC				

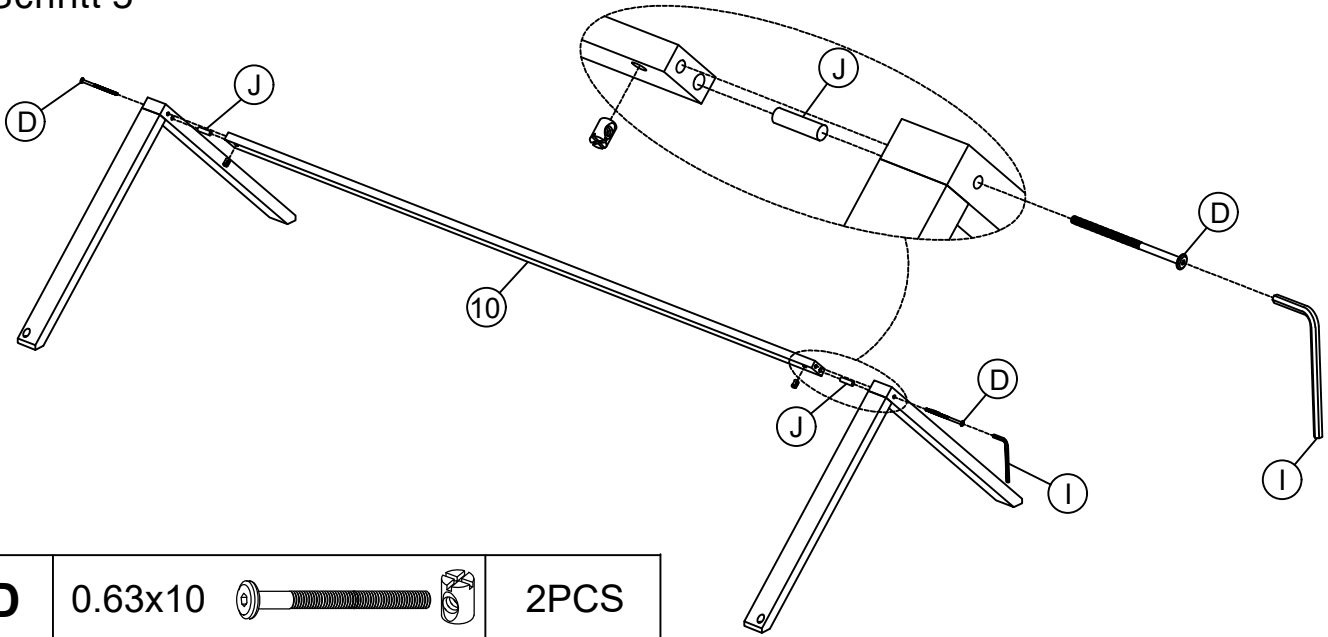

# MONTAGEANLEITUNGEN



## Schritt 5

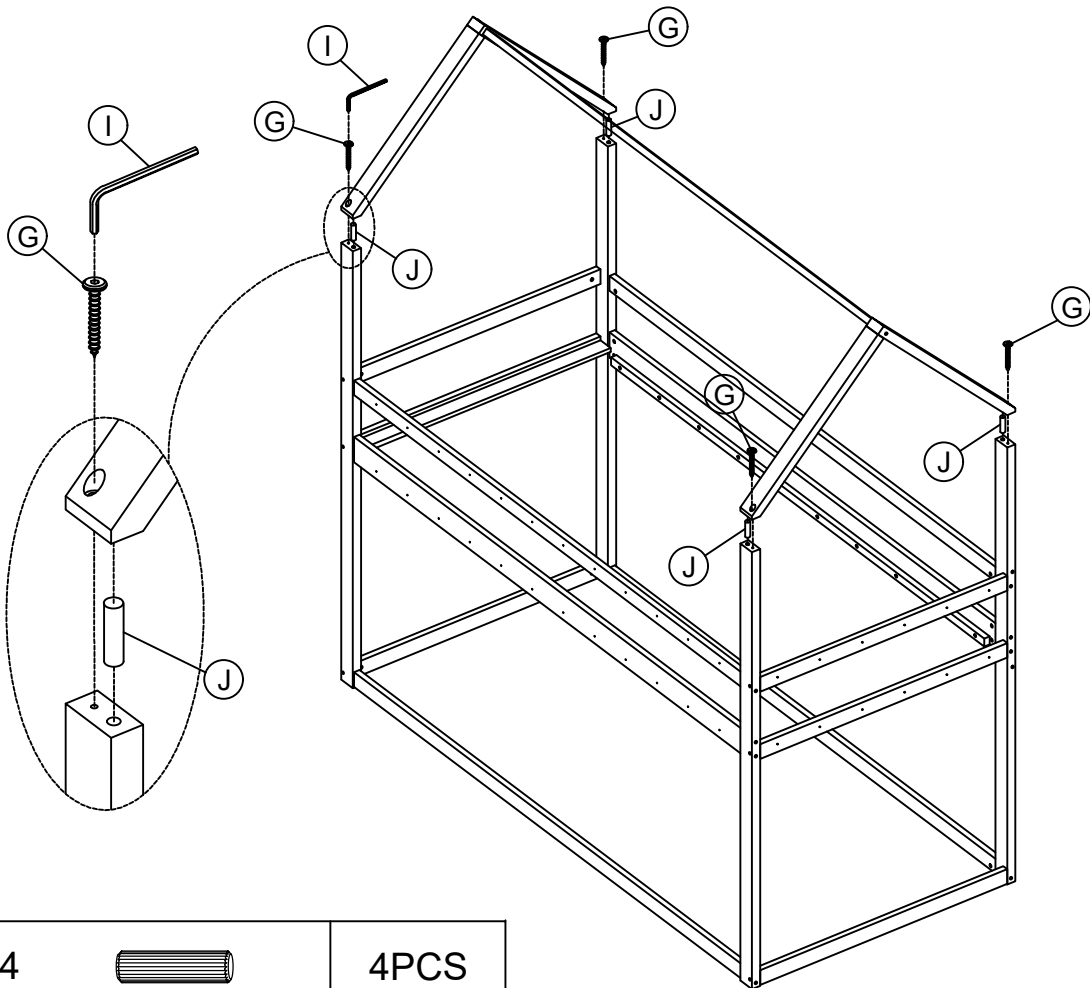

<b>D</b>	0.63x10		2PCS				
<b>J</b>	Ø1x4		2PCS	<b>I</b>	0.4x5.8		1PC

## Schritt 6



<b>J</b>	Ø1x4		4PCS				
<b>G</b>	0.65x6		4PCS	<b>I</b>	0.4x5.8		1PC

# MONTAGEANLEITUNGEN

## Schritt 7

Befestigen Sie zunächst 2 Stück von Teil 21 an der Vorderseite und am Ende des Rahmens zwischen dem Kopfteil.

Dann befestigen Sie das restliche Teil 21 gleichmäßig zwischen dem Kopfteil.

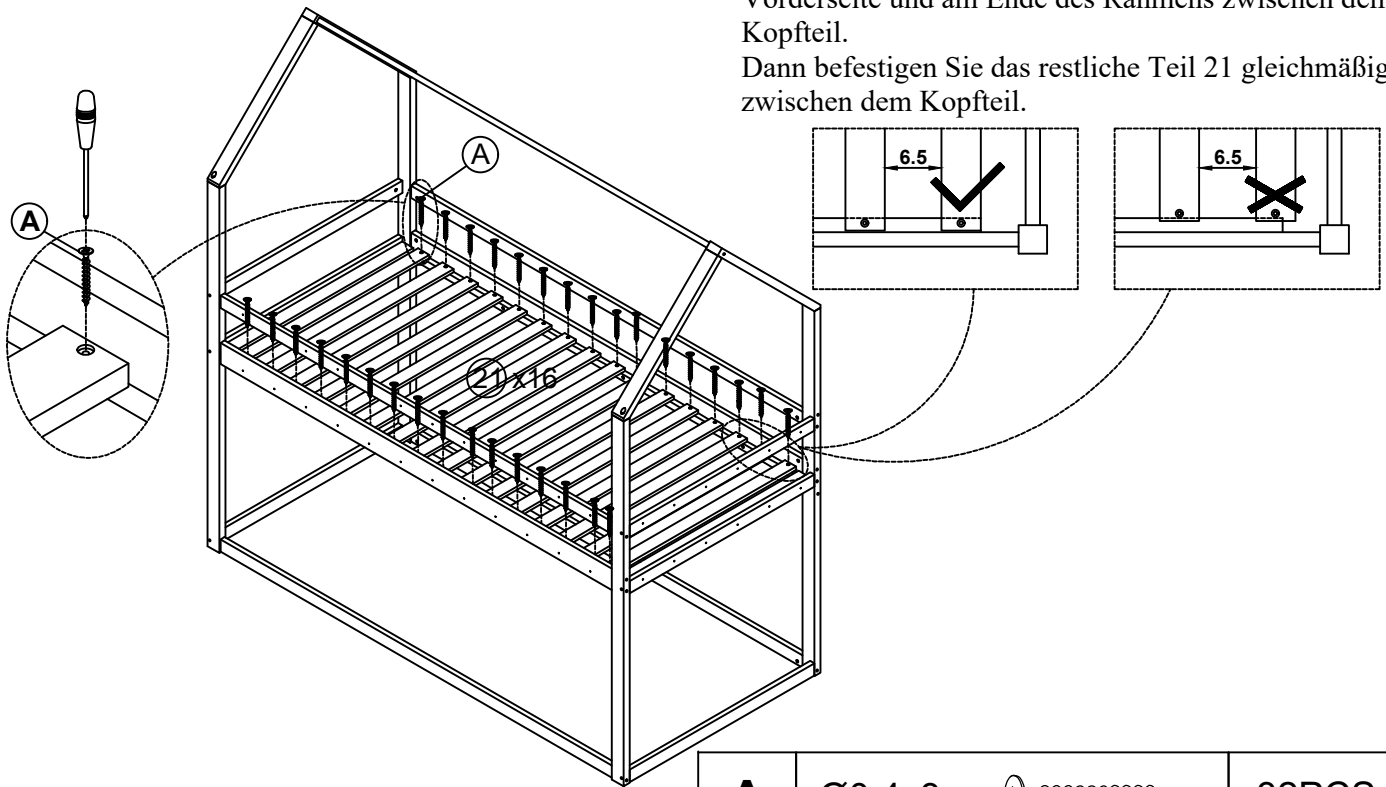

**A**

Ø0.4x3



32PCS

## Schritt 8

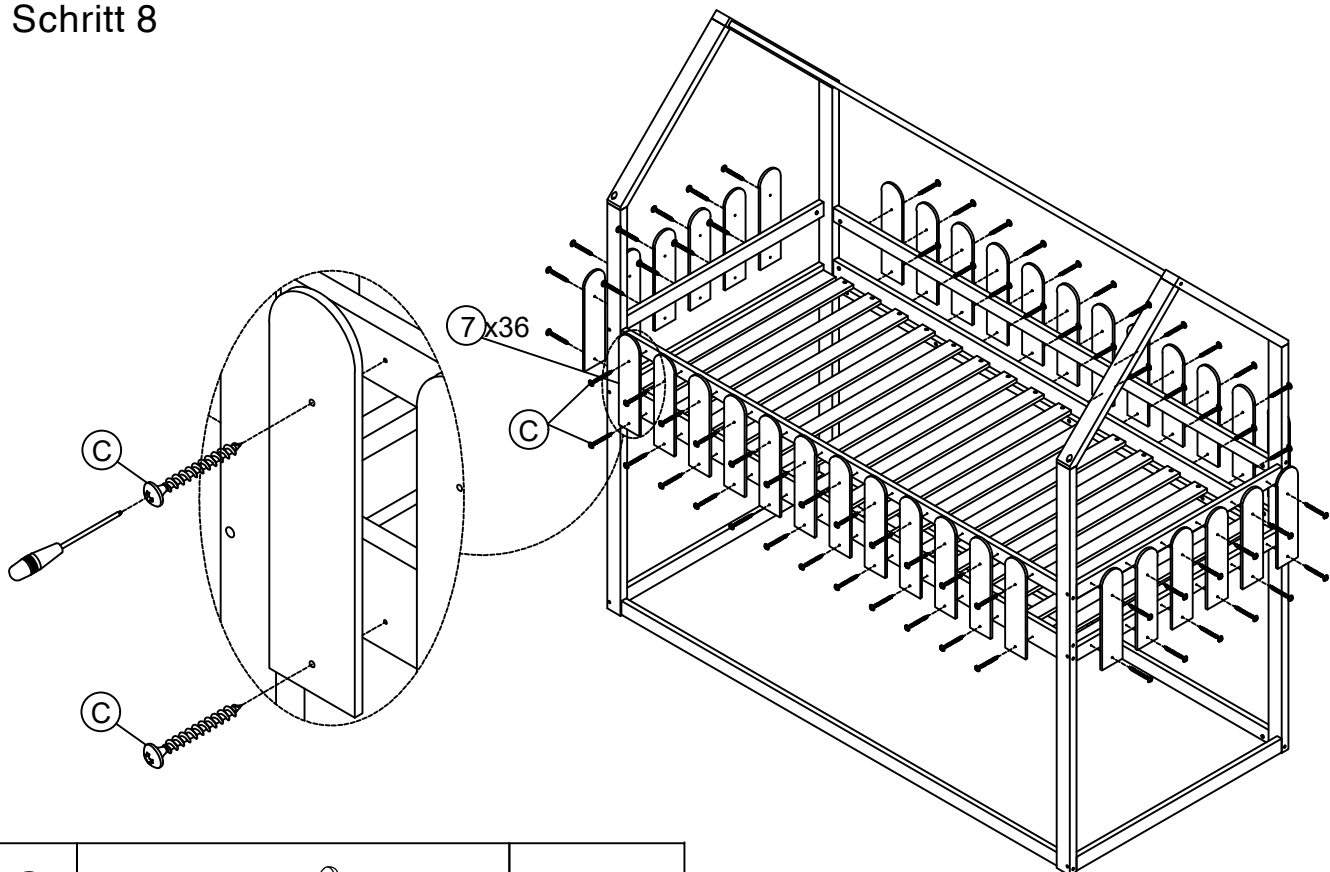

**C**

Ø0.4x2



72PCS

# MONTAGEANLEITUNGEN

## Schritt 9

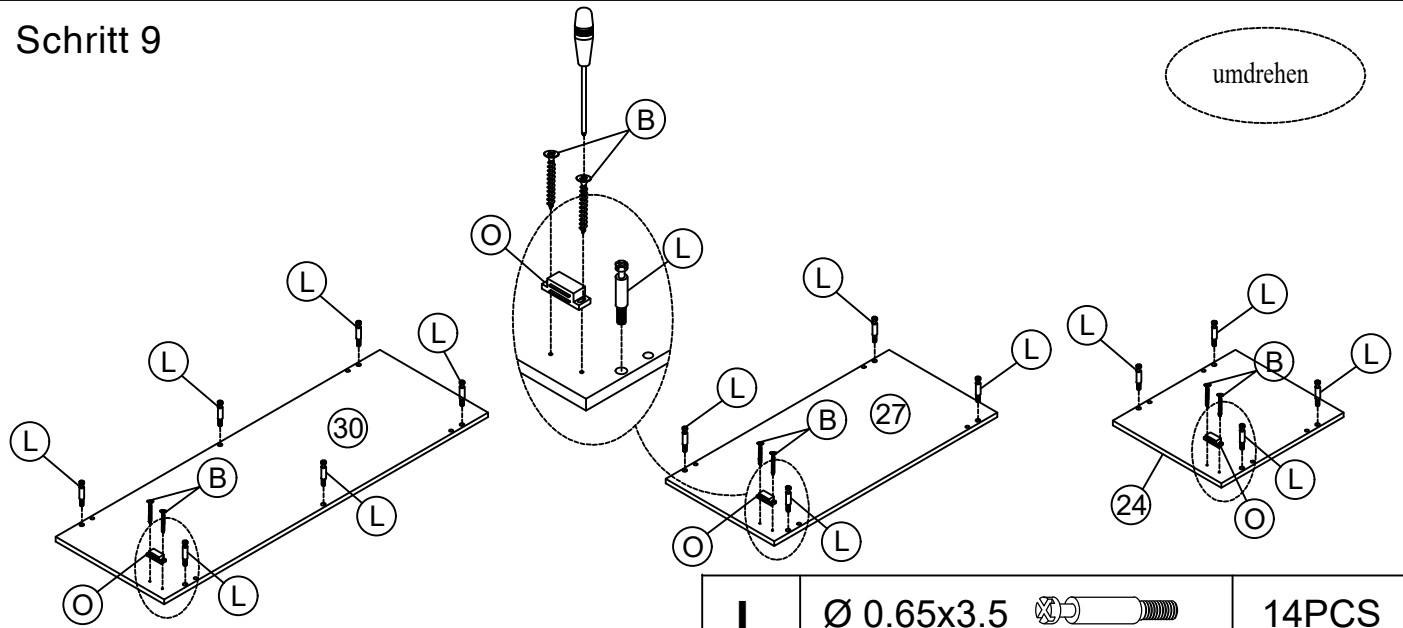

<b>L</b>	Ø 0.65x3.5		14PCS
<b>O</b>	4.4x1.7x1.4		3PCS
<b>B</b>	Ø0.35x1.2		6PCS

## Schritt 10

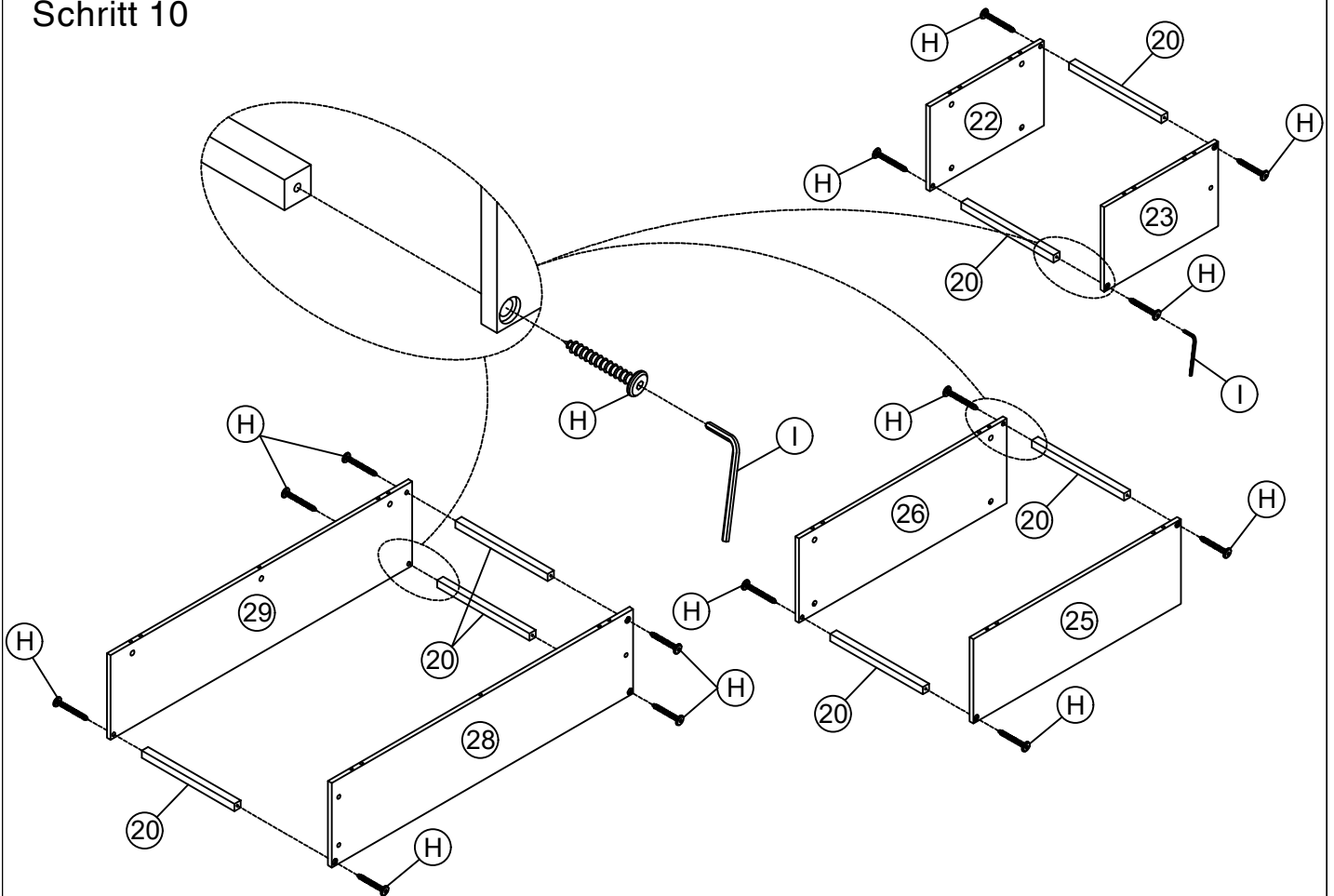



<b>H</b>	0.65x5		14PCS	<b>I</b>	0.4x5.8		1PC
----------	--------	--	-------	----------	---------	--	-----

# MONTAGEANLEITUNGEN

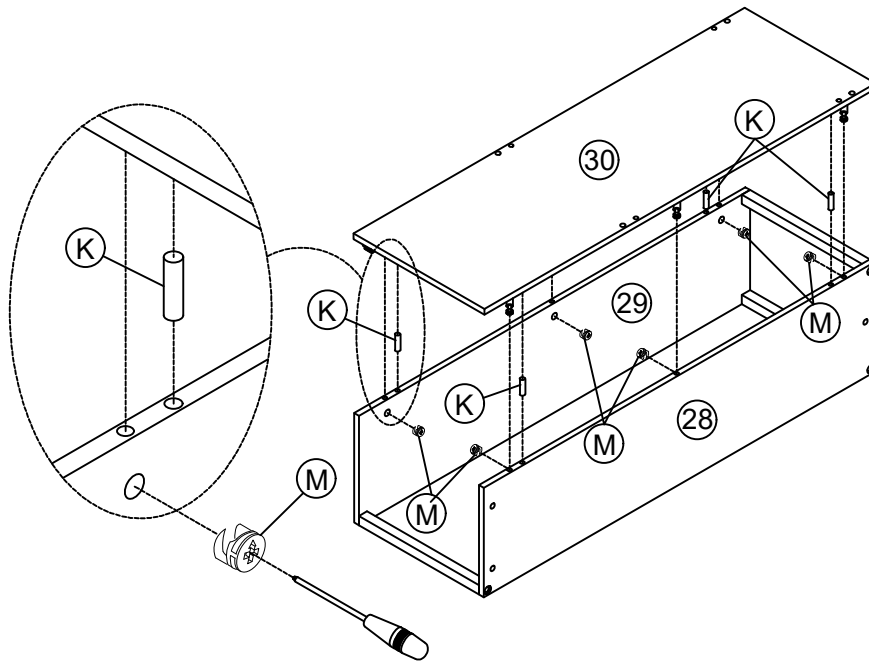
## Schritt 11



<b>K</b>	Ø0.8x3		4PCS	<b>M</b>	Ø1.2x1		6PCS
----------	--------	---	------	----------	--------	---	------

## Schritt 12

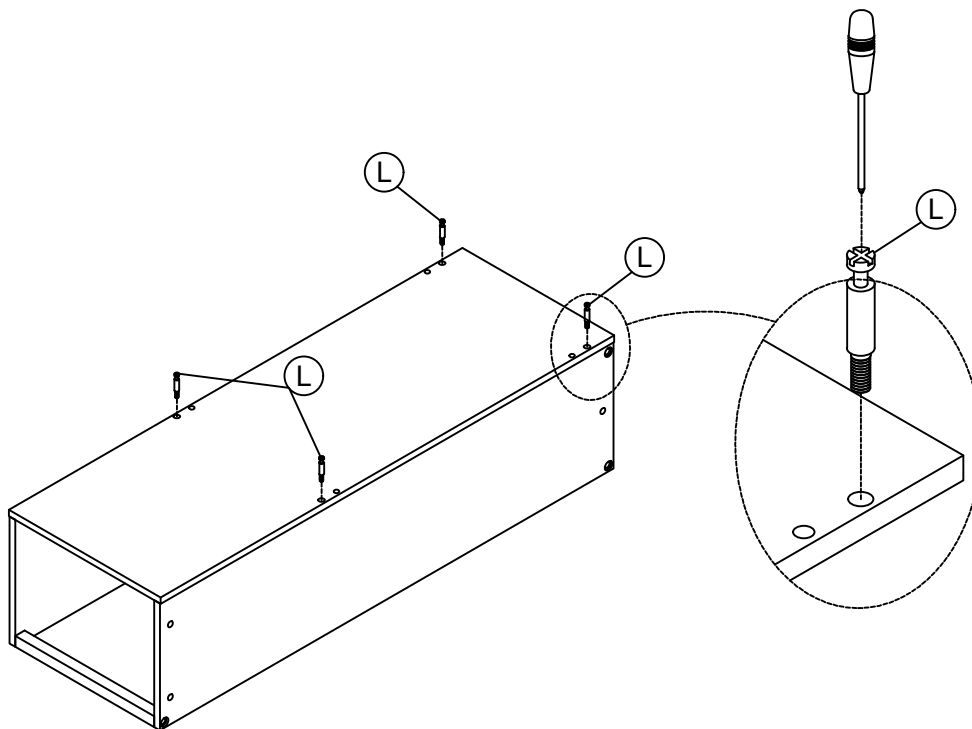



<b>L</b>	Ø 0.65x3.5		4PCS
----------	------------	---	------

# MONTAGEANLEITUNGEN

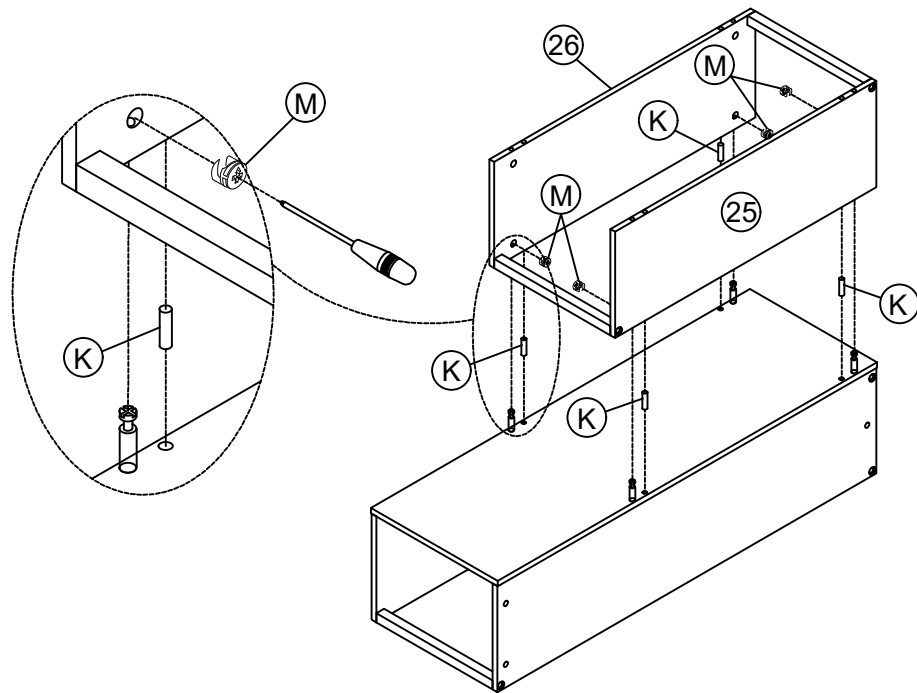

## Schritt 13

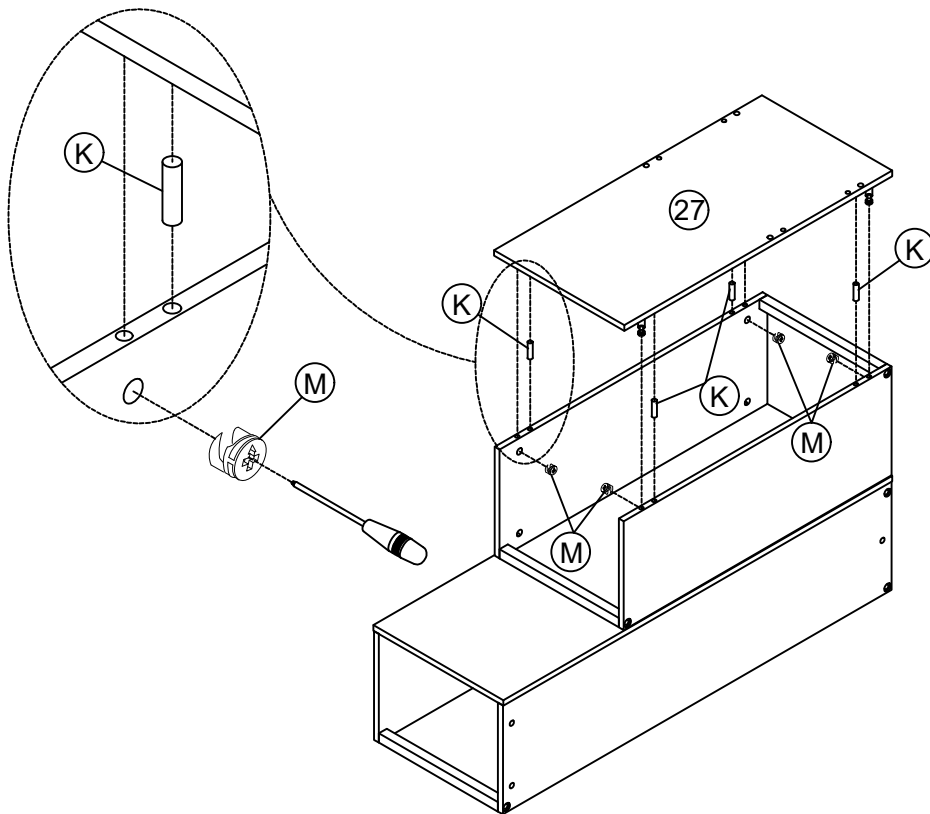

<b>M</b>	Ø1.2x1		4PCS	<b>K</b>	Ø0.8x3		4PCS
----------	--------	--	------	----------	--------	--	------

## Schritt 14



<b>M</b>	Ø1.2x1		4PCS	<b>K</b>	Ø0.8x3		4PCS
----------	--------	---	------	----------	--------	---	------

# MONTAGEANLEITUNGEN

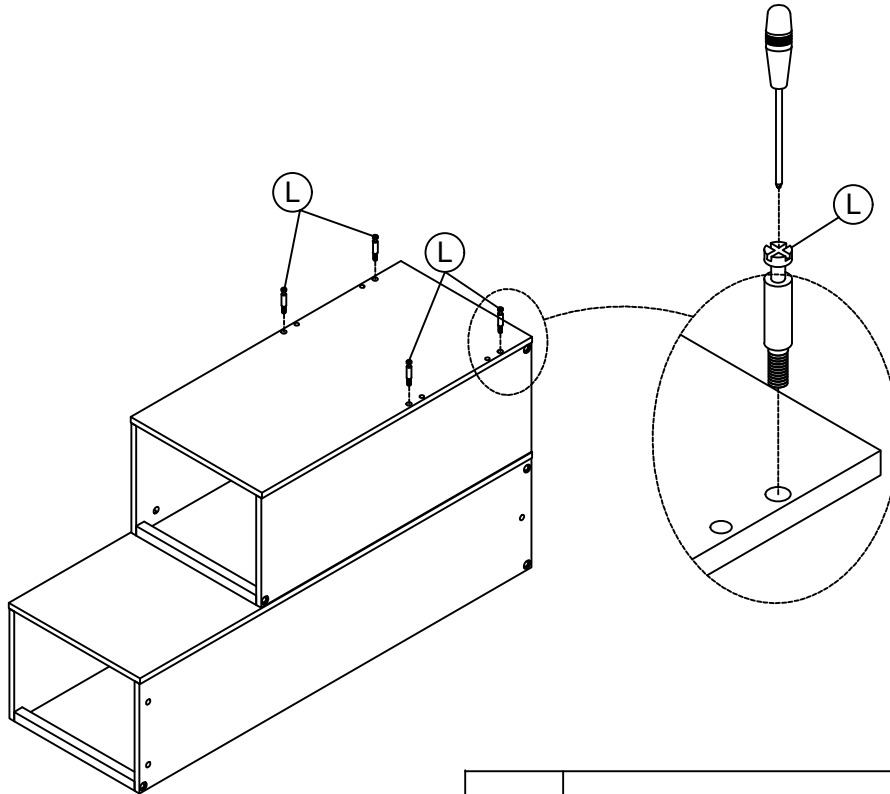

## Schritt 15

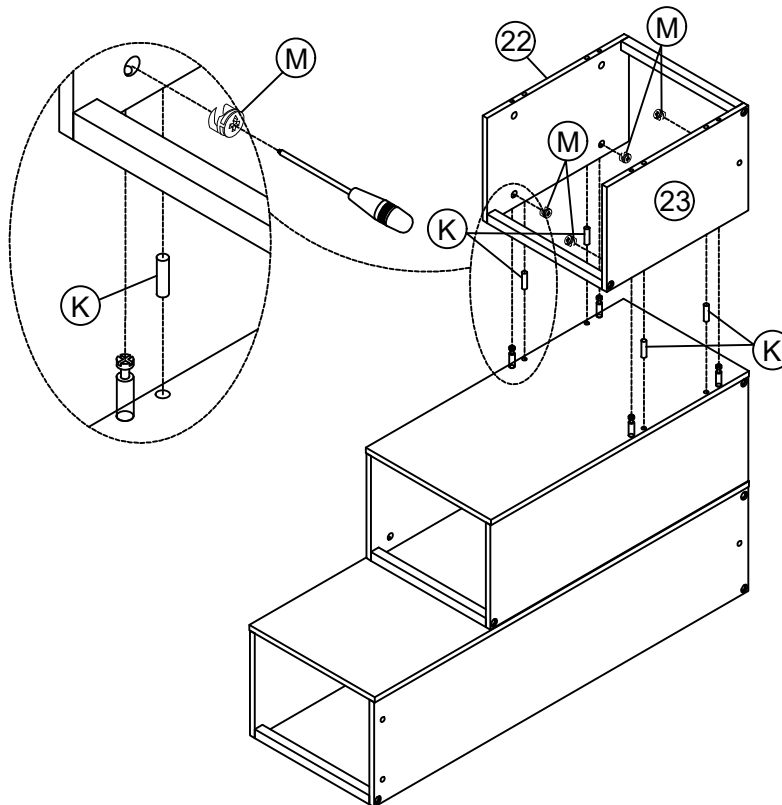

<b>L</b>	Ø 0.65x3.5		4PCS
----------	------------	--	------

## Schritt 16





<b>M</b>	Ø1.2x1		4PCS	<b>K</b>	Ø0.8x3		4PCS
----------	--------	---	------	----------	--------	---	------

# MONTAGEANLEITUNGEN

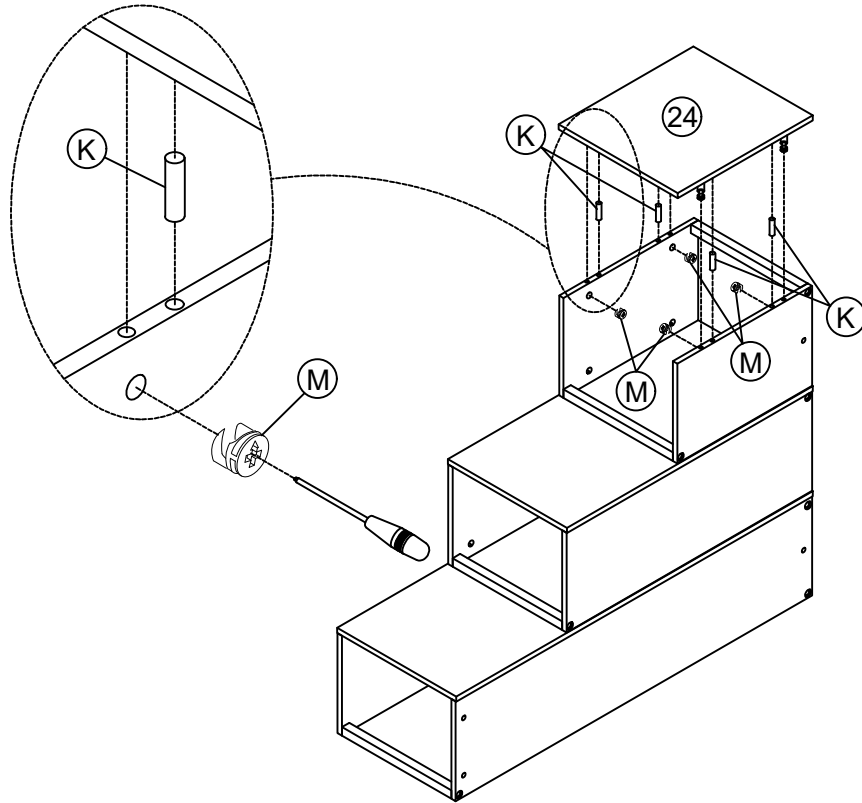
## Schritt 17



<b>M</b>	Ø1.2x1		4PCS	<b>K</b>	Ø0.8x3		4PCS
----------	--------	---	------	----------	--------	---	------

## Schritt 18

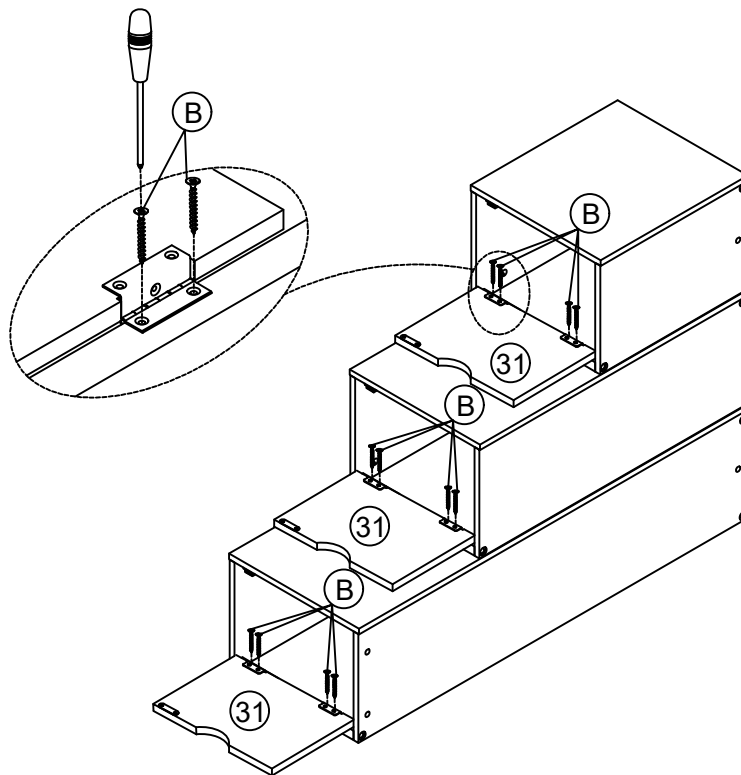



<b>B</b>	Ø0.35x1.2		12PCS
----------	-----------	---	-------

# MONTAGEANLEITUNGEN

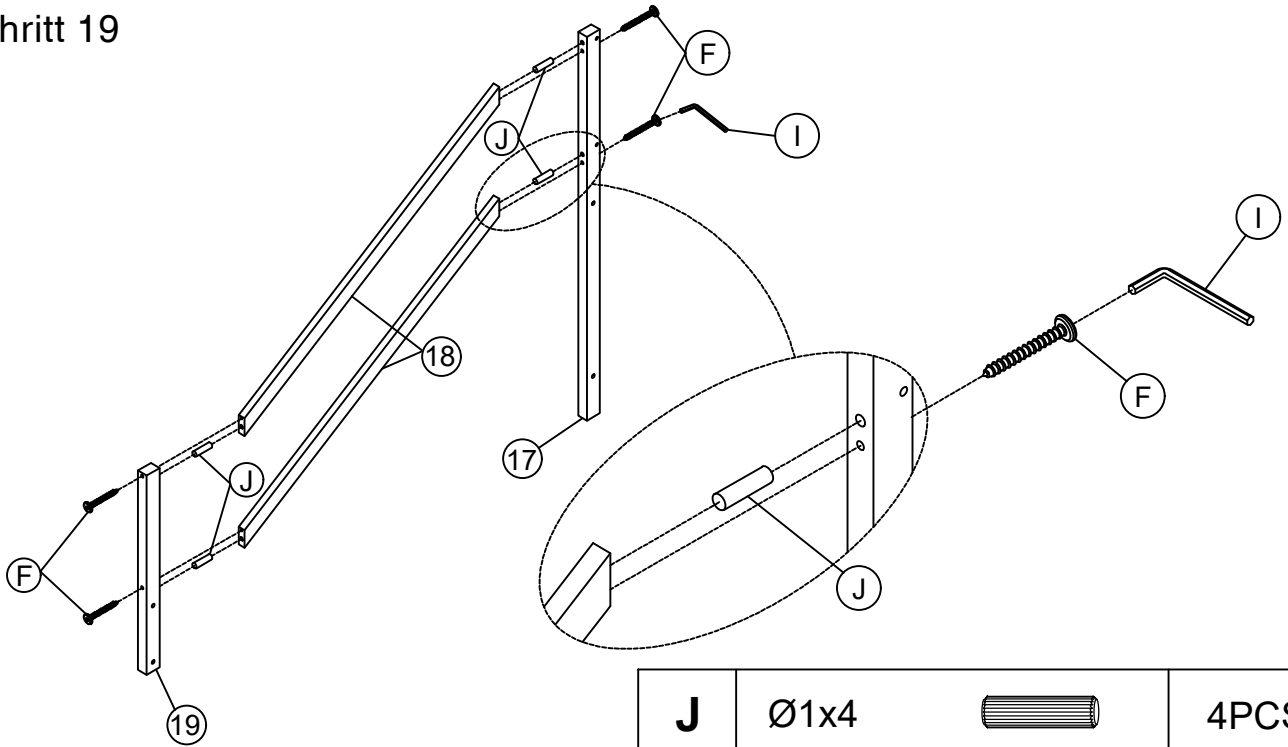

## Schritt 19

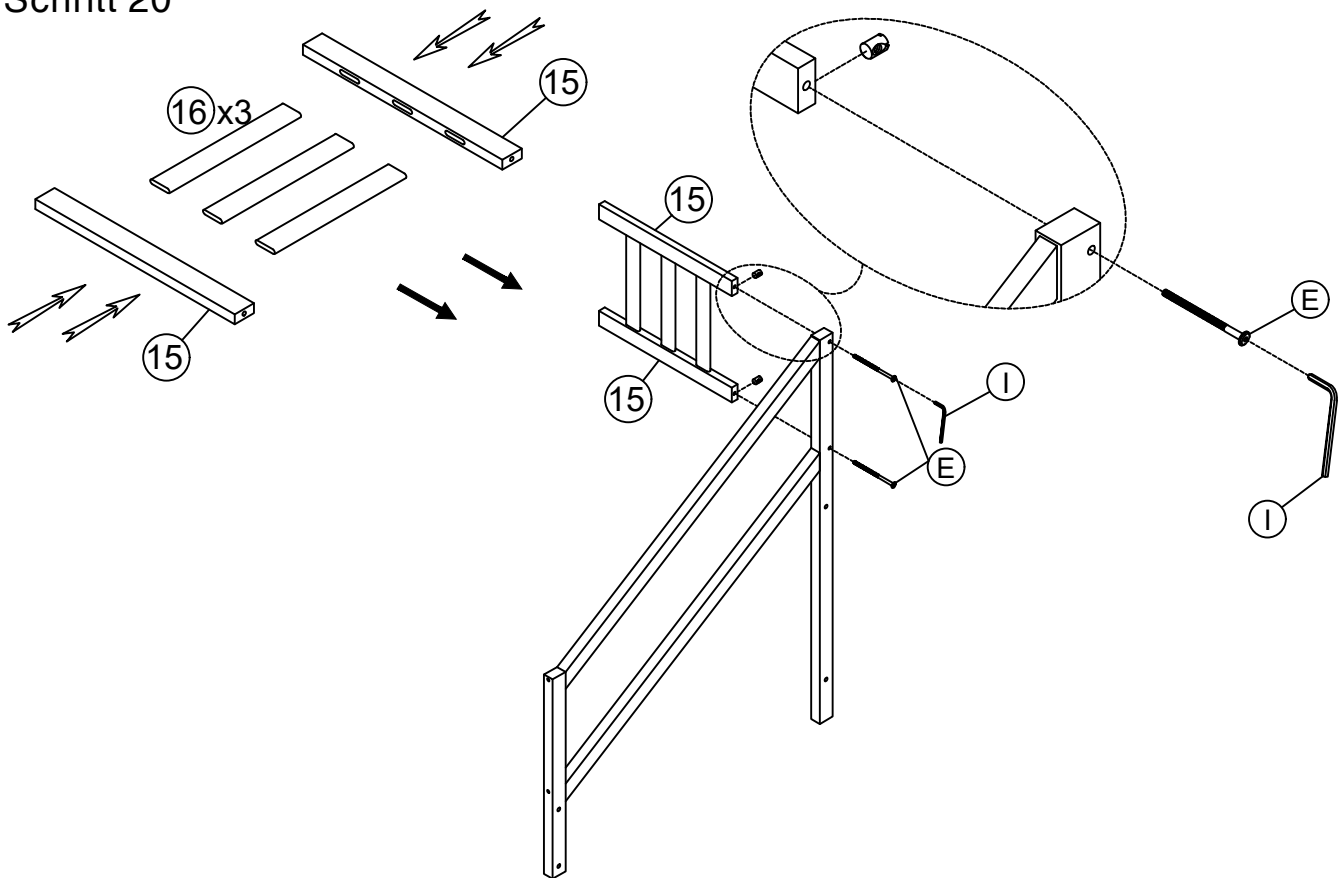

<b>J</b>	Ø1x4		4PCS
<b>F</b>	0.65x9		4PCS
<b>I</b>	0.4x5.8		1PC

## Schritt 20





<b>I</b>	0.4x5.8		1PC	<b>E</b>	0.63x7.5			2PCS
----------	---------	---	-----	----------	----------	---	---	------



# MONTAGEANLEITUNGEN

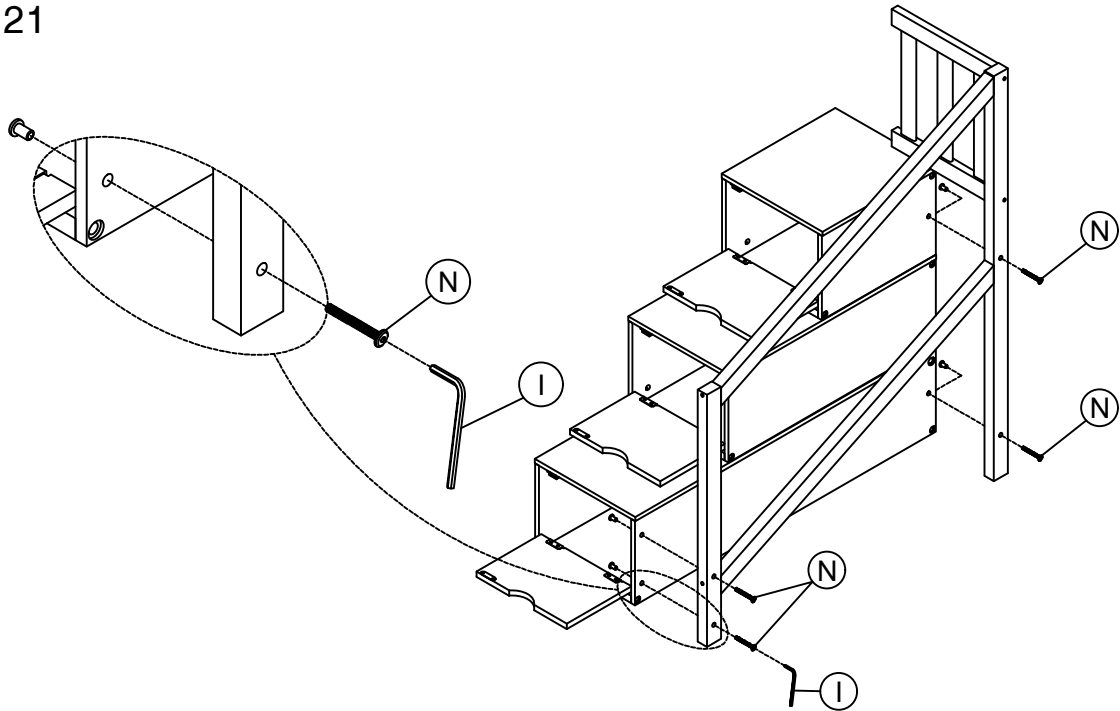

## Schritt 21

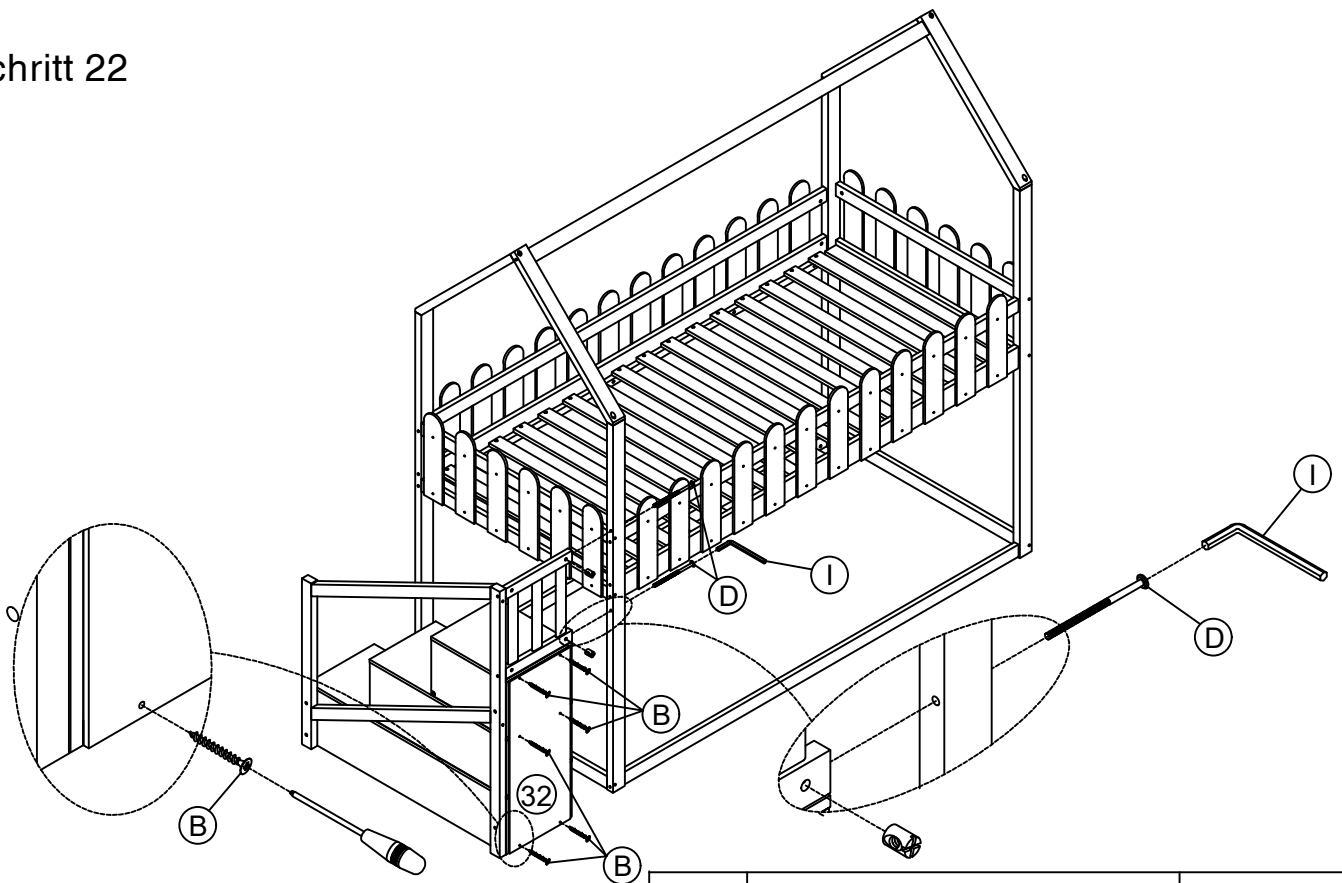

<b>N</b>	0.63x3.5		4PCS	<b>I</b>	0.4x5.8		1PC
----------	----------	---	------	----------	---------	--	-----

## Schritt 22



<b>B</b>	Ø0.35x1.2		6PCS	<b>I</b>	0.4x5.8		1PC
<b>D</b>	0.63x10		2PCS				

# MONTAGEANLEITUNGEN

## Schritt 23

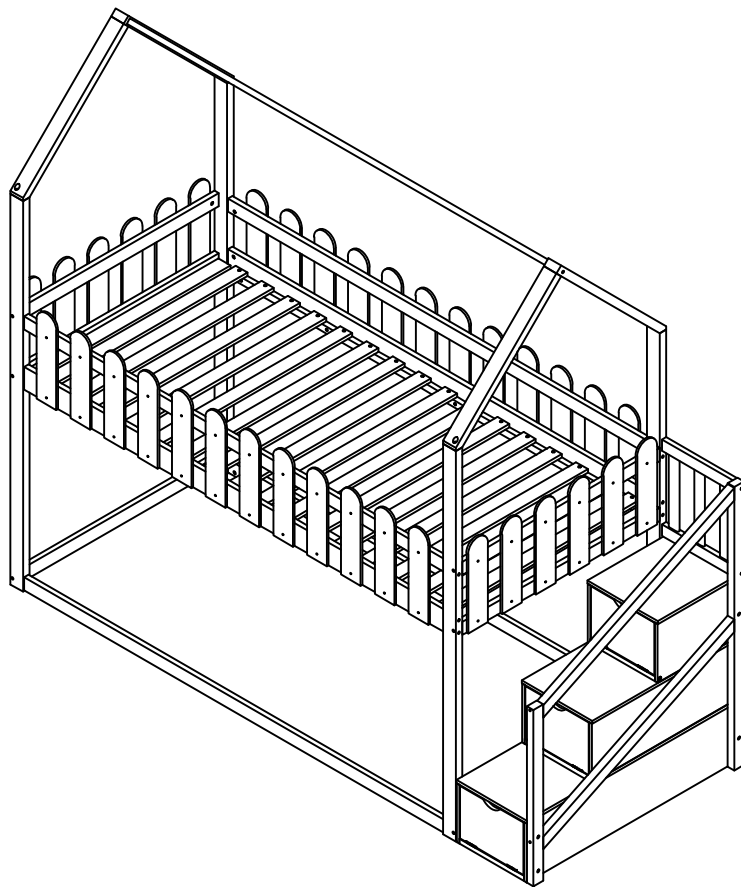
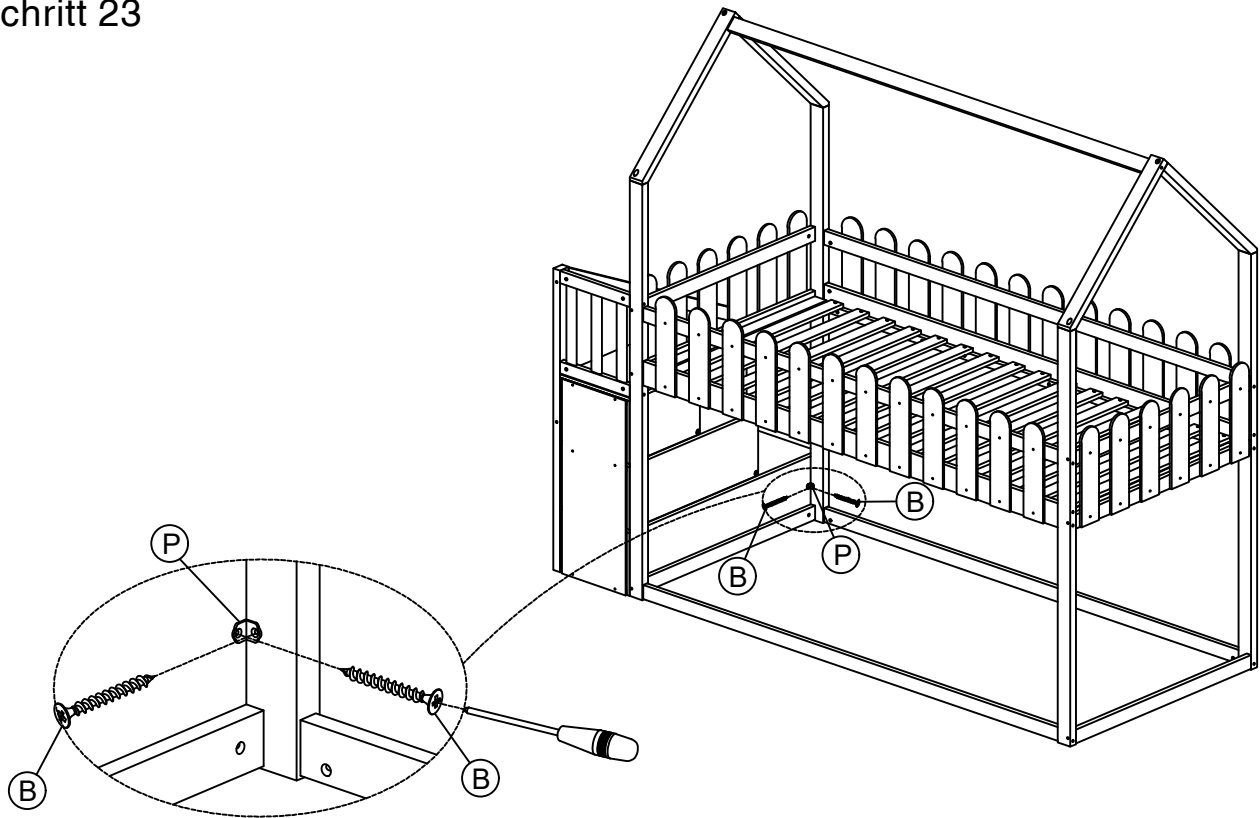

<b>P</b>	1.5x1.5x0.2		1PC	<b>B</b>	Ø0.35x1.2		2PCS
----------	-------------	---	-----	----------	-----------	---	------