

MONTAJE / MONTAGE / MONTAGGIO / MONTAGEM / ASSEMBLY / BEDIENUNGSANLEITUNG

ES | TE ACONSEJAMOS

- Poner el paquete en posición horizontal.
- Ordenar y contar las piezas y herrajes.
- Habilita una zona para el montaje.
- Sigue paso a paso las instrucciones de montaje.

EN | ADVISE YOU

- Put the package in horizontal position.
- Put in the order and count the pieces and iron fittings.
- Take enough space for assembly.
- Follow step by step the assembly instruction.

FR | NOUS VOUS CONSEILLONS

- Poser les colis en position horizontale.
- Classer et compter les éléments de montage et la quincaillerie.
- Définir une zone de montage.
- Suivre dans l'ordre les instructions de montage.

IT | VI INFORMIAMO

- Porre la confezione in orizzontale.
- Mettere in ordine e contare le minuterie metalliche.
- Essere certi di avere spazio a per il montaggio.
- Seguire passo passo le istruzioni.

ES - Las herramientas que necesitas (no incluidas en el kit)

FR - Outils de montage nécessaires (not inclus dans le kit)

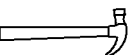

EN - The tools that you need for assembly (not included in the package)

IT - Gli attrezzi che vi servono per il montaggio (non inclusi nella confezione)



ES - Los herrajes que encontrarás en el kit

FR - Quincaillerie incluse dans le kit

EN - The tools that you will find in the package

IT - Accessori inclusi nella confezione.



X1 4,5 x 50 mm



X6 8 x 30 mm



X8 3,5 x 15 mm



X2

ES - Las piezas incluidas en el kit

FR - Pièces incluses dans le kit

EN - The pieces included in the package

IT - Parti incluse nella confezione

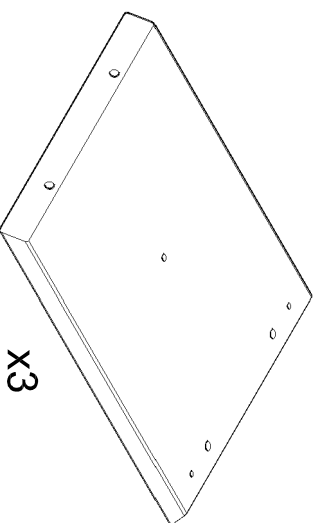

X3

1

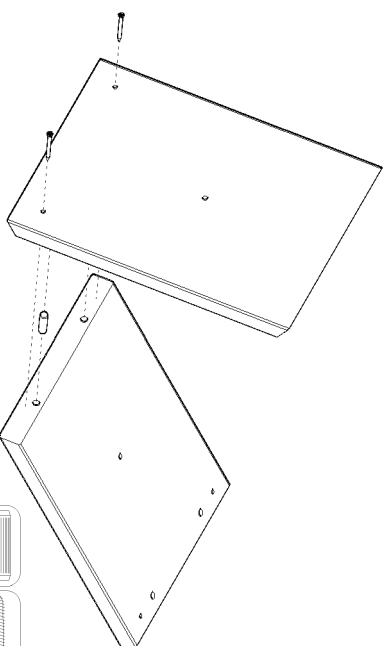

2

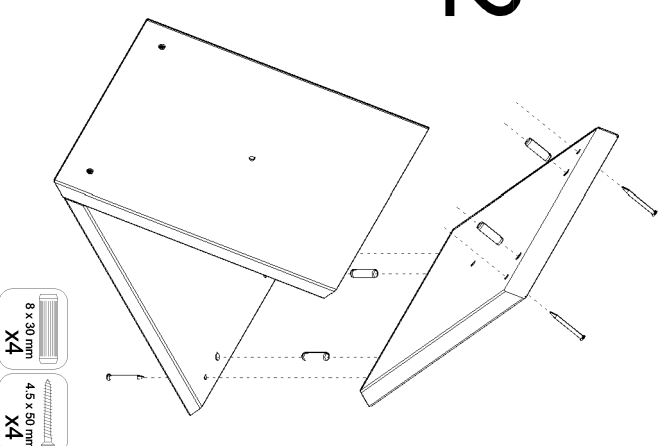

3

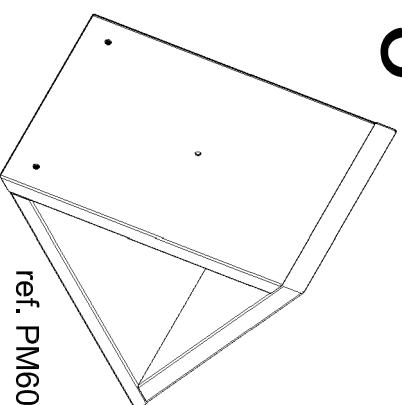

ref. PM6000.99

UNION A PARED - FIXING TO WALL - FIXATION AU MUR - BEFESTIGUNG AN DER WAND

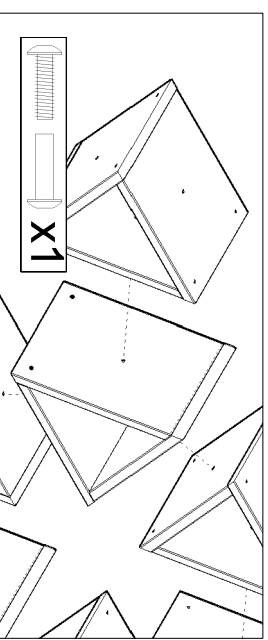
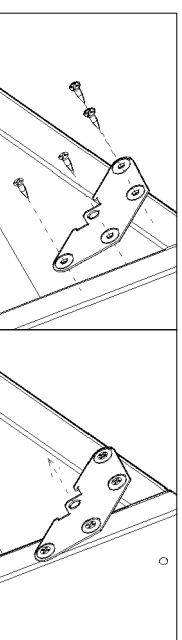

EVOLUTIF

ASTIGARRAGA

ast

Unida Area nº3
Calle Garmatzen 10
E-20720 Astigarraga
T. +34 949 814 261 | F. +34 949 818 713
astigarraga@klifline.es
www.astigarraga.es

