

Montageanleitung | Instructions de montage Assembly Instructions | Instrucciones de montaje

SKU NUMBER: WF325271/WF325272
WF325273/WF325274

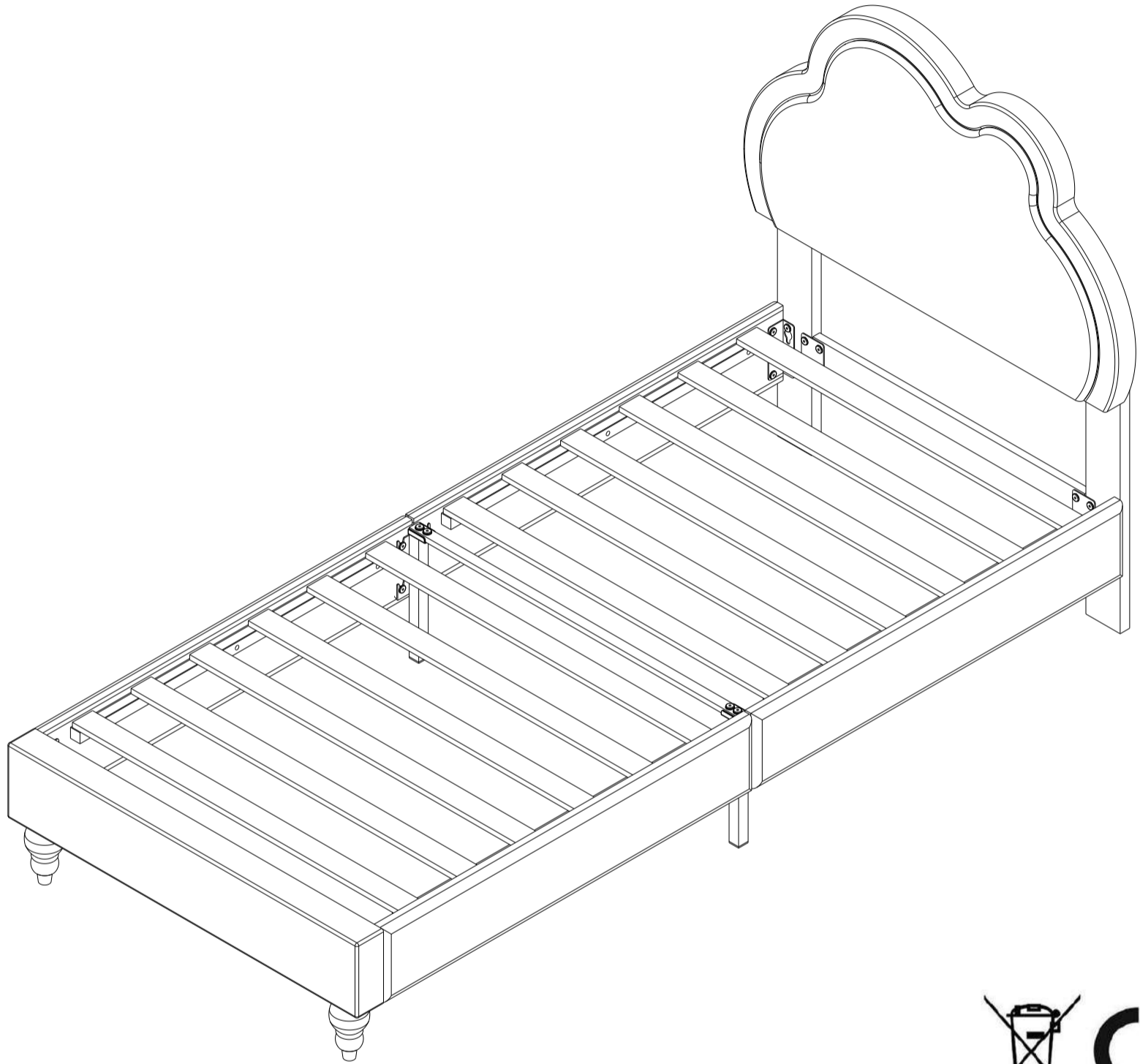

GB This set comes in 2 boxes. If you do not receive a full set of 2 boxes, please contact our customer service.

DE Dieses Set wird in 2 Schachteln geliefert. Wenn Sie nicht ein komplettes Set von 2 Boxen erhalten, kontaktieren Sie bitte unseren Kundenservice.

FR Ce set est livré en 2 boîtes. Si vous ne recevez pas un jeu complet de 2 boîtes, veuillez contacter notre service clientèle.

English

IMPORTANT ! KEEP FOR FUTURE REFERENCE : READ CAREFULLY

- To be assembled by an adult. Assembly must be checked by an adult before use
- WARNING ! Keep all screws, small parts and plastic bags out of the reach of children
- Properly identify all parts before assembling
- Never use your item if any of its parts are broken or missing
- Should any problems arise, please contact our After Sales Service
- Manufacturer's instructions shall be followed at all times
- Care: Clean with a soft, dry cloth. In case of larger stains, carefully rub with a slightly damp, non-abrasive sponge
- Do not jump on the bed

Français

IMPORTANT ! CONSERVER POUR RÉFÉRENCE ULTÉRIEURE : LIRE ATTENTIVEMENT

- Le montage doit être effectué par un adulte. Le montage doit être vérifié par un adulte avant utilisation
- ATTENTION ! Tenir les vis, les petites pièces et les sachets en plastique hors de portée des enfants
- Identifiez correctement toutes les pièces avant de les assembler
- N'utilisez jamais votre article si l'une de ses pièces est cassée ou manquante
- En cas de problème, veuillez contacter notre service après-vente
- Les instructions du fabricant doivent être respectées à tout moment
- Entretien : nettoyer avec un chiffon doux et sec. En cas de taches plus importantes, frotter soigneusement avec une éponge non abrasive légèrement humide. légèrement humide et non abrasive
- Ne pas sauter sur le lit

Deutsch

WICHTIG ! ZUM SPÄTEREN NACHSCHLAGEN AUFBEWAHREN: SORGFÄLTIG LESEN

- Muss von einem Erwachsenen zusammengebaut werden. Der Zusammenbau muss vor dem Gebrauch von einem Erwachsenen überprüft werden
- WARNUNG! Bewahren Sie alle Schrauben, Kleinteile und Plastikbeutel außerhalb der Reichweite von Kindern auf
- Kennzeichnen Sie vor dem Zusammenbau alle Teile richtig.
- Benutzen Sie Ihren Artikel niemals, wenn Teile gebrochen sind oder fehlen
- Sollten Probleme auftreten, wenden Sie sich bitte an unseren Kundendienst
- Die Anweisungen des Herstellers sind stets zu befolgen
- Pflege: Mit einem weichen, trockenen Tuch reinigen. Bei größeren Flecken vorsichtig mit einem leicht feuchten, nicht scheuernden Schwamm abreiben. nicht scheuernden Schwamm
- Nicht auf das Bett springen

💡 More Tips 💡

1

English - Before installation, you can place the parts on a carpet or other soft fabric, in order to avoid damaging your floor.

Français - Avant l'installation, vous pouvez placer les pièces sur un tapis ou un autre tissu doux, afin d'éviter d'endommager votre sol.

Deutsch - Vor der Installation können Sie die Teile auf einen Teppich oder ein anderes weiches Material legen, um eine Beschädigung Ihres Fußbodens zu vermeiden.

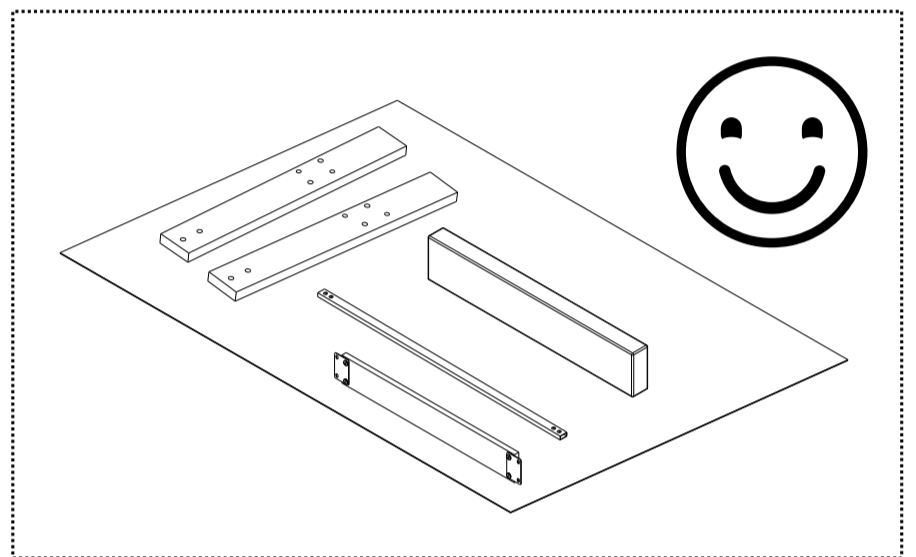
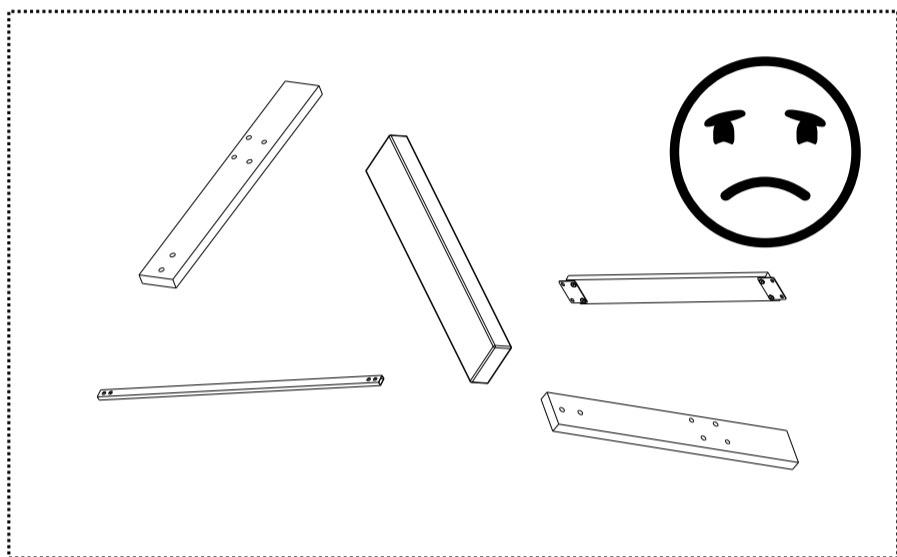

2

English - For your and your family's safety, please do not jump on beds, especially with hydraulic structures. When need to move bed, please work with more than one person to lift, not push, to avoid scratching your floor and hurting the stability of the bed.

Français - Pour votre sécurité et celle de votre famille, ne sautez pas sur les lits, en particulier sur les structures hydrauliques. Lorsqu'il est nécessaire de déplacer le lit, il est préférable de travailler à plusieurs pour le soulever, et non pour le pousser, afin d'éviter de rayer le sol et de nuire à la stabilité du lit.



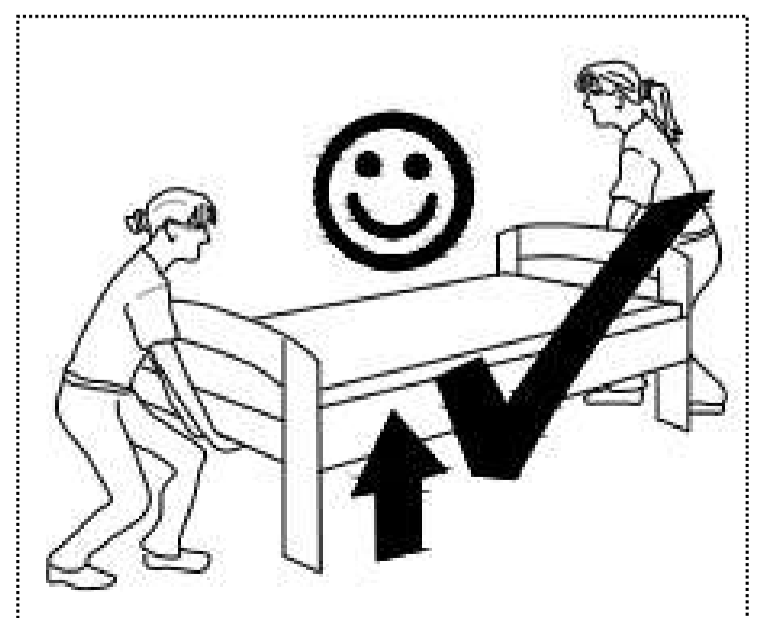

Deutsch - Zu Ihrer Sicherheit und der Ihrer Familie sollten Sie nicht auf Betten springen, insbesondere bei hydraulischen Konstruktionen. Wenn Sie das Bett bewegen müssen, heben Sie es bitte mit mehreren Personen an und schieben Sie es nicht, um den Boden nicht zu verkratzen und die Stabilität des Bettes nicht zu beeinträchtigen.

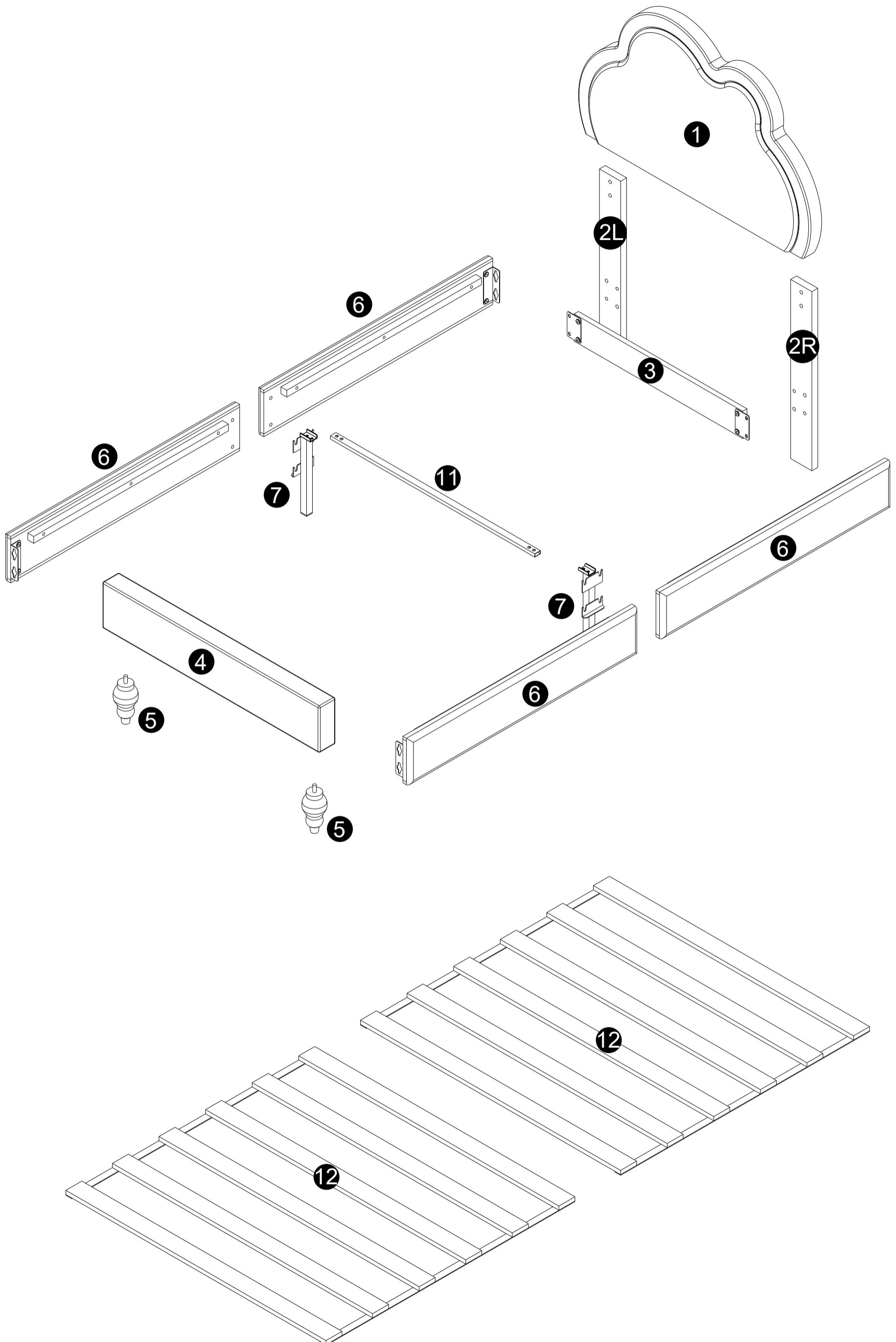

Stückliste

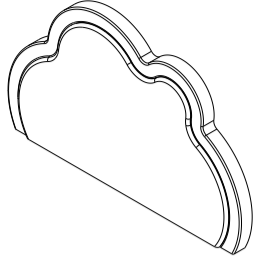

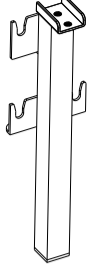

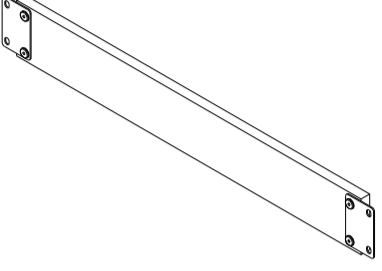
WF325271/WF325273

1		X1	2R		X1	7		X2
2L		X1	3		X1			

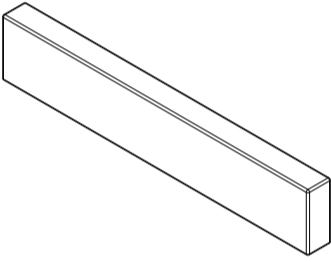
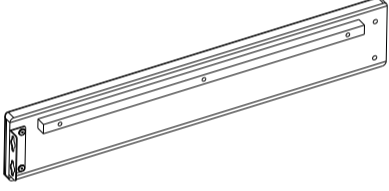
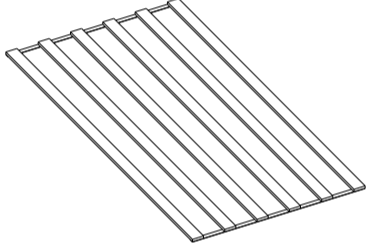
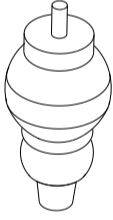
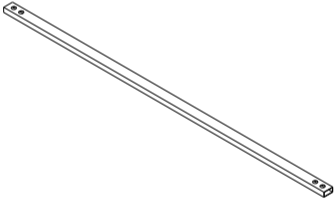
WF325272/WF325274

4		X1	6		X4	12		X2
5		X2	11		X1			

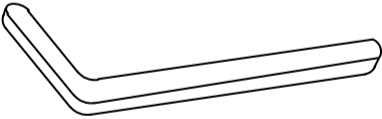
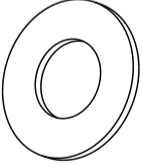

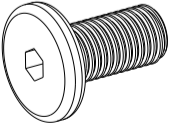
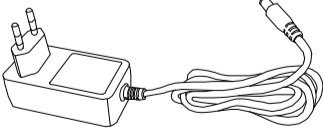
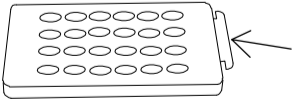
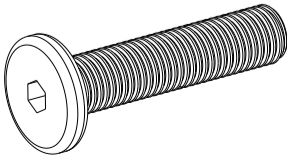
Hardware List-Hardware-Liste-Liste du matériel WF325271/WF325273

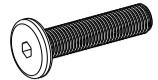
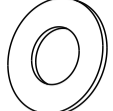
A		X1	D		X8	F		X1
B	 M8x20mm	X16	E		X1	G		X1
C	 M8x40mm	X8	05/12					

1	A x 1	C x 4	D x 4
		 M8 x 40mm	

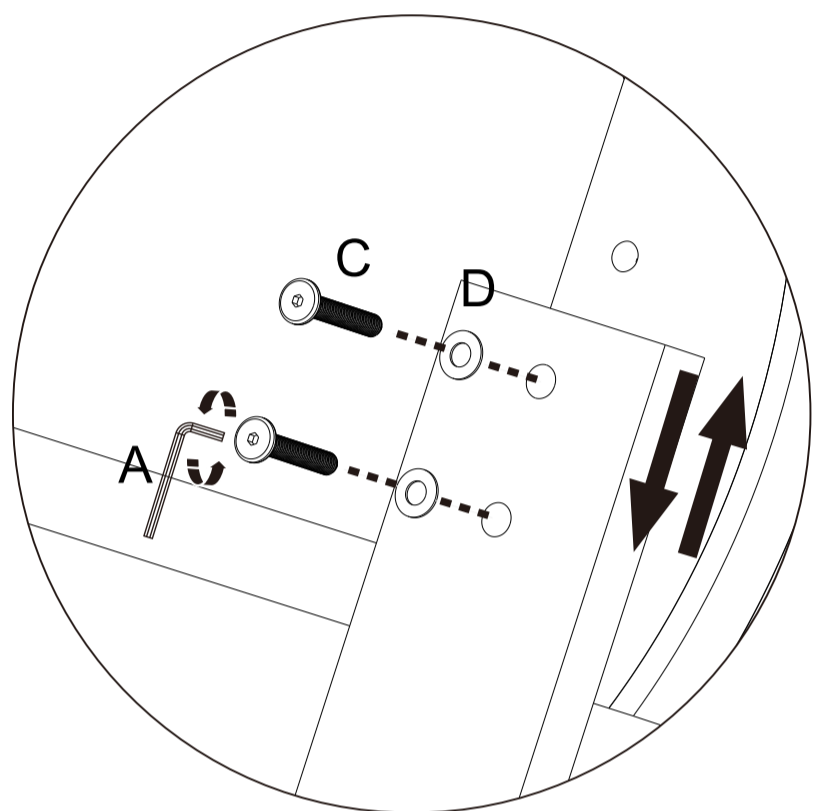
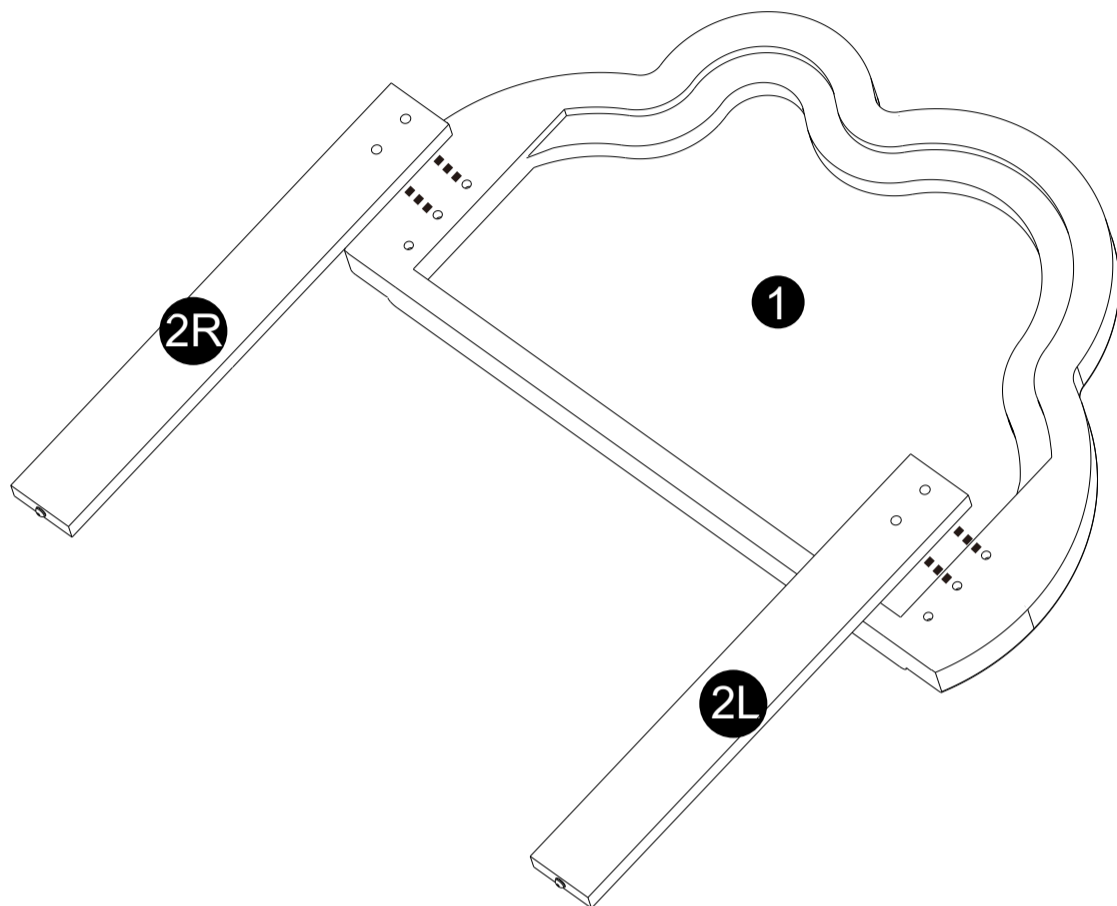
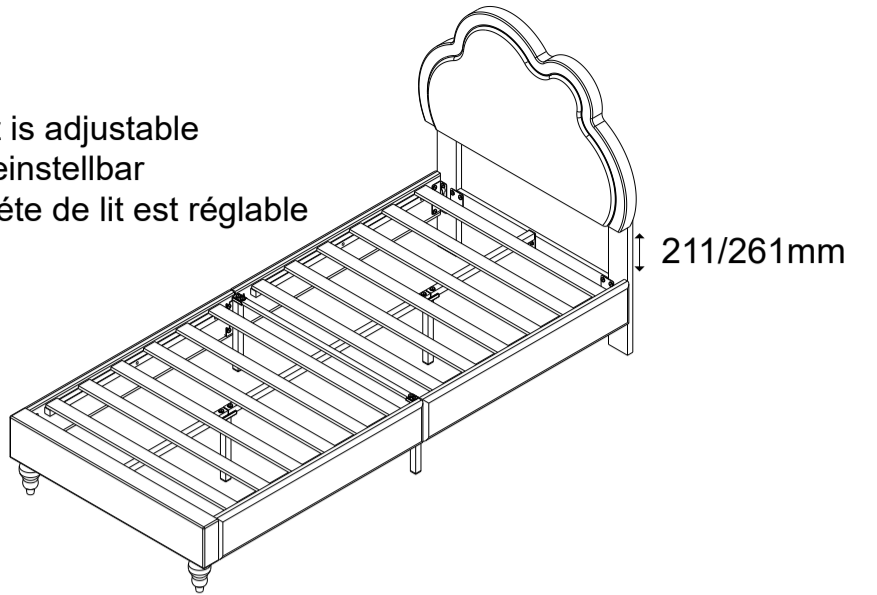
Headboard height is adjustable
 Kopfteil ist Hohe-einstellbar
 La hauteur de la tête de lit est réglable



2	A x 1	B x 8
		 M8 x 20mm

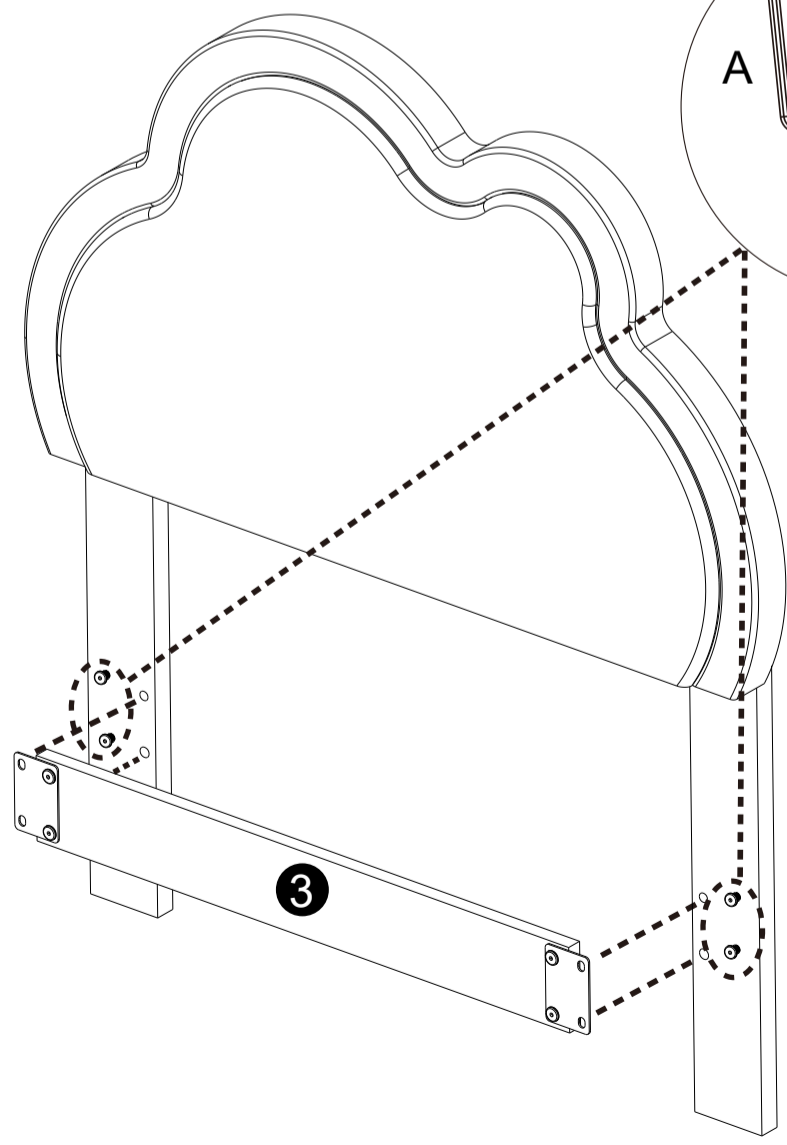
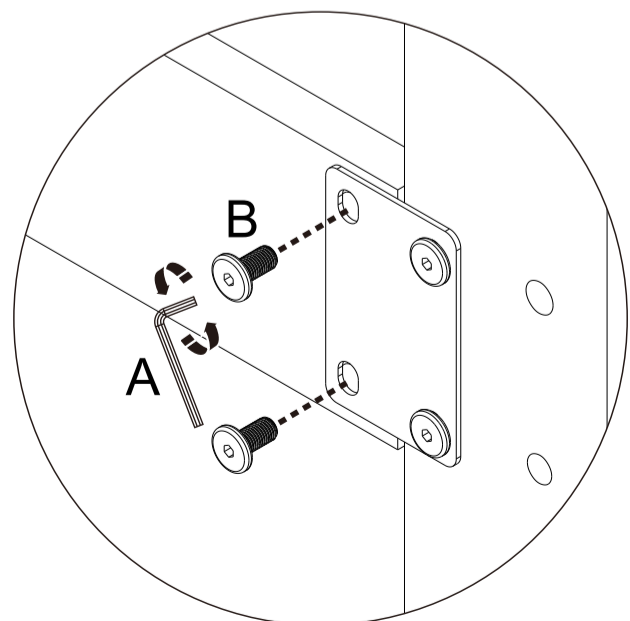
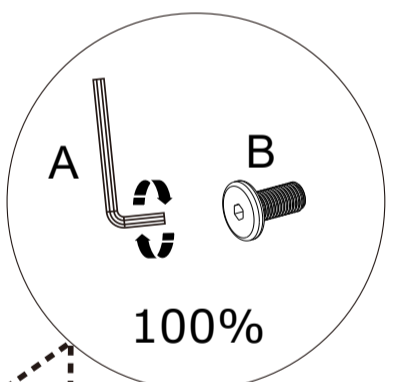

3

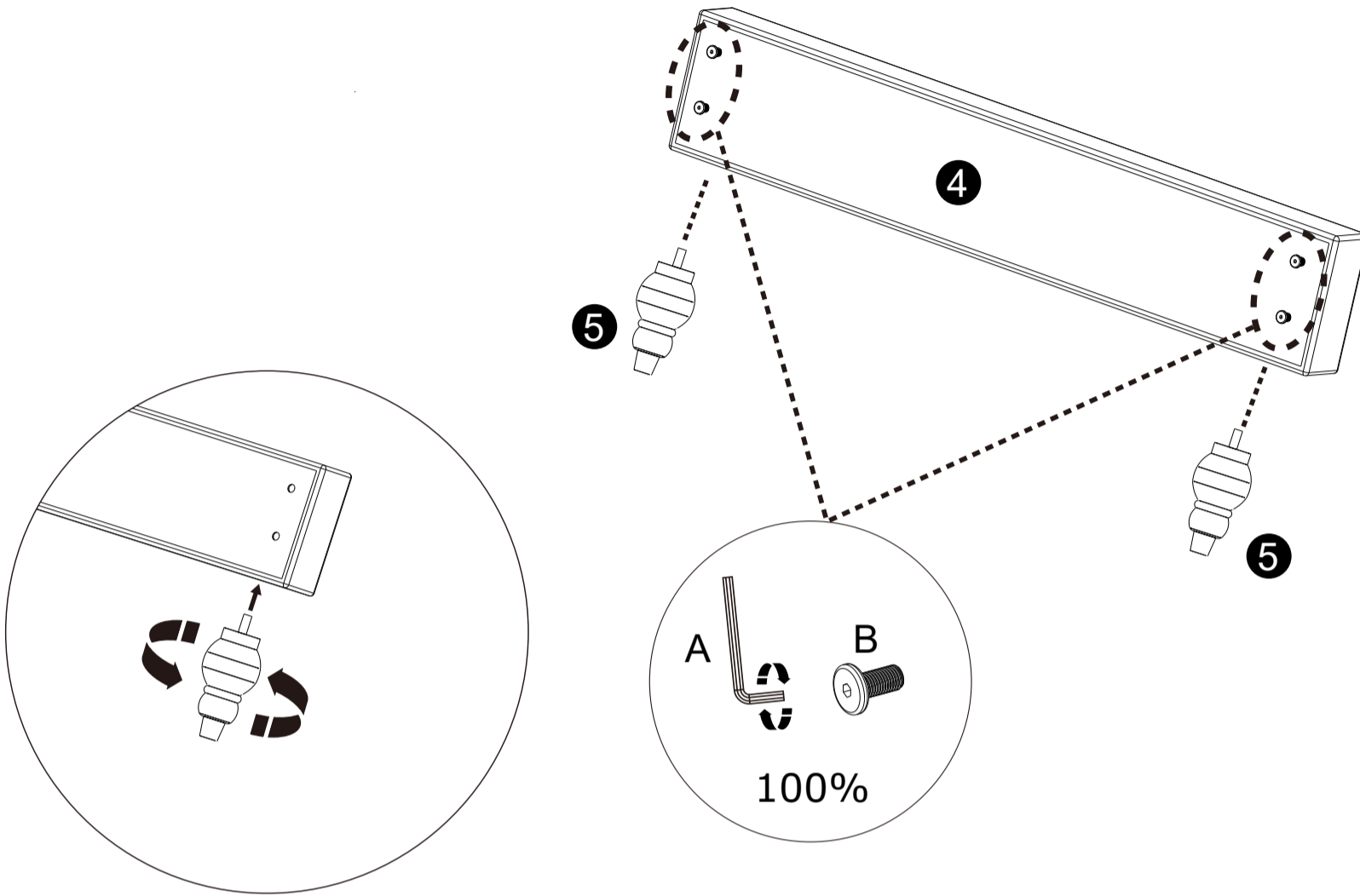

4

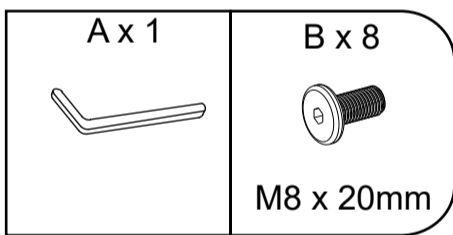

2pcs

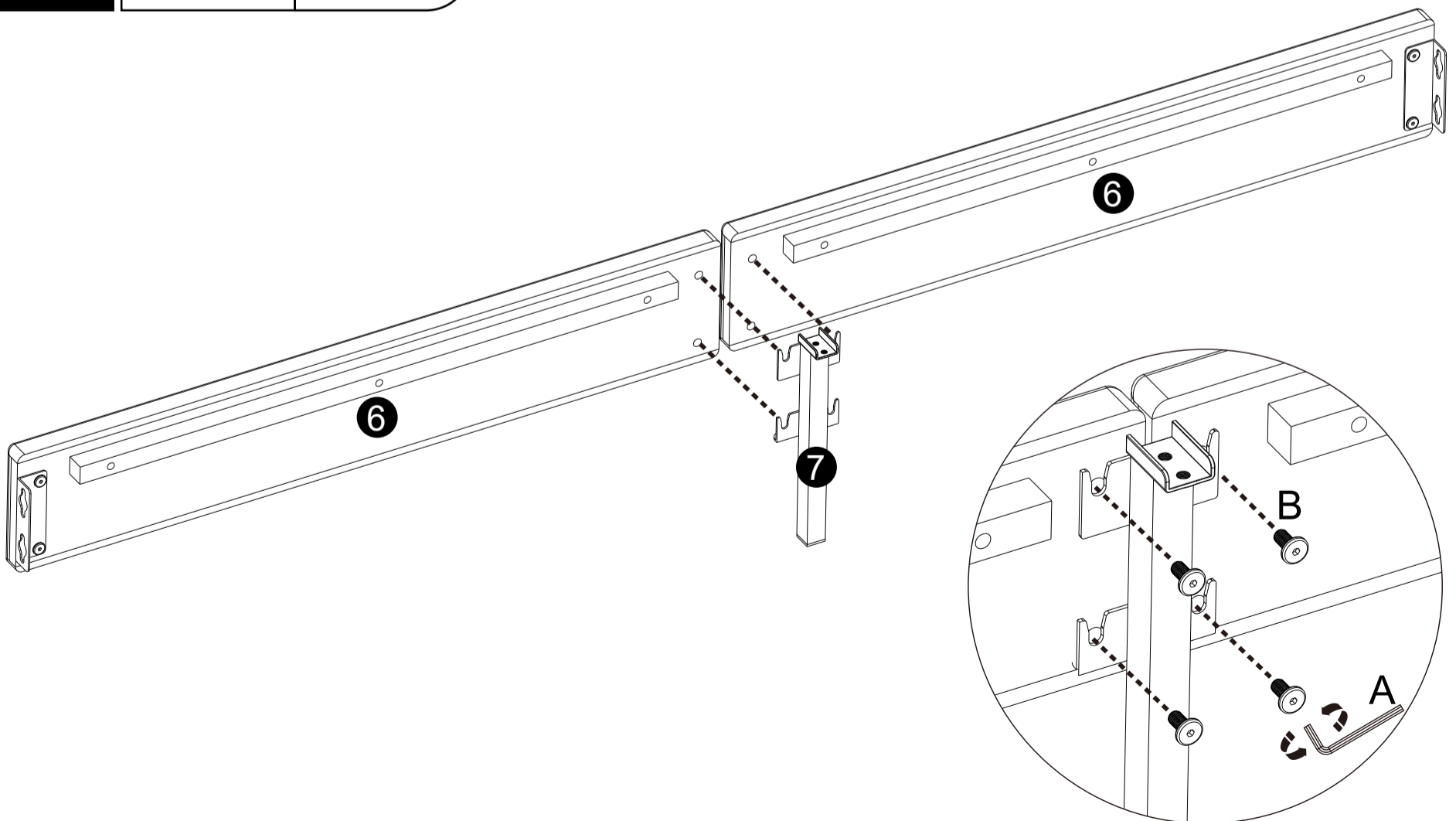

5 Ax1

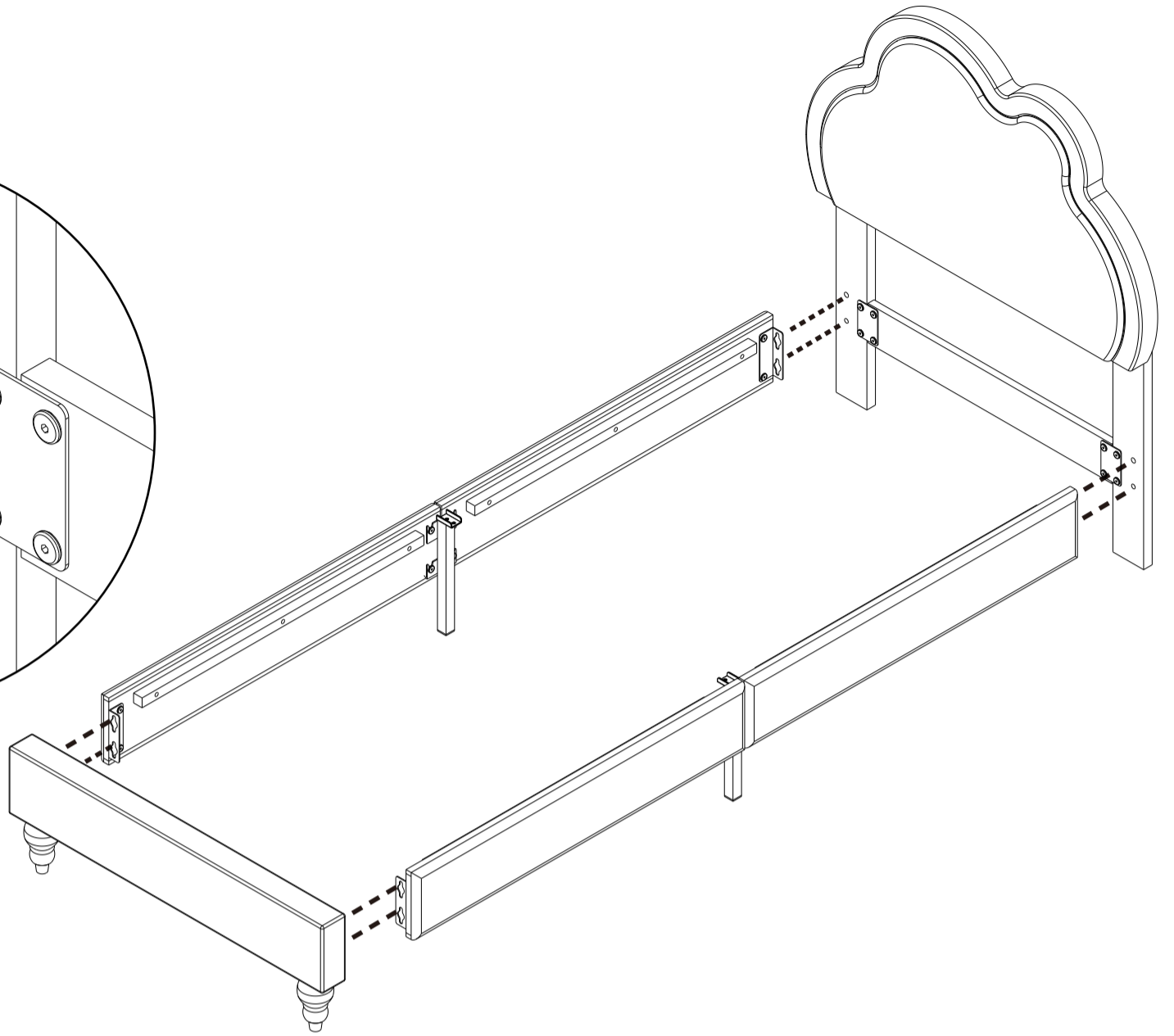
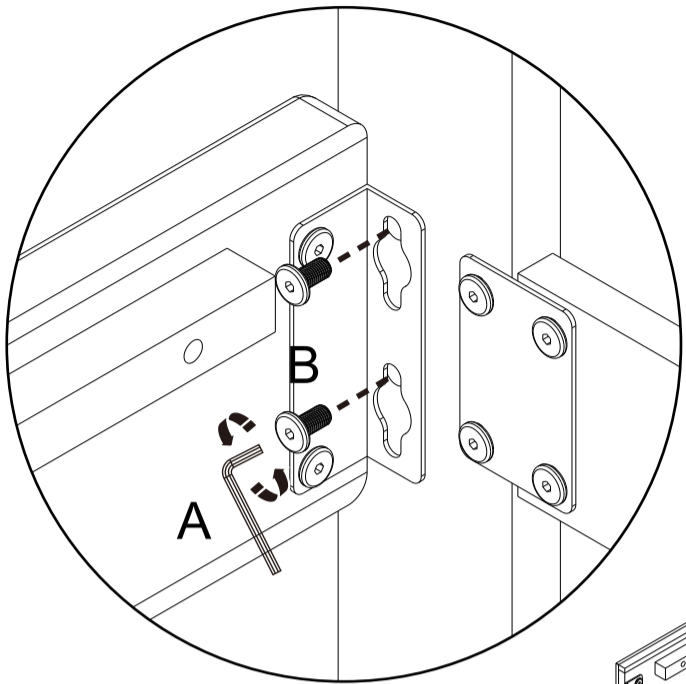
6 Ax1 Cx4 D x 4
M8 x 40mm

7

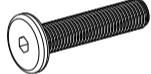
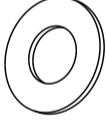
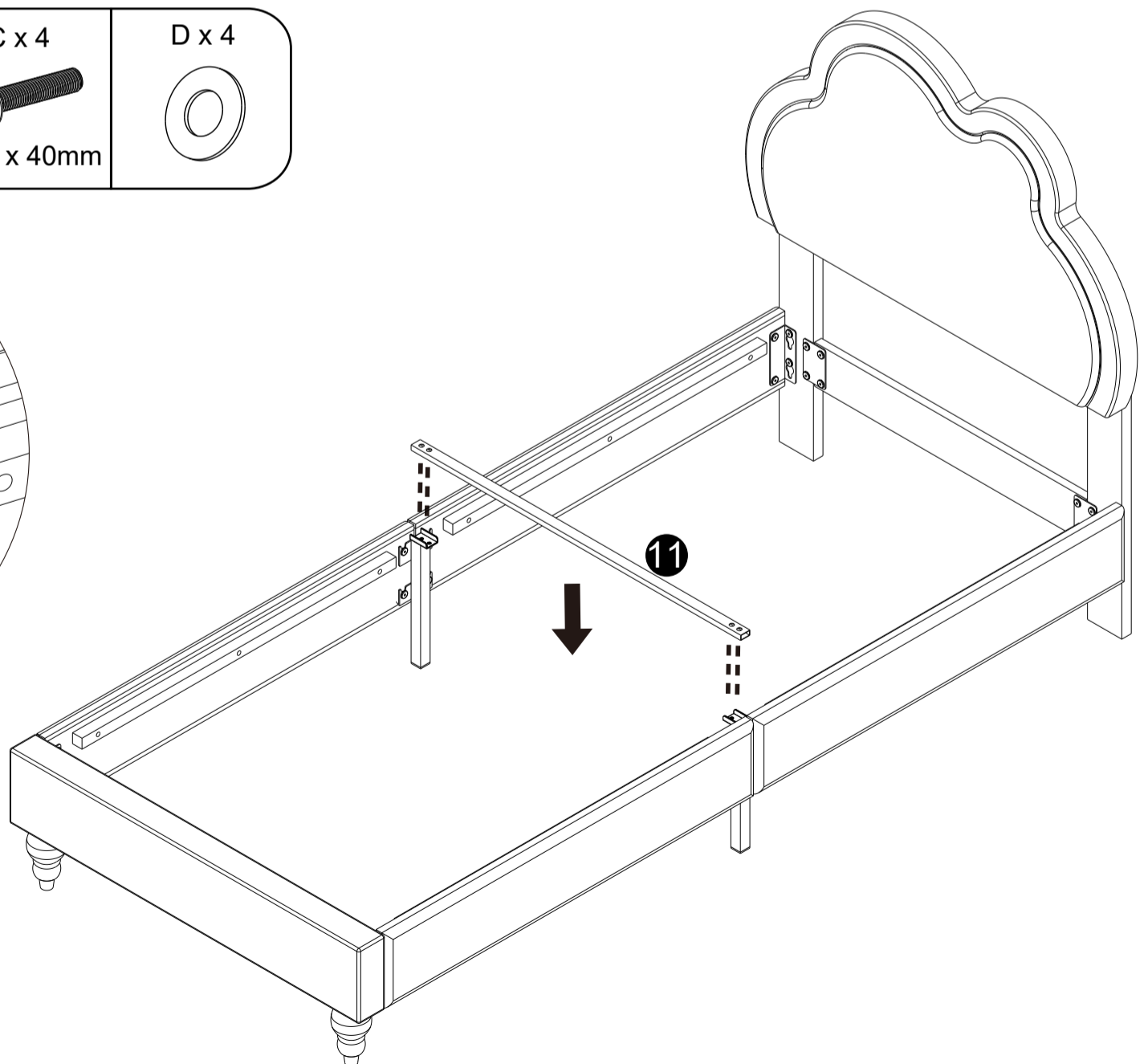
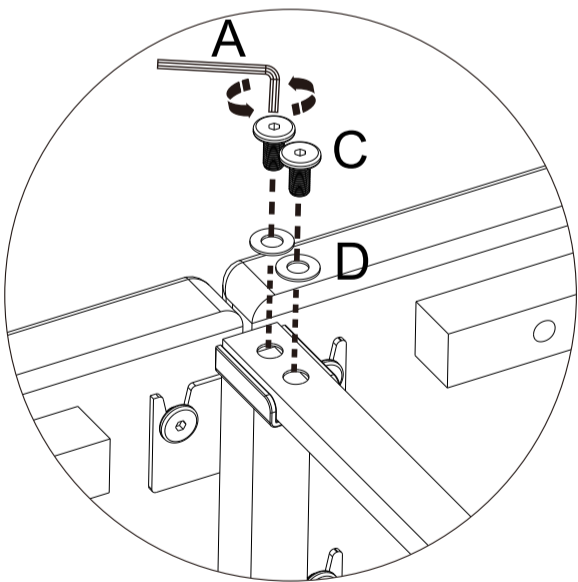

8

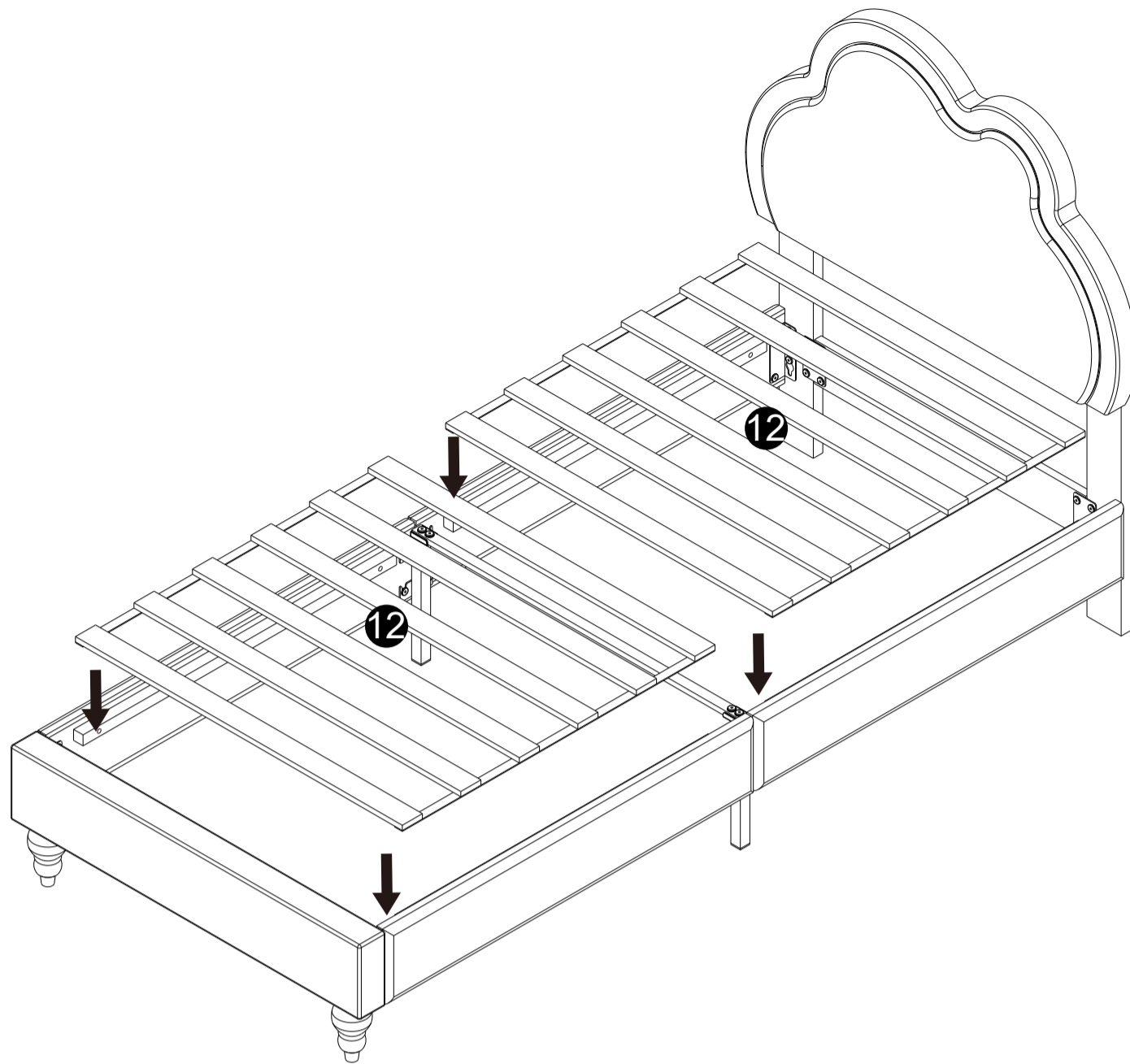

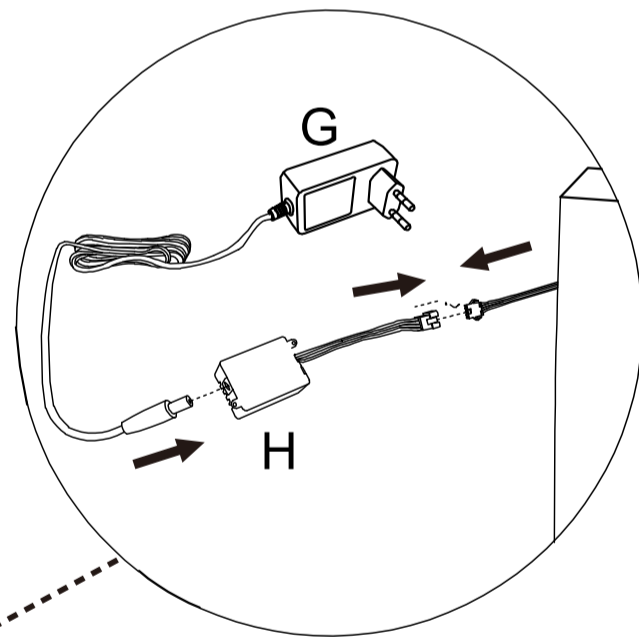
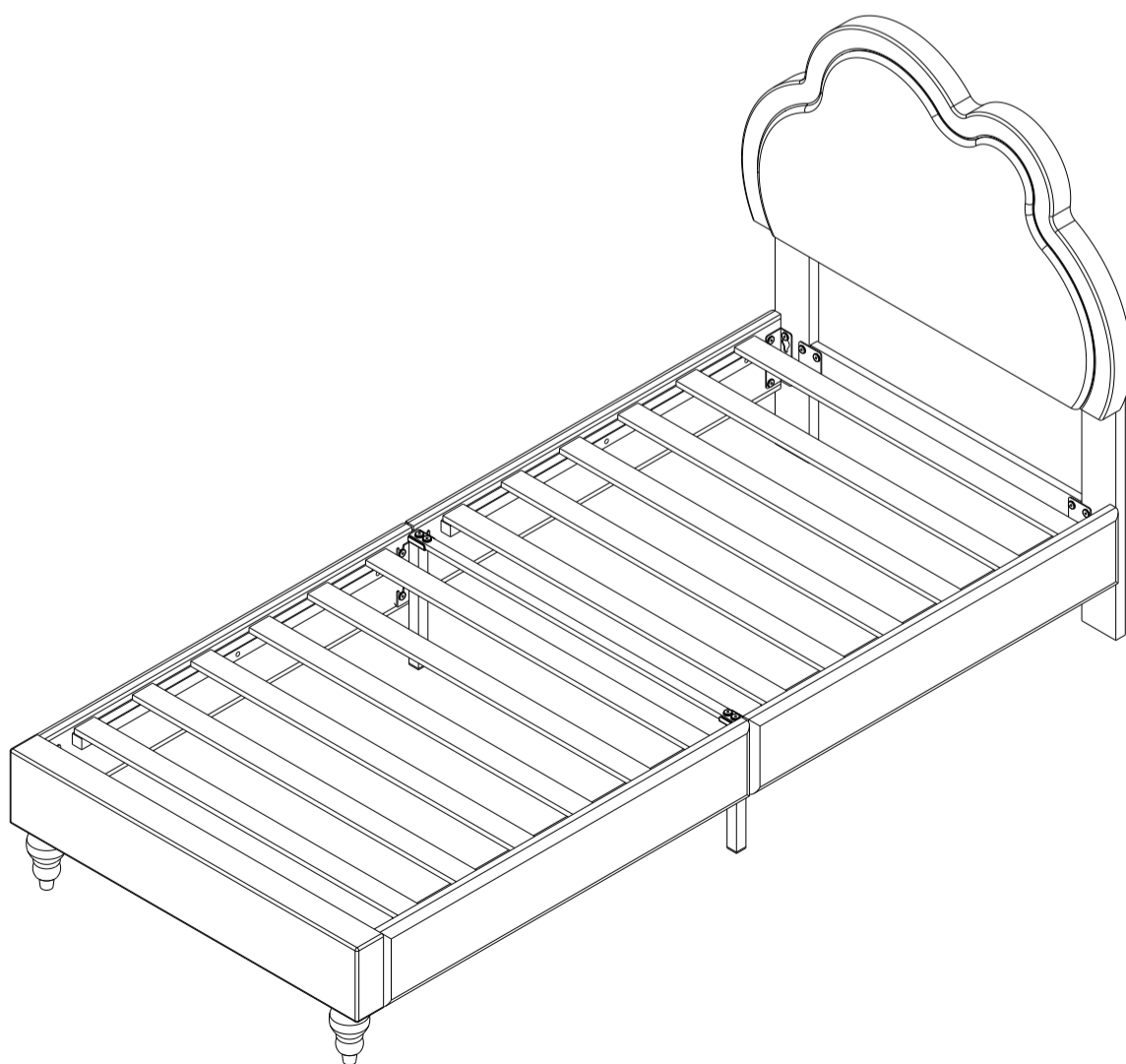
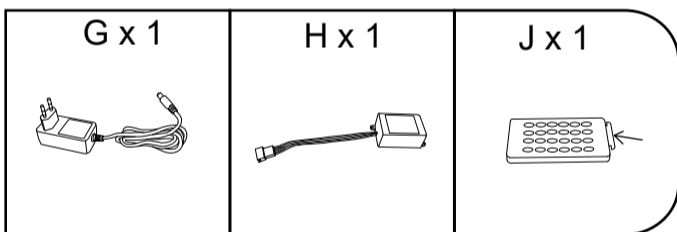
LED light

If you can't let the lights work successfully, please check the following:

1. Please check the direction of the connect, try it in the opposite direction, according to the following picture.
2. Please ensure to tear down the plastic septum of remote control before using.
3. If one of the colors is not bright, please check whether the four wires in the plug are skewed, and move the main line to make the four wires flush.

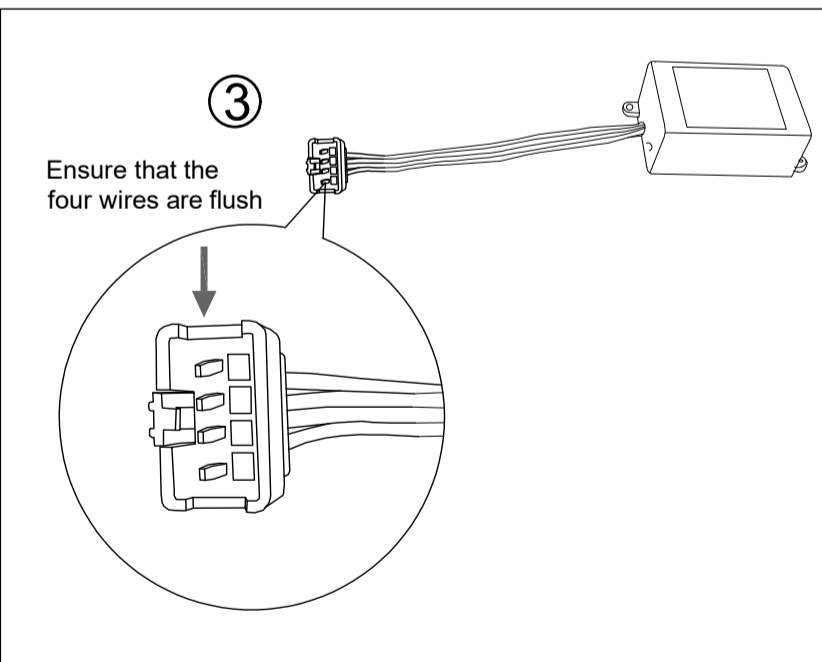
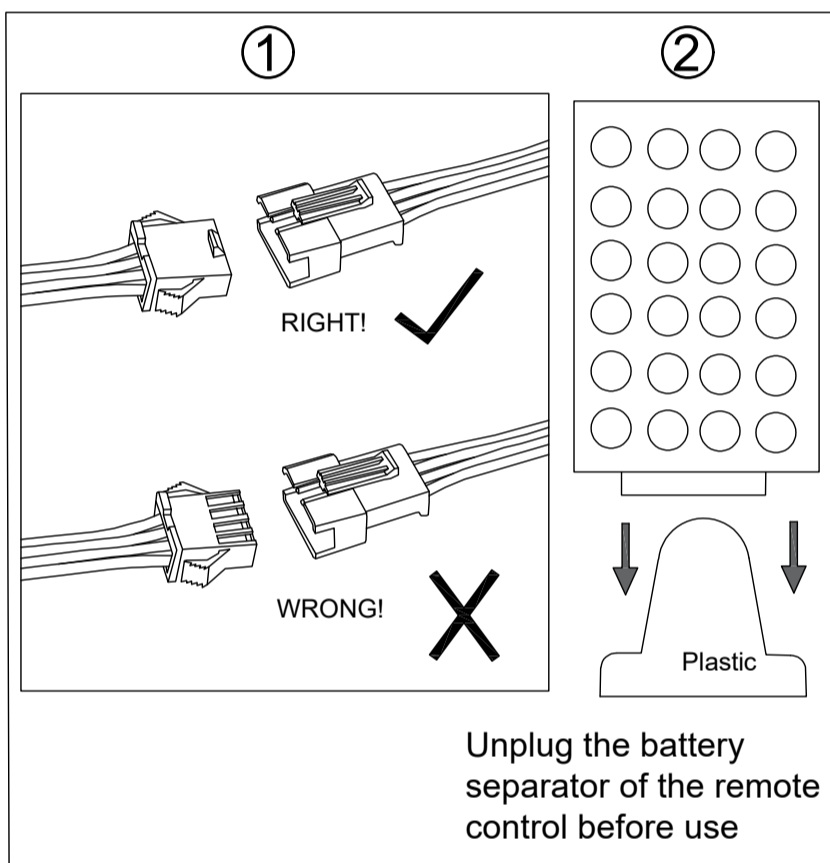

- 1 Please check the direction of the arrow
- 2 Please pull the plastic block out of the remote control
- 3 Please check whether the four wires of the plug are neat

Operation Instructions of Controller

I. Specifications:

Working temperature : -20-60 °C Supply voltage: DC12V
 Output: Three CMOS drain- open output Connecting Mode : Common anode
 Max load current : 2 A each color

II. Control Method:

Adopt RF remoter to control the led controller, which has 24 buttons, the function of each button as the table below:

Brightness +(Speed up)	Brightness - (Speed down)	Off	On
Static red	Static green	Static blue	Static white
Static orange	Static pea green	Static dark blue	7 color jumpy change
Static dark yellow	Static cyan	Static brown	All fade out&fade in
Static yellow	Static light blue	Static pink	7 color fade change
Static straw yellow	Static sky blue	Static purple	3 base color jumpy

III. Panel specification and connecting drawing as follows:

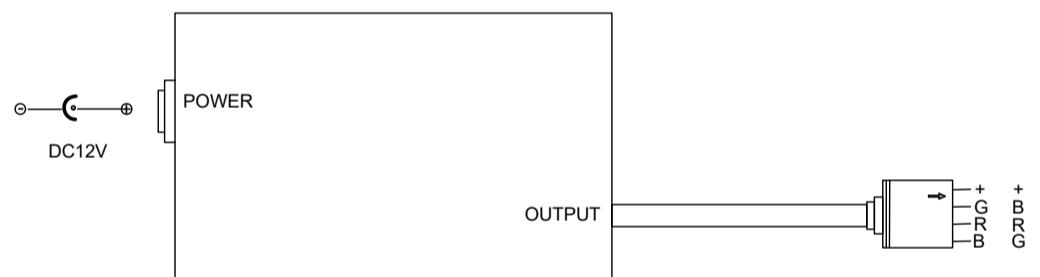

IV. Warning:

1. Supply voltage of this product is DC12V never connect to DC24V or AC220V.
2. Never connect two wires directly in case of short circuit.
3. Lead wire should be connected correctly according to colors that connecting diagram offers.
4. Warranty of this product is one year, in this period we guarantee replacement or repairing with no charge, but exclude the artificial situation of damaged or overload working.

! WARNING

THIS PRODUCT CONTAINS A BUTTON BATTERY
 If swallowed, a lithium button battery can cause severe or fatal injuries within 2 hours.
 Keep batteries out of reach of children.
 If you think batteries may have been swallowed or placed inside any part of the body, seek immediate medical attention.

Certificate of Compliance

Certificate No.: PRMS2205006SC

Holder : Shenzhen Boyaxuan Technology Development Co., Ltd.
3 / F, building 1, No.8, Xingye 1st Road, Fenghuang
community, Fuyong Street, 518103 Shenzhen, PEOPLE'S
REPUBLIC OF CHINA

Manufacturer : Shenzhen Boyaxuan Technology Development Co., Ltd.
3 / F, building 1, No.8, Xingye 1st Road, Fenghuang
community, Fuyong Street, 518103 Shenzhen, PEOPLE'S
REPUBLIC OF CHINA

Trade Mark : N/A

Product : AC/DC Adapter

Model(s) : BYX2-XXXYYYYZ
(‘XXX’=050 to 252, indicates 3 digit numbers which represents output
voltage in V after diving by 10; ‘YYYY’=0010 to 4000, indicates 4 digit
numbers which represents output current in A after diving by 1000;
Z= E, C or blank)

Rating : Input: 100-240Vac, 50/60Hz, 0.5A Max.
Output: See report

Test Standard : EN 62368-1:2014+A11:2017

The EUT described above has been tested by us with the listed standards and found in compliance with the council LVD directive 2014/53/EU. It is possible to use CE marking to demonstrate the compliance with this LVD Directive. It is only valid in connection with the test report number: PRMS2205006SR.



This Certificate of Conformity is based on single evaluation of the submitted sample(s) of the above mentioned product. It does not imply an assessment of the whole product and relevant . Directives have to be observed.



Shenzhen Promise Testing Technology Co., Ltd.
103, Building 1, Yibaolai Industrial City, Qiaotou Community,
Fuhai Street, Bao'an District, Shenzhen, Guangdong, China



Certificate of Compliance

Certificate NO.: PRMS2205006EC01

Holder : Shenzhen Boyaxuan Technology Development Co., Ltd.
3 / F, building 1, No.8, Xingye 1st Road, Fenghuang community,
Fuyong Street, 518103 Shenzhen, PEOPLE'S REPUBLIC OF CHINA

Manufacturer : Same as Hodler

Product : AC/DC Adapter

Model(s) : BYX2-0504000, BYX2-2521100 (See section 2.2 of the report)

Trade Mark : 

Test Standard : EN 55032:2015/A11:2020
EN 55035:2017/A11:2020
EN IEC 61000-3-2:2019/A1:2021
EN 61000-3-3:2013/A2:2021

The EUT described above has been tested by us with the listed standards and found in compliance with the council EMC Directive 2014/30/EU. It is possible to use CE marking to demonstrate the compliance with this EMC Directive. It is only valid in connection with the test report number: PRMS2205006ER-01.



Approved by 
Authorized signatory 

This Certificate of Conformity is based on single evaluation of the submitted sample(s) of the above mentioned product. It does not imply an assessment of the whole product and relevant Directives have to be observed.



+86-0755-23319501

info@pnms-test.com

www.pnms-test.com