

(D) Montageanleitung

(I) Istruzioni di montaggio

(CZ) Montážní návod

LKZ 41194

(GB) Assembly instructions

(NL) Handleiding voor de montage

(SK) Návod na montáž

(F) Notice de montage

(PL) Instrukcja montażu

(HU) Szerelési útmutató

(RO) Instrucțiunile de montaj

(TR) Montaj talimatı

(RU) Инструкция по монтажу



KOLDING KO-11

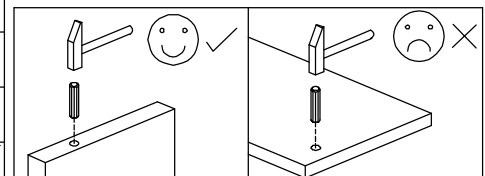
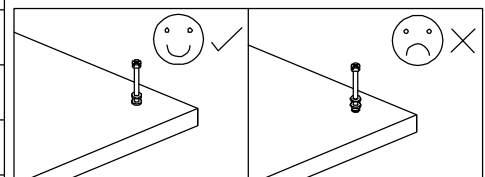
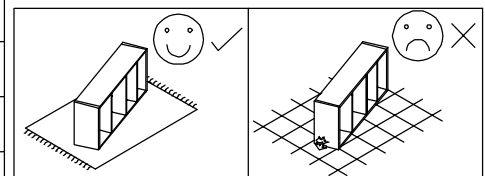
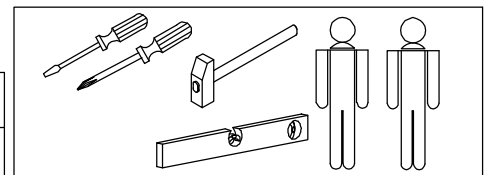
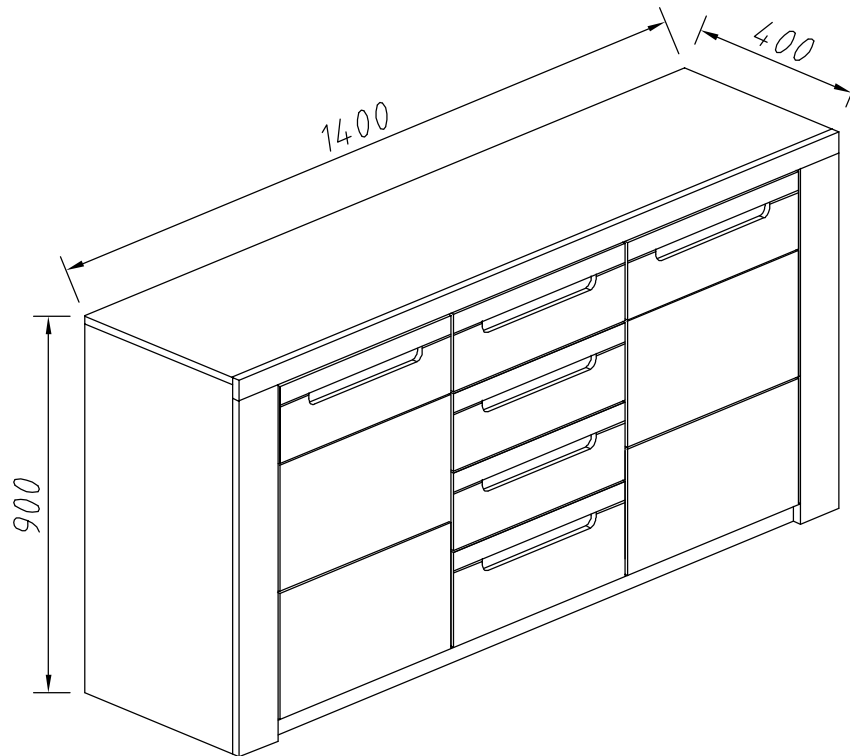







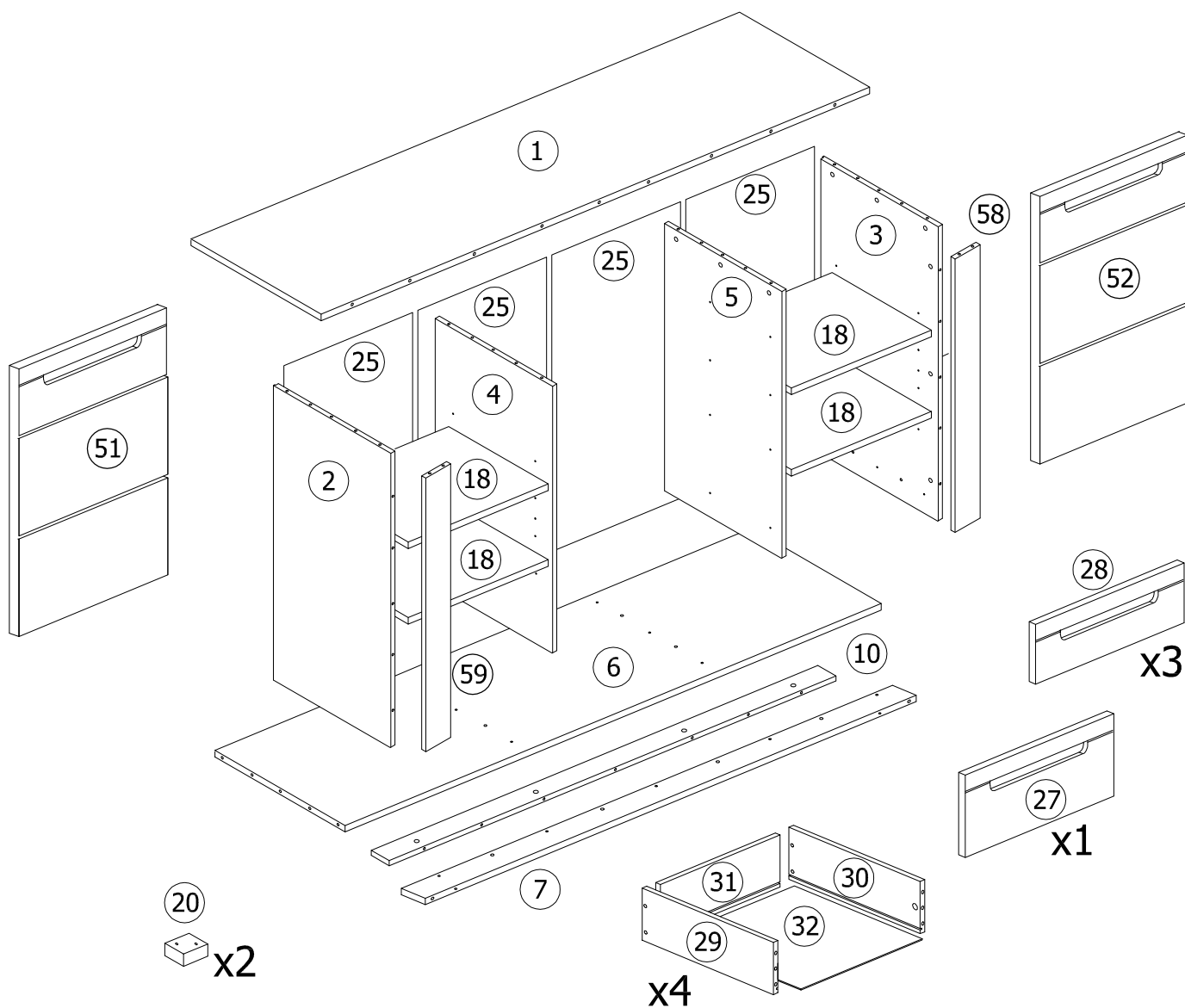
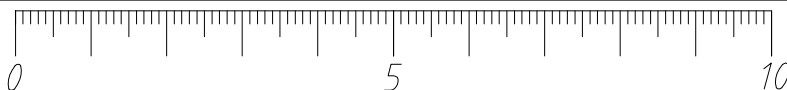
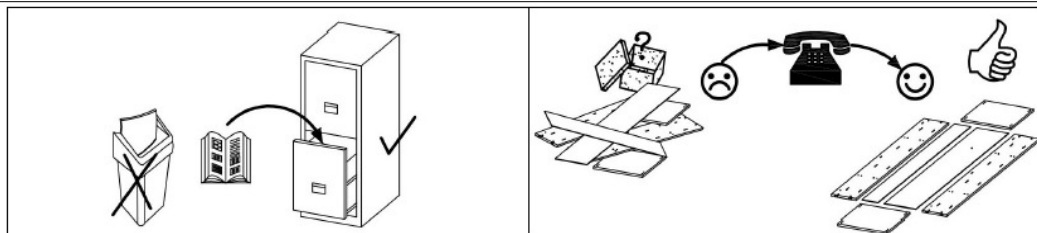

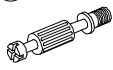

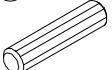

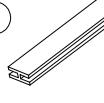
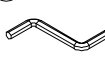

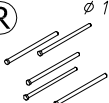
! Uwaga • Achtung • Attention • Caution • Figyele • Attenzione • Opgeet Atentje • Upozornenie • Dikkat • Upozornini • Внимание !	
(D)	Bitte nur mit einem Staubtuch oder leicht feuchtem Lappen reinigen. Keine scheuernden Putzmittel verwenden
(GB)	Please only with a duster or a damp cloth. Do not use any abrasive cleaners
(F)	Le nettoyage se fait uniquement à l'aide d'un torchon ou d'une serviette légèrement mouillée
(RO)	Curățarea trebuie efectuată numai o cârpă sau cu un prosop ușor umezit. Nu utilizați agenți de curățare abrazivi
(I)	Pulire esclusivamente con un panno o un asciugamano umido
(NL)	Reinig alleen met een stofdoek of een lichtjes vochtige doek Gebruik geen schurende poetsmiddelen
(PL)	Czyszczenie należy wykonać wyłącznie za pomocą ściereczki lub lekko nawilżonego ręcznika. Nie stosować środków czyszczących do szorowania
(TR)	Lütfen sadece bir toz beziyile veya hafif nemli yumuşak bir bezle siliniz. Aşındırıcı temizlik malzemeleri kullanmayınız
(CZ)	Čistění je nutné vykonávat výhradně pomocí utěrky nebo lehce navlhčeného ručníku. Nepoužívejte čističí prostředky obsahující abrazivní částice
(SK)	Čistení je nutné vykonávať výhradne pomocí utierky alebo ľahko zvlhnutým ručníkom Nepoužívajte čistiaci prostriedky obsahujúce abrazívni častice
(HU)	A tisztítás kizárólag törölkőruha vagy enyhén nedvesített törülköző segítségével végezhető. Súroló hatású tisztítószereket nem szabad használni
(RU)	Очищайте от пыли тряпкой или слегка влажной ветошью. Не допускается применение чистящих средств, не пред-назначенных для ухода за мебелью.

- (D) Servicekarte (RO) Carte de service (PL) Karta serwisowa (SK) Služobný preukaz
 (GB) Service card (I) Carta di servizio (TR) Servis karti (HU) Szerviz kártya
 (F) Carte de service (NL) Dienst kaart (CZ) Servisni karta (RU) Инструкция по монтажу

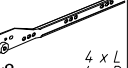
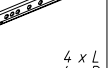
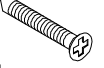
KOLDING KO-11



(A)  x45	(B)  x45	(C)  x26	(D)  x45	(E)  x16	(J)  x3	(K)  x1	(M)  x16	(N)  x22	(R)  x50
(AB)  x8	(CB)  x8	(CN)  x24	(CU)  x8	(CW)  x8	(DB)  x4	(FG)  x6	(ZG)  x4	(ZS)  x4	

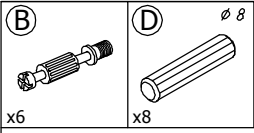

1

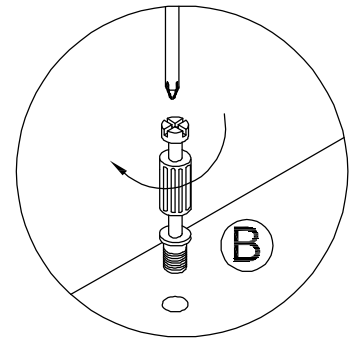
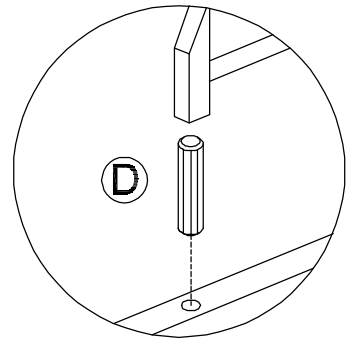
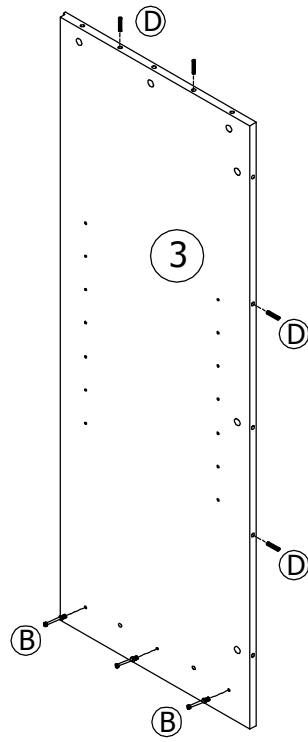
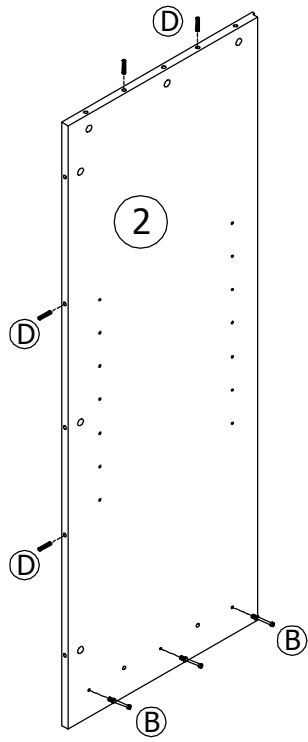

3

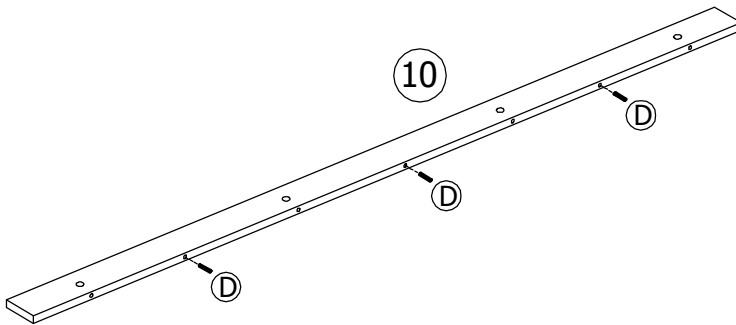
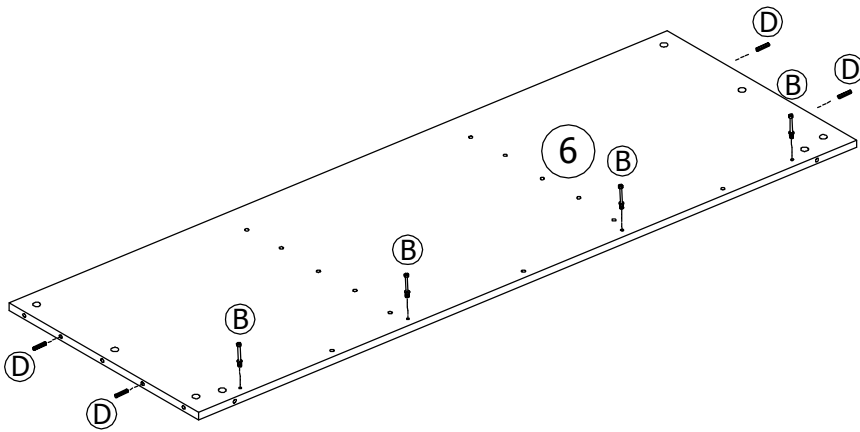
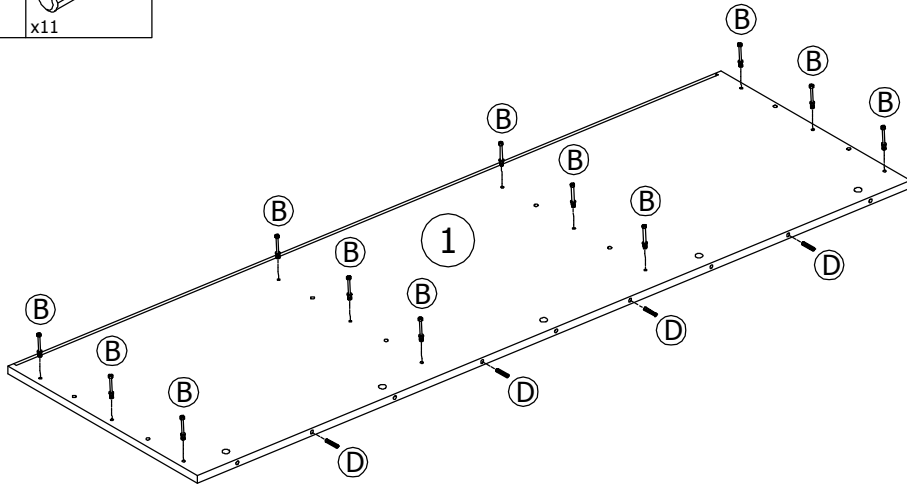
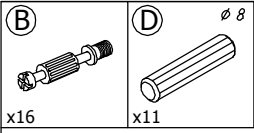

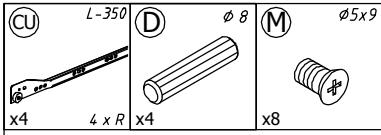

3

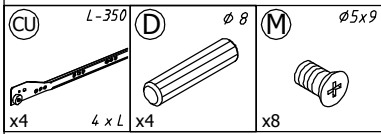
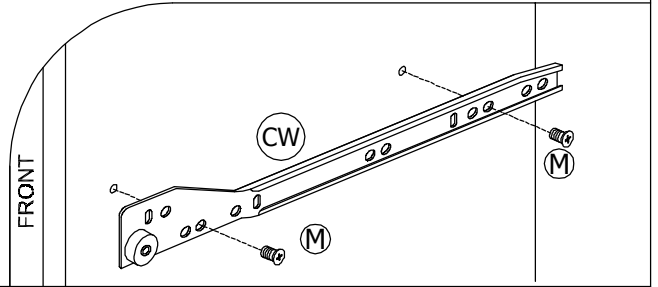
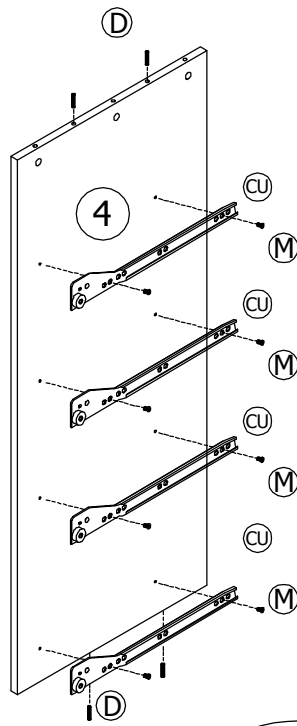

4

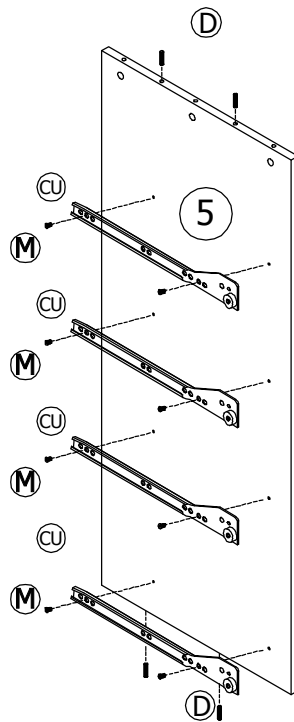

5

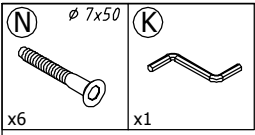

5

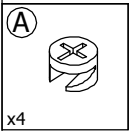
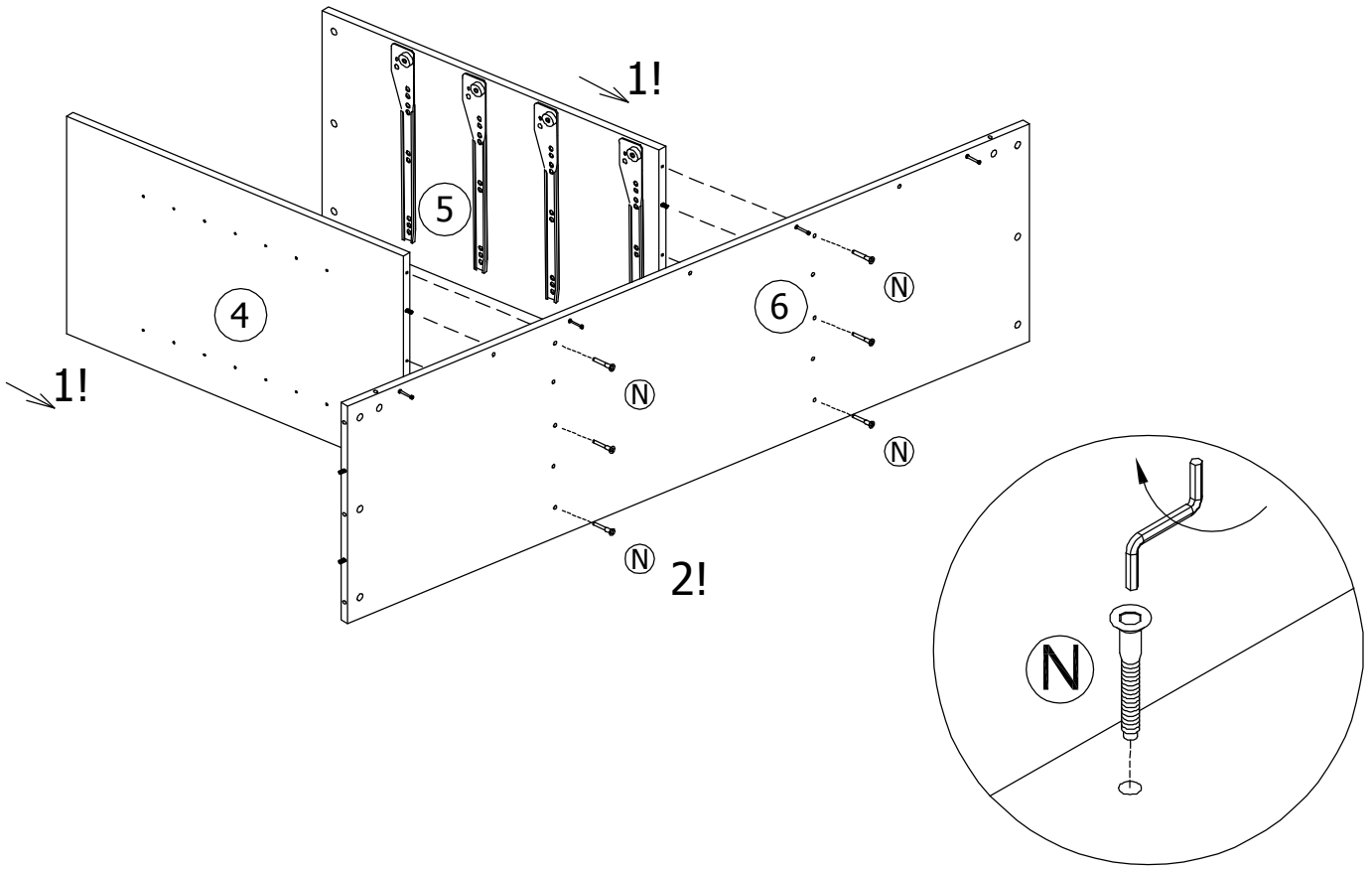

6

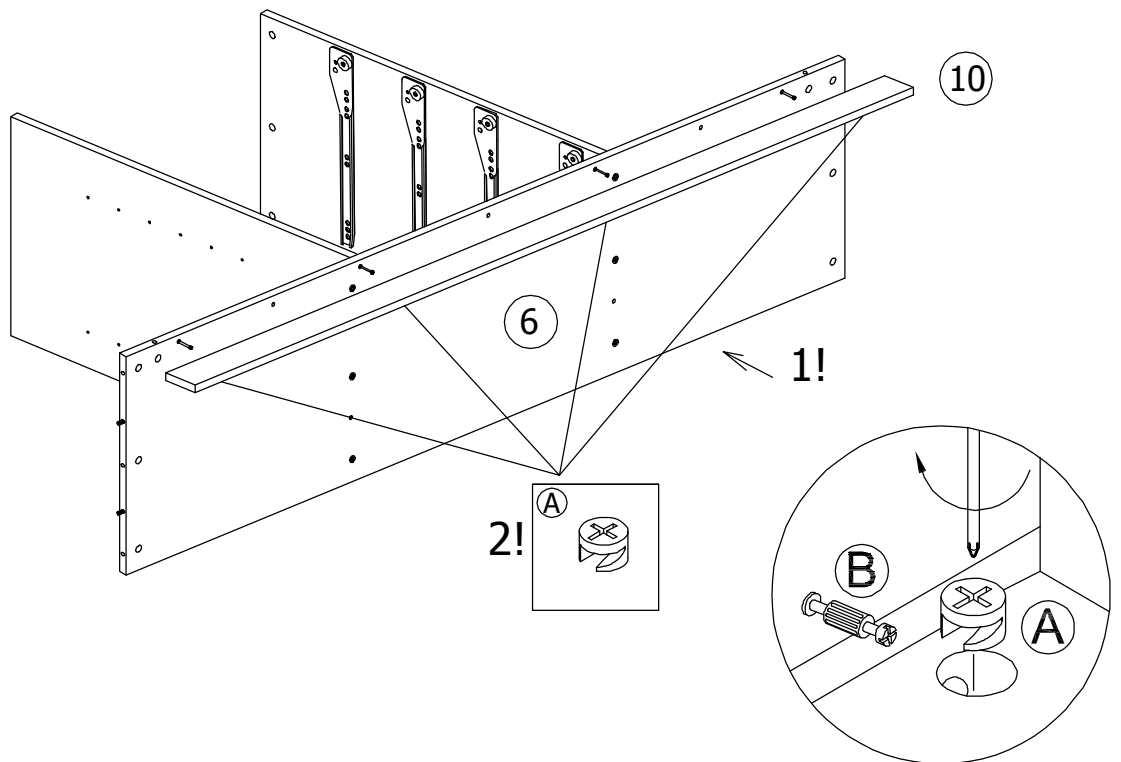

6

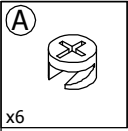

7

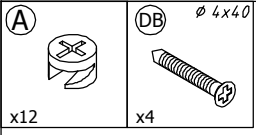
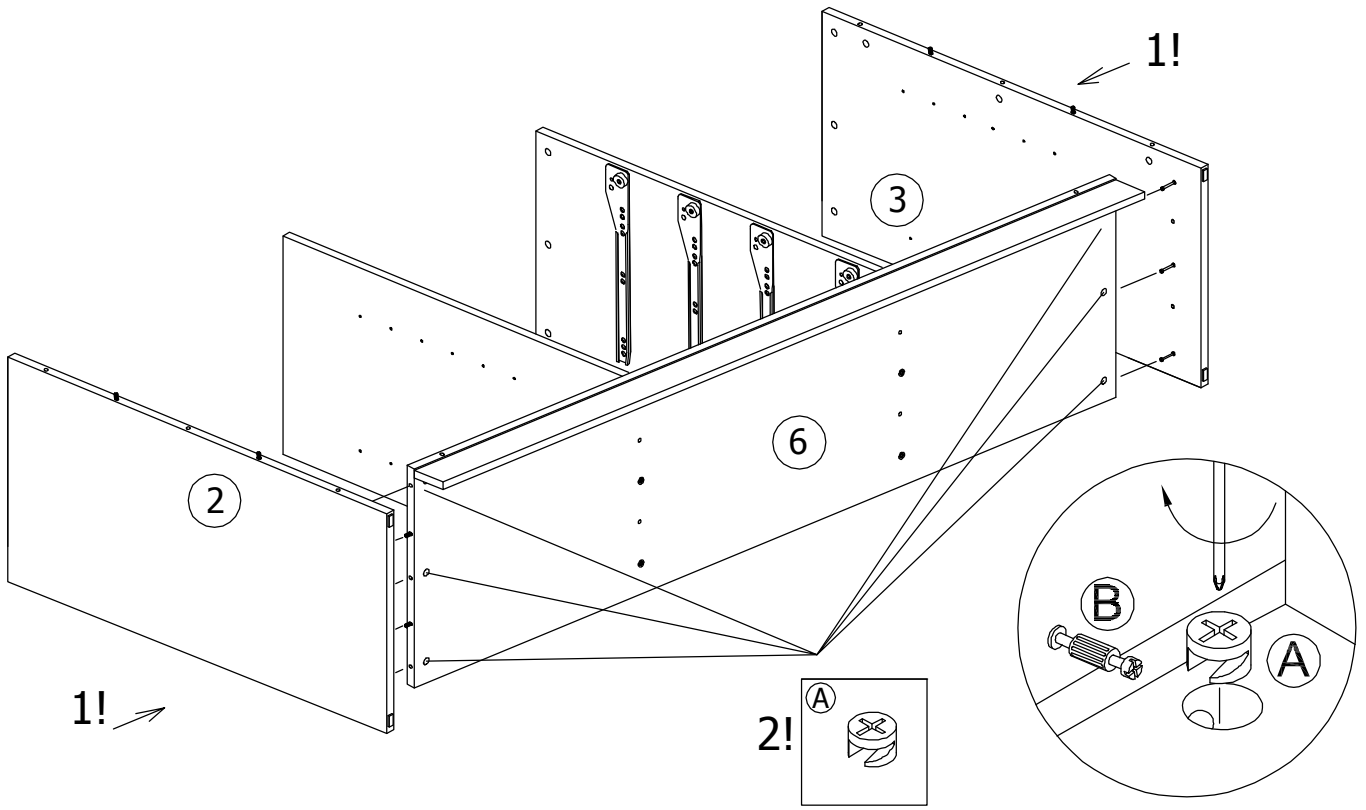

8

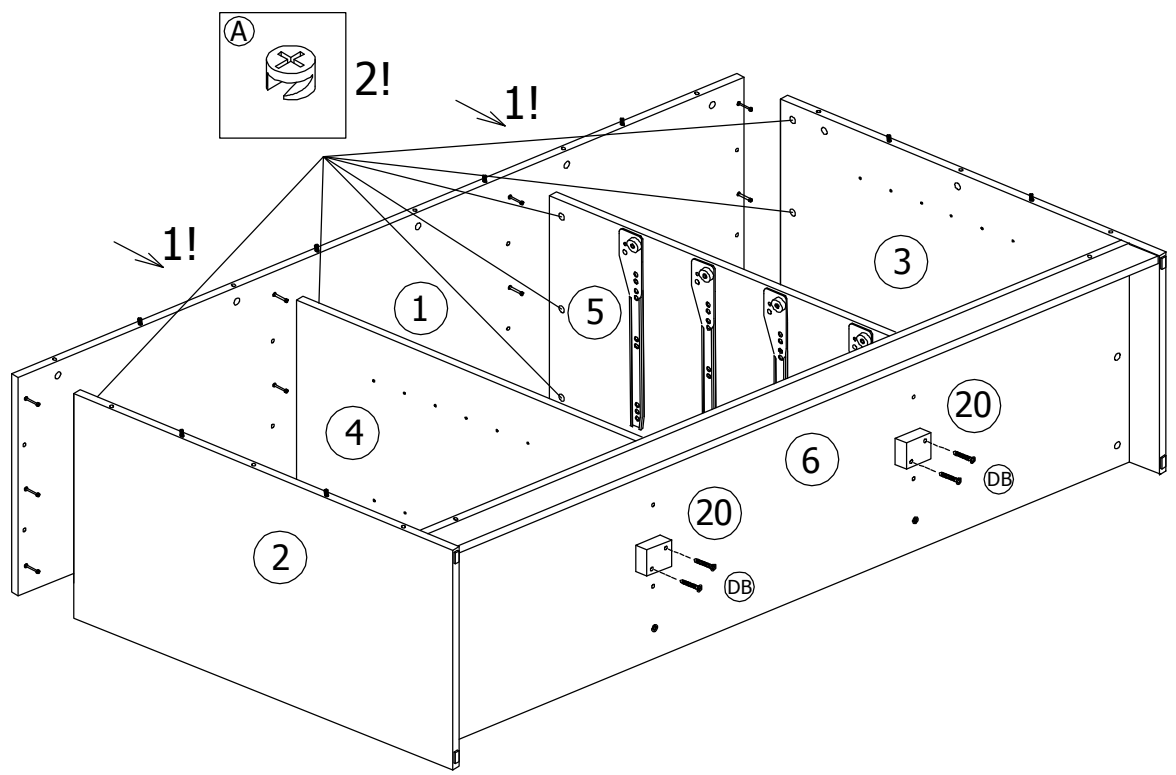

7

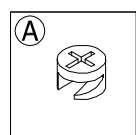
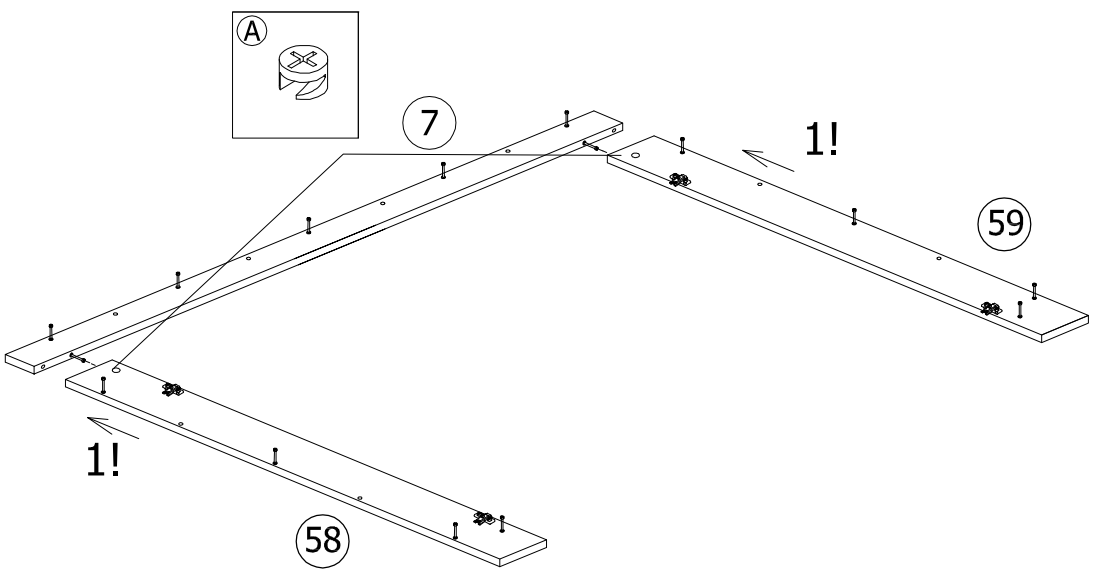
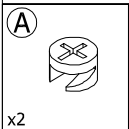
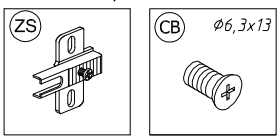
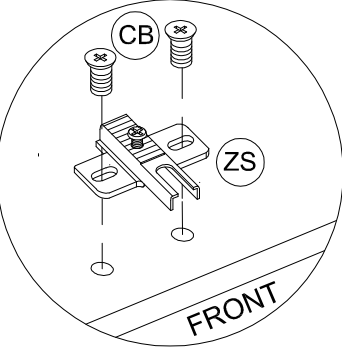
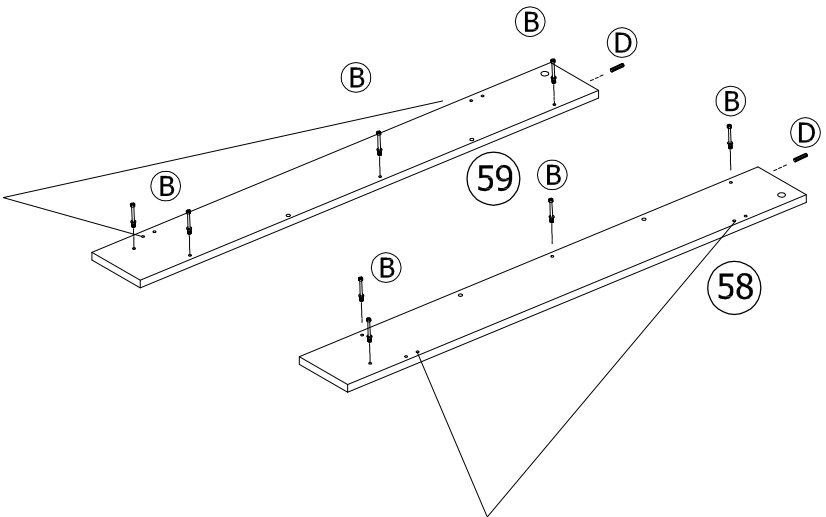
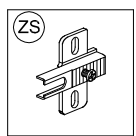
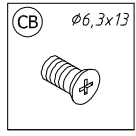
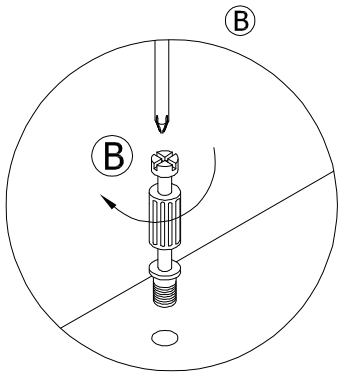
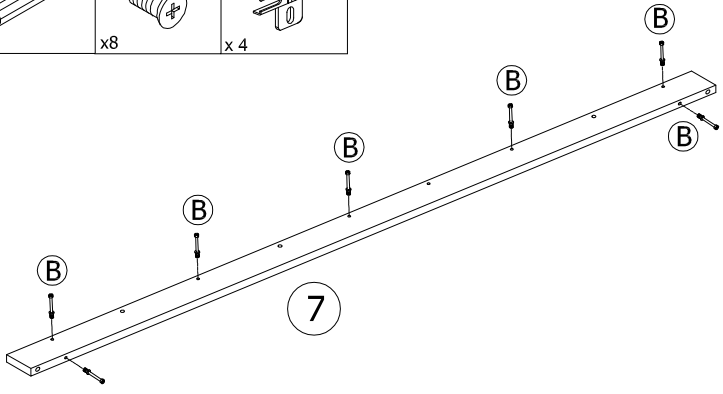
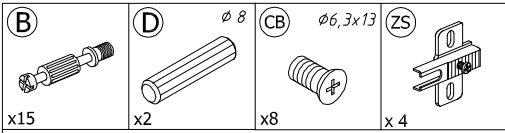

(A)
x13

11

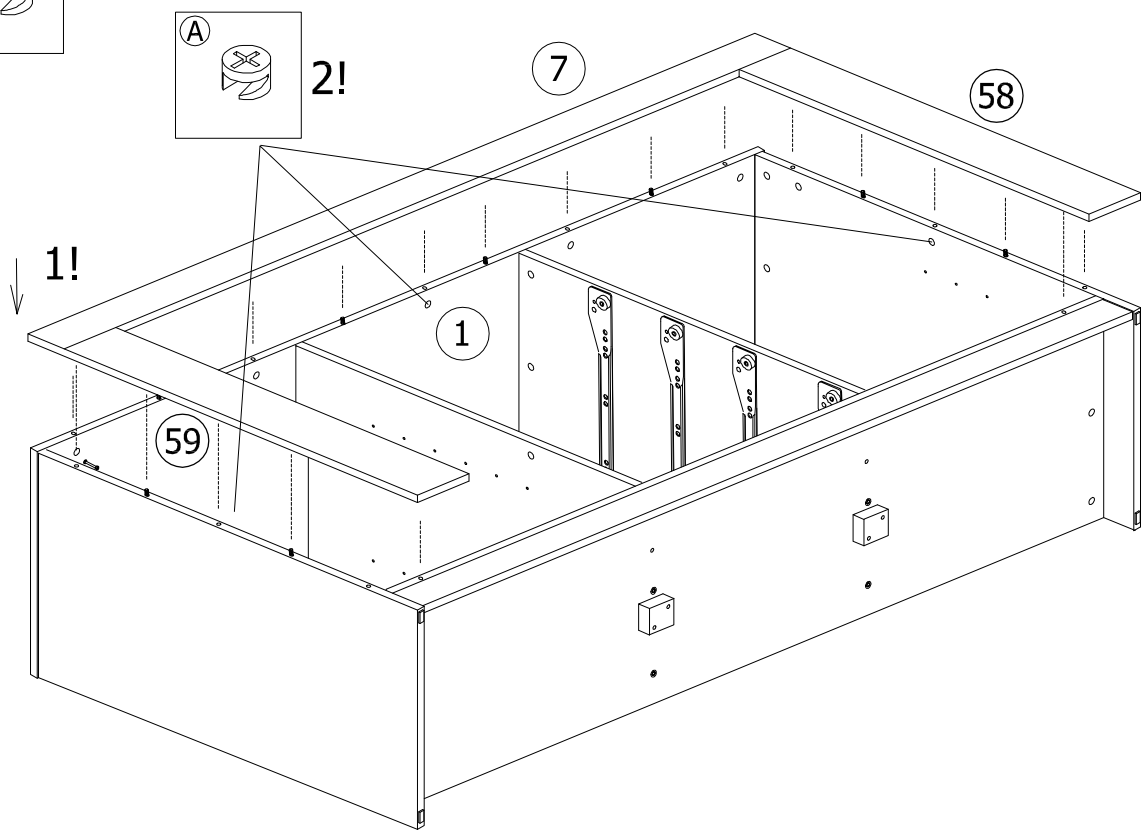

(FG)
x6

12

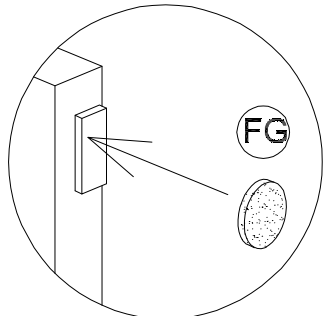
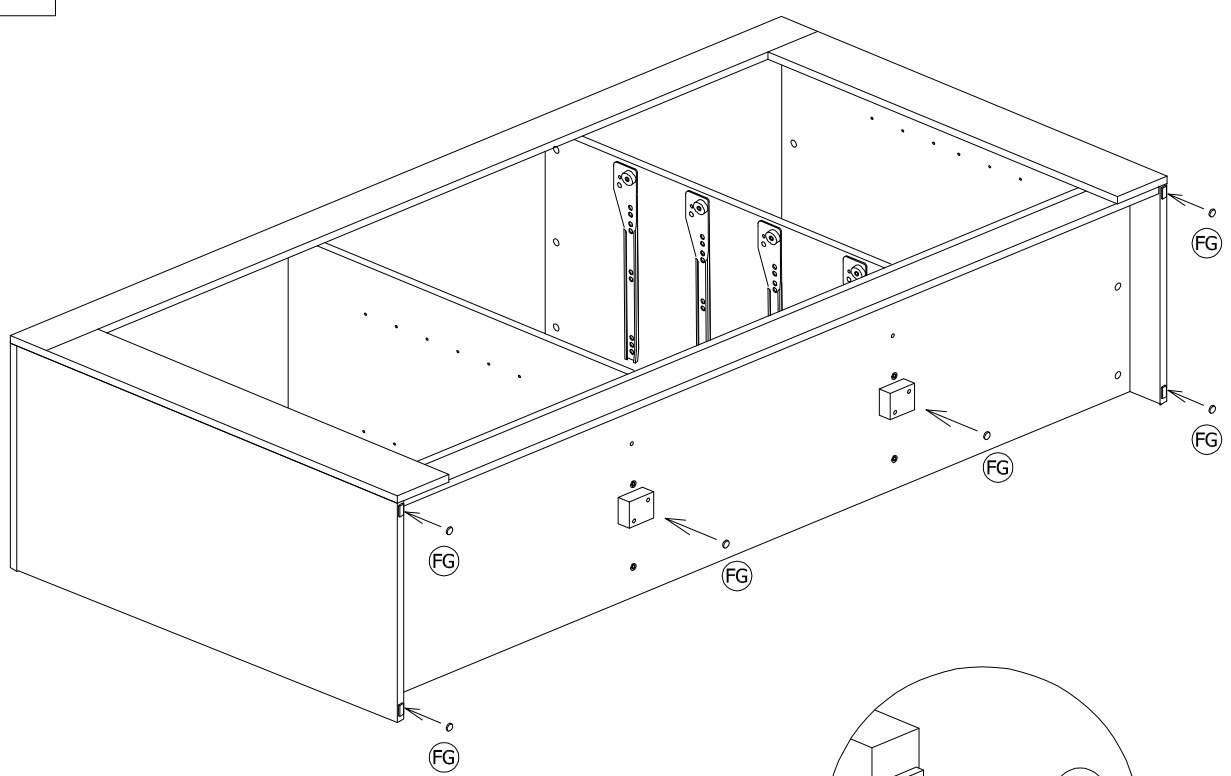

9

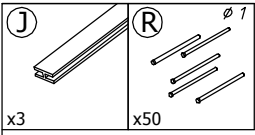

13

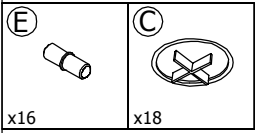
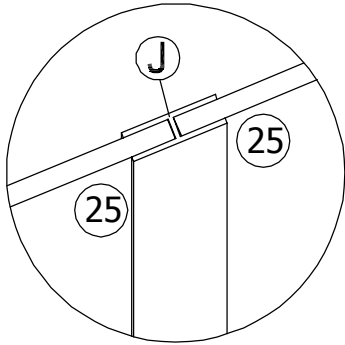
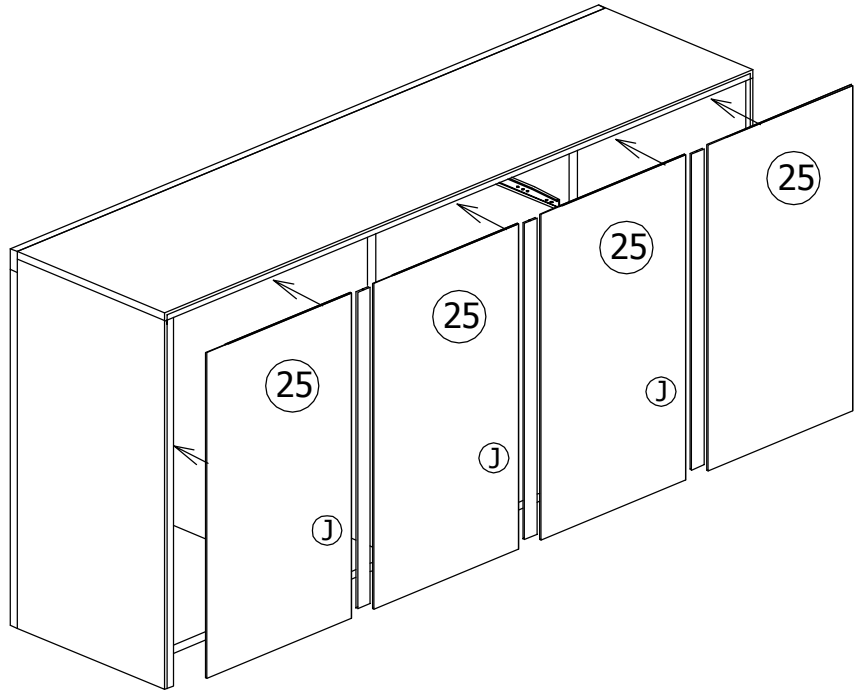
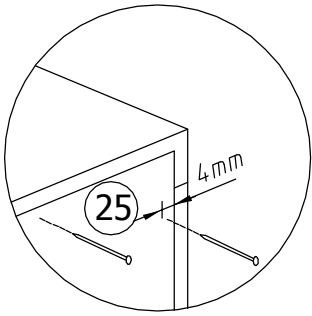

14

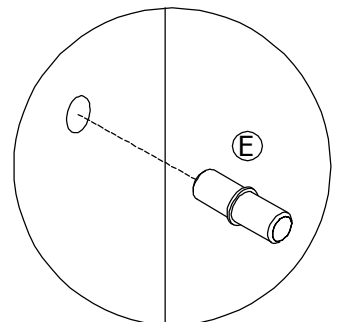
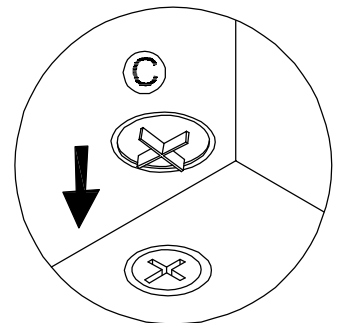
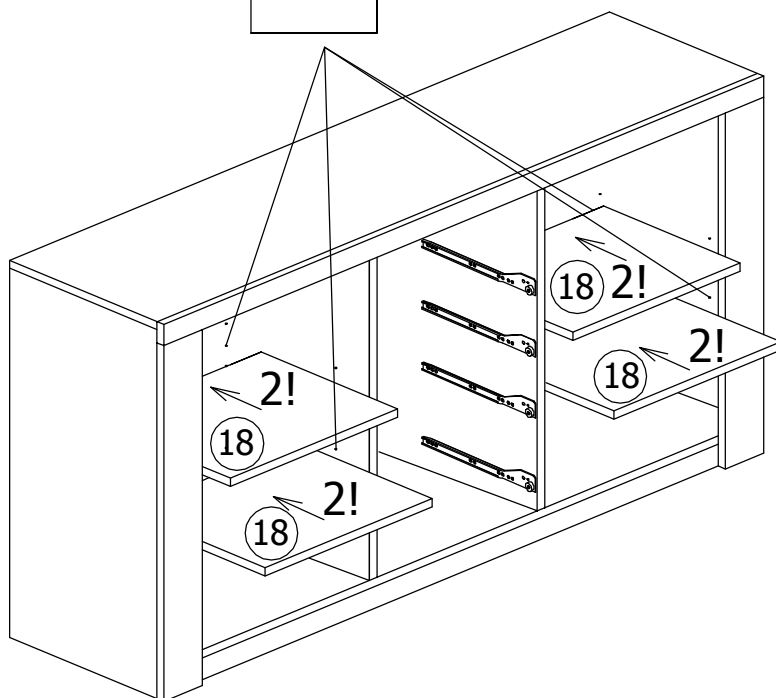
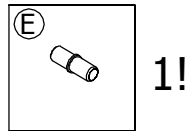

10

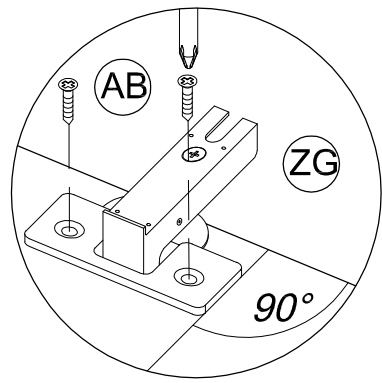
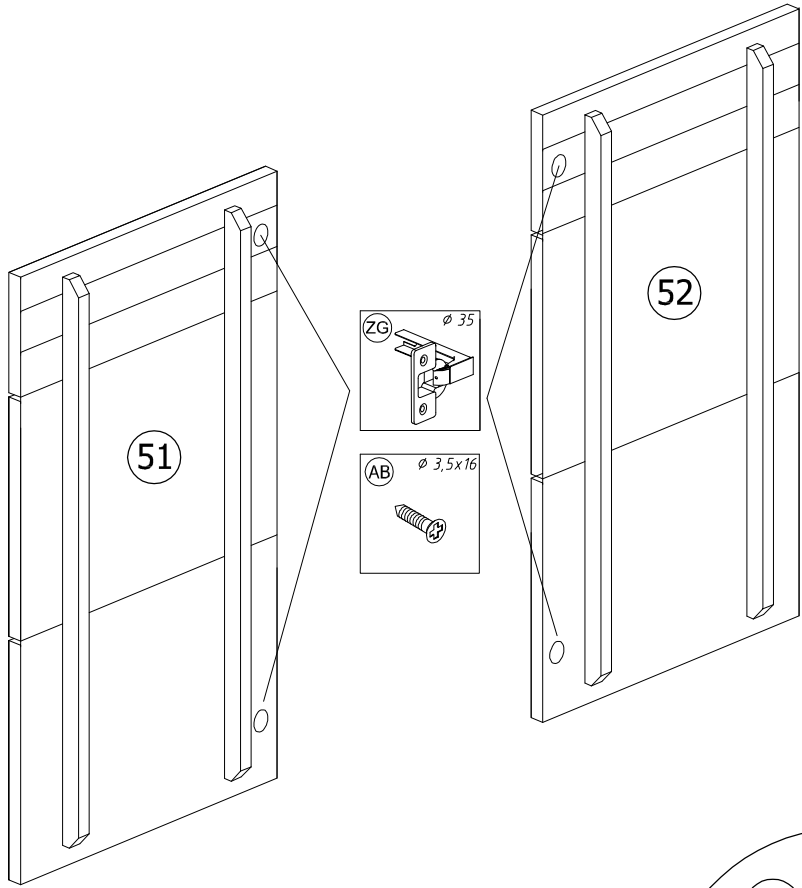
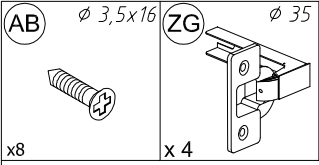

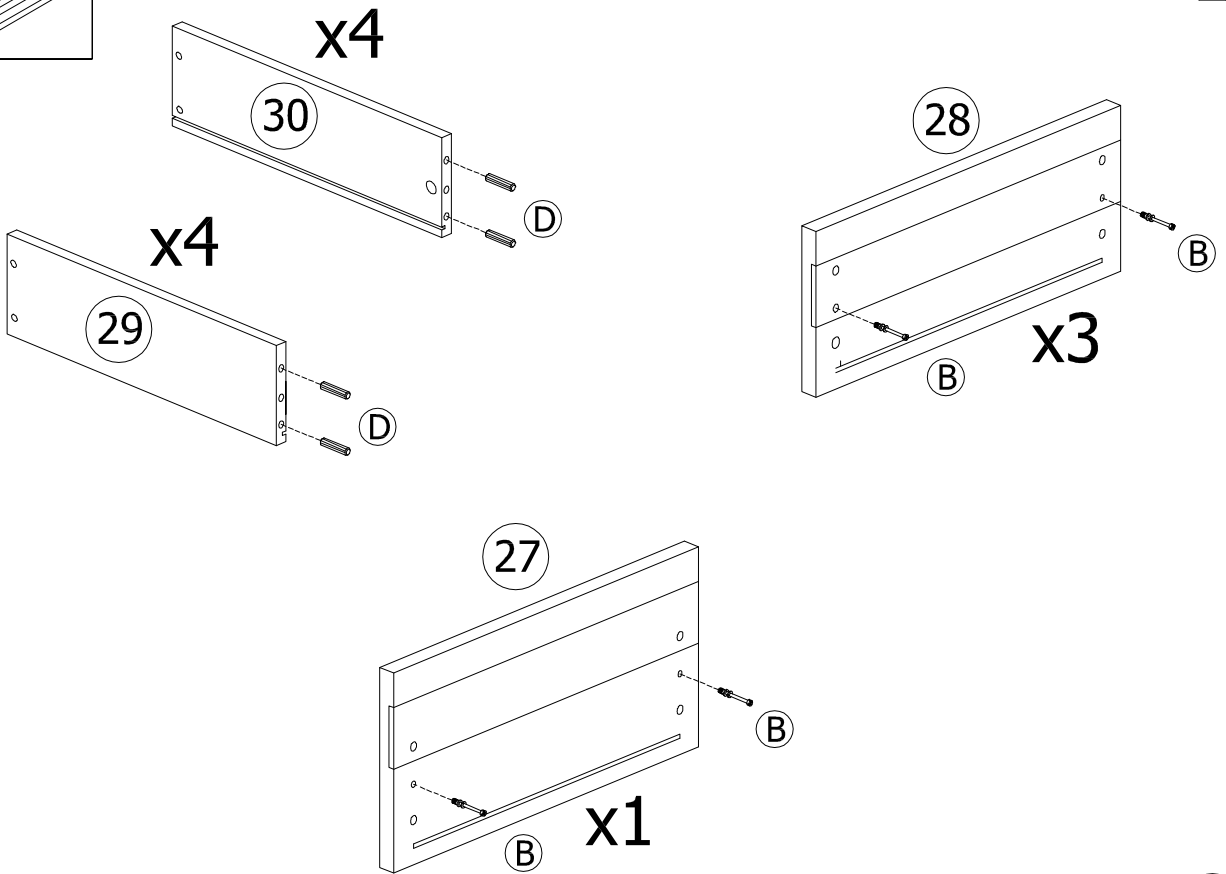
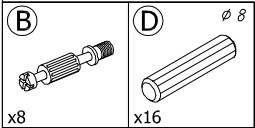
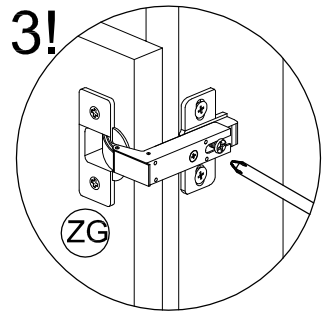
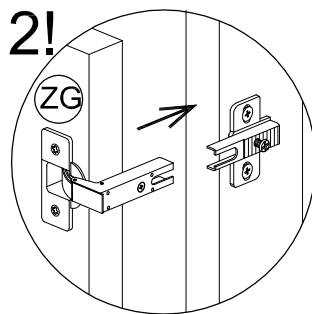
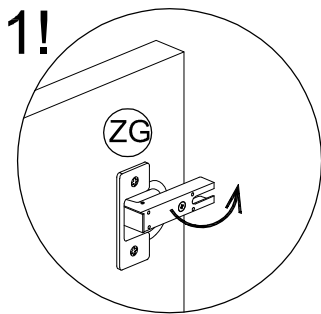
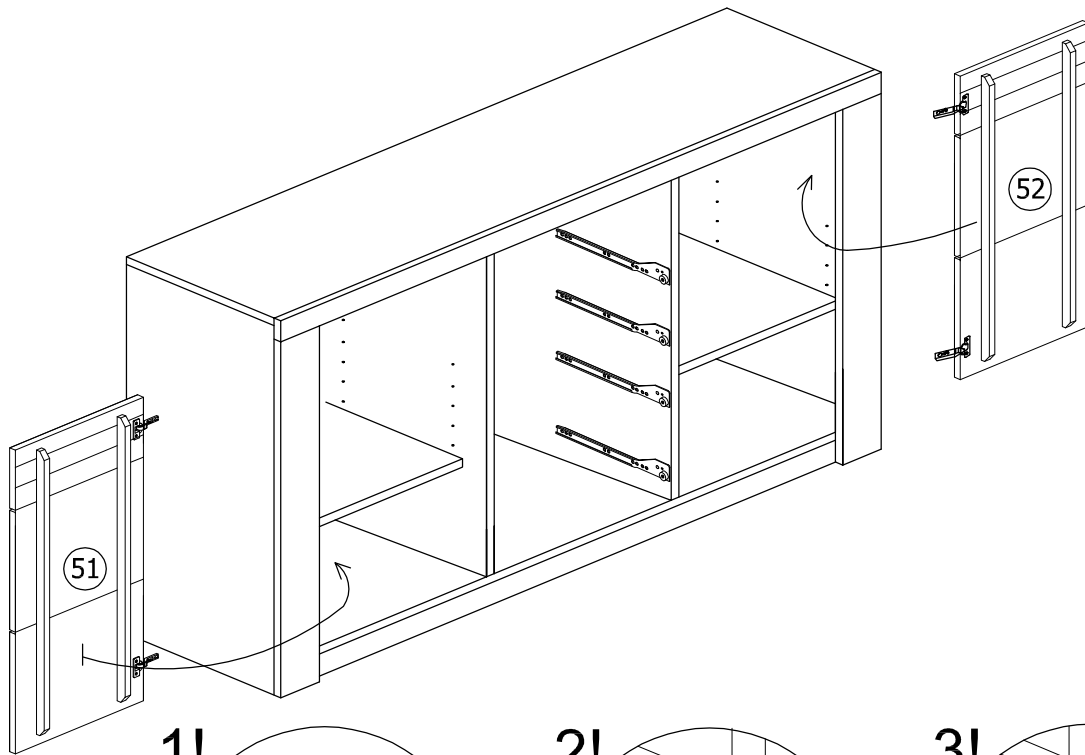

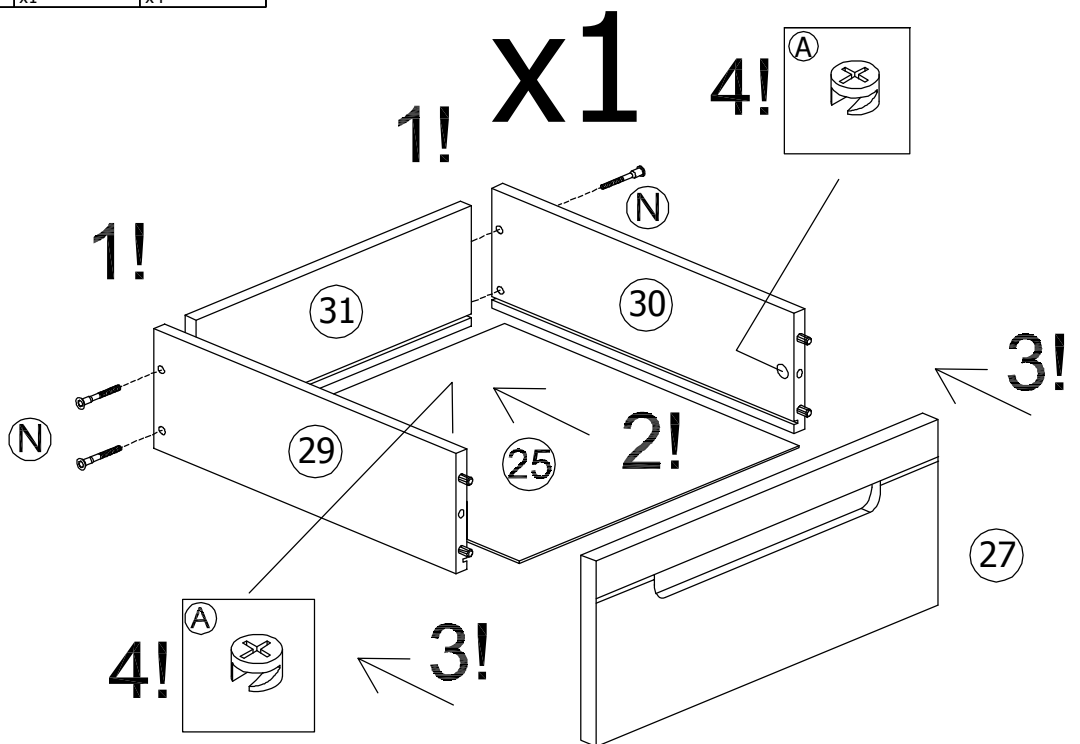
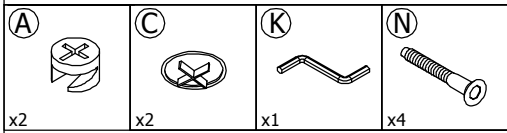
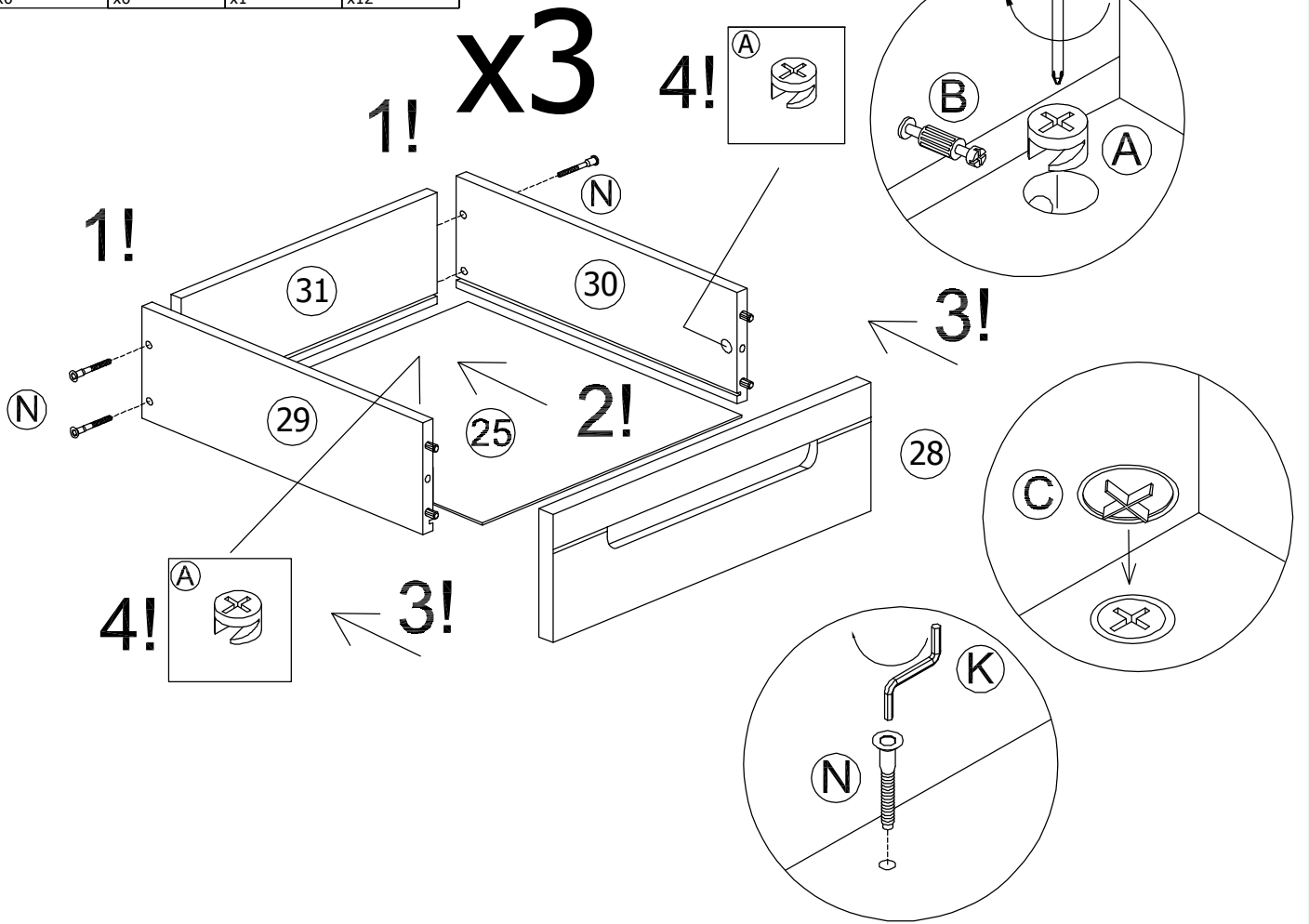
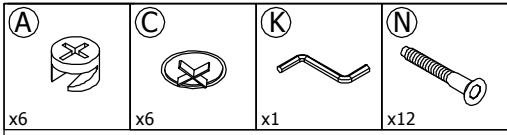

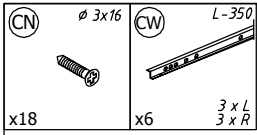

x3

20

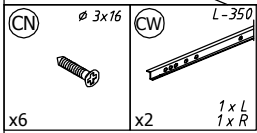
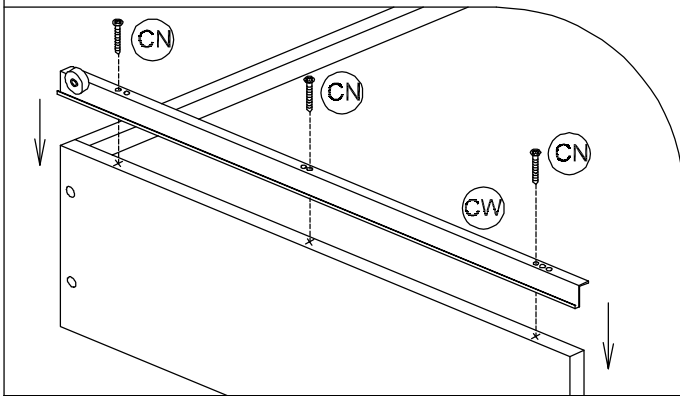
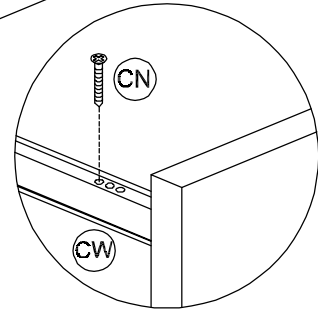
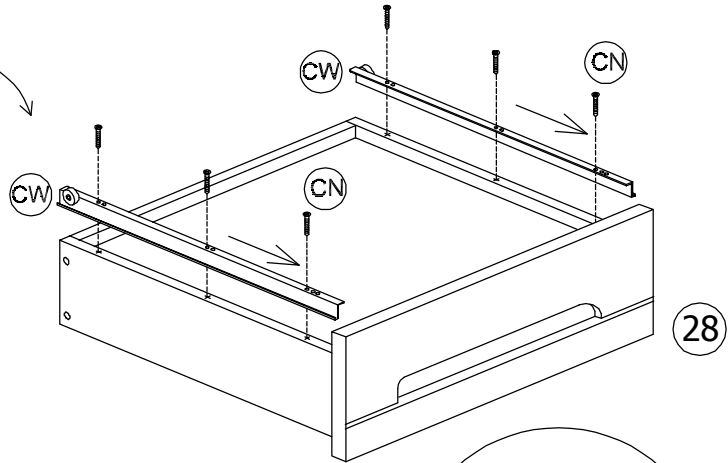
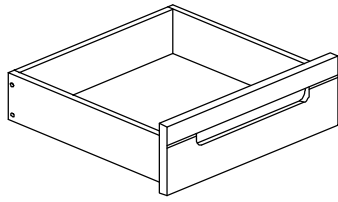

x1

21

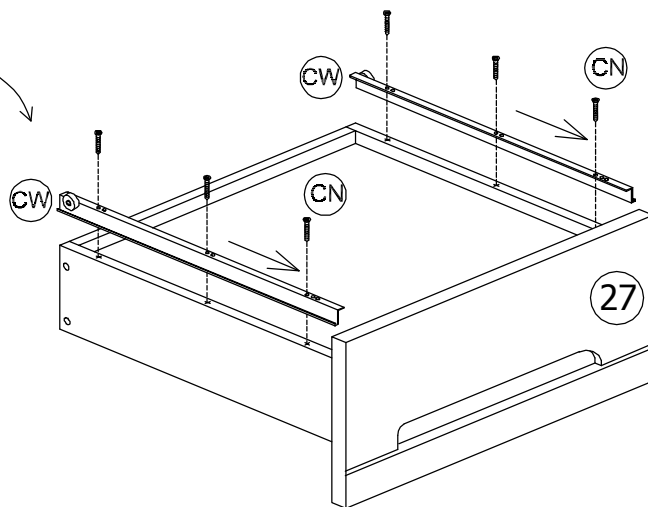
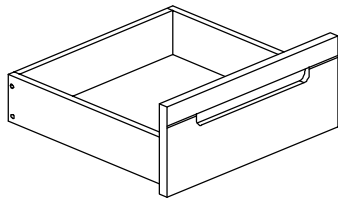

14

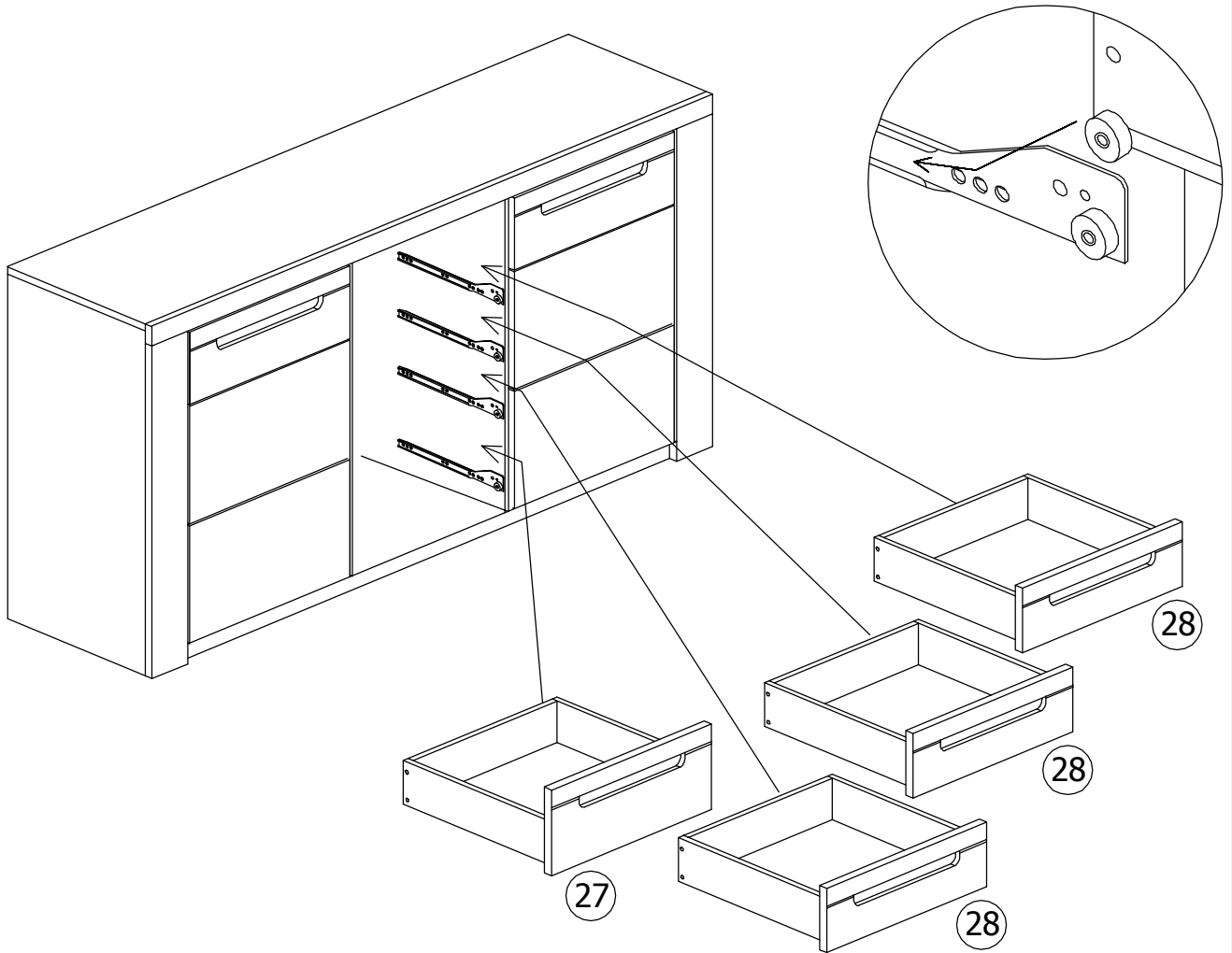

- (D) Turen einstellen (Scharniere justieren)
- (GB) Adjusting the doors (adjusting the hinges)
- (F) Mettre la porte (égaliser les gonds)
- (RO) Ajustați ușa (aliniați balamalele)
- (I) Regolare la porta (livellare le parentesi)
- (NL) Deuren instellen (scharnieren afstellen)
- (PL) Nastawić drzwi (wyrównać zawiasy)
- (TR) Kapıların ayarlanması (menteşelerin seviye ayarı)
- (CZ) Seřidít dveře (vyrovnajete závěsy)
- (SK) Zradíte dvere (vyrovnajte závesy)
- (HU) Állítsa be az ajtó (igazítsa be a zsanérokat)
- (RU) Регулировка дверей (регулировка шарнира)

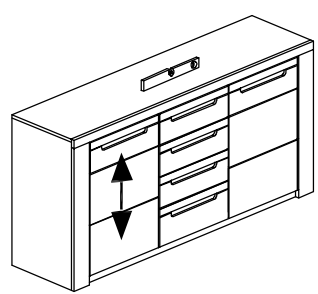

1!

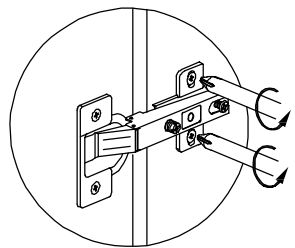

2!

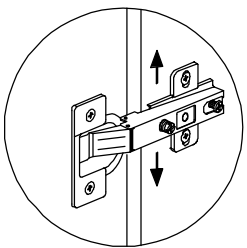

3!

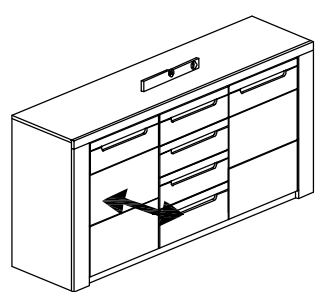
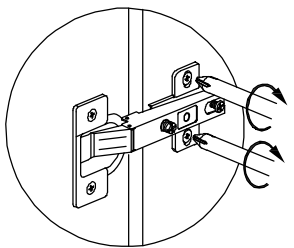

1!

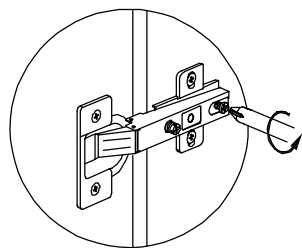

2!

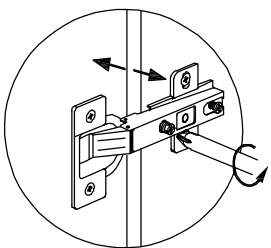

3!

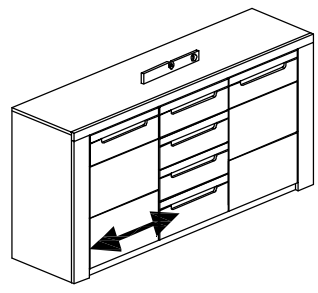
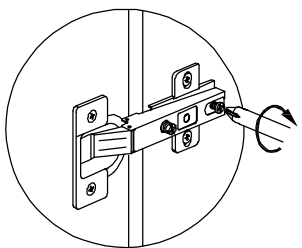

1!

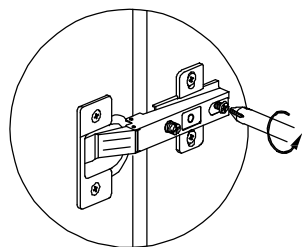

2!

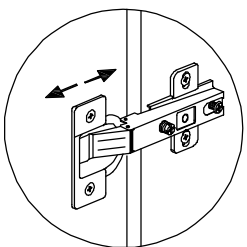

3!

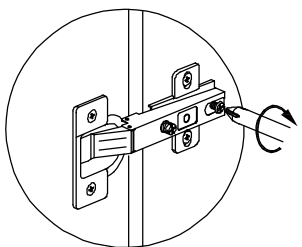

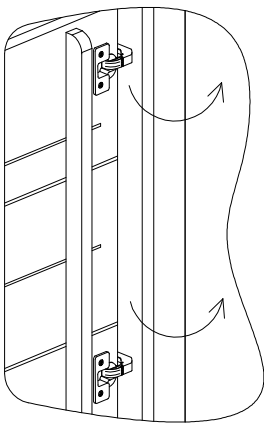
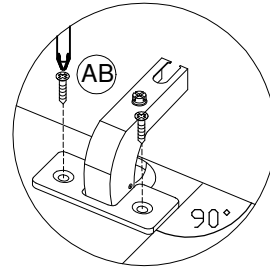
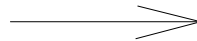
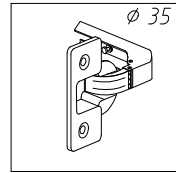
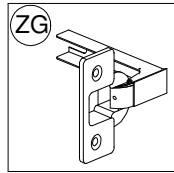
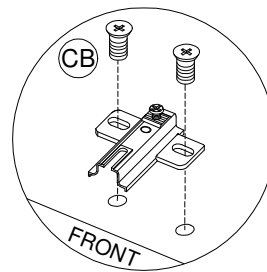
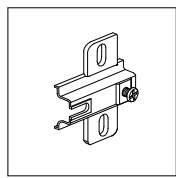
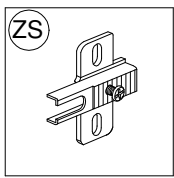

1!

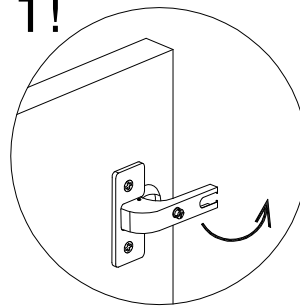

2!

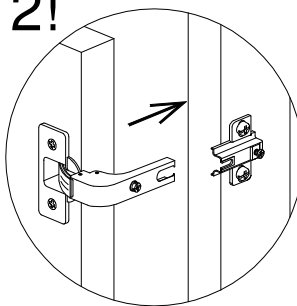

3!

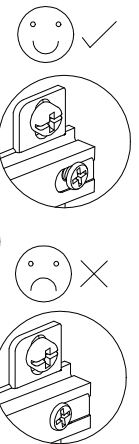
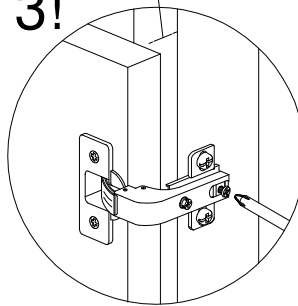

(D) Turen einstellen (Scharniere justieren)

(GB) Adjusting the doors (adjusting the hinges)

(F) Mettre la porte (égaliser les gonds)

(RO) Ajustați ușa (aliniați balamalele)

(PL) Nastawić drzwi (wyrównać zawiasy)

(TR) Kapıların ayarlanması (menteşelerin seviye ayarı)

(CZ) Seřídít dveře (vyrovnajte závěsy)

(SK) Zradít dveře (vyrovnajte závesy)

(I) Regolare la porta (livellare le parentesi)

(NL) Deuren instellen (scharnieren afstellen)

(HU) Állítsa be az ajtó (igazítsa be a zsanérokot)

(RU) Регулировка дверей (регулировка шарнира)

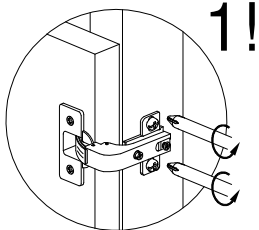

1!

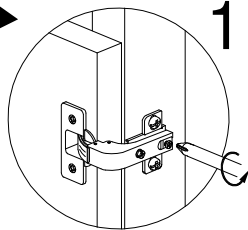

1!

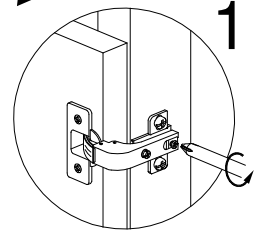

1!

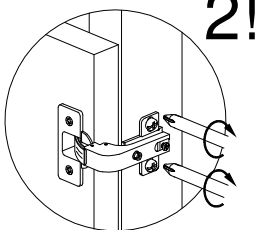

2!

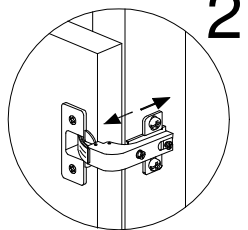

2!

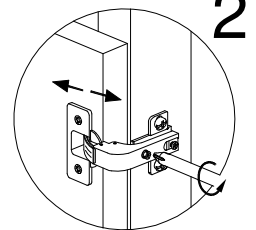

2!

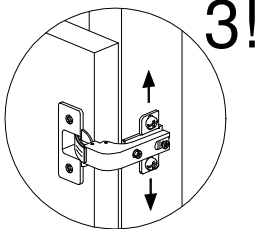

3!

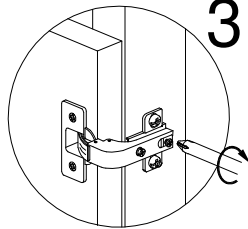

3!

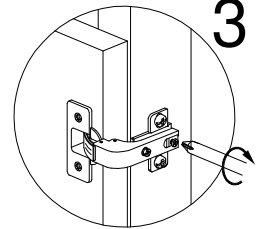

3!