

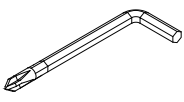

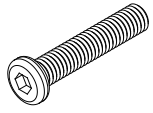
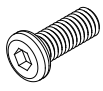

# Assembly Instruction

## HARDWARE LIST

<b>A</b>	<b>B</b>	<b>C</b>	<b>D</b>	<b>E</b>
				
1 PC	12 PCS	4 PCS	2 PCS	2 PCS

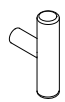
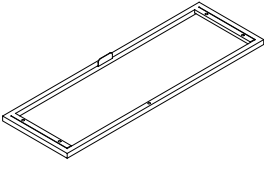
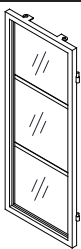
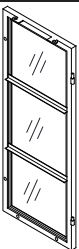
## PART LIST

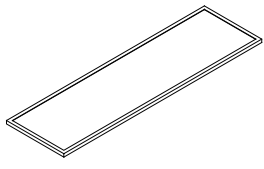
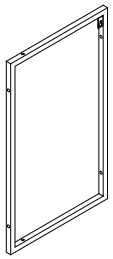
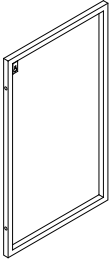
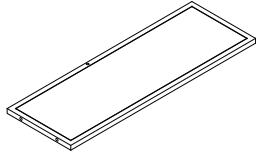
<b>F</b>	<b>G</b>	<b>H</b>	<b>I</b>	<b>J</b>
				
1 PC	1 PC	1 PC	1 PC	1 PC
<b>K</b>	<b>L</b>	<b>M</b>	<b>N</b>	
				
2 PCS	1 PC	1 PC	1 PC	

**IMPORTANT NOTE: DO NOT tighten all screws and bolts until completely assembled**

## Step 1

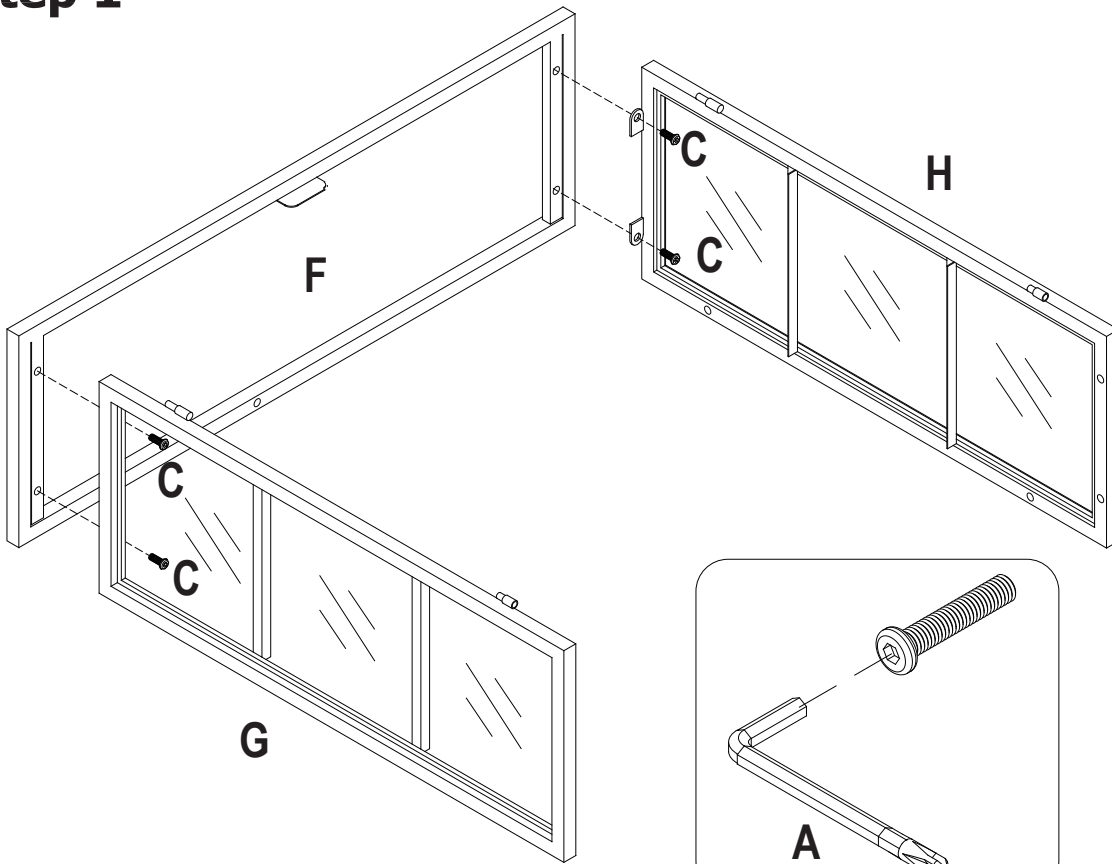

**A X 1 PC**  
**C X 4 PCS**

## Step 2

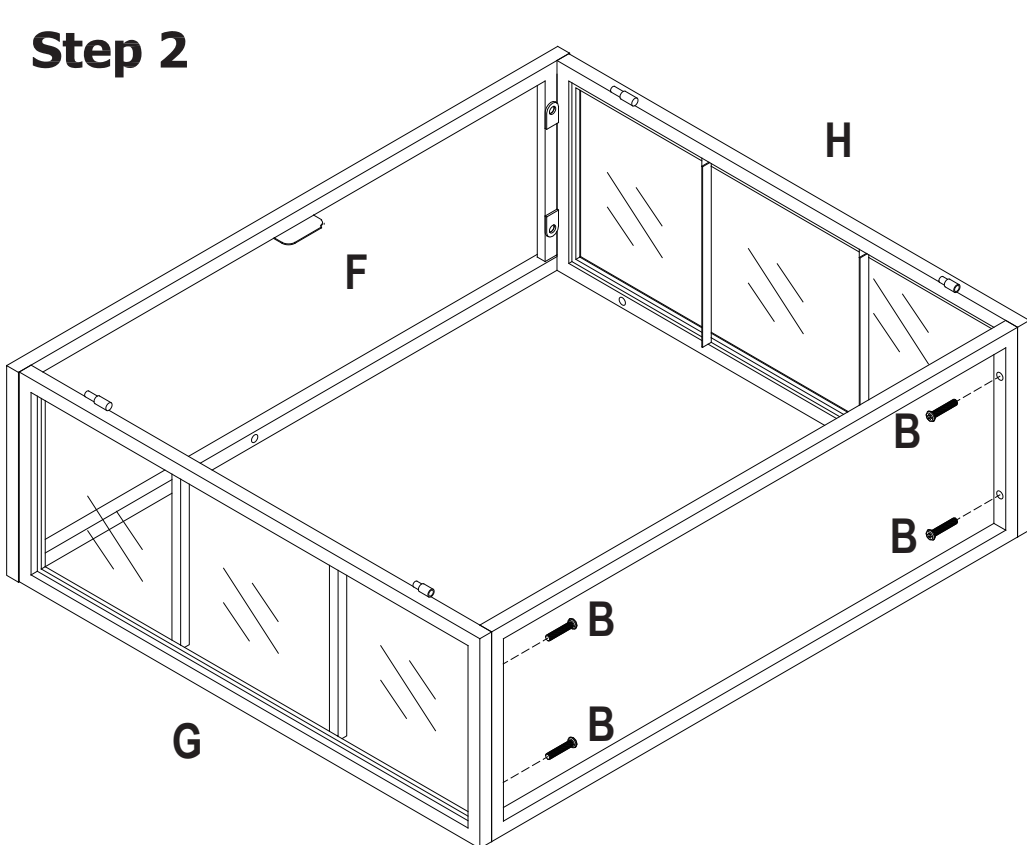

**B X 4 PCS**

### Step 3

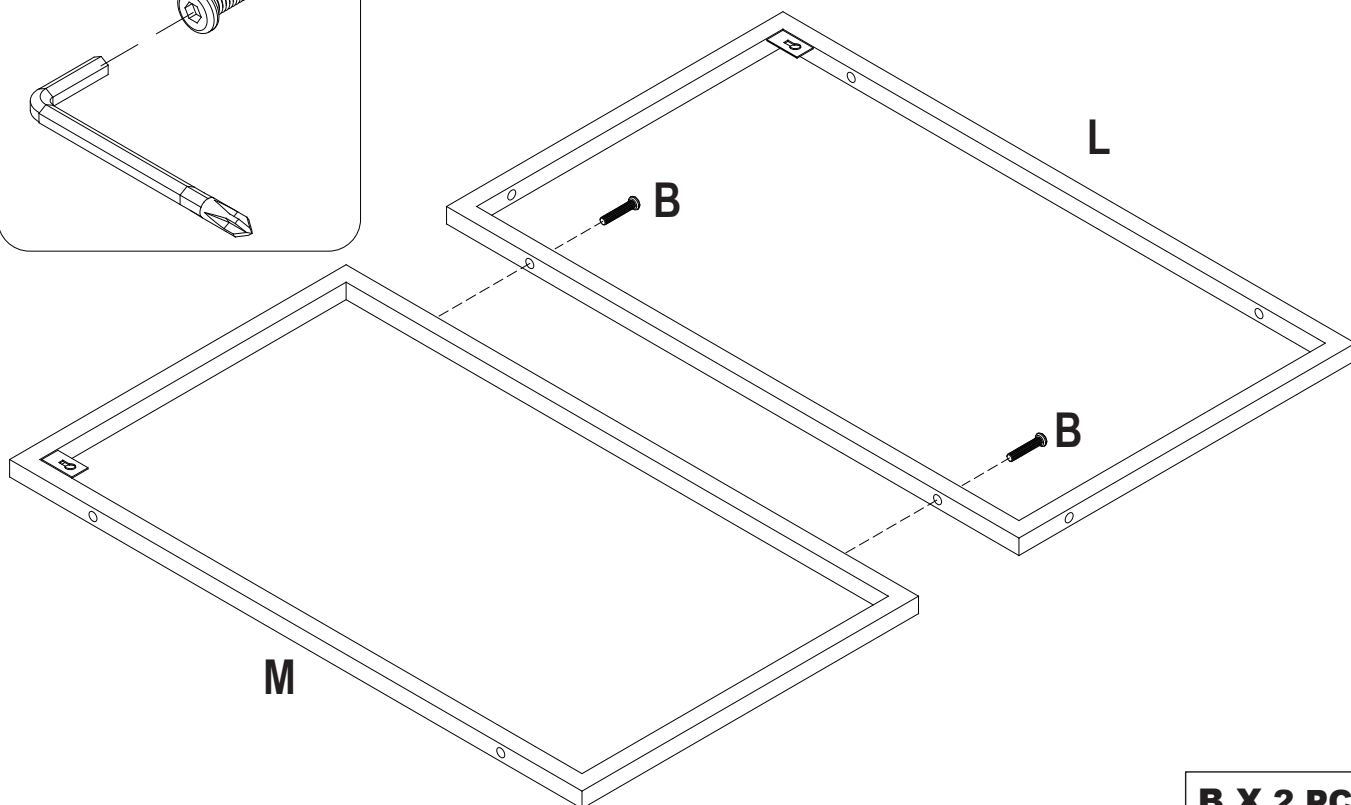
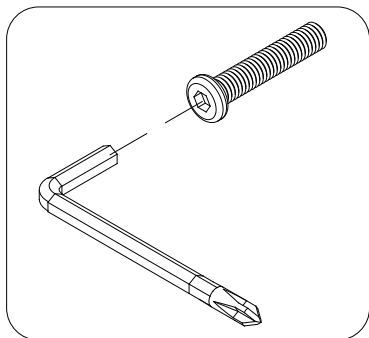

**B X 2 PCS**

### Step 4

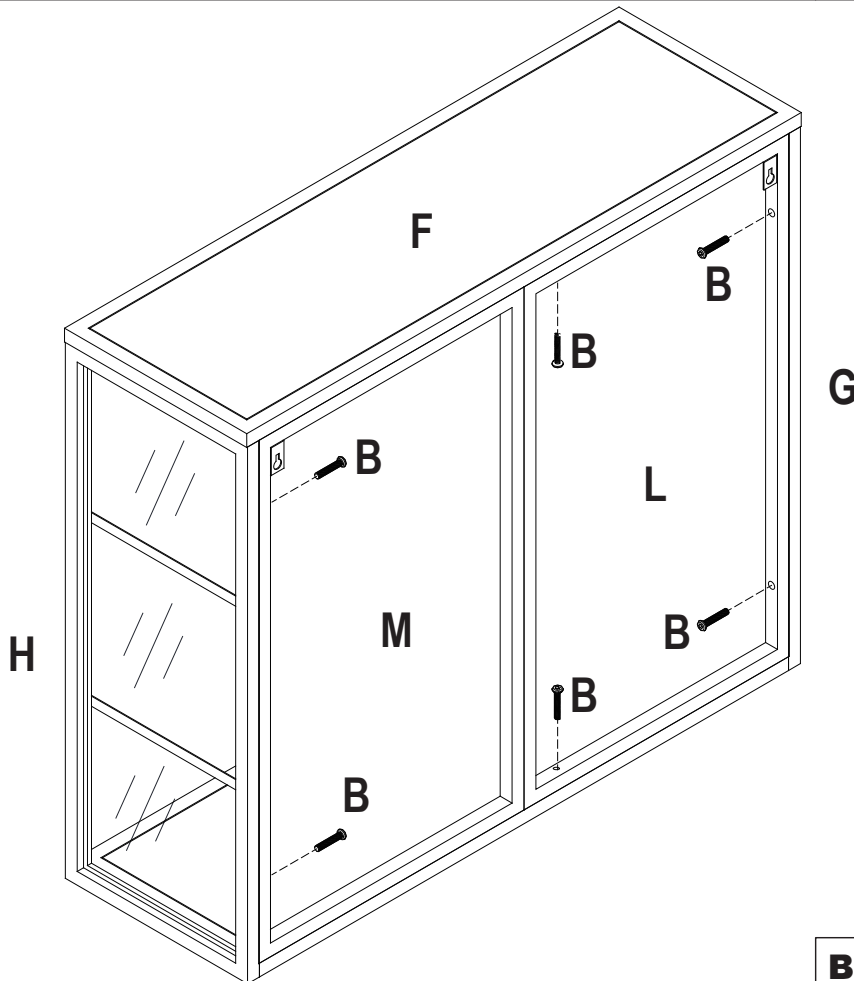
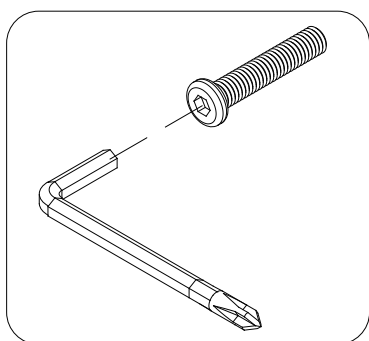

**B X 6 PCS**

## Step 5

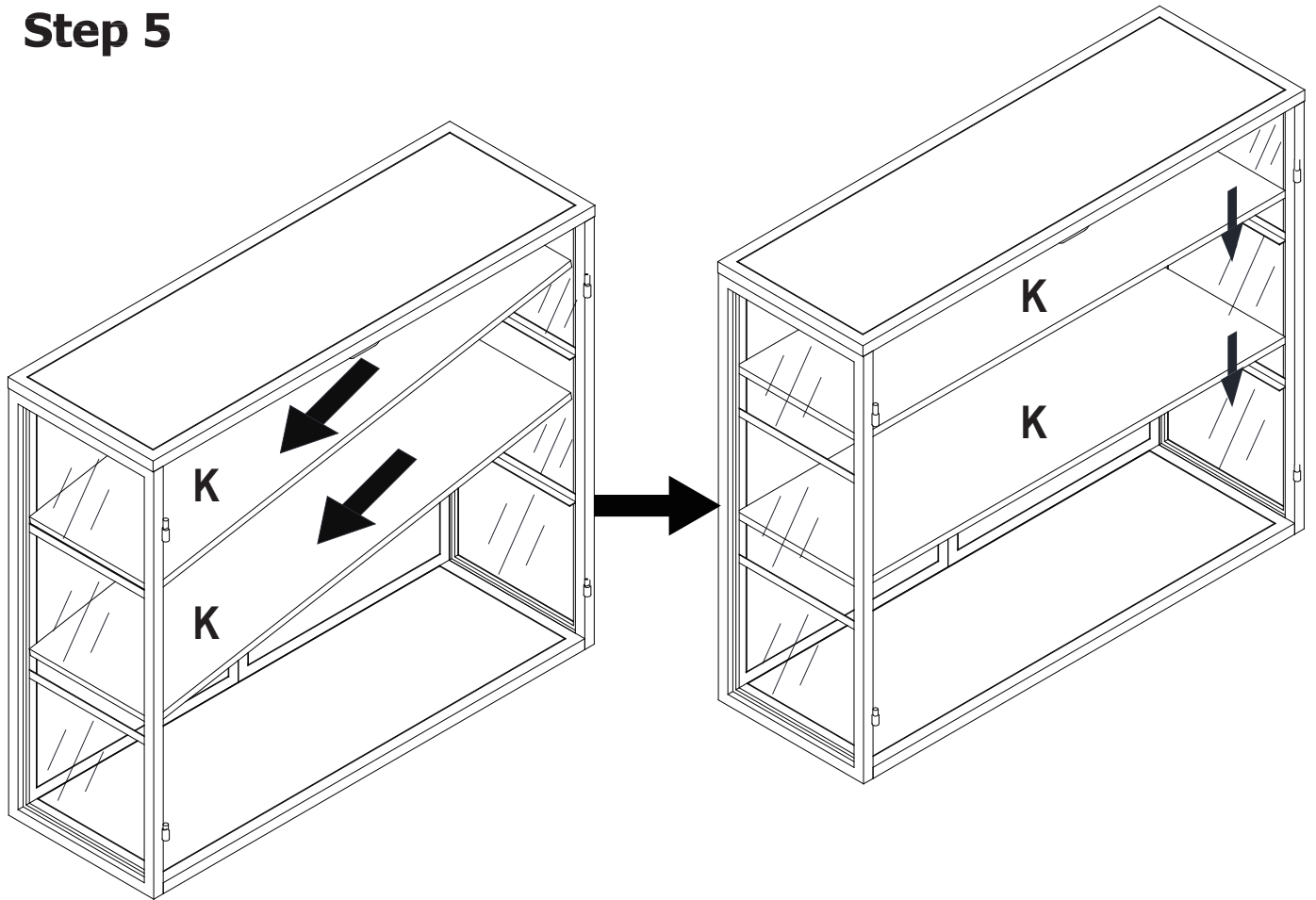

## Step 6

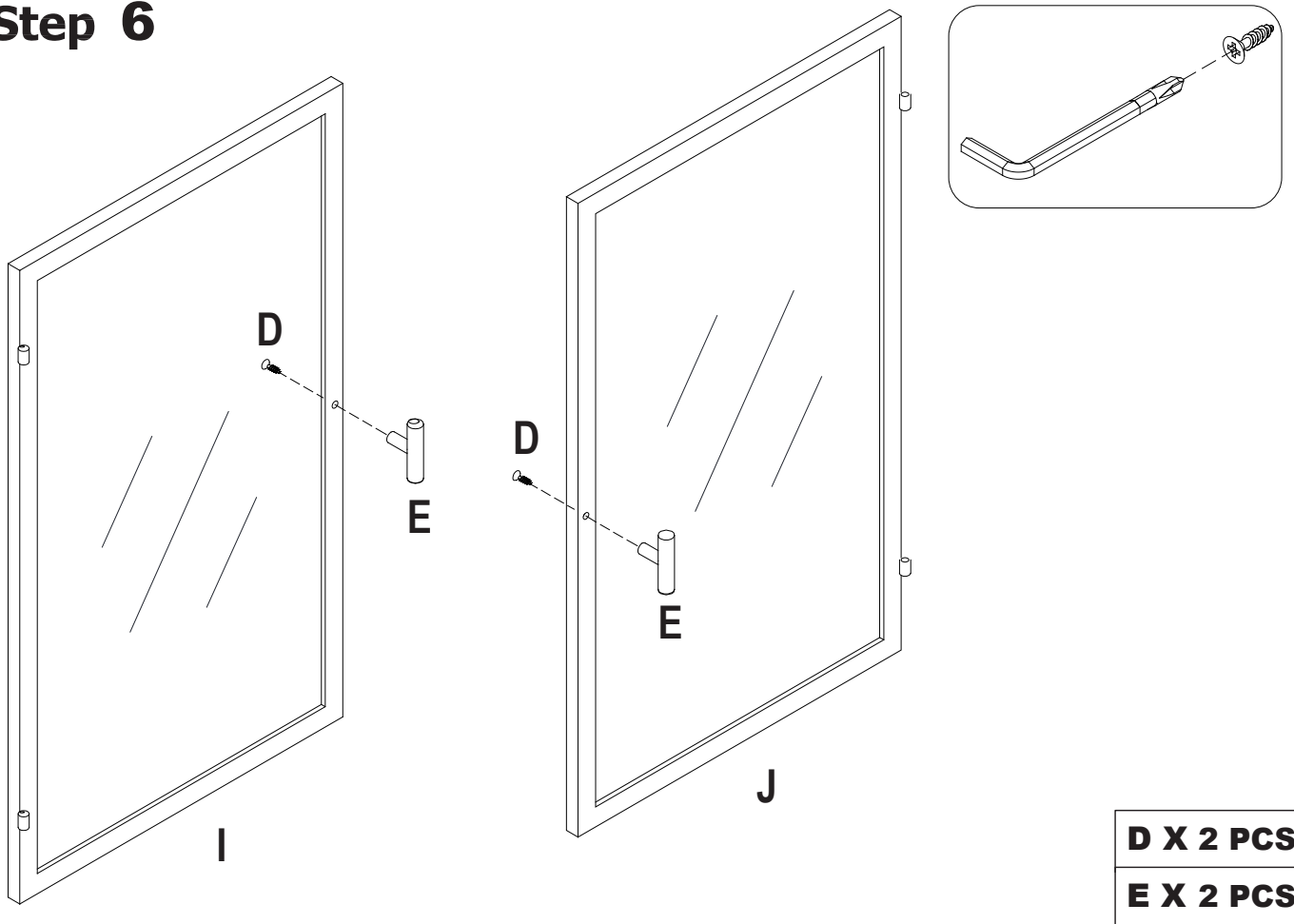

## Step 7

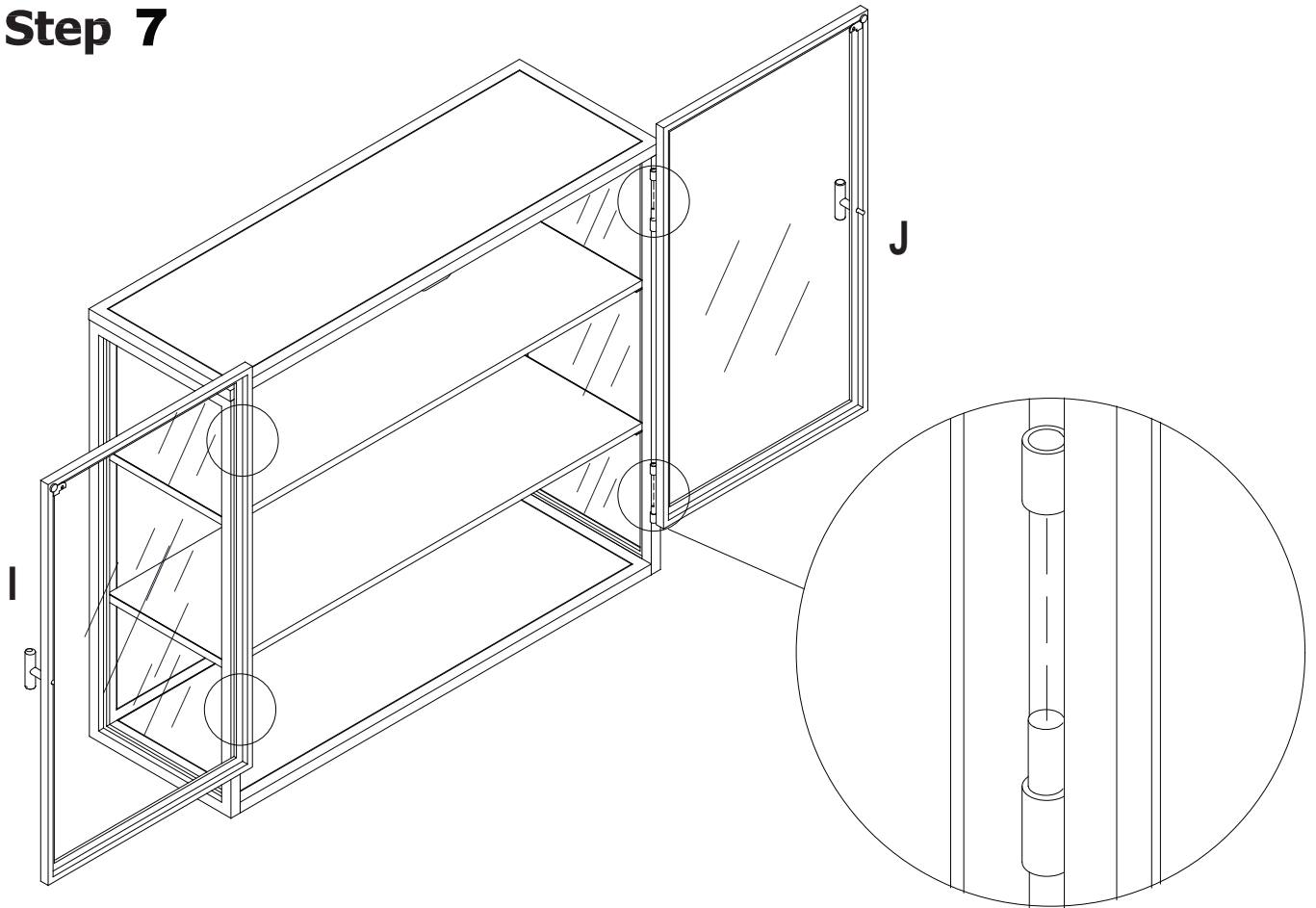

## Step 8

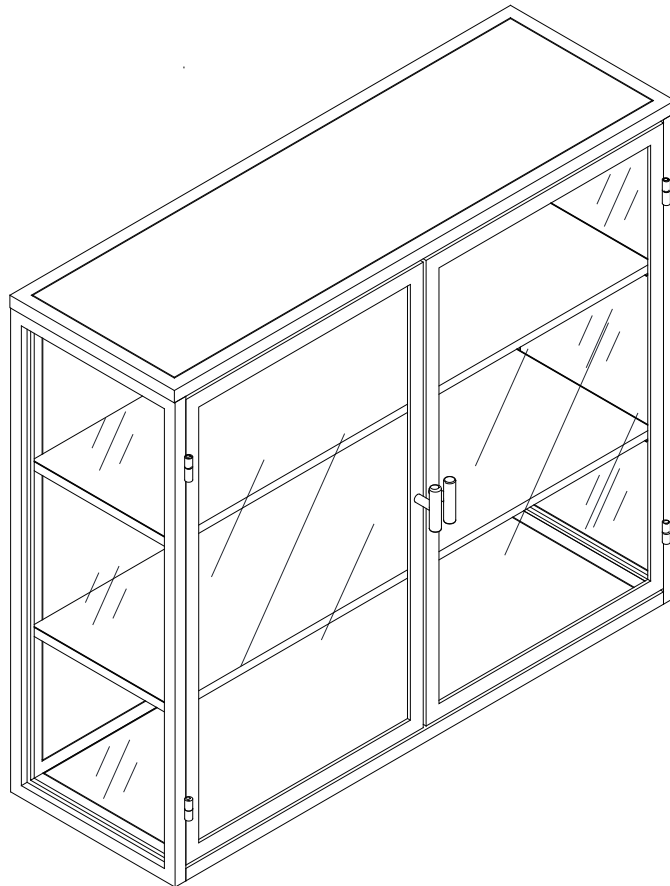

**NOTE: AFTER ASSEMBLY, PLEASE MAKE SURE THAT ALL SCREWS ARE 100% LOCKED**

# Step 9

①

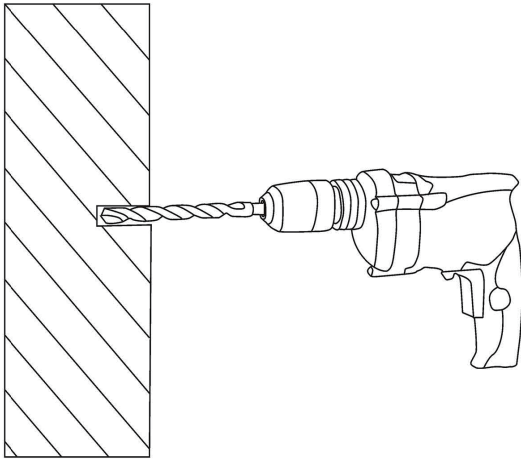

②

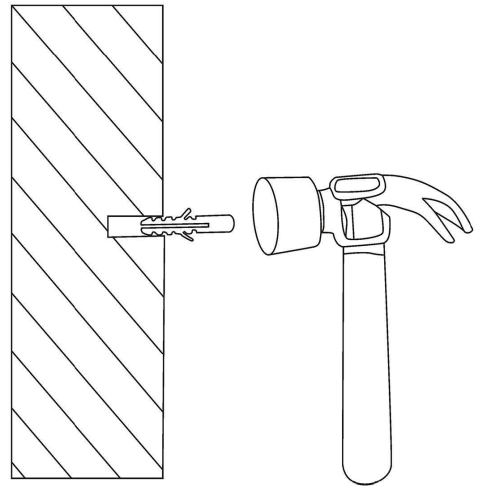

③

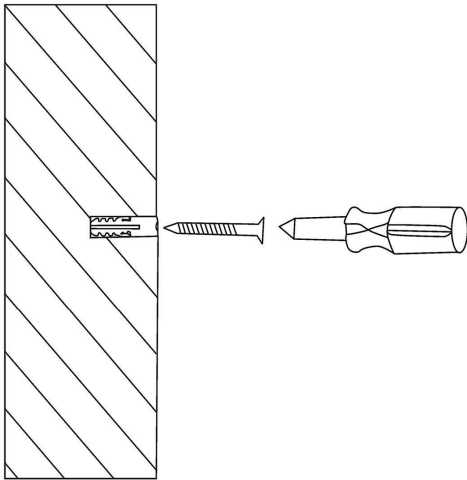

④

