

LKZ: 80262

Modellname/Model name/Nom du modèle/Modellnamn
 Nome modello/Názew modelu/Modelnaam/Ime
 modelu/Numéro Modello/Modell neve/Название
 модели/Názov modelu/Ime modela/Denumire
 model/Наименование на модела/Nazwa modelu

ECHO

Modellnummer/Number/Numéro du modèle
 Numero/Номер на модела/modello
 Číslo modelu/Modell száma/Ďíslo modelu
 Številka modela/Număr model/Broj modela
 Modelnummer/Numer modelu

1913-644-00 □

Туре/Типо/Tipus/Тур/Тип/Tip

644

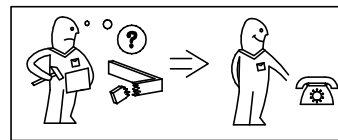
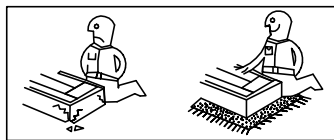
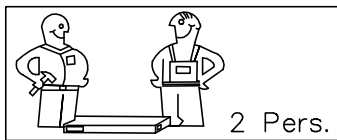
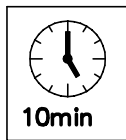
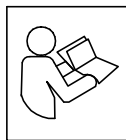

1913-862-92

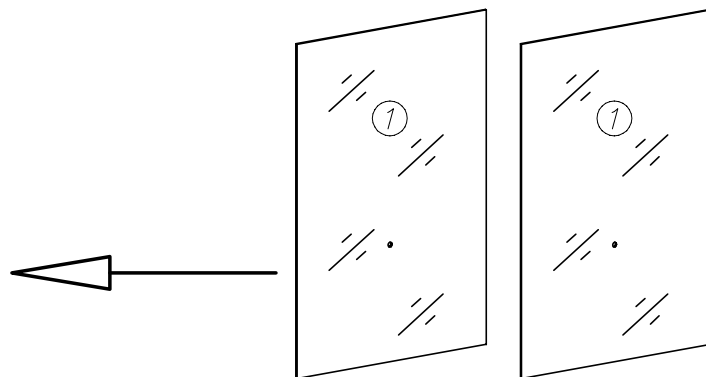
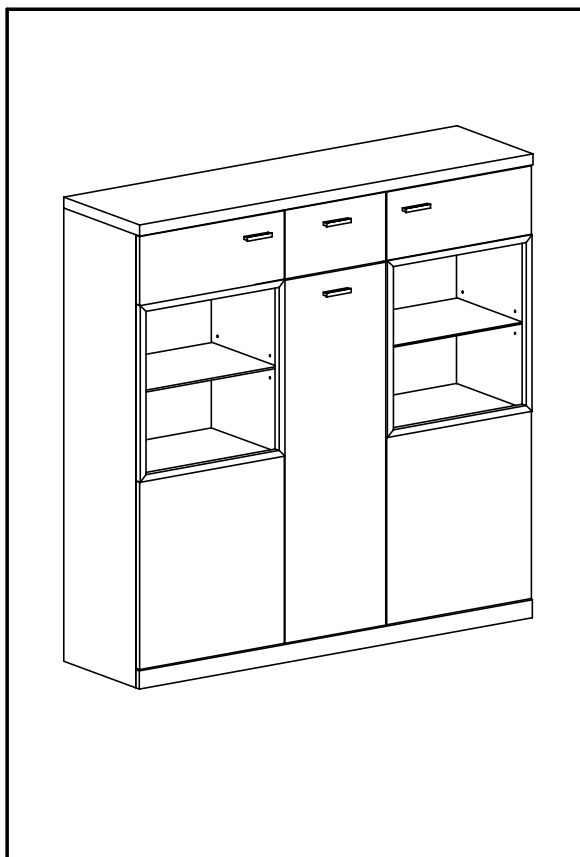

Colli 1/1 (1) x2

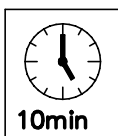
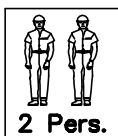
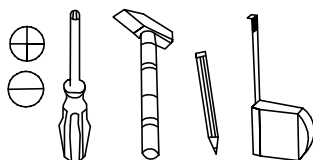
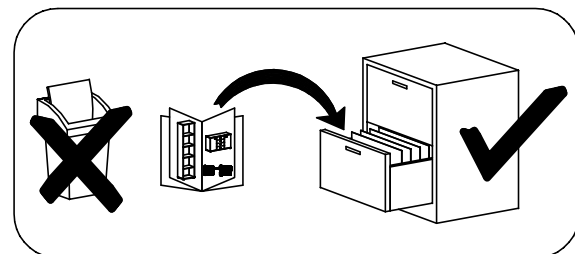

festziehen / tighten / Затянуть /
 serrer / stringere / utåhnout / vastrækken /
 zategniti / strångere / związac / zaciągac /
 szorosan meghúzni / pevne dotiahnut
 trdno pritegniti / затянуть / dra et



eindrücken / press in / enfoncer / wciąć
 ribatters / zaitač / Вжопаре / indrukken
 benyomni / stlačit / vtiisiti / tryck in
 introducere prin apăşare / адэміць



ausmessen / measure / mäsurer /
 misurare / opmeten / izmeriti / miera /
 kimēmi / izmeriti / mäsurare / юмерить
 změřit / Измерете / mät upp / zmierzyc



drücken / press / presser / stisknout /
 Hanovete / vtiisiti / nacinač / drukken /
 pritiisuti / nacinač / pritiisiti / нажатъ /
 (meg)nyomni / apăşare / tryck fast / nacinač



einschlagen / hammer in / beverni / sla in
 fropper au marteau / infossare / Zabit' /
 zarazit / Hašvete / zabiti / wbić
 introducere prin bōtaie / шавить / zaitlout



Drehen - wenden / przekręcić - odwrócić /
 Keren - amdraaien / Girare - Ruotare /
 Okrenuti - ubmuti / Retourner - renverser /
 Turn over - turn around / Otocite - obratite /
 Завърете - обвърете / Obmite list /
 Intoarceti - rotiti / Vrid runt - vänd /
 прокрутить - павярить / otočit - obrátit
 elforgatni - megfordítani

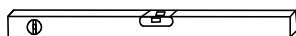

1

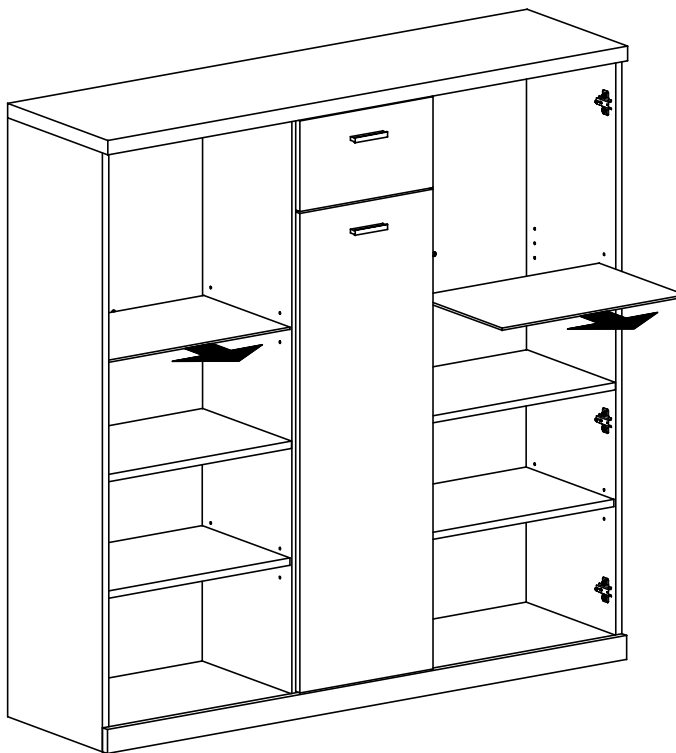

2

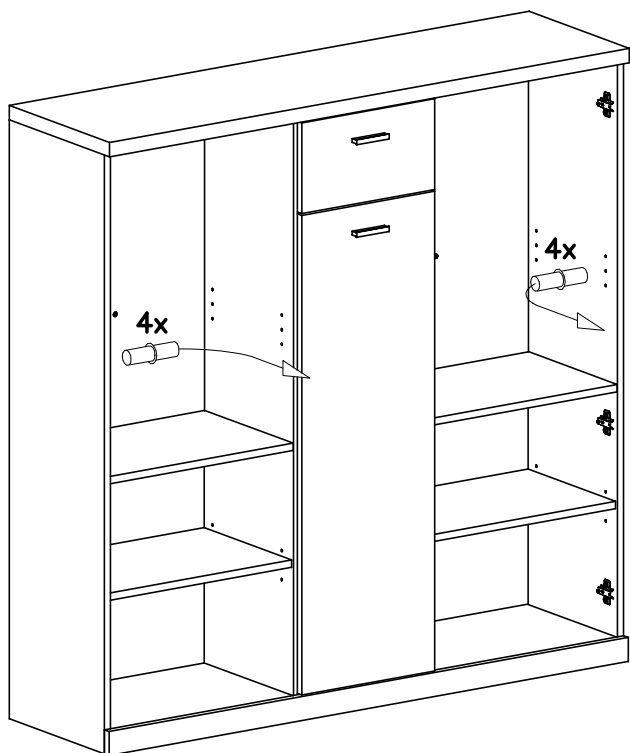

3

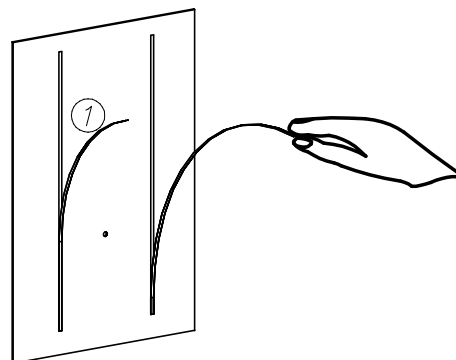
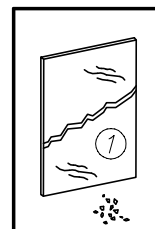
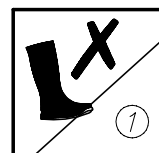

2x

4

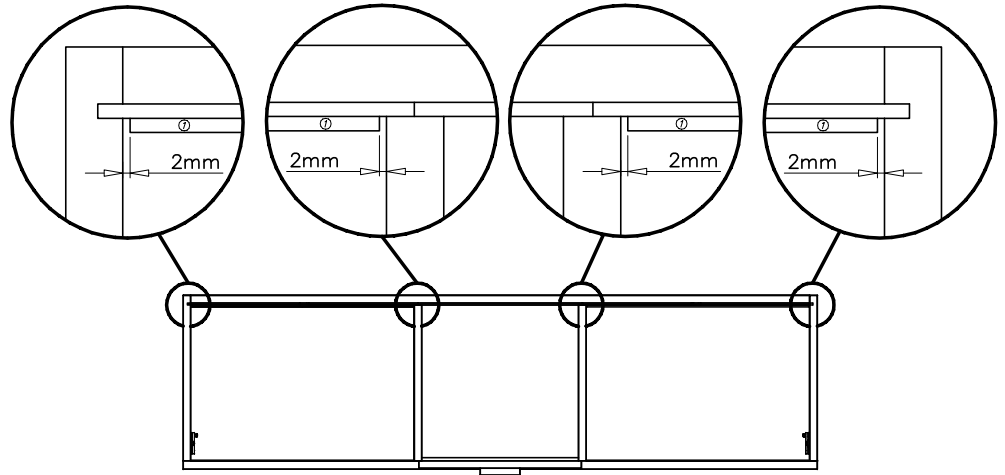
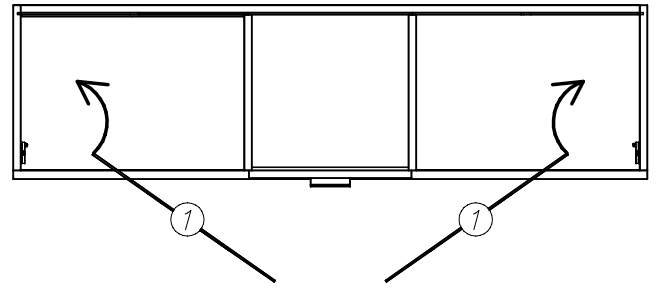
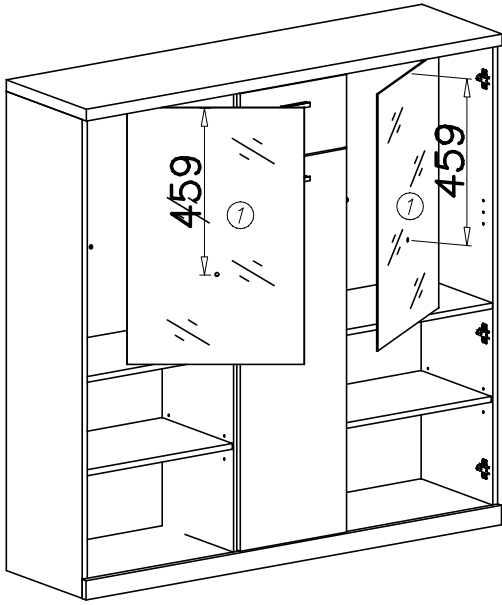

5

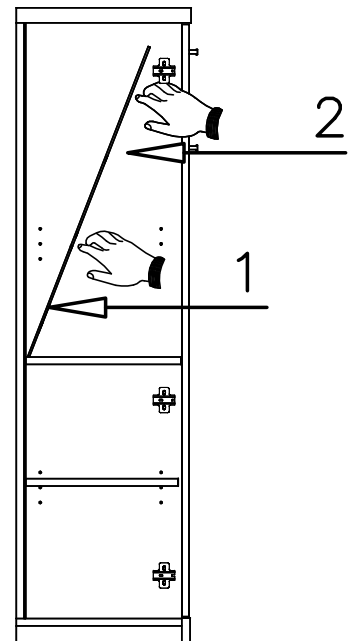
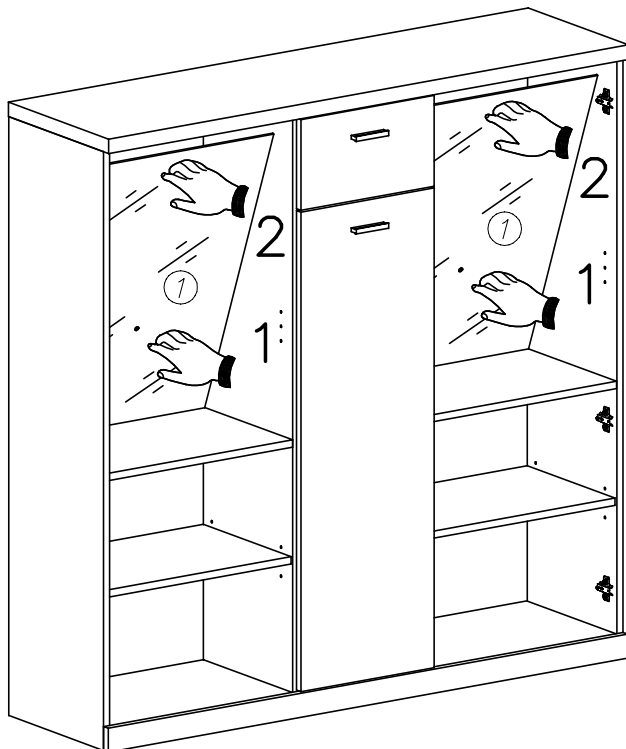

6



1

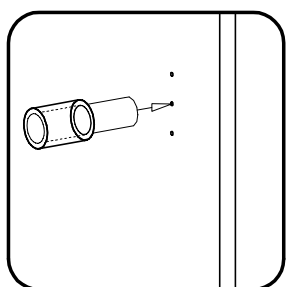

2

