

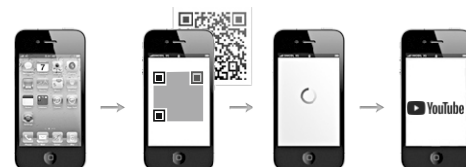

- | | | |
|---|--|--|
| (D) Videounterstützte Montageanleitung | (GB) Video-assisted assembly instructions | (FR) Instructions de montage assistées par vidéo |
| (TR) Video destekli kurulum talimatları | (IT) Istruzioni di montaggio video-assistite | (NL) Video-ondersteunde montage-instructies |
| (RU) инструкция по монтажу с помощью видеосигнала | (CZ) Instalační pokyny podporované videem | (HU) Video-támogatott telepítési utasítások |
| (RO) Instrucțiuni de instalare acceptate video | (PL) Instrukcje montażu wspomagane sygnałem wizyjnym | (SK) Inštaláčne pokyny podporované videom |

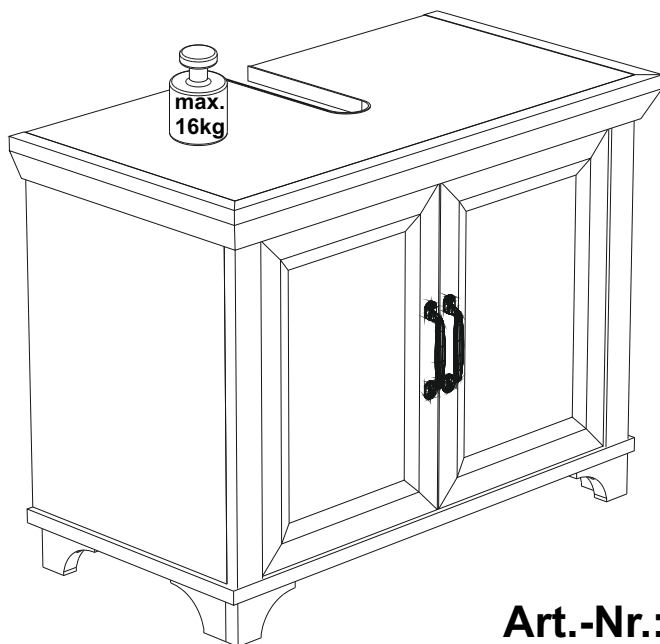

Art.-Nr.: **0101_WBU_2**

REPC-Nr.:

Waschbeckenunterschrank



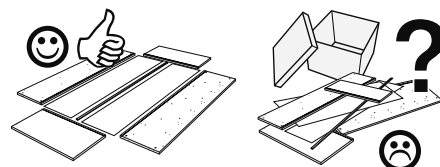
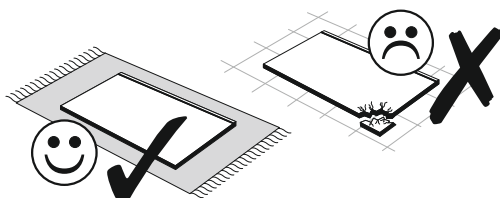
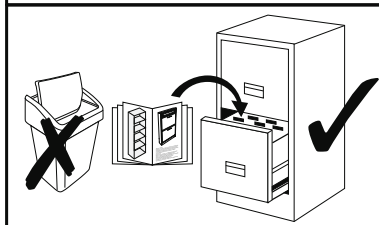
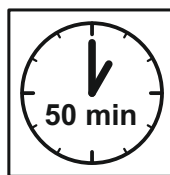
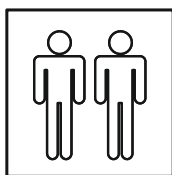
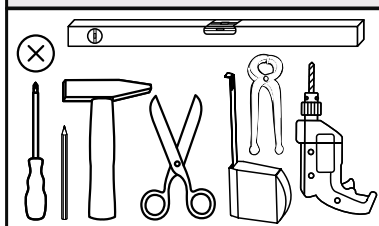





Service • Assistenza • Dienstverlening • Serwis
Servis • Szerviz • Сервисная служба

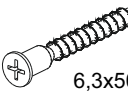

SCAN ME

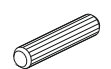
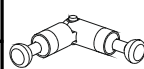
Das Ersatzteil-Anforderungsformular finden Sie auf
The replacement parts requisition form you find on
<https://www.maeusbacher.de/ersatzteile/>

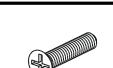
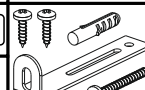

BT1-00289 Colli 1/1

B01-10 4x  6,3x50	B02-10 19x  ø15x12mm	B02-20 15x  6,3x30	B01-37 12x  4,5x25
B01-90 12x  3,5x20	B02-90 2x  6x30	B02-27 2x  3x16	B01-30 6x  3x16
B01-80 8x  3,5x13	B01-206 4x  6,3x22	B01-327 4x  M4x19	B08-80 1x 



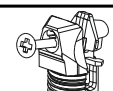
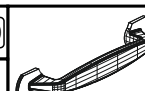

SCAN ME

BT1-00291 Colli 1/1

B05-130 1x  Leim	B05-185 4x 	B05-192 2x 	B06-500 2x 
--	--	--	--

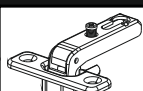
BT1-00290 Colli 1/1

B03-44 4x 	B03-44 4x 
---	---

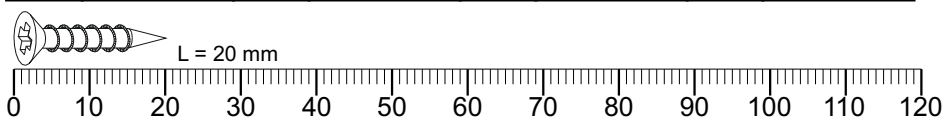

Colli 1/1

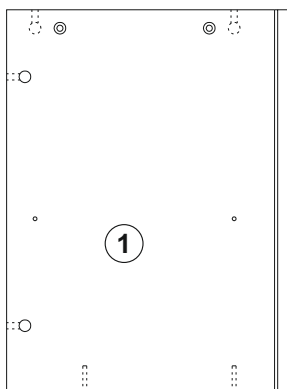
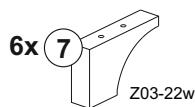

493x 362
FTx-00630

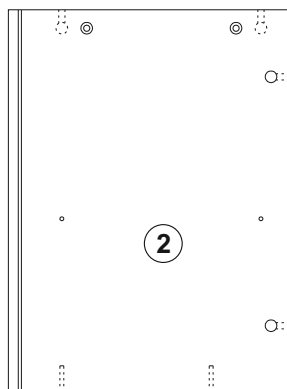

493x 362
FTx-00631

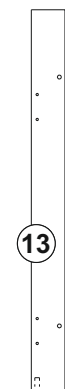

493 x 44
Z99-00617

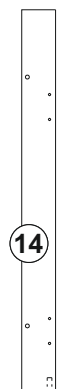

493 x 44
Z99-00618

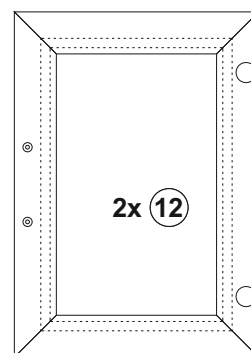

444 x 314
Z99-00614

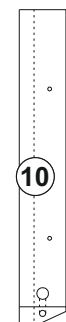

407x 60
Z99-00609

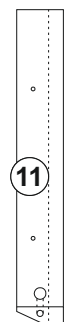

407 x 60
Z99-00610

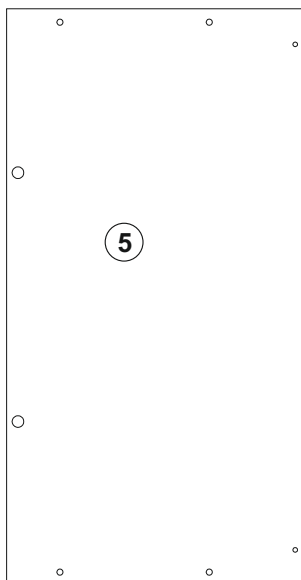

742 x 384
FTx-000632

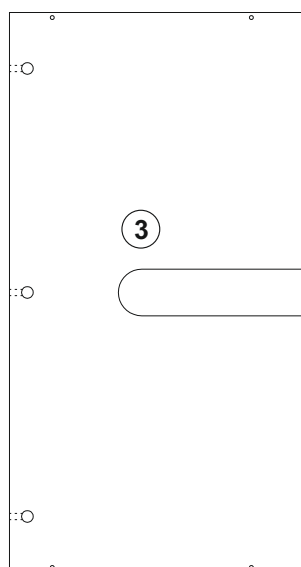

722 x 381
FTx-000634

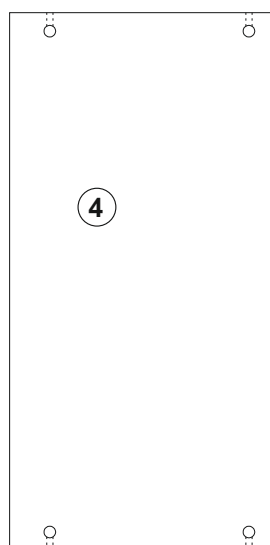

692 x 345
FTx-000633

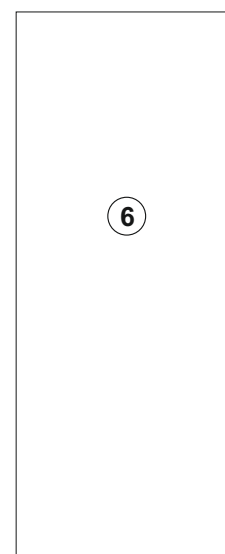

704 x 280
HTR-00459

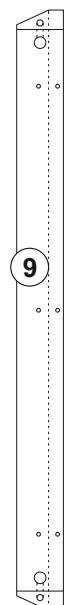

772 x 60
Z99-00603

1		B02-10		B02-20	B05-130		B02-27	
		4x	ø15x12mm	3x	1x		2x	

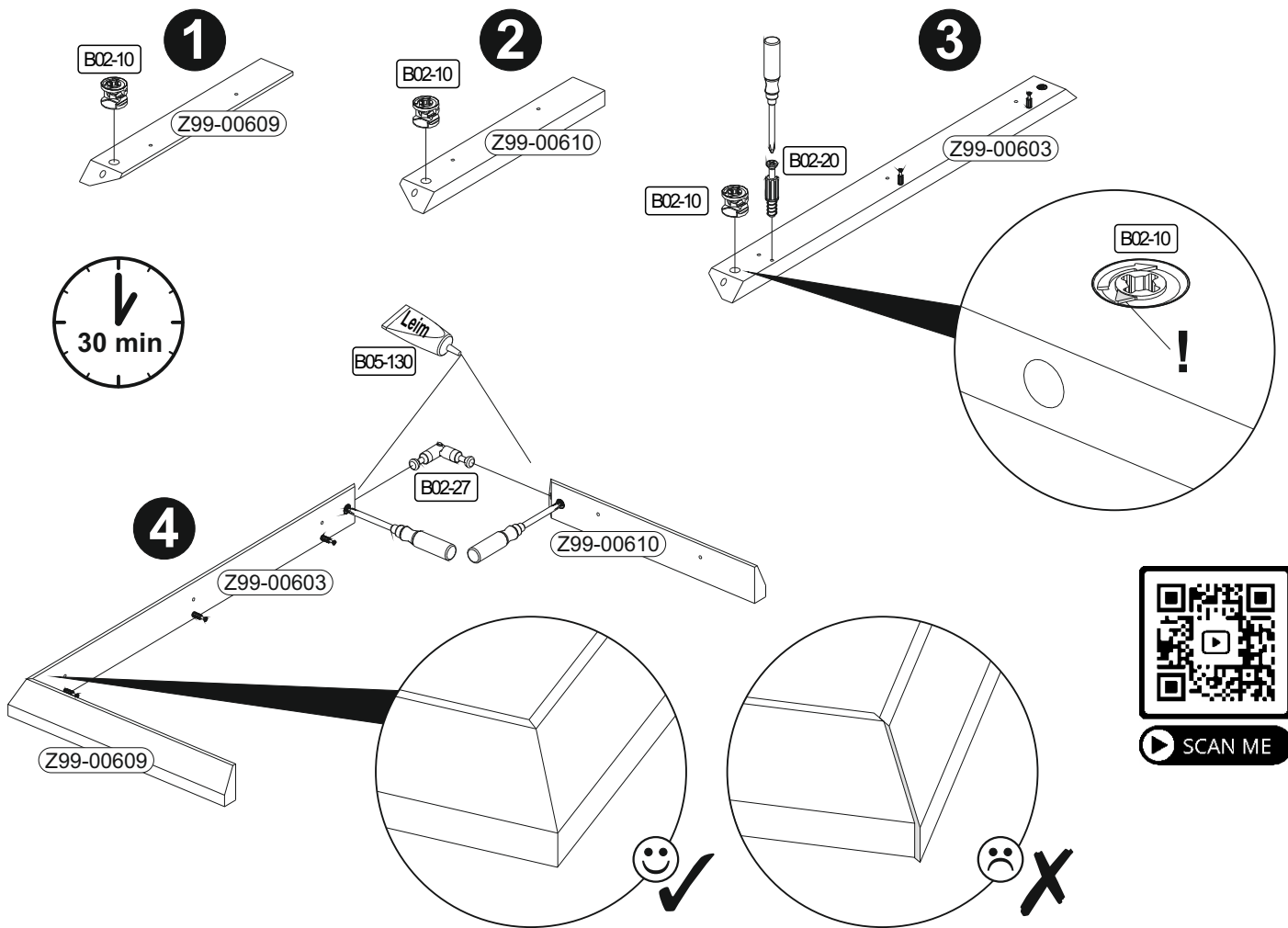

2		B02-10		B02-20	
		3x	ø15x12mm	4x	

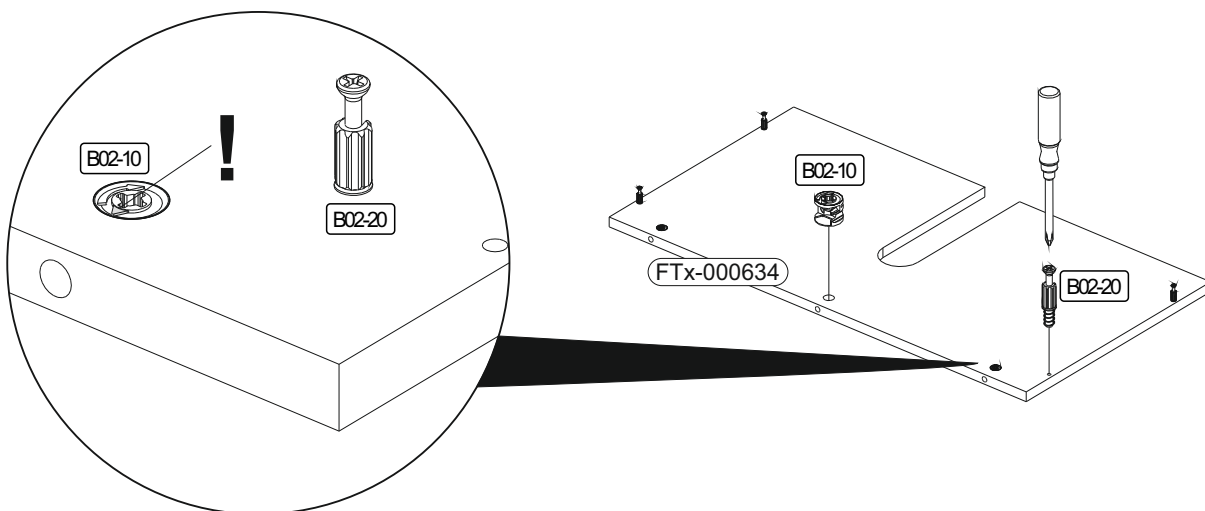

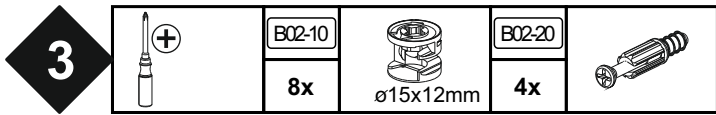

1

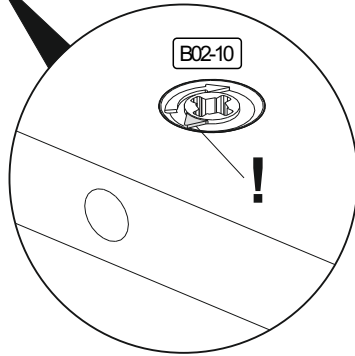
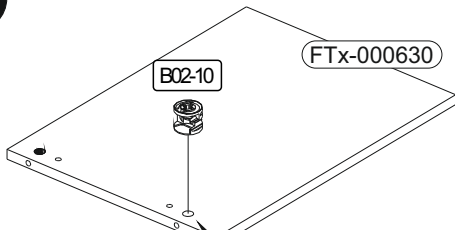

2

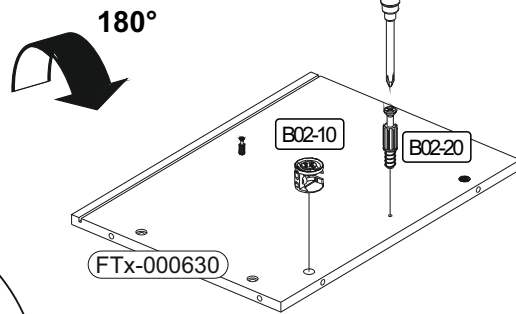

3

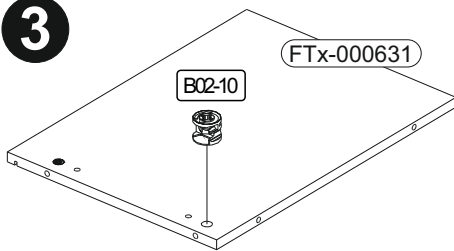

4

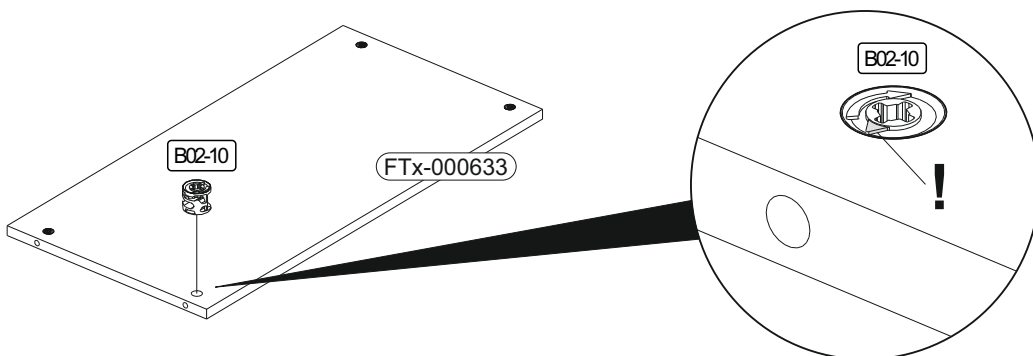
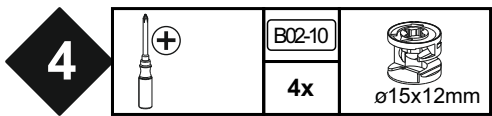
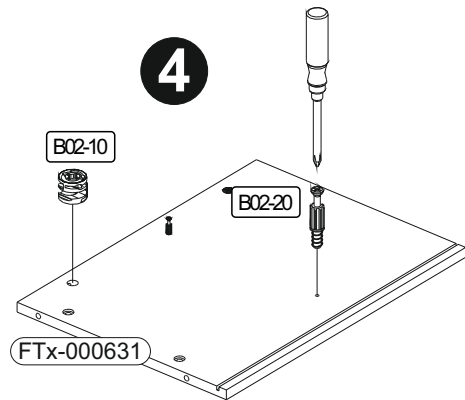

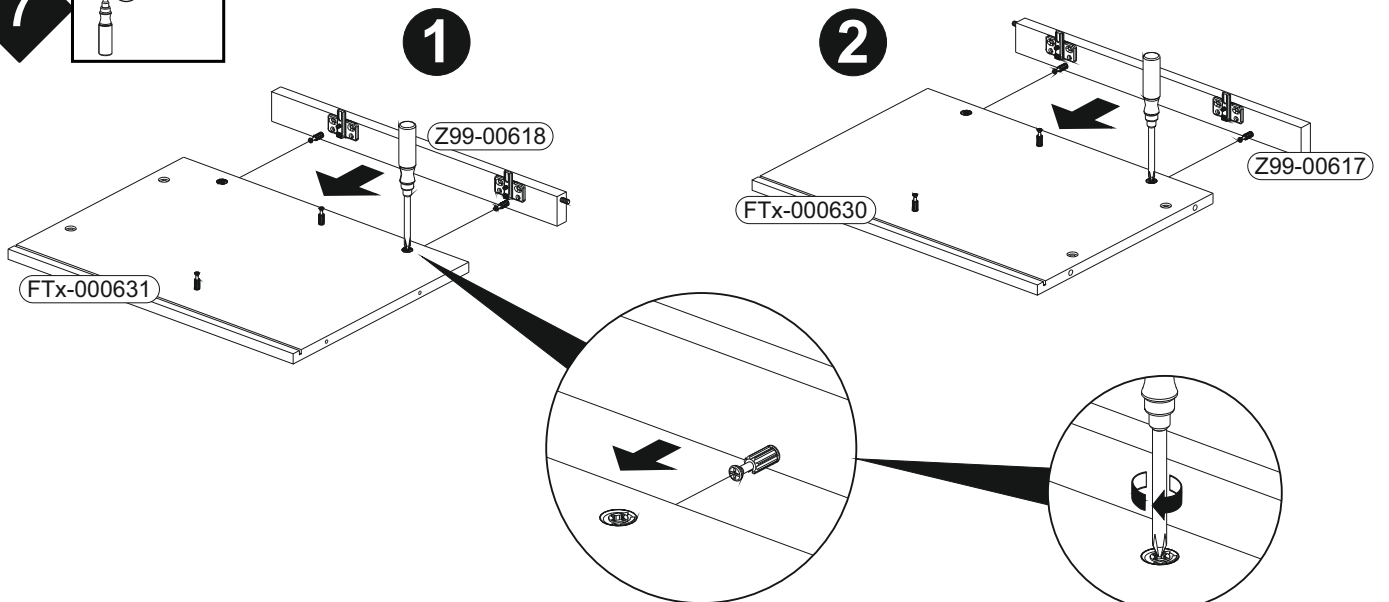
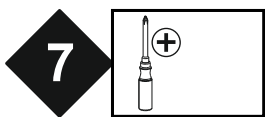
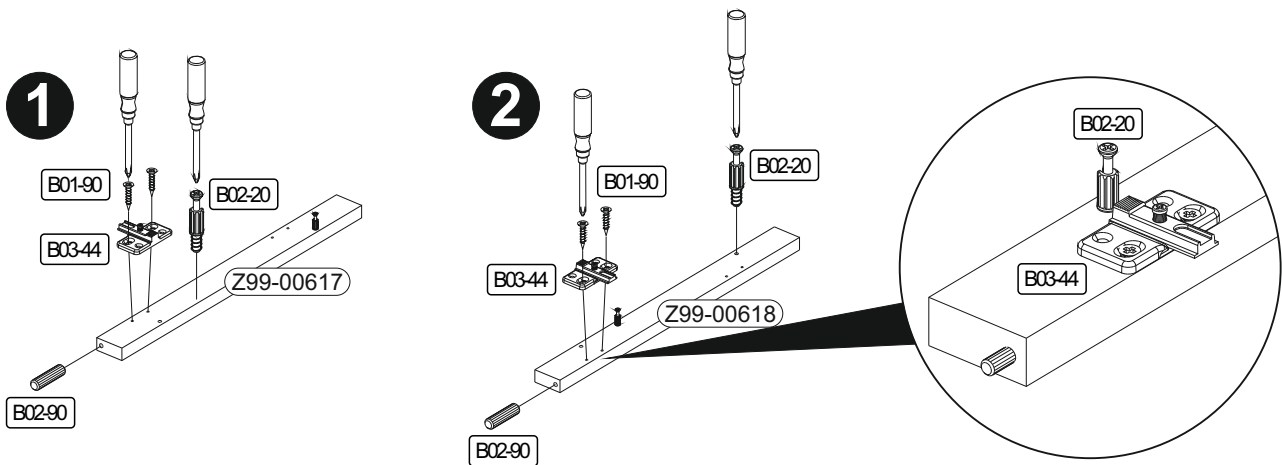
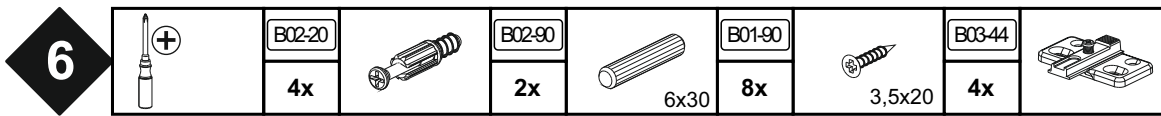
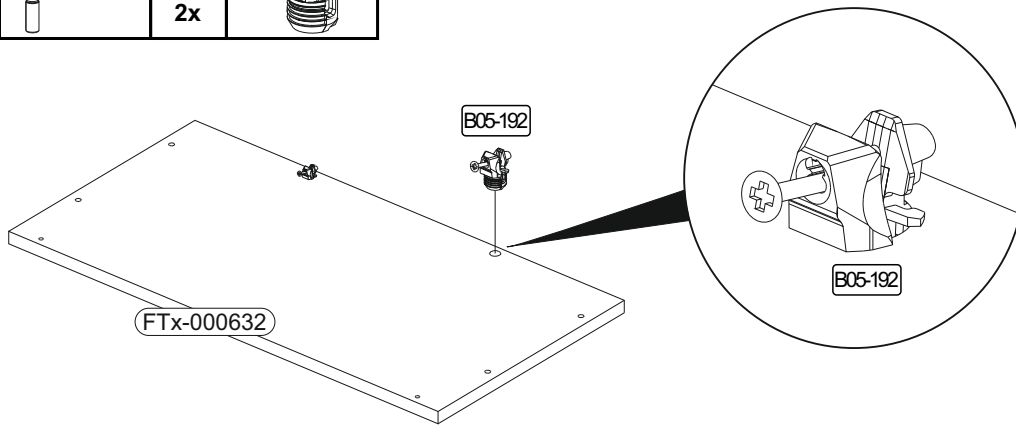
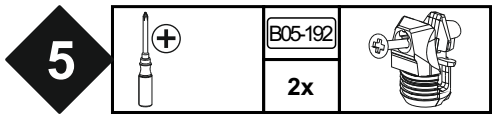

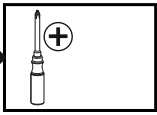
8 

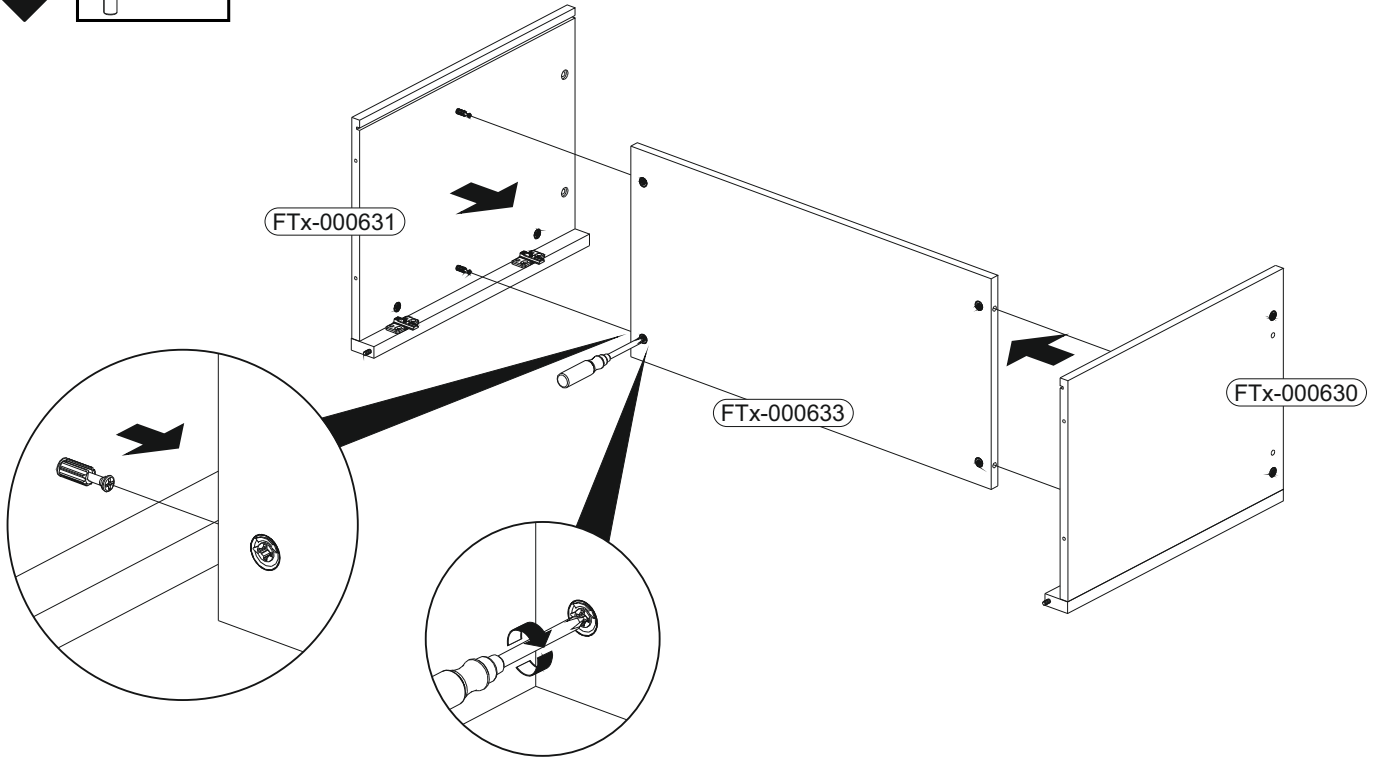

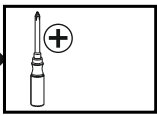
9 

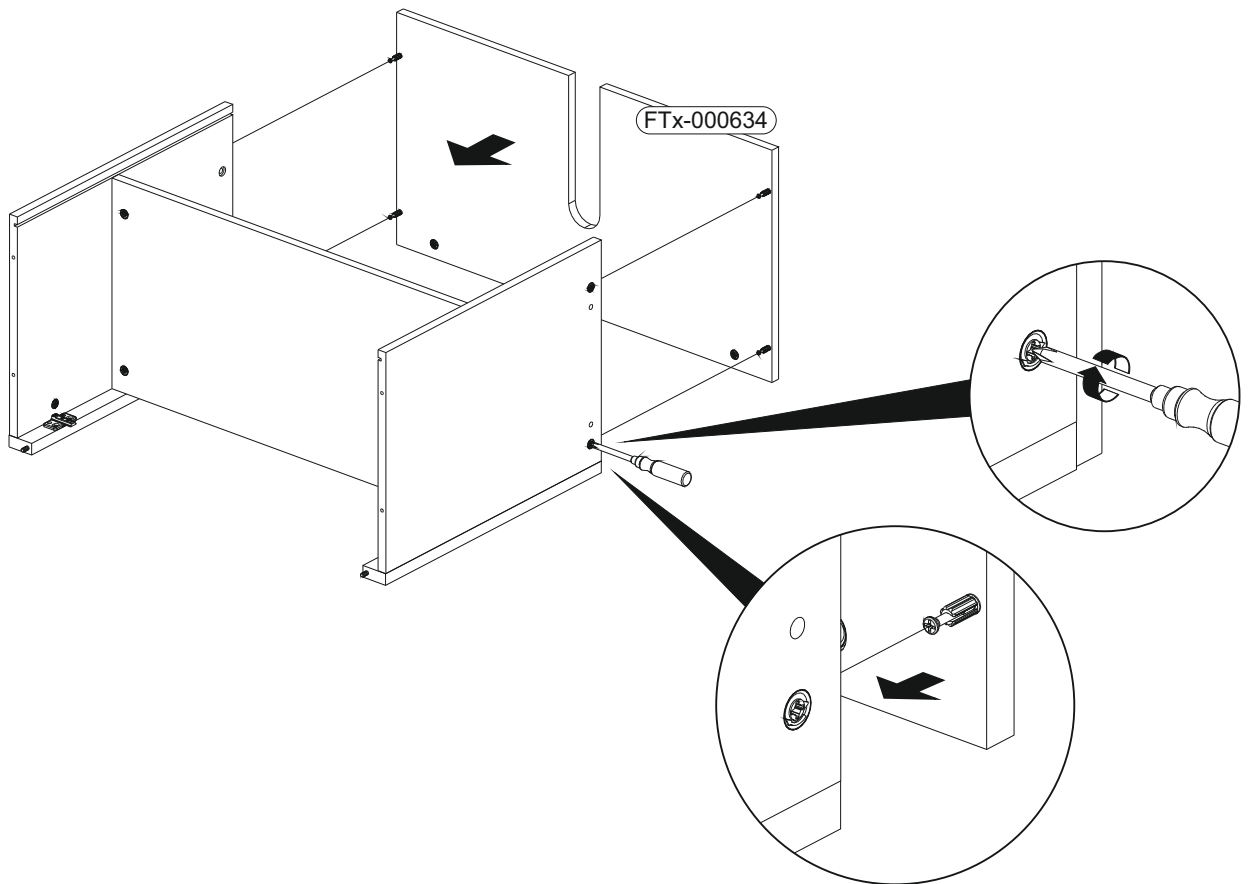

10

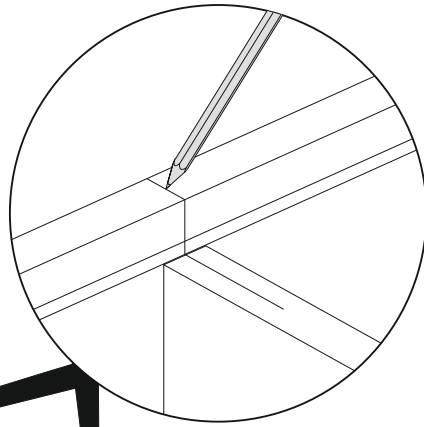
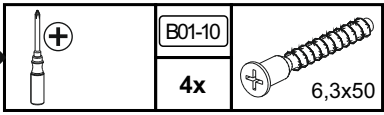

1

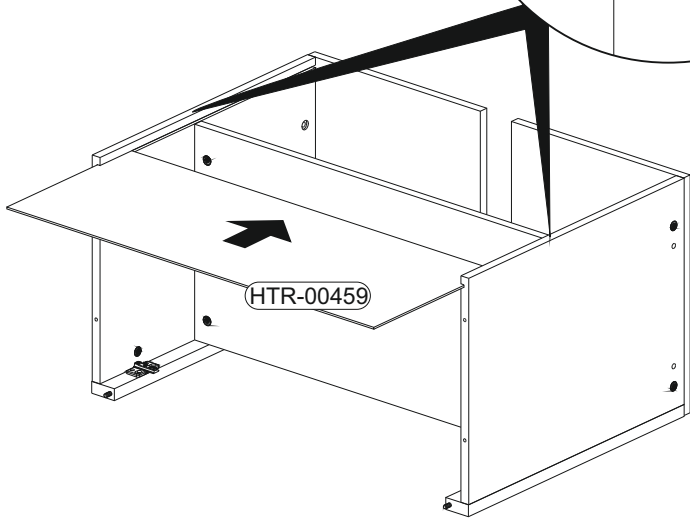

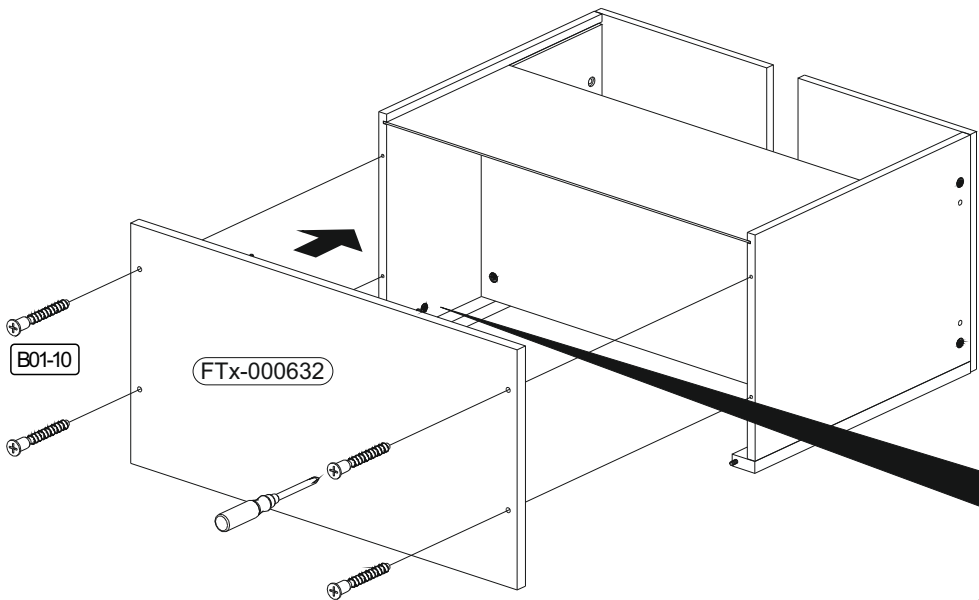

2



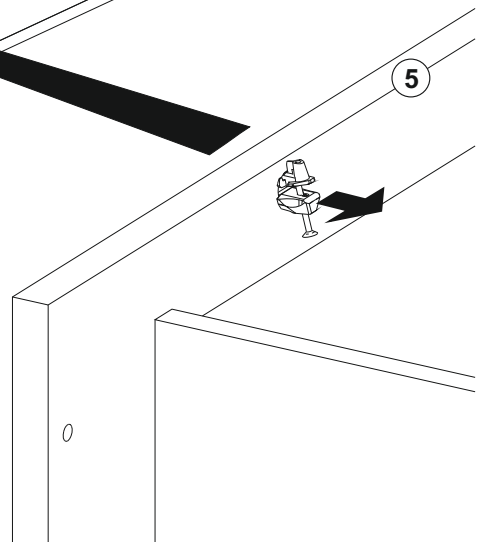

3



11

	B05-185		B01-37		B01-90		B01-30	
	4x		12x	4,5x25	4x	3,5x20	6x	3x16

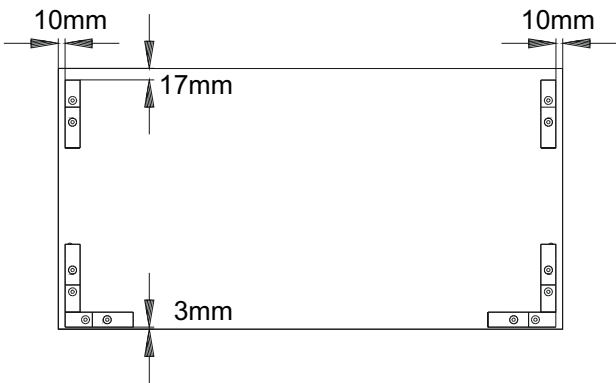
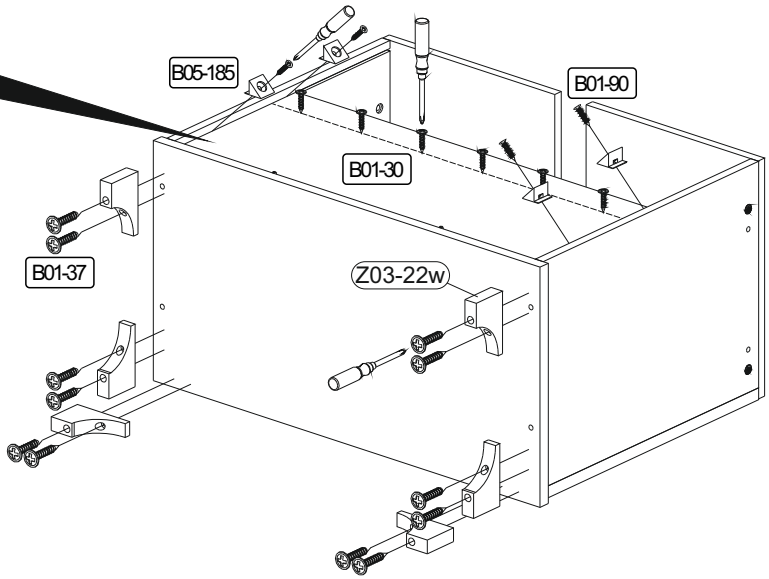
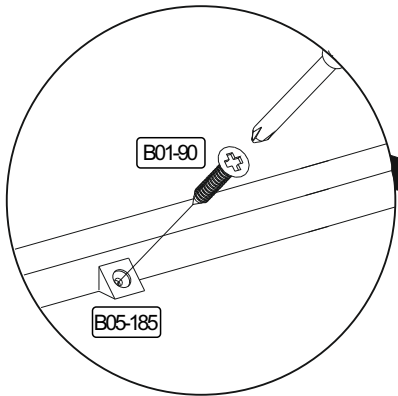
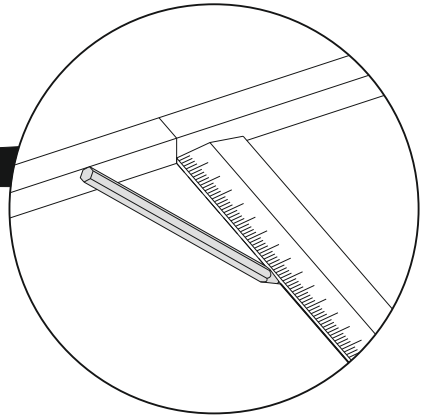
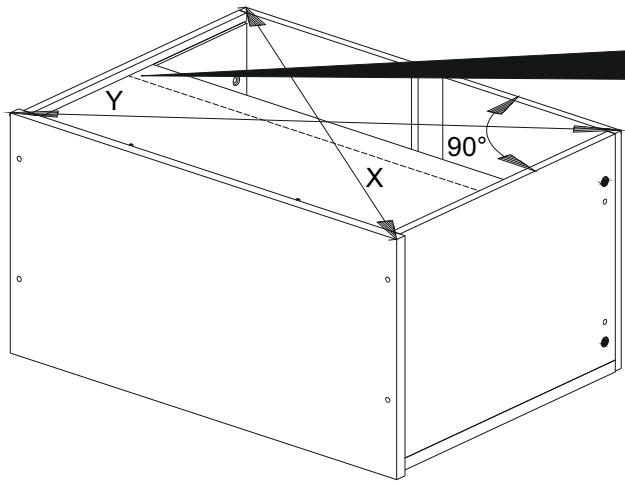
X=Y

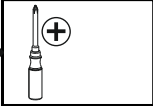

12 

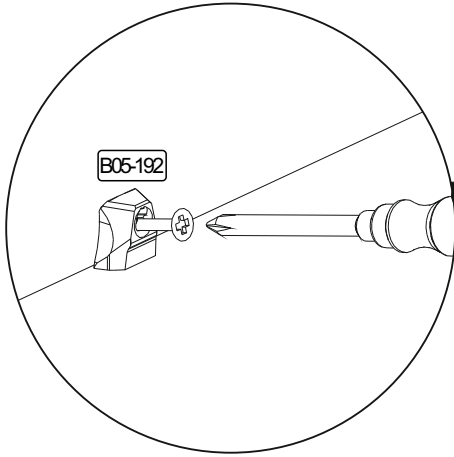
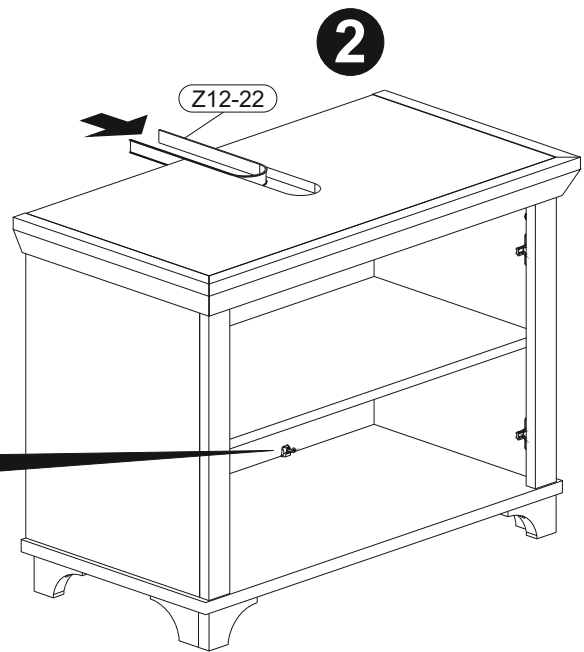
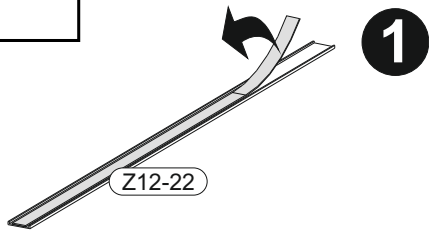

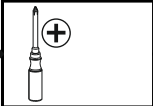
13 

B01-206
4x

 6,3x22

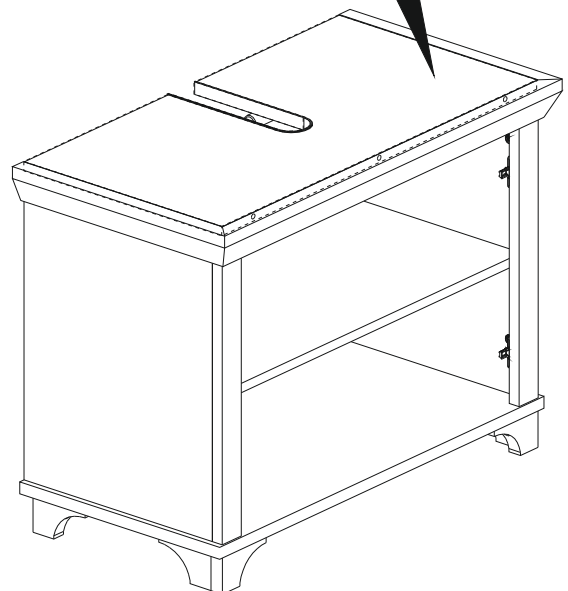
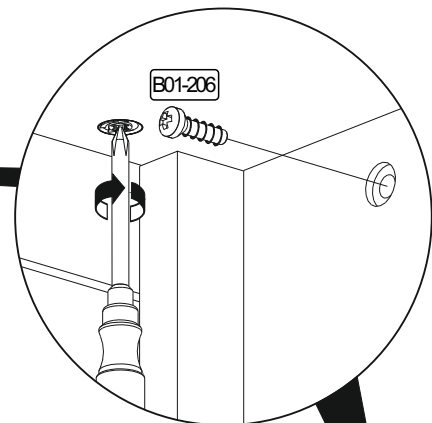
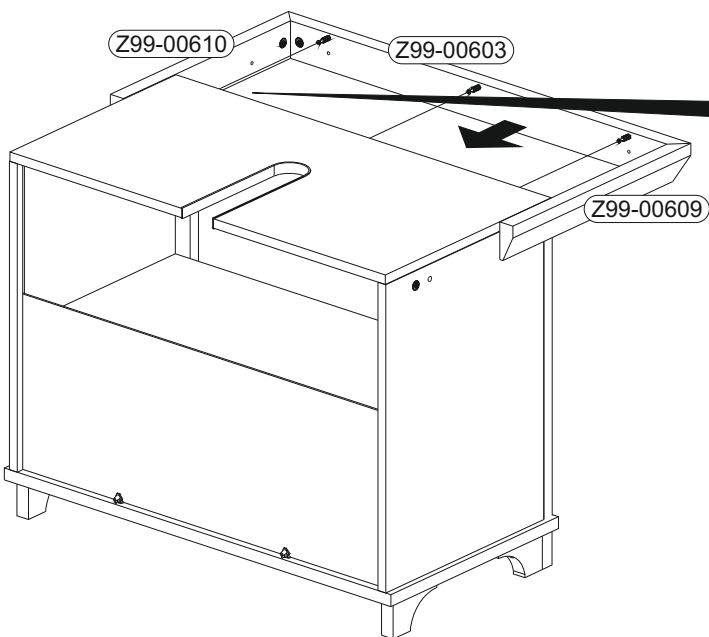

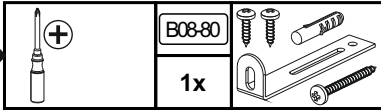

14

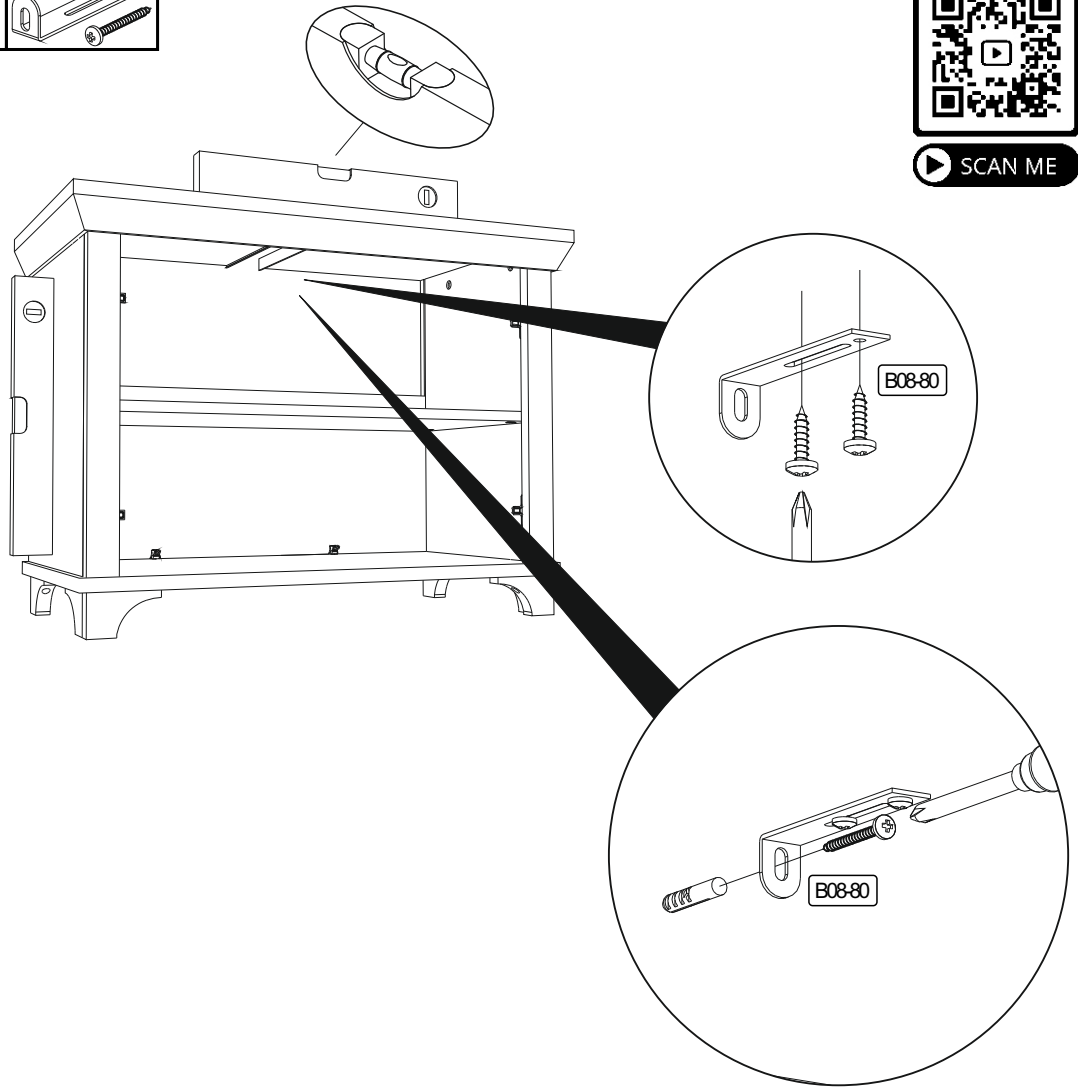
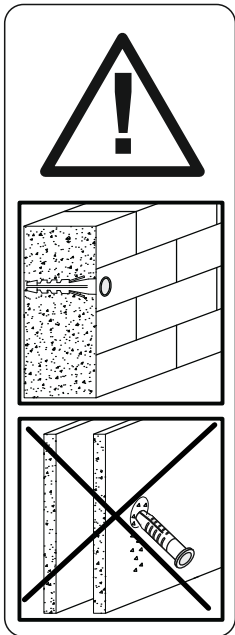

SCAN ME



 Achtung • Attention • Attenzione • Opgelet • Uwaga • Pozor • Figyelem • Atenție • Dikkat • Внимание 	
(D)	Wandbefestigung dient als Kippschutz - unbedingt anbringen! Bei einigen Wandtypen kann ein Spezialdübel erforderlich sein!
(GB)	The wall fastening serves to prevent tipping - be absolutely sure to mount it! For certain wall types, a special wall plug may be necessary!
(FR)	La fixation murale sert de protection contre le basculement – à installer impérativement ! Pour certains types de murs il faut des chevilles spéciales !
(TR)	Duvardaki sabitleme, devrilmeye karşı bir emniyet tedbiridir ve mutlaka monte edilmelidir! Bazı duvar tiplerinde bunun için özel bir dübel gerekli olabilir!
(IT)	Il fissaggio alla parete serve da protezione anti-ribaltamento – attaccarla assolutamente! Per alcune strutture di parete può essere necessario un tassello speciale!
(NL)	Bevestiging aan de muur dient als kantelbescherming – zeker en vast bevestigen! Bij enkele muurtypes is een speciale plug misschien vereist!
(RU)	Обязательно установите крепление на стене во избежание опрокидывания! Для некоторых типов стен может потребоваться специальный дюбель!
(CZ)	Montáž na stěnu slouží jako ochrana proti převrnutí – bezpodmínečně umístěte! U některých typů stěn může být zapotřebí speciální hmoždinka!
(HU)	A terméket a falhoz kel rögzíténi, különbén az felborulhat! Egyes faltípusoknál speciális tiplit kell használni!
(RO)	Sistemul de fixare la perete servește ca protecție la răsturnare - de montat obligatoriu! Pentru unele tipuri de pereti este posibil să fie necesar un diblu special!
(PL)	Mocowanie do ściany jest jednocześnie zabezpieczeniem przed przewróceniem – koniecznie zamontować! Do niektórych rodzajów ścian koniecznie zastosować specjalne kołki mocujące.
(SK)	Upevnenie na stenu slúži ako ochrana proti prevráteniu – bezpodmienečne použite! Pre niektoré druhy stien môže byť potrebná špeciálna hmoždinka!

15

	B03-44		B01-80		B06-500		B01-327	
	4x		8x	3,5x13	2x		4x	M4x19

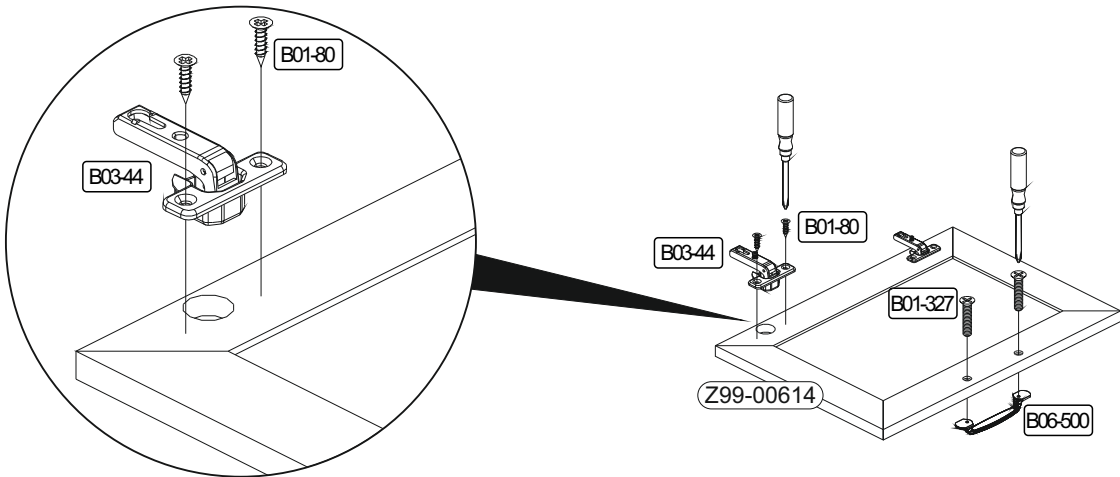

16

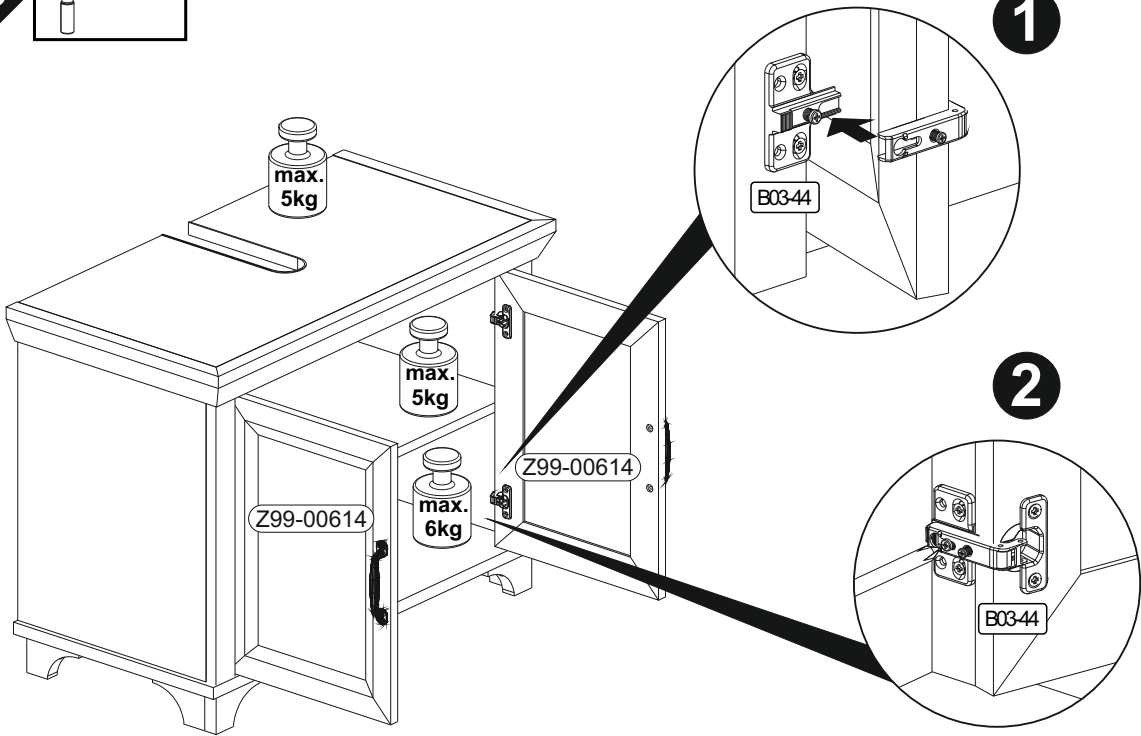
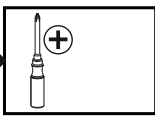

▶ SCAN ME

Türen einstellen (Scharniere justieren)

Adjusting the doors (adjusting the hinges)

Régler les portes (ajuster les charnières)

Sistemare le porte (regolare le cerniere)

Deuren instellen (scharnieren afstellen)

Nastawić drzwi (wyregulować zawiasy)

Vyrovnejte dvířka (seřid'te závěsy)

Nastavenie dverí (nastavenie závesov)

Állítsa be az ajtókat (állítsa be a zsanérokot)

Reglare uși (ajustare balamale)

Kapıların ayarlanması (mentşelerin seviye ayarı)

Регулировка дверей (регулировка шарнира)

