

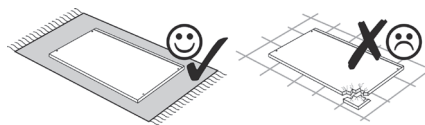

87105.330

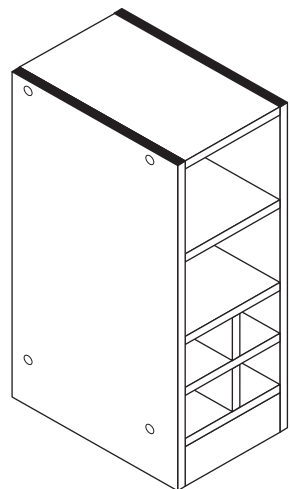

1 8 x 2827	2 8 x 2821	3 5/5 x 16 4 x 2821	4 4 x 9 2 x	5 5 x 30 1 x	50 x 2862
6 8 x 30 28 x 2861	7 4 x 27 4 x 2829	8 1 x 2863			

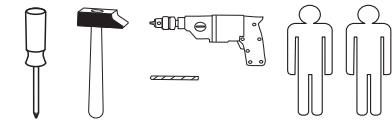
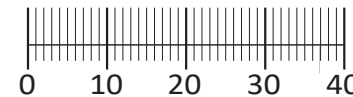

Das beigegefügte Wandbefestigungsmaterial (Dübel und Schrauben) eignet sich nur für festes Mauerwerk (z.B.: Beton- oder Ziegelwände). Für andere Wandaufbauten sind eventuell Spezialdübel und andere Schrauben notwendig. Ziehen Sie gegebenenfalls eine Fachkraft zu Rate.

De begeleidende wandmontage hardware (pluggen en schroeven) is alleen geschikt voor massief metselwerk (bijvoorbeeld beton of bakstenen muren). Voor andere muur structuren zijn eventueel bijzondere ankerbouten en andere noodzakelijke. Draai indien nodig, een deskundige.

Приложенный материал для крепления к стене (дюбели и винты) пригоден только для жестких кладок (например, бетонные или кирпичные стены). Для других настенных конструкций необходимы смотря по обстоятельствам специальные дюбели и другие винты. При необходимости проконсультируйтесь у специалиста.

Le mur d'accompagnement matériel de montage (chevilles et les vis) ne convient que pour la maçonnerie solide (par exemple en béton ou des murs de briques). Pour les structures de mur d'autres sont peut-être spéciale boulons d'ancrage et d'autres nécessaires. Serrer le cas échéant, un expert.

Załączony materiał do mocowania do ściany (kolki rozprężne i wkręty) nadaje się tylko do ścian murowanych (np. z betonu lub cegieł). Do ścian wykonanych w innych technologiach konieczne być mogą specjalne kolki rozprężne i inne wkręty. W razie potrzeby skorzystaj z fachowej pomocy

Il muro di accompagnamento hardware di montaggio (tasselli e viti) è'e adatto solo per muratura piena (ad esempio calcstruzzo o muratura). Per le altre strutture murarie sono forse speciali bulloni di ancoraggio e necessari di altri. Serrare se necessario, un esperto.

The accompanying wall mounting hardware (anchors and screws) is suitable only for solid masonry (eg concrete or brick walls). For other wall structures are possibly special anchor bolts and other necessary. Tighten if necessary, an expert.

Ekteki duvara sabit montaj malzemeleri (dübel ve vidalar), sadece sağlam duvarlar için (örnek: beton veya tuğla) elverişlidir. Başka duvarlar için özel dübeller ve farklı vidalar gerekebilir. Gerektiğinde bir uzmana danışınız.

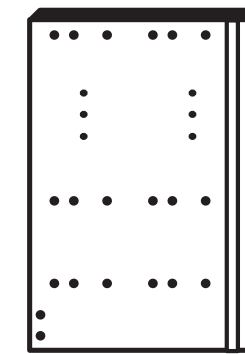

10 1 x

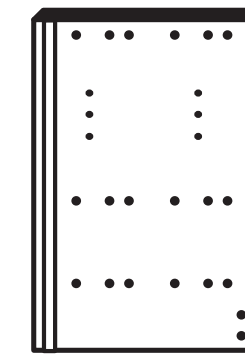

11 1 x



12 3 x



13 1 x



14 1 x



15 2 x

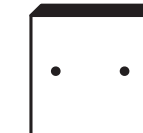

16 1 x



17 1 x

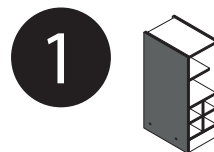

3	5/5 x 16 4 x 2821
---	-------------------------

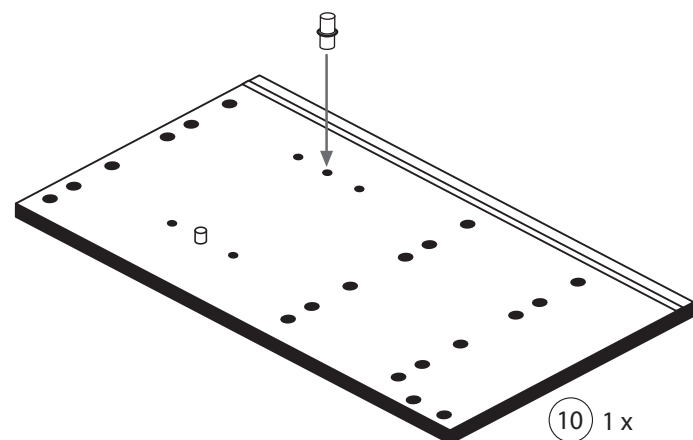

10 1 x

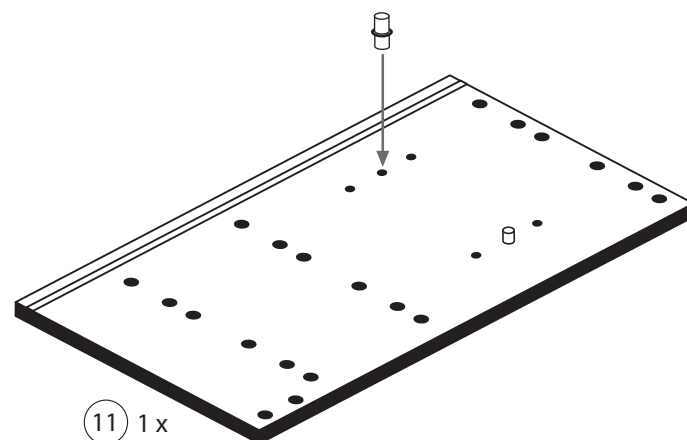

11 1 x

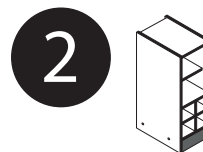

6	8 x 30 4 x 2861
8	1 x 2863

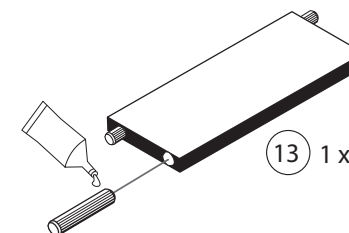

13 1 x

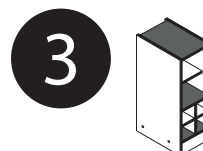

6	8 x 30 24 x 2861
8	1 x 2863

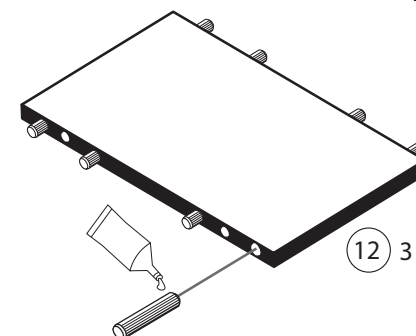

12 3 x

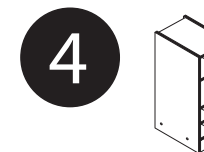

Bohren Sie 2 Löcher wie abgebildet in einen Boden 12

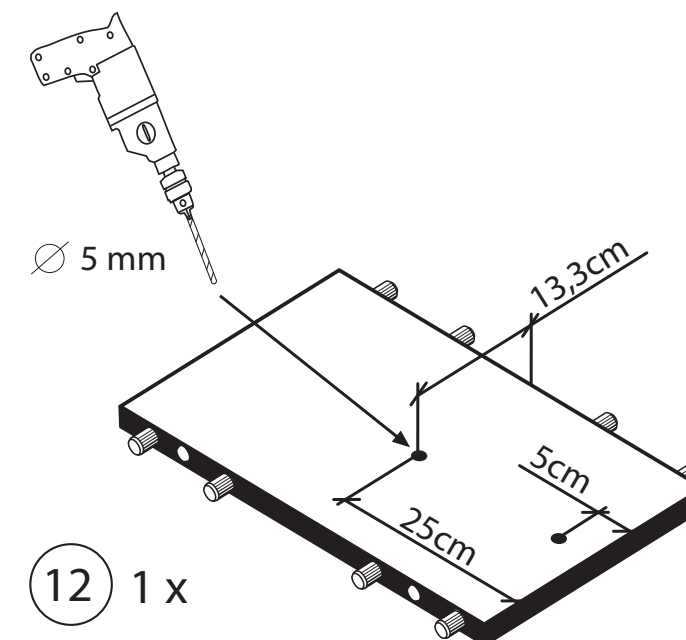

12 1 x

5

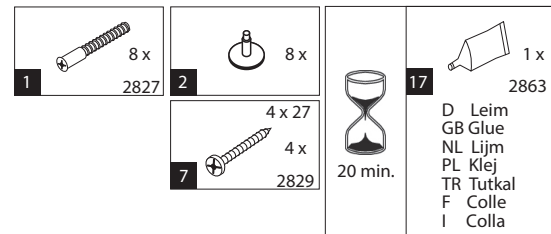

Wenn Sie den Schrank mit der Arbeitsplatte verbinden möchten bohren Sie 4 Löcher (5mm) in den Oberboden und befestigen den Schrank dann mit Hilfe der Schrauben (4x) an der Arbeitsplatte.

7

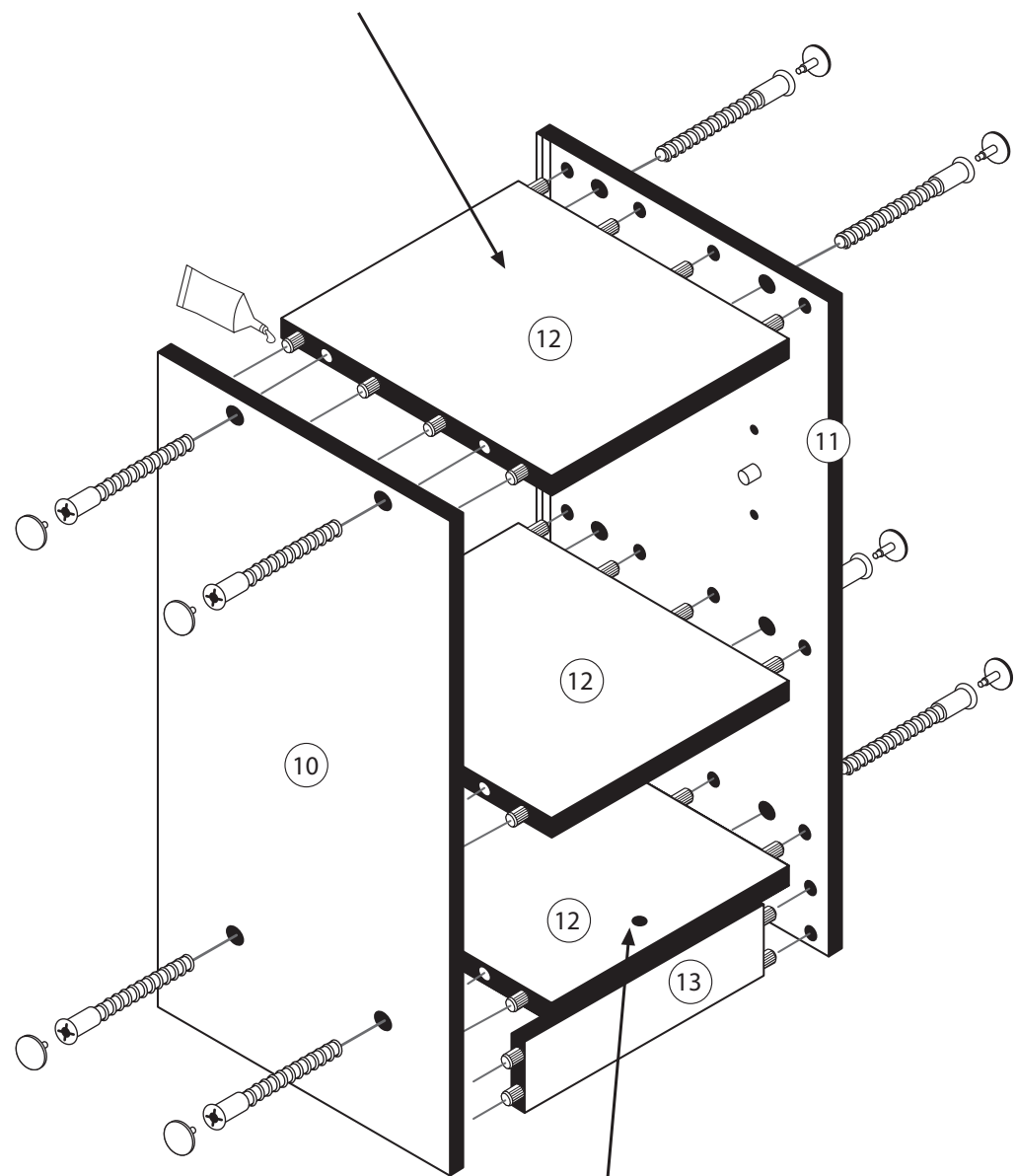

Wichtig!
Boden mit Bohrungen
nach unten!

6

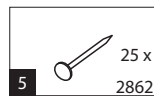
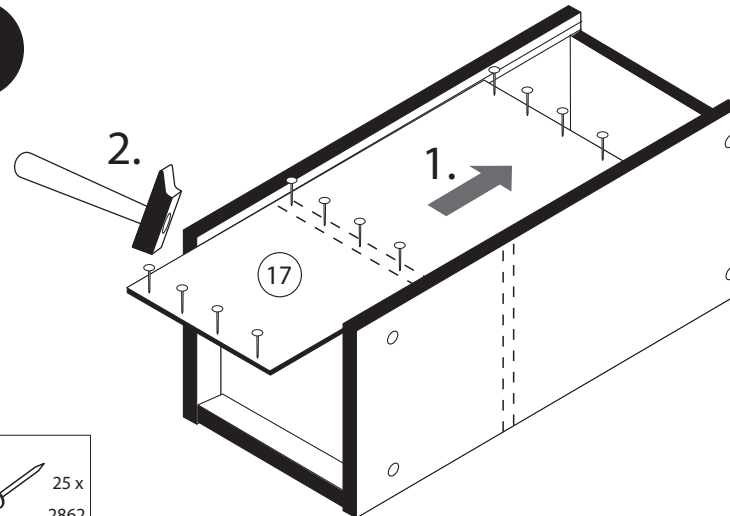

7

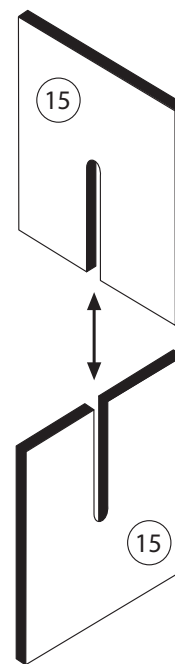

8

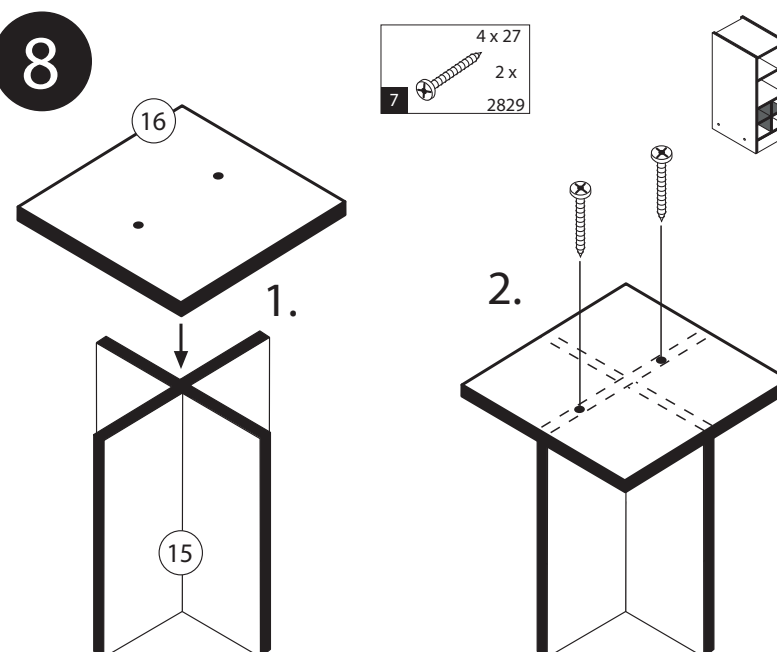

9

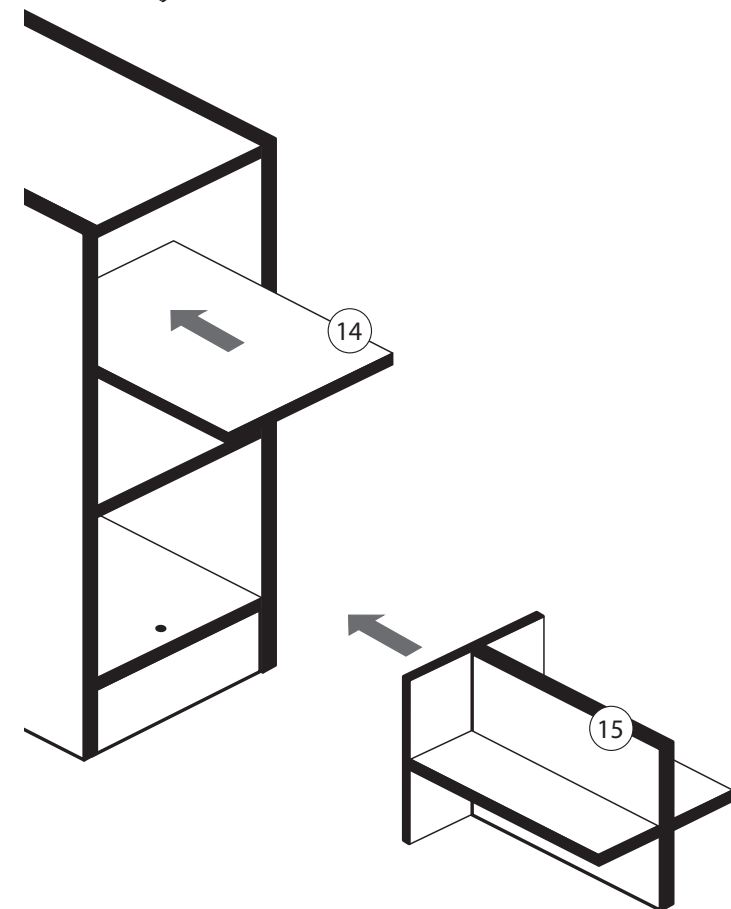

10

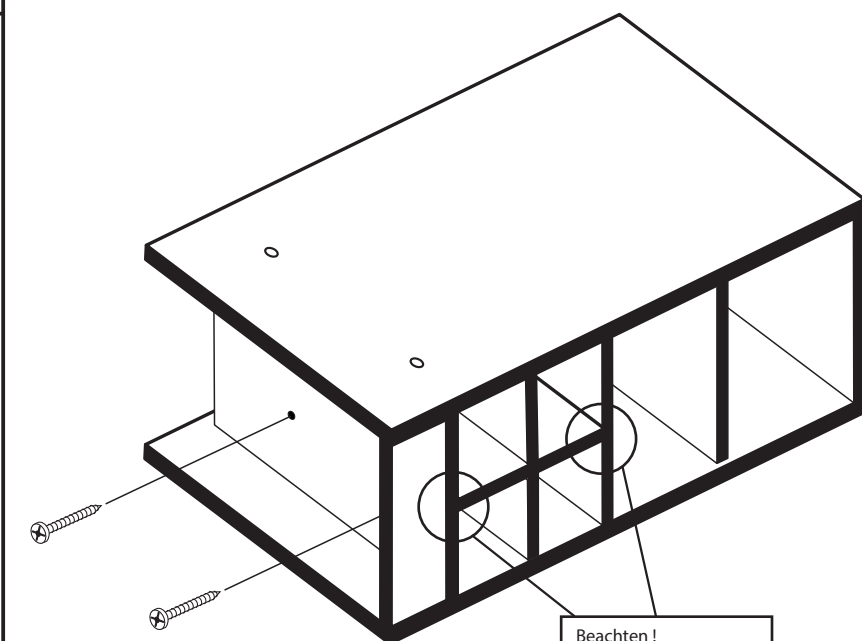
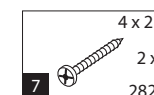

Beachten!
Vorderkante bündig!



87017.330

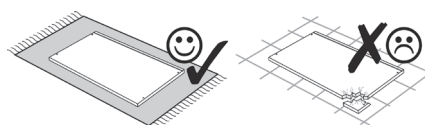
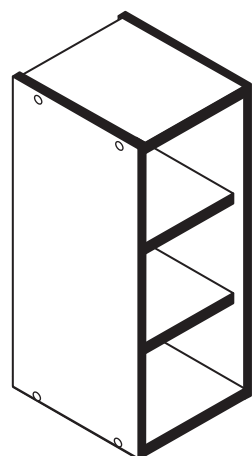
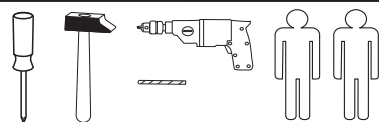

1 8 x 2843	2 8 x 2827	3 8 x 30 2861	4 5/5 x 16 8 x 2821
5 2 x 2843	6 4 x 30 4 x 2812	7 4 x 9 2 x 2862	8 5 x 30 1 x 2863
9 5,8 x 55 2 x 2840	10 8 x 30 2 x 2842	11 25 x 2862	

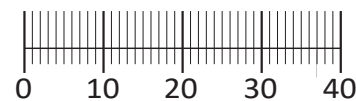

Das beigegefügte Wandbefestigungsmaterial (Dübel und Schrauben) eignet sich nur für festes Mauerwerk (z.B.: Beton- oder Ziegelwände). Für andere Wandaufbauten sind eventuell Spezialdübel und andere Schrauben notwendig. Ziehen Sie gegebenenfalls eine Fachkraft zu Rate.

De begeleidende wandmontage hardware (pluggen en schroeven) is alleen geschikt voor massief metselwerk (bijvoorbeeld beton of bakstenen muren). Voor andere muur structuren zijn eventueel bijzondere ankerbouten en andere noodzakelijke. Draai indien nodig, een deskundige.

Приложенный материал для крепления к стене (дюбели и винты) пригоден только для жестких кладок (например, бетонные или кирпичные стены). Для других настенных конструкций необходимы смотря по обстоятельствам специальные дюбели и другие винты. При необходимости проконсультируйтесь у специалиста.

Le mur d'accompagnement matériel de montage (chevilles et les vis) ne convient que pour la maçonnerie solide (par exemple en béton ou des murs de briques). Pour les structures de mur d'autres sont peut-être spéciale boulons d'ancrage et d'autres nécessaires. Serrer le cas échéant, un expert.

Załączony materiał do mocowania do ściany (kolki rozprężne i wkręty) nadaje się tylko do ścian murowanych (np. z betonu lub cegieł). Do ścian wykonanych w innych technologiach konieczne być mogą specjalne kolki rozprężne i inne wkręty. W razie potrzeby skorzystaj z fachowej pomocy

Il muro di accompagnamento hardware di montaggio (tasselli e viti) è adatto solo per muratura piena (ad esempio calcestruzzo o muratura). Per le altre strutture murarie sono forse speciali bulloni di ancoraggio e necessari di altri. Serrare se necessario, un esperto.

The accompanying wall mounting hardware (anchors and screws) is suitable only for solid masonry (eg concrete or brick walls). For other wall structures are possibly special anchor bolts and other necessary. Tighten if necessary, an expert.

Ekteki duvara sabit montaj malzemeleri (dübel ve vidalar), sadece sağlam duvarlar için (örnek: beton veya tuğla) elverişlidir. Başka duvarlar için özel dübeller ve farklı vidalar gerekebilir. Gerektiğinde bir uzmana danışınız.

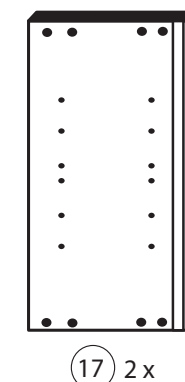
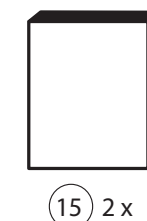

1



4 5/5 x 16 4 x 2821	5 2 x 2843	6 4 x 30 4 x 2812
------------------------------	------------------	----------------------------

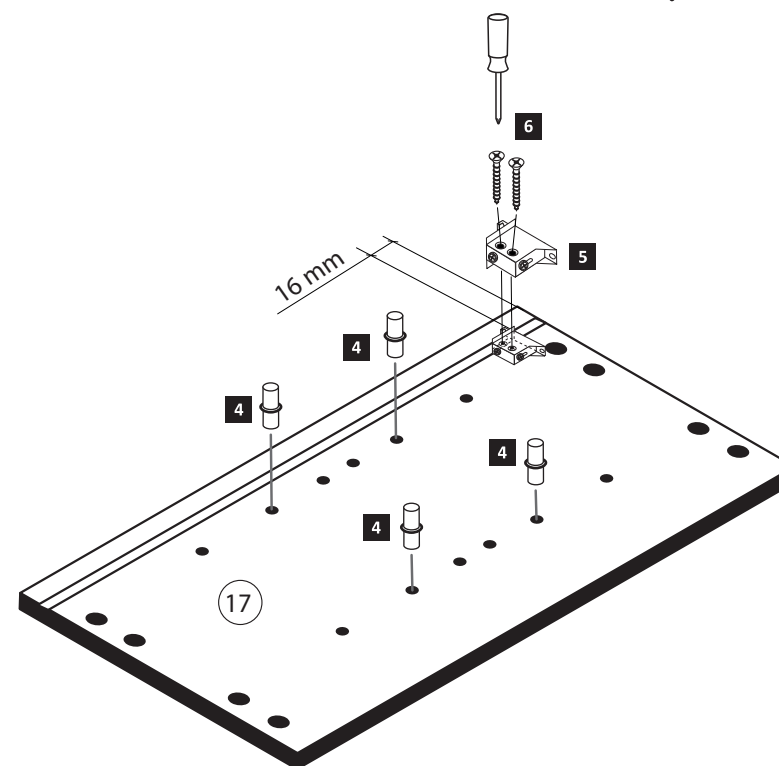
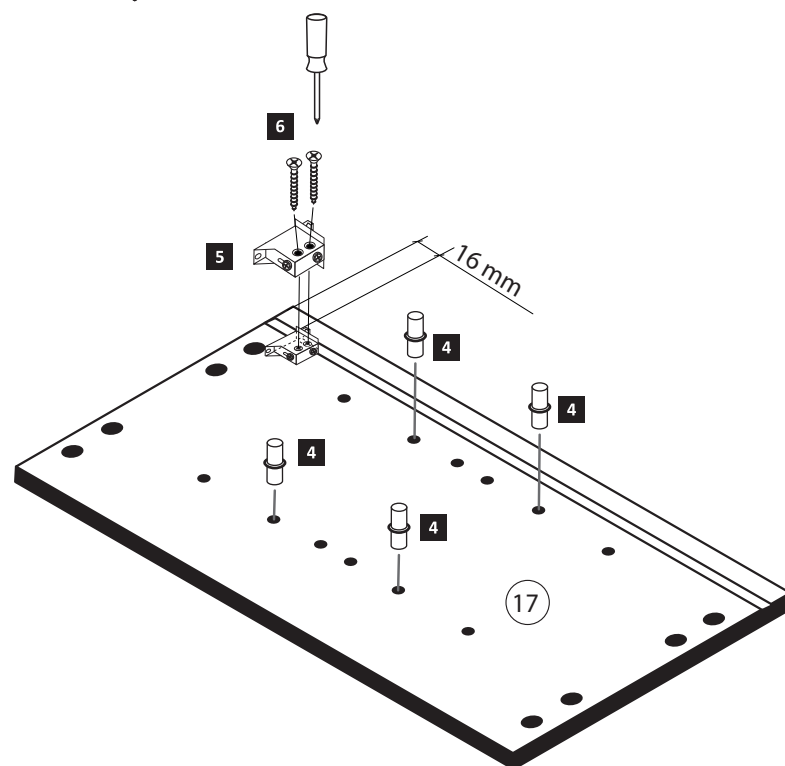

2



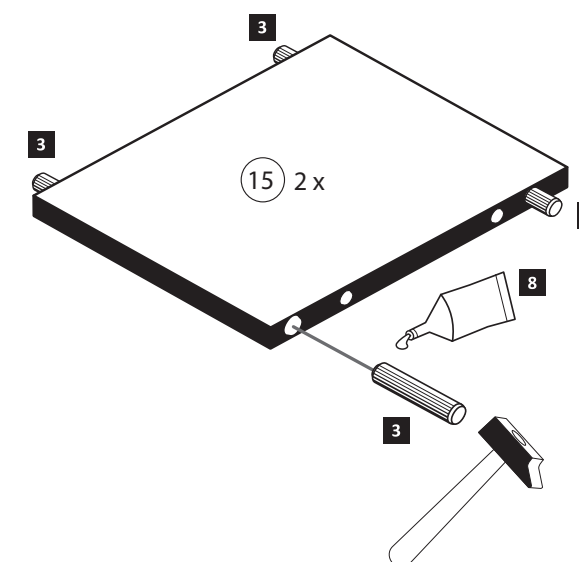

3 8 x 30 8 x 2861	8 1 x 2863
----------------------------	------------------

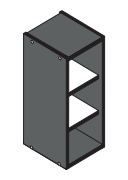

3



- | | | |
|----------|---|-------------|
| 1 |  | 8 x |
| 2 |  | 8 x
2827 |
| 8 |  | 1 x
2863 |
- 20 min.
- D Leim
GB Glue
NL Lijm
PL Klej
TR Tutkal
F Colle
I Colla

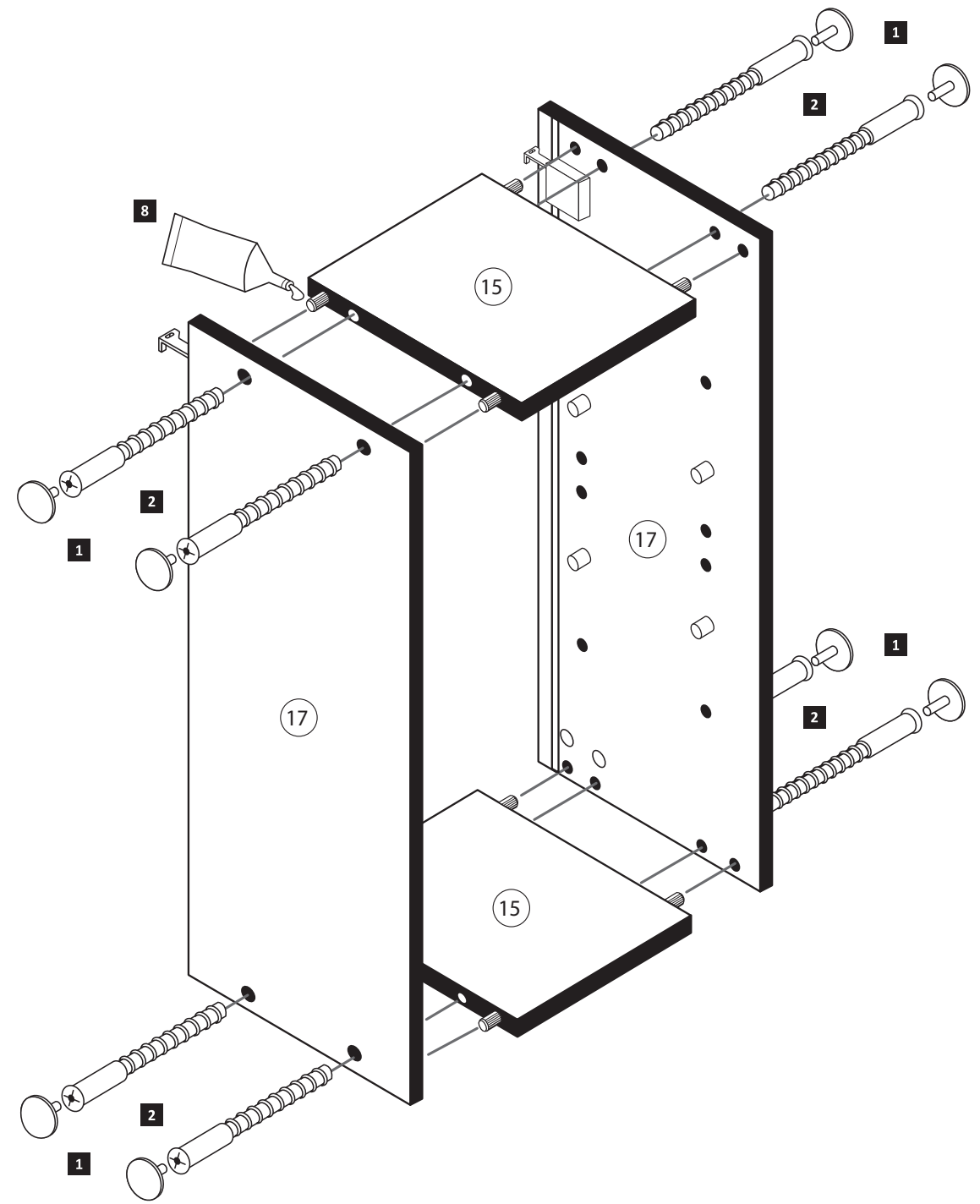

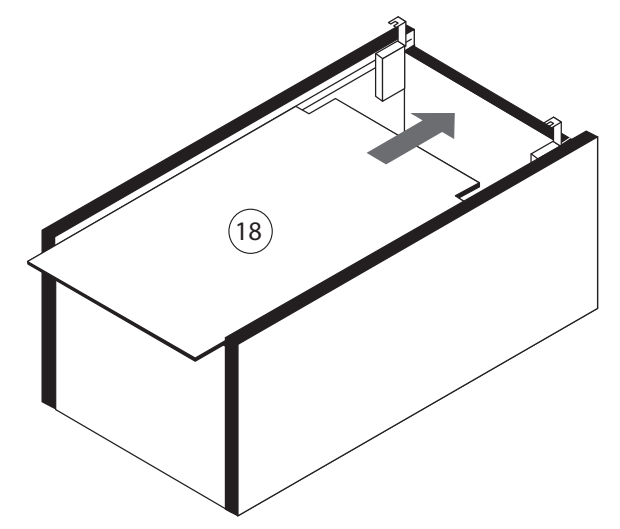
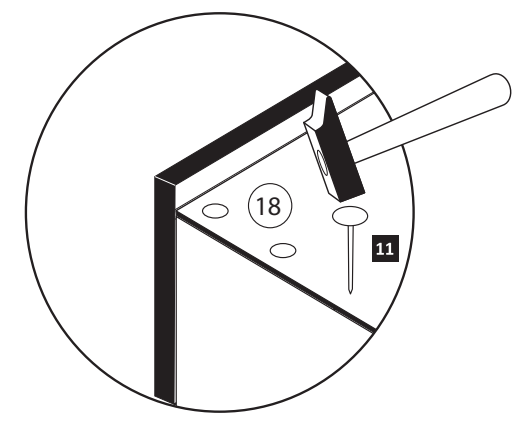

4

- | | | |
|-----------|---|--------------|
| 11 |  | 10 x
2862 |
|-----------|---|--------------|



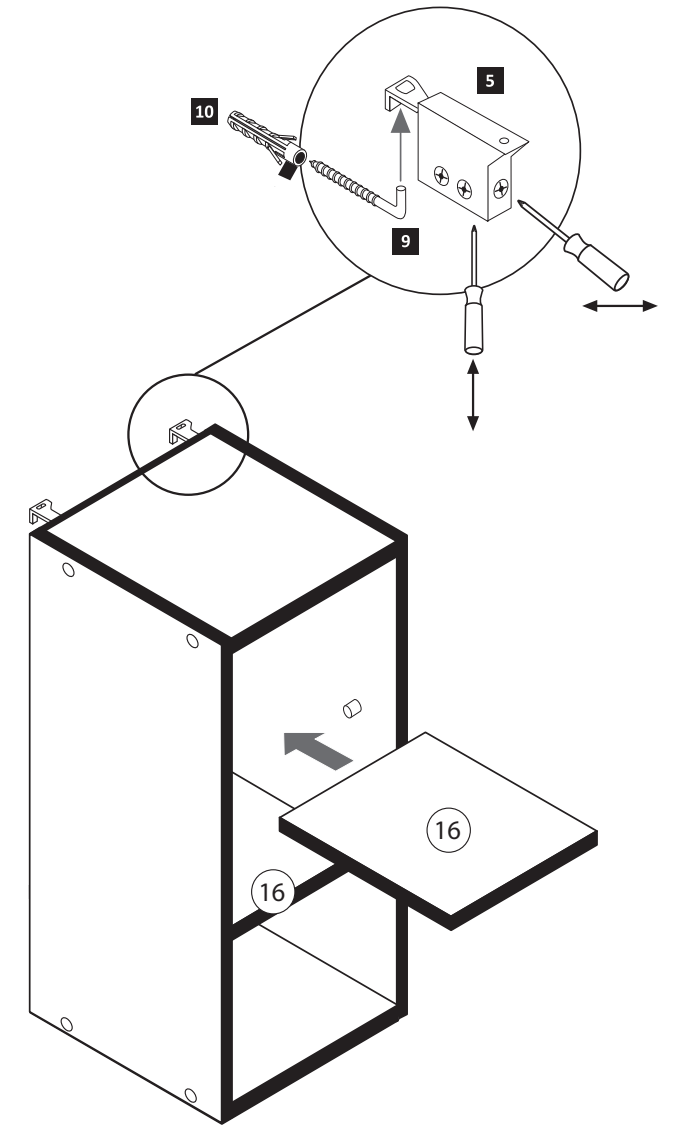

5

- | | | |
|-----------|---|-------------------------|
| 9 |  | 5,8 x 55
2 x
2840 |
| 10 |  | 8 x 30
2 x
2842 |



6

- | | | |
|----------|---|---------------|
| 7 |  | 4 x 9
2 x |
| |  | 5 x 30
1 x |

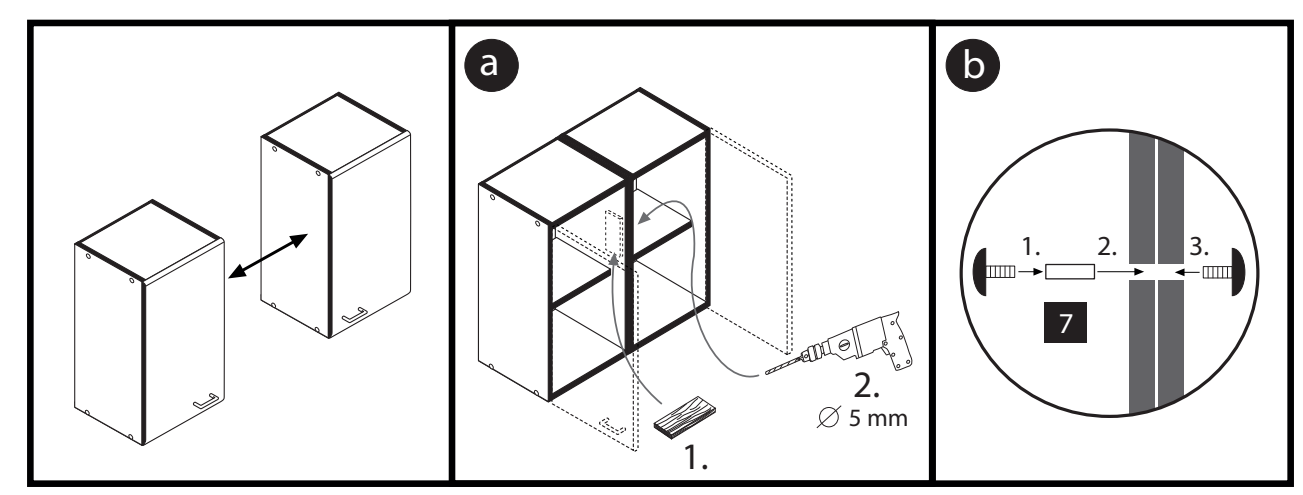



87015.330

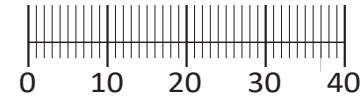
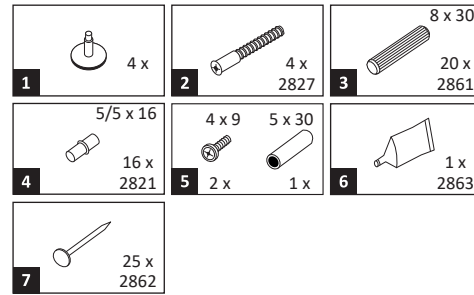
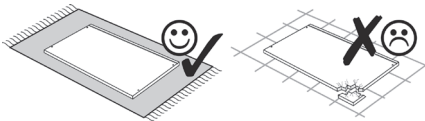
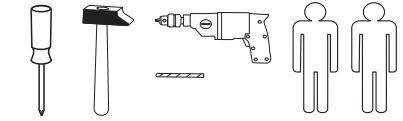
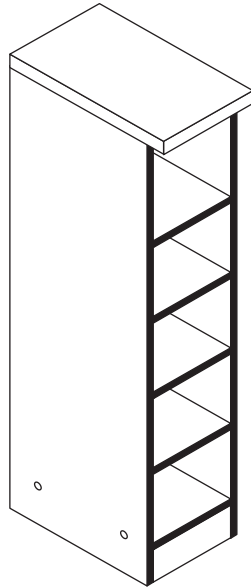

Das beigefügte Wandbefestigungsmaterial (Dübel und Schrauben) eignet sich nur für festes Mauerwerk (z.B.: Beton- oder Ziegelwände). Für andere Wandaufbauten sind eventuell Spezialdübel und andere Schrauben notwendig. Ziehen Sie gegebenenfalls eine Fachkraft zu Rate.

De begeleidende wandmontage hardware (pluggen en schroeven) is alleen geschikt voor massief metselwerk (bijvoorbeeld beton of bakstenen muren). Voor andere muur structuren zijn eventueel bijzondere ankerbouten en andere noodzakelijke. Draai indien nodig, een deskundige.

Приложенный материал для крепления к стене (дюбели и винты) пригоден только для жестких кладок (например, бетонные или кирпичные стены). Для других настенных конструкций необходимы смотря по обстоятельствам специальные дюбели и другие винты. При необходимости проконсультируйтесь у специалиста.

Le mur d'accompagnement matériel de montage (chevilles et les vis) ne convient que pour la maçonnerie solide (par exemple en béton ou des murs de briques). Pour les structures de mur d'autres sont peut-être spéciale boulons d'ancrage et d'autres nécessaires. Serrer le cas échéant, un expert.

Załączony materiał do mocowania do ściany (kolki rozprężne i wkręty) nadaje się tylko do ścian murowanych (np. z betonu lub cegiel). Do ścian wykonanych w innych technologiach konieczne być mogą specjalne kolki rozprężne i inne wkręty. W razie potrzeby skorzystaj z fachowej pomocy

Il muro di accompagnamento hardware di montaggio (tasselli e viti) è adatto solo per muratura piena (ad esempio calcestruzzo o muratura). Per le altre strutture murarie sono forse speciali bulloni di ancoraggio e necessari di altri. Serrare se necessario, un esperto.

The accompanying wall mounting hardware (anchors and screws) is suitable only for solid masonry (eg concrete or brick walls). For other wall structures are possibly special anchor bolts and other necessary. Tighten if necessary, an expert.

Ekteki duvara sabit montaj malzemeleri (dübel ve vidalar), sadece sağlam duvarlar için (örnek: beton veya tuğla) elverişlidir. Başka duvarlar için özel dübeller ve farklı vidalar gerekebilir. Gerektiğinde bir uzmana danışınız.

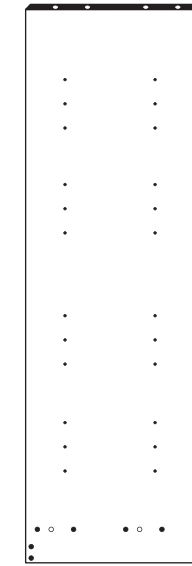

10 1 x



11 1 x

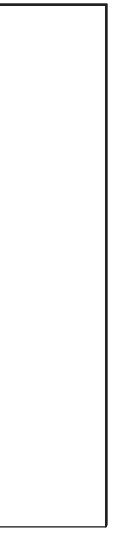

12 1 x



13 1 x



14 4 x

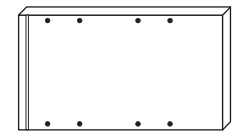

15 1 x



16 1 x

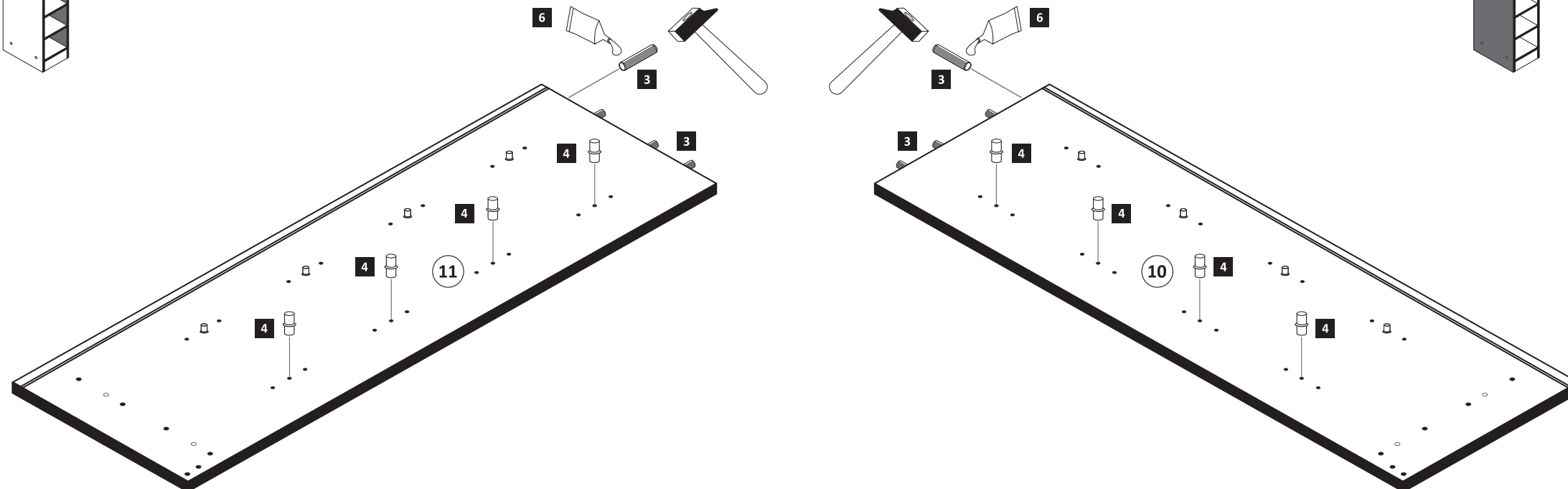
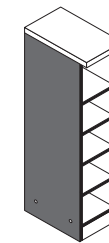
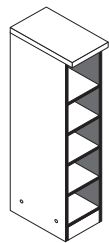
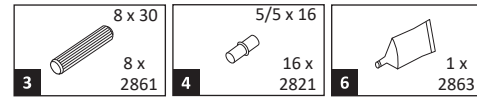

1

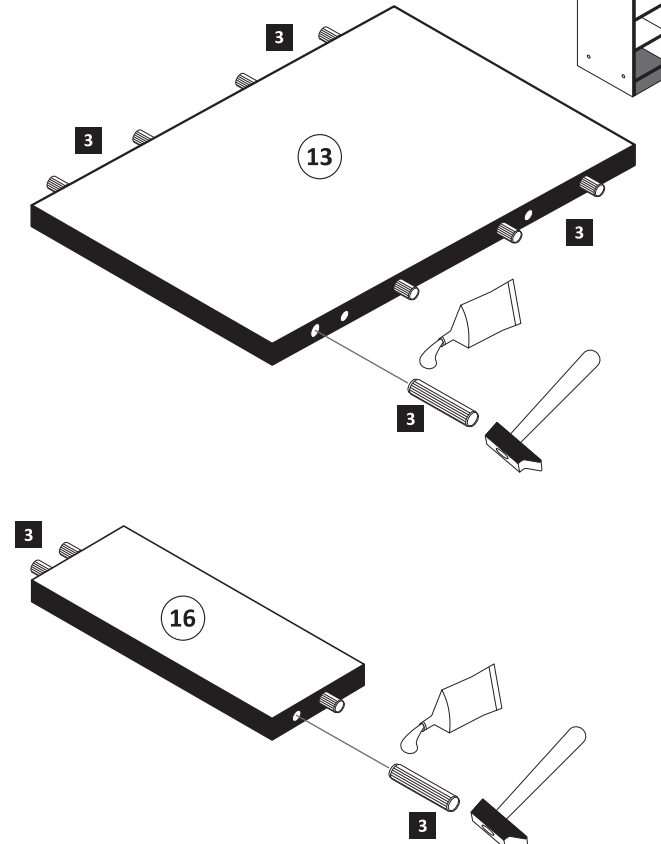
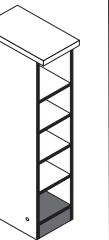
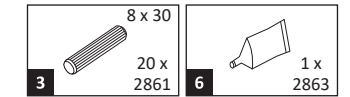

2



3

- 1  4 x
- 2  4 x 2827

- 6  1 x 2863
- D Leim
GB Glue
NL Lijm
PL Klej
TR Tutkal
F Colle
I Colla
- 20 min.

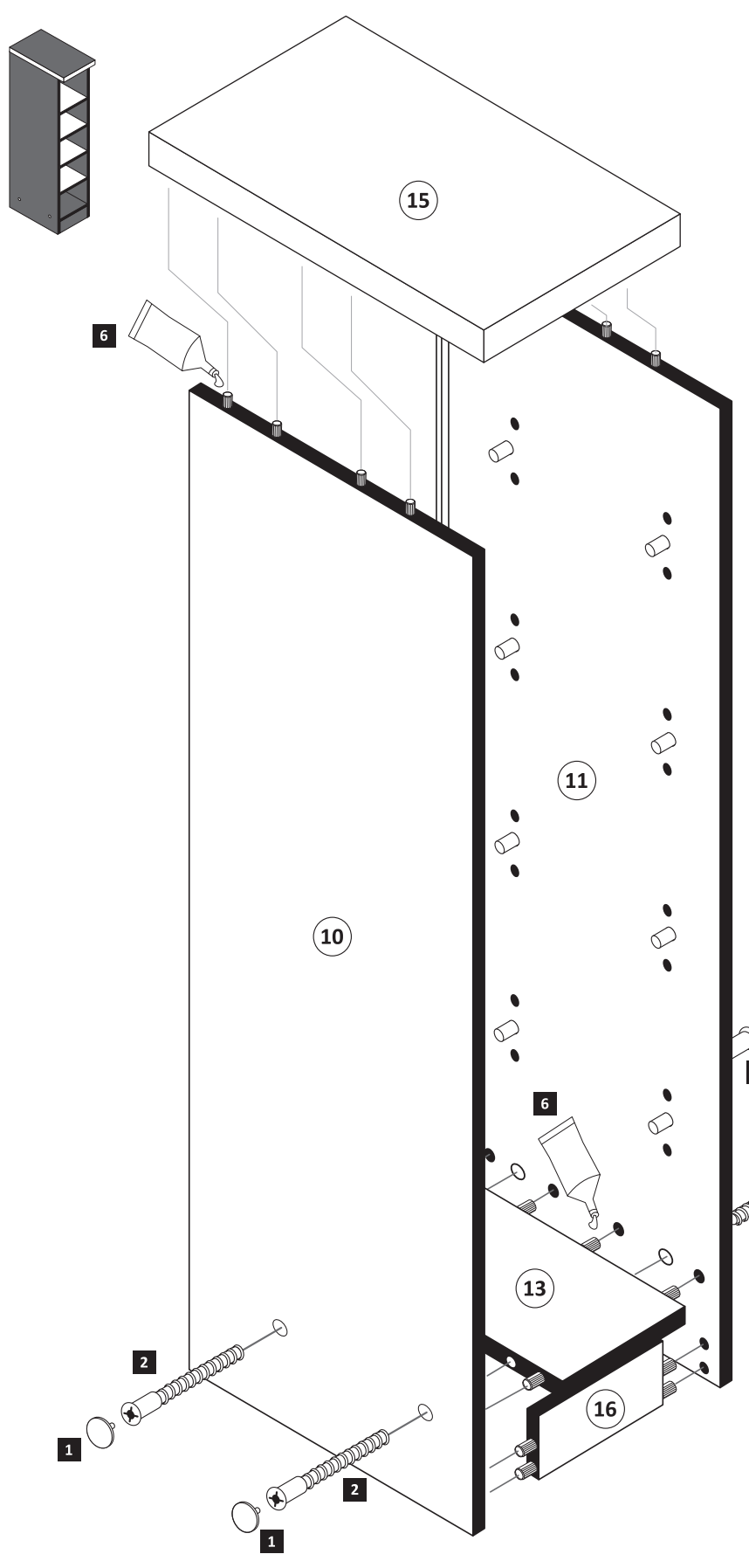

4

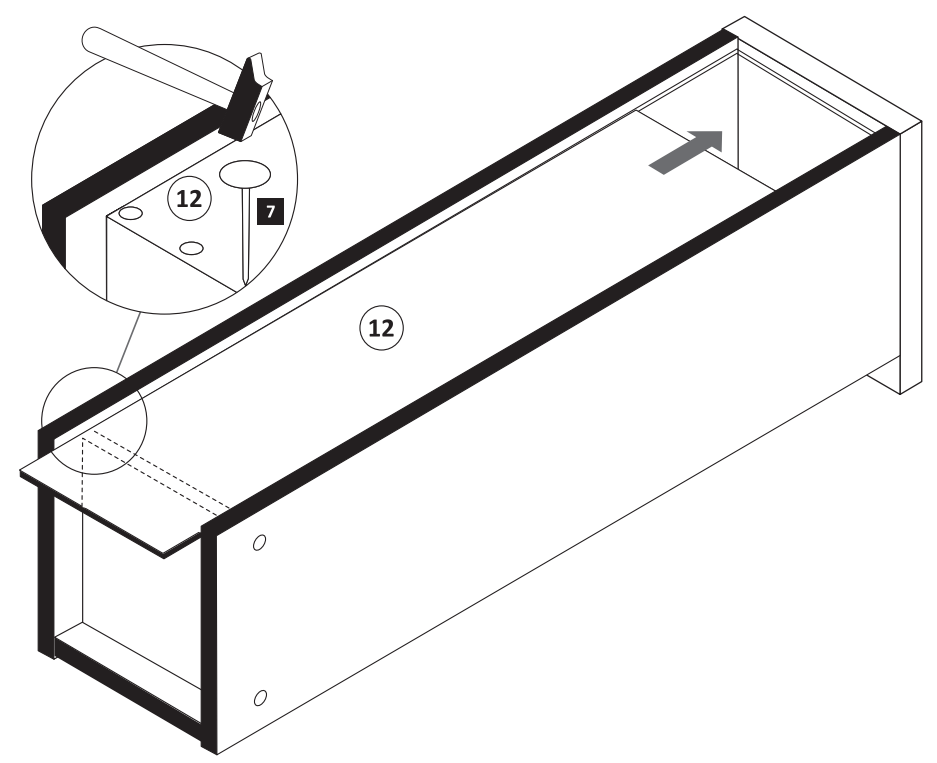

- 7  25 x 2862

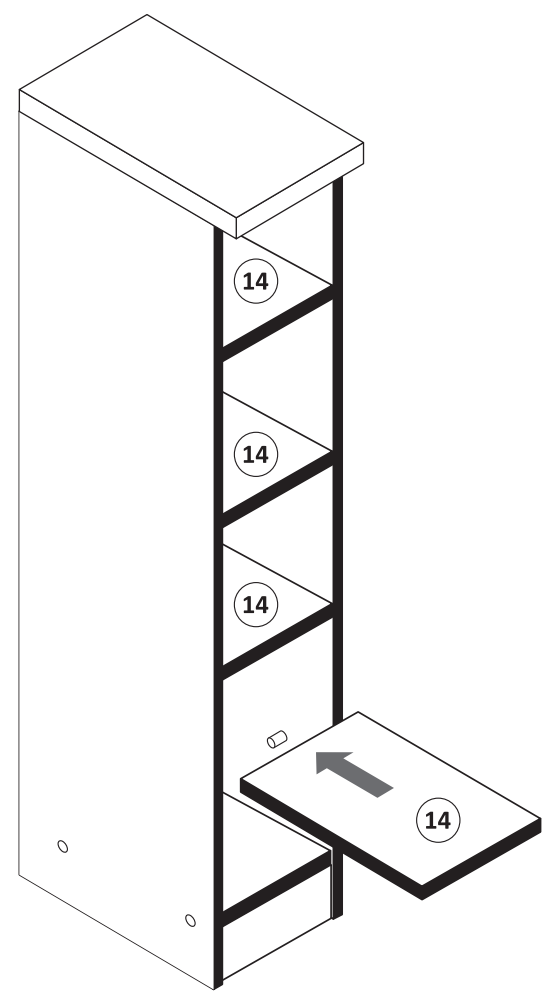
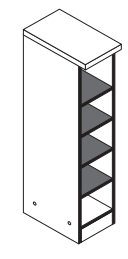

5



6

- 5  4 x 9 2 x
- 1  5 x 30 1 x

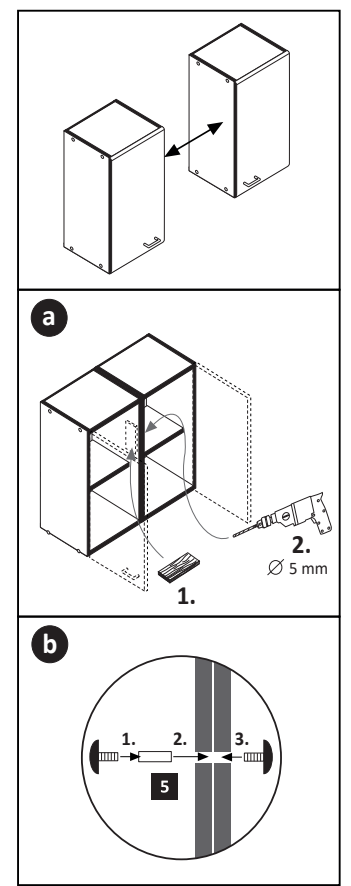



87263.350

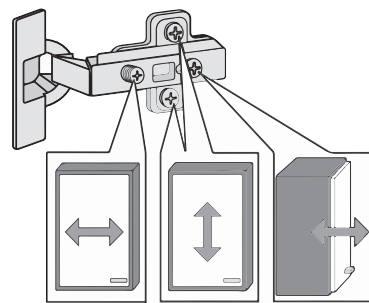
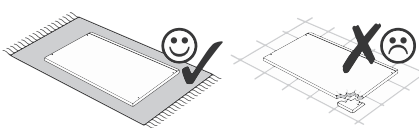
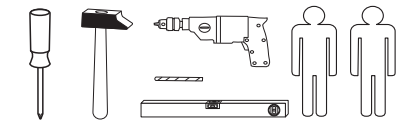

1 6 x 2827	2 6 x	3 8 x 30 22 x 2861	4 6,3 x 11 18 x 2815	5 4,0 x 22 2 x 2836
6 1 x	7 4,0 x 45 1 x 2814	8 6 x 34 1 x 2844	9 1 x	10 3,5 x 15 25 x 2804
11 4 x 9 2 x	12 5 x 30 1 x	13 1 x	14 3 x 5283.500	15 3 x 5283.500
16 4 x 2865	17 3 x 13,5 12 x 1123	18 4,5 x 15 1 x 2805		

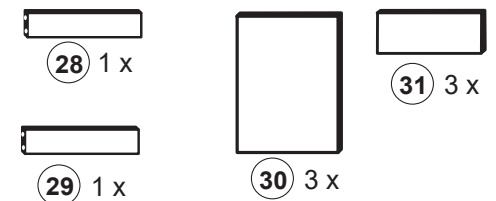
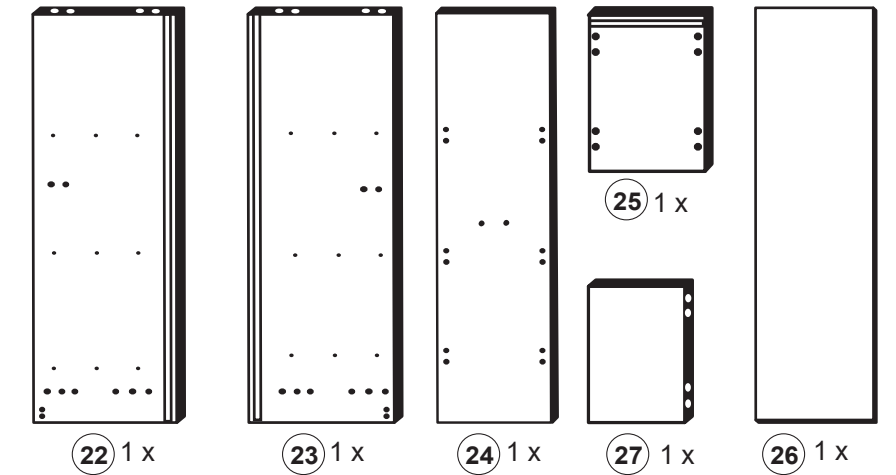
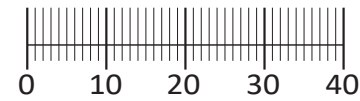

Das beigegefügte Wandbefestigungsmaterial (Dübel und Schrauben) eignet sich nur für festes Mauerwerk (z.B.: Beton- oder Ziegelwände). Für andere Wandaufbauten sind eventuell Spezialdübel und andere Schrauben notwendig. Ziehen Sie gegebenenfalls eine Fachkraft zu Rate.

De beigeleidende wandmontage hardware (pluggen en schroeven) is alleen geschikt voor massief metselwerk (bijvoorbeeld beton of bakstenen muren). Voor andere muur structuren zijn eventueel bijzondere ankerbouten en andere noodzakelijke. Draai indien nodig, een deskundige.

Приложенный материал для крепления к стене (дюбели и винты) пригоден только для жестких кладок (например, бетонные или кирпичные стены). Для других настенных конструкций необходимы смотря по обстоятельствам специальные дюбели и другие винты. При необходимости проконсультируйтесь у специалиста.

Le mur d'accompagnement matériel de montage (chevilles et les vis) ne convient que pour la maçonnerie solide (par exemple en béton ou des murs de briques). Pour les structures de mur d'autres sont peut-être spéciale boulons d'ancrage et d'autres nécessaires. Serrer le cas échéant, un expert.

Załączony materiał do mocowania do ściany (kolki rozprężne i wkręty) nadaje się tylko do ścian murowanych (np. z betonu lub cegiel). Do ścian wykonanych w innych technologiach konieczne być mogą specjalne kolki rozprężne i inne wkręty. W razie potrzeby skorzystaj z fachowej pomocy

Il muro di accompagnamento hardware di montaggio (tasselli e viti) è'e adatto solo per muratura piena (ad esempio calcestruzzo o muratura). Per le altre strutture murarie sono forse speciali bulloni di ancoraggio e necessari di altri. Serrare se necessario, un esperto.

The accompanying wall mounting hardware (anchors and screws) is suitable only for solid masonry (eg concrete or brick walls). For other wall structures are possibly special anchor bolts and other necessary. Tighten if necessary, an expert.

Ekteki duvara sabit montaj malzemeleri (dübel ve vidalar), sadece sağlam duvarlar için (örnek: beton veya tuğla) elverişlidir. Başka duvarlar için özel dübeller ve farklı vidalar gerekebilir. Gerektiğinde bir uzmana danışınız.

1

3 8 x 30 8 x 2861	4 6,3 x 11 18 x	13 1 x	15 3 x 5282.400
----------------------------	-----------------------	-----------	-----------------------

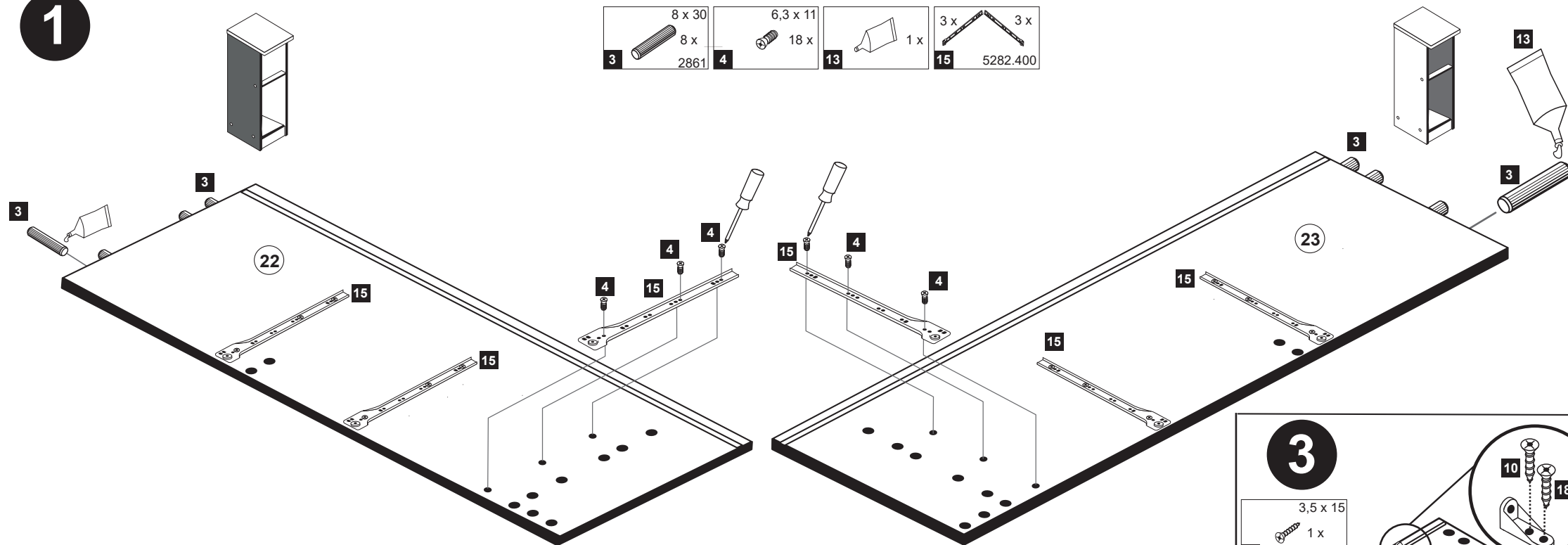

2

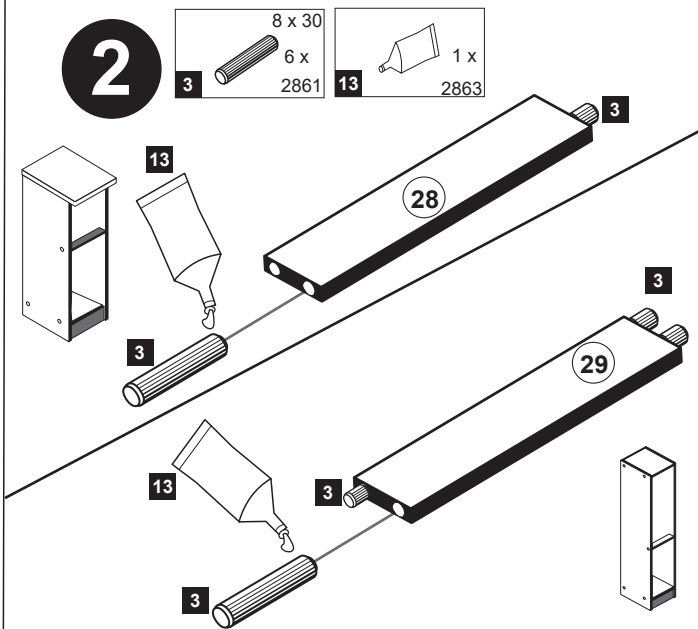

3

10 3,5 x 15 1 x 2804	18 4,5 x 15 1 x 2805
-------------------------------	-------------------------------

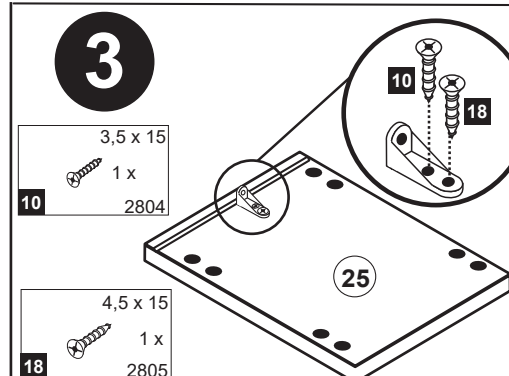

4

3 8 x 30 8 x 2861	13 1 x 2863
----------------------------	-------------------

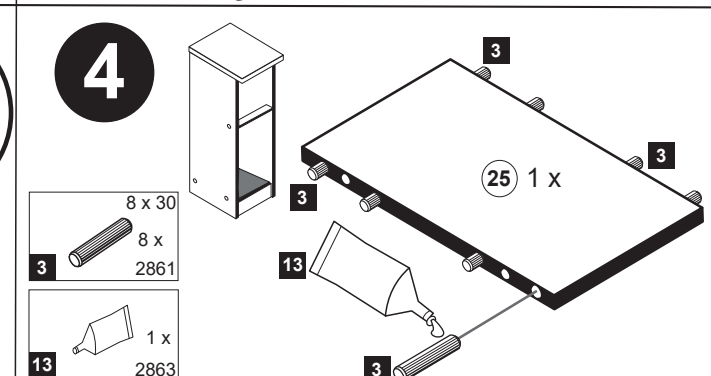

5

1 6 x 2827
2 6 x
13 1 x 2863
 D Leim
 GB Glue
 NL Lijm
 PL Klej
 TR Tutkal
 F Colle
 I Colla
 20 min.

7

14 3 x 5283.500
15 3 x 5283.500

8

10 3,5 x 15 24 x 2804

9

16 4 x 2865
17 3 x 13,5 12 x 1123

6

12 25 x 2862

10

5 4,0 x 22 2 x 2836
6 1 x

11

7 4,0 x 45 1 x 2814
8 6 x 34 1 x 2844
9 1 x 2845

Achtung! Innen-Ansicht.

Tipp!
 Für ein gleichmäßiges Fugenbild können Sie die Auszüge in der Höhe einstellen. Drehen Sie hierfür die große Stellschraube nach rechts bzw. nach links. Der Auszug bewegt sich dann nach oben bzw. nach unten.



87020.530



1	8 x	2	8 x	3	2 x	4	2 x	5	1 x
		2827		1503	1611				
6	2 x	7	2 x	8	4 x	9	4 x	10	2 x
			1 x		2804				
11	4 x	12	2 x		2 x	13	1 x		1 x
	2821	2840	2842	2881	2880				
14	10 x	15		24	8 x	25	1 x		
	2862	2865	2861	2863					



Das beigefügte Wandbefestigungsmaterial (Dübel und Schrauben) eignet sich nur für festes Mauerwerk (z.B. Beton- oder Ziegelwände). Für andere Wandaufbauten sind eventuell Spezialdübel und andere Schrauben notwendig. Ziehen Sie gegebenenfalls eine Fachkraft zu Rate.

De begeleidende wandmontage hardware (pluggen en schroeven) is alleen geschikt voor massief metselwerk (bijvoorbeeld beton of bakstenen muren). Voor andere muur structuren zijn eventueel bijzondere ankerbouten en andere noodzakelijke. Draai indien nodig, een deskundige.

Приложенный материал для крепления к стене (дюбели и винты) пригоден только для жестких кладок (например, бетонные или кирпичные стены). Для других настенных конструкций необходимы смотря по обстоятельствам специальные дюбели и другие винты. При необходимости проконсультируйтесь у специалиста.

Le mur d'accompagnement matériel de montage (chevilles et les vis) ne convient que pour la maçonnerie solide (par exemple en béton ou des murs de briques). Pour les structures de mur d'autres sont peut-être spéciale boulons d'ancrage et d'autres nécessaires. Serrer le cas échéant, un expert.

Załączony materiał do mocowania do ściany (kolki rozprężne i wkręty) nadaje się tylko do ścian murowanych (np. z betonu lub cegieł). Do ścian wykonanych w innych technologiach konieczne być mogą specjalne kolki rozprężne i inne wkręty. W razie potrzeby skorzystaj z fachowej pomocy

Il muro di accompagnamento hardware di montaggio (tasselli e viti) è adatto solo per muratura piena (ad esempio calcestruzzo o muratura). Per le altre strutture murarie sono forse speciali bulloni di ancoraggio e necessari di altri. Serrare se necessario, un esperto.

The accompanying wall mounting hardware (anchors and screws) is suitable only for solid masonry (eg concrete or brick walls). For other wall structures are possibly special anchor bolts and other necessary. Tighten if necessary, an expert.

Ekteki duvara sabit montaj malzemeleri (dübel ve vidalar), sadece sağlam duvarlar için (örnek: beton veya tuğla) elverişlidir. Başka duvarlar için özel dübeller ve farklı vidalar gerekebilir. Gerektiğinde bir uzmana danışınız.

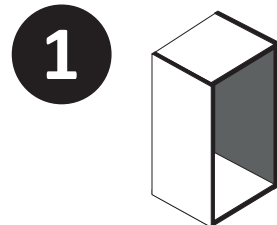
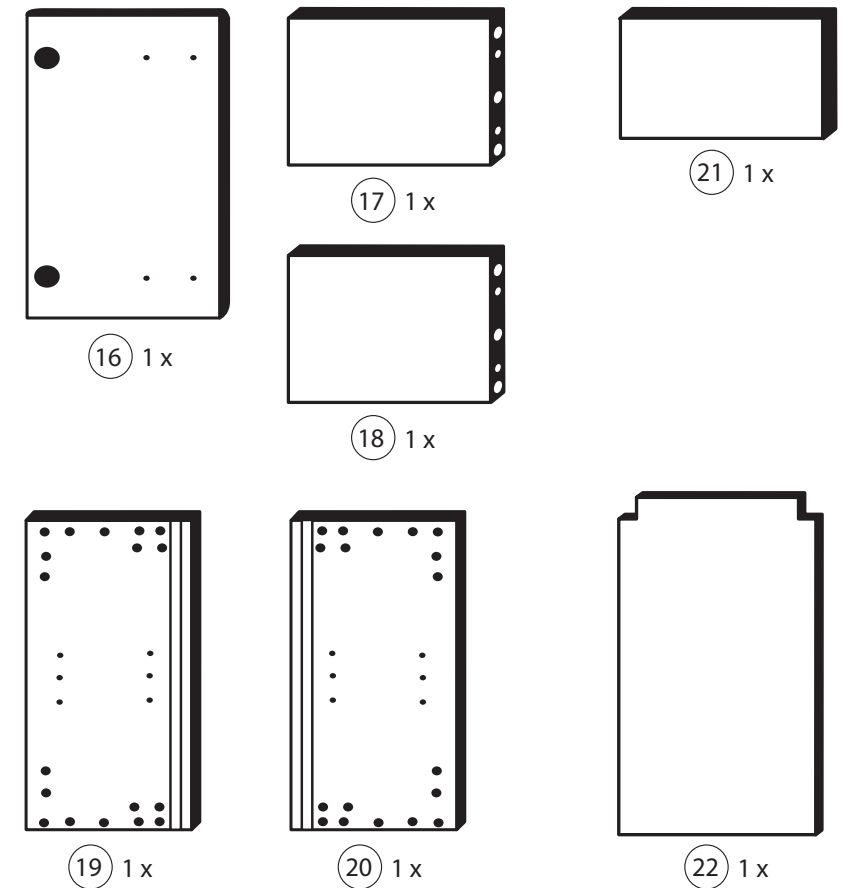

4	2 x	11	4 x	9	4 x	13	1 x		1 x
	1611	2821	2821			2880	2881		

Bitte beachten!
In dieser Aufbauanleitung ist die Tür rechts angeschlagen.
Soll die Tür links angeschlagen werden, müssen die Kreuzmontageplatten 4 auf das linke Seitenteil 19 und die Scharniere 3 die gegenüberliegenden Bohrungen montiert werden.

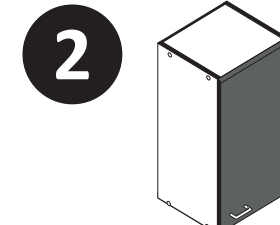
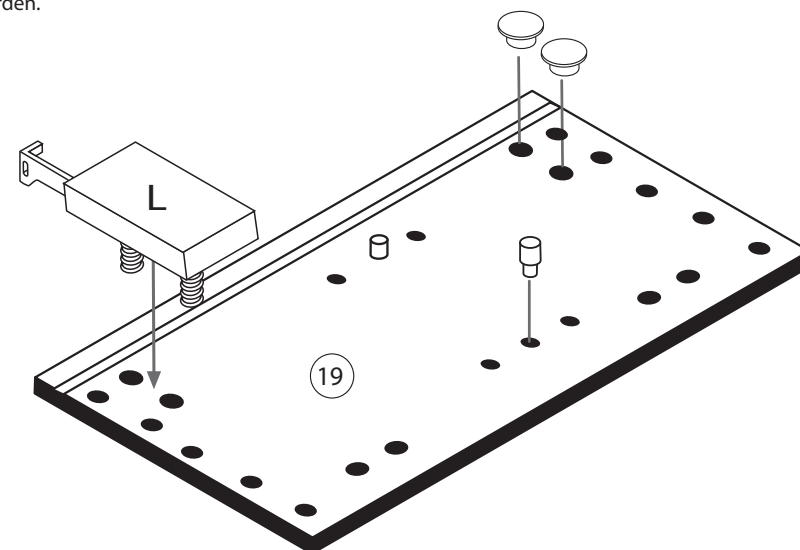

3	2 x	15	
	1503	2865	
8	4 x		
	2804		

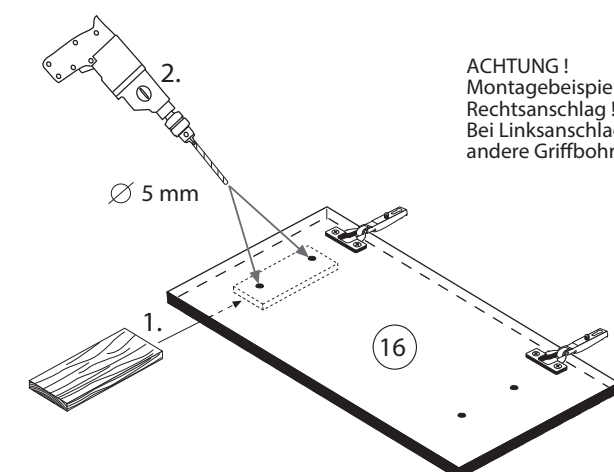
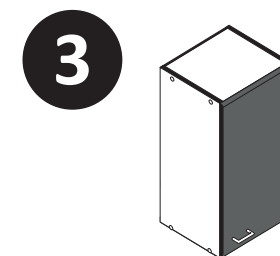
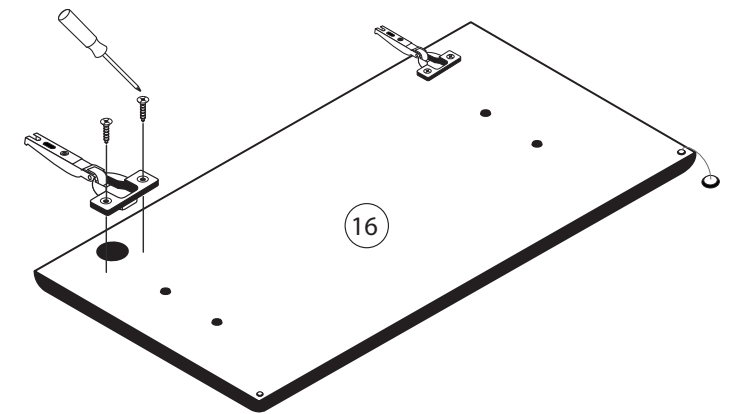

ACHTUNG!
Montagebeispiel
Rechtsanschlag!
Bei Linksanschlag
andere Griffbohrung durchbohren!

4

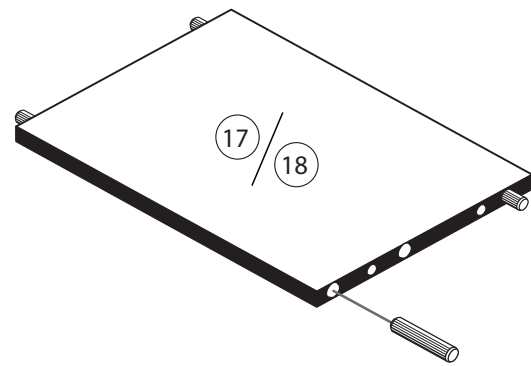

24	8 x 30 8 x 2861	25	1 x 2863
D Leim GB Glue NL Lijm PL Klej TR Tutkal F Colle I Colla			
20 min.			

5



1	8 x	25	1 x 2863
2	8 x 2827	D Leim GB Glue NL Lijm PL Klej TR Tutkal F Colle I Colla	
20 min.			

7

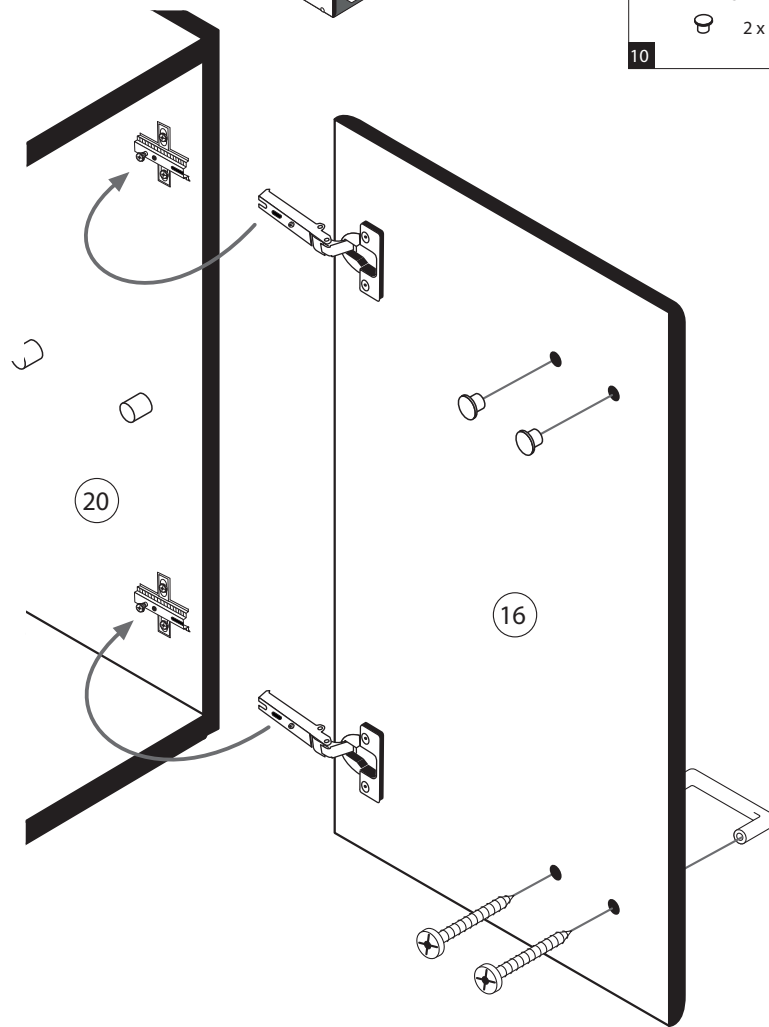
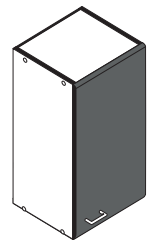

5	1 x
6	2 x
10	5mm 2 x

8

12	5,8 x 55 2 x 2840	8 x 30 2 x 2842
----	-------------------------	-----------------------

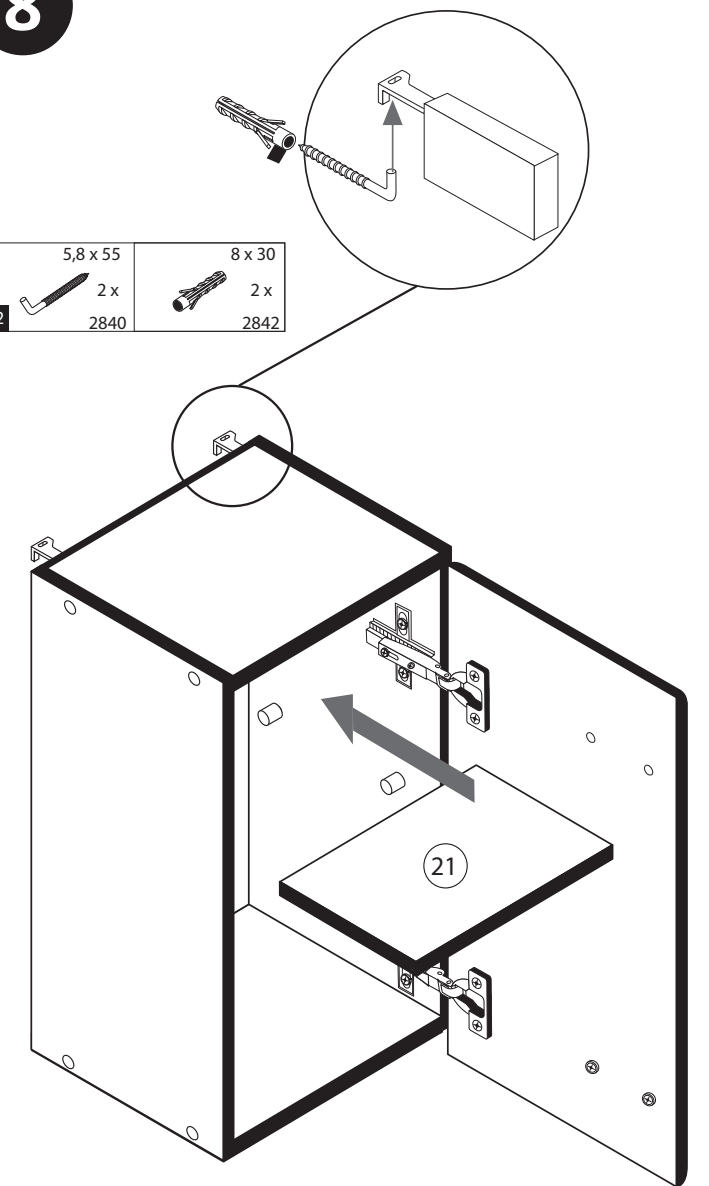

6

14	10 x 2862
----	--------------

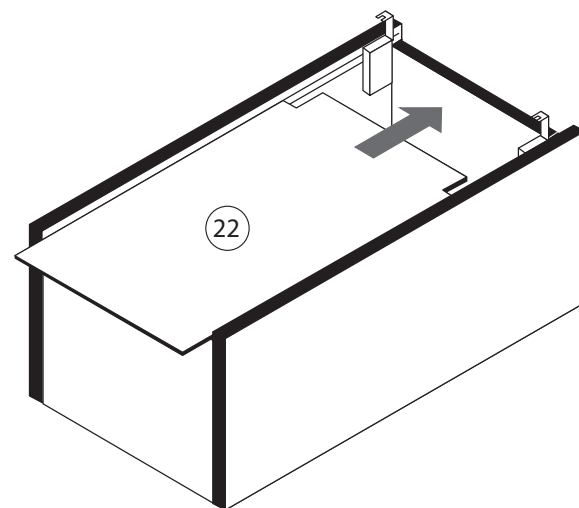
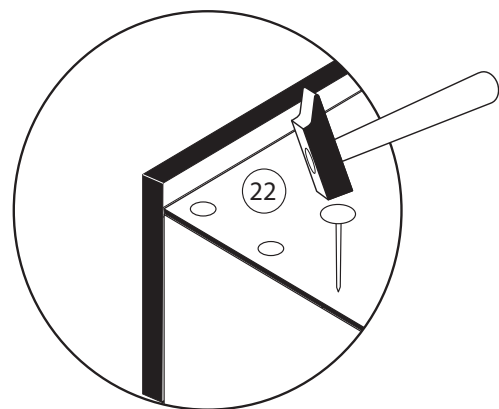

9

7	4 x 9 2 x	5 x 30 1 x
---	--------------	---------------

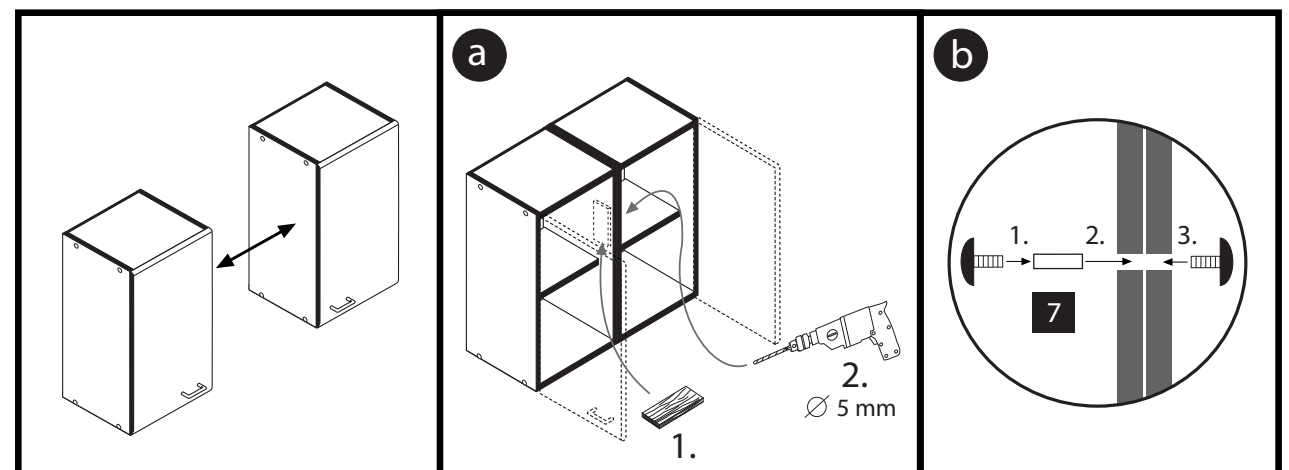



1 8 x 2827	2 8 x	3 3 x 1611	4 3 x 1503	5 3 x 1612	6 3 x 1502
7 3,5 x 15 12 x 2804	8 8 x 30 12 x 2861	9 8 x 30 2 x 2842	10 5,8 x 55 2 x 2840	11 R 1 x 2881	12 L 1 x 2880
13 2 x	14 4 x 2829	15 10mm 4 x 2885	16 8mm 2 x	22 4 x	
17 4 x 2865	18 25 x 2862	19 4 x 9 2 x	20 Leim 1 x 2863	21 4 x 5353	23 4 x
24 4 x 15 16 x 2810					

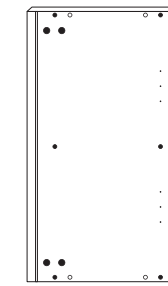
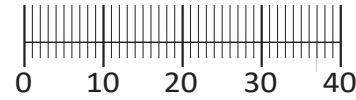

26 2 x

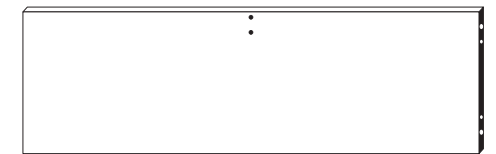

27 1 x

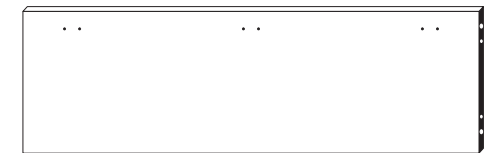

28 1 x

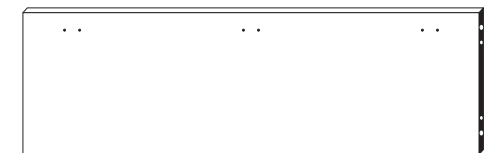

29 1 x

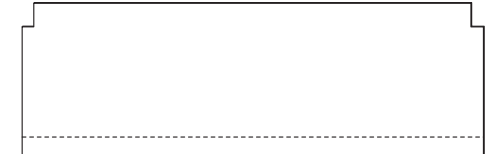

29 1 x

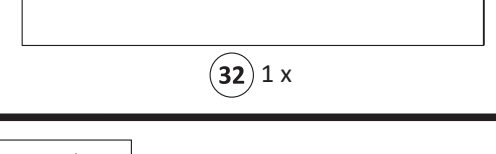

32 1 x

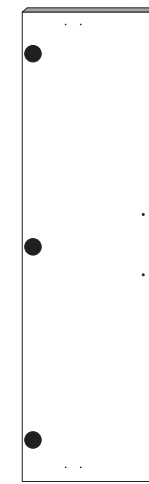

30 1 x

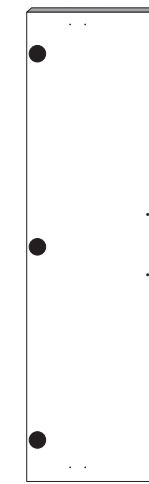

31 1 x

87053.730

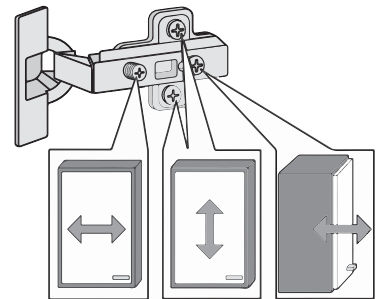
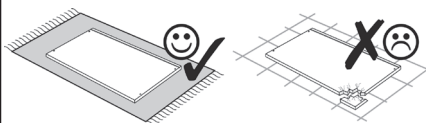
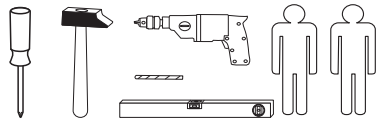

Das beigegefügte Wandbefestigungsmaterial (Dübel und Schrauben) eignet sich nur für festes Mauerwerk (z.B.: Beton- oder Ziegelwände). Für andere Wandaufbauten sind eventuell Spezialdübel und andere Schrauben notwendig. Ziehen Sie gegebenenfalls eine Fachkraft zu Rate.

Приложенный материал для крепления к стене (дюбели и винты) пригоден только для жестких кладок (например, бетонные или кирпичные стены). Для других настенных конструкций необходимы смотря по обстоятельствам специальные дюбели и другие винты. При необходимости проконсультируйтесь у специалиста.

Załączony materiał do mocowania do ściany (kolki rozprężne i wkręty) nadaje się tylko do ścian murowanych (np. z betonu lub cegieł). Do ścian wykonanych w innych technologiach konieczne być mogą specjalne kolki rozprężne i inne wkręty. W razie potrzeby skorzystaj z fachowej pomocy.

The accompanying wall mounting hardware (anchors and screws) is suitable only for solid masonry (eg concrete or brick walls). For other wall structures are possibly special anchor bolts and other necessary. Tighten if necessary, an expert.

De begeleidende wandmontage hardware (pluggen en schroeven) is alleen geschikt voor massief metselwerk (bijvoorbeeld beton of bakstenen muren). Voor andere muur structuren zijn eventueel bijzondere ankerbouten en andere noodzakelijke. Draai indien nodig, een deskundige.

Le mur d'accompagnement matériel de montage (chevilles et les vis) ne convient que pour la maçonnerie solide (par exemple en béton ou des murs de briques). Pour les structures de mur d'autres sont peut-être spéciale boulons d'ancrage et d'autres nécessaires. Serrer le cas échéant, un expert.

Il muro di accompagnamento hardware di montaggio (tasselli e viti) è adatto solo per muratura piena (ad esempio calcestruzzo o muratura). Per le altre strutture murarie sono forse speciali bulloni di ancoraggio e necessari di altri. Serrare se necessario, un esperto.

Ekteki duvara sabit montaj malzemeleri (dübel ve vidalar), sadece sağlam duvarlar için (örnek: beton veya tuğla) elverişlidir. Başka duvarlar için özel dübeller ve farklı vidalar gerekebilir. Gerektiğinde bir uzmana danışınız.

1

11 R 1 x 2881	12 L 1 x 2880	15 10mm 4 x 2885	23 4 x	24 4 x 15 8 x 2810
------------------------	------------------------	---------------------------	-----------	-----------------------------

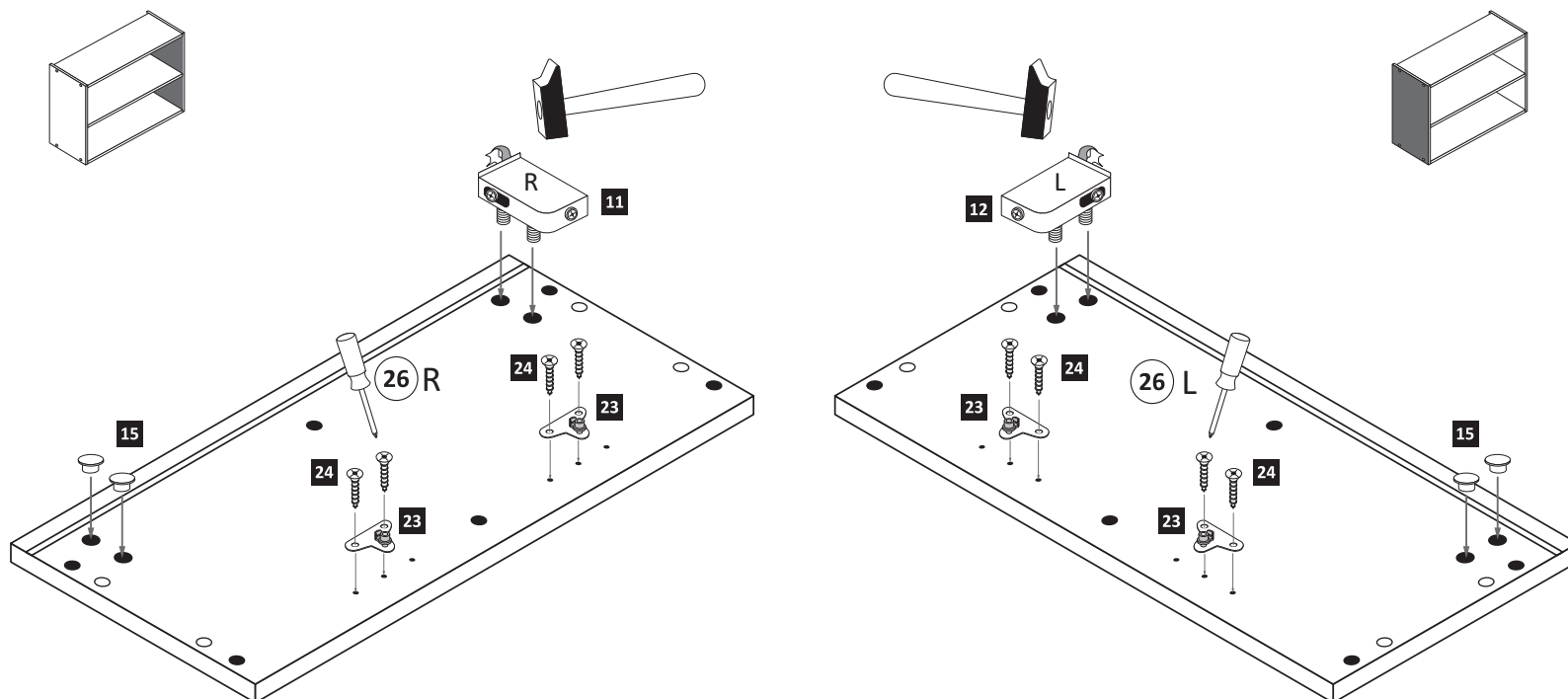

2

3 3 x 1611	5 3 x 1612	8 8 x 30 12 x 2861	16 8mm 2 x	20 Leim 1 x 2863
------------------	------------------	-----------------------------	------------------	---------------------------

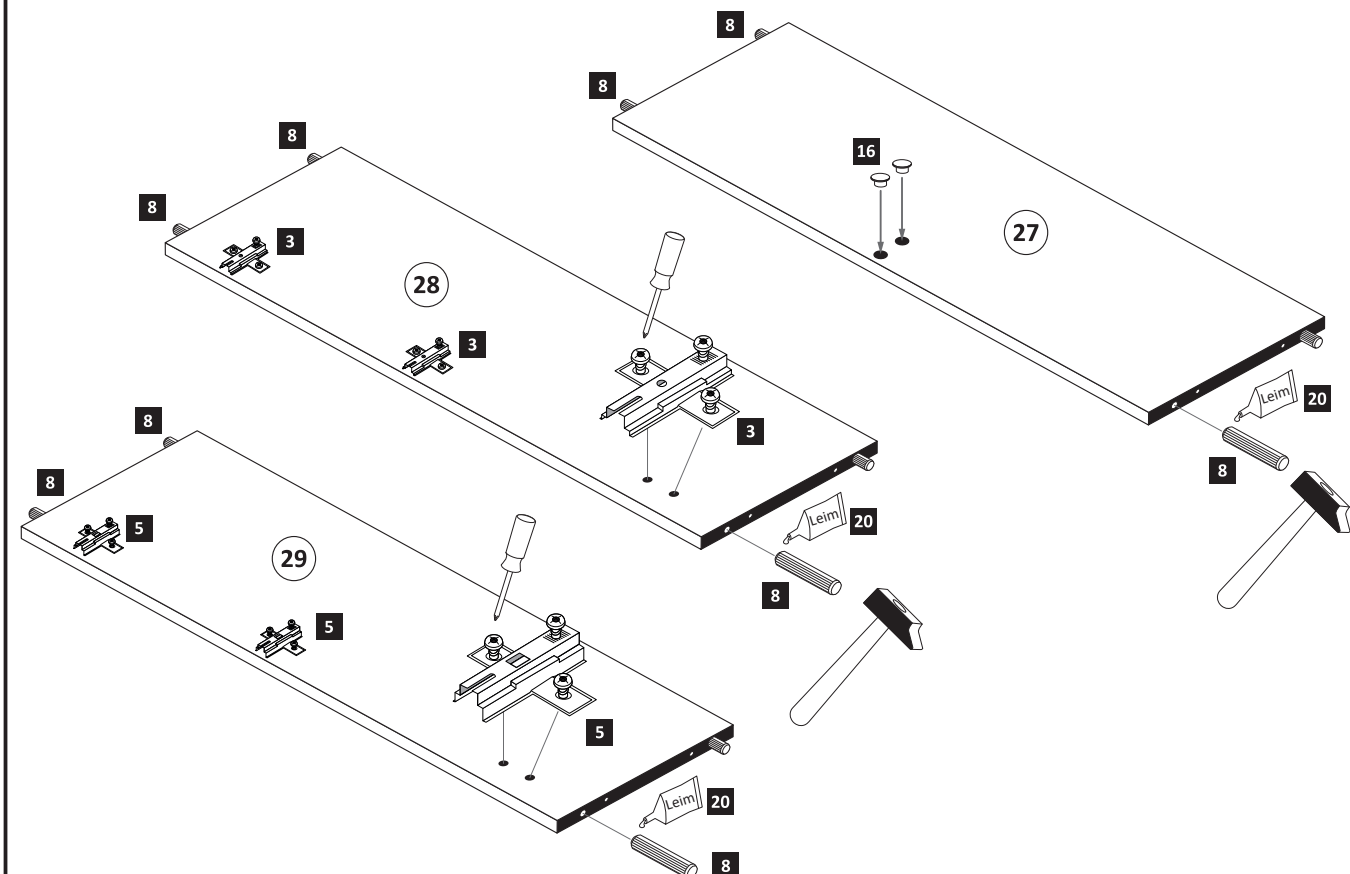

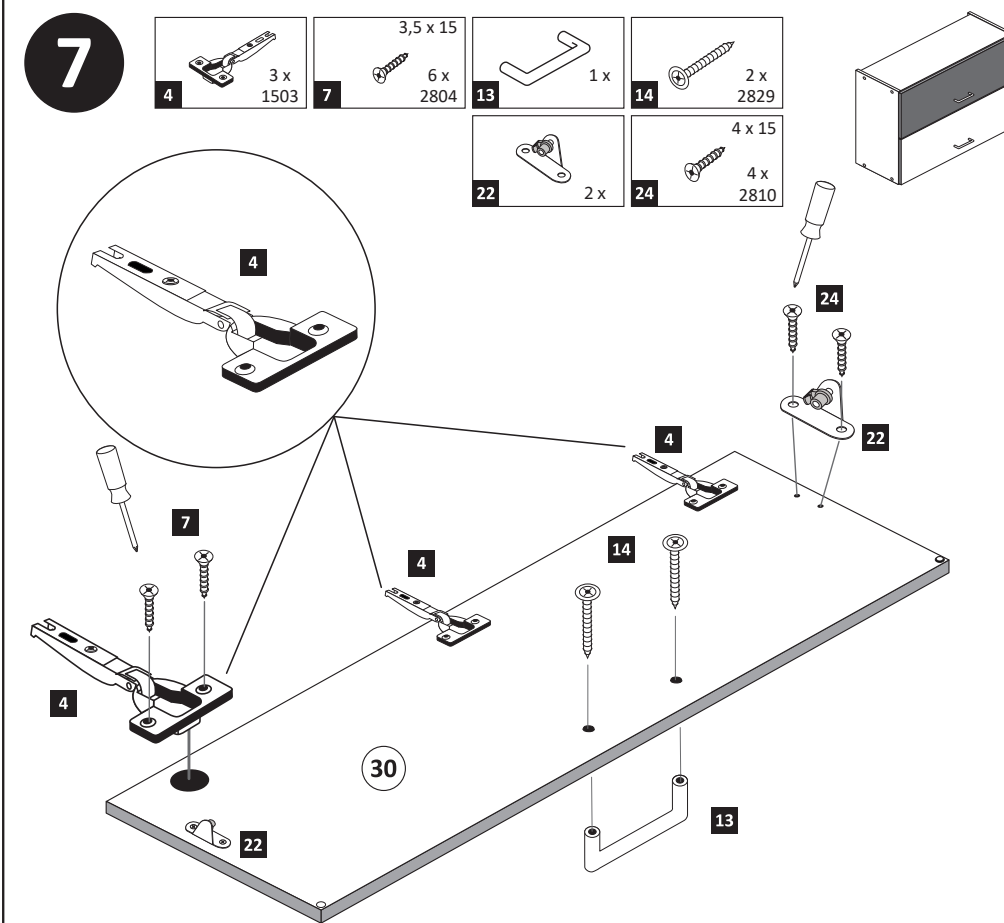
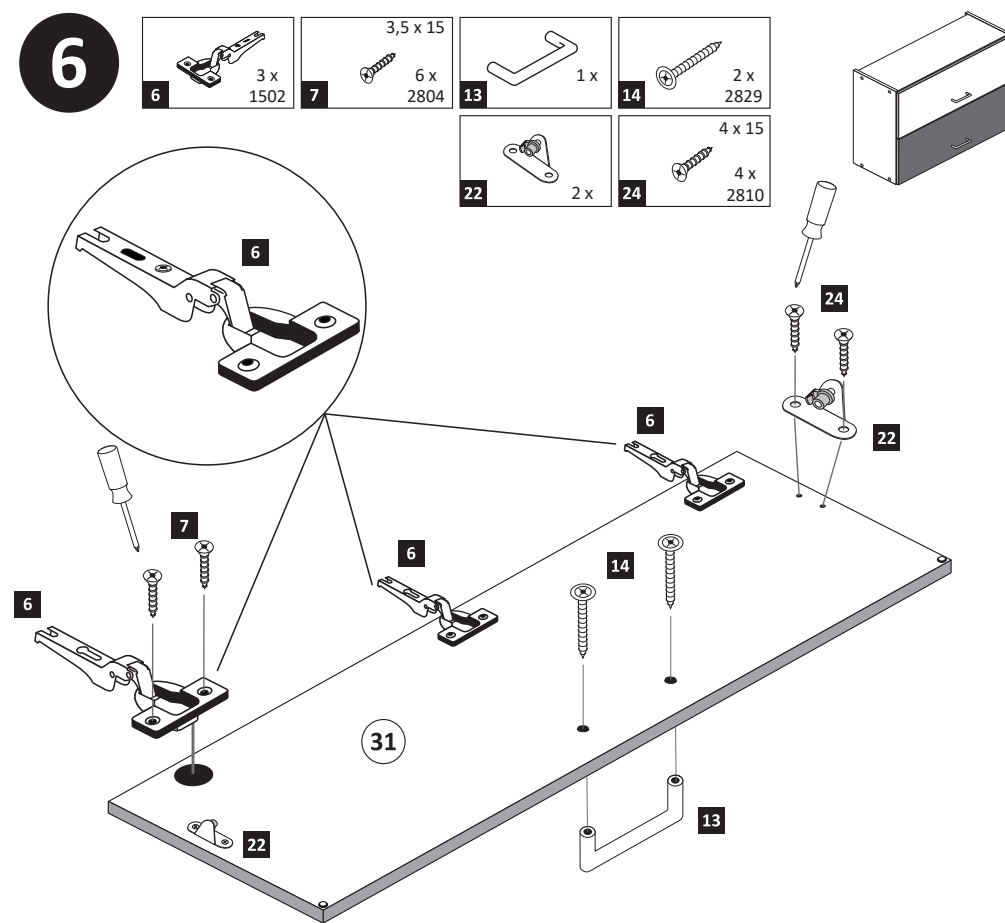
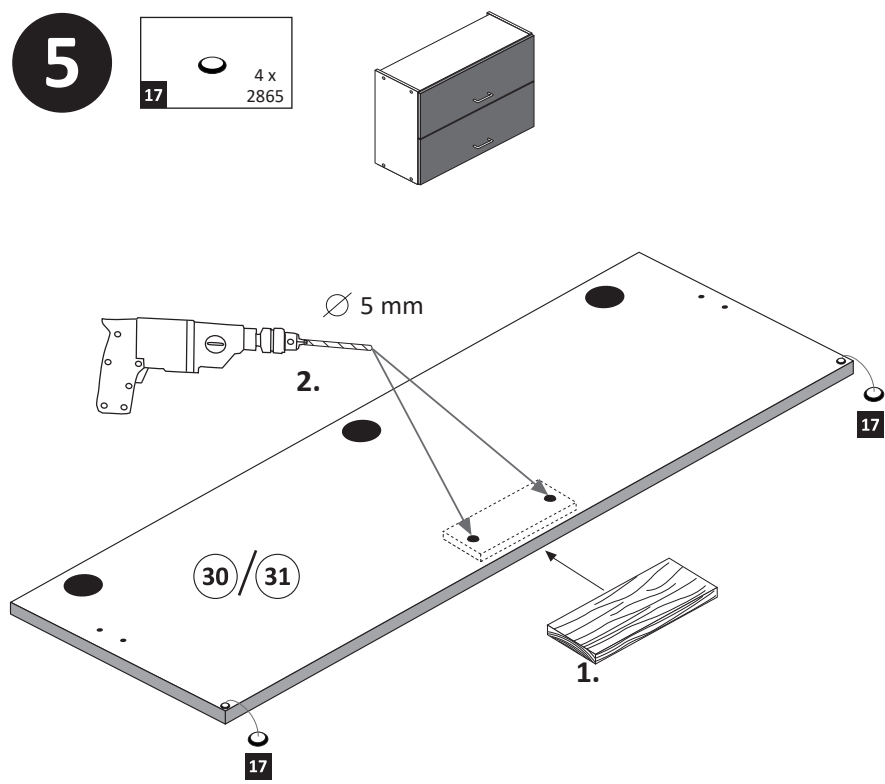
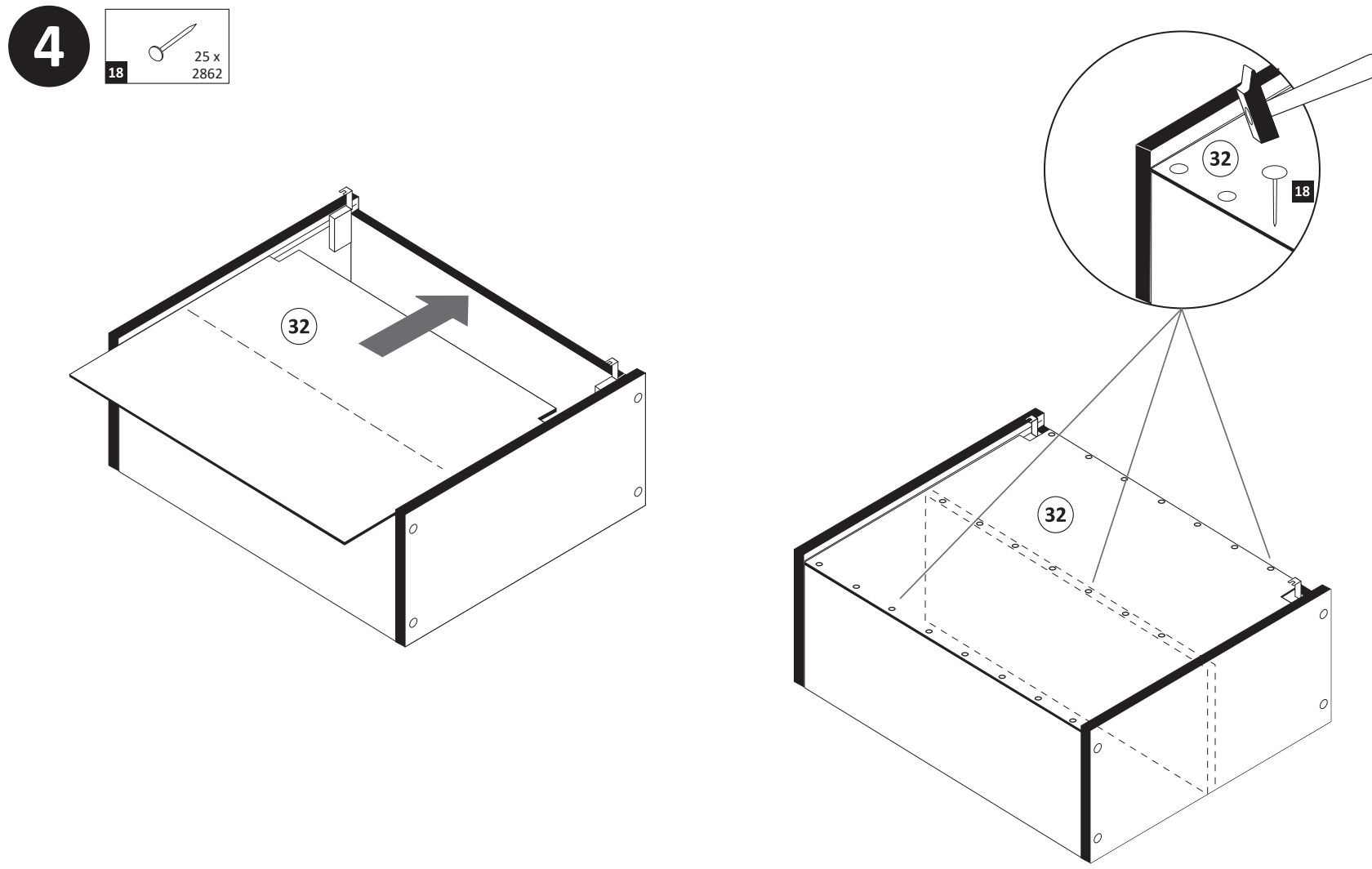
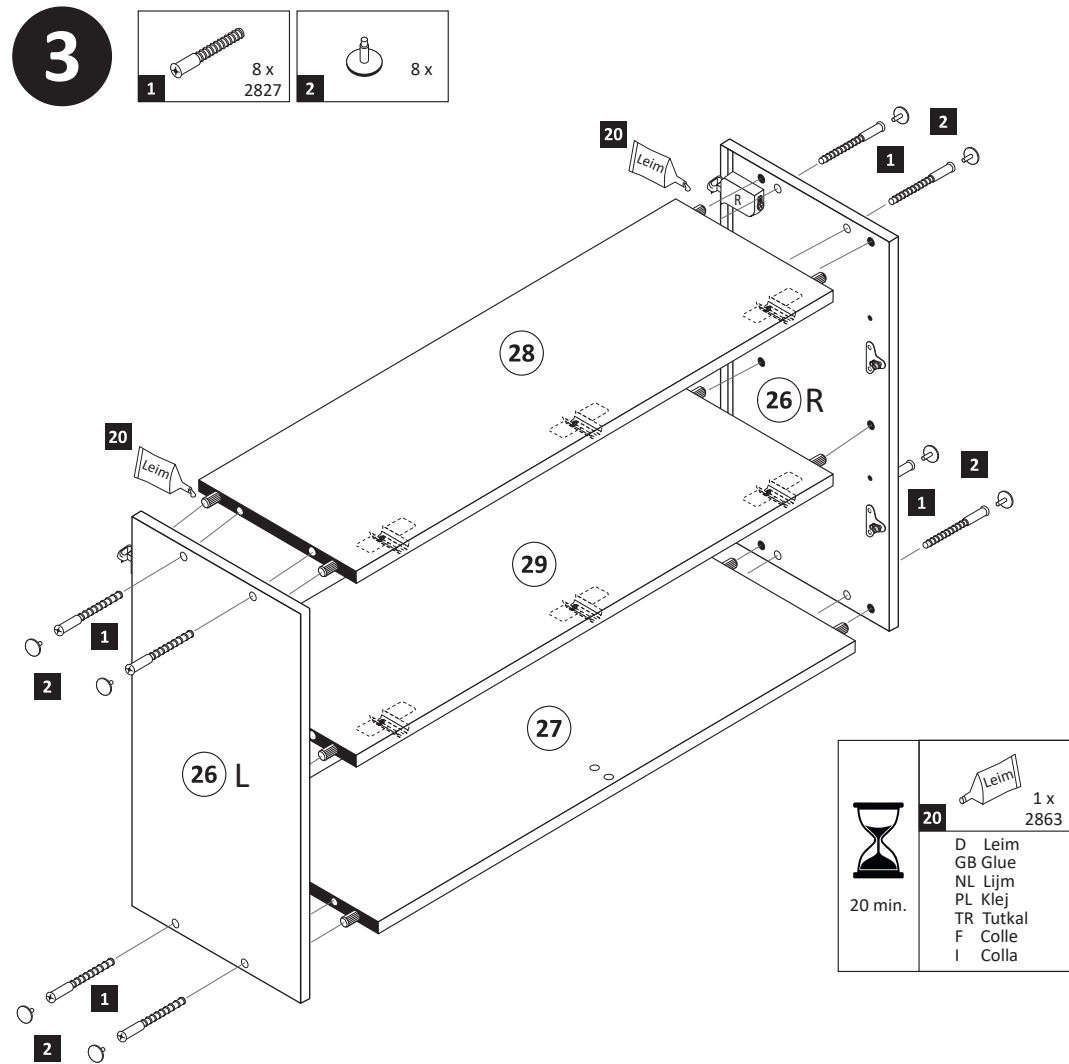

8

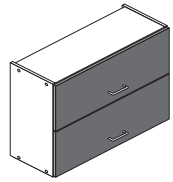

Achtung !
Für die Montageschritte **8** und **9** müssen Sie den Schrank auf den Kopf stellen.

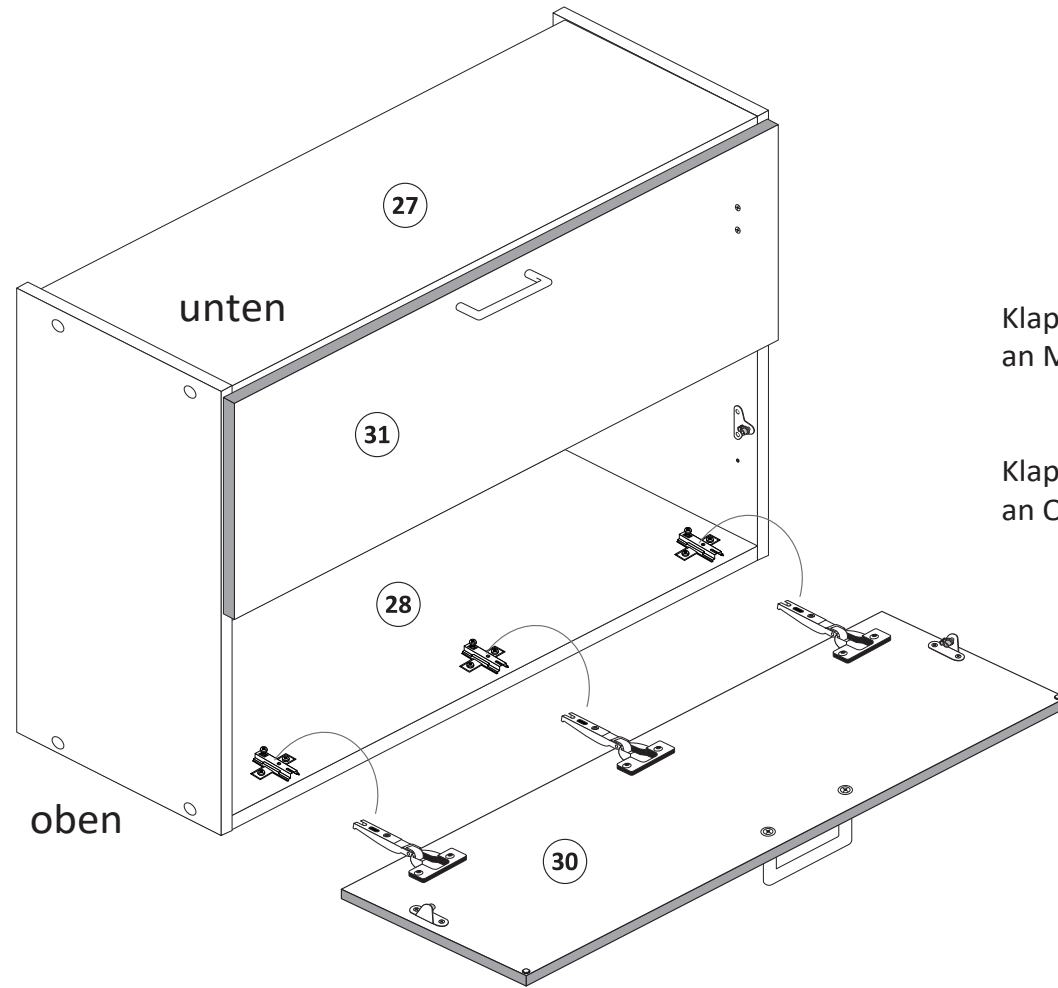

Klappe **31** mit Scharnieren **6** an Mittelboden **29** montieren !

Klappe **30** mit Scharnieren **4** an Oberboden **28** montieren !

10

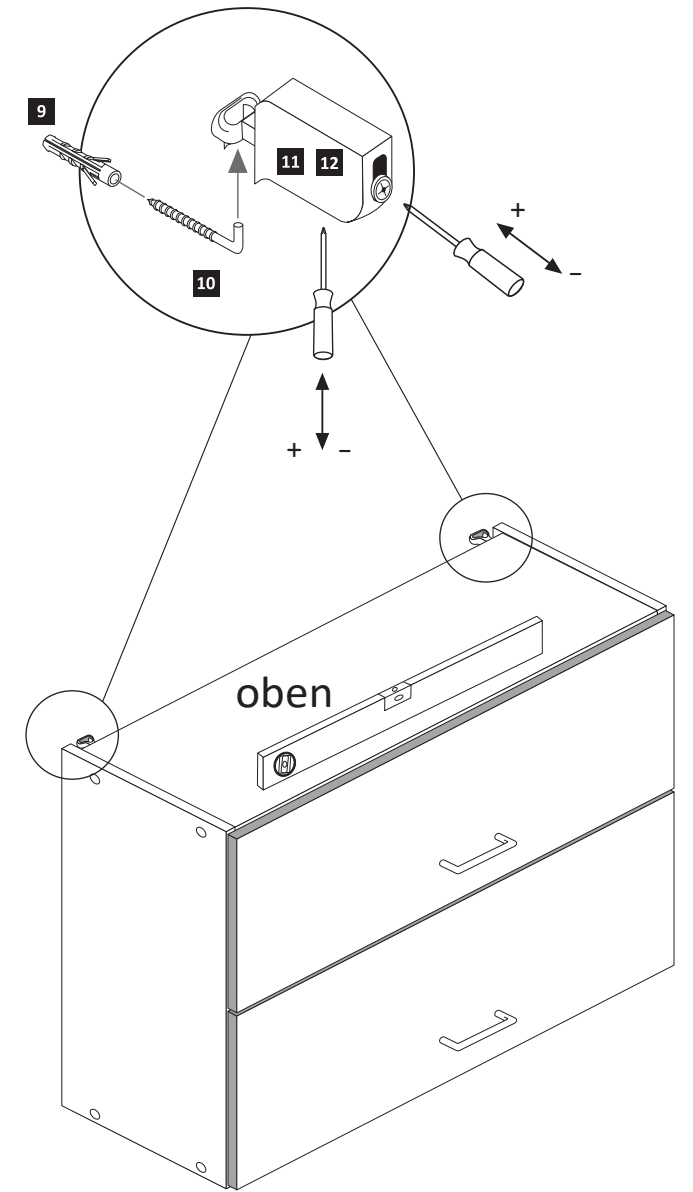
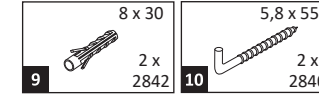

9

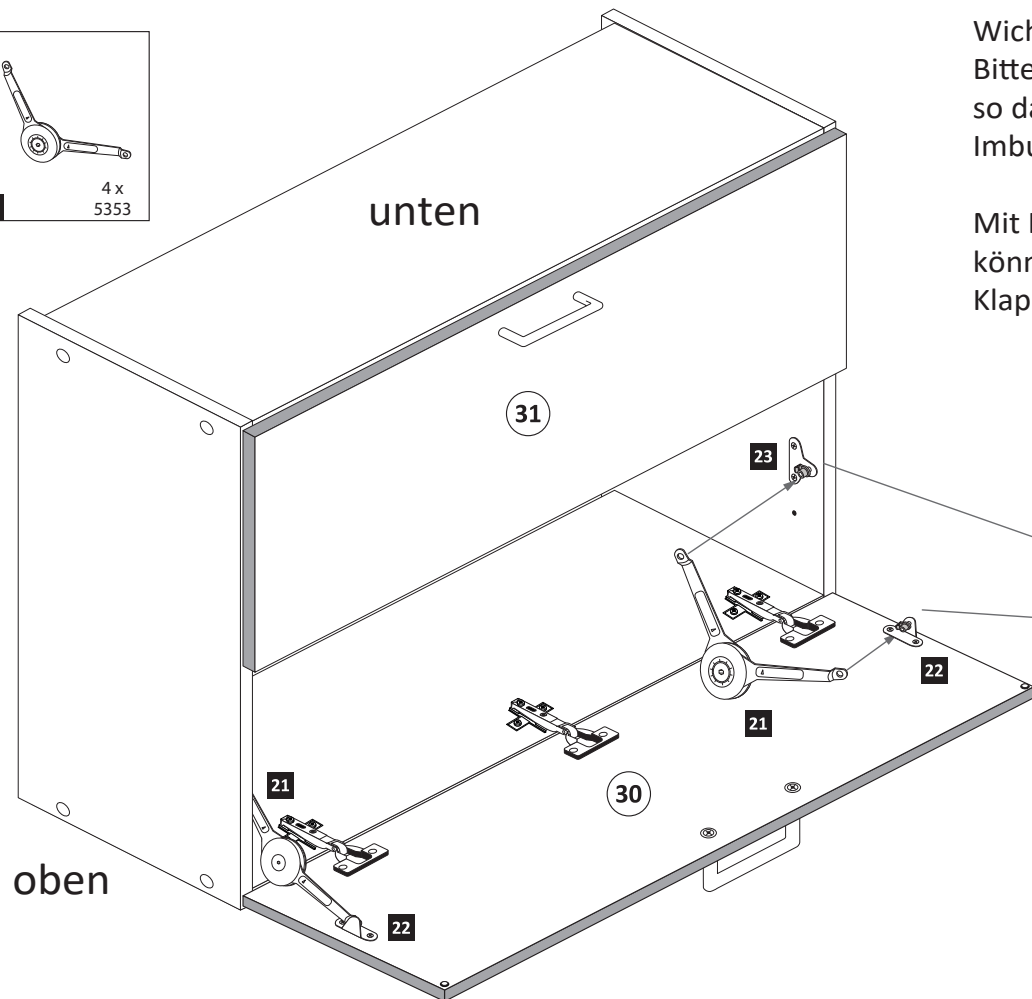
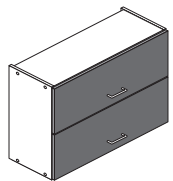
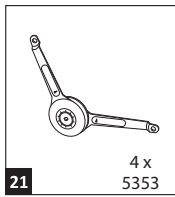

Wichtig!!
Bitte montieren Sie die Klappenhalter so dass die Aufnahme für den Imbusschlüssel zur Innenseite zeigt.

Mit Hilfe eines Imbusschlüssel können Sie den Widerstand der Klappenhalter regulieren.

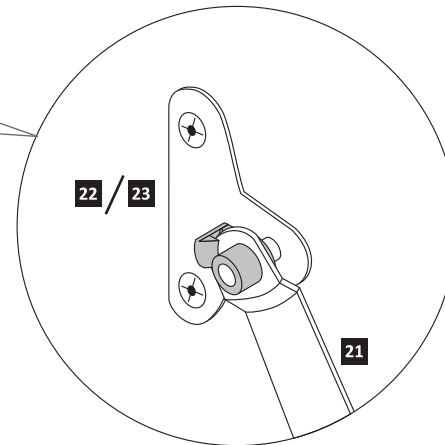
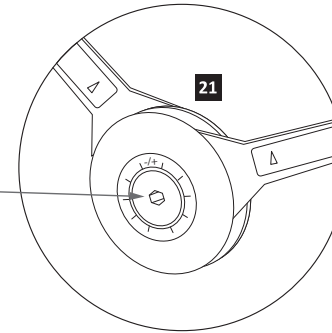

11

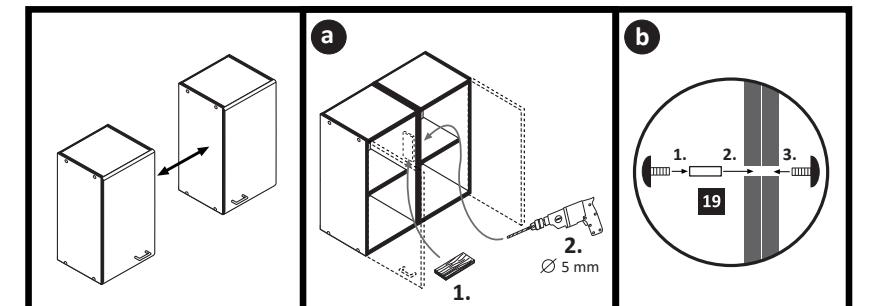
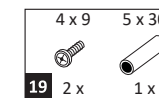



87267.310

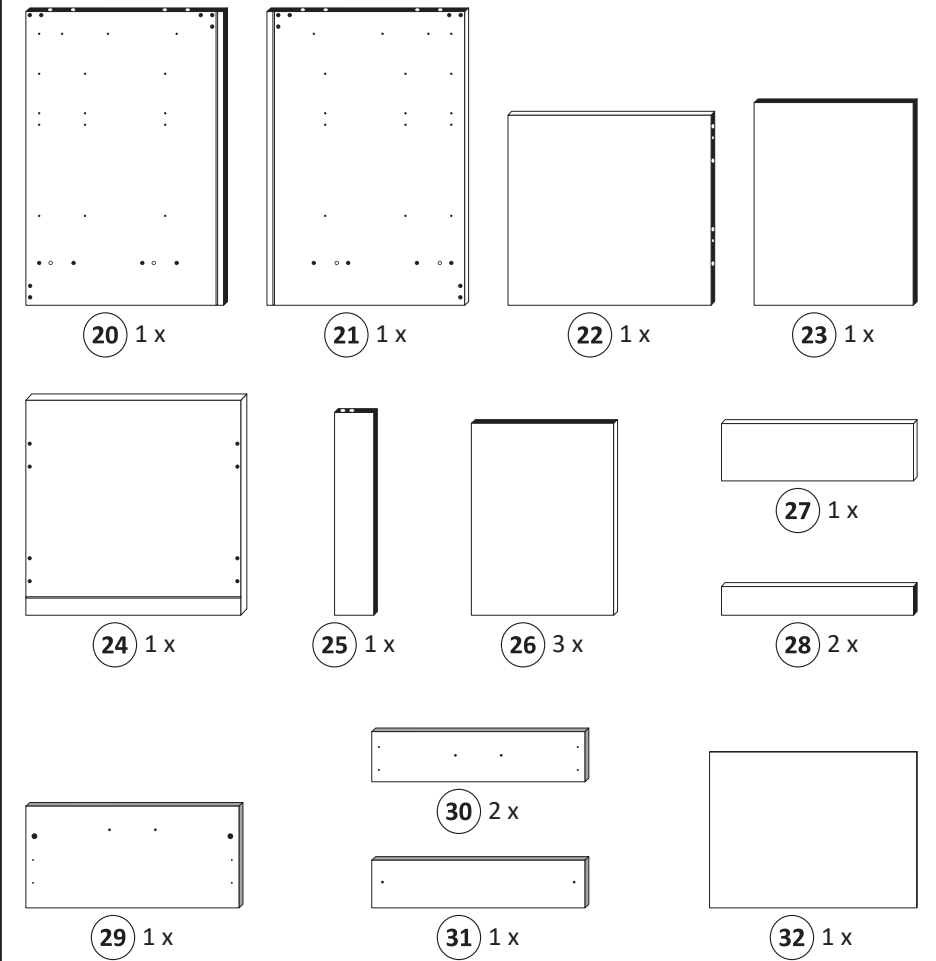
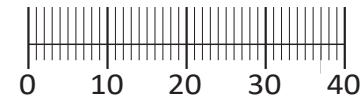
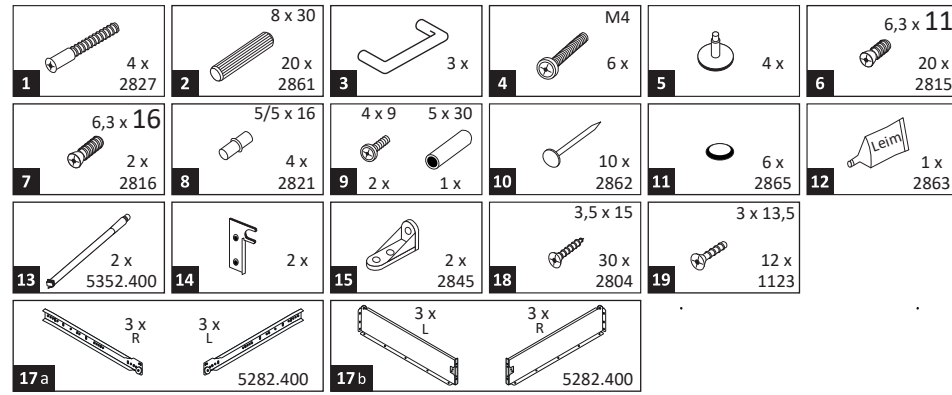
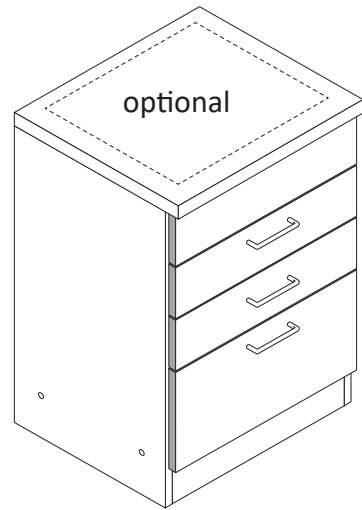
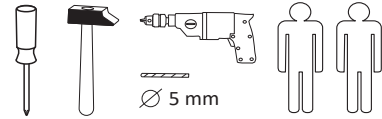

Das beigegefügte Wandbefestigungsmaterial (Dübel und Schrauben) eignet sich nur für festes Mauerwerk (z.B.: Beton- oder Ziegelwände). Für andere Wandaufbauten sind eventuell Spezialdübel und andere Schrauben notwendig. Ziehen Sie gegebenenfalls eine Fachkraft zu Rate.

De begeleidende wandmontage hardware (pluggen en schroeven) is alleen geschikt voor massief metselwerk (bijvoorbeeld beton of bakstenen muren). Voor andere muur structuren zijn eventueel bijzondere ankerbouten en andere noodzakelijke. Draai indien nodig, een deskundige.

Приложенный материал для крепления к стене (дюбели и винты) пригоден только для жестких кладок (например, бетонные или кирпичные стены). Для других настенных конструкций необходимы смотря по обстоятельствам специальные дюбели и другие винты. При необходимости проконсультируйтесь у специалиста.

Le mur d'accompagnement matériel de montage (chevilles et les vis) ne convient que pour la maçonnerie solide (par exemple en béton ou des murs de briques). Pour les structures de mur d'autres sont peut-être spéciale boulons d'ancrage et d'autres nécessaires. Serrer le cas échéant, un expert.

Załączony materiał do mocowania do ściany (kolki rozprężne i wkręty) nadaje się tylko do ścian murowanych (np. z betonu lub cegieł). Do ścian wykonanych w innych technologiach konieczne być mogą specjalne kolki rozprężne i inne wkręty. W razie potrzeby skorzystaj z fachowej pomocy

Il muro di accompagnamento hardware di montaggio (tasselli e viti) è adatto solo per muratura piena (ad esempio calcestruzzo o muratura). Per le altre strutture murarie sono forse speciali bulloni di ancoraggio e necessari di altri. Serrare se necessario, un esperto.

The accompanying wall mounting hardware (anchors and screws) is suitable only for solid masonry (eg concrete or brick walls). For other wall structures are possibly special anchor bolts and other necessary. Tighten if necessary, an expert.

Ekteki duvara sabit montaj malzemeleri (dübel ve vidalar), sadece sağlam duvarlar için (örnek: beton veya tuğla) elverişlidir. Başka duvarlar için özel dübeller ve farklı vidalar gerekebilir. Gerektiğinde bir uzmana danışınız.

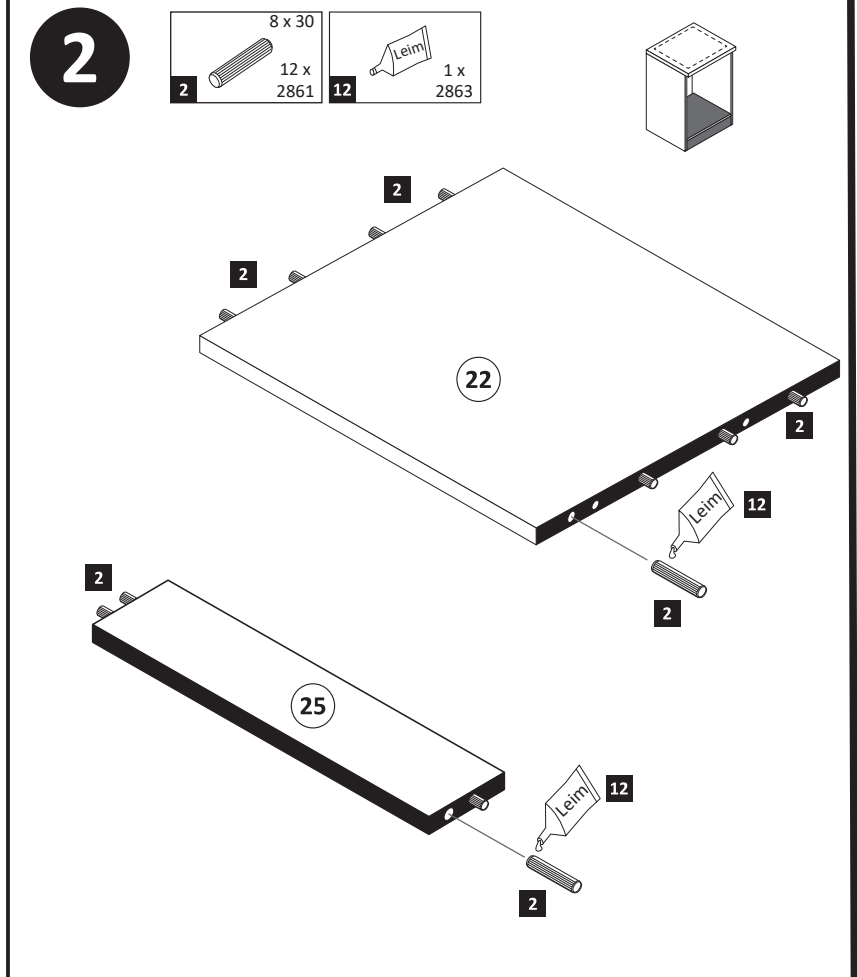
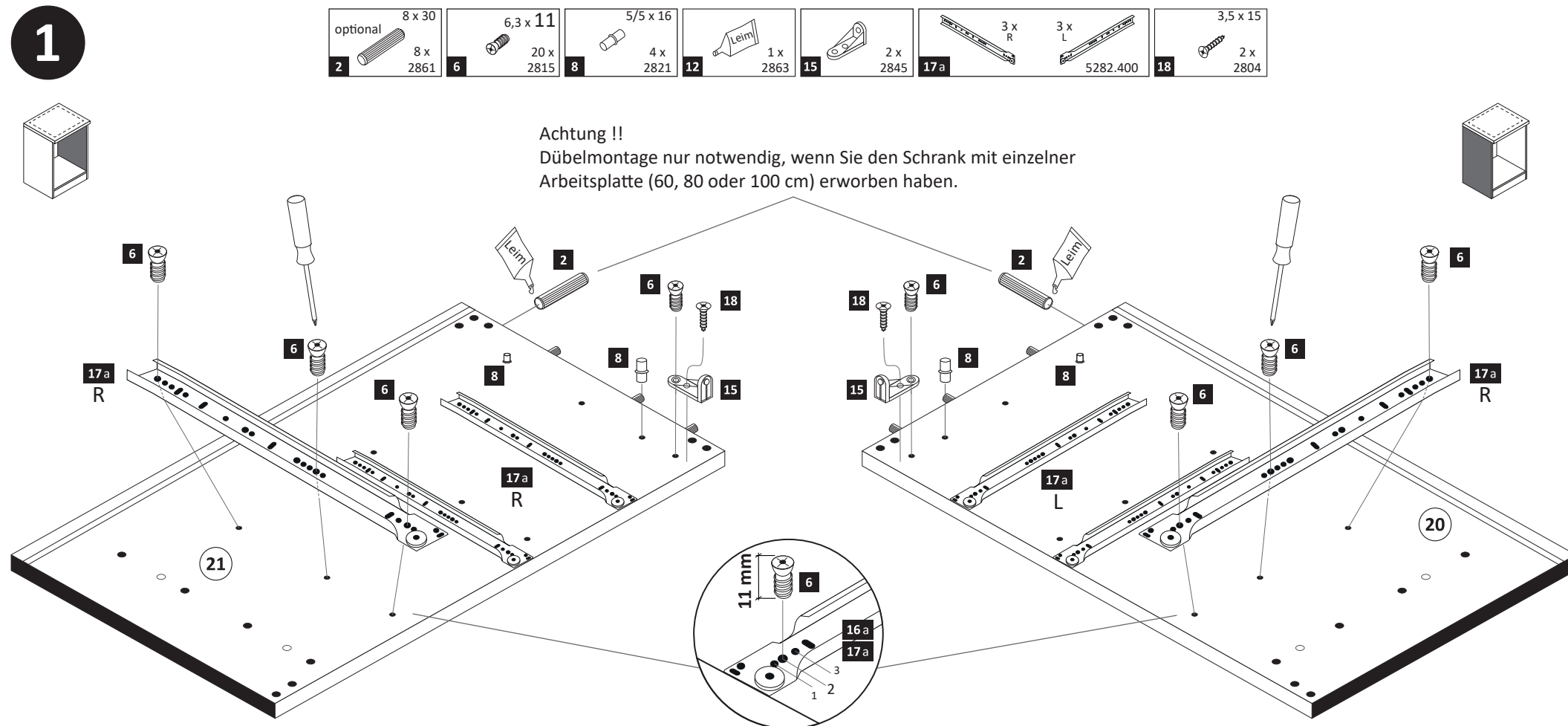

- 3**
- 1 4 x 2827
 - 5 4 x
 - 7 6,3 x 16 2 x 2816

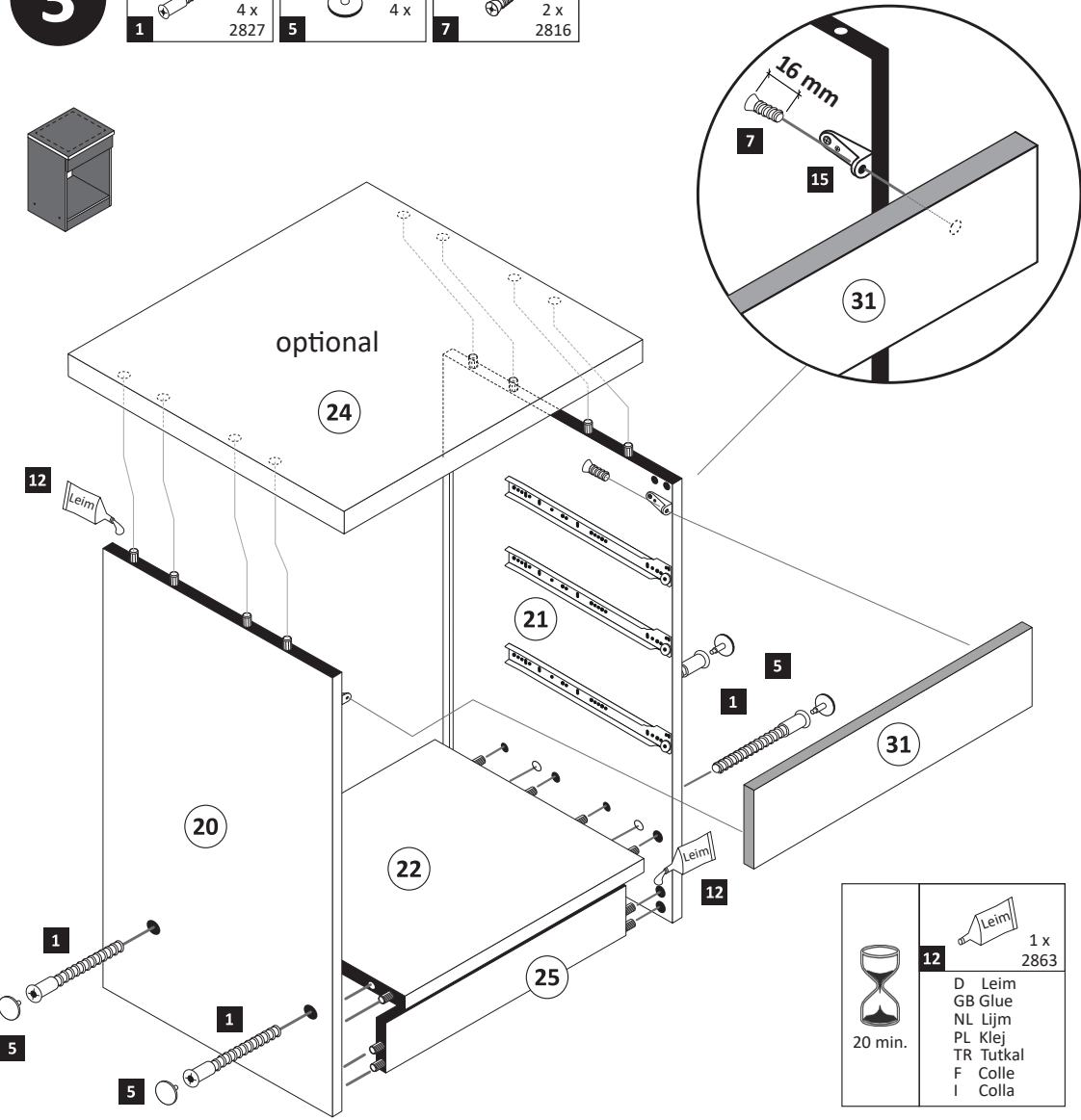

- 5**

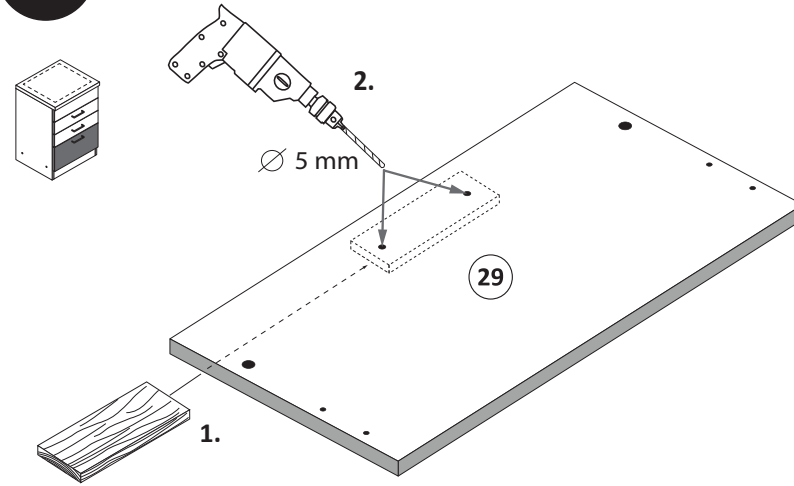

- 8**

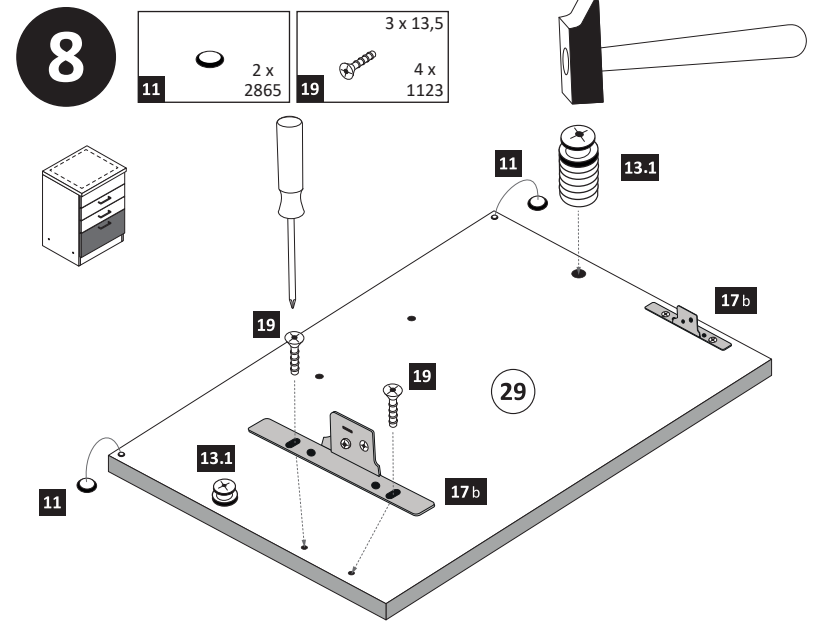

- 6**

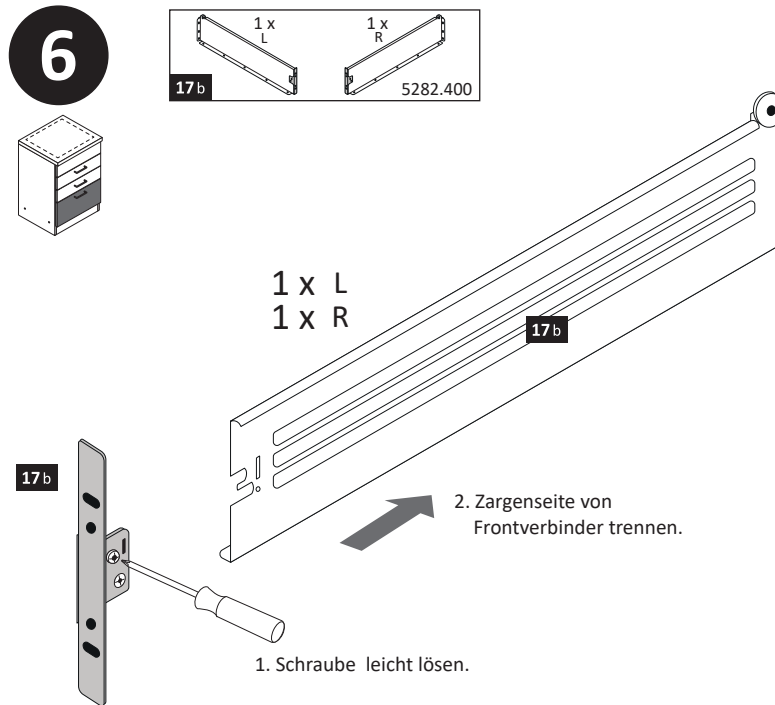

- 9**

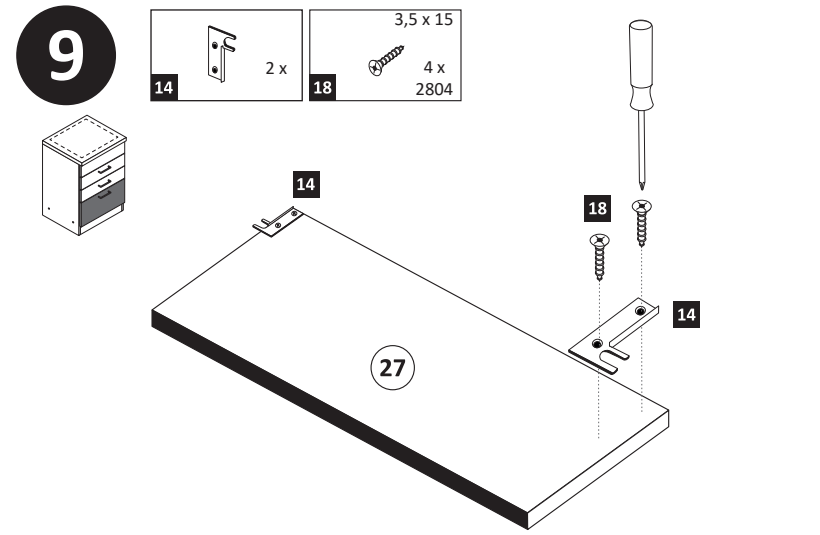

- 4**

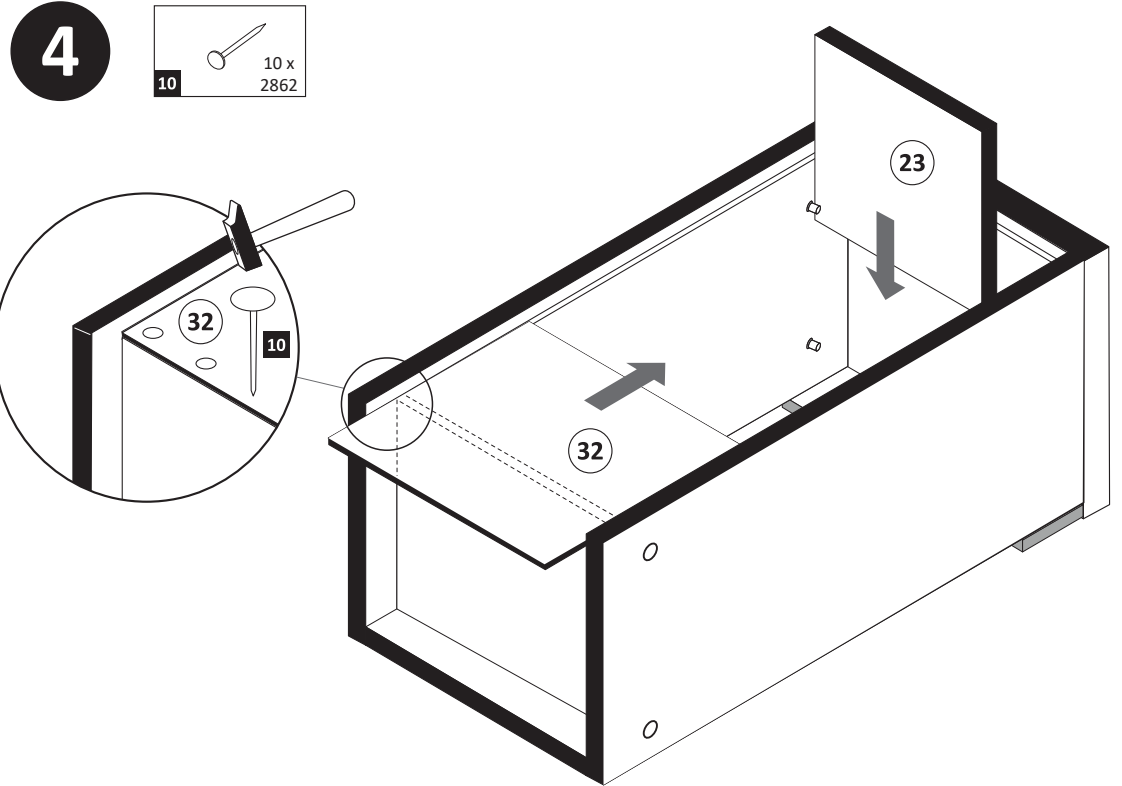

- 10**

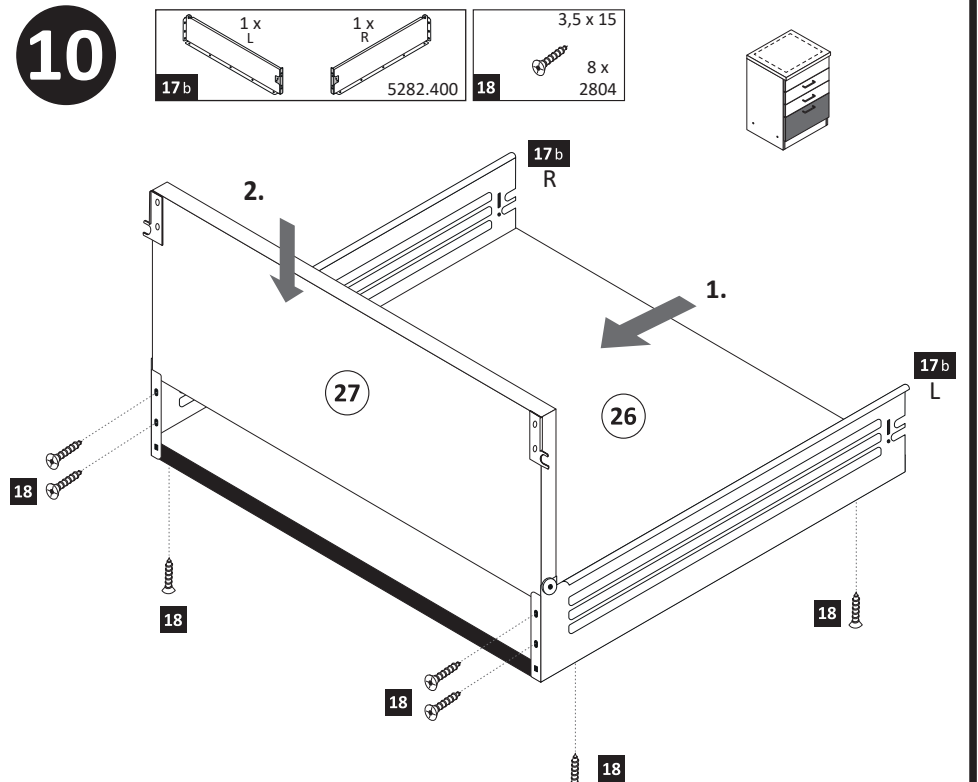

- 7**

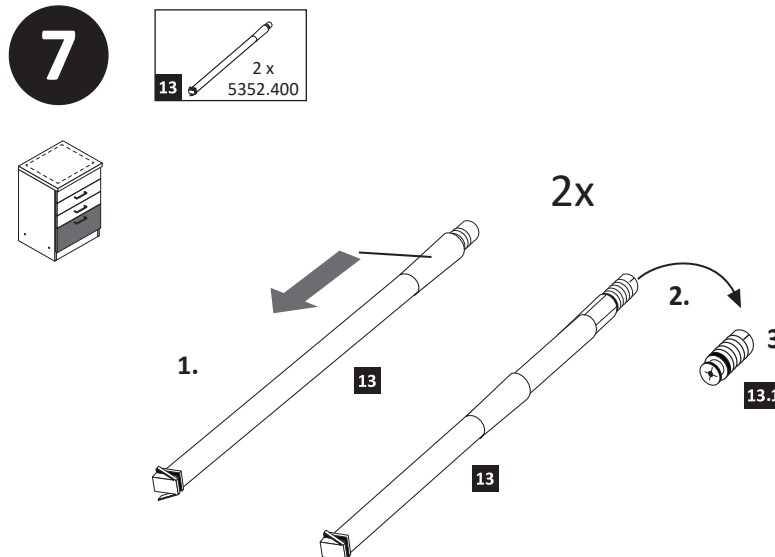

11

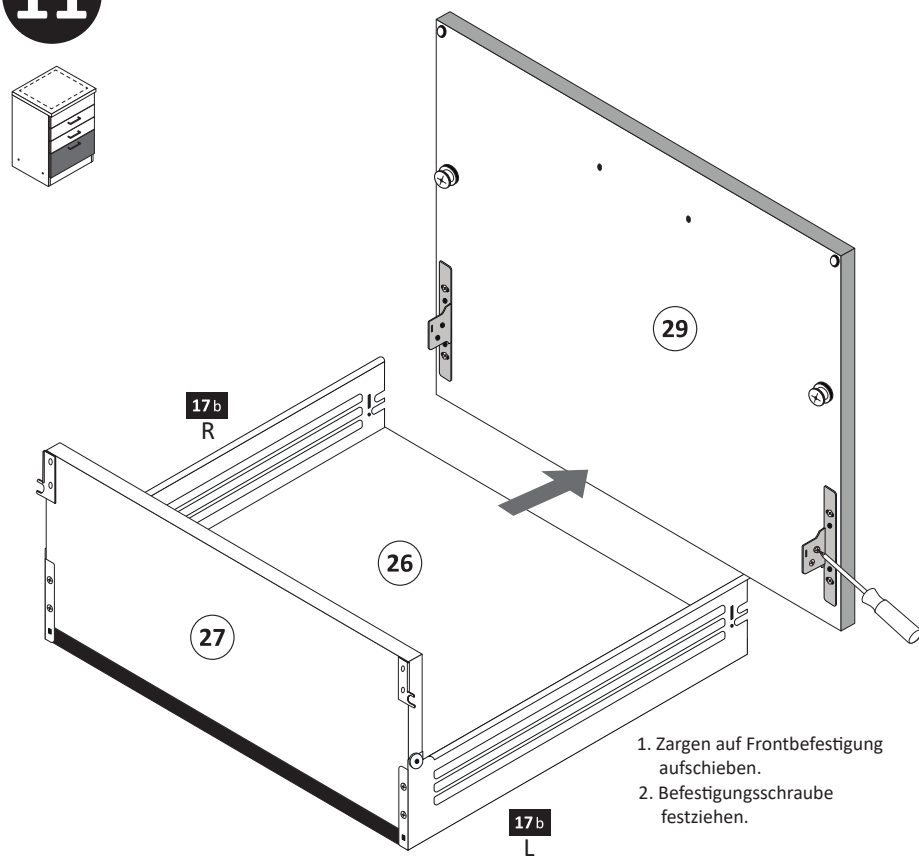

13

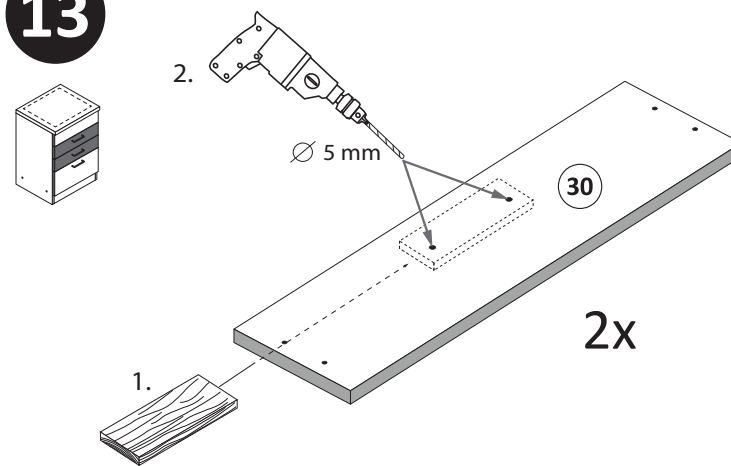

14

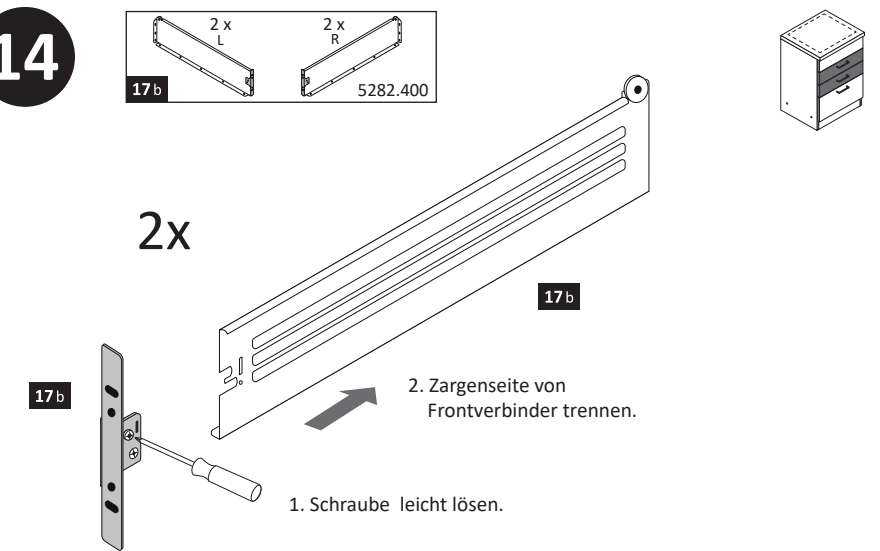

12

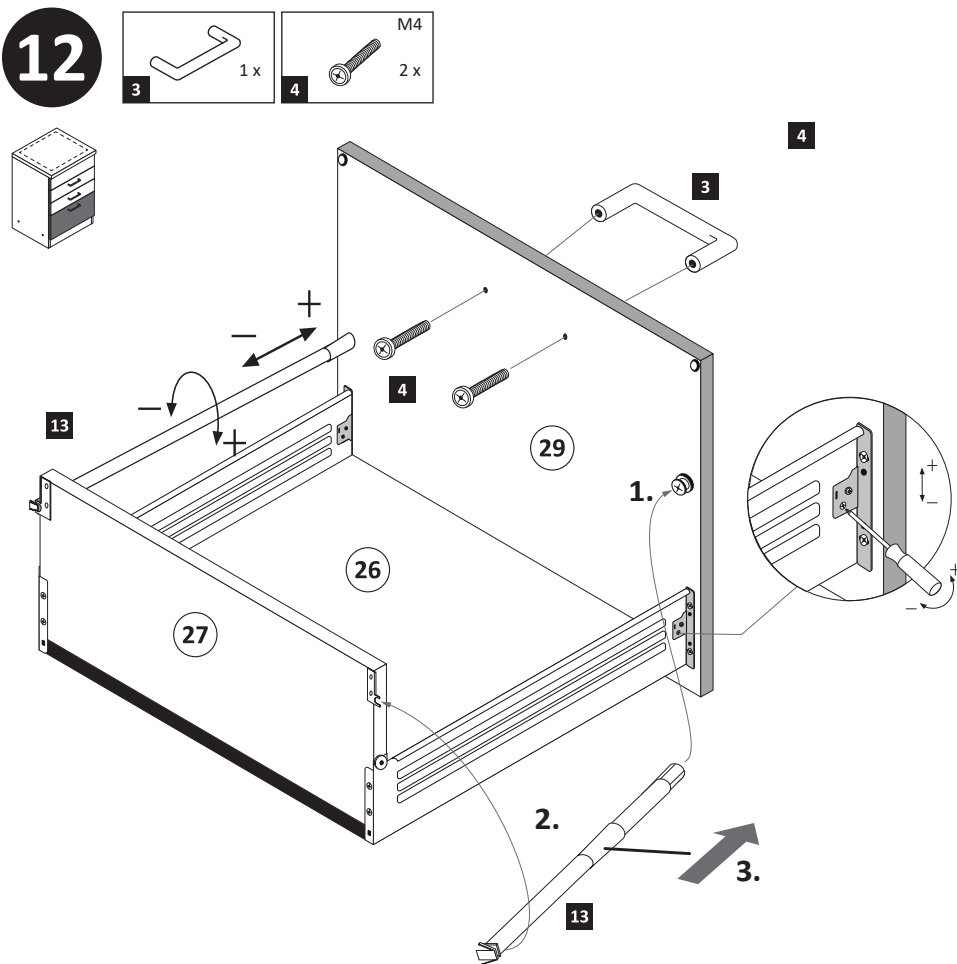

15

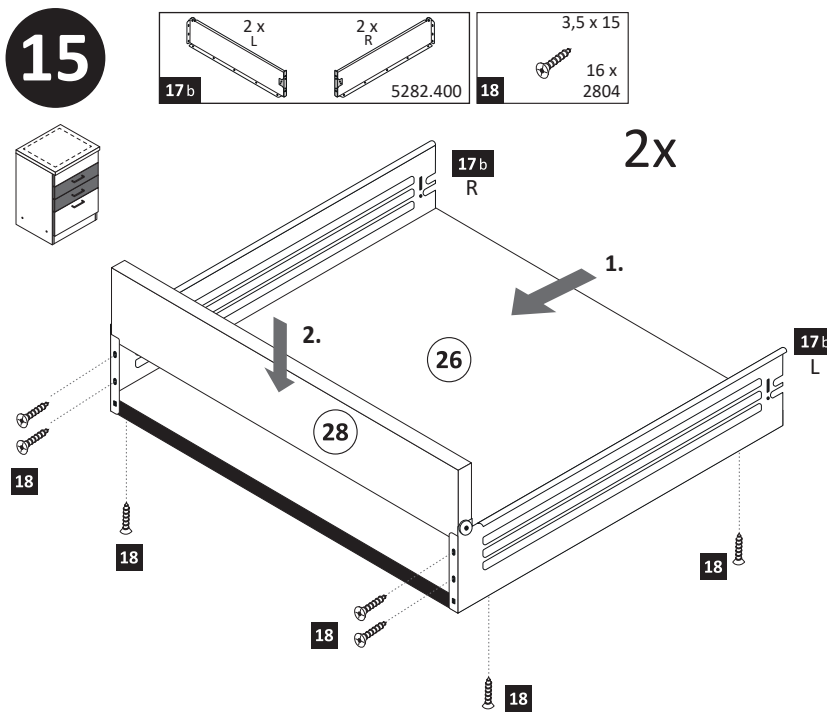

16

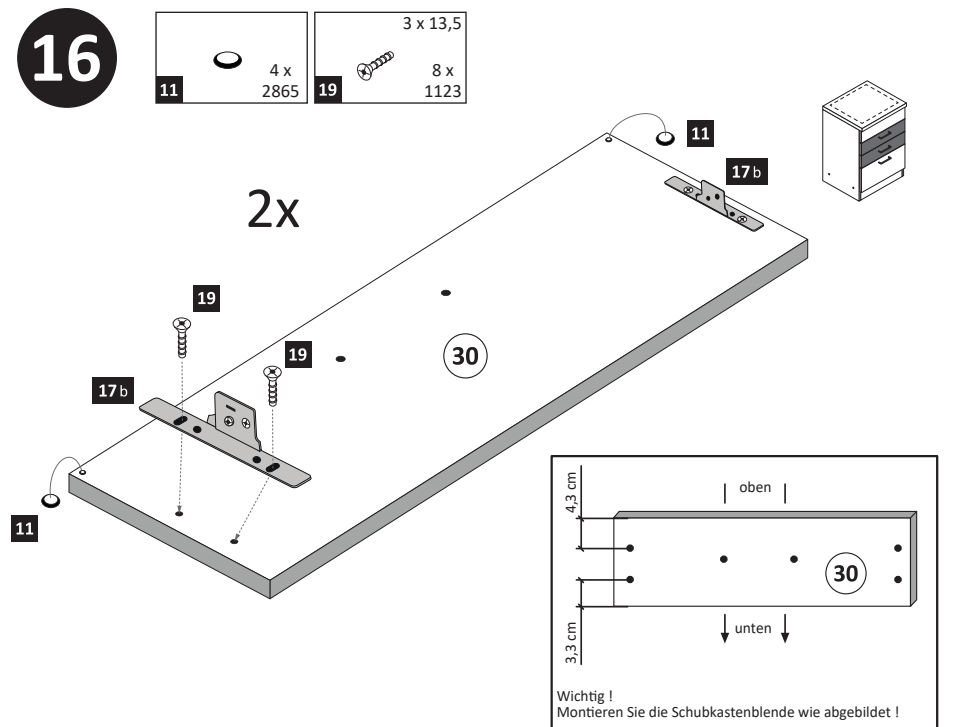

17

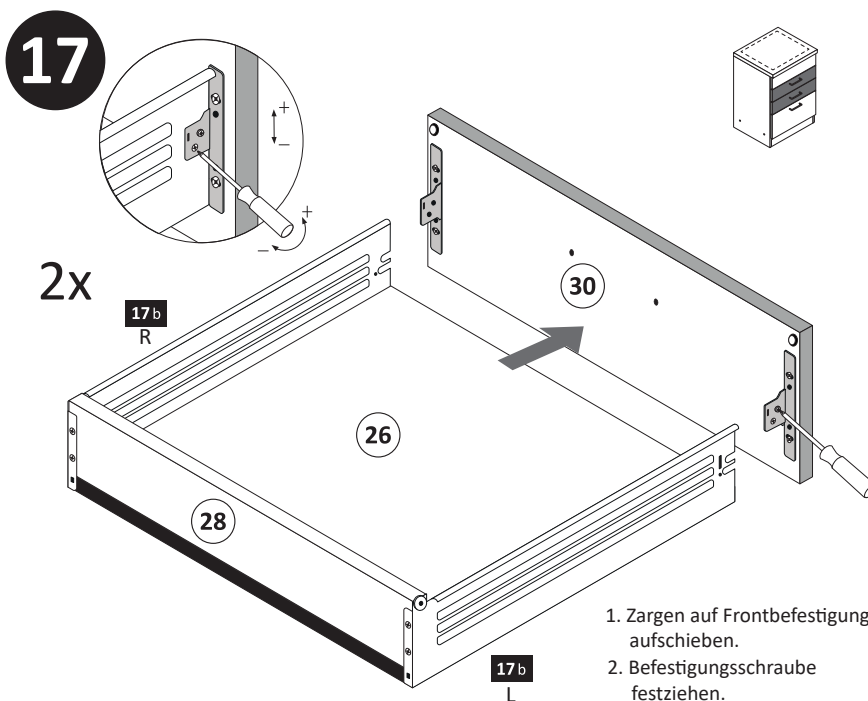

18

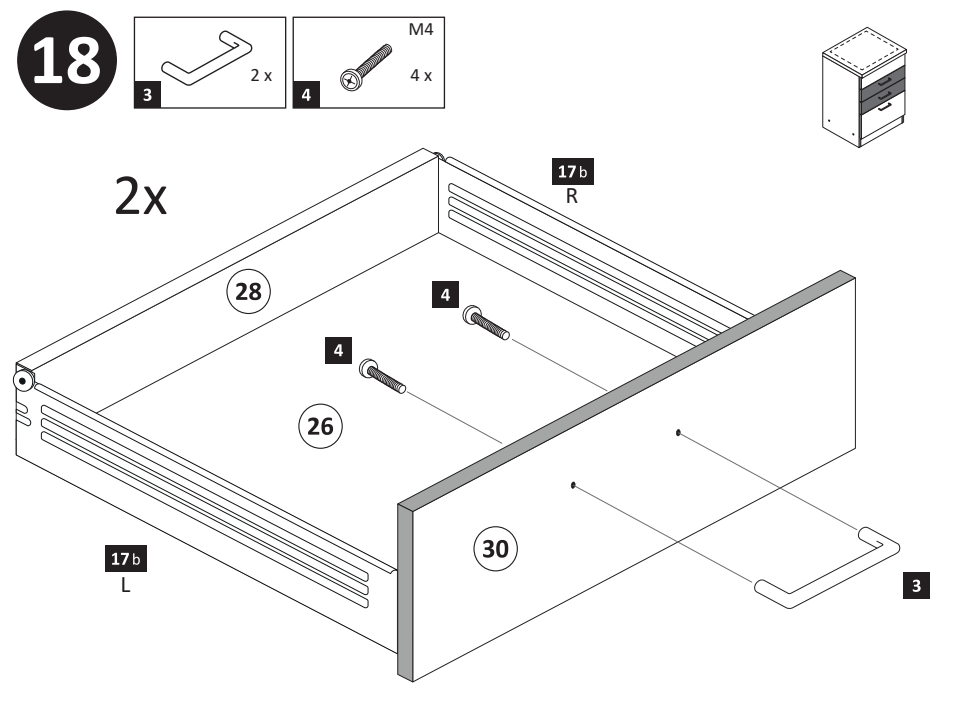

19

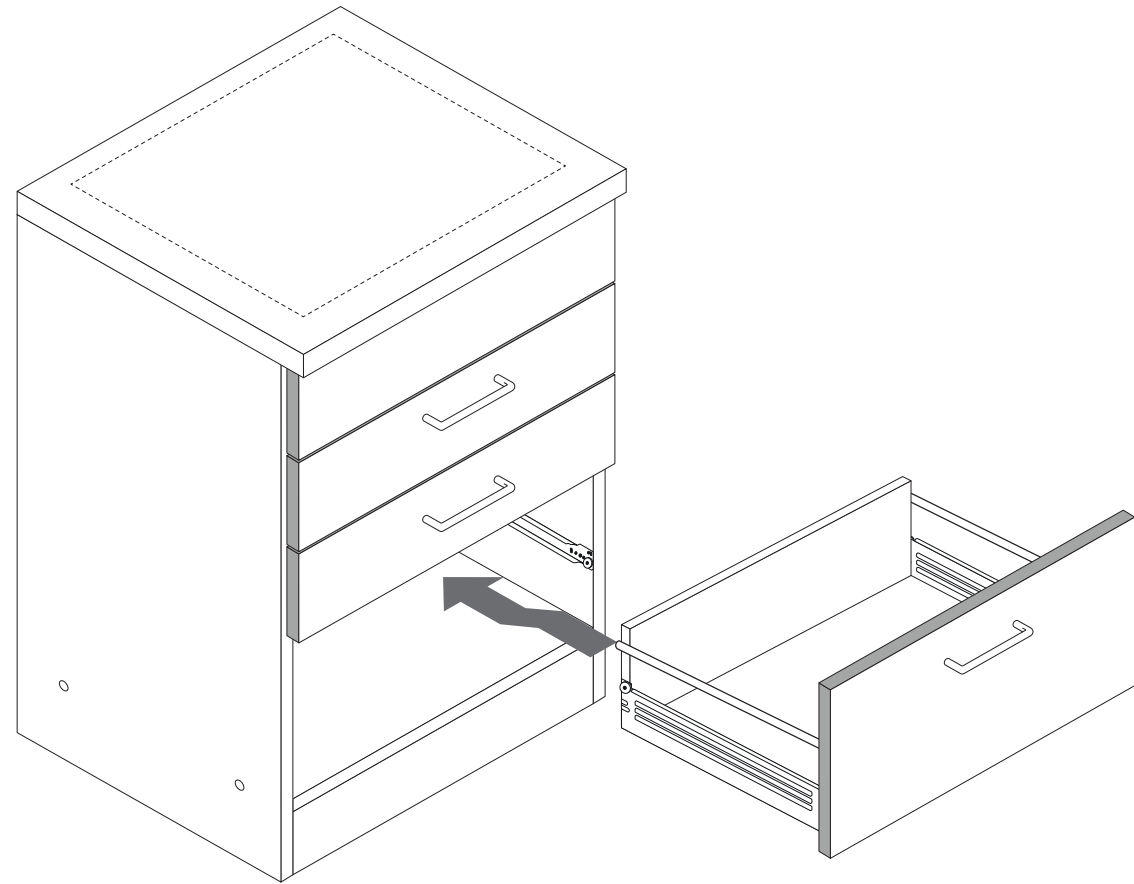
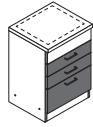

20

optional

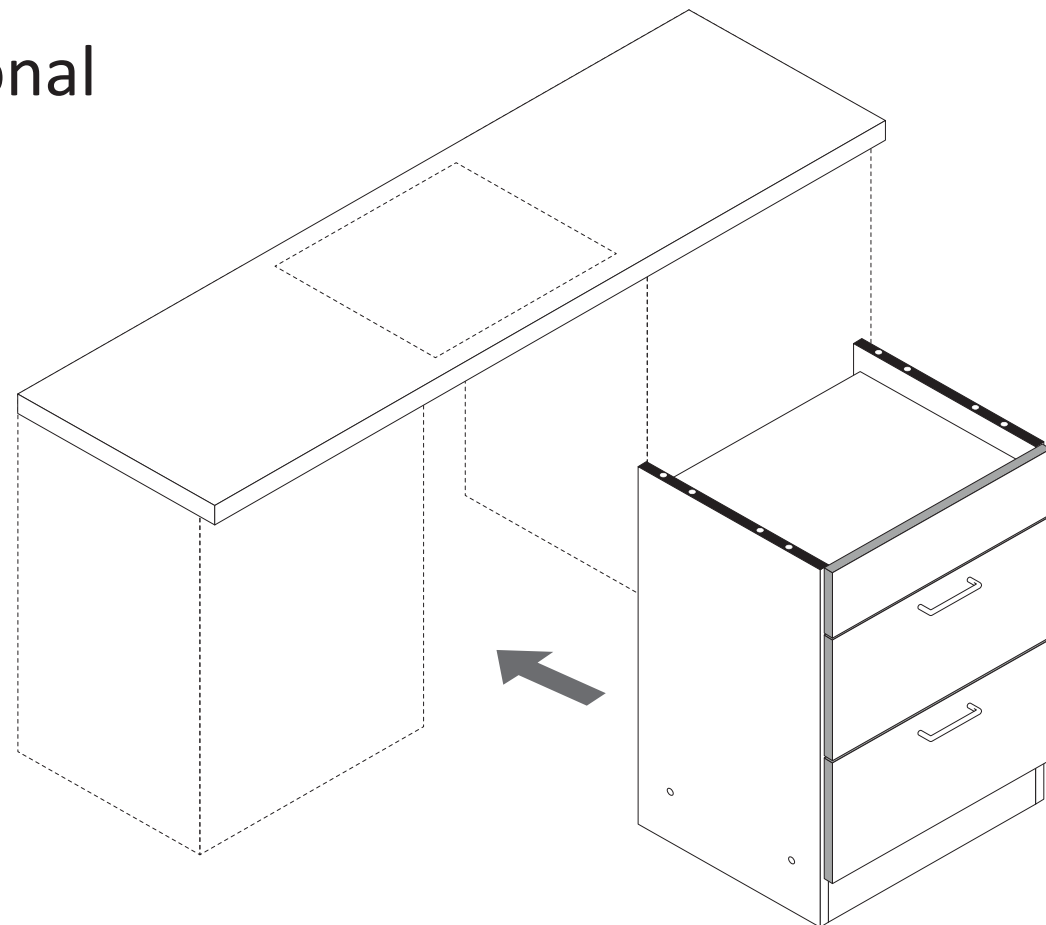

21

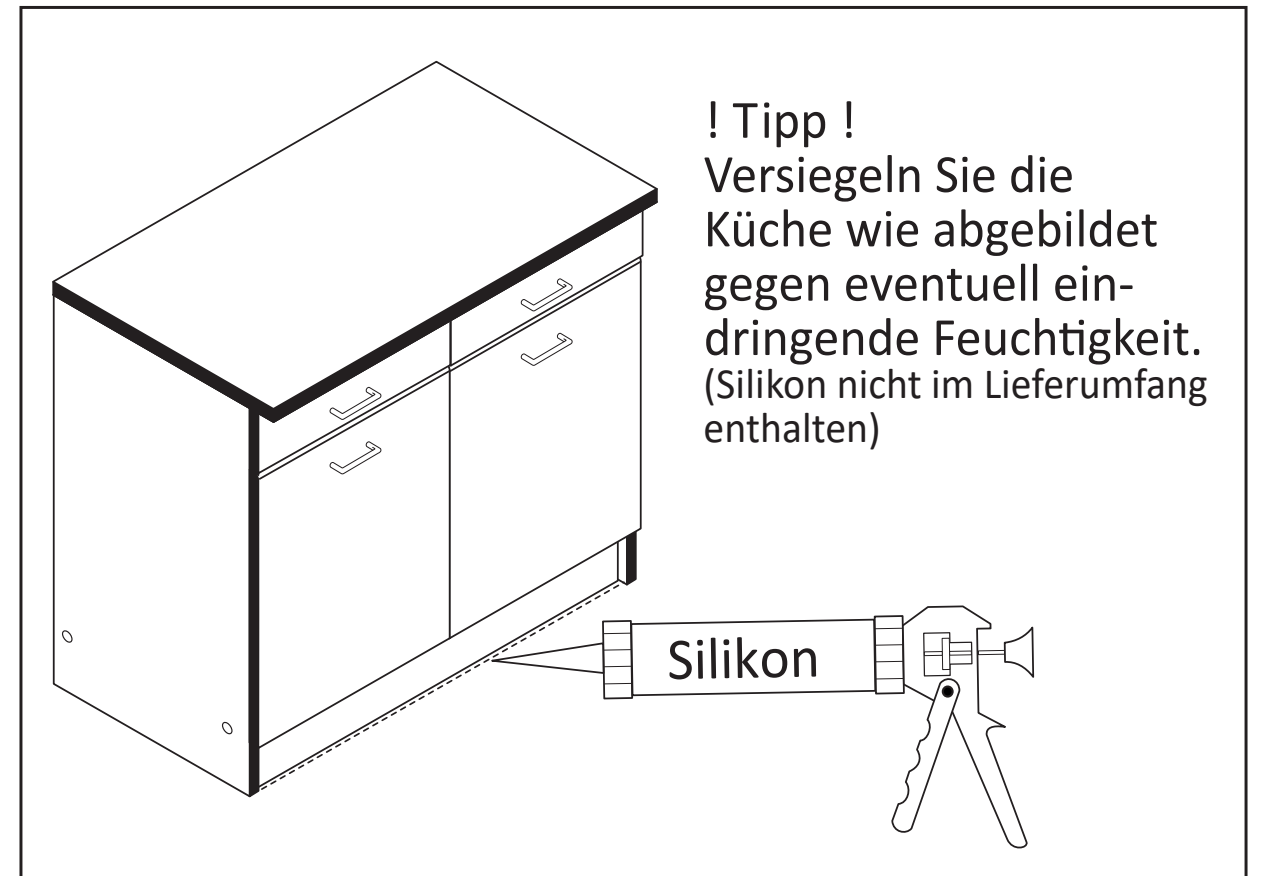
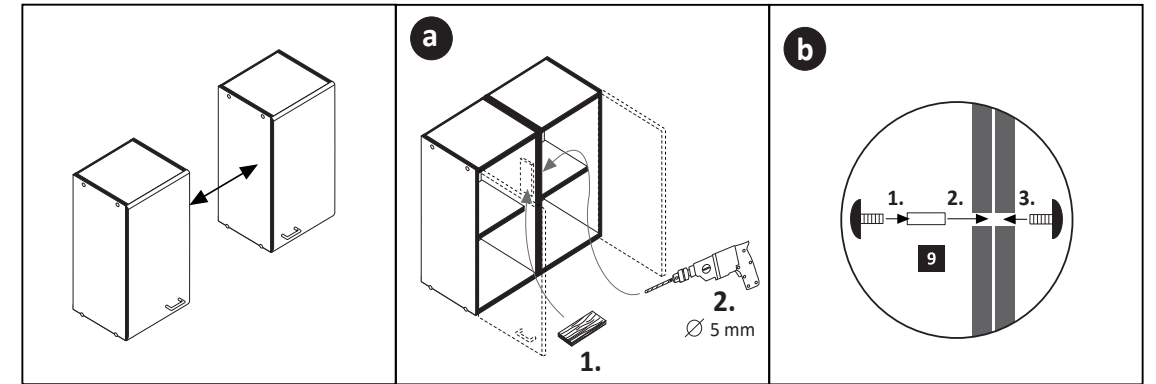
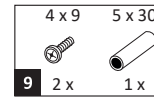



87253.530

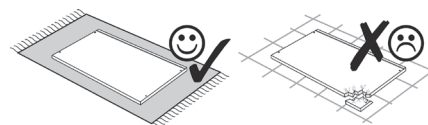
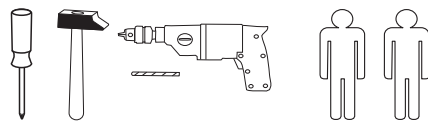
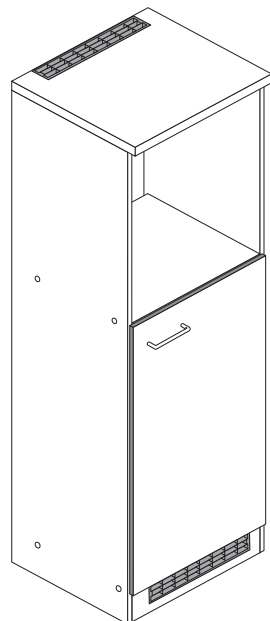

1 8 x 2827	2 8 x	3 8 x 30 28 x 2861	5 2 x 1503	6 2 x 1611
7 3,5 x 15 6 x 2804	8 1 x	9 2 x	10 5mm 2 x 2855	11 2 x 2865
12 2 x 2845	13 4 x 15 2 x 2810	14 4 x 45 2 x 2814	15 6 x 34 2 x 2844	16 2 x 4 x 9 5 x 30 1 x
17 2 x 2532	18 2 x 2533	19 2 x 4530	20 1 x 2863	

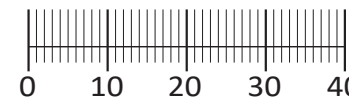

Das beigefügte Wandbefestigungsmaterial (Dübel und Schrauben) eignet sich nur für festes Mauerwerk (z.B.: Beton- oder Ziegelwände). Für andere Wandaufbauten sind eventuell Spezialdübel und andere Schrauben notwendig. Ziehen Sie gegebenenfalls eine Fachkraft zu Rate.

De begeleidende wandmontage hardware (pluggen en schroeven) is alleen geschikt voor massief metselwerk (bijvoorbeeld beton of bakstenen muren). Voor andere muur structuren zijn eventueel bijzondere ankerbouten en andere noodzakelijke. Draai indien nodig, een deskundige.

Приложенный материал для крепления к стене (дюбели и винты) пригоден только для жестких кладок (например, бетонные или кирпичные стены). Для других настенных конструкций необходимы смотря по обстоятельствам специальные дюбели и другие винты. При необходимости проконсультируйтесь у специалиста.

Le mur d'accompagnement matériel de montage (chevilles et les vis) ne convient que pour la maçonnerie solide (par exemple en béton ou des murs de briques). Pour les structures de mur d'autres sont peut-être spéciale boulons d'ancrage et d'autres nécessaires. Serrer le cas échéant, un expert.

Załączony materiał do mocowania do ściany (kolki rozprężne i wkręty) nadaje się tylko do ścian murowanych (np. z betonu lub cegiel). Do ścian wykonanych w innych technologiach konieczne być mogą specjalne kolki rozprężne i inne wkręty. W razie potrzeby skorzystaj z fachowej pomocy

Il muro di accompagnamento hardware di montaggio (tasselli e viti) è'e adatto solo per muratura piena (ad esempio calcestruzzo o muratura). Per le altre strutture murarie sono forse speciali bulloni di ancoraggio e necessari di altri. Serrare se necessario, un esperto.

The accompanying wall mounting hardware (anchors and screws) is suitable only for solid masonry (eg concrete or brick walls). For other wall structures are possibly special anchor bolts and other necessary. Tighten if necessary, an expert.

Ekteki duvara sabit montaj malzemeleri (dübel ve vidalar), sadece sağlam duvarlar için (örnek: beton veya tuğla) elverişlidir. Başka duvarlar için özel dübeller ve farklı vidalar gerekebilir. Gerekliğinde bir uzmana danışınız.

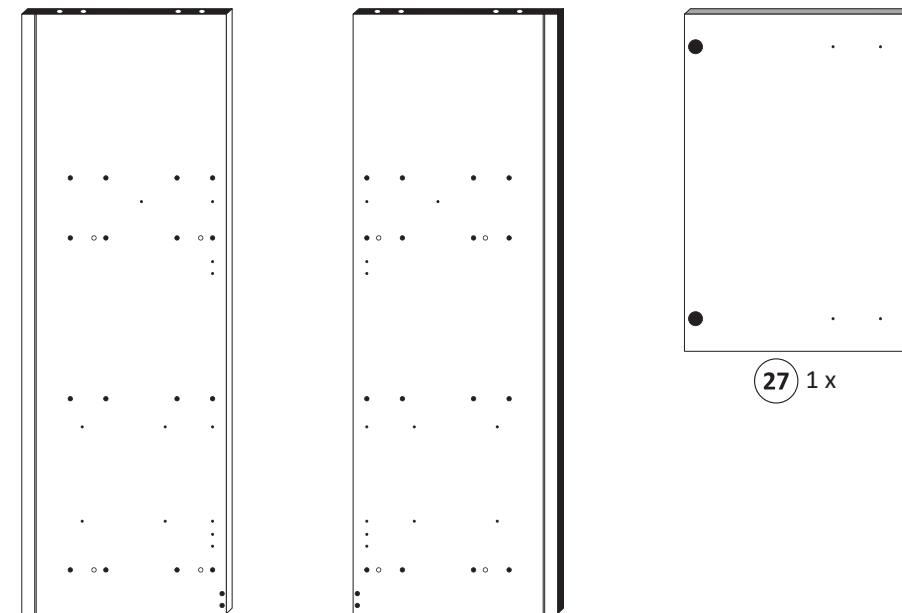

27 1 x

25 1 x

26 1 x

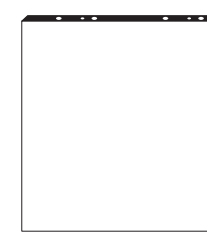

28 2 x



29 1 x

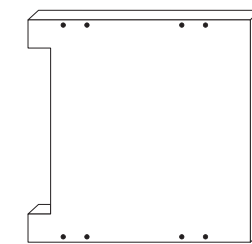

30 1 x

1

3 8 x 30 8 x 2861	6 2 x 1611	20 1 x 2863
-----------------------------------	-------------------------	--------------------------

Bitte beachten !

In dieser Aufbauanleitung ist die Tür rechts angeschlagen. Soll die Tür links angeschlagen werden, müssen die Kreuzmontageplatten **6** auf das linke Seitenteil **26** montiert werden.

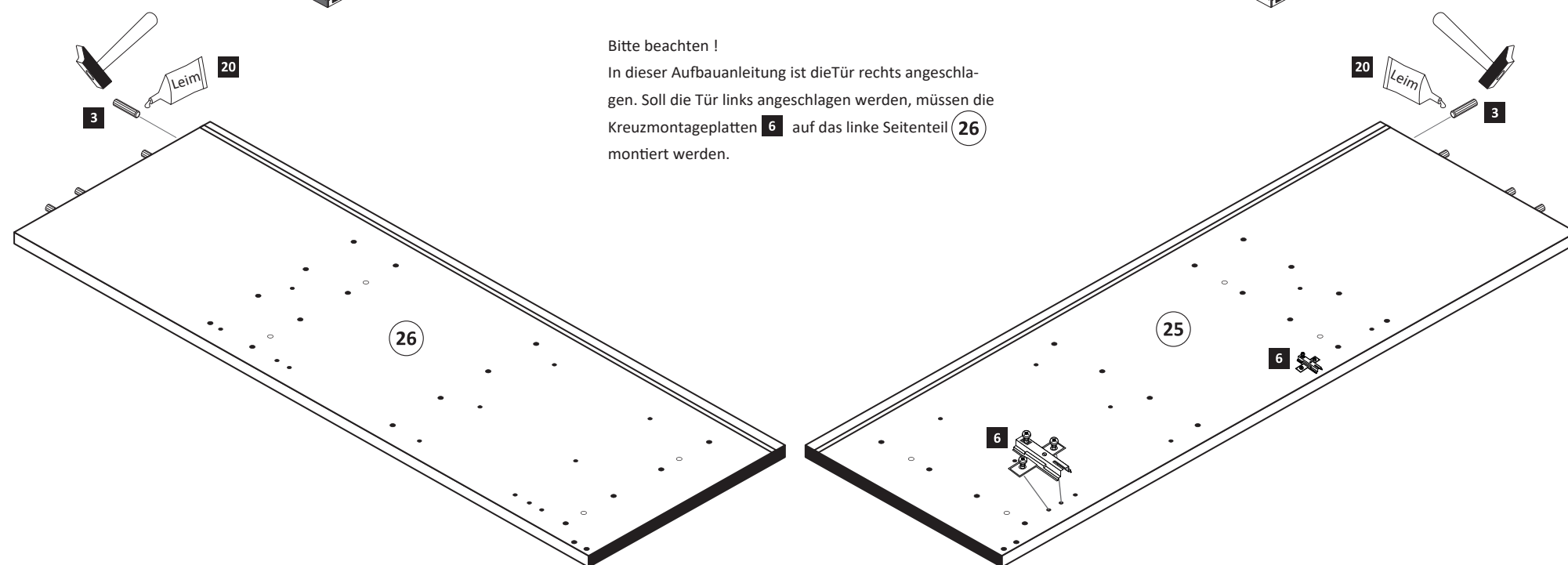

2

3 8 x 30 20 x 2861	17 2 x 2532	19 1 x 4530	20 1 x 2863
------------------------------------	--------------------------	--------------------------	--------------------------

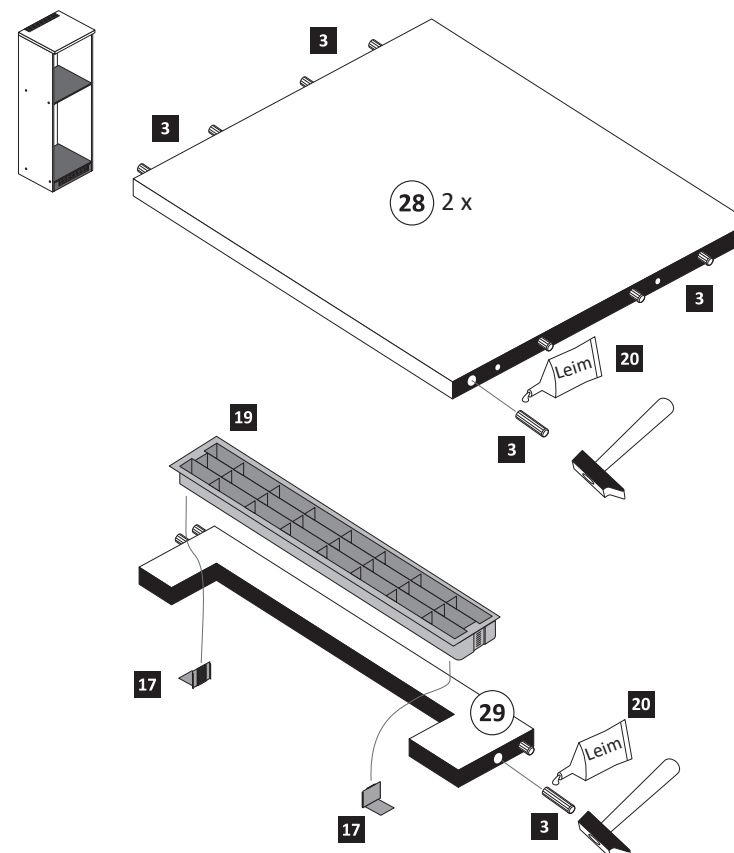

3

- 1 8 x 2827
- 2 8 x
- 18 2 x 2533
- 19 2 x 4530

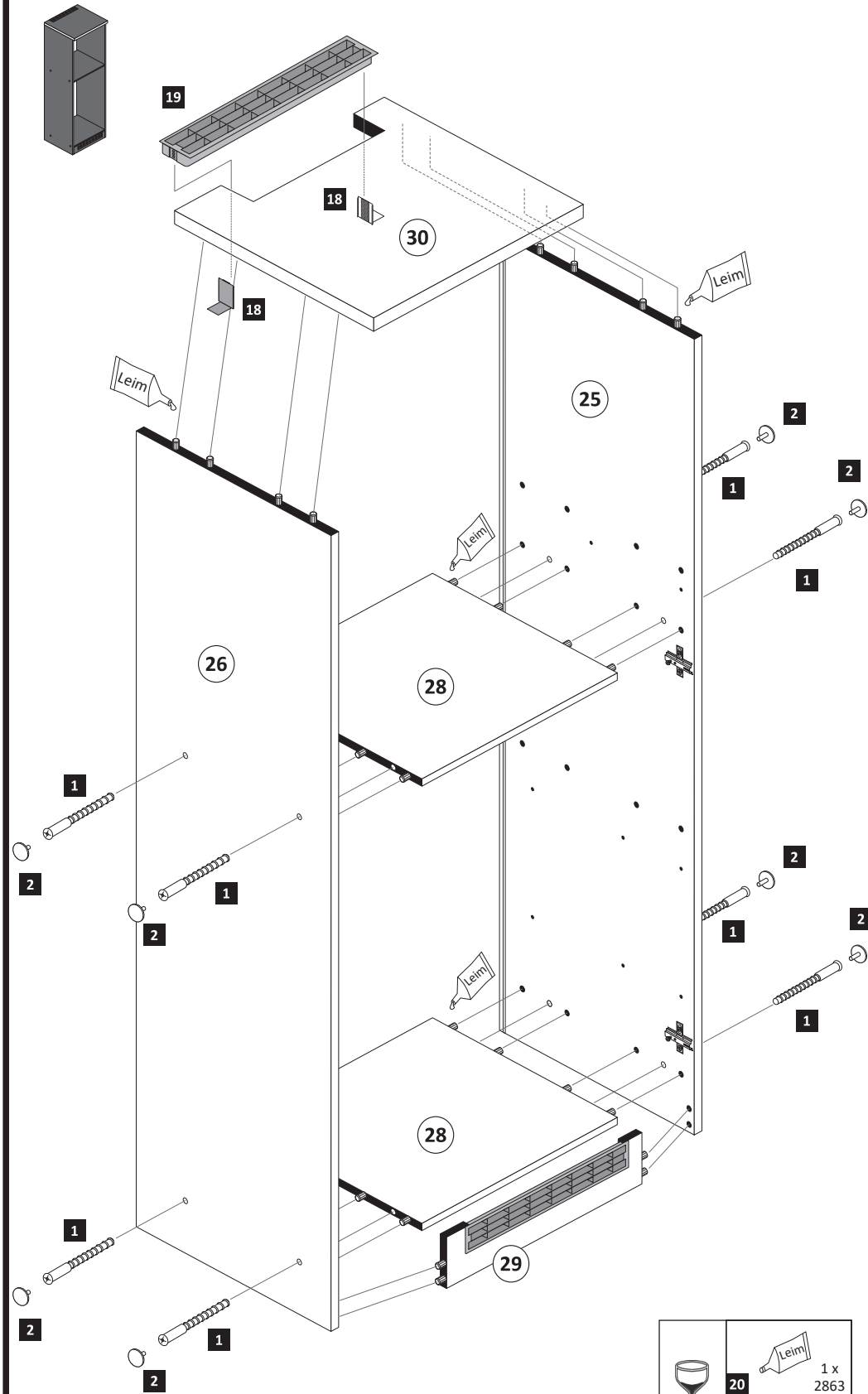

20 1 x 2863
 D Leim
 GB Glue
 NL Lijm
 PL Klej
 TR Tutkal
 F Colle
 I Colla

20 min.

4

- 5 2 x 1503
- 7 3,5 x 15 4 x 2804
- 11 4 x 2865

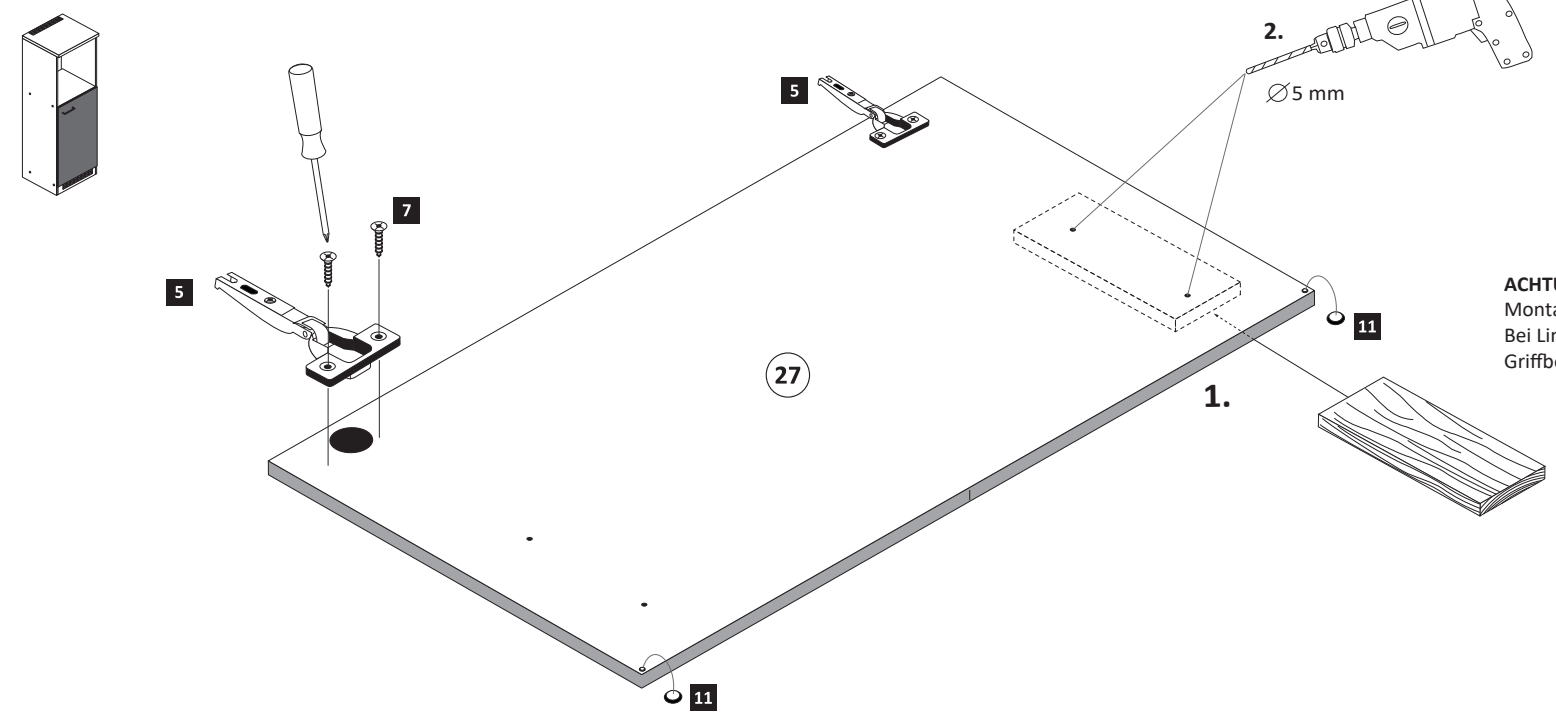

ACHTUNG!
 Montagebeispiel Rechtsanschlag
 Bei Linksanschlag andere
 Griffbohrungen durch bohren!

5

- 8 1 x
- 9 M4 x 22 2 x 2836
- 10 5mm 2 x 2855

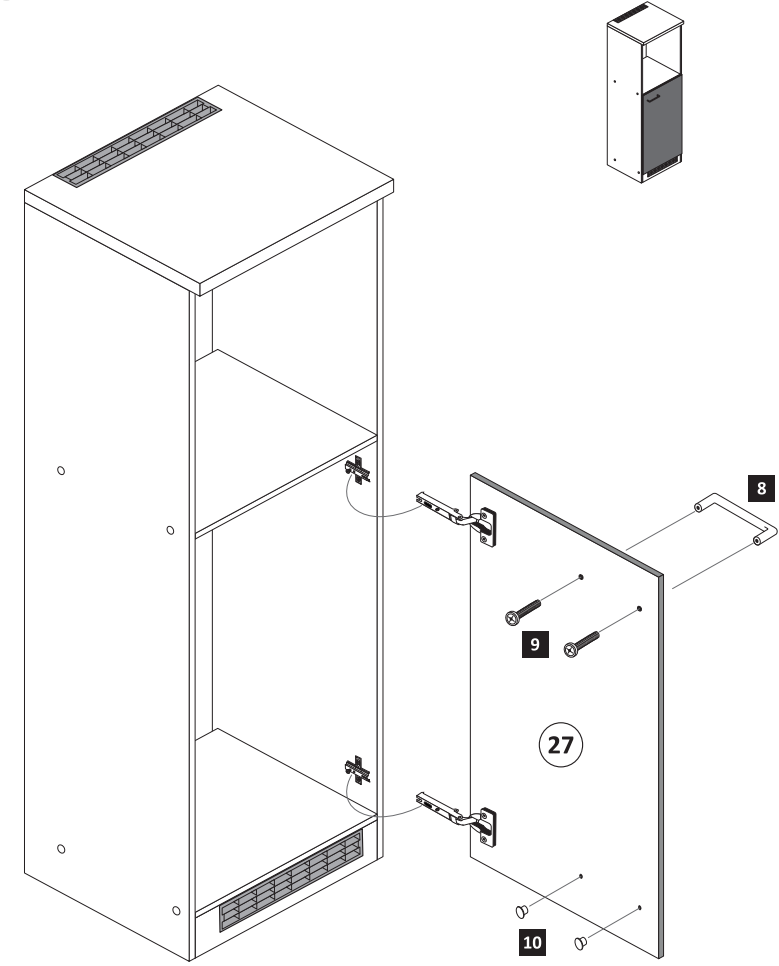

6

- 7 3,5 x 15 2 x 2804
- 12 2 x 2845
- 13 4 x 15 2 x 2810
- 14 4 x 45 2 x 2814
- 15 6 x 34 2 x 2844

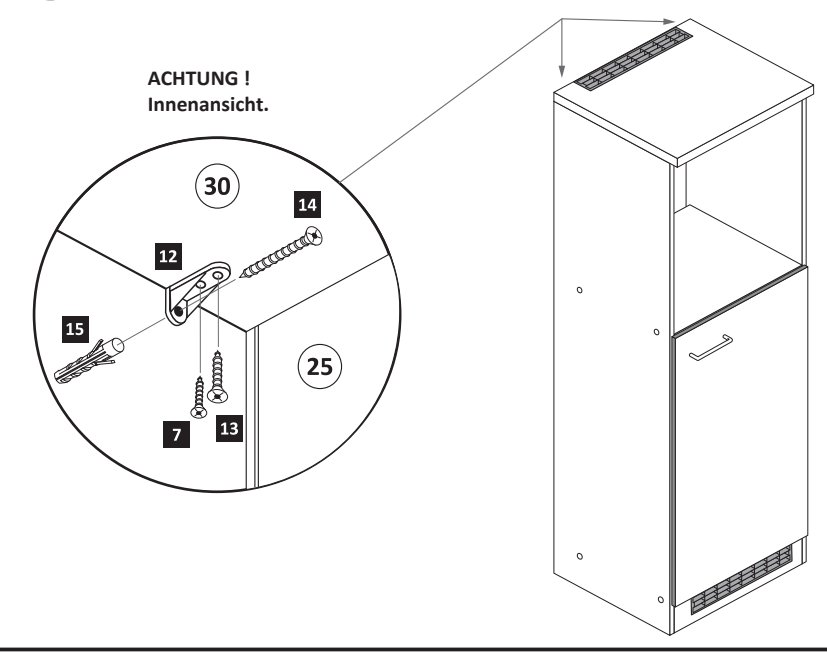

ACHTUNG!
 Innenansicht.

7

- 16 4 x 9 2 x
- 5 x 30 1 x

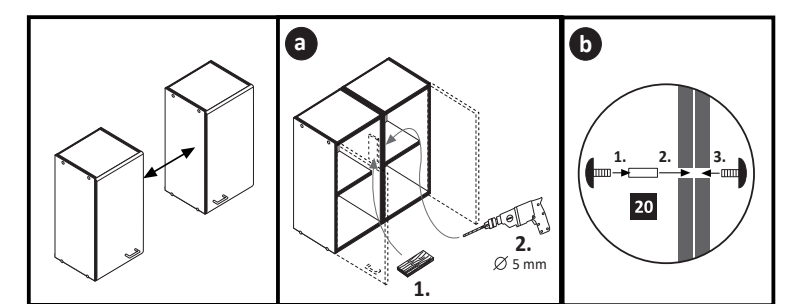



1 4 x 2827	2 4 x	3 2 x 1503	4 2 x 1611	5 4 x 2804
6 8 x 30 20 x 2861	7 6,3 x 11 4 x 2815	8 5/5 x 16 4 x 2821	9 5mm 2 x 2855	10 M4 x 9 2 x 2835
11 2 x	12 4 x	13 2 x 5265	14 4 x 9 5 x 30 2 x 1 x	15 10 x 2862
16 4 x 2865	19 1 x	20 1 x	21 1 x	22 1 x
23 1 x	24 1 x	25 1 x	26 1 x	27 1 x
28 1 x	29 1 x 2863	30 4 x 30 4 x 2830		

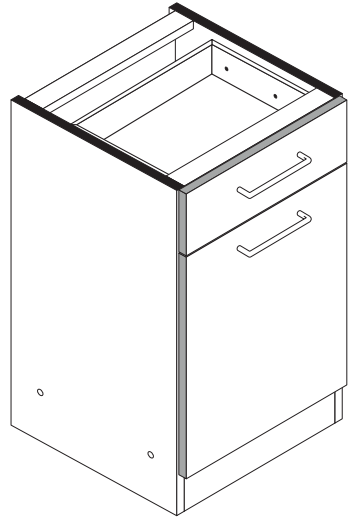
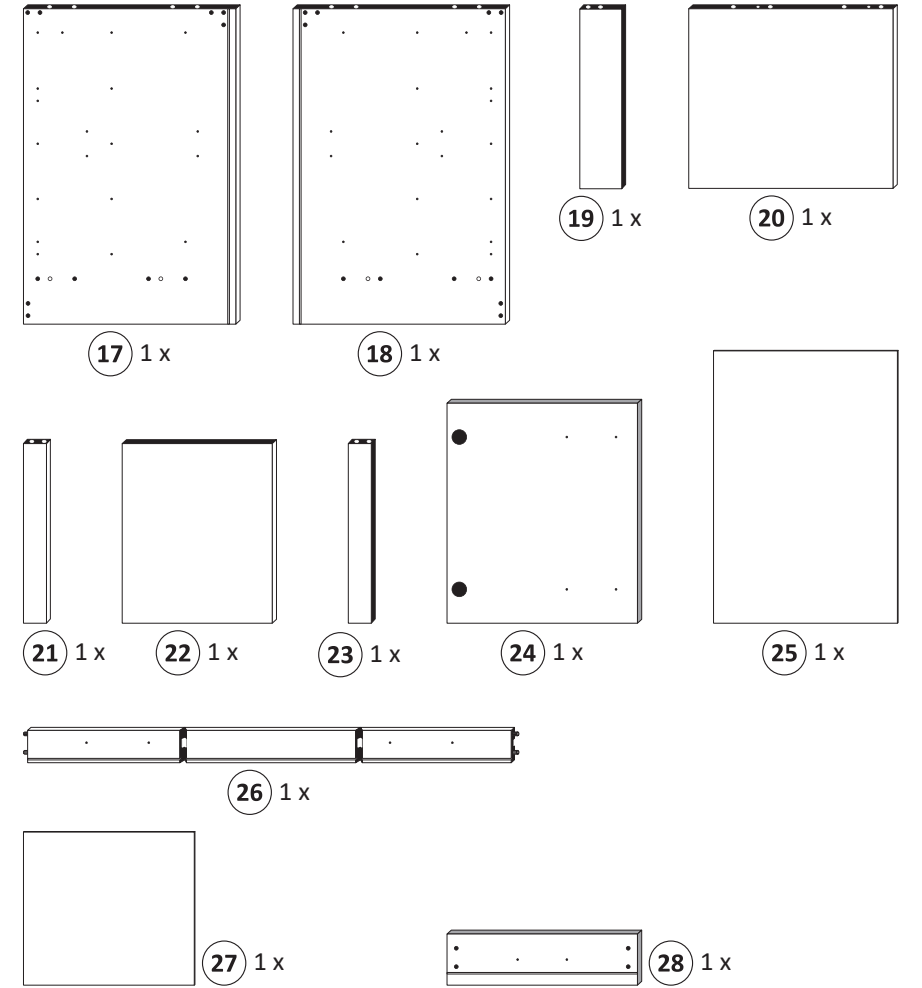
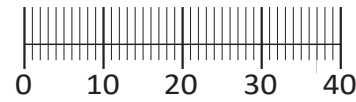

87112.510

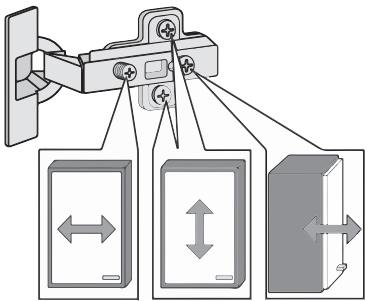
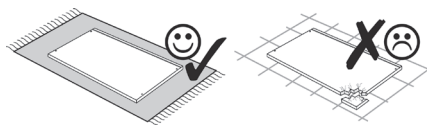
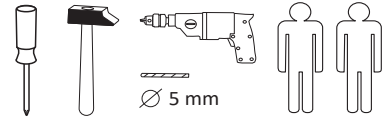

Das beigegefügte Wandbefestigungsmaterial (Dübel und Schrauben) eignet sich nur für festes Mauerwerk (z.B.: Beton- oder Ziegelwände). Für andere Wandaufbauten sind eventuell Spezialdübel und andere Schrauben notwendig. Ziehen Sie gegebenenfalls eine Fachkraft zu Rate.

De beigeleidende wandmontage hardware (pluggen en schroeven) is alleen geschikt voor massief metselwerk (bijvoorbeeld beton of bakstenen muren). Voor andere muur structuren zijn eventueel bijzondere ankerbouten en andere noodzakelijke. Draai indien nodig, een deskundige.

Приложенный материал для крепления к стене (дюбели и винты) пригоден только для жестких кладок (например, бетонные или кирпичные стены). Для других настенных конструкций необходимы смотря по обстоятельствам специальные дюбели и другие винты. При необходимости проконсультируйтесь у специалиста.

Le mur d'accompagnement matériel de montage (chevilles et les vis) ne convient que pour la maçonnerie solide (par exemple en béton ou des murs de briques). Pour les structures de mur d'autres sont peut-être spéciale boulons d'ancrage et d'autres nécessaires. Serrer le cas échéant, un expert.

Załączony materiał do mocowania do ściany (kolki rozprężne i wkręty) nadaje się tylko do ścian murowanych (np. z betonu lub cegieł). Do ścian wykonanych w innych technologiach konieczne być mogą specjalne kolki rozprężne i inne wkręty. W razie potrzeby skorzystaj z fachowej pomocy

Il muro di accompagnamento hardware di montaggio (tasselli e viti) è adatto solo per muratura piena (ad esempio calcestruzzo o muratura). Per le altre strutture murarie sono forse speciali bulloni di ancoraggio e necessari di altri. Serrare se necessario, un esperto.

The accompanying wall mounting hardware (anchors and screws) is suitable only for solid masonry (eg concrete or brick walls). For other wall structures are possibly special anchor bolts and other necessary. Tighten if necessary, an expert.

Ekteki duvara sabit montaj malzemeleri (dübel ve vidalar), sadece sağlam duvarlar için (örnek: beton veya tuğla) elverişlidir. Başka duvarlar için özel dübeller ve farklı vidalar gerekebilir. Gerektiğinde bir uzmana danışınız.

1

4 2 x 1611	7 6,3 x 11 4 x 2815	8 5/5 x 16 4 x 2821	13 2 x 5265	29 1 x 2863
------------------	------------------------------	------------------------------	-------------------	-------------------

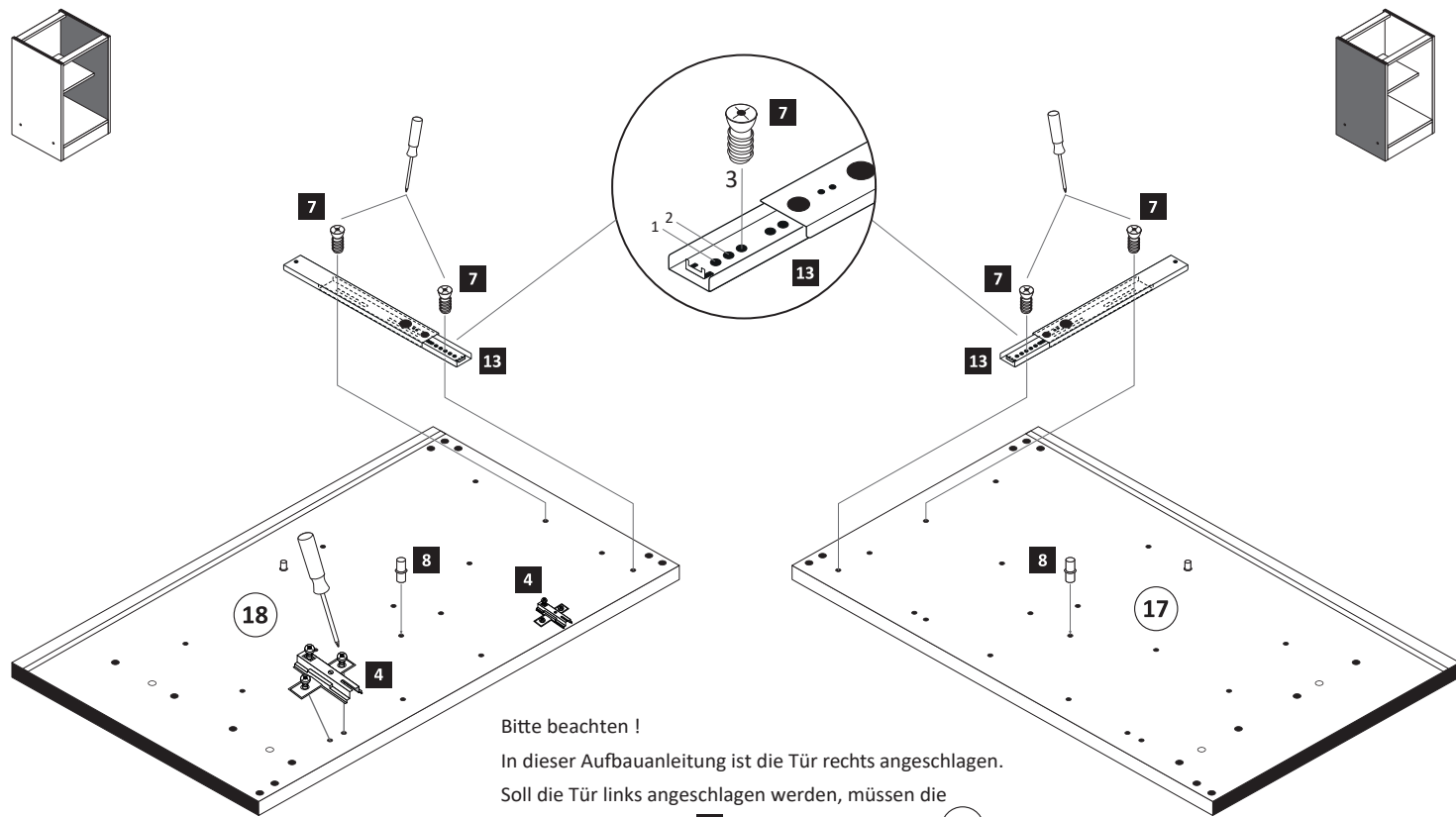

Bitte beachten!
In dieser Aufbauanleitung ist die Tür rechts angeschlagen.
Soll die Tür links angeschlagen werden, müssen die Kreuzmontageplatten 4 auf das linke Seitenteil 17 montiert werden.

2

6 8 x 30 20 x 2861	29 1 x 2863
-----------------------------	-------------------

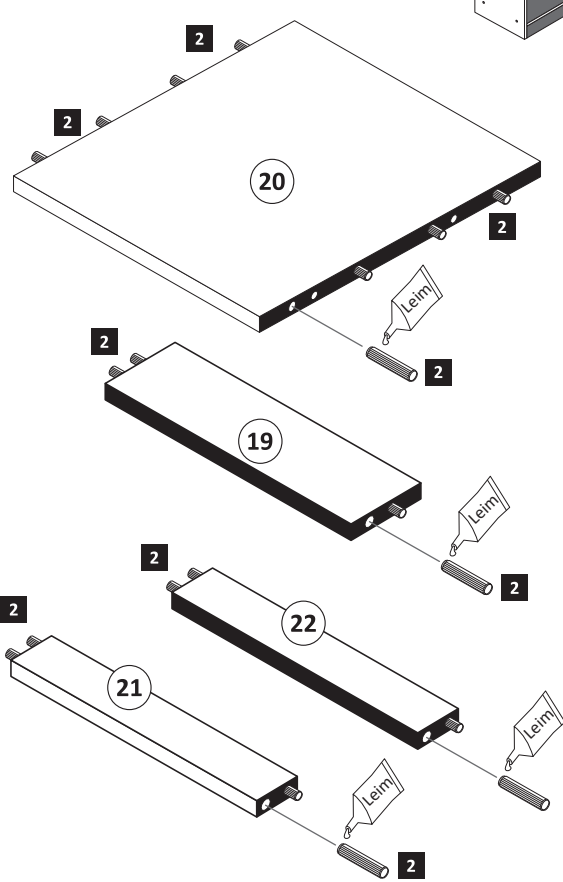

3

3 2 x 1503	5 3,5 x 15 4 x 2804	16 2 x 2865
------------------	------------------------------	-------------------

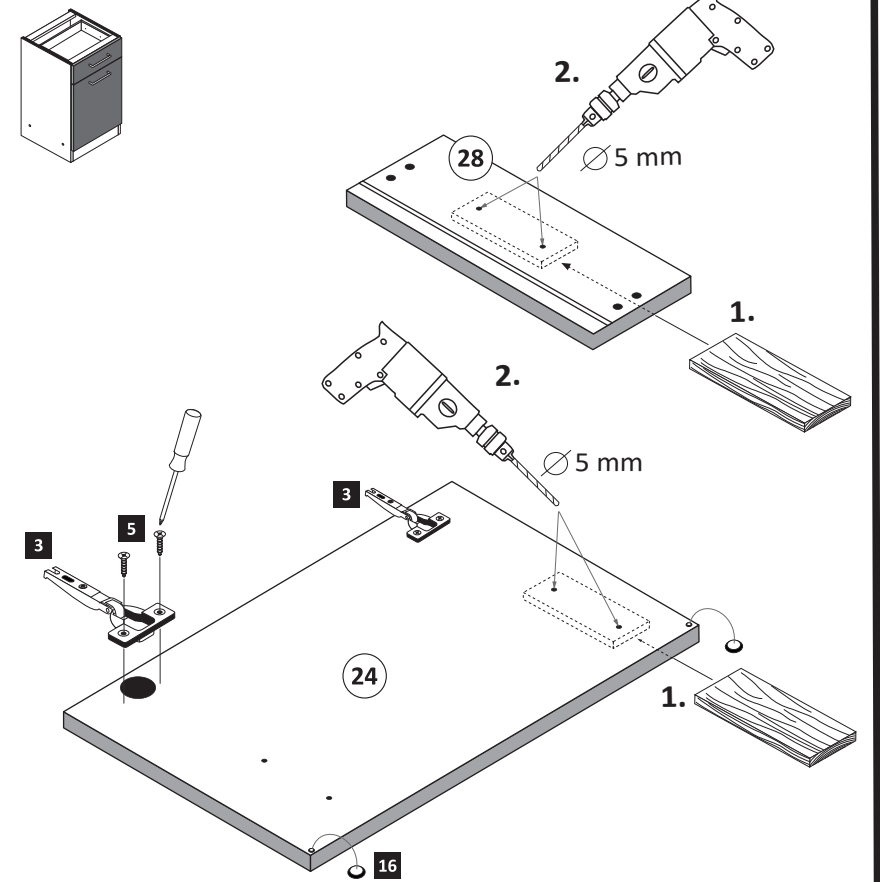

4

11	1 x
12	2 x
16	2 x 2865
29	1 x 2863

Leim

1.

2.

5

1	4 x 2827
2	4 x
29	1 x 2863

Leim

20 min.

D Leim
GB Glue
NL Lijm
PL Klej
TR Tutkal
F Colle
I Colla

1 2

Ø 5 mm

29

23

21

18

17

20

19

6

15	10 x 2862
----	-----------

25

25

7

10	M4 x 9	2 x 2835
----	--------	----------

10

13

28

22

8

9	5mm	2 x 2855
11	1 x	
12	4 x 27	2 x 2829

9

11

12

24

9

14	4 x 9	5 x 30	2 x	1 x
----	-------	--------	-----	-----

a

b

1.

2. Ø 5 mm

14

1.

2.

3.

Silikon

! Tipp !
Versiegeln Sie die Küche gegen eventuell eindringende Feuchtigkeit. (Silikon nicht im Lieferumfang enthalten)



87153.530

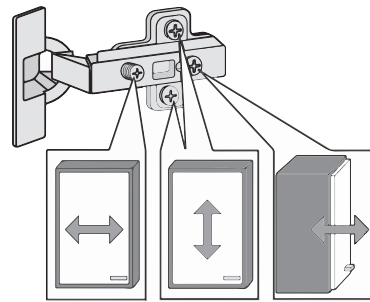
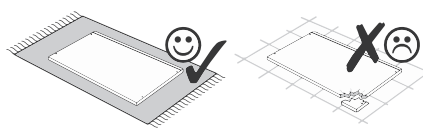
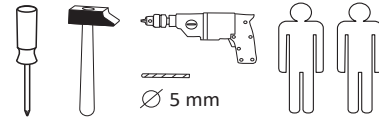

1 4 x 2827	2 4 x	3 2 x 1503	4 2 x 1611	5 1 x
6 2 x	7 5mm 2 x 2855	8 8 x 30 16 x 2861	9 3,5 x 15 6 x 2804	10 6,3 x 11 2 x 2815
11 2 x 2845	12 6,3 x 16 2 x 2816	13 2 x 2865	14 3,5 x 30 4 x 2807	15 10 x 2862
16 2 x 2849	25 4 x 9 2 x	5 x 30 1 x	26 1 x 2863	

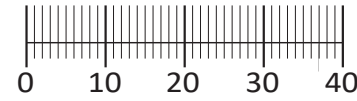

Das beigefügte Wandbefestigungsmaterial (Dübel und Schrauben) eignet sich nur für festes Mauerwerk (z.B.: Beton- oder Ziegelwände). Für andere Wandaufbauten sind eventuell Spezialdübel und andere Schrauben notwendig. Ziehen Sie gegebenenfalls eine Fachkraft zu Rate.

Приложенный материал для крепления к стене (дюбели и винты) пригоден только для жестких кладок (например, бетонные или кирпичные стены). Для других настенных конструкций необходимы смотря по обстоятельствам специальные дюбели и другие винты. При необходимости проконсультируйтесь у специалиста.

Załączony materiał do mocowania do ściany (kolki rozprężne i wkręty) nadaje się tylko do ścian murowanych (np. z betonu lub cegieł). Do ścian wykonanych w innych technologiach konieczne być mogą specjalne kolki rozprężne i inne wkręty. W razie potrzeby skorzystaj z fachowej pomocy.

The accompanying wall mounting hardware (anchors and screws) is suitable only for solid masonry (eg concrete or brick walls). For other wall structures are possibly special anchor bolts and other necessary. Tighten if necessary, an expert.

De begeleidende wandmontage hardware (pluggen en schroeven) is alleen geschikt voor massief metselwerk (bijvoorbeeld beton of bakstenen muren). Voor andere muur structuren zijn eventueel bijzondere ankerbouten en andere noodzakelijke. Draai indien nodig, een deskundige.

Le mur d'accompagnement matériel de montage (chevilles et les vis) n'est adapté que pour la maçonnerie solide (par exemple en béton ou des murs de briques). Pour les structures de mur d'autres sont peut-être spéciale boulons d'ancrage et d'autres nécessaires. Serrer le cas échéant, un expert.

Il muro di accompagnamento hardware di montaggio (tasselli e viti) è adatto solo per muratura piena (ad esempio calcestruzzo o muratura). Per le altre strutture murarie sono forse speciali bulloni di ancoraggio e necessari di altri. Serrare se necessario, un esperto.

Ekteki duvara sabit montaj malzemeleri (dübel ve vidalar), sadece sağlam duvarlar için (örnek: beton veya tuğla) elverişlidir. Başka duvarlar için özel dübeller ve farklı vidalar gerekebilir. Gerektiğinde bir uzmana danışınız.

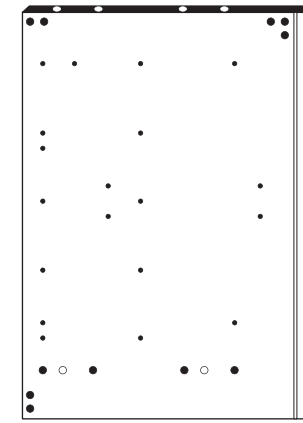

17 1 x

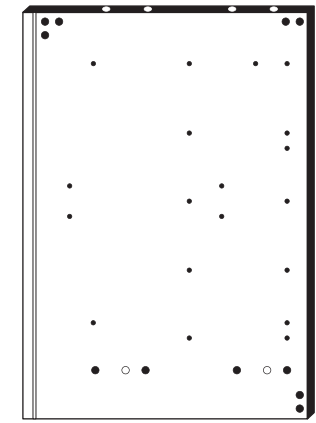

18 1 x



19 1 x



20 1 x

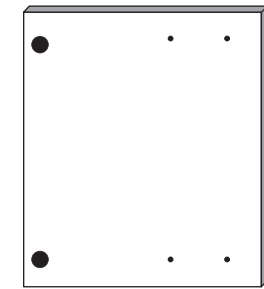

21 1 x

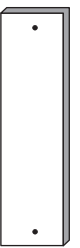

22 1 x



23 1 x



24 1 x

1



Bitte beachten!
In dieser Aufbauanleitung ist die Tür rechts angeschlagen. Soll die Tür links angeschlagen werden, müssen die Kreuzmontageplatten 4 auf das linke Seitenteil 17 montiert werden.

4 2 x 1611	9 3,5 x 15 2 x 2804	10 6,3 x 11 2 x 2815	11 2 x 2845	16 2 x 2849
------------------	------------------------------	-------------------------------	-------------------	-------------------

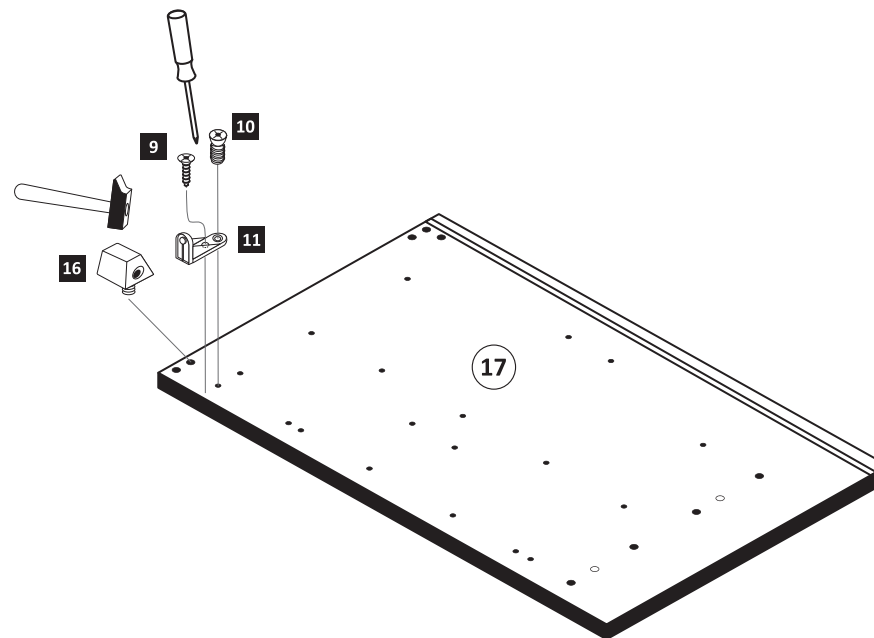
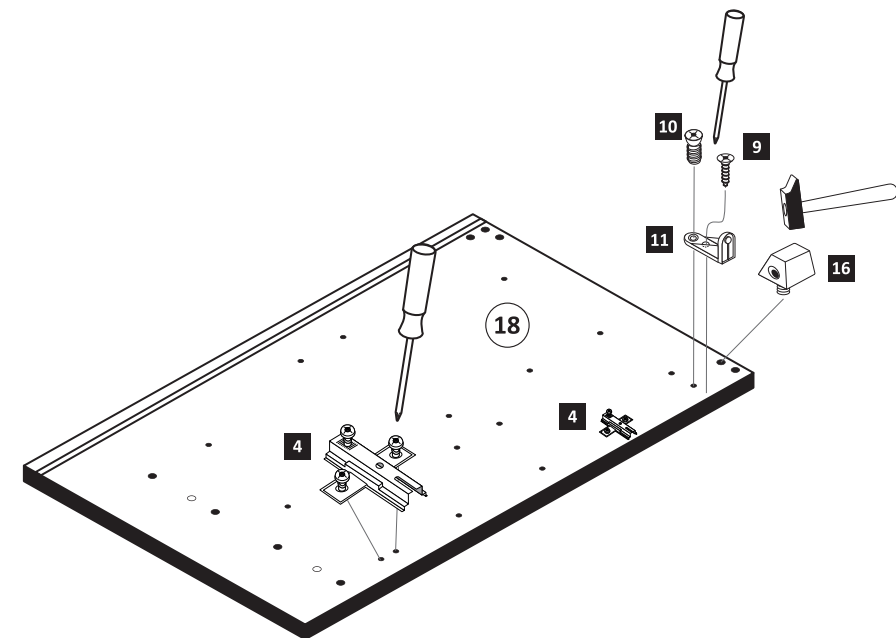

2



8 8 x 30 16 x 2861	26 1 x 2863
-----------------------------	-------------------

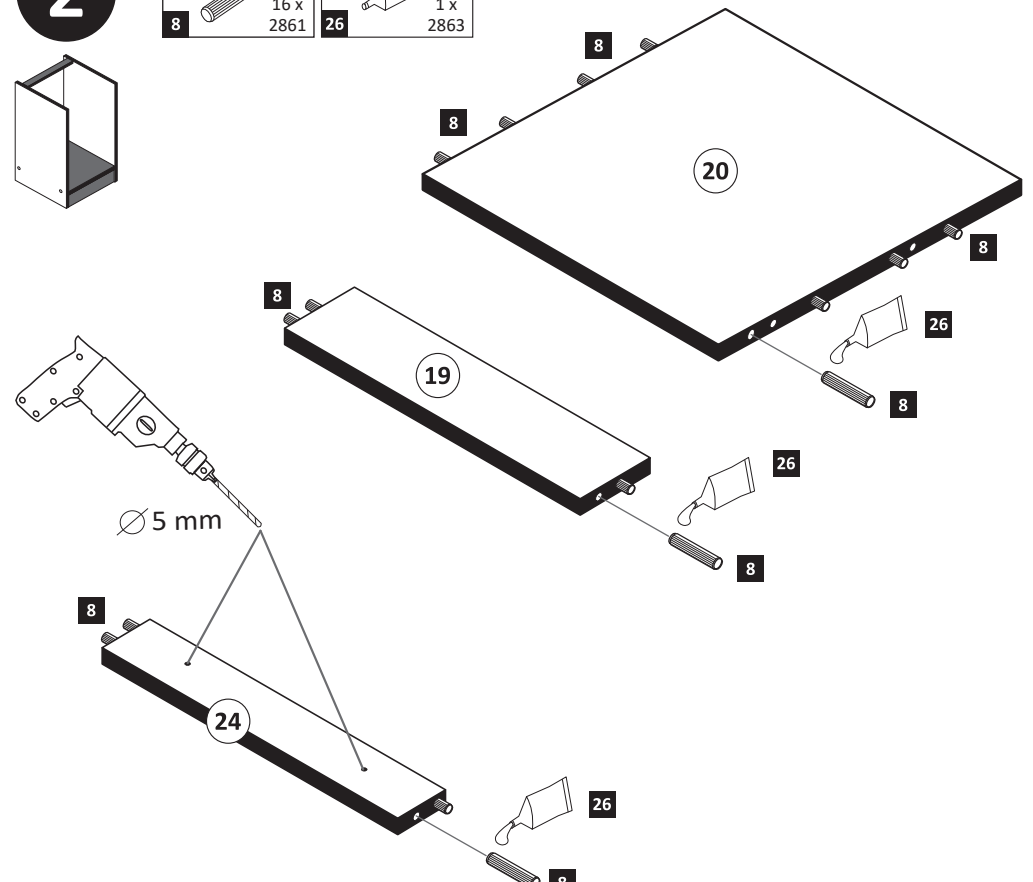

3

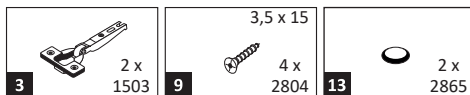

ACHTUNG!
Montagebeispiel
Rechtsanschlag!
Bei Linksanschlag
andere Griffbohrung
durchbohren!

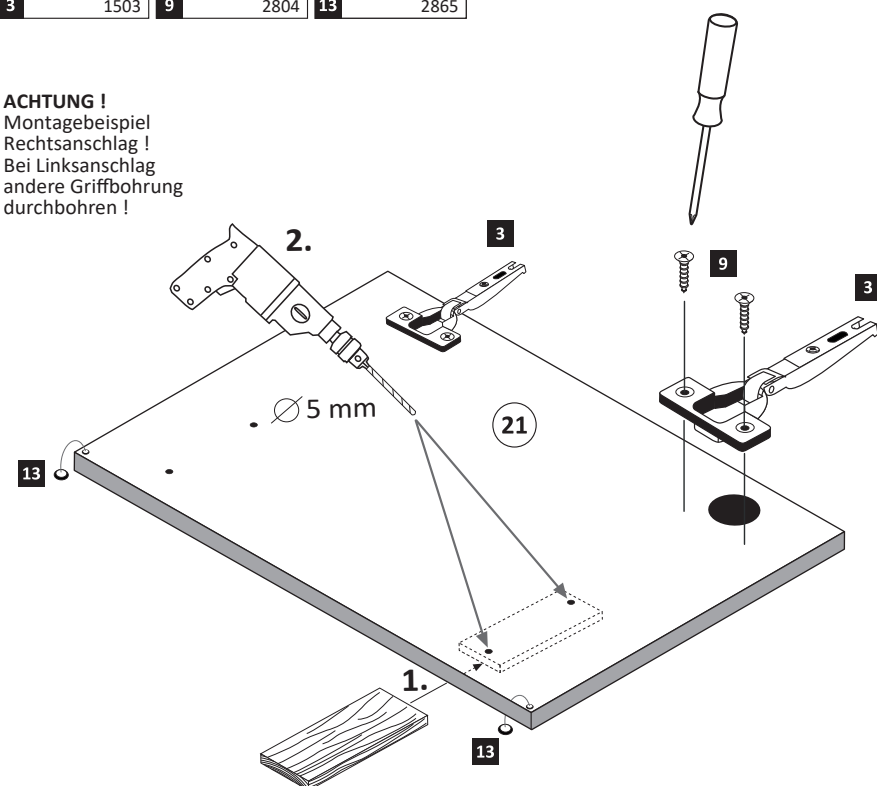
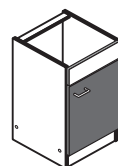

4

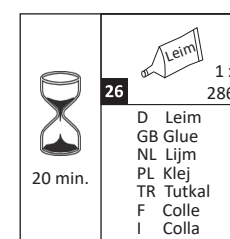
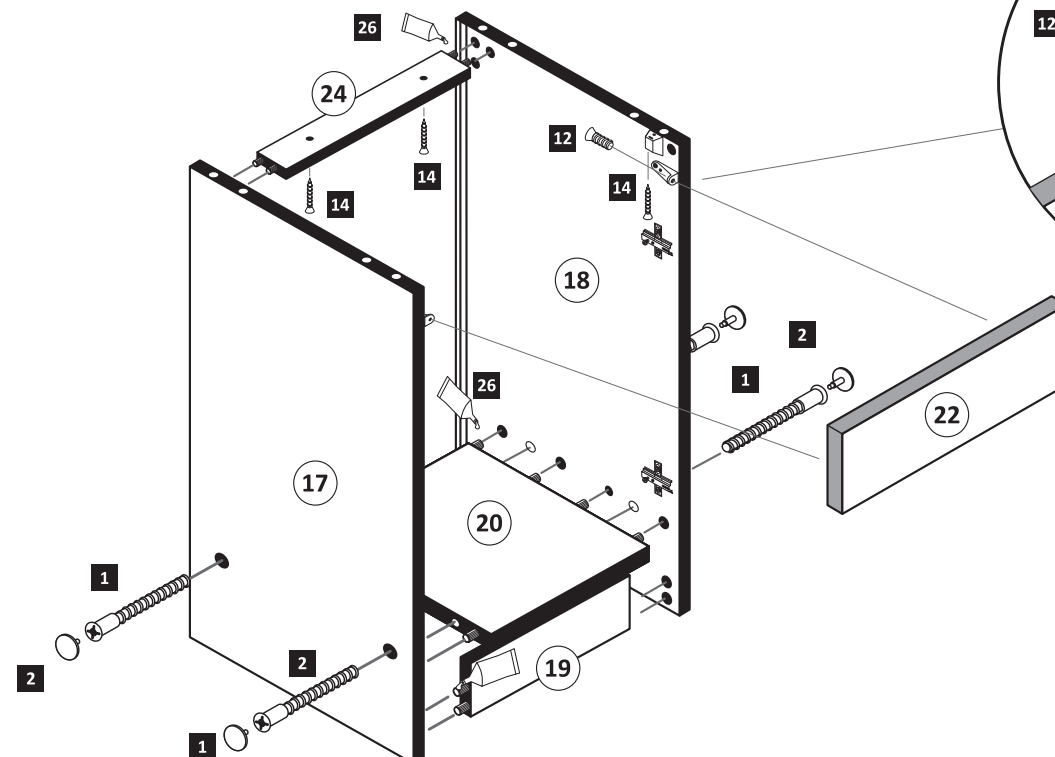

5

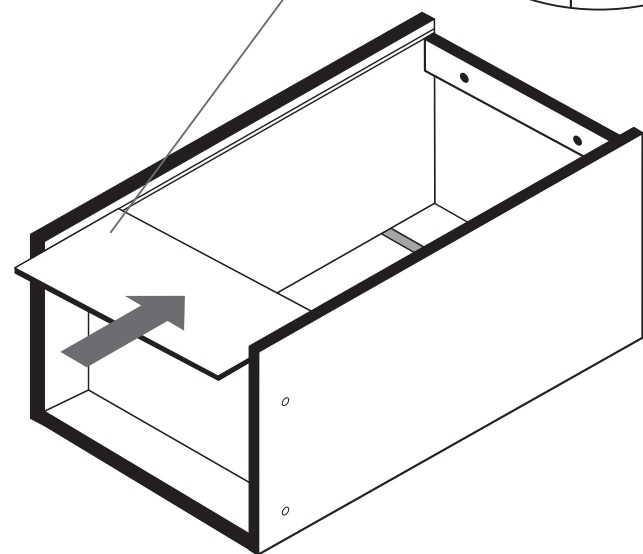
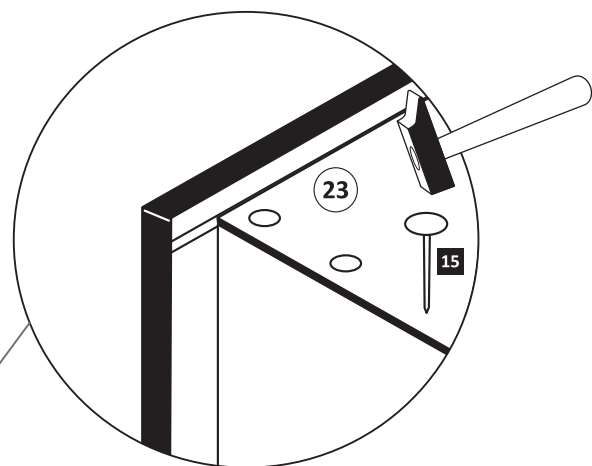
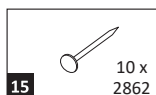

6

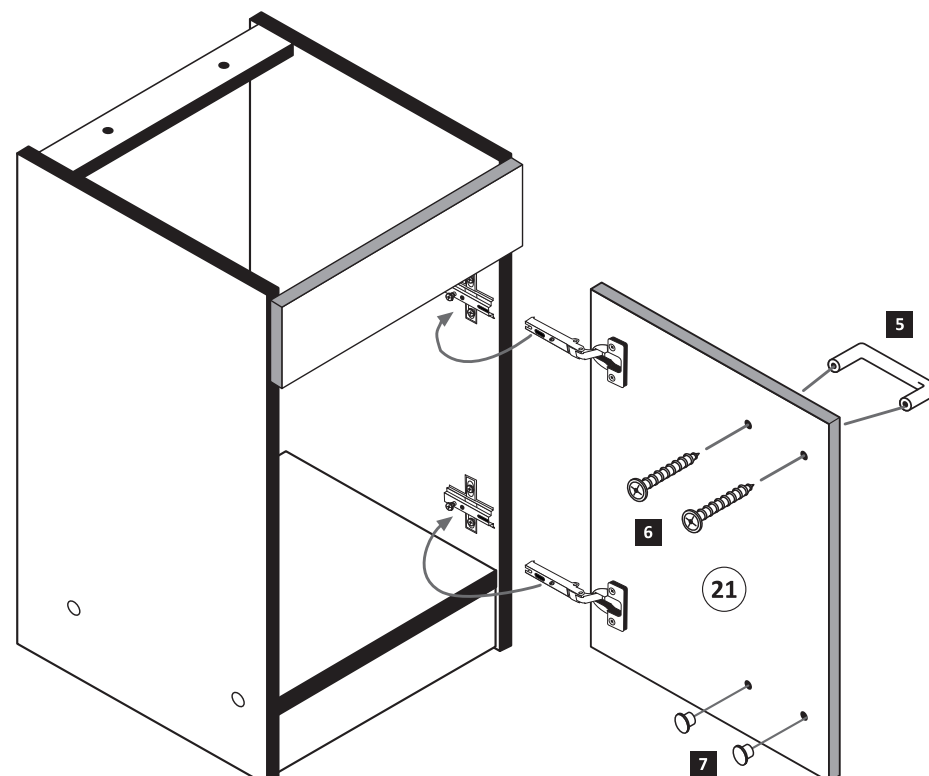
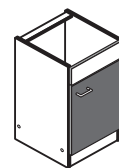

7

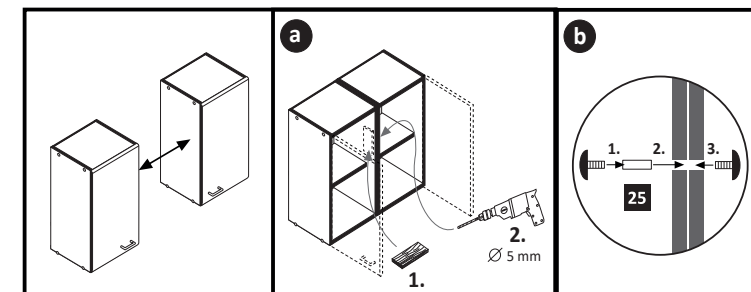
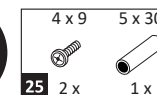

! Tipp!

Versiegeln Sie die Küche wie
abgebildet gegen eventuell
eindringende Feuchtigkeit.

(Silikon nicht im Lieferumfang enthalten)

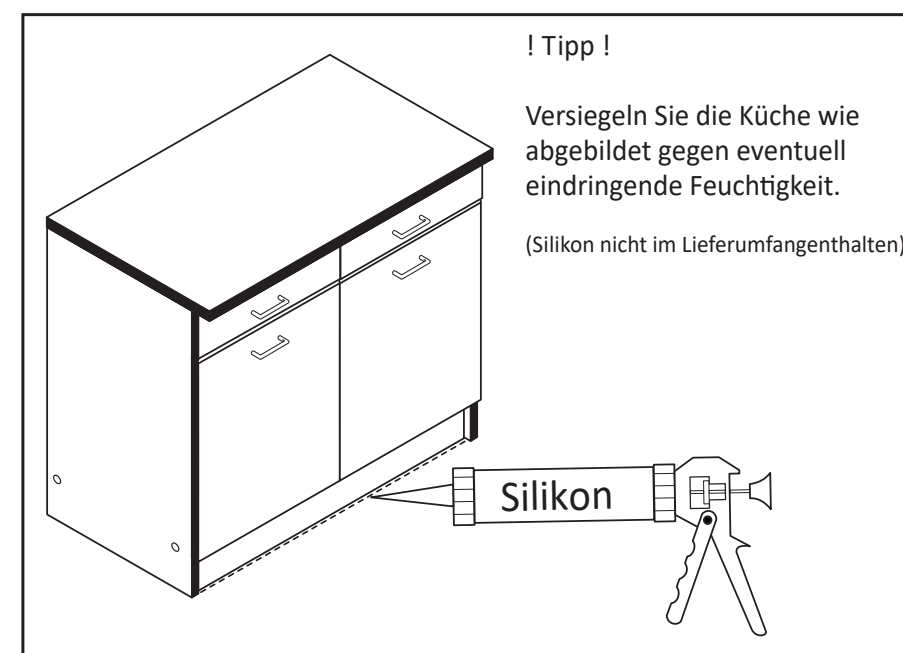

Beschlagteile

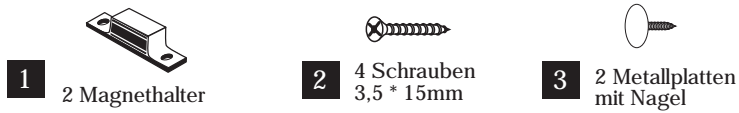

Bauteile

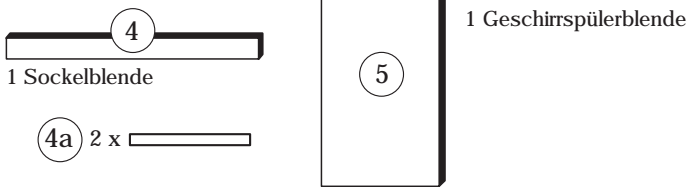
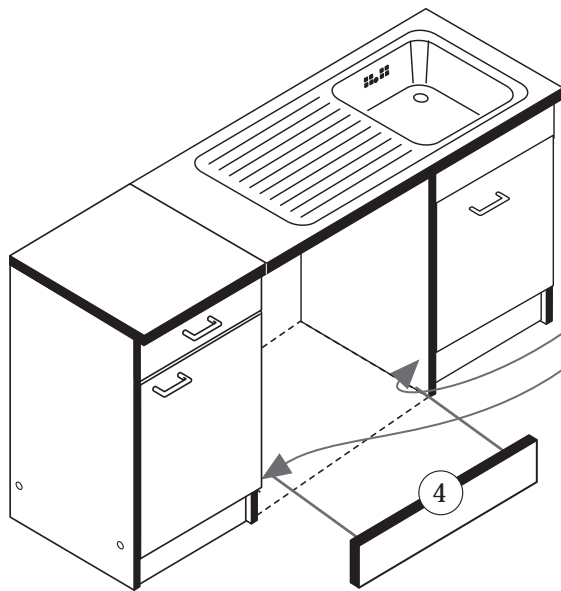
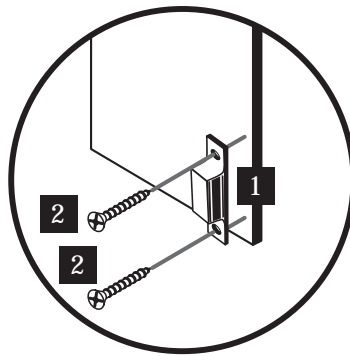
**A****a****b**

Wenn Sie die Möglichkeit haben, den linken Magnethalter an einen anderen Schrank zu montieren, dann gehen Sie so vor, wie in Variante (a). Sollten Sie die Möglichkeit nicht haben, dann kleben Sie den Geschirrspülerpülsocket (26) mit Hilfe der mitgelieferten Klebestreifen an den Geschirrspüler.

Bei der Geschirrspülfrontmontage gehen Sie bitte nach Hersteller Angaben vor.

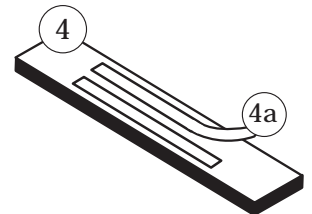
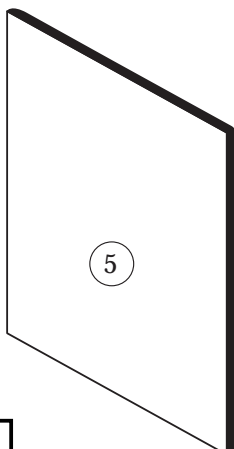
**B**

Die Anleitung zur Montage der Geschirrspülerblende an den Geschirrspüler entnehmen Sie bitte der Montageanleitung des Geschirrspülerherstellers.

