

## PARTS LIST

### MAIN FRAME PARTS

1. TH123-1  
Bed  
(1 Piece)
2. TH123-2  
Sides Panel  
(2 pieces)
3. TH123-3  
Front Panel  
(1 Piece)
4. TH123-4  
Back Panel  
(1 Piece)
5. TH123-5  
10\*350-4 Wheels  
(4 pieces)

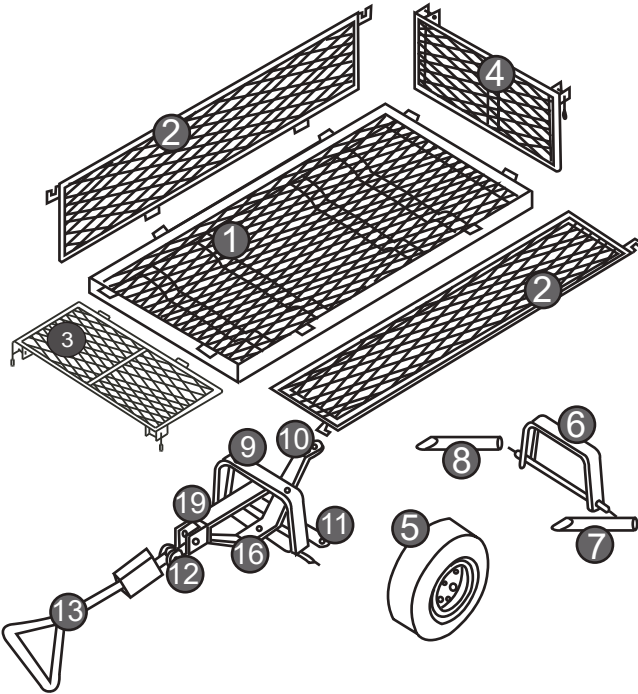

### REAR SUPPORT ASSEMBLY

6. TH123-6  
Rear Axle Support  
(1 piece)
7. TH123-7  
Left Rear Axle Brace  
(1 Piece)
8. TH123-8  
Right Rear Axle Brace  
(1 Piece)

### FRONT SUPPORT ASSEMBLY

9. TH123-9  
Front Axle Support  
(1 Piece)
10. TH123-10  
Centre Front Axle Brace  
(1 Piece)
11. TH123-11  
Steering Link Connector  
(1 Piece)
12. TH123-12  
Plastic Coupling  
(1 Piece)
13. TH123-13  
Pull Handle  
(1 Piece)
14. TH123-14  
Side Panel R-Clip  
(8 Pieces)

15. TH123-15  
Screws 8\*16mm  
(10 Pieces)

### ASSEMBLY HARDWARE

- |  |   |
|--|---|
| 16. TH123-16 Long Steering Assembly Shoulder Bolts Screws<br>6*20mm(1 piece) | 21. TH123-21 Splint<br>4.5mm (1 Piece)  |
| 17. TH123-17 Wheel Acorn Nuts<br>12mm (4 Pieces)                             | 22. TH123-22<br>Left Lock Handles (2 pieces)<br>Right Lock Handles (2 pieces) |
| 18. TH123-18 Wheel Washers<br>12mm (4 Pieces)                                | 23. TH123-23 Screws<br>6*16mm (3Pieces)                                       |
| 19. TH123-19 Brace<br>(1 Piece)  | 24. TH123-24 PVC Bag<br>(1 Piece)   |
| 20. TH123-20 Pull Handle Bolt Screws<br>8*60mm(1 Piece)                      | 25. TH123-25 Grid<br>(1 Piece)  |

EN

401418

# 550KG GARDEN CART

## ORIGINAL INSTRUCTION MANUAL



RETAIN FOR FUTURE REFERENCE

TecTake GmbH,  
Tauberweg 41, D-97999 Igersheim, Germany

ASSEMBLY

1. Lay the Bed with the underside facing up

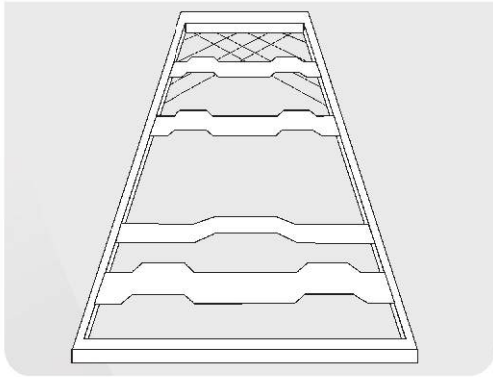

2. Fix the Rear Axle Support to the Bed using 2 of combination 15 in the order shown below

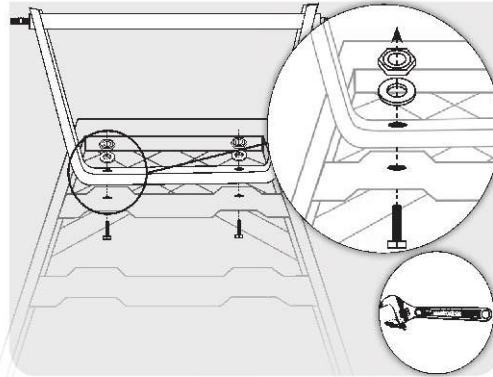

3. Slot the arms of the Rear Axle Braces on to the ends of the Rear Axle Support bar

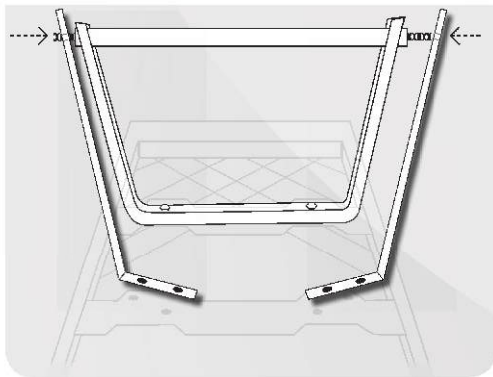

4. Fix the angled arms of the Rear Axle Braces to the Bed using 4 of the combination 15

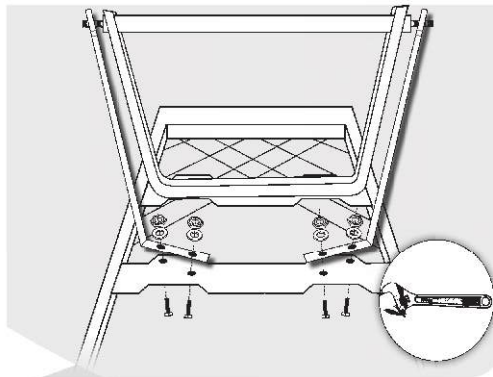

5. Fix the Front Axle Support to the Bed using 2 of combination 15 in the order shown below

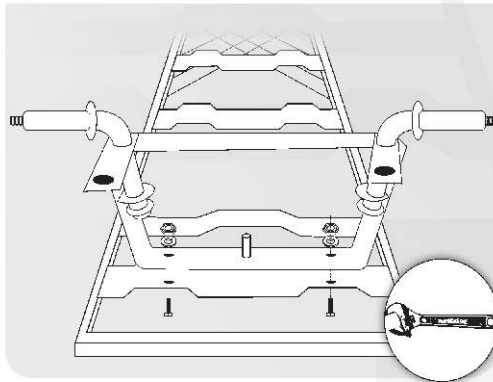

6. Fix the Front Axle Joint under the arms of the Front Axle Support using 2 of combination 23

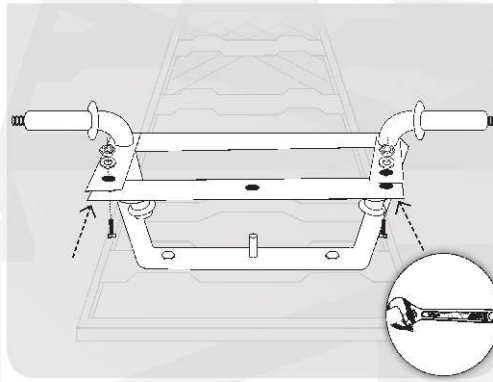

7. Position the Steering Brace to the Front Axle Support and Bed as shown below

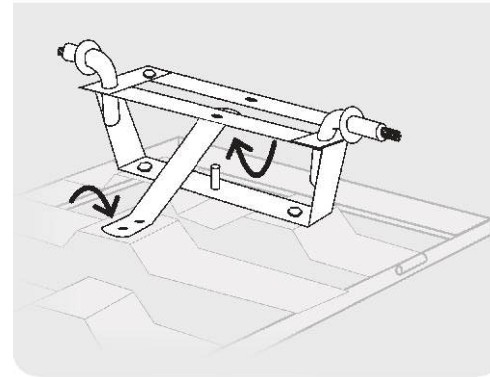

8. Fix the Steering Brace to the Bed using 2 of combination 15 as shown below

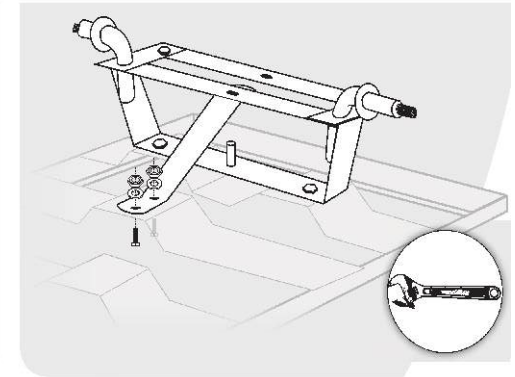

9. Slot the stepped arm of the Centre Axle Brace on to the protruding cylinder on the Front Axle Support

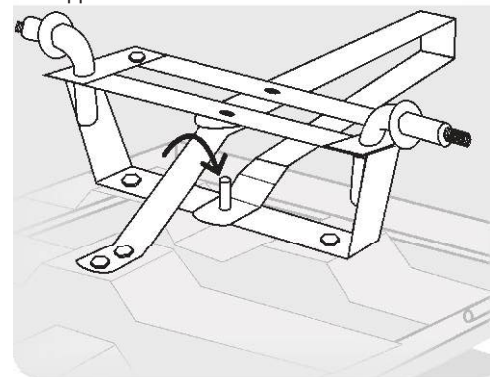

10. Position the straight arm to the Centre Axle Brace between the Steering Joint and Front Axle Support

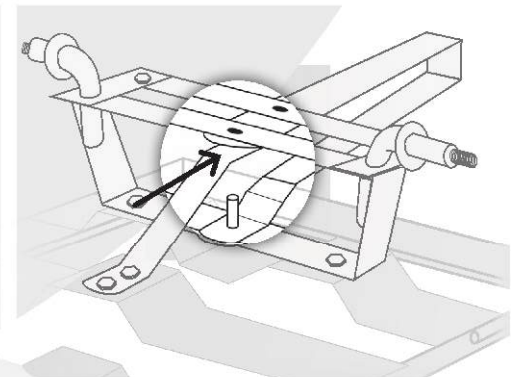

11. Fix the Steering Brace and Centre Axle Brace to the Front Axle Support using combination 16

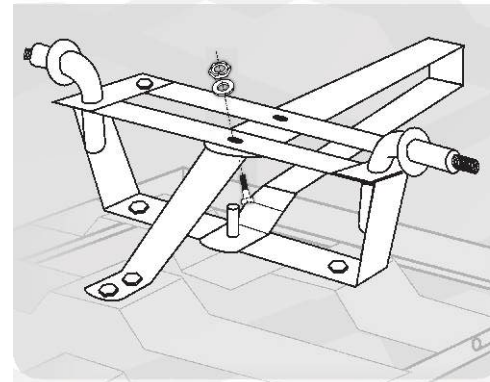

12. Fix the Centre Axle Brace to the Front Axle Joint using combination 23

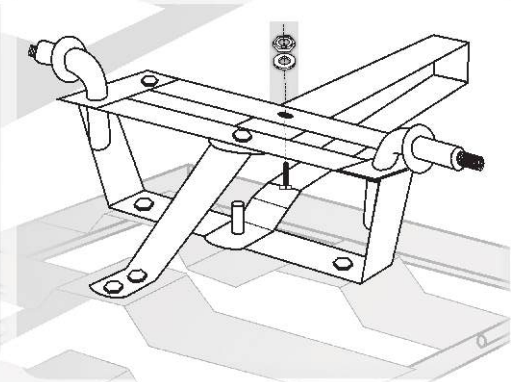

13. Push the Split Pin 21 Through the protruding cylinder on the Front Axle Support and Split open to secure

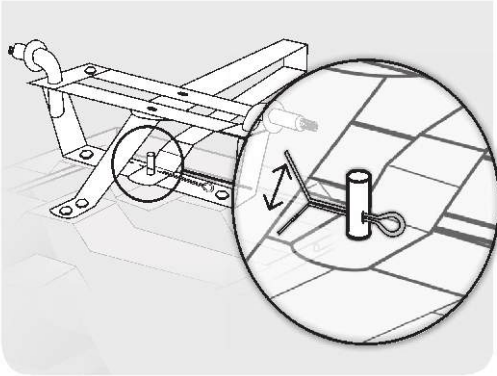

14. Attach the U-shaped end of the Steering Bar to the Centre Axle Brace with 20

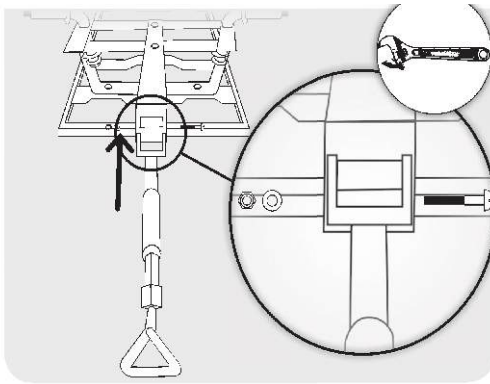

15. Attach the 4 Tyres to the Axle Supports using 17/18 on each as shown below

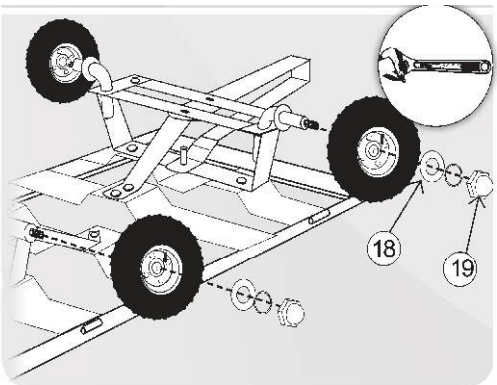

16. Turn the Trolley over so the wheels are touching the ground

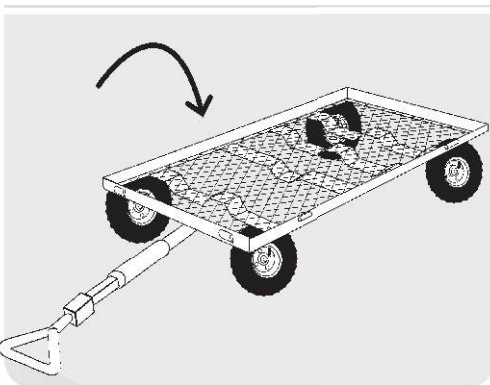

17. Attach the Front, Rear and Side Panels to the Bed by pushing the Cotter Pins 14 through the 2 the hinges on the outer side of each panel and the bed. Do this for all panels, fit 2 on each side.hown below

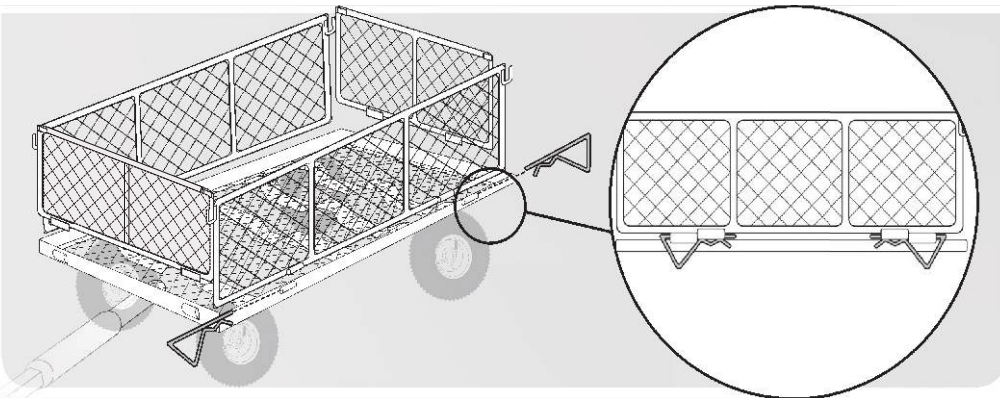

18. To secure the frame, hook the locking Handles 22 through the U-shaped hinges welded to the tops of the side panels as shown below

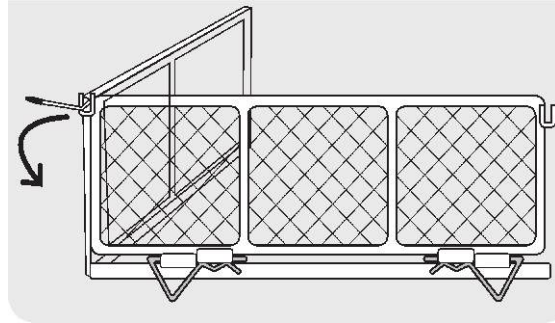

19. Insert the Heavy Duty Plastic Liner into the interior of the Trolley and secure through the mesh with Press Studs.

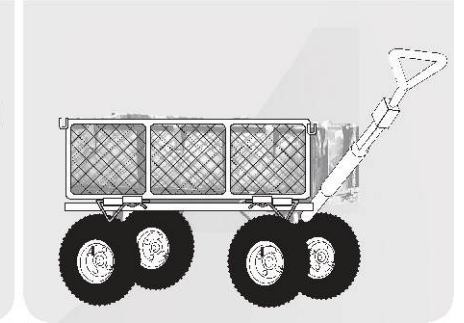

### Assembly Diagram

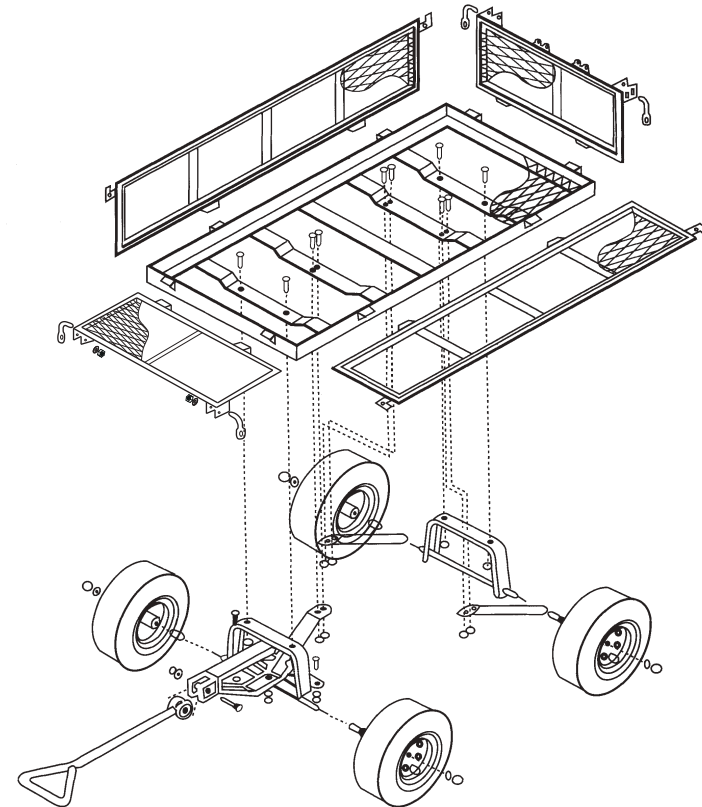

# STÜCKLISTE

## TEILE DES HAUPTTRAHMENS

1. TH123-1  
Bett  
(1 Stück)
2. TH123-2  
Seitenwände  
(2 Stück)
3. TH123-3  
Vorderwand  
(1 Stück)
4. TH123-4  
Rückwand  
(1 Stück)
5. TH123-5  
10\*350-4 Räder  
(4 Stück)

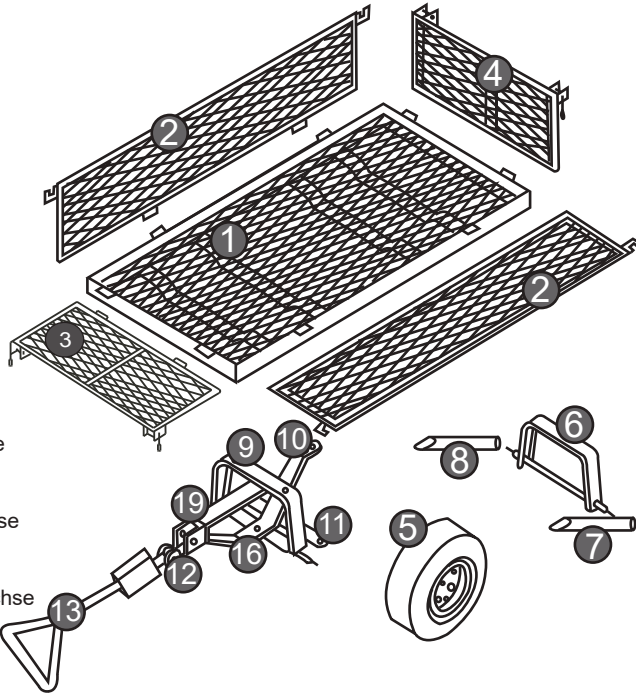

## MONTAGETRÄGER HINTEN

6. TH123-6  
Unterstützung der Hinterachse  
(1 Stück)
7. TH123-7  
Klammer der linken Hinterachse  
(1 Stück)
8. TH123-8  
Klammer der rechten Hinterachse  
(1 Stück)

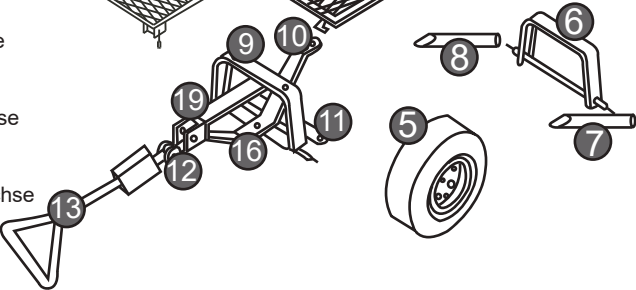

## MONTAGETRÄGER VORNE

9. TH123-9  
Unterstützung der Vorderachse  
(1 Stück)
10. TH123-10  
Klammer der mittleren Vorderachse  
(1 Stück)
11. TH123-11  
Lenker-Anschluss  
(1 Stück)
12. TH123-12  
Kunststoff-Kupplung  
(1 Stück)
13. TH123-13  
Zuggriff  
(1 Stück)
14. TH123-14  
Seitenwände R-Clip  
(8 Stück)

## MONTAGE HARDWARE

- |  |  |
|--|--|
| 16. TH123-16 Lange Lenkung Montage Passschrauben<br>6*20mm (1 Stück) | 21. TH123-21 Schiene<br>4,5 mm (1 Stück)   |
| 17. TH123-17 Hutmuttern für die Räder<br>12mm (4 Stück)              | 22. TH123-22 Linker Hebelverschluss<br>(2 Stück)<br>Rechter Hebelverschluss<br>(2 Stück) |
| 18. TH123-18 Unterlegscheiben für die Räder<br>12mm (4 Stück)        | 23. TH123-23 Schrauben<br>6*16mm (3 Stück)   |
| 19. TH123-19 Klammer<br>(1 Stück)                                    | 24. TH123-24 PVC-Tasche<br>(1 Stück)   |
| 20. TH123-20 Ziehgriff Bolzen Schrauben<br>8*60 mm (1 Stück)         | 25. TH123-25 Gitter<br>(1 Stück)   |

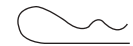

15. TH123-15  
Schrauben 8\*16mm  
(10 Stück)



# 550KG Gartenwagen

## ÜBERSETZUNG DER ORIGINALBETRIEBSANLEITUNG



FÜR KÜNFTIGE VERWENDUNG AUFBEWAHREN

TecTake GmbH,  
Tauberweg 41, D-97999 Igersheim, Germany

# MONTAGE

1. Legen Sie das Bett mit der Unterseite nach oben hin.

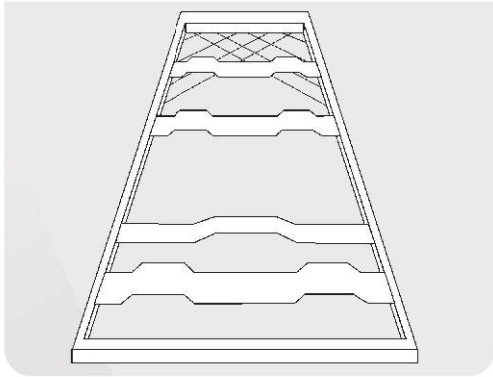

2. Befestigen Sie die Unterstützung der Hinterseite am Bett mit 2 von Kombination 15 in der unten dargestellten Reihenfolge.

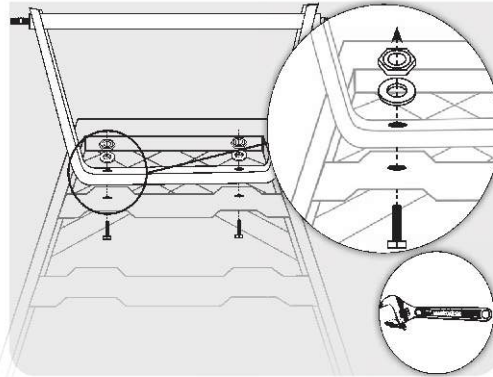

3. Stecken Sie die Arme der Klammern der Hinterachse in die Enden der Stützschiene der Hinterachse

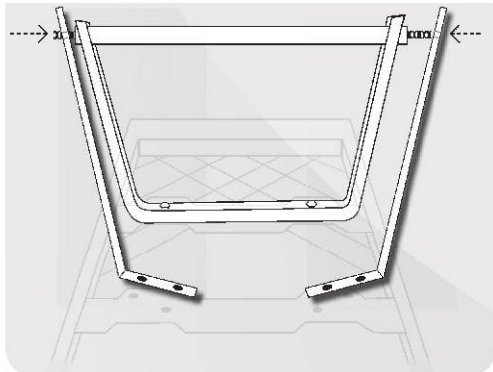

4. Befestigen Sie die angewinkelten Arme der Klammer der Hinterachse am Bett mit 4 von Kombination 15

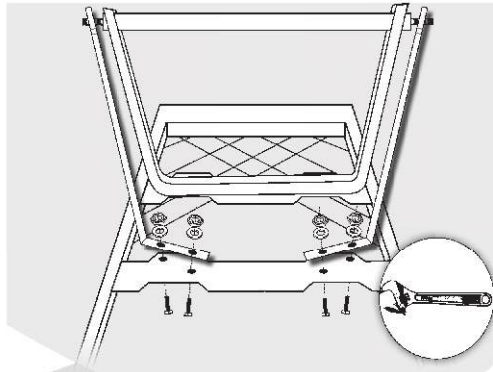

5. Befestigen Sie die Stützschiene der Vorderachse am Bett mit 2 von Kombination 15 in der unten angegebenen Reihenfolge.

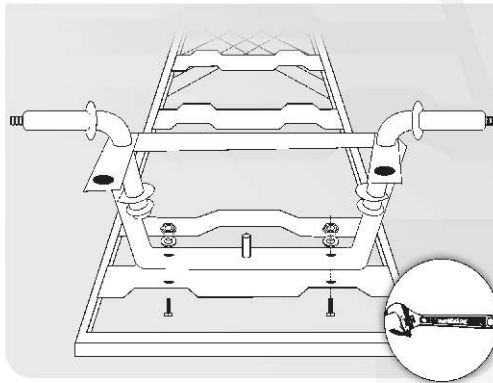

6. Befestigen Sie das Gelenk der Vorderachse unter den Armen der Stützschiene der Vorderachse mit 2 von Kombination 23.

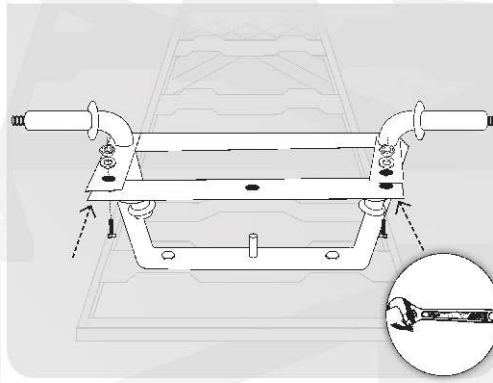

7. Positionieren Sie die Lenkklammer an der Stützschiene der Vorderachse und dem Bett, wie unten dargestellt.

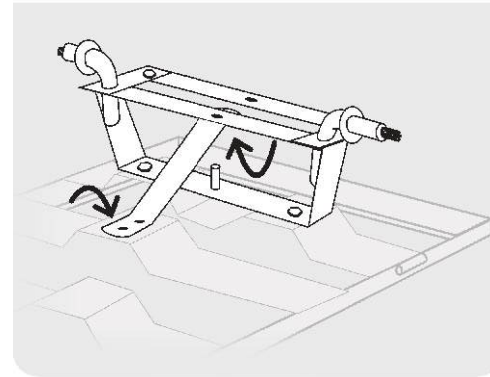

8. Befestigen Sie die Lenkklammer am Bett mit 2 von Kombination 15, wie unten dargestellt

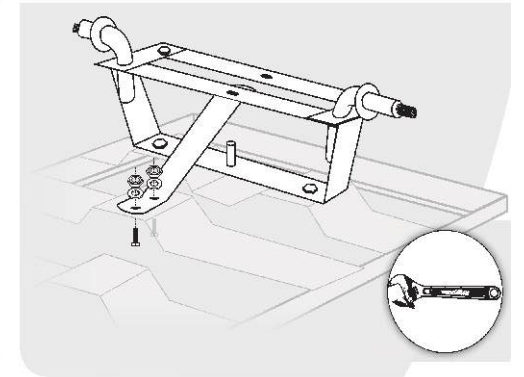

9. Stecken Sie den abgestuften Arm an der Klammer der Mittelachse auf den überstehenden Zylinder auf der Halterung der Vorderachse

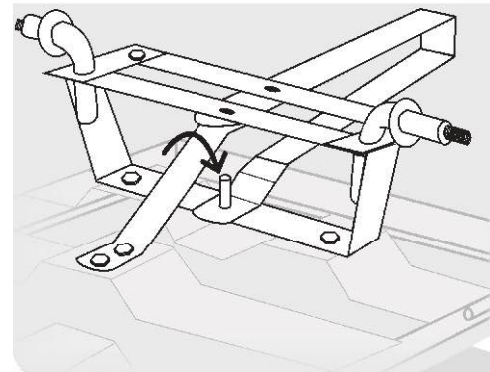

10. Positionieren Sie den geraden Arm an der Klammer der Mittelachse zwischen dem Steuerungsgelenk und der Halterung der Vorderachse

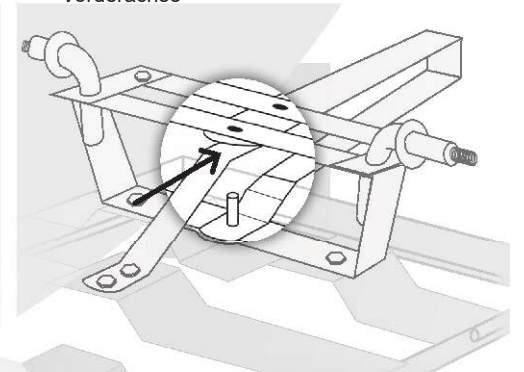

11. Befestigen Sie die Klammer der Lenkung und die Klammer der Mittleren Achse an der Halterung der Vorderachse mit Kombination 16

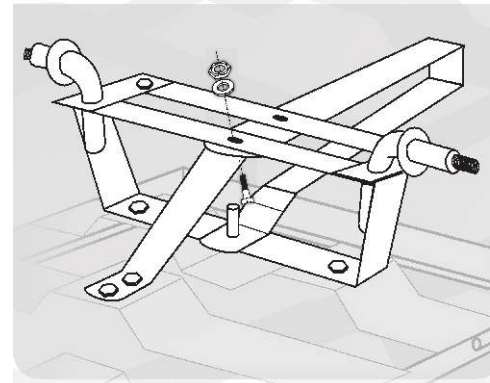

12. Befestigen Sie die Klammer der Mittleren Achse an dem Gelenk der Vorderachse mit Kombination 23

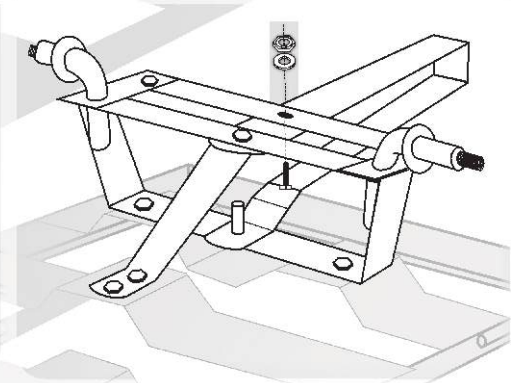

13. Drücken Sie den Federsplint 21 durch den überstehenden Zylinder auf der Halterung der Vorderachse und teilen Sie es auf, um es zu sichern.

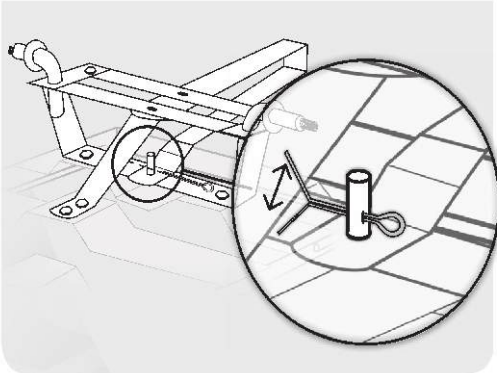

14. Befestigen Sie das u-förmige Ende der Lenkstange an der Klammer der Mittleren Achse mit 20

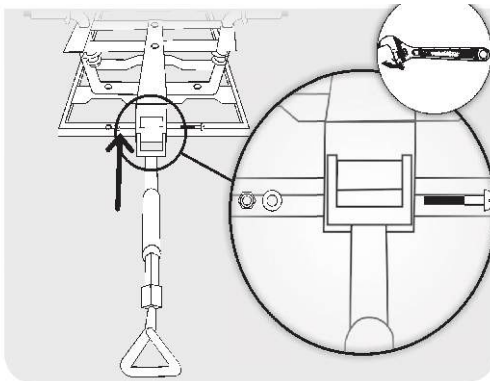

15. Befestigen Sie die 4 Reifen an der Achsenhalterung mit 17/18 auf jedem Reifen, wie unten dargestellt

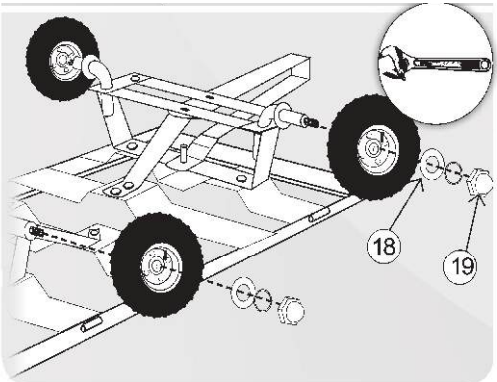

16. Drehen Sie den Wagen um, so dass die Räder auf dem Boden stehen.

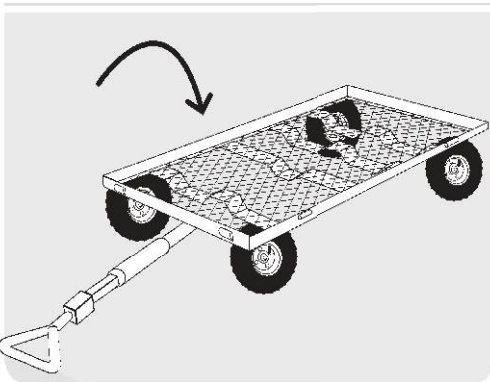

17. Befestigen Sie die Vorder-, Rück- und Seitenwände am Bett, indem Sie die Kurbelkeile 14 durch die beiden Scharniere an der Außenseite der Wände und des Betts drücken. Führen Sie das bei allen Wänden durch und befestigen Sie jeweils 2 auf jeder Seite.

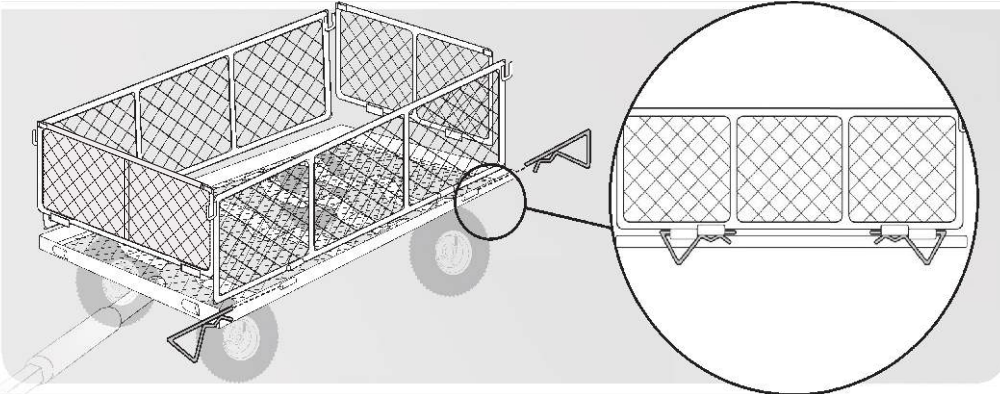

18. Um den Rahmen zu sichern, haken Sie die Feststellgriffe 22 durch die u-förmigen Scharniere, die an die Oberseiten der Außenwände geschweißt sind, so wie unten dargestellt.

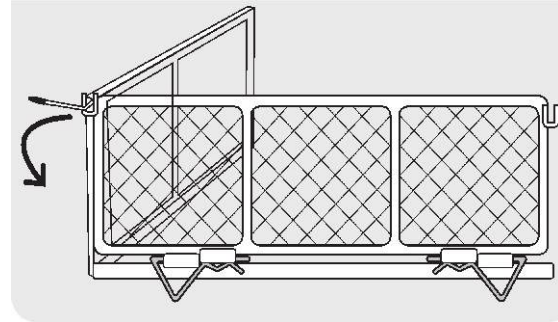

19. Legen Sie den Schwerlast-Kunststoffmantel in den Wagen und sichern Sie ihn am Gitter mit den Druckbügeln.

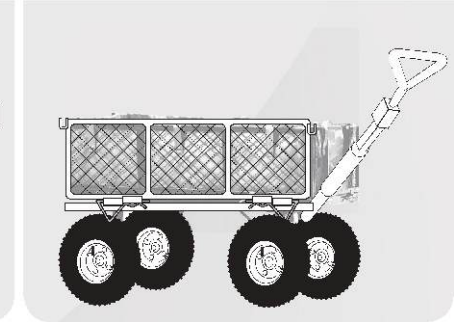

## Montageschema

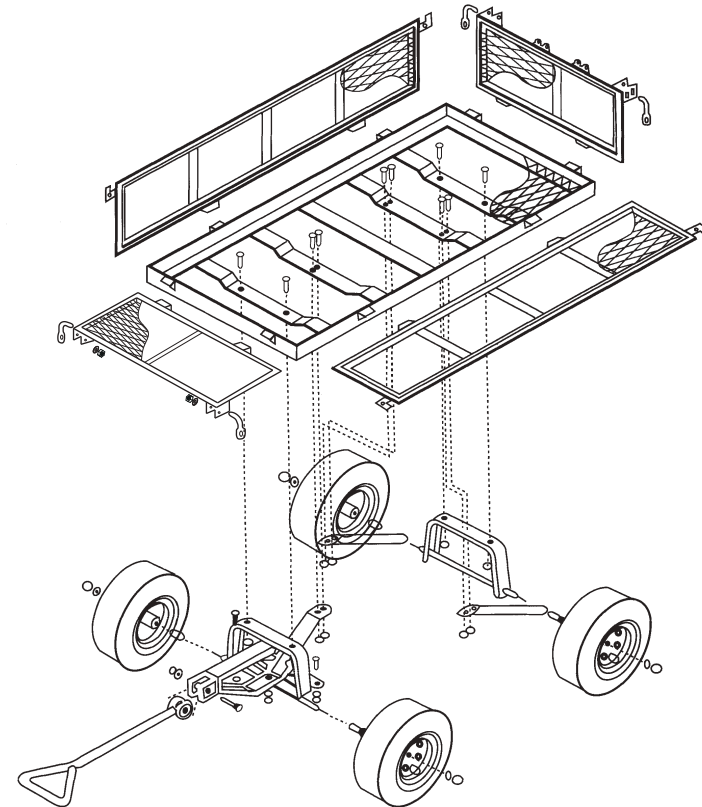

## PARTS LIST

### PIÈCES DE LA STRUCTURE PRINCIPALE

1. TH123-1  
Caisse  
(1 pièce)
2. TH123-2  
Panneaux latéraux  
(2 pièces)
3. TH123-3  
Panneau avant  
(1 pièce)
4. TH123-4  
Panneau arrière  
(1 pièce)
5. TH123-5  
10\*350-4 Roues  
(4 pièces)

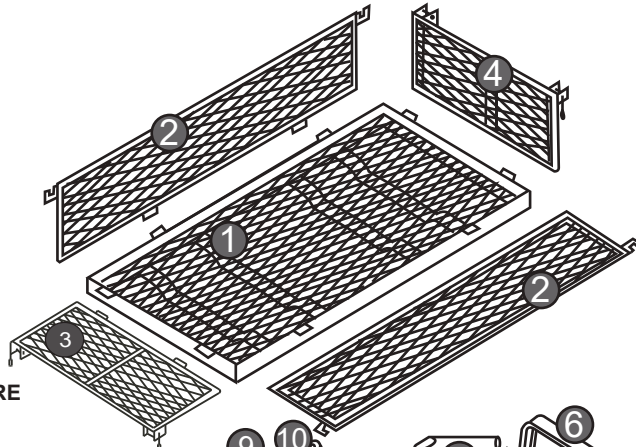

### ENSEMBLE SUPPORT ARRIÈRE

6. TH123-6  
Support d'essieu arrière  
(1 pièce)
7. TH123-7  
Stabilisateur d'essieu arrière gauche  
(1 pièce)
8. TH123-8  
Stabilisateur d'essieu arrière droit  
(1 pièce)

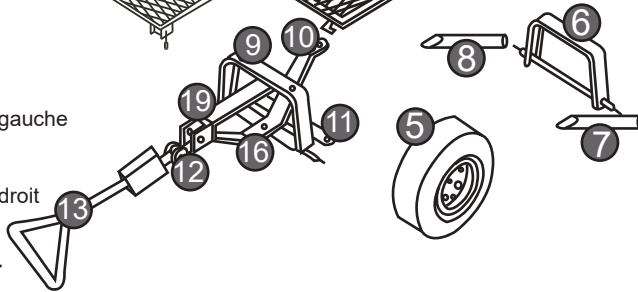





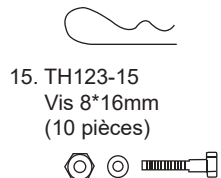





### ENSEMBLE SUPPORT AVANT

9. TH123-9  
Support d'essieu avant  
(1 pièce)
10. TH123-10  
Stabilisateur central essieu avant  
(1 pièce)
11. TH123-11  
Connecteur barre de direction  
(1 pièce)
12. TH123-12  
Couplage en plastique  
(1 pièce)
13. TH123-13  
Poignée  
(1 pièce)
14. TH123-14  
Goupilles en R panneau latéral  
(8 pièces)



### MATÉRIEL DE MONTAGE

- |  |  |
|--|--|
| 16. TH123-16 Boulon à épaulement fileté 6*200mm pour assemblage de la barre de direction (1 pièce) | 21. TH123-21 Goupille 4.5mm (1 pièce)  |
|                  |                  |
| 17. TH123-17 Écrous borgnes roue 12mm (4 pièces)   | 22. TH123-22 Poignées de verrouillage gauche (2 pièces), poignées de verrouillage droites (2 pièces) |
|                 |                  |
| 18. TH123-18 Rondelles de roue 12mm (4 pièces)   | 23. TH123-23 Vis 6*16mm (3 pièces)   |
|                 |                  |
| 19. TH123-19 Stabilisateur (1 pièce)   | 24. TH123-24 Sac en PVC (1 pièce)  |
|                 |                  |
| 20. TH123-20 Boulon fileté poignée 8*60mm (1 pièce)  | 25. TH123-25 la grille (1 pièce)   |
|                 |                  |

# 550KG CHARIOT DE JARDIN

TRADUCTION DU MODE D'EMPLOI ORIGINAL



A CONSERVER POUR UNE UTILISATION FUTURE

TecTake GmbH,  
Tauberweg 41, D-97999 Igersheim, Germany

## ASSEMBLAGE

1. Placez la caisse de manière à ce que la face inférieure soit orientée vers le haut.

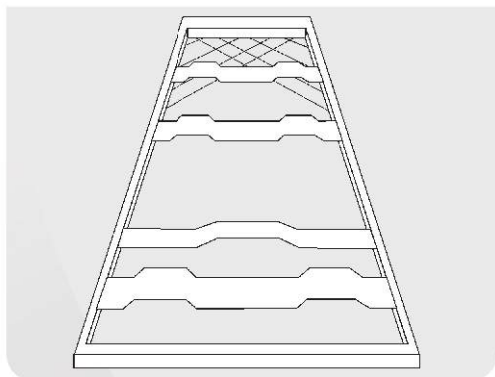

2. Fixez le support de l'essieu arrière sur la caisse du chariot à en utilisant 2 vis numéro 15 dans l'ordre montré ci-dessous

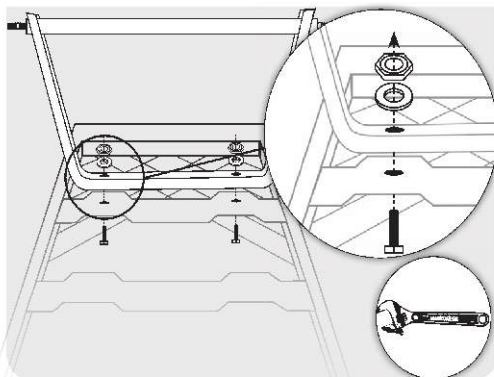

3. Insérez les bras de du stabilisateur de l'essieu arrière dans les embouts de la barre de support de l'essieu arrière

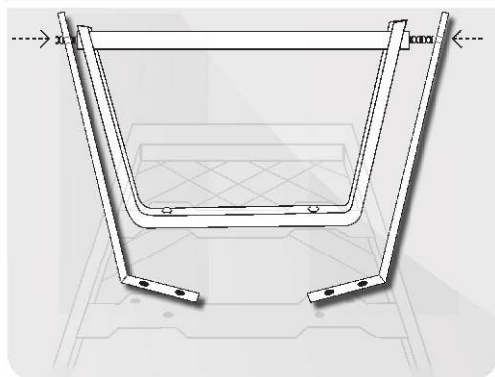

4. Fixez les bras coudés du stabilisateur de l'essieu arrière à la caisse en utilisant 4 vis numéro 15

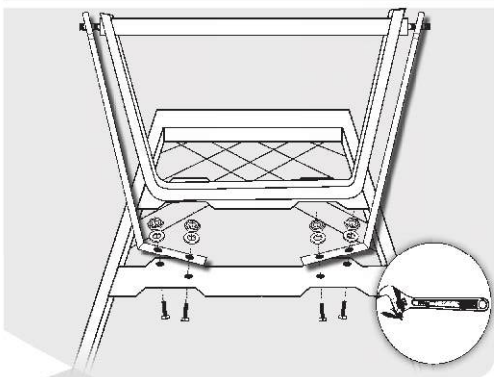

5. Fixez le support de l'essieu avant à la caisse en utilisant 2 vis numéro 15 dans l'ordre montré ci-dessous

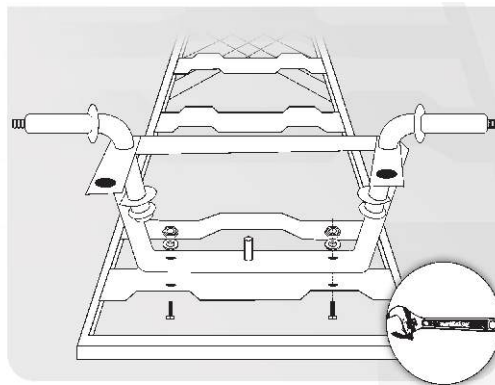

6. Fixez le joint de l'essieu avant sous les bras du support de l'essieu avant en utilisant 2 vis numéro 23

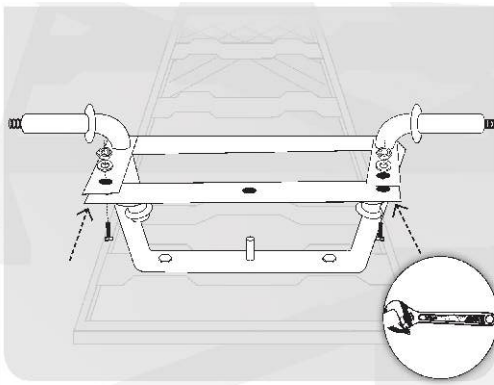

7. Positionnez le stabilisateur de direction avec le support de l'essieu avant et la caisse comme montré ci-dessous

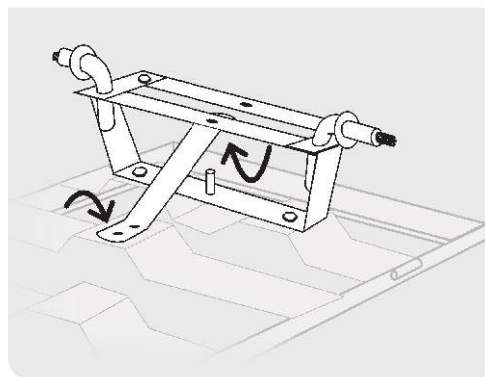

8. Fixez le stabilisateur de direction à la caisse en utilisant 2 vis numéro 15 comme montré ci-dessous

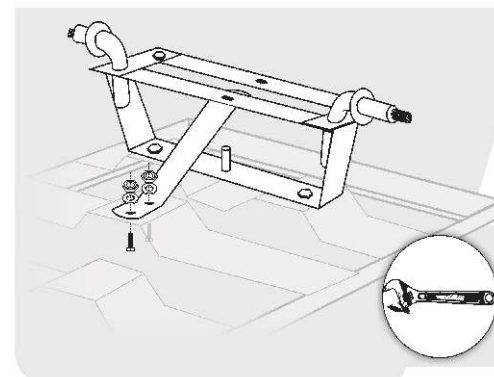

9. Insérez le bras coudé du stabilisateur d'essieu central dans le cylindre saillant du support d'essieu avant

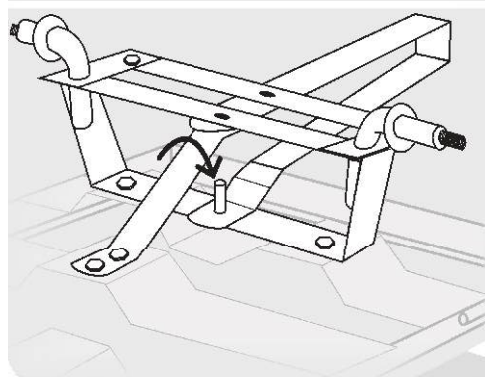

10. Positionnez le bras rectiligne avec le stabilisateur de l'essieu central entre le joint de direction et le support d'essieu avant

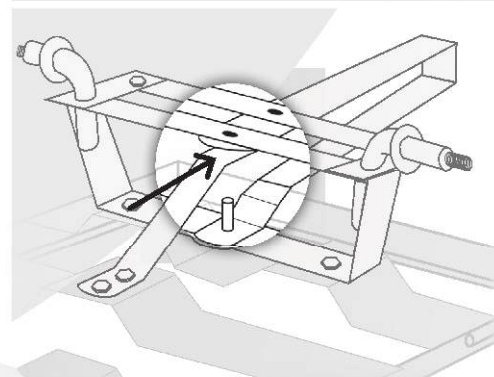

11. Fixez le stabilisateur de direction et le stabilisateur d'essieu central au support d'essieu avant en utilisant le boulon numéro 16

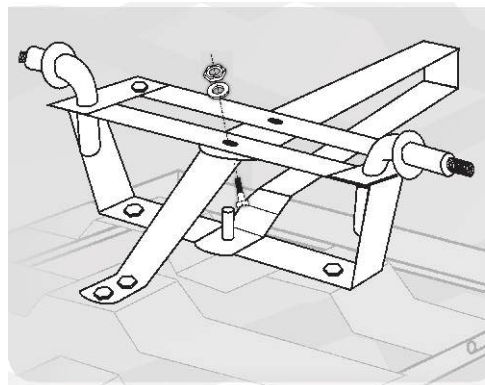

12. Fixez le stabilisateur d'essieu central sur le joint de l'essieu avant en utilisant une vis numéro 23

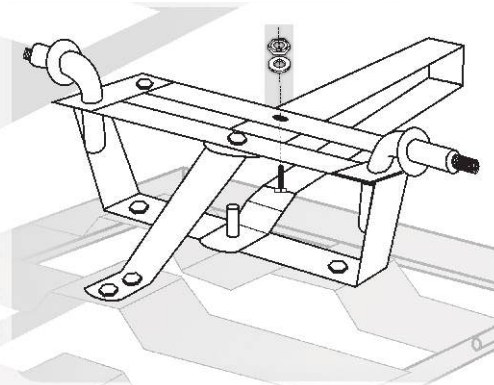



13. Poussez la goupille fendue 21 au travers du cylindre saillant sur le support d'essieu avant et sécurisez

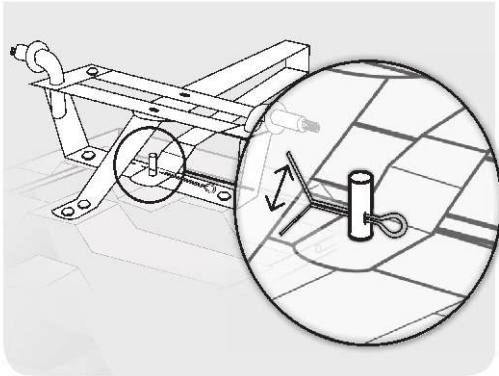

14. Attachez l'embout en forme de U de la barre de direction au stabilisateur d'essieu central en utilisant le boulon numéro 20

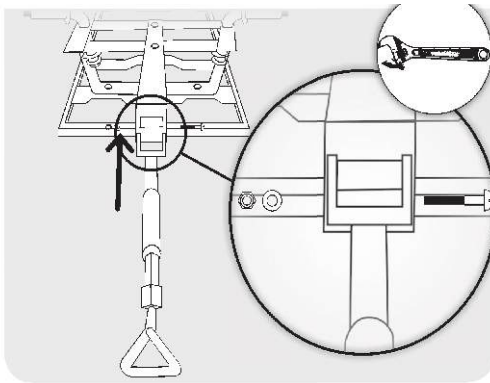

15. Fixez les 4 pneus aux supports d'essieu en utilisant 17/18 comme montré ci-dessous

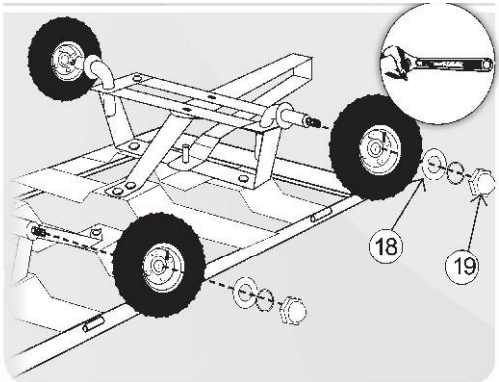

16. Tournez le chariot de manière à ce que les roues touchent le sol

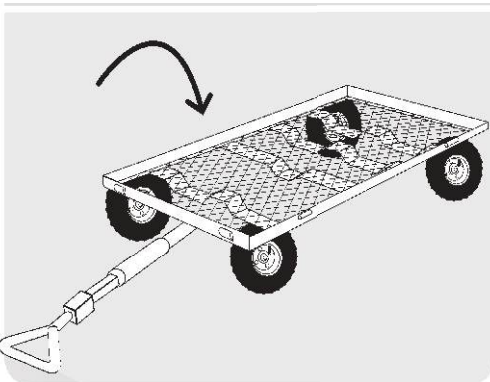

17. Fixez les panneaux avant, arrière et latéraux à la caisse en poussant les goupilles fendues 14 au travers des charnières placées sur le côté extérieur de chaque panneau et de la caisse. Répétez la procédure pour chaque panneau, 2 de chaque côté.

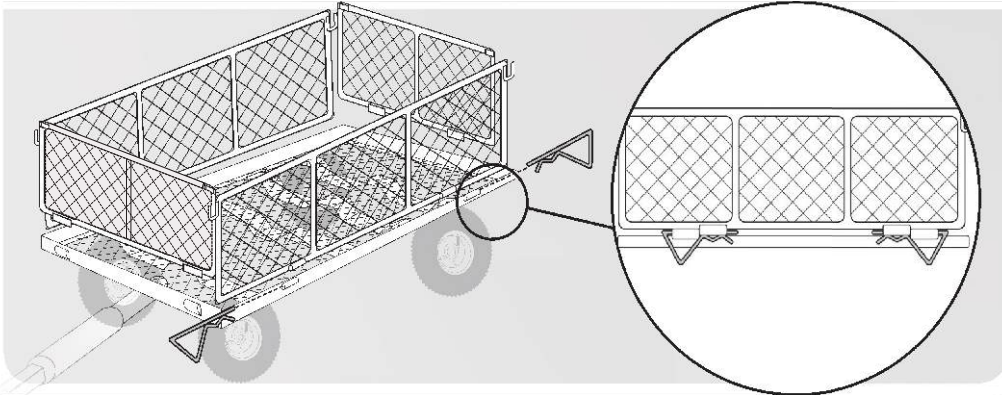

18. Pour maintenir le cadre en place, accrochez les poignées de verrouillage 22 aux charnières en forme de U soudées sur les parties supérieures des panneaux latéraux comme montré ci-dessous

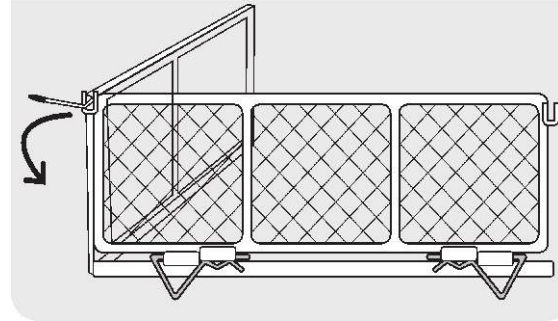

19. Placez le revêtement en plastique ultra-robuste à l'intérieur du chariot et fixez-le au moyen des boutons-pression.

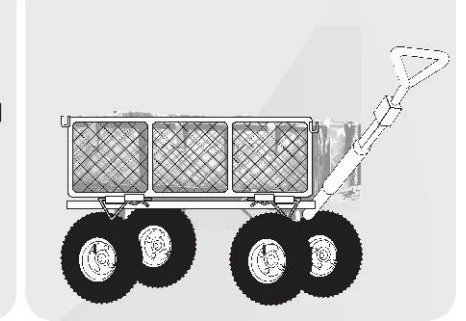

## Diagramme de montage

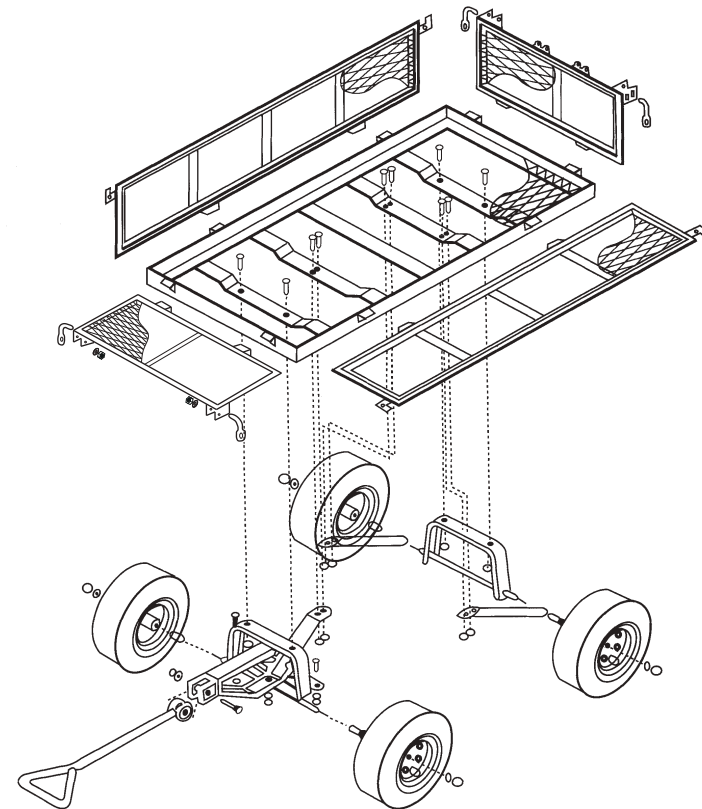

## LISTADO DE PIEZAS

### PIEZAS DE LA ESTRUCTURA PRINCIPAL

- 1.TH123-1  
Estructura principal  
(1 pza.)
- 2.TH123-2  
Panel lateral  
(2 pzs.)
- 3.TH123-3  
Panel frontal  
(1 pza.)
- 4.TH123-4  
Panel trasero  
(1 pza.)
- 5.TH123-5  
10\*350-4 Neumáticos  
(4 pzs.)

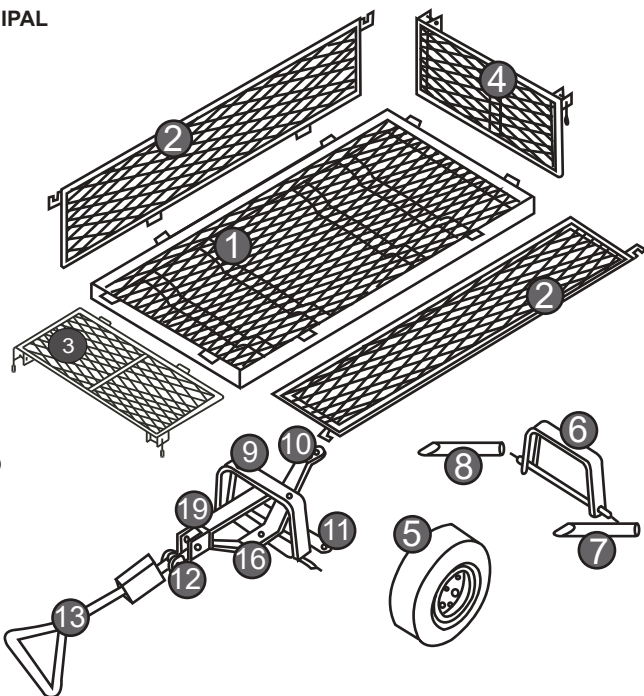

### MONTAJE DEL SOPORTE TRASERO

- 6.TH123-6  
Soporte del eje trasero  
(1 pza.)
- 7.TH123-7  
Fijación izquierda del eje trasero  
(1 pza.)
- 8.TH123-8  
Fijación derecha del eje trasero  
(1 pza.)

### MONTAJE DEL SOPORTE FRONTAL

- 9.TH123-9  
Soporte del eje delantero  
(1 pza.)
- 10.TH123-10  
Fijación central del eje delantero  
(1 pza.)
- 11.TH123-11  
Pieza de unión entre el sistema de dirección y el enganche para remolque  
(1 pza.)
- 12.TH122-12  
Pieza de unión del sistema de dirección  
(1 pza.)
- 13.TH122-13  
Mango  
(1 pza.)
- 14.TH123-14  
Pasador beta para los paneles laterales  
(8 pzs.)

- 15.TH123-15  
Tornillo 8\*16mm + tuerca + arandela plana  
(10 pzs.)

### MONTAJE DE LA ESTRUCTURA

- 16.TH123-16 Tornillo para eje de dirección 6\*20mm (1 pza.)



- 17.TH122-17 Tuerca 12mm (4 pzs.)



- 18.TH122-18 Arandela plana 12mm (4 pzs.)



- 19.TH123-19 Eje de dirección (1 pza.)



- 20.TH123-20 Tornillo para el montaje del enganche del remolque 8\*60mm (1 pza.)



- 21.TH123-21 Pasador partido para eje de dirección 4.5mm (1 pza.)



- 22.TH123-22 Palanca de seguridad para el panel lateral izquierdo (2 pzs.) + palanca de seguridad para el panel lateral derecho (2 pzs.)



- 23.TH123-23 Tornillo 6\*16mm (3 pzs.)



- 24.TH123-24 Funda (1 pza.)

- 25.TH123-25 Bandeja de rejilla (1 pza.)



ES

401418

# CARRITO DE TRANSPORTE CON BANDEJA MÁX. 550KG

MANUAL DE INSTRUCCIONES DE USO DEL FABRICANTE TRADUCIDO



CONSERVAR PARA SER LEÍDO POR CADA NUEVO USUARIO, ANTES DE UTILIZAR EL ARTÍCULO POR PRIMERA VEZ

TecTake GmbH,  
Tauberweg 41, D-97999 Igersheim, Germany

## MONTAJE

1. Coloque la estructura principal con la cara inferior hacia arriba.

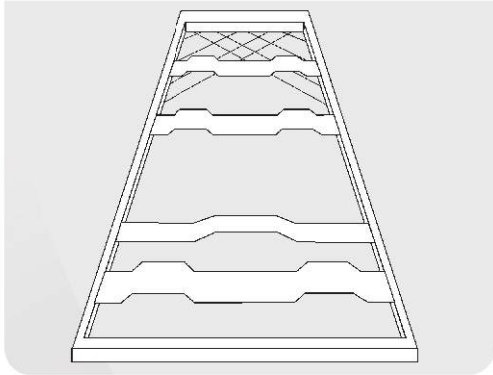

2. Fije el soporte del eje trasero a la estructura principal usando 2 piezas de la combinación 15 en el orden mostrado más abajo.

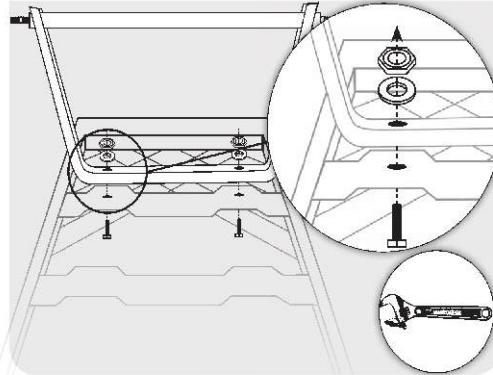

3. Monte las fijaciones en las barras del soporte del eje trasero.

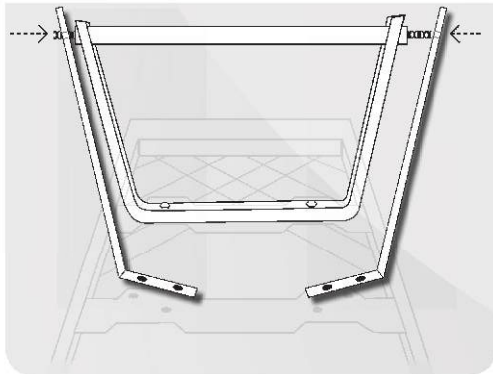

4. Fije las fijaciones a la estructura principal usando 4 piezas de la combinación 15.

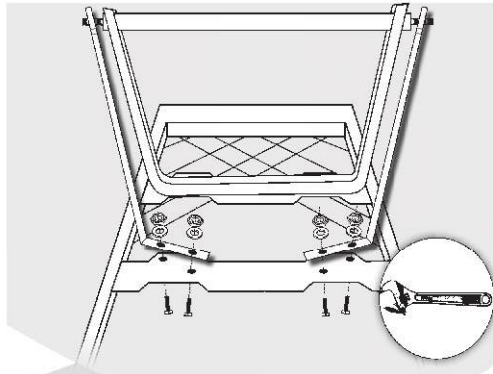

5. Fije el soporte del eje delantero a la estructura principal usando 2 piezas de la combinación 15 en el orden mostrado más abajo.

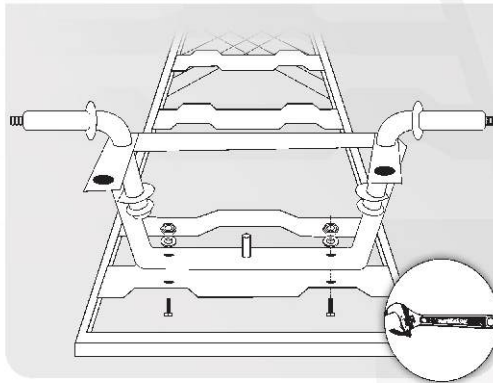

6. Fije la junta del eje delantero bajo los brazos del soporte del eje delantero usando 2 piezas de la combinación 23.

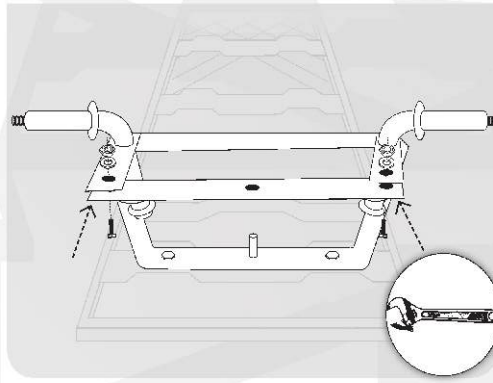

7. Coloque la fijación central entre el soporte del eje y la estructura principal tal y como se muestra en la imagen.

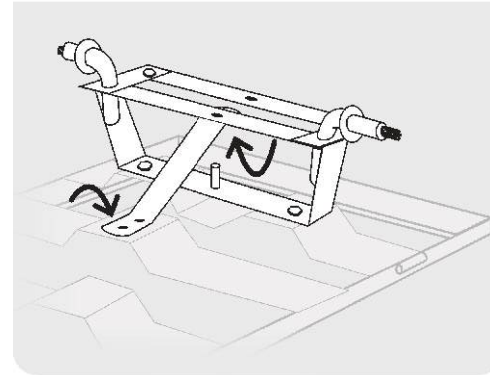

8. Fije la fijación central a la estructura principal usando 2 piezas de la combinación 15 tal como muestra la imagen.

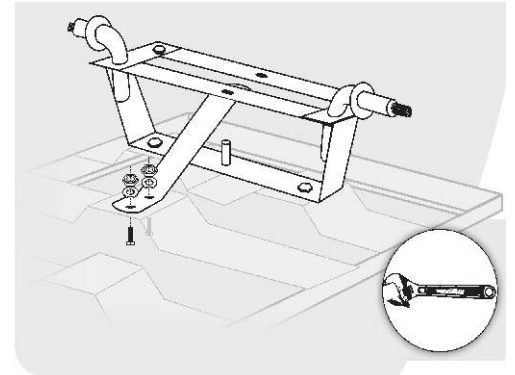

9. Introduzca el brazo escalonado del eje de dirección en el cilindro prominente del soporte del eje delantero.

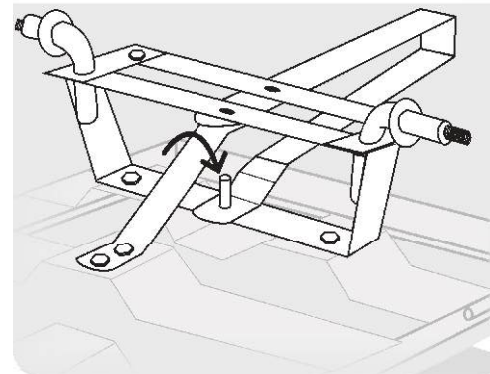

10. Coloque el brazo liso del eje de dirección entre la fijación central y el soporte del eje delantero.

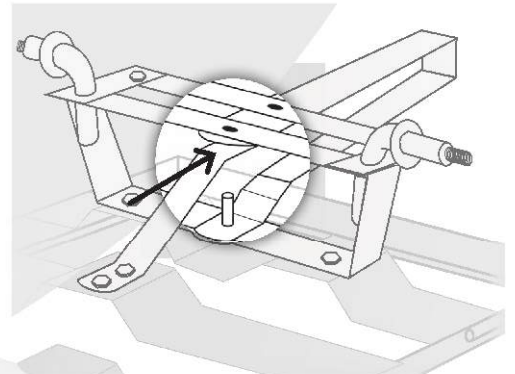

11. Fije la fijación central y el eje de dirección al soporte del eje delantero usando la combinación 16.

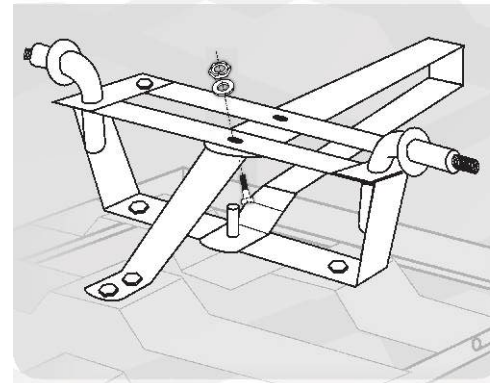

12. Fije el eje de dirección a la barra del soporte del eje delantero usando la combinación 23.

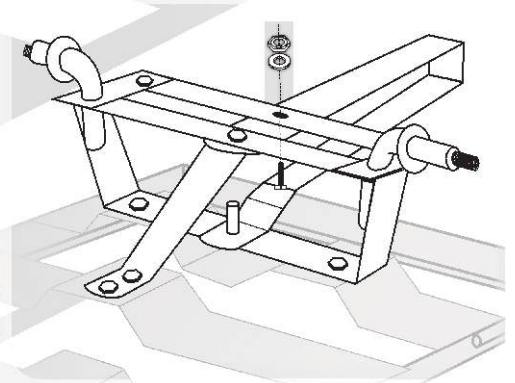

13. Introduzca el pasador partido (pieza 21) en el cilindro prominente del soporte del eje delantero y ábralo para asegurarlo.

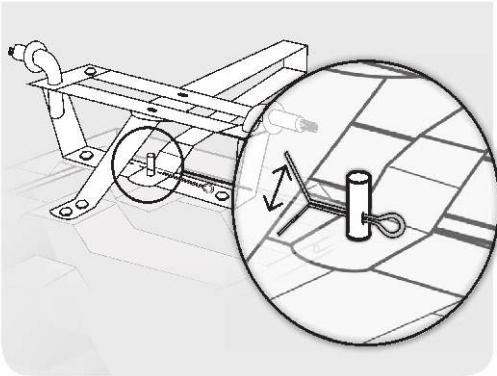

14. Enganche el extremo en forma de U del eje de dirección al mango con la pieza 20.

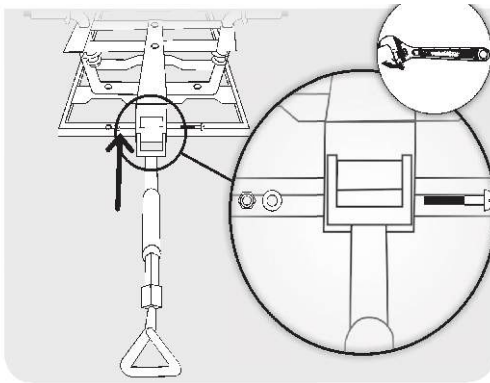

15. Inserte los 4 neumáticos en los soportes de los ejes usando las piezas 17 y 18 en cada una tal y como muestra la imagen.

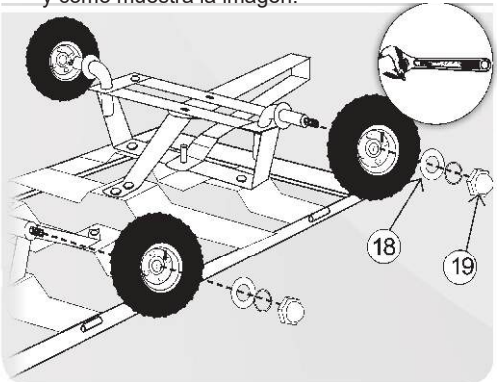

16. Dé la vuelta al carrito de transporte de manera que las ruedas toquen el suelo.

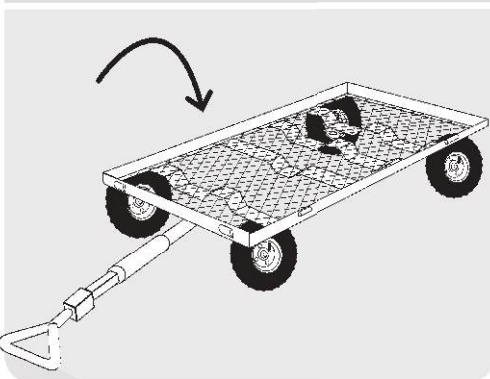

17. Enganche los paneles laterales, frontal y trasero a la estructura principal empujando los pasadores beta (pieza 14) a través de 2 bisagras de la parte exterior de cada panel y cada lado de la estructura principal. Haga esto con todos los paneles, colocando 2 pasadores por cada panel.

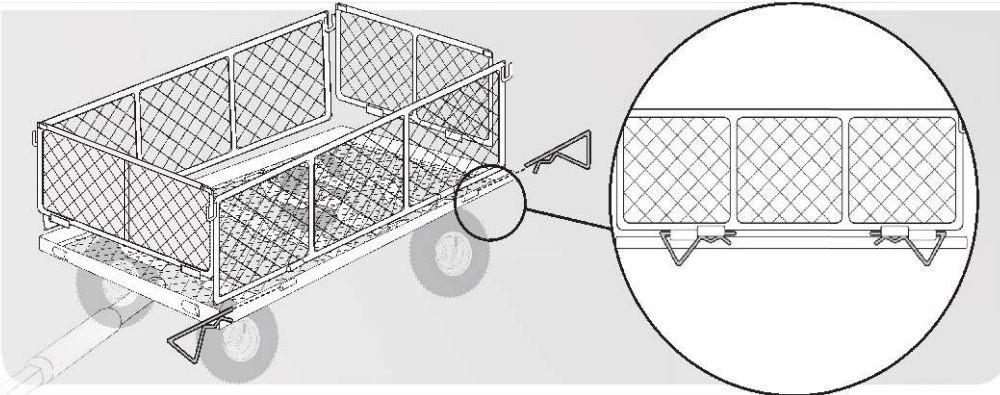

18. Para asegurar la estructura, enganche las palancas de seguridad (pieza 22) a través de las bisagras en forma de U soldadas en la parte superior de los paneles laterales, tal como se ve en la imagen.

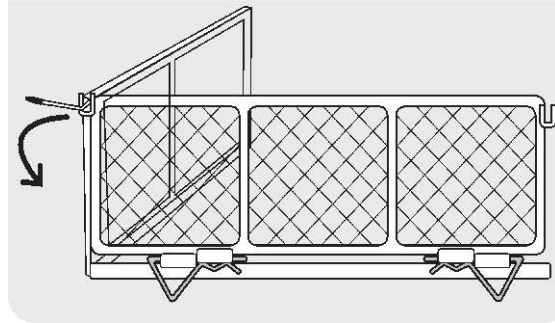

19. Coloque la funda interior en el interior del carrito de transporte y asegúrela con los botones de presión.

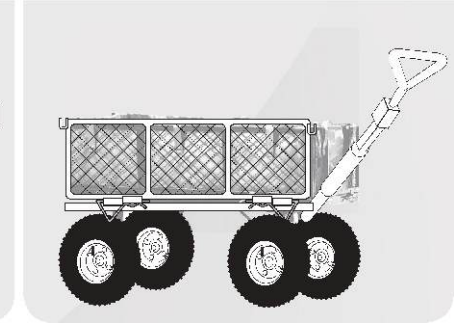

## DIAGRAMA DE MONTAJE

