

3 | Fernbedienung anlernen/ teach remote control

Siehe Q-Fernbedienungsanleitung
See Q-remote control manual

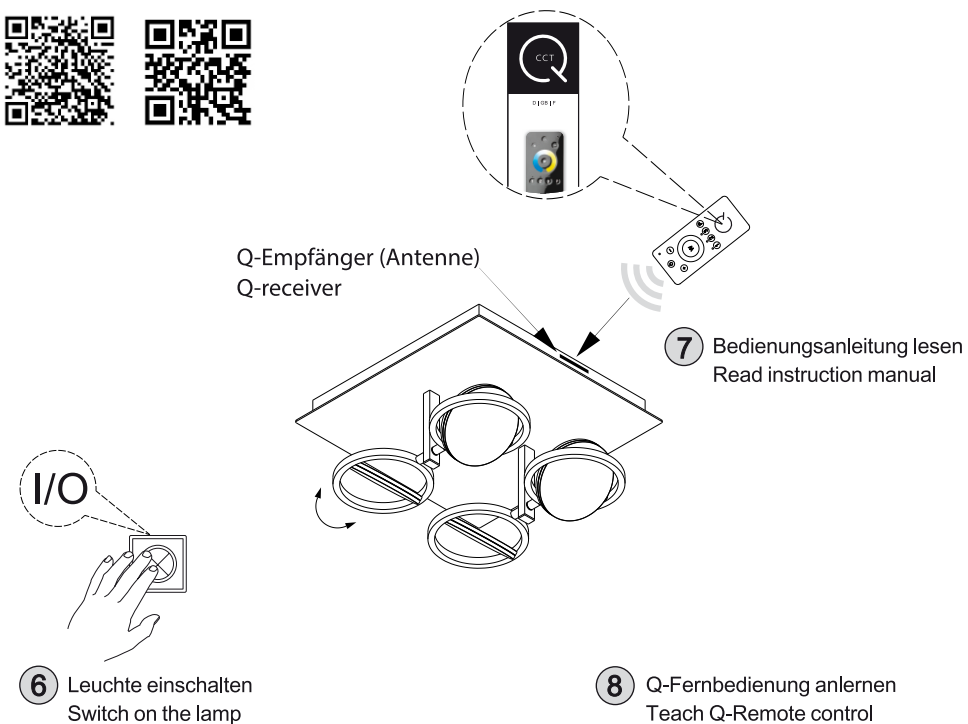

⚠ Reset

Rückstellen der Leuchte auf Werkseinstellung
Reset the lamp, factory new

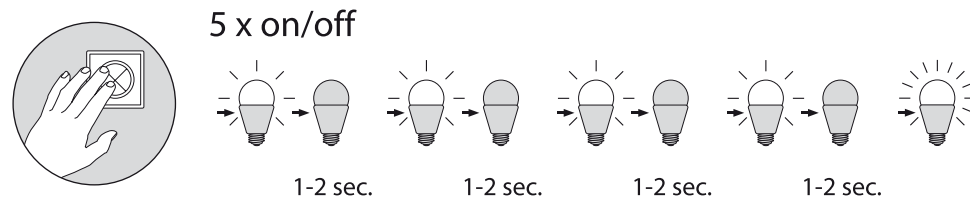

Das Gerät erfüllt die grundlegenden Anforderungen der Richtlinie 2014/53/EU (Radio Equipment Directive) des Europäischen Parlaments und des Rates der europäischen Union vom 16.04.2014 über Funkanlagen und die gegenseitige Anerkennung ihrer Konformität.
Die vollständige Konformitätserklärung kann bei der unten stehenden Adresse angefordert werden

This device fulfils the fundamental requirements of Directive 2014/53/EU (Radio Equipment Directive) of the European Parliament and of the Council of the European Union dated 16.04.2014 on items of radio equipment and the mutual recognition of their conformity.
The full declaration of conformity can be requested from the address given below.

Paul Neuhaus

Paul Neuhaus GmbH
Olakenweg 36 · D-59457 Werl

Telefon: +49 (0) 29 22-97 21-0
Telefax: +49 (0) 29 22-97 21-9120
E-mail: info@neuhaus-group.de
www.neuhaus-group.de



829087

230V / 50 Hz
4 x 4,2W LED-Board
nicht wechselbar / not changeable

LED	4,2 W
	500 lm
t	20 W
T _k	1.400 lm
	25.000 h
	2.700-5.000 K
	15.000 x
	<1 s
	dimmable with rrc

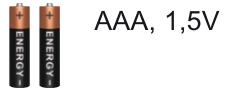
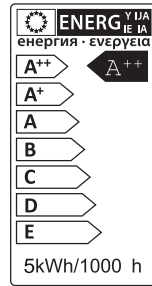

Inkl. Funkfernbedienung
Incl. radio remote control



1 | Montage / fitting

Als Deckenleuchte
As ceiling light

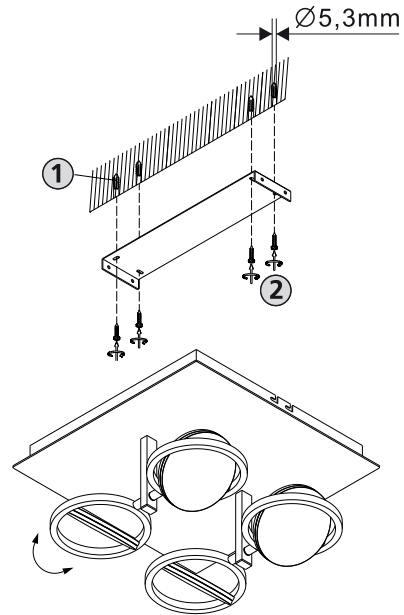

2 | Elektrischer Anschluss / electrical connection

230 Volt / 50Hz-Anschluss
230 Voltage / 50Hz connection

