

Modell: CITY / GIRON 24

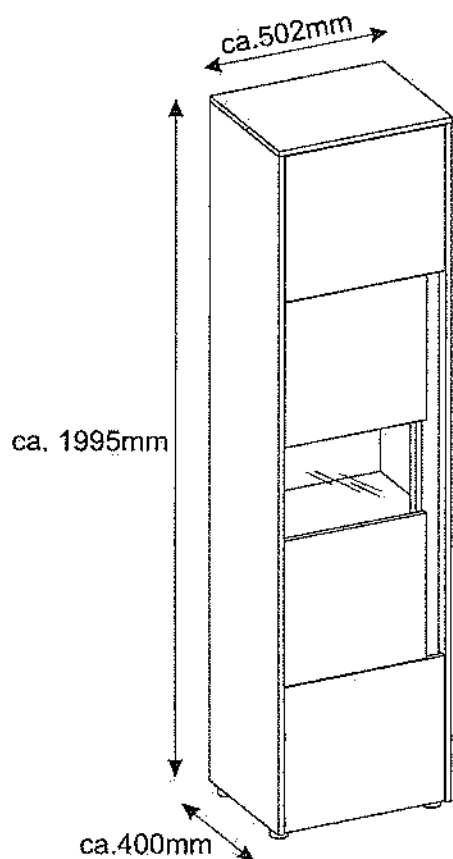

- Ⓛ Montagueanleitung
- ⓃL Handleiding voor de montage
- ⓂR Montaj talimatı
- ⓕ Notice de montage
- ⒸZ Montážní návod
- ⓂU Szerelési útmutató
- ⓖB Assembly Instructions
- ⓅL Instrukcja montażu
- ⓂU Инструкция по монтажу
- ⓂT Istruzioni di montaggio
- ⓂK Návod na montáž
- ⓂO Instrucțiunile de montaj
- ⓂS Instrucciones de montaje
- ⓂR Montaj Talimatı

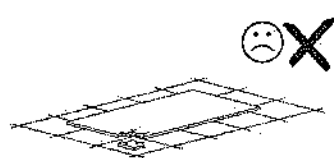

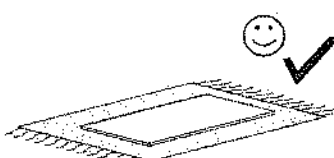
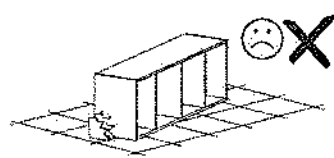
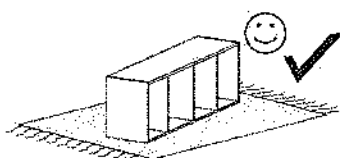
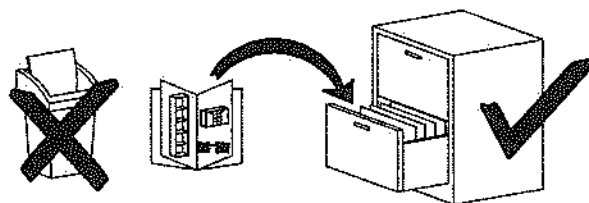
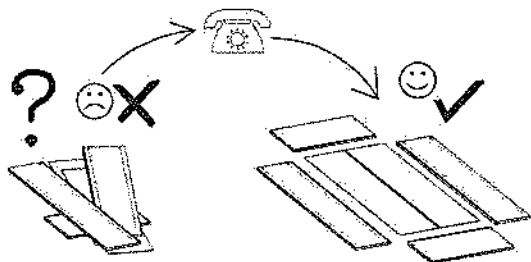
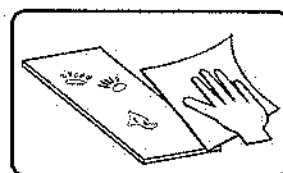
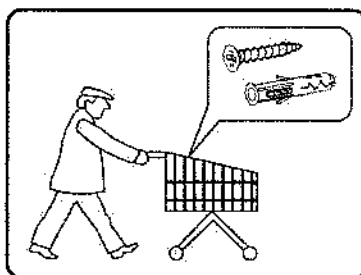
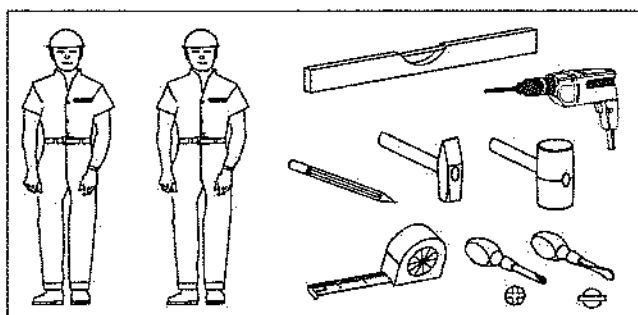
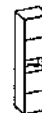



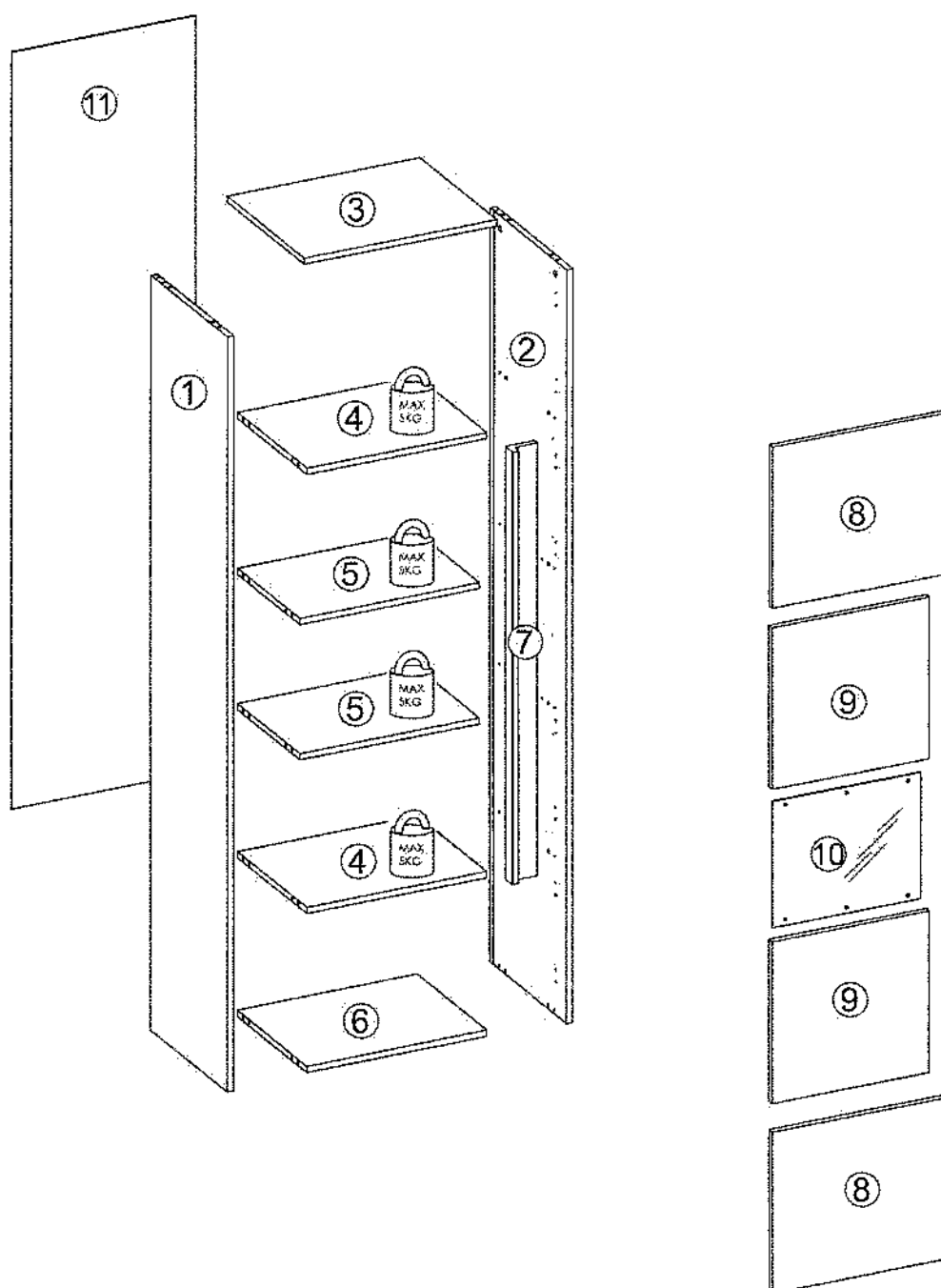

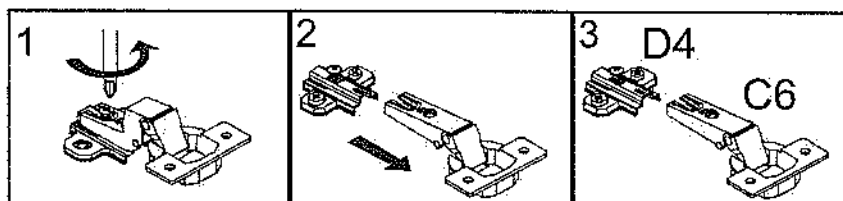
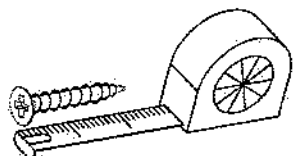
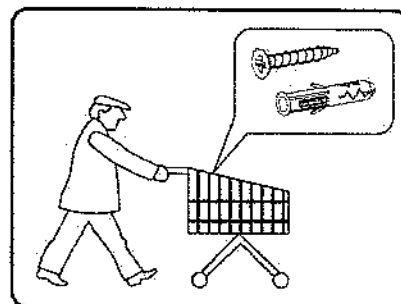
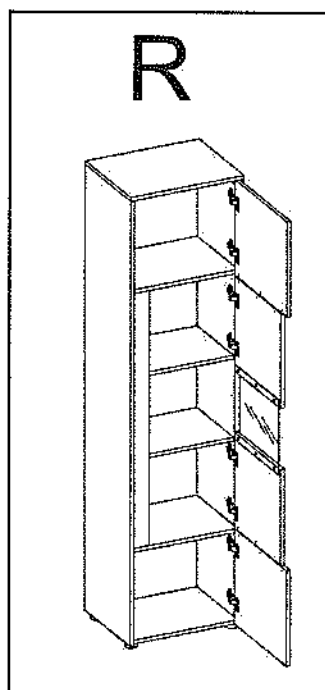
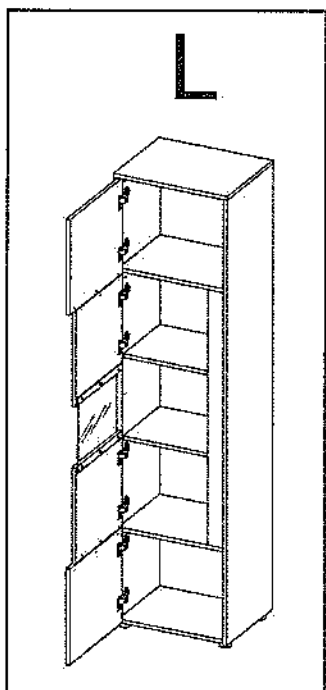
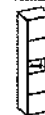







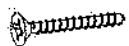

nr	L[mm]	B[mm]	f[mm]	Menge	Coli
1	1954	400	16	1	2/2
2	1954	400	16	1	2/2
3	502	401	16	1	1/2
4	468	362	16	2	2/2
5	468	325	16	2	2/2
6	468	362	16	1	1/2
7	1122	77	38	1	2/2
8	419	463	16	2	1/2
9	419	410	16	2	1/2
10	328	387	4	1	2/2
11	1963	478	3	1	2/2





B1  ø8x35 x24	I7  x20	K1  x24	K10  x24	D4  x8
C6  x8	G36  4x30 x4	G34  3,5x16 x17	G49  4x16 x16	F13  x5
I1  x9	M11  x1	G50  3x20 x12	P10  x4	F20  x6

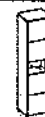

I

K10



x20

B1



ø8x35

x4

K1



x4

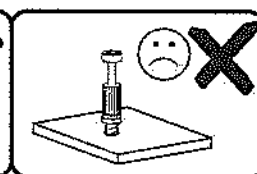
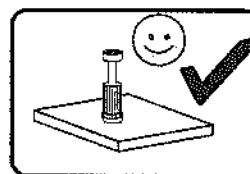
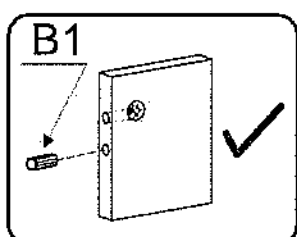
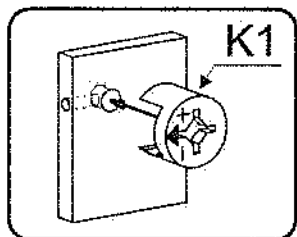
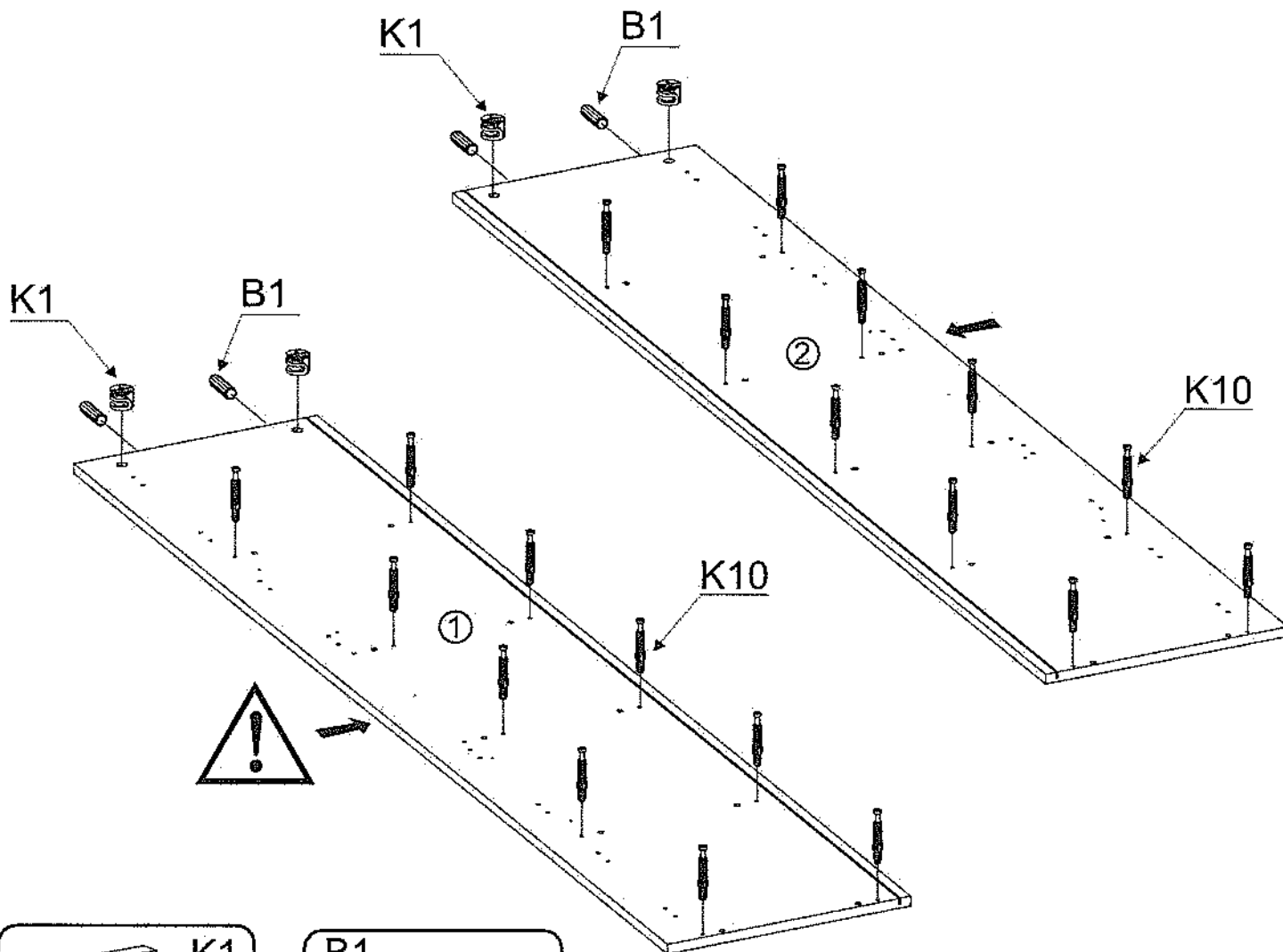

II

K10

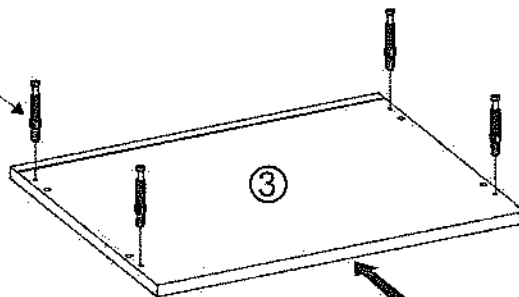

K10



x4

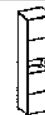

III

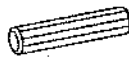
B1  $\varnothing 8 \times 35$ x20

K1  x20

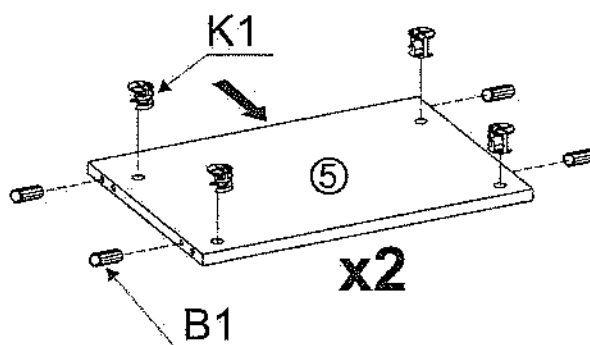
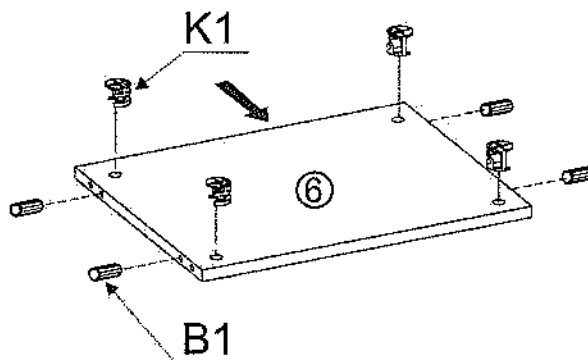
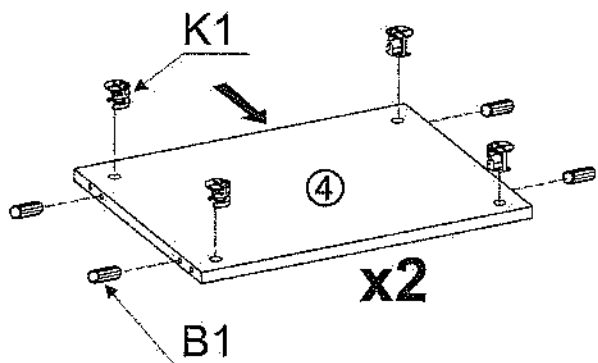

IV

F13  x5

G49  4x16 x5

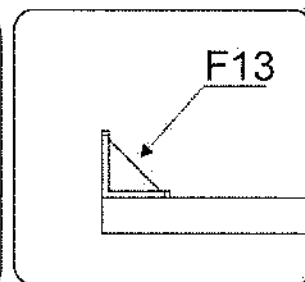
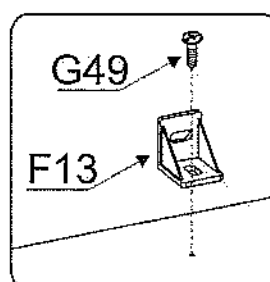
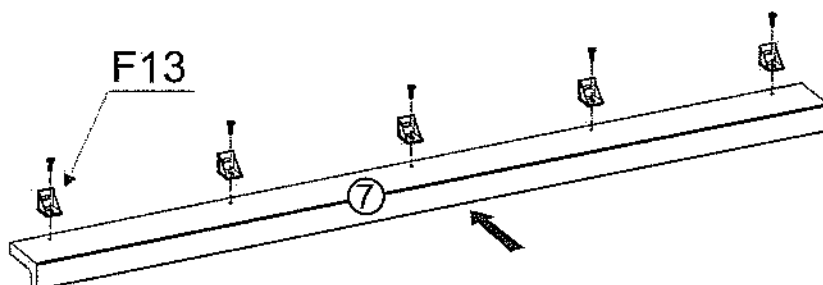



V

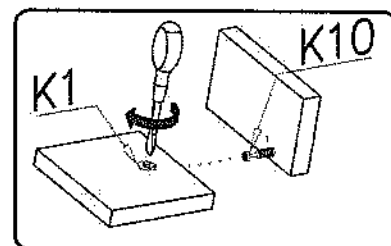
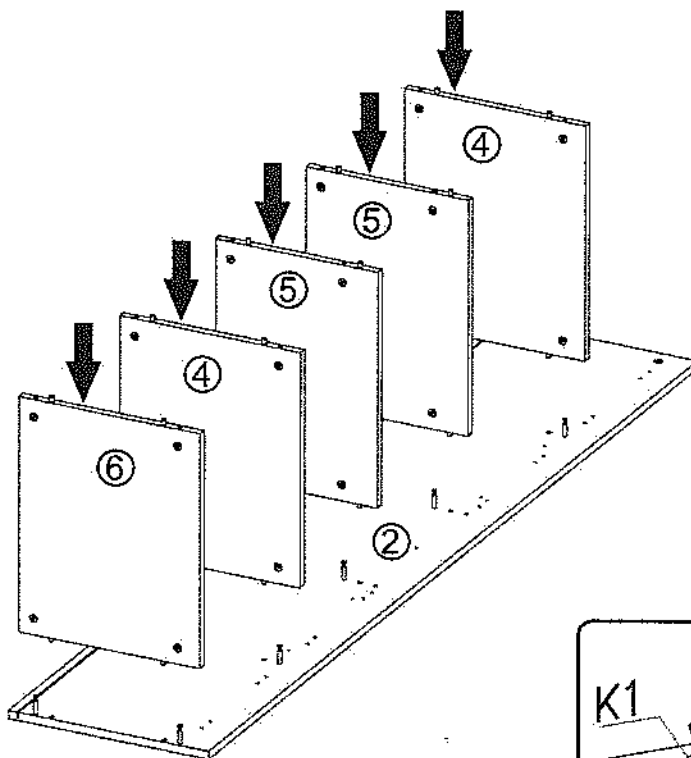
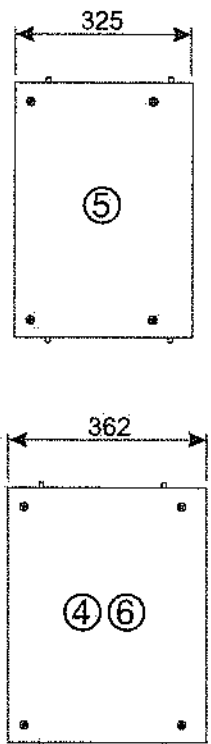

VI

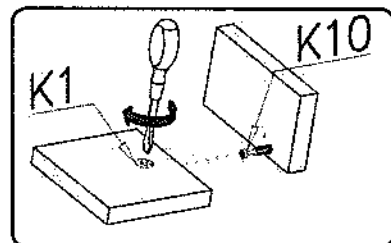
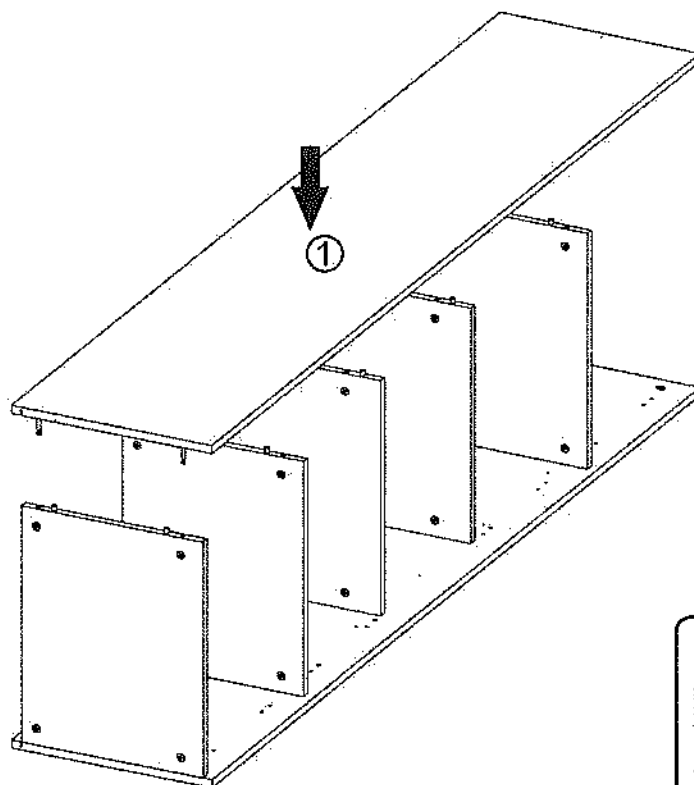



VII

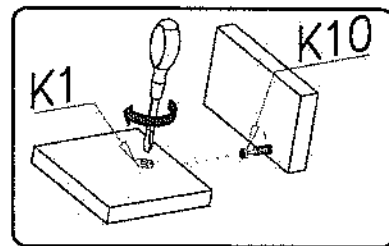
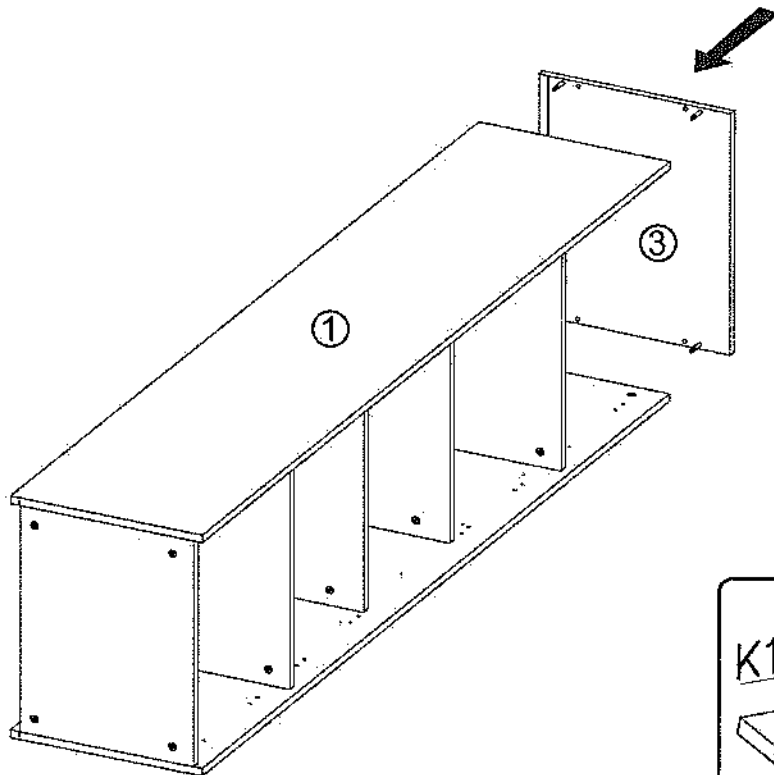

VIII

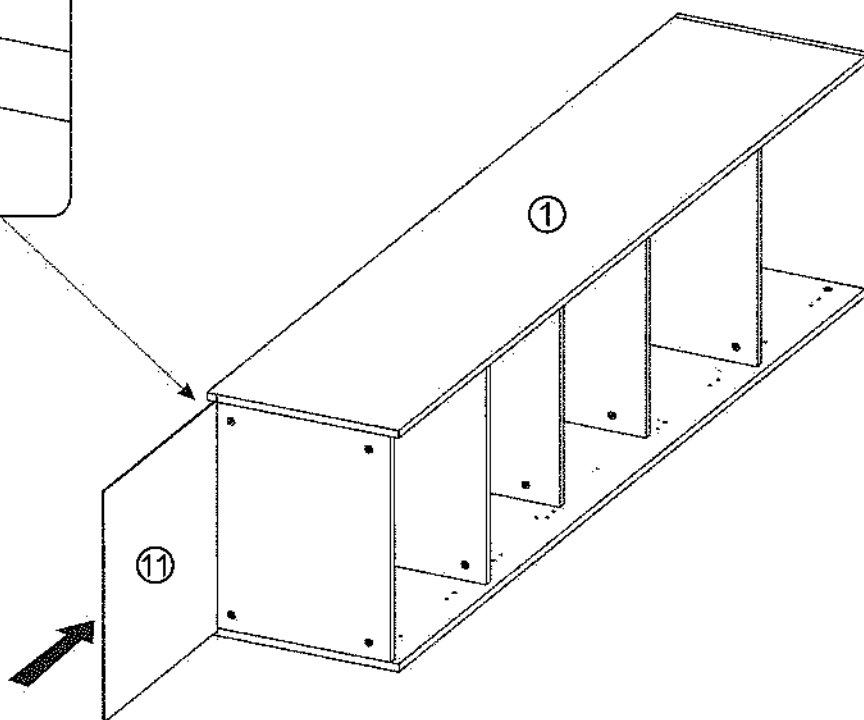
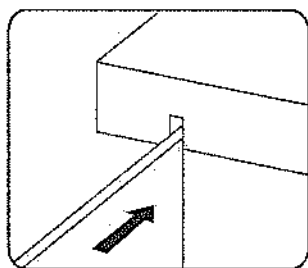



IX

G50



3x20

x12

I1



x9

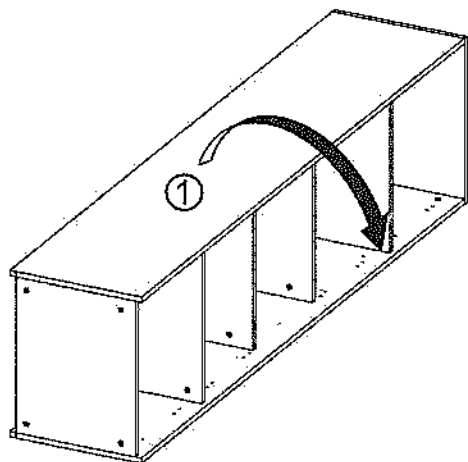

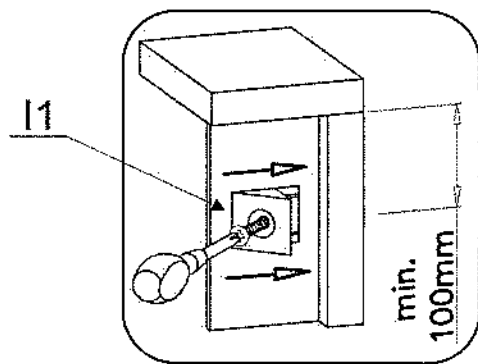
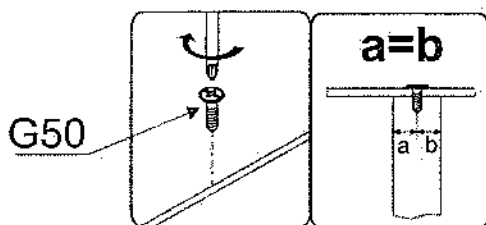
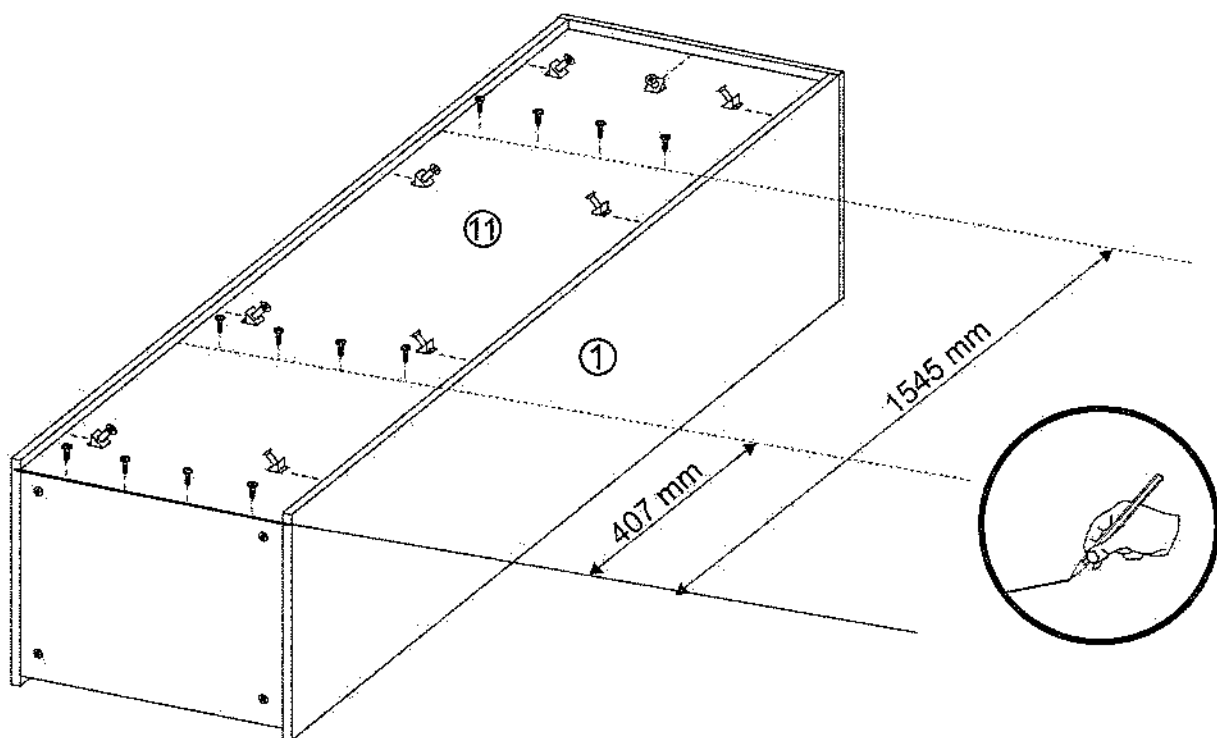
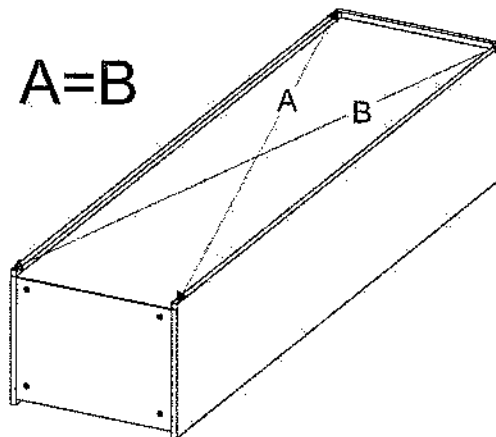

A=B



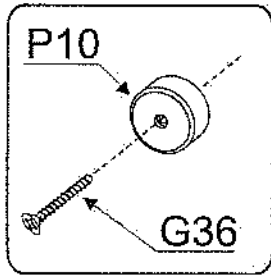

X

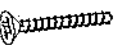

- P10  x4
- G36  4x30 x4

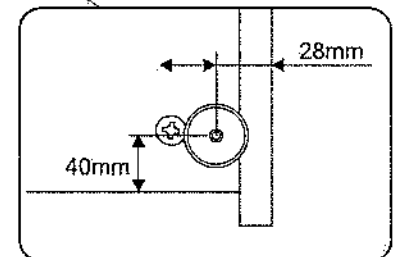
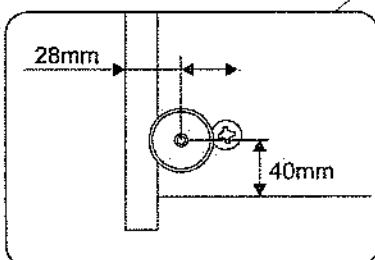
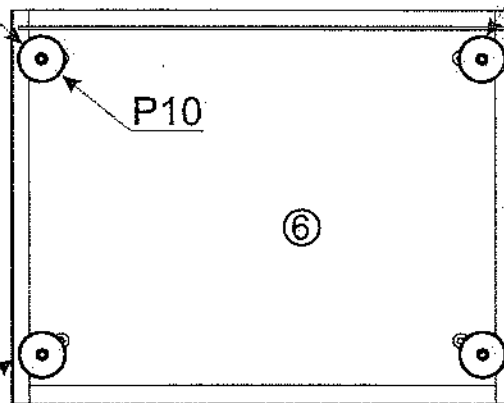
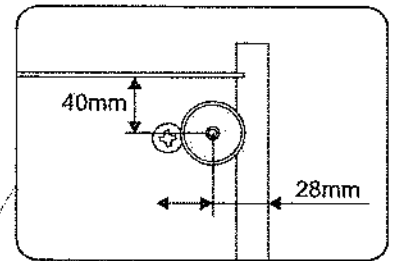
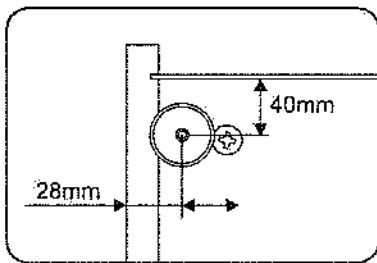
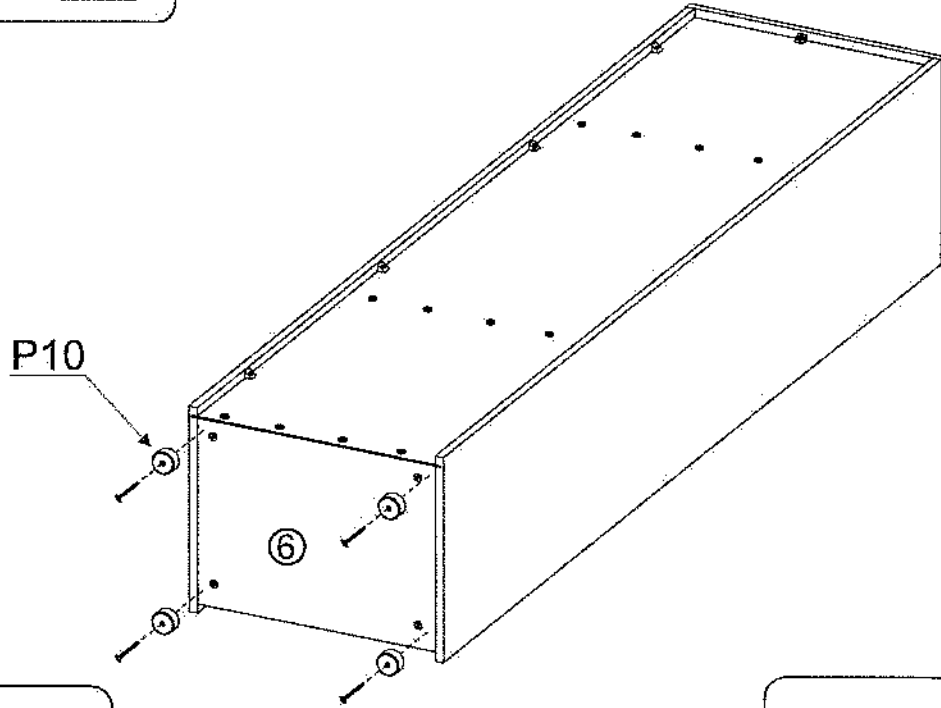



XI

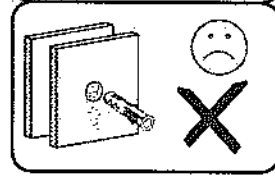
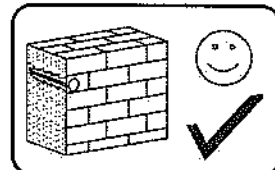
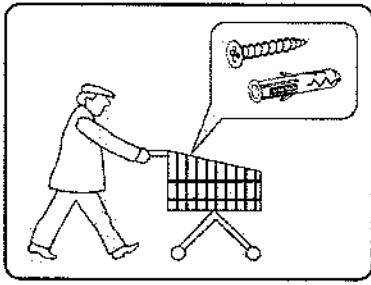

G34



3,5x16

x1

M11



x1

I7



x20

M11

M11

G34

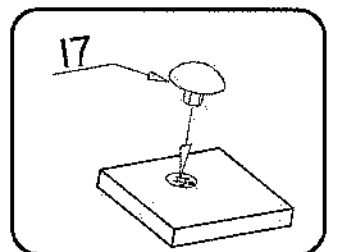
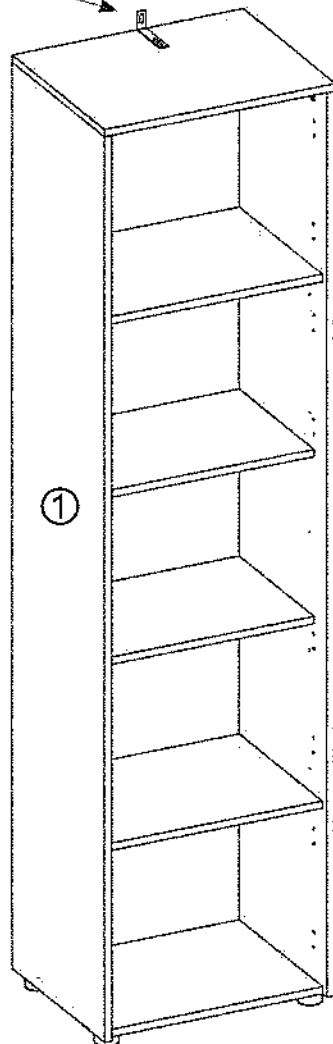
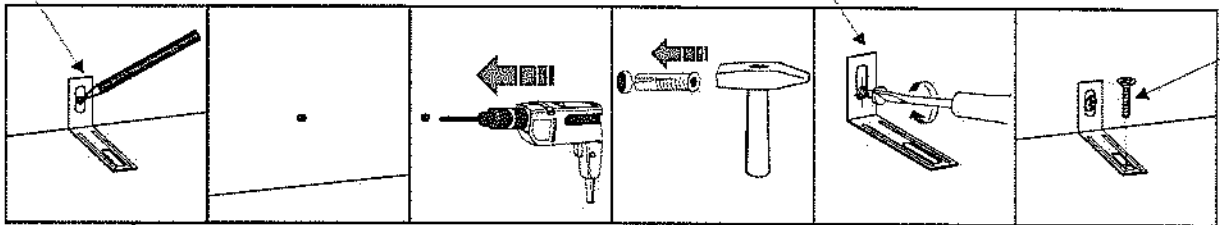

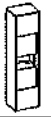

XII

F20



x6

G49



4x16

x6

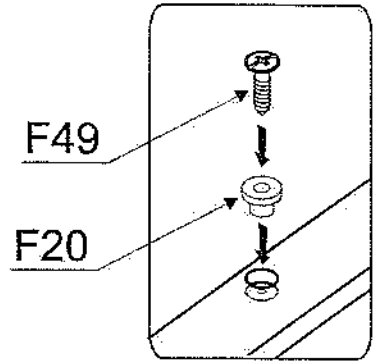
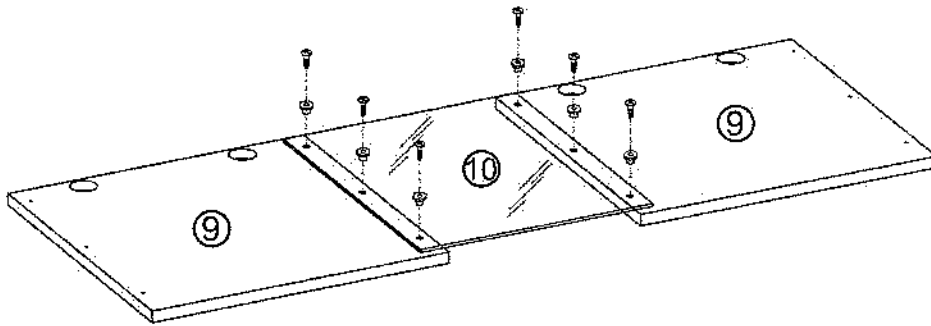

XIII

C6

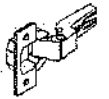

x8

G34



3,5x16

x16

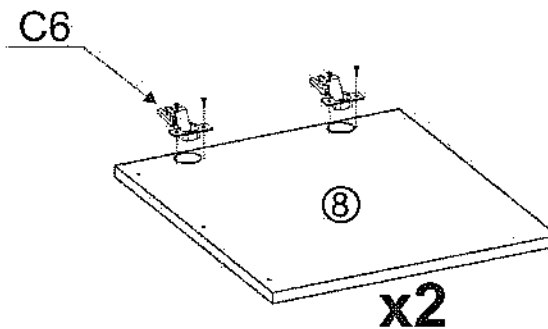
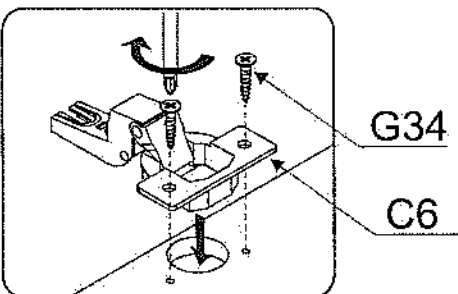
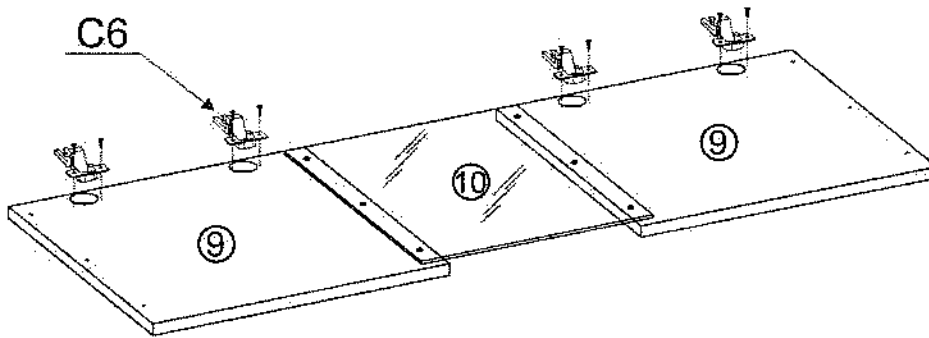

x2

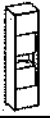

XIV

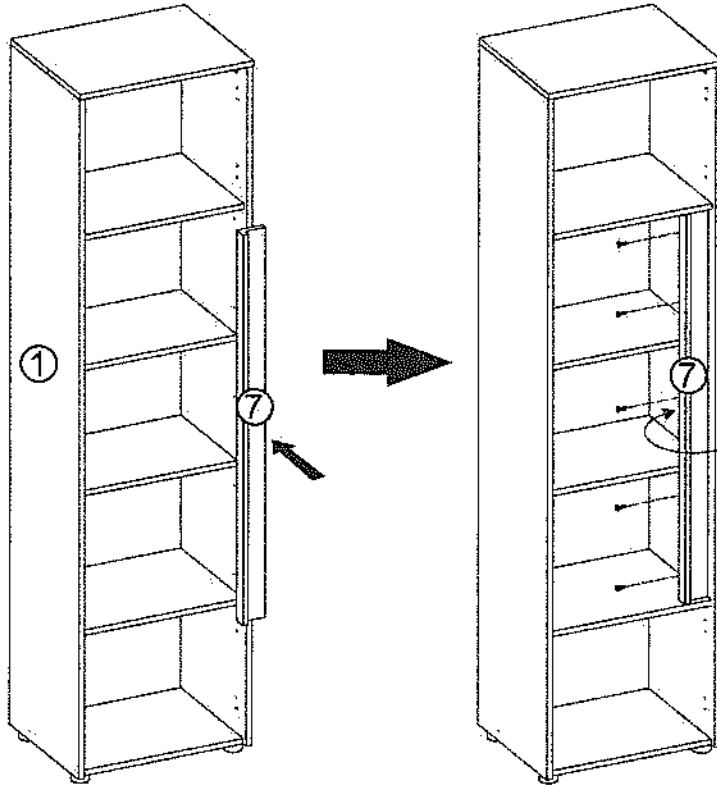
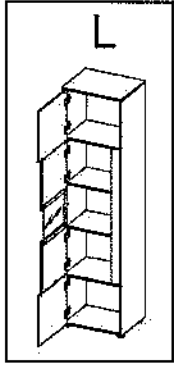

G49



4x16

x5

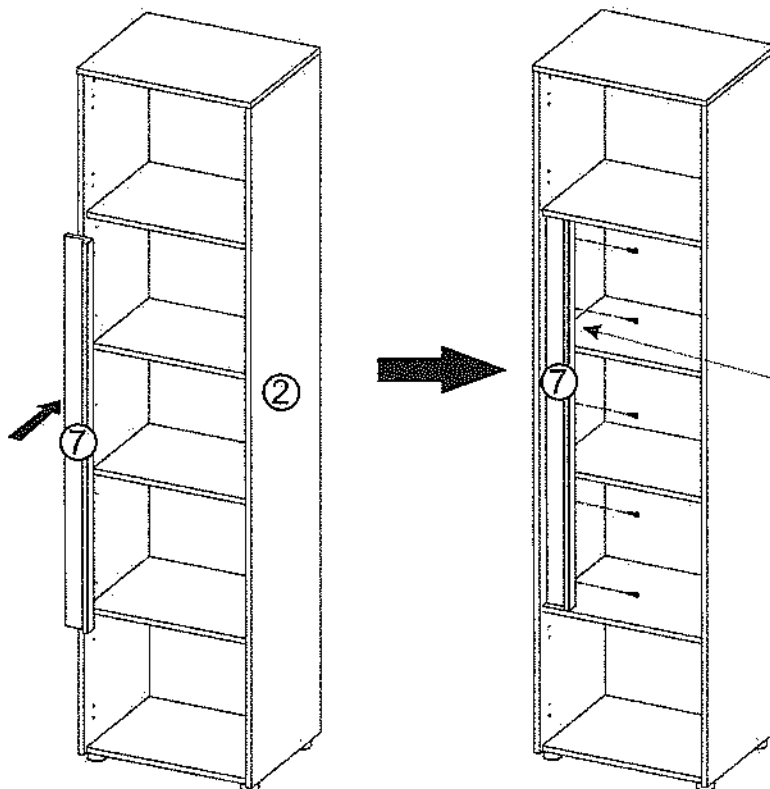
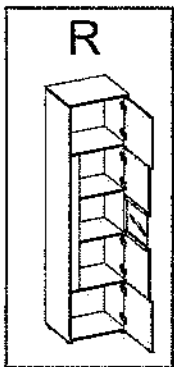
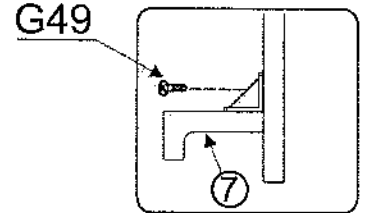
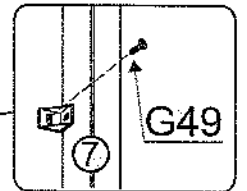

G49



4x16

x5

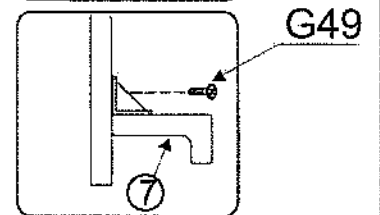
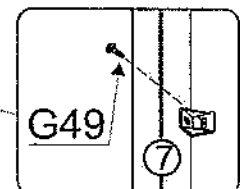

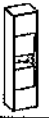

XV

D4



x8

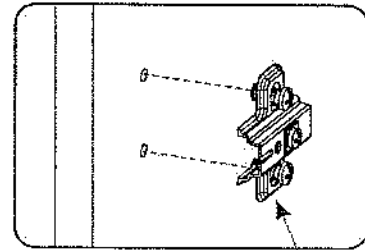
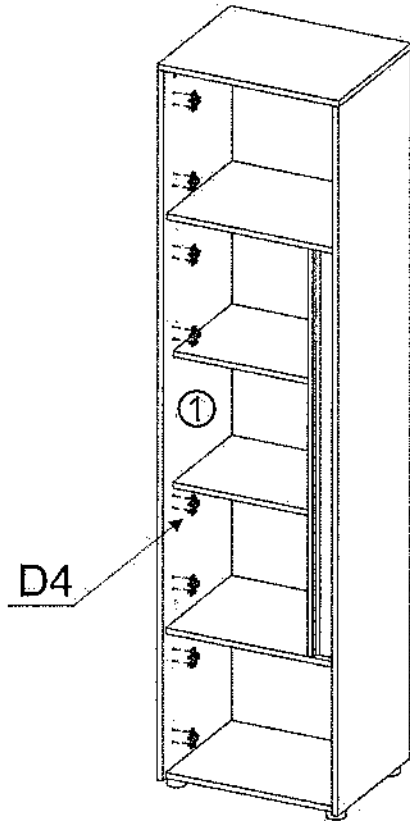
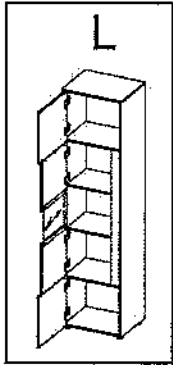

D4

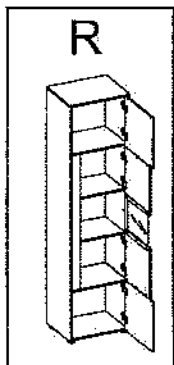

D4



x8

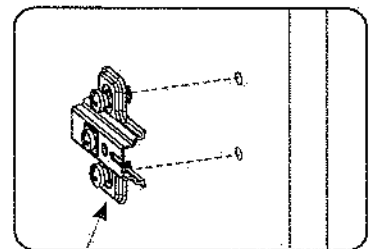
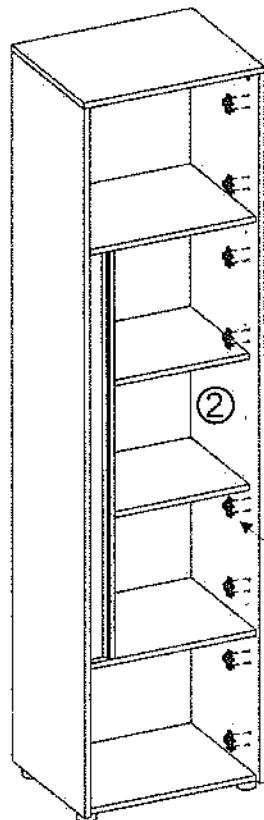

D4



XVI

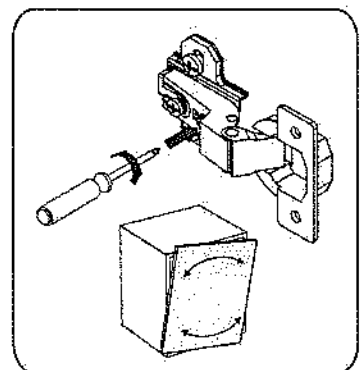
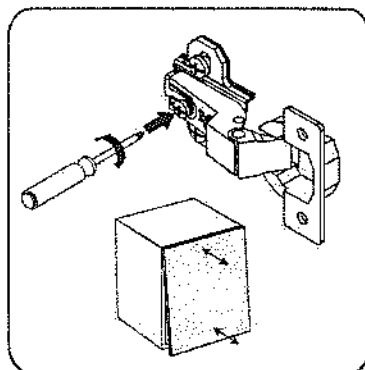
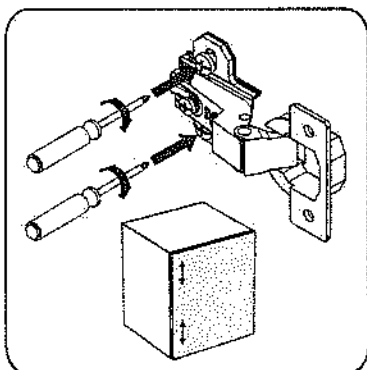
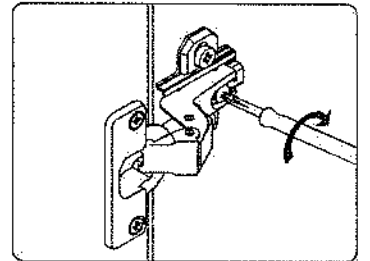
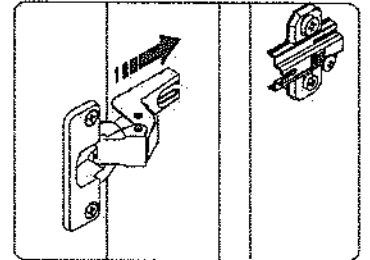
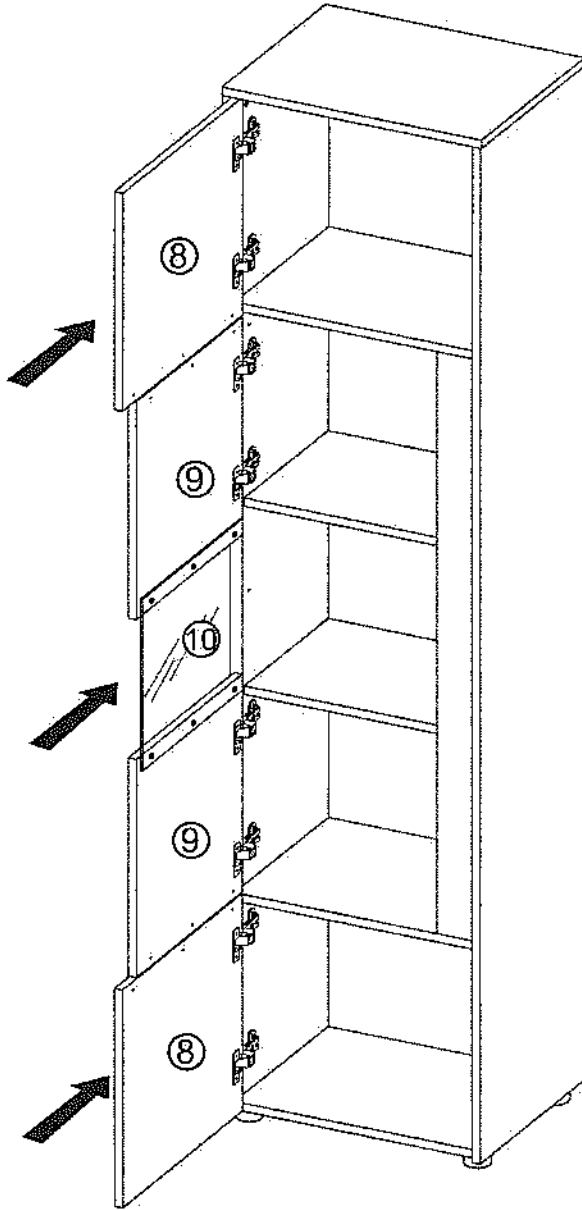
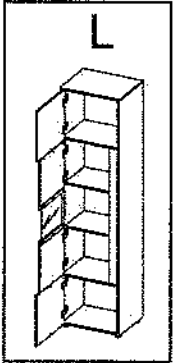

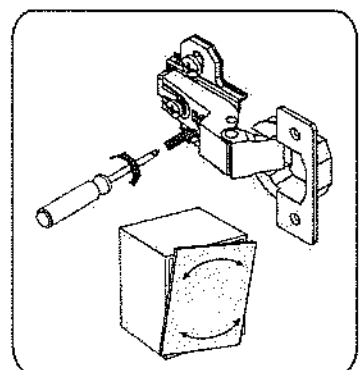
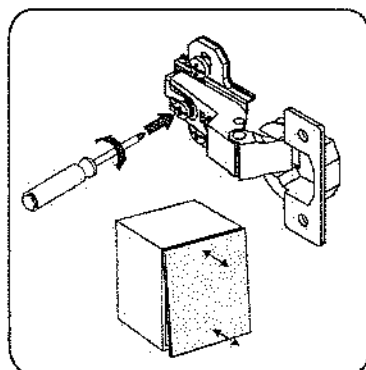
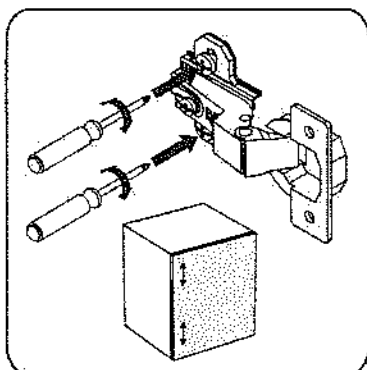
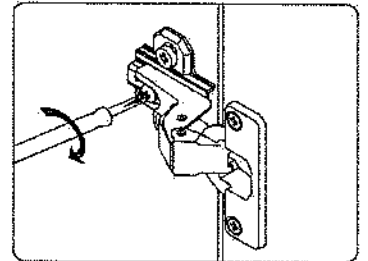
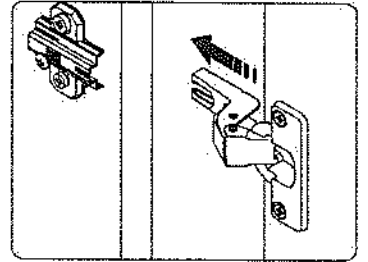
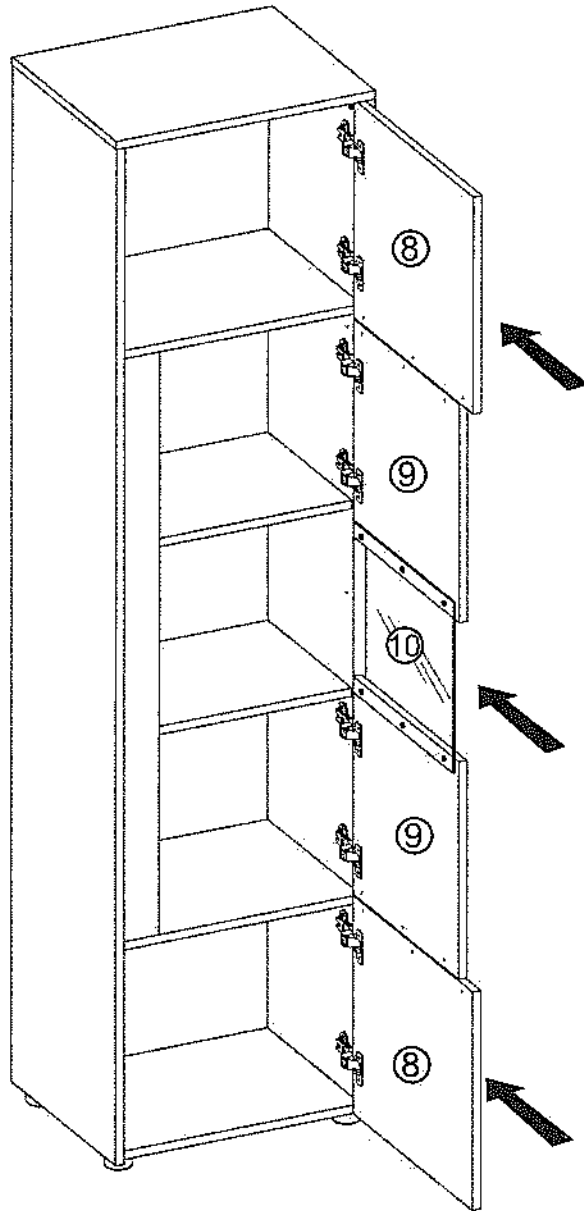
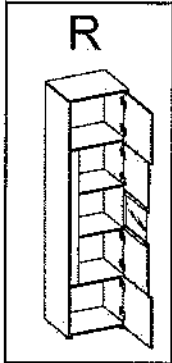

Name • Nom • Nome • Naam • Nazwa • Jméno • Názov • Név • Denumire • Isim • Имя
 CITY / GIRON — 24

D Unser Direktservice für Beschädigte
 Sollte Ihnen ein Beschädigtes fehlen, können Sie diese Servicekarte direkt an die untenstehende Adresse mailen. Wir können allerdings nur Beschädigte auf diesem Wege verschicken. Sollten Sie eine andere Beanstandung an Ihrem Möbelstück haben, so wenden sie sich bitte direkt an Ihr Möbelhaus.

GB Our direct order service for fitting
 If a fitting part is missing, you can e-mail this service card directly to the address below. However, we can only send fitting parts in this way. If you have any other cause for complaint concerning your item of furniture, please contact your furniture store directly.

CZ Naše přímé služby pro kování
 Chybí-li vám nějaký díl z kování, můžete tuto servisní kartu odeslat e-mailem přímo na níže uvedenou adresu. Touto cestou však můžeme rozšířit jen díly kování. Pokud byste reklamovali jiný díl nábytku, obraťte se přímo na svého prodejce nábytku.

F Bien étudier la notice de montage
 Si l vous manque une ferrure, veuillez envoyer directement la présente carte service à l'adresse e-mail indiquée ci-dessous. Cependant, ceci nous permet uniquement d'envoyer des ferrures. Pour tout autre type de réclamation concernant votre meuble, veuillez contacter directement votre magasin d'ameublement.

I Il nostro servizio diretto per l'ordine della ferramenta
 Qualora Vi dovessero mancare un pezzo di fissaggio, allora Vi preghiamo di inviare questa carta di servizio immediatamente all'indirizzo sottostante. Possiamo inviare i pezzi di fissaggio solamente per mezzo di questo procedimento. Qualora dovreste avere qualche altra reclamazione in merito al mobile, allora Vi preghiamo di rivolgerVi direttamente al Vostro Negozio di mobili.

BG Нащата директна услуга за обкова
 Ако липсват части от комплекта, попълнете настоящата сервисна карта и ни я изпратете на e-mail адреса, посочен по-долу. По този начин можем да доставяме само липсващи елементи от обкова. Ако установите други дефекти по мебелите, Ви съветваме да се обърнете към мебелната къща/магазин, от който сте закупили стоката.

NL Onze directservice voor losse onderdelen
 Wanneer er een onderdeel ontbreekt, kunt u deze servicekaart direct aan onderstaand e-mailadres sturen. Wij kunnen langs deze weg echter alleen beslagdelen versturen. Mocht u een ander probleem aan uw meubel hebben, verzoeken wij u contact op te nemen met uw meubeldealer.

PL Nasz bezpośredni serwis części montażowych
 Jeżeli brakuje części koniecznych do montażu, prosimy o przesłanie nam niniejszej karty serwisowej na niżej podany adres e-mailowy. W ten sposób możemy przesyłać Państwu tylko brakujące części. W przypadku innych reklamacji dotyczących mebla, prosimy zgłosić się do salonu meblowego, w którym został dokonany zakup.

HR Servis za okove
 U slučaju da nedostaje neki od dijelova molimo vas da na dolje navedenu mail adresu pošaljete ovaj servisni obrazac. Na ovaj način mogu se dostaviti samo okovi. U slučaju da imate dodatne prigovore vezane uz komad namještaja molimo vas da se obratite izvorno trgovini namještaja gdje je isti kupljen.

HU Direktszolgálatunk vasalatok esetén
 Ha hiányzik egy vasalat, ezt a kártyát közvetlenül elküldhet az alább található címre. Azonban csak vasalatokat tudunk így küldeni. Amennyiben másfajta reklamáció áll fenn bútordarabjait illetően, forduljon közvetlenül a boltjához.

SK Naše priamy servis pre časti kovania
 Ak by Vám chýbala nejaká časť kovania, môžete poslať túto servisnú kartu poslať e-mailom na nižšie uvedenú adresu. Dieľo kovania vieme poslať iba týmto spôsobom. Ak by ste mali inú reklamáciu ohľadom Vašho nábytku, obráťte sa priamo na Vašu predajňu nábytku.

SLO Naše direktno uslužbno storitvo za okovje
 Če vam manjka kakšno okovje, lahko to servisno kartico pošljete po e-pošti direktno na spodnji naslov. Po tej poti vam lahko pošljemo samo okovje. Če želite reklamirati kakšen drug del pohištva, se obrnite neposredno na vašo trgovino pohištva.

RO Serviciul nostru direct pentru feronerie
 In cazul in care va lipseste o piesa de feronerie puteti sa trimiteți direct acest card de service prin e-mail la adresa de mai jos. Noi nu putem expedia piesa de feronerie decât pe această cale. Dacă aveți o altă reclamație referitoare la piesa de mobilier, atunci vă rugăm să vă adresați direct la magazinul dvs. de mobilă.

RUS Наш прямой сервис для поставок фурнитуры
 Если окажется, что Вам не хватает того или иного элемента фурнитуры, Вы можете отравить сервисную карту по факсу непосредственно на нижеприведенный адрес электронной почты. Однако, таким образом мы можем пересылать лишь фурнитуру. Если же у Вас возникнут иные претензии относительно приобретенной мебели, пожалуйста, обращайтесь непосредственно в организацию, осуществлявшую продажу.

S Vår direktservice för beslagdelar
 Om du saknar eri beslagdel kan du skicka detta servicekort direkt till e-postadressen som anges nedan. Tänk på att detta är den enda möjligheten att skicka beslagdelar till dig. Om du vill reklamera din möbel av en annan anledning måste du kontakta ditt möbelhus direkt.

ES Nuestro servicio directo para accesorios
 Si le falta algún accesorio, puede enviar esta tarjeta de servicio directamente a la siguiente dirección. No obstante, por este método solo podemos enviar accesorios. Si tiene alguna otra objeción sobre su mueble, consulte directamente con su mueblería.

TR Donatınız için doğrudan servisimiz
 Bir donatınız eksikse bu servis kartını doğrudan aşağıda bulunan adrese doğrudan mail yazabilirsiniz. Sadece bu yolla donatılar gönderiliriz. Mobilyanızda başka şikayetleriniz varsa lütfen doğrudan mobilya satıcınıza danışın.

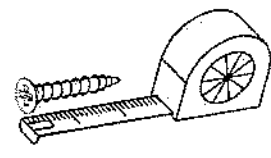

B1 ø8x35 X...	I7 X...	K1 X...
K10 X...	D4 X...	C6 X...
G36 4x30 X...	G34 3,5x16 X...	G49 4x16 X...
F13 X...	I1 X...	M11 X...
G50 3x20 X...	P10 X...	F20 X...

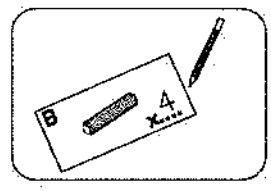

Name • Nom • Nome • Naam • Nazwa • Jméno
• Názov • Név • Denumire • Isim • Имя

Nr • No • N° • Номер • Č • Sz

Typ • Type • Tip • Тiрус • Тiро • Tun

CITY / GIRON

--

24

Unser Direktservice für Beschädigte

Sollte Ihnen ein Beschädigtes fehlen, können Sie diese Servicekarte direkt an die untenstehende Adresse mailen. Wir können allerdings nur Beschädigte auf diesem Wege verschicken. Sollten Sie eine andere Beanstandung an Ihrem Möbelstück haben, so wenden Sie sich bitte direkt an Ihr Möbelhaus.

Our direct order service for fitting

If a fitting part is missing, you can e-mail this service card directly to the address below. However, we can only send fitting parts in this way. If you have any other cause for complaint concerning your item of furniture, please contact your furniture store directly.

Naše ofimé služby pro kování

Chybí-li vám nějaký díl z kování, můžete tuto servisní kartu odeslat e-mailem přímo na níže uvedenou adresu. Touto cestou však můžeme zapsat jen díly kování. Pokud byste reklamovali jiný díl nábytku, obraťte se přímo na svého prodejce nábytku.

Bien servirier la notice de montage

Si vous manqué une ferrure, veuillez envoyer directement la présente carte service à l'adresse e-mail indiquée ci-dessous. Cependant, ceci nous permet uniquement d'envoyer des ferrures. Pour tout autre type de réclamation concernant votre meuble, veuillez contacter directement votre magasin d'aménagement.

Il nostro servizio diretto per l'ordine della ferramenta

Qualora Vi dovessè mancare un pezzo di fissaggio, allora Vi preghiamo di inviare questa carta di servizio immediatamente all'indirizzo sottostante. Possiamo inviare i pezzi di fissaggio solamente per mezzo di questo procedimento. Qualora dovessè avere qualche altra reclamazione in merito al mobile, allora Vi preghiamo di rivolgerVi direttamente al Vostro Negoziò di mobili.

Наймата директна услуга за обкова

Ако липоват част от комплекта, потърнете настройката с оригинална карта и ни я изпратете на e-mail адреса, посочен по-долу. По този начин можем да доставяме само липсващи елементи от обкова. Ако установите други дефекти по мебелите, Ви съветваме да се обърнете към мебелната къща/магазин, от който сте закупили стоката.

Onze directservice voor losse onderdelen

Wanneer er een onderdeel ontbreekt, kunt u deze servicekaart direct aan onderstaand e-mailadres sturen. Wij kunnen langs deze weg echter alleen losgedelen versturen. Mocht u een ander probleem aan uw meubel hebben, verzoeken wij u contact op te nemen met uw meubeldealer.

Nasz bezpośredni serwis części montażowych

Jeżeli brakuje części koniecznych do montażu, prosimy o przesłanie nam niniejszej karty serwisowej na niżej podany adres e-mailowy. W ten sposób możemy przesyłać Państwu tylko brakujące części. W przypadku innych reklamacji dotyczących mebla, prosimy zgłosić się do salonu meblowego, w którym został dokonany zakup.

Servis za okove

U službuju da nedostaje neki od dijelova molimo vas da na dolje navedenu mail adresu pošaljete ovaj servisni obrazac. Na ovaj način mogli su dostaviti samo okove. U slučaju da imate dodatne prigovore vezane uz komad namještaja molimo vas da se obratite izravno trgovini namještaja gdje je isti kupljen.

Direktkezelésünk vasalatók esetén

Ha hiányzik egy vasalató, ezt a kártyát közvetlenül elküldheti az alább található címre. Azonban csak vasalatókat tudunk így küldeni. Amennyiben másfajta reklamáció áll fenn bútorárbáját illetően, forduljon közvetlenül a bútoráruházhoz.

Naš priamy servis pre diely kovania

Ak by Vám chýbala nejaká časť kovania, môžete poslať túto servisnú kartu poslať e-mailom na nižšie uvedenú adresu. Diely kovania vieme poslať iba týmto spôsobom. Ak by ste mali inú reklamáciu ohľadom Vašho nábytku, obraťte sa priamo na Vašu predajňu nábytku.

Naše direktno uslužbne storitve za okovje

Če vam manjka kakšno okovje, lahko to servisno kartico pošljete po e-pošti direktno na spodnji naslov. Po tej poti vam lahko pošljemo samo okovje. Če želite reklamirati kakšen drug del pohištva, se obrnite neposredno na vašo trgovino pohištva.

Service-ul nostru direct pentru feronerie

În cazul în care vă lipseşte o piesă de feronerie puteţi să trimiteţi direct acest card de service prin e-mail la adresa de mai jos. Noi nu putem expedia piese de feronerie decât pe această cale. Dacă aveţi o altă reclamaţie referitoare la piesa de mobilier, atunci vă rugăm să vă adresaţi direct la magazinul dvs. de mobilă.

Наши прямой сервис для поставок фурнитуры

Если окажется, что Вам не хватает того или иного элемента фурнитуры, Вы можете отправить сервисную карту по факсу непосредственно на нижеприведенный адрес электронной почты. Однако, таким образом мы можем пересылать лишь фурнитуру. Если же у Вас возникнут иные претензии относительно приобретенной мебели, пожалуйста, обращайтесь непосредственно в организацию, осуществляющую продажу.

Vår directservice för beslagsdelar

Om du saknar en beslagsdel kan du skicka detta servicekort direkt till e-postadressen som anges nedan. Tänk på att detta är den enda möjligheten att skicka beslagsdelar till dig. Om du vill reklamera din möbel av en annan anledning måste du kontakta ditt möbelfhus direkt.

Nuestro servicio directo para accesorios

Si le falta algún accesorio, puede enviar esta tarjeta de servicio directamente a la siguiente dirección. No obstante, por este método solo podemos enviar accesorios. Si tiene alguna otra objeción sobre su mueble, consulte directamente con su mueblería.

Donatitiz jedin obraditiz servisimiz

Bi donatitiz ekrizito bu servis kartini dogrudan isagidiz bukunan adrese dogrudan mail yazabiliriniz. Sadece bu yolla donatitiz gonderebiliriz. Mobilyanizda baska sikayetleriniz varsa lutfen dogrudan mobilya satilclinizla danisiz.

nr	L[mm]	B[mm]	T[mm]	Menge	Coll
1	1954	400	16	1	2/2
2	1954	400	16	1	2/2
3	502	401	16	1	1/2
4	468	362	16	2	2/2
5	468	325	16	2	2/2
6	468	362	16	1	1/2
7	1122	77	38	1	2/2
8	419	463	16	2	1/2
9	419	410	16	2	1/2
10	328	387	4	1	2/2
11	1963	478	3	1	2/2

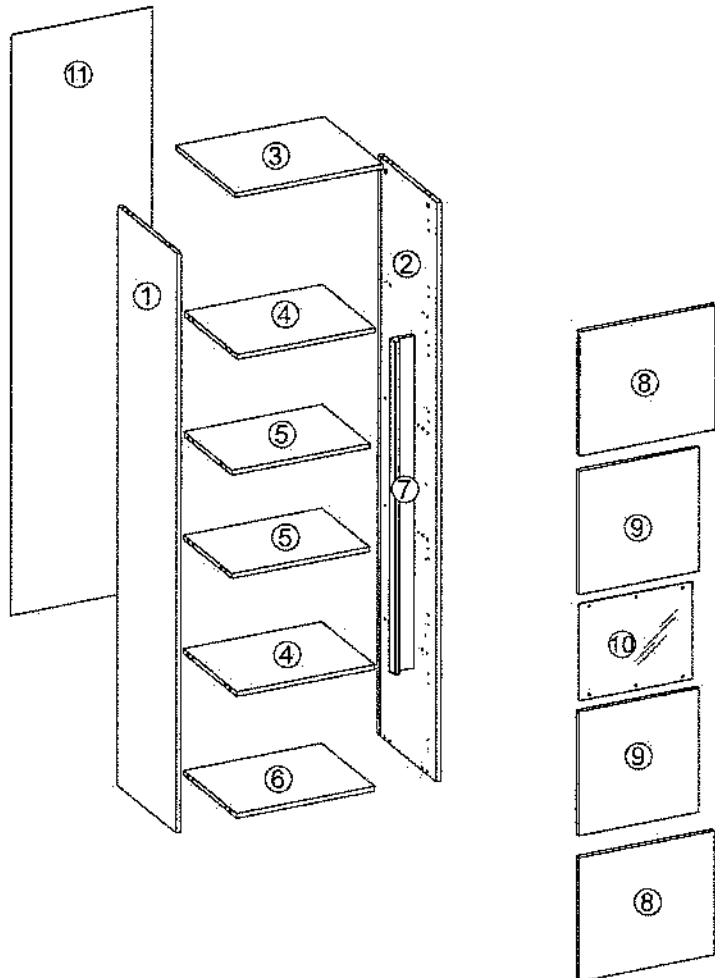

D
GB
CZ
F
I
BG
NL
PL
HR
HU
SK
SLO
RO
RUS
S
ES
TR

Modell: CITY / GIRON 30

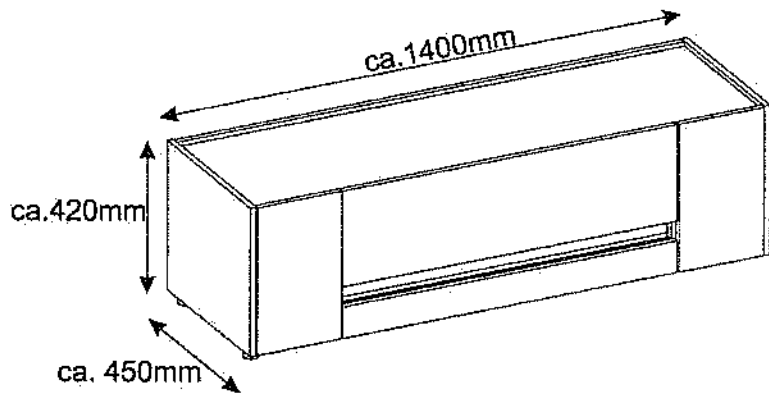

- Ⓛ Montageanleitung
- Ⓝ Handleiding voor de montage
- Ⓜ Montaj talimatı
- Ⓧ Notice de montage
- Ⓢ Montážní návod
- Ⓟ Szerelési útmutató
- Ⓠ Assembly Instructions
- Ⓡ Instrukcja montażu
- Ⓡ Инструкция по монтажу
- Ⓡ Istruzioni di montaggio
- Ⓡ Návod na montáž
- Ⓡ Instrucțiunile de montaj
- Ⓡ Instrucciones de montaje
- Ⓡ Montaj Talimatı

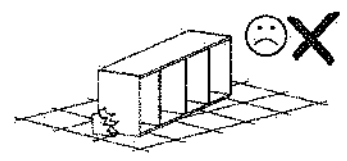
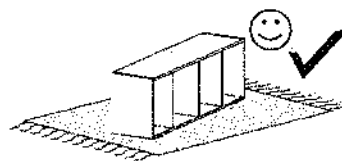
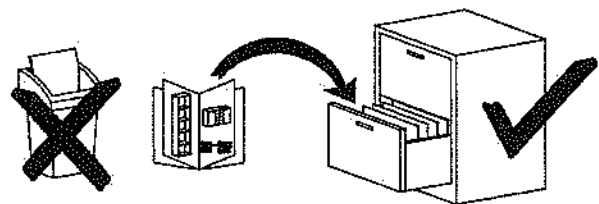
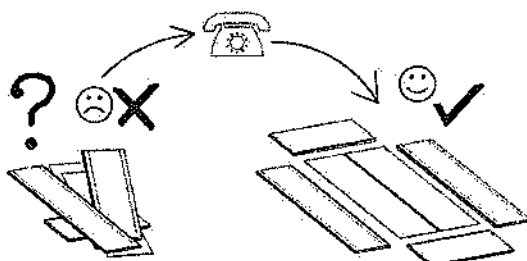
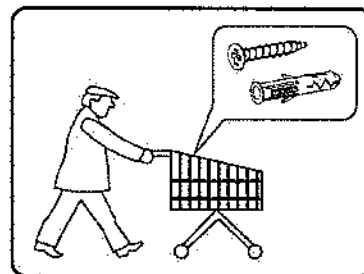
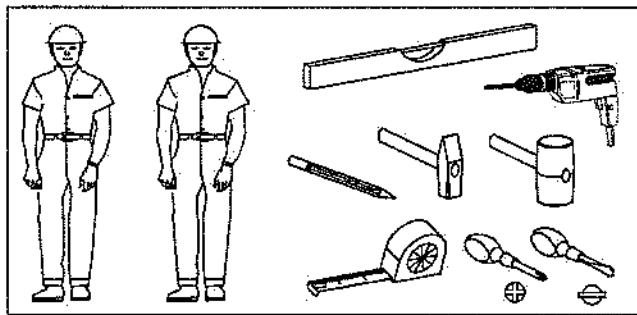

2,5h

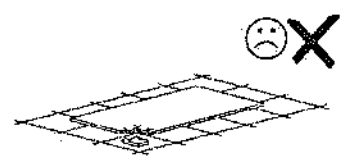
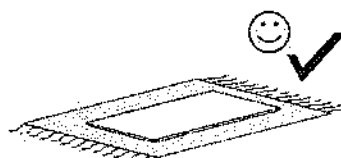







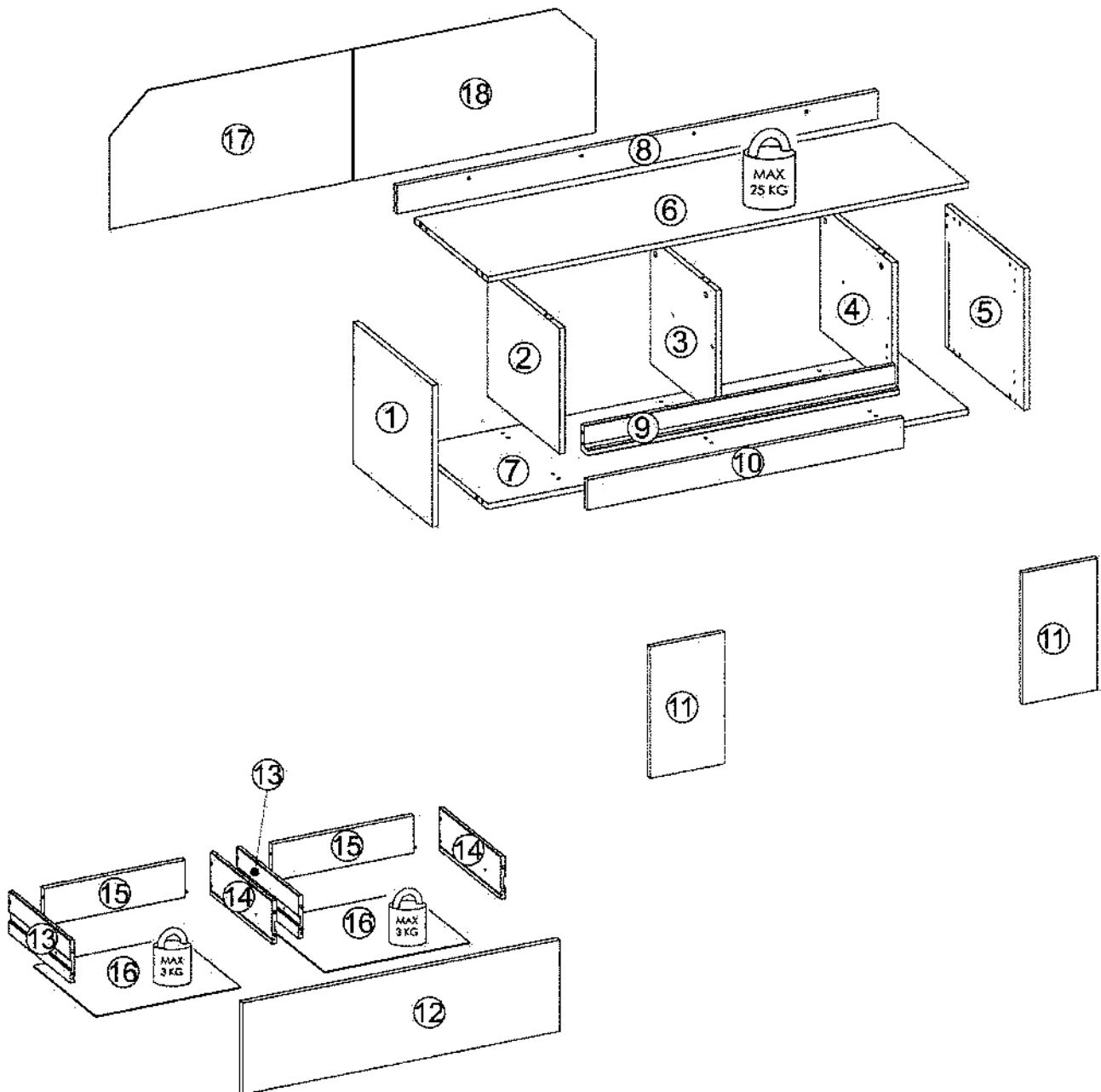

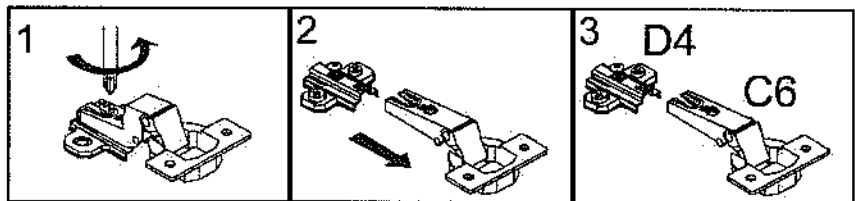
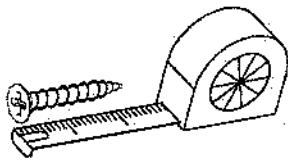
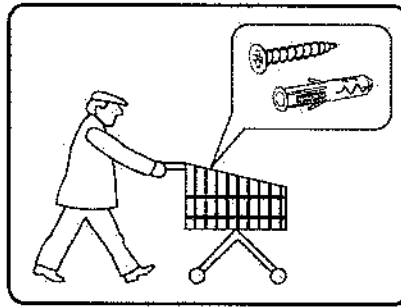

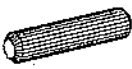









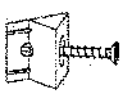
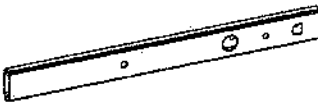

nr	L[mm]	B[mm]	T[mm]	Menge	Coll
1	400	450	16	1	1/2
2	355	411	16	1	1/2
3	355	373	16	1	2/2
4	355	411	16	1	1/2
5	400	450	16	1	1/2
6	1368	416	16	1	2/2
7	1368	412	16	1	2/2
8	1368	80	16	1	2/2
9	886	77	38	1	2/2
10	900	85	16	1	2/2
11	397	228	16	2	1/2

nr	L[mm]	B[mm]	T[mm]	Menge	Coll
12	900	258	16	1	1/2
13	350	120	12	2	1/2
14	350	120	12	2	1/2
15	402	105	12	2	2/2
16	412	358	3	2	2/2
17	371	688	3	1	2/2
18	371	688	3	1	2/2



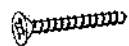

B1  $\varnothing 8 \times 35$ x26	B2  $\varnothing 6 \times 30$ x4	A1  $\varnothing 7 \times 50$ x14	W2  x1	I7  x10
K1  x16	K10  x16	D4  x4	C6  x4	G34  $3,5 \times 16$ x10
G47  $6,3 \times 13$ x8	G49  4×16 x18	F13  x4	N1  $M4 \times 9$ x4	I1  x4
H5  x4	W1  x1	M11  x2	G50  3×20 x22	
P10  x5	G36  4×30 x5	Z6  x4		



I

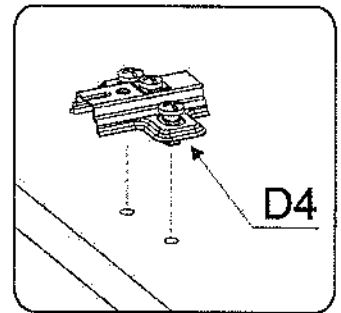
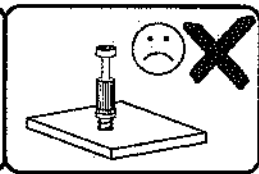
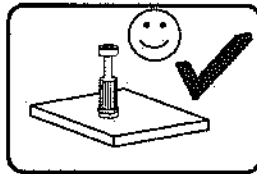
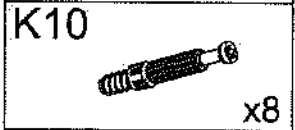
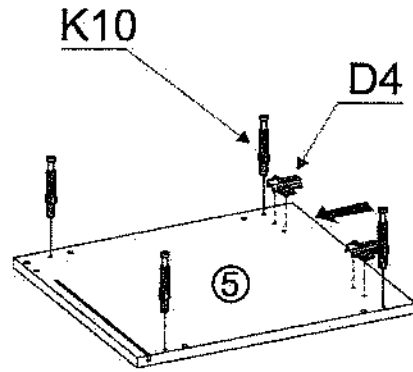
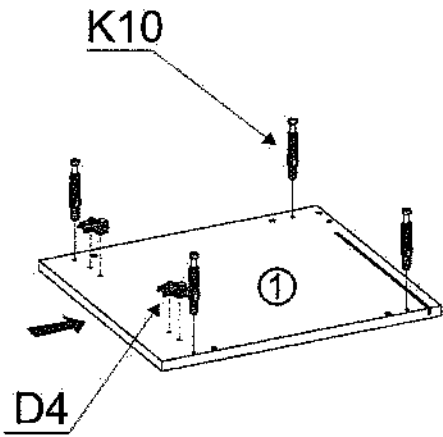

II

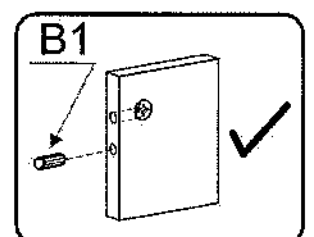
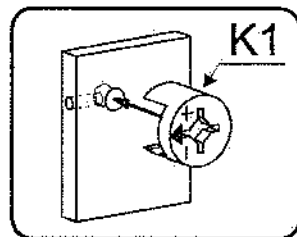
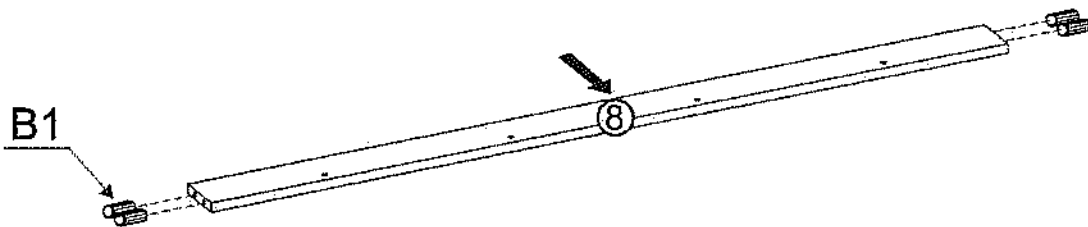
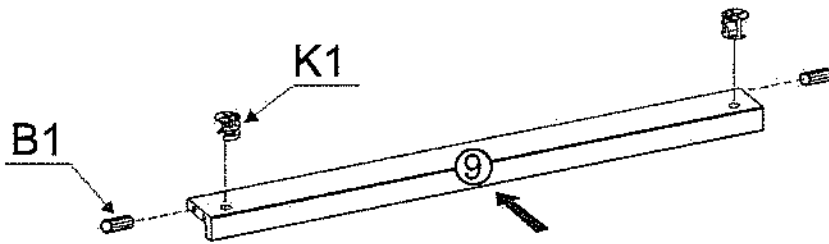
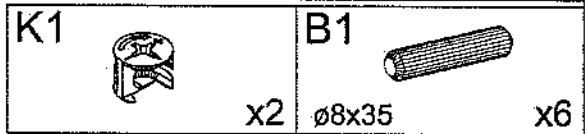



III

H5

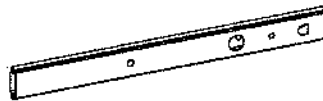

x2

K1



x8

K10



x8

G47



6,3x13

x4

B1

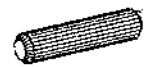

ø8x35

x12

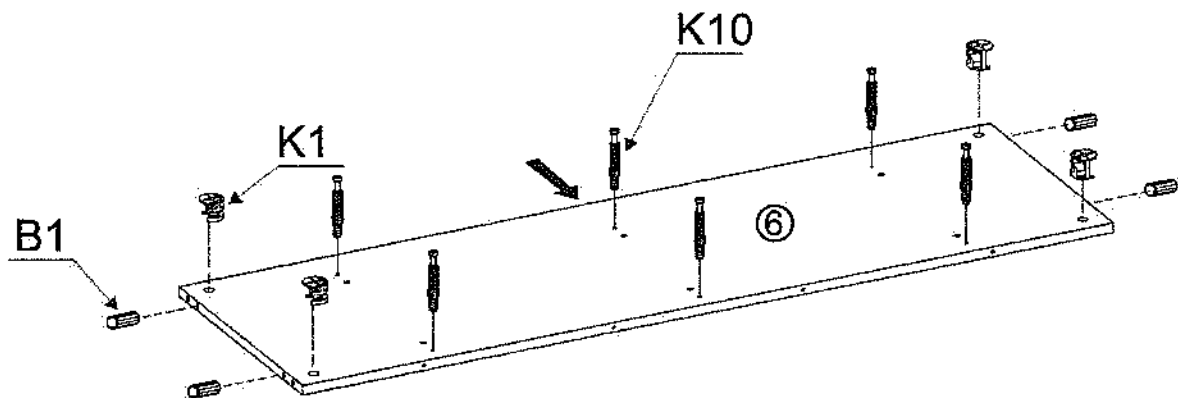
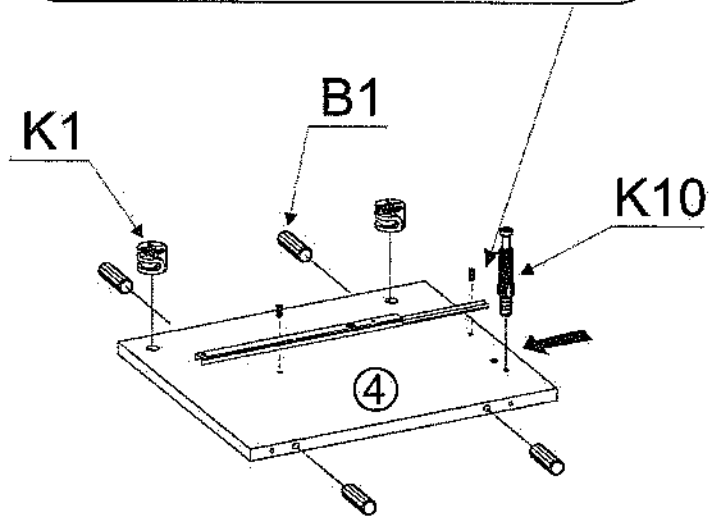
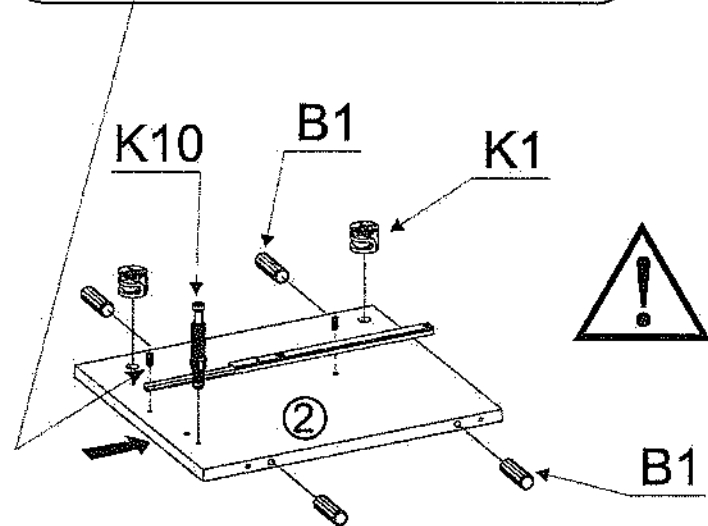
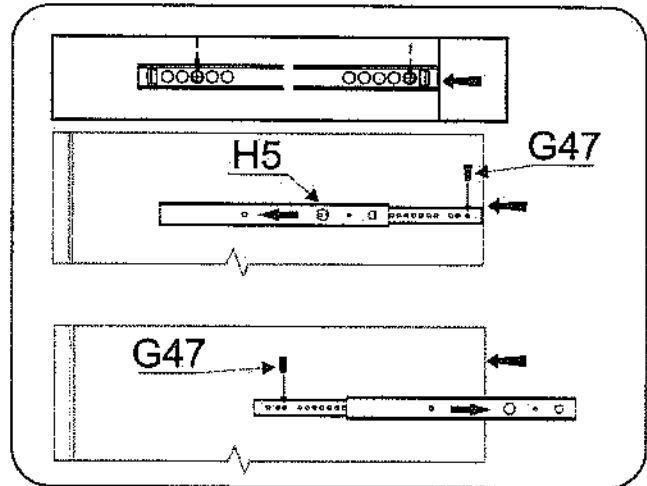
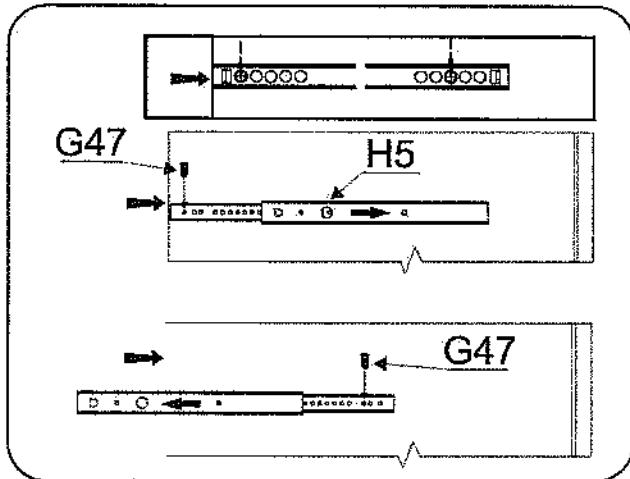



IV

H5

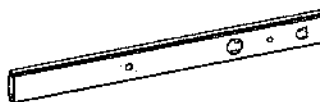

K1



x2

x2

G47



6,3x13

x4

B1



ø8x35

x4

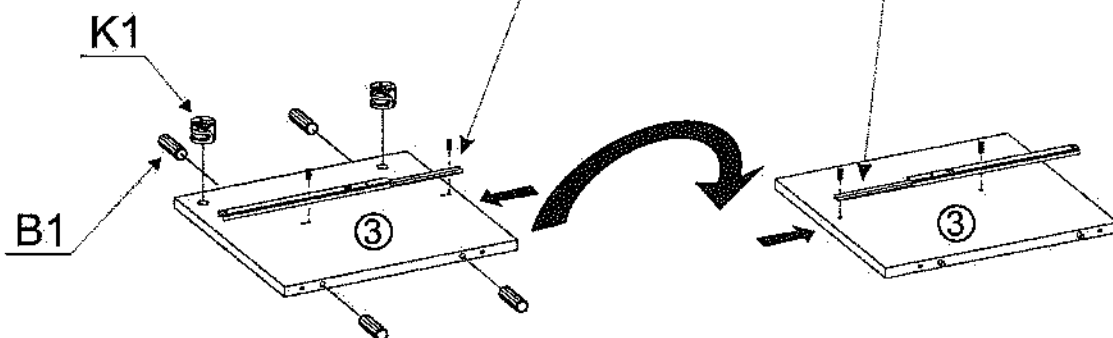
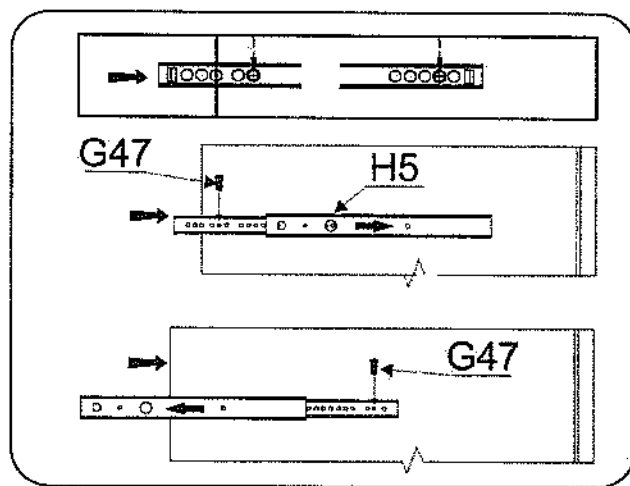
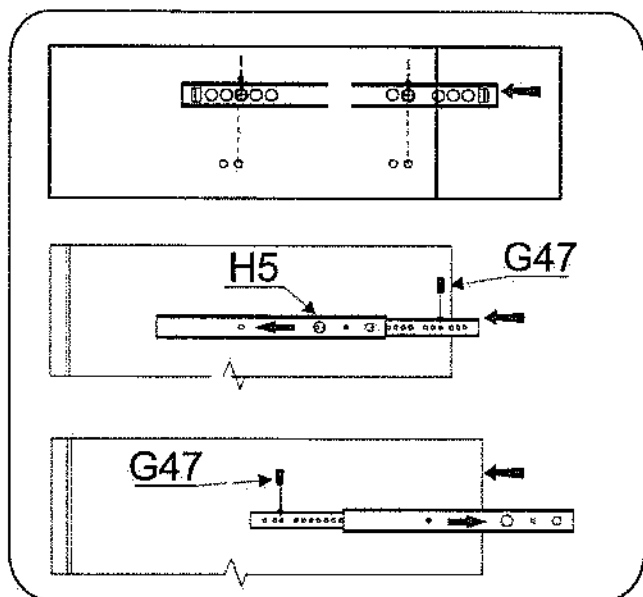





V

B1  $\varnothing 8 \times 35$ x4

K1  x4

F13  x4

G49  4x16 x4

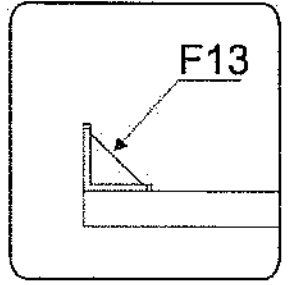
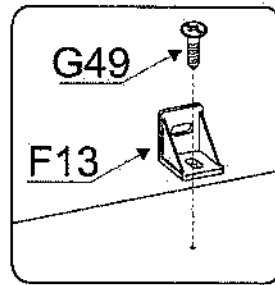
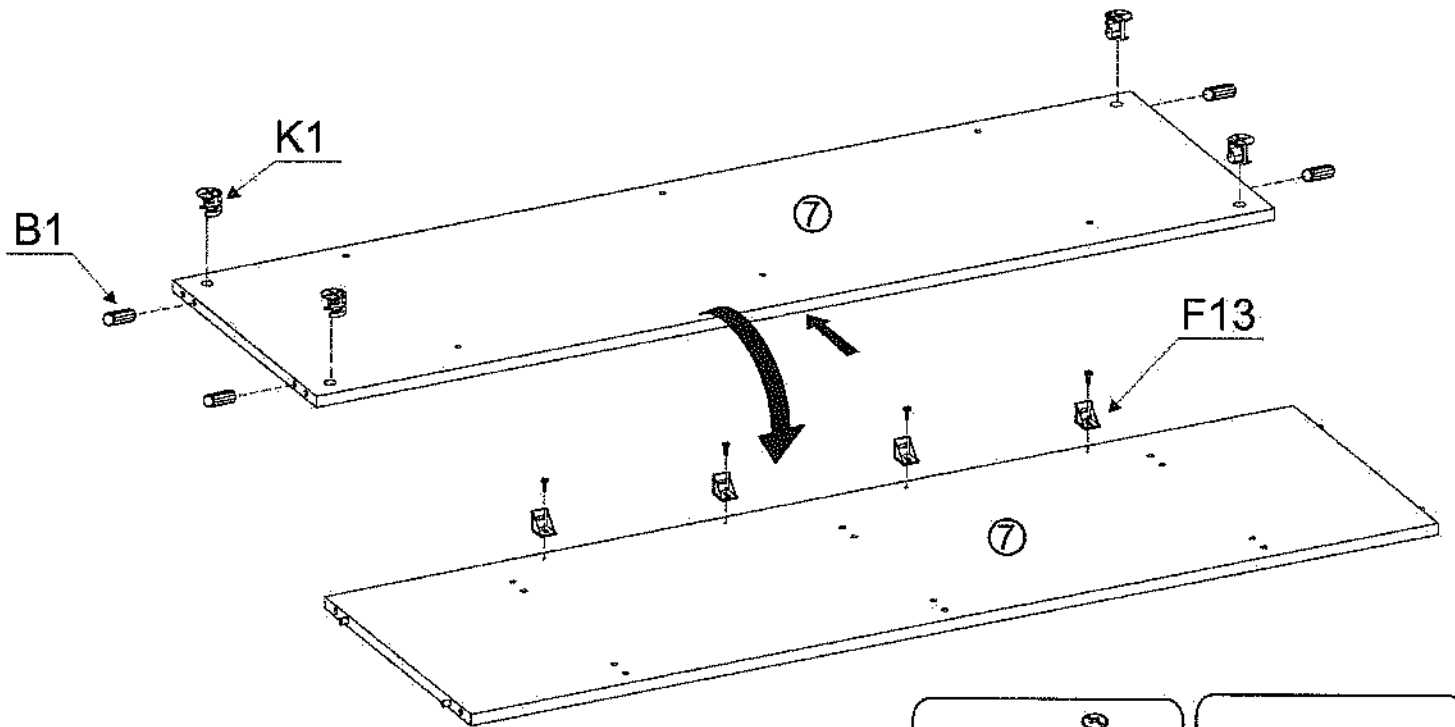

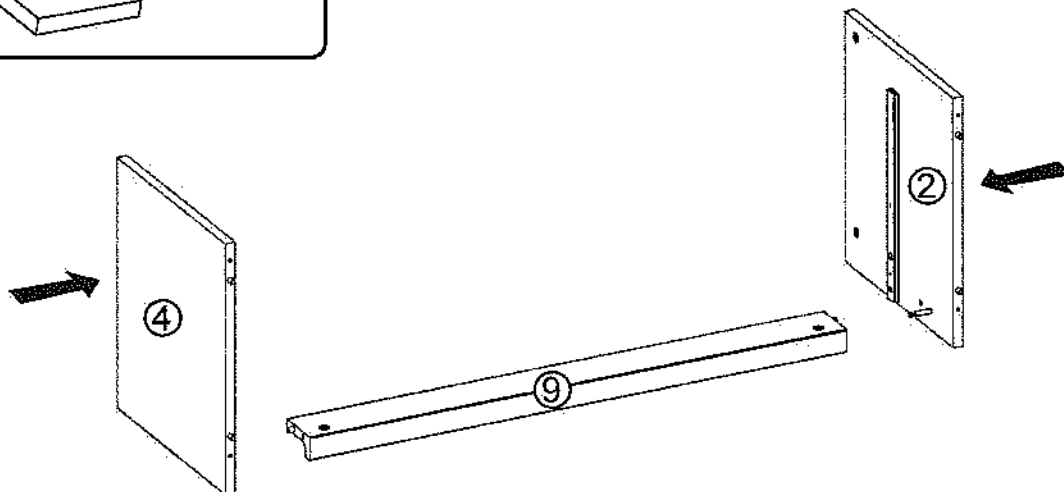
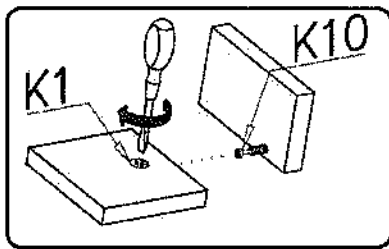

VI



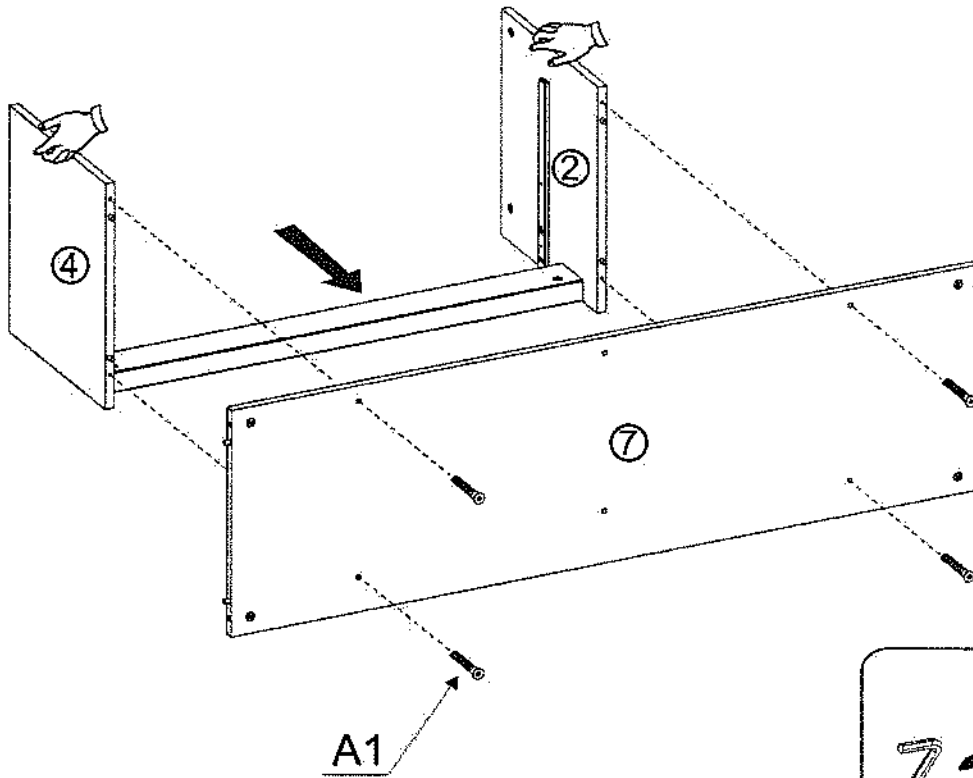

VII

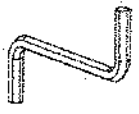

- A1  $\phi 7 \times 50$ x4
- W2  x1

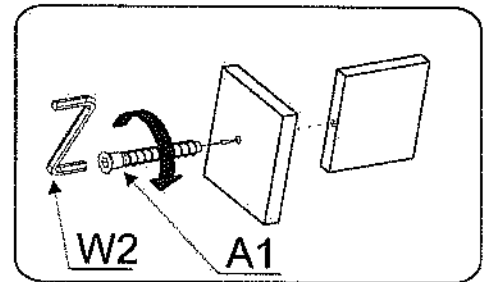

VIII

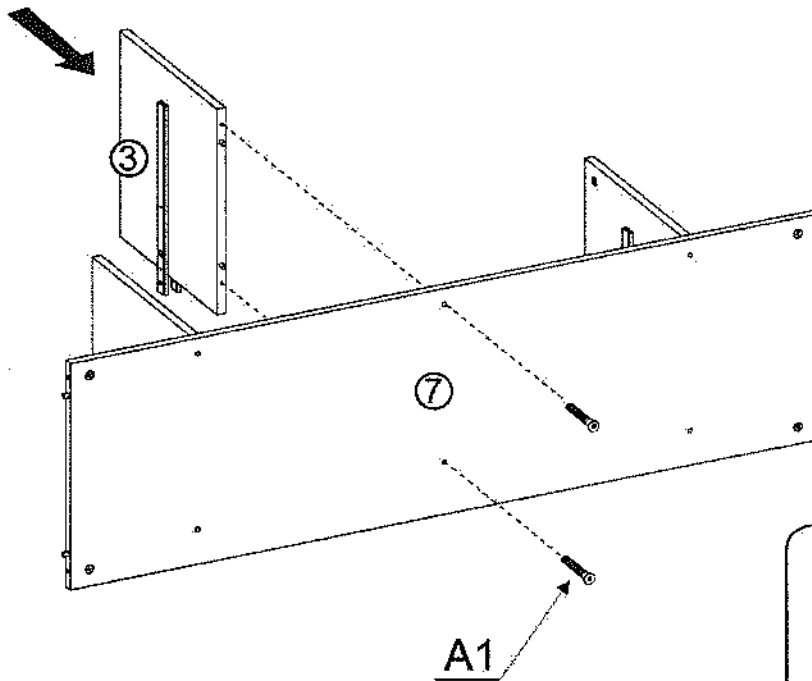

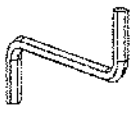
- A1  $\phi 7 \times 50$ x2
- W2  x1

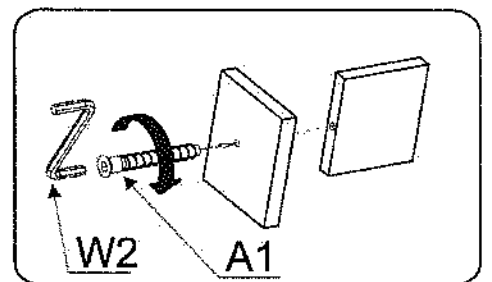

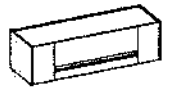

IX

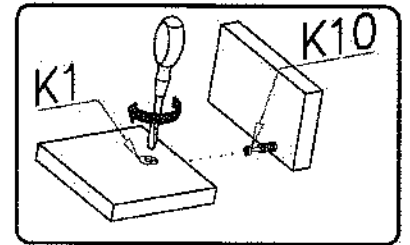
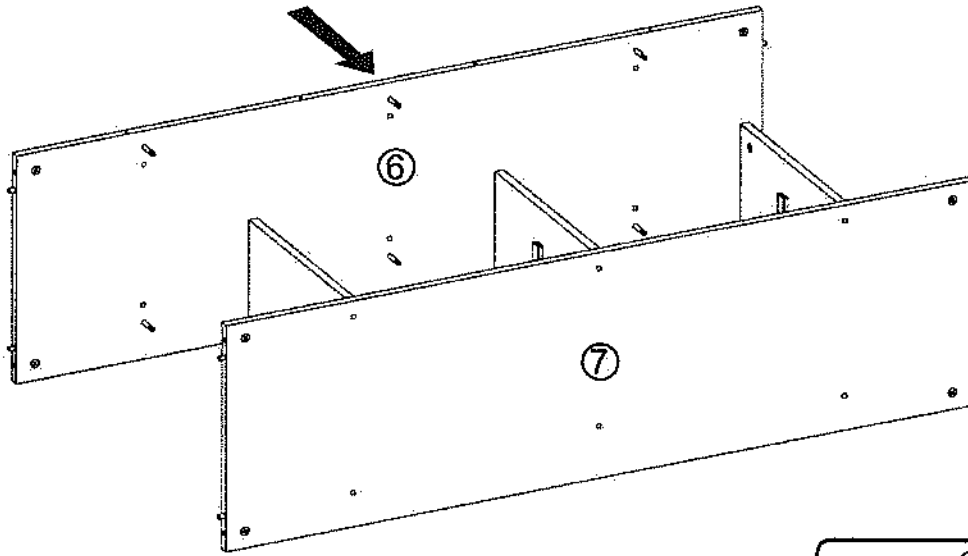

X

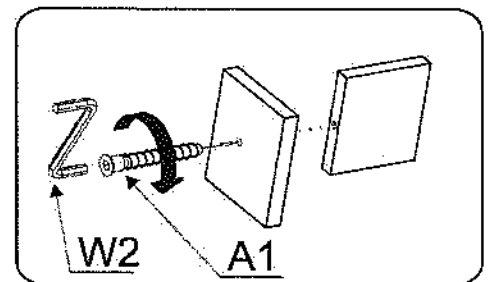
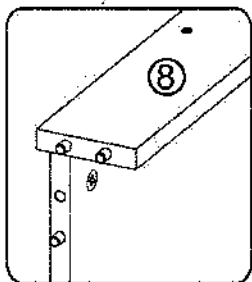
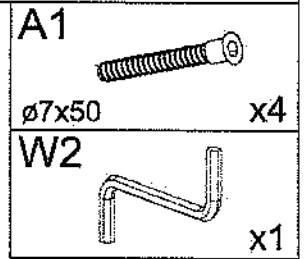
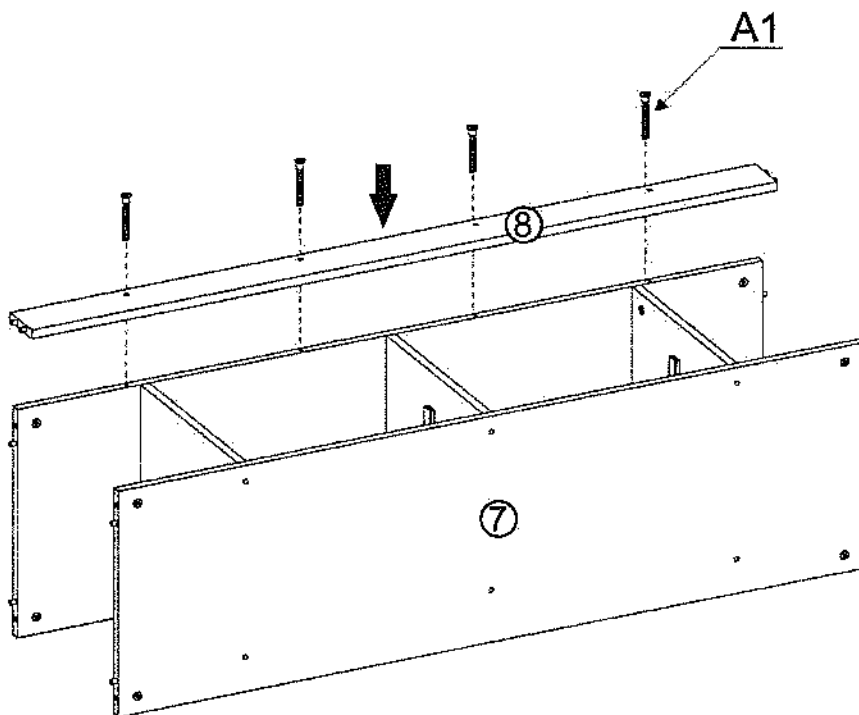

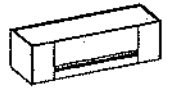

XI

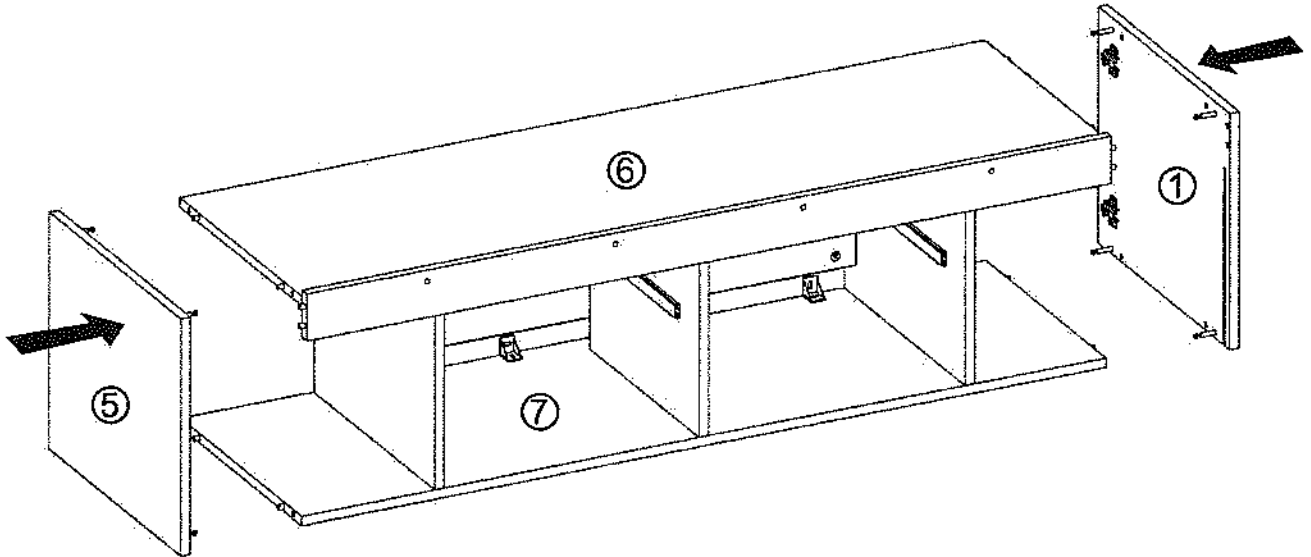
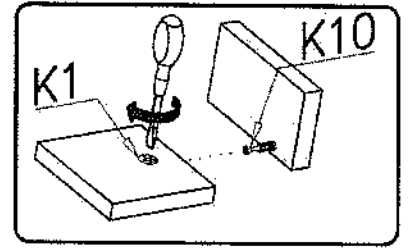
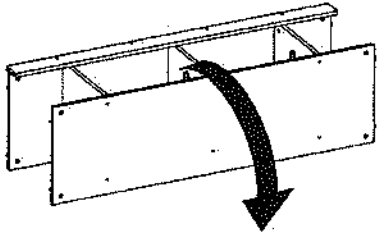

XII

G49

4x16



x4

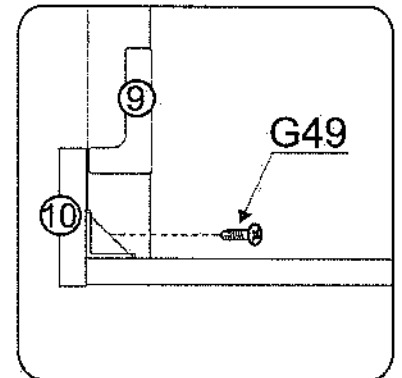
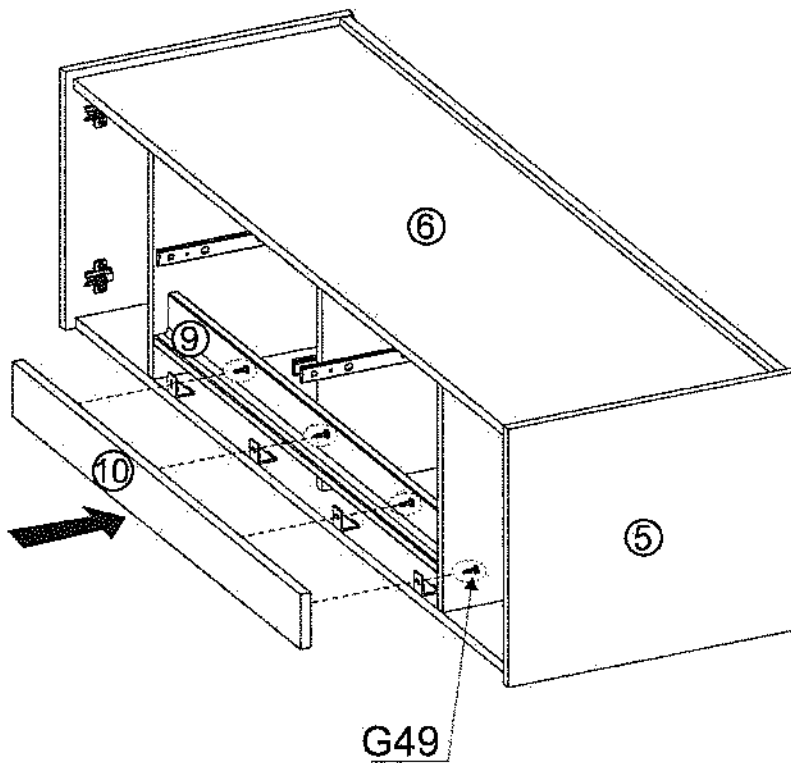





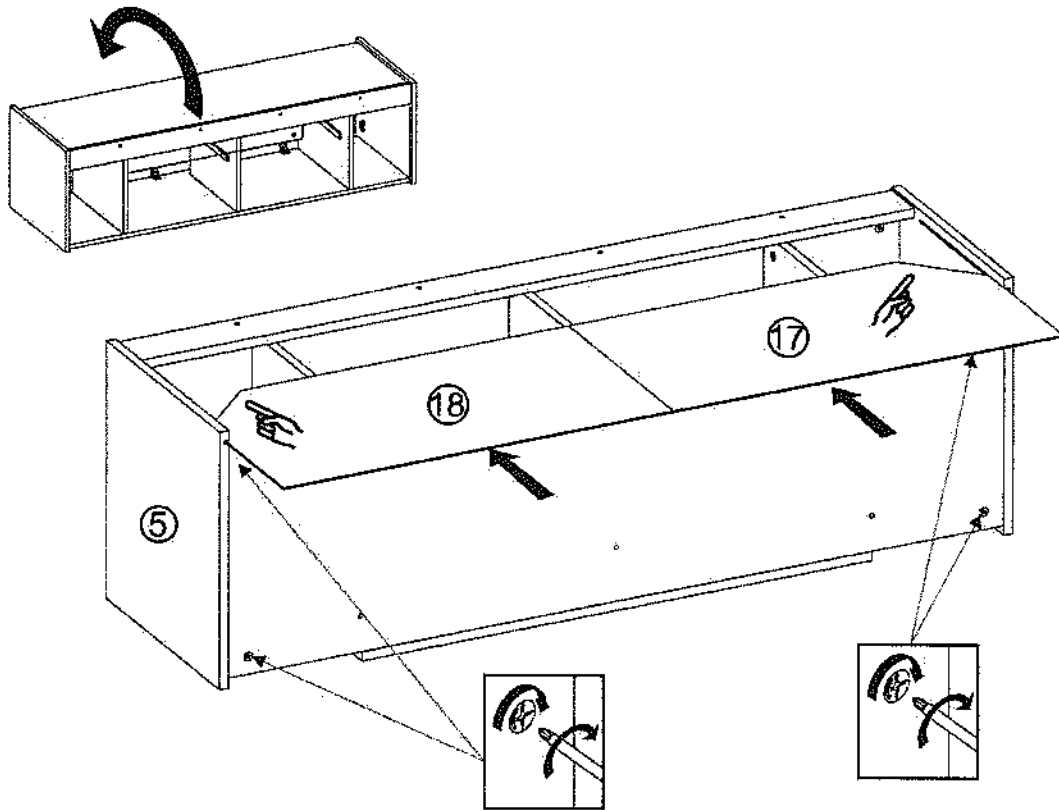

XIII

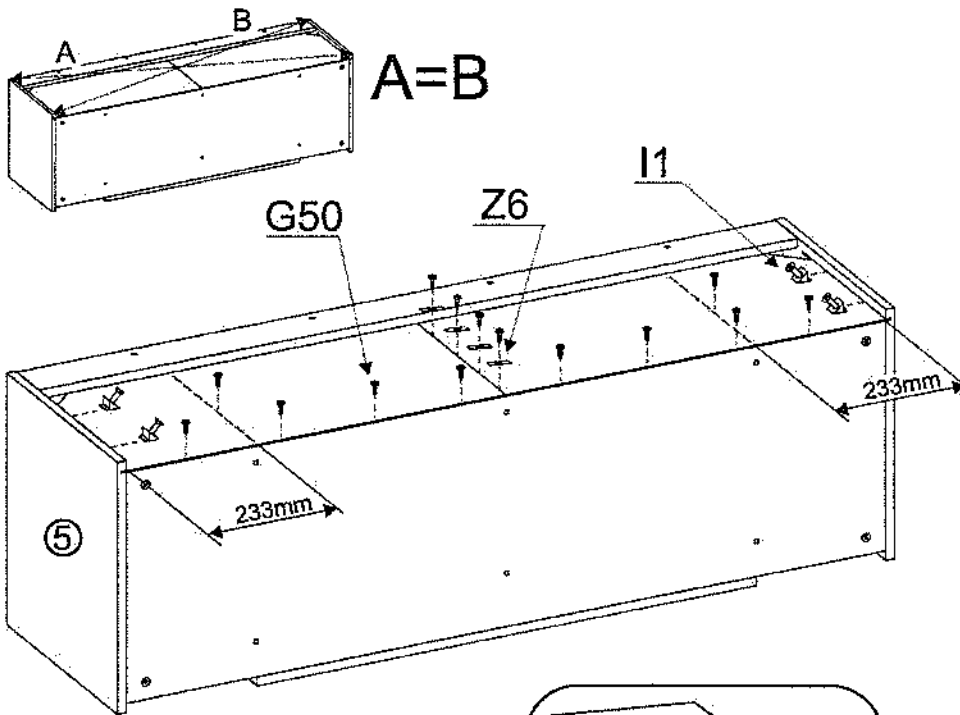

XIV



- G50  x14
- 3x20  x4
- I1  x4
- Z6  x4

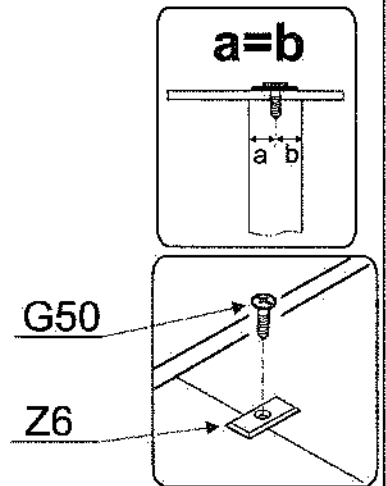
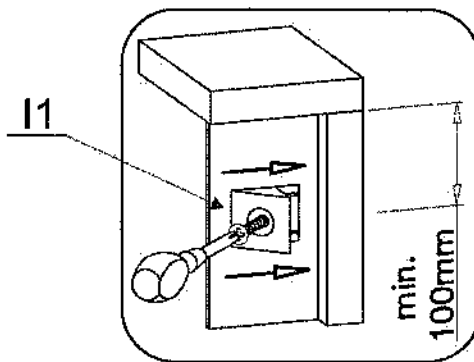
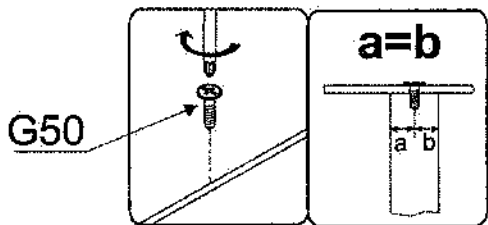





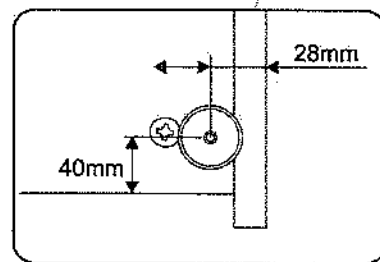
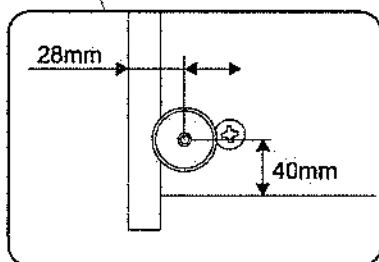
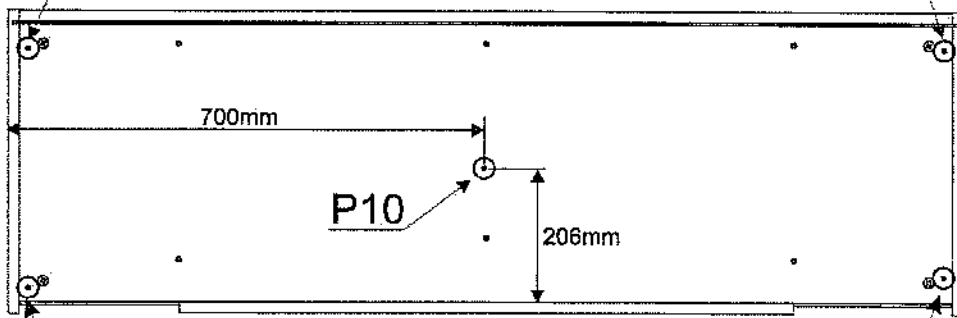
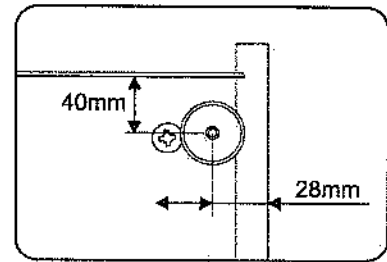
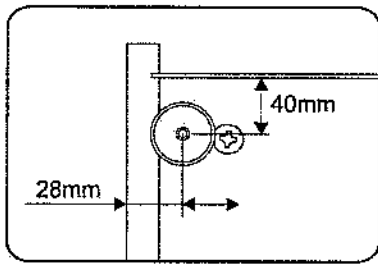
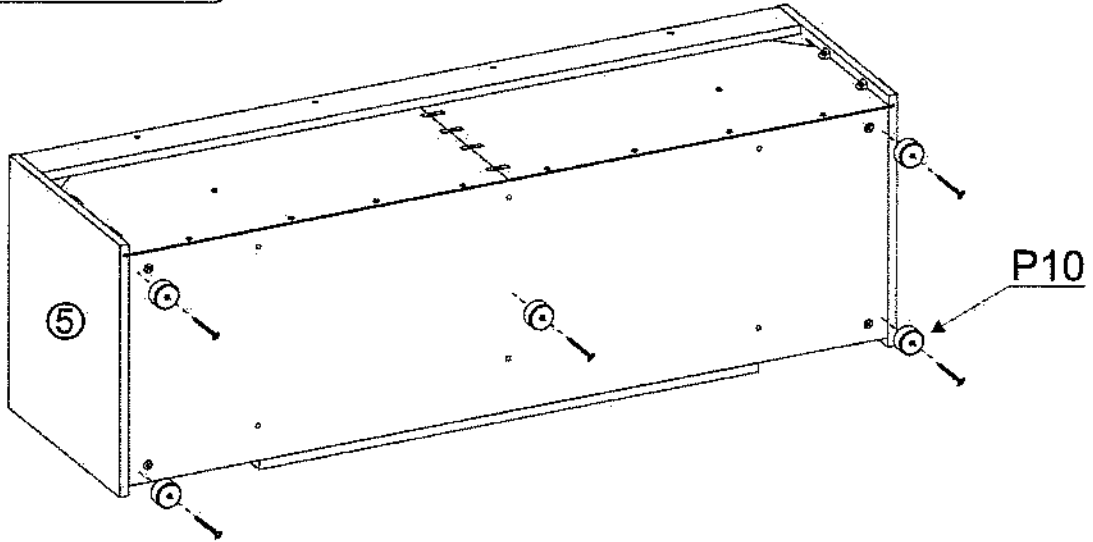
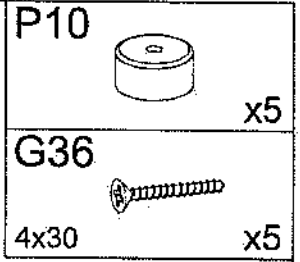
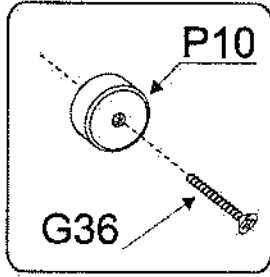

XV



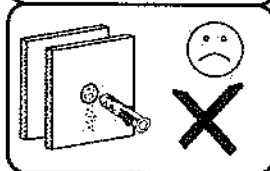
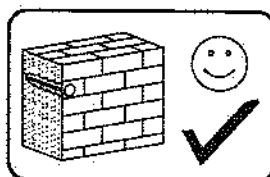
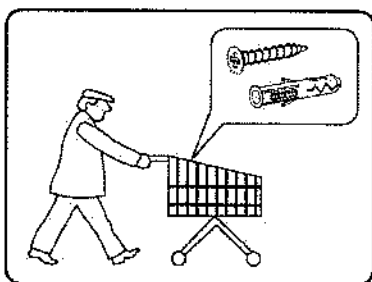

XVI

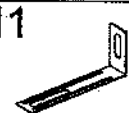



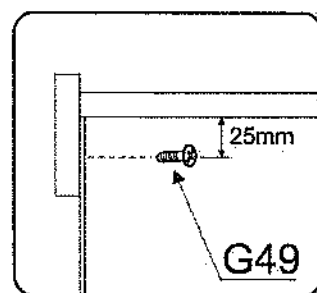
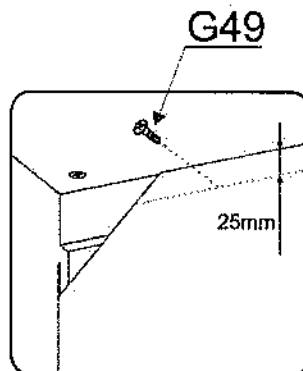
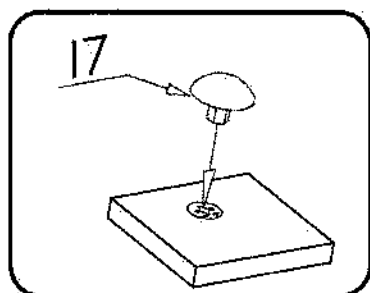
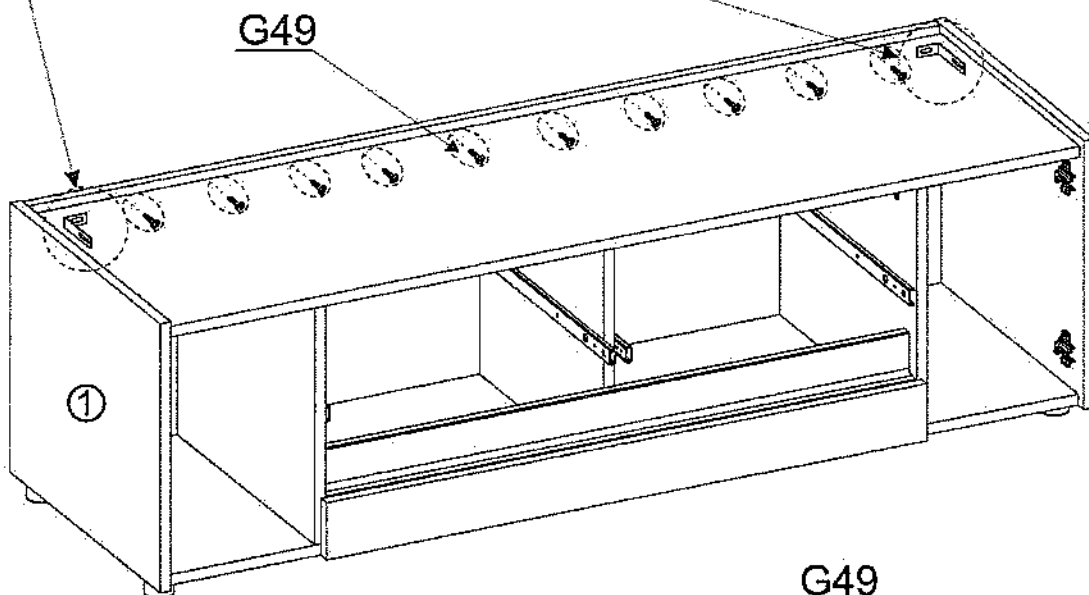
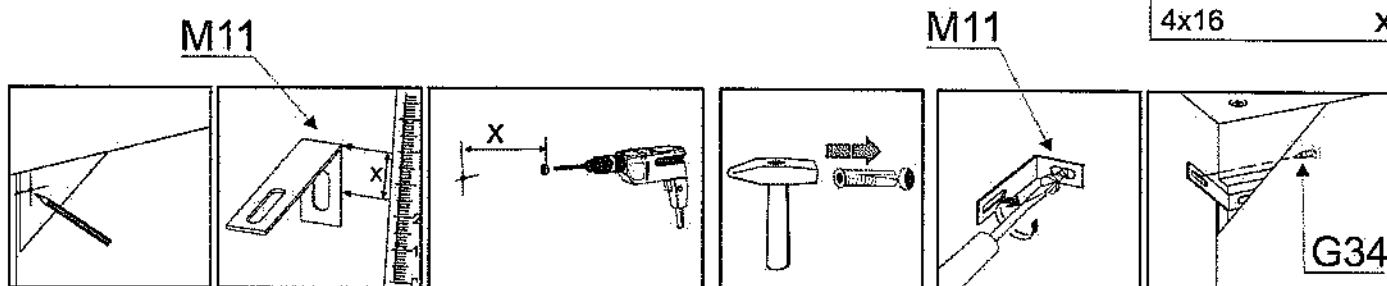

- G34  3,5x16 x2
- M11  x2
- I7  x10
- G49  4x16 x10



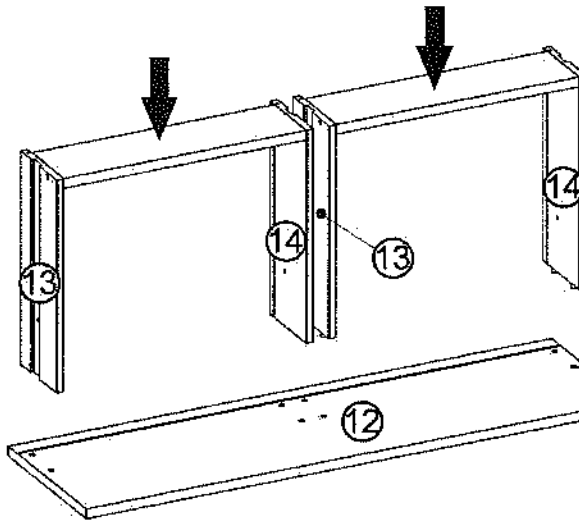
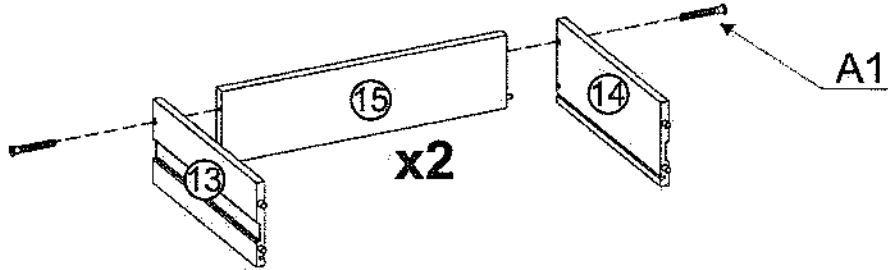
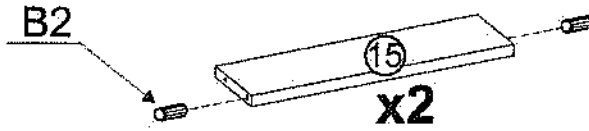

XVII

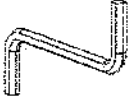

- B2  x4
ø6x30
- A1  x4
ø7x50
- W2  x1
- W1  x1



0,5h

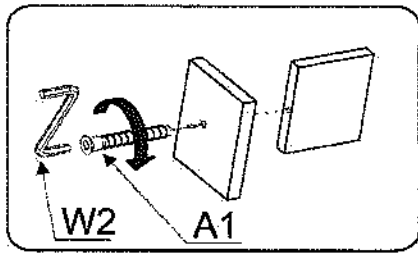
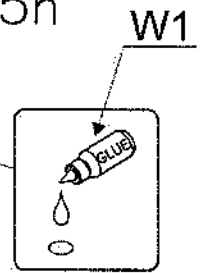

XVIII

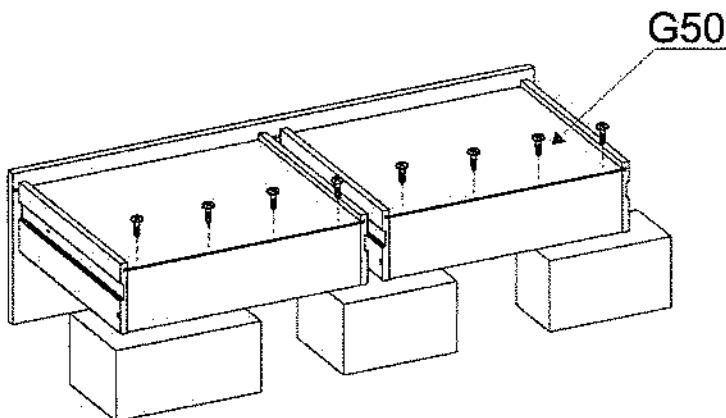
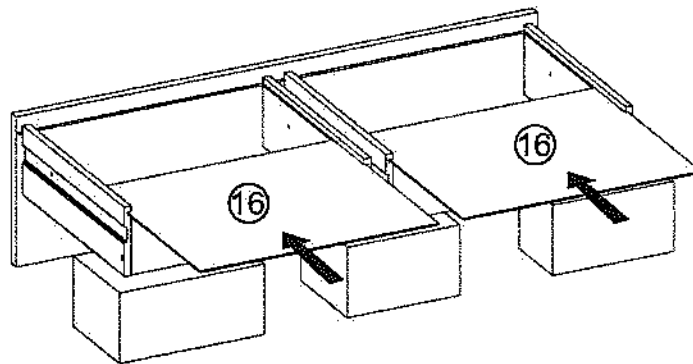

- G50  x8
3x20

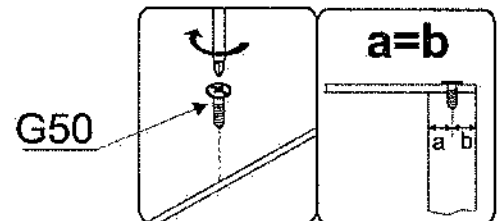



XIX

N1

M4X9



x4

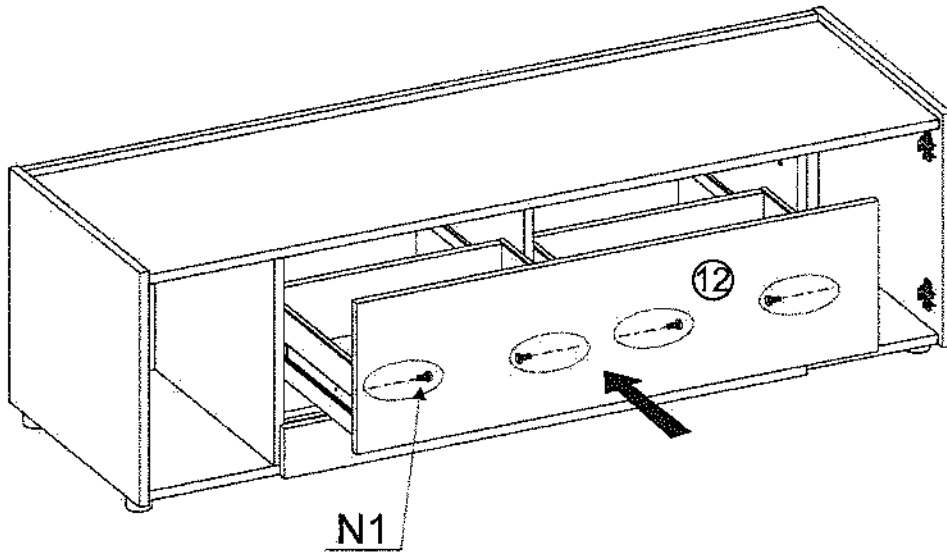
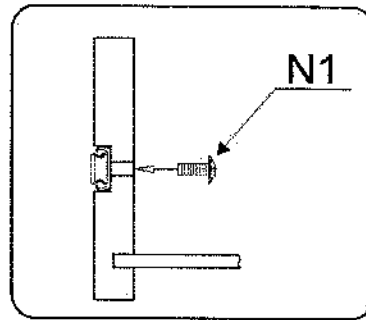
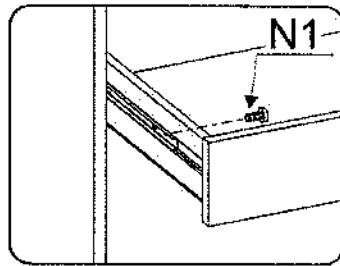
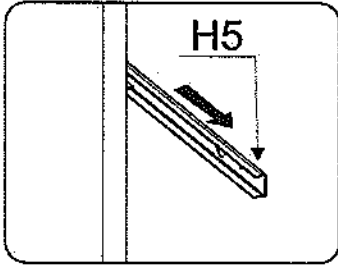

XX

C6

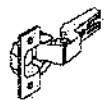

x4

G34



3,5x16

x8

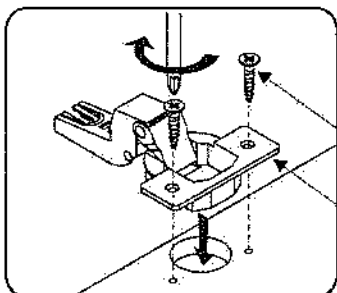

G34

C6

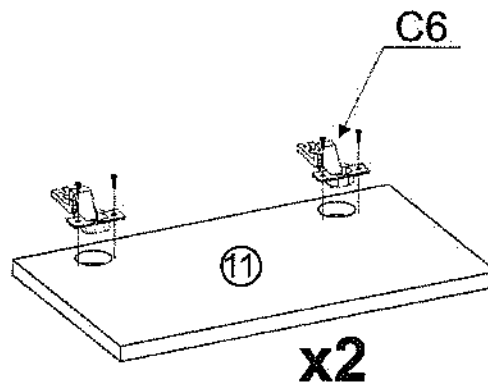

x2



XXI

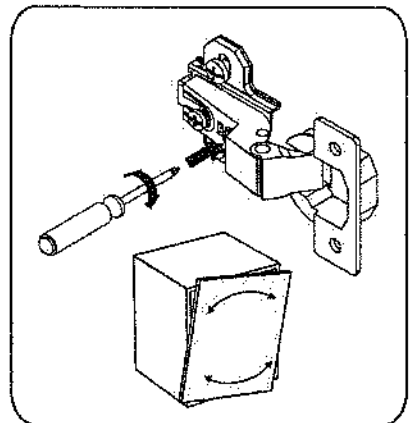
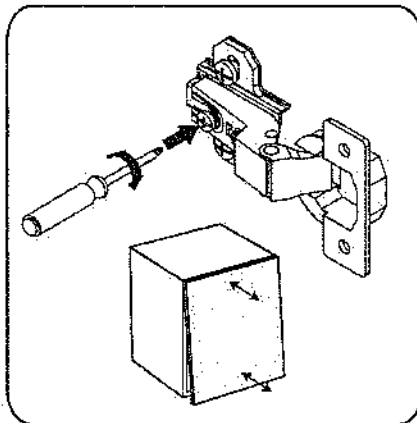
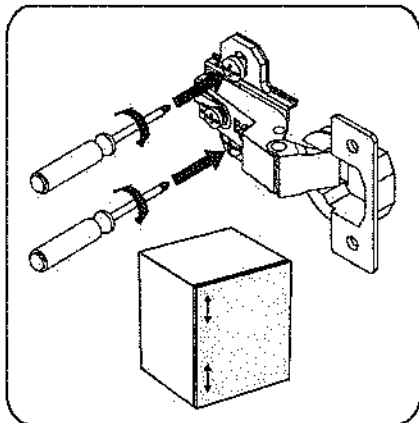
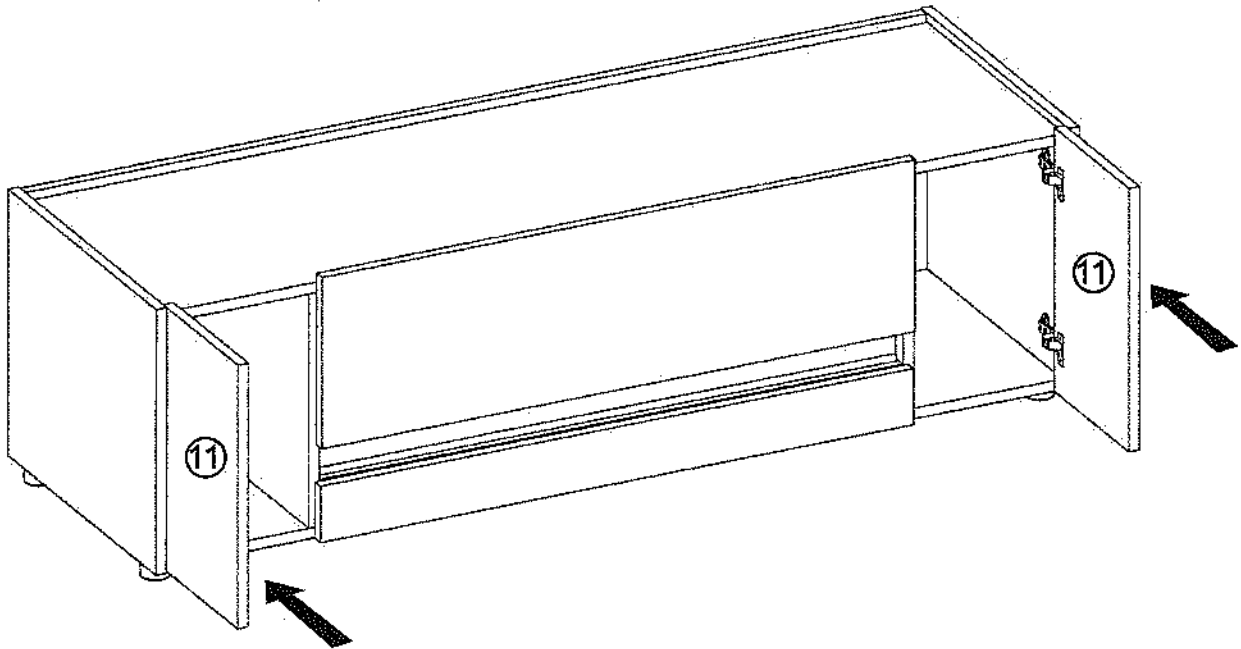
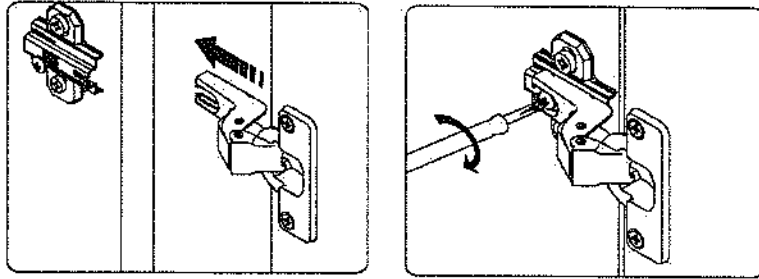

Name • Nom • Name • Naam • Nazwa • Иméно
• Νόζον • Név • Denumire • Isim • Извание

Nr • No • N° • Номер • Č • Sz

Typ • Type • Tip • Τύπος • Tipo • Tun

CITY / GIRON

30

Unser Direktservice für Beschlagteile

Sollte Ihnen ein Beschlagteil fehlen, können Sie diese Servicekarte direkt an die untenstehende Adresse mailen. Wir können allerdings nur Beschlagteile auf diesem Wege verschicken. Sollten Sie eine andere Beanstandung an Ihrem Möbelstück haben, so wenden sie sich bitte direkt an Ihr Möbelhaus.

Our direct online service for fitting
If a fitting part is missing, you can e-mail this service card directly to the address below. However, we can only send fitting parts in this way, if you have any other cause for complaint concerning your item of furniture, please contact your furniture store directly.

Nášo přímé služby pro kování

Chybí-li vám nějaký díl z kování, můžete tuto servisní kartu odeslat e-mailem přímo na níže uvedenou adresu. Touto cestou však můžeme rozeslat jen díly kování. Pokud byste reklamovali jiný díl nábytku, obraťte se přímo na svého prodejce nábytku.

Bien servir la notice de montage

Si il vous manque une ferrure, veuillez envoyer directement la présente carte service à l'adresse e-mail indiquée ci-dessous. Cependant, ceci nous permet uniquement d'envoyer des ferrures. Pour tout autre type de réclamation concernant votre meuble, veuillez contacter directement votre magasin d'ameublement.

Il nostro servizio diretto per l'ordine della ferramenta

Qualora Vi dovesse mancare un pezzo di fissaggio, allora Vi preghiamo di inviare questa carta di servizio immediatamente all'indirizzo sottostante. Possiamo inviare i pezzi di fissaggio solamente per mezzo di questo procedimento. Qualora dovesse avere qualche altra reclamazione in merito al mobile, allora Vi preghiamo di rivolgerVi direttamente al Vostro Negozio di mobili.

Нашата директна услуга за обкова

Ако липсват части от комплекта, попълнете настоящата сервисна карта и ни я изпратете на e-mail адреса, посочен по-долу. По този начин можем да доставяме само липсващи елементи от обкова. Ако установите други дефекти по мебелите, Ви съветваме да се обръщате към мебелната къща/магазин, от който сте закупили стоката.

Onze directservice voor losse onderdelen

Wanneer er een onderdeel ontbreekt, kunt u deze servicekaart direct aan ons datareel of e-mailadres sturen. Wij kunnen langs deze weg echter alleen losse beslagdelen verzuren. Mocht u een ander probleem aan uw meubel hebben, verzeken wij u contact op te nemen met uw meubeldealer.

Nasz bezpośredni serwis części montażowych

Jeżeli brakuje części koniecznych do montażu, prosimy o przesłanie nam niniejszej karty serwisowej na niżej podany adres e-mailowy. W ten sposób możemy przesłać Państwu tylko brakujące części. W przypadku innych reklamacji dotyczących mebla, prosimy zgłosić się do salonu meblowego, w którym został dokonany zakup.

Servis za okove

U slučaju da nedostaje neki od dijelova molimo vas da ne dolje navedenu mail adresu pošaljete ovaj servisni obrazac. Na ovaj način mogu se dostaviti samo okovi. U slučaju da imate dodatna prigovore vezane uz komad namještaja molimo vas da se obratite izravno trgovini namještaja gdje je isti kupljen.

Direktzorgálatunk vasalatok esetén

Ha hiányzik egy vasalat, ezt a kártyát közvetlenül elküldheti az alábbi látható címre. Azonban csak vasalatoskat tudunk így küldeni. Amennyiben másfajta reklamáció áll fenn bútorárbaját illetően, forduljon közvetlenül a bútorházhoz.

Náš priamy servis pre časti kovania

Ak by Vám chýbalo nejaká časť kovania, môžete poslať túto servisnú kartu pošťou e-mailom na nižšie uvedenu adresu. Diely kovania vieme poslať iba týmto spôsobom. Ak by ste mali inú reklamáciu ohľadom Vášho nábytku, obráťte sa priamo na Vašu predajňu nábytku.

Naše direktno uslužbe storitve za okovje

Čo vam manjka kakšno okovje, lahko to servisno kartico pošljete po e-pošti direktno na spodnji naslov. Po tej poti vam lahko pošljemo samo okovje. Če želite reklamirati kakšen drug del pohištva, se obrnite neposredno na vašo trgovino pohištva.

Service-ul nostru direct pentru feronerie

În cazul în care vă lipsesc te piese de feronerie puteți să trimiteți direct această card de service prin e-mail la adresa de mai jos. Noi nu putem expedia piese de feronerie decât pe această cale. Dacă aveți o altă reclamație referitoare la piesa de mobilier, atunci vă rugăm să vă adresați direct la magazinul dvs. de mobilă.

Наш прямой сервис для поставок фурнитуры

Если окажется, что Вам не хватает того или иного элемента фурнитуры, Вы можете отправить сервисную карту по факсу непосредственно на нижеприведенный адрес электронной почты. Однако, таким образом мы можем пересылать лишь фурнитуру. Если же у Вас возникнут иные претензии относительно приобретенной мебели, пожалуйста, обращайтесь непосредственно в организацию, осуществившую продажу.

Vår direktservice för beslagdelar

Om du saknar en beslagsdel kan du skicka detta servicekort direkt till e-postadressen som anges nedan. Tank på att detta är den enda möjligheten att skicka beslagdelar till dig. Om du vill reklamera din möbel av annan anledning måste du kontakta ditt möbels hus direkt.

Nuestro servicio directo para accesorios

Si le falta algún accesorio, puede enviar esta tarjeta de servicio directamente a la siguiente dirección. No obstante, por este método solo podemos enviar accesorios. Si tiene alguna otra objeción sobre su mueble, consulte directamente con su mueblería.

Donatlar için doğrudan servisimiz

Bir donatınız eksikse bu servis kartını doğrudan aşağıda bulunan adrese doğrudan mail yazabilirsiniz. Sadece bu yolla donatıları gönderebiliriz. Mobilyanızda başka şikayetleriniz varsa lütfen doğrudan mobilya satıcınıza danışın.

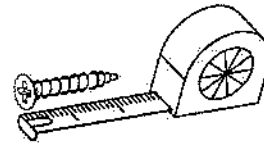

B1 ø8x35 X...	B2 ø6x30 X...	A1 ø7x50 X...
W2 X...	I7 X...	K1 X...
K10 X...	D4 X...	C6 X...
G34 3,5x16 X...	G47 6,3x13 X...	G49 4x16 X...
F13 X...	N1 M4x9 X...	I1 X...
H5 X...	G50 3x20 X...	Z6 X...
P10 X...	G36 4x30 X...	M11 X...
W1 X...		

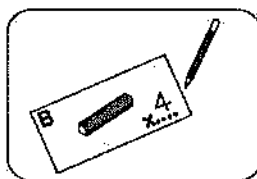

Name • Nom • Nome • Naam • Nazwa • Jméno
• Názov • Név • Denumire • Isim • Название

Nr • No • N° • Номер • Č • Sz

Typ • Type • Tip • Típus • Tipo • Tun

CITY / GIRON

30

Unser Direktservice für Beschlagteile

Sollte Ihnen ein Beschlagteil fehlen, können Sie diese Servicekarte direkt an die untenstehende Adresse mailen. Wir können allerdings nur Beschlagteile auf diesem Wege verschicken. Sollten Sie eine andere Beanstandung an Ihrem Möbelstück haben, so wenden Sie sich bitte direkt an Ihr Möbelhaus.

Our direct order service for fitting
If a fitting part is missing, you can e-mail this service card directly to the address below. However, we can only send fitting parts in this way. If you have any other cause for complaint concerning your item of furniture, please contact your furniture store directly.

Naše příčné služby pro kování

Chybí-li vám nějaký díl z kování, můžete tuto servisní kartu odeslat e-mailem přímo na níže uvedenou adresu. Touto cestou však můžeme rozeslat jen díly kování. Pokud byste reklamovali jiný díl nábytku, obraťte se přímo na svého prodejce nábytku.

Bien étudier la notice de montage

Si vous manquez une ferrure, veuillez envoyer directement la présente carte service à l'adresse e-mail indiquée ci-dessous. Cependant, ceci nous permet uniquement d'envoyer des ferrures. Pour tout autre type de réclamation concernant votre meuble, veuillez contacter directement votre magasin d'aménagement.

Il nostro servizio diretto per l'ordine della ferramenta

Qualora Vi dovesse mancare un pezzo di fissaggio, allora Vi preghiamo di inviare questa carta di servizio immediatamente all'indirizzo sottostante. Possiamo inviarti i pezzi di fissaggio solamente per mezzo di questo procedimento. Qualora dovessi avere qualche altra reclamazione in merito al mobile, allora Vi preghiamo di rivolgervi direttamente al Vostro Negozio di mobili.

Нашата директна услуга за обкова

Ако липсва част от комплекта, попълнете настоящата сервисна карта и ни я изпратете на e-mail адреса, посочен по-долу. По този начин можем да доставяме само липсващи елементи от обкова. Ако установите други дефекти по мебелите, Ви съветваме да се обърнете към мебелната къща/магазин, от който сте закупили стоката.

Onze directservice voor losse onderdelen

Wanneer er een onderdeel ontbreekt, kunt u deze servicekaart direct aan onderstaand e-mailadres sturen. Wij kunnen langs deze weg echter alleen beslagdelen versturen. Mocht u een ander probleem aan uw meubel hebben, verzoeken wij u contact op te nemen met uw meubeldealer.

Nasz bezpośredni serwis części montażowych

Jeżeli brakuje części koniecznych do montażu, prosimy o przesłanie nam niniejszej karty serwisowej na niżej podany adres e-mailowy. W ten sposób możemy przesłać Państwu tylko brakujące części. W przypadku innych reklamacji dotyczących mebla, prosimy zgłosić się do salonu meblowego, w którym został dokonany zakup.

Служба за окова

У случају да недостаје неки од дијелова молимо вас да на доле наведени mail адресу пошаљете овај сервисни образац. На овај начин могу се доставити само окови. У случају да имате додатне приговоре везане уз комад намјештаја молимо вас да се обратите изравно трговини намјештаја гдје је и исти купљен.

Direktazordíjatunk vaszalatok esetén

Ha hiányzik egy vasalat, azt a kártyát közvetlenül elküldheti az alább látható címre. Azonban csak vasalatokat tudunk így küldeni. Amennyiben másfajta reklamációt áll fenn bűtördarabjét illetően, forduljon közvetlenül a bűtörházhhoz.

Náš priamy servis pro částí kování

Ak by Vám chýbala nejaká časť kování, môžete poslať túto servisnú kartu pošťou e-mailom na nižšie uvedenú adresu. Diely kování vieme poslať iba týmto spôsobom. Ak by ste mali inú reklamáciu ohľadom Vášho nábytku, obráťte sa priamo na Vašu predajňu nábytku.

Naše direktne uslužne storive za okovje

Če vam manjka kakšno okovje, lahko to servišno kartico pošljete po e-pošti direktno na spodnji naslov. Po tej poti vam lahko pošljemo samo okovje. Če želite reklamirati kakšno drug del pohištva, se obrnite neposredno na vašo trgovino pohištva.

Services-ul nostru direct pentru fieronerie

În cazul în care vă lipsește o piesă de fieronerie puteți să trimiteți direct această card de service prin e-mail la adresa de mai jos. Noi nu putem expedia piese de fieronerie decât pe această cale. Dacă aveți o altă reclamație referitoare la piesa de mobilier, atunci vă rugăm să vă adresați direct la magazinul dvs. de mobilă.

Наш прямой сервис для поставок фурнитуры

Если окажется, что Вам не хватает той или иного элемента фурнитуры, Вы можете отправить сервисную карту по факсу непосредственно на нижеприведенный адрес электронной почты. Однако, таким образом мы можем пересылать лишь фурнитуру. Если же у Вас возникнут иные претензии относительно приобретенной мебели, пожалуйста, обращайтесь непосредственно в организацию, осуществившую продажу.

Vår direktservice för beslagdelar

Om du saknar en beslagdel kan du skicka detta servicekort direkt till e-postadressen som anges nedan. Tänk på att detta är den enda möjligheten att skicka beslagdelar till dig. Om du vill reklamera din möbel av en annan anledning måste du kontakta ditt möbelhus direkt.

Nuestro servicio directo para accesorios

Si le falta algún accesorio, puede enviar esta tarjeta de servicio directamente a la siguiente dirección. No obstante, por este método solo podemos enviar accesorios. Si tiene alguna otra objeción sobre su mueble, consulte directamente con su mueblería.

Donatılar için doğrudan servisimiz

Bir donatınız eksikse bu servis kartını doğrudan aşağıda bulunan adrese doğrudan mail yazababilirsiniz. Sadece bu yolla donatıları gönderebilirsiniz. Mobilyanızda başka şikayetleriniz varsa lütfen doğrudan mobilya satıcınıza danışın.

nr	L[mm]	B[mm]	T[mm]	Menge	Coil
1	400	450	16	1	1/1
2	355	411	16	1	1/1
3	355	373	16	1	1/1
4	355	411	16	1	1/1
5	400	450	16	1	1/1
6	1368	416	16	1	1/1
7	1368	412	16	1	1/1
8	1368	80	16	1	1/1
9	886	77	38	1	1/1
10	900	85	16	1	1/1
11	397	228	16	2	1/1

nr	L[mm]	B[mm]	T[mm]	Menge	Coil
12	900	258	16	1	1/1
13	350	120	12	2	1/1
14	350	120	12	2	1/1
15	402	105	12	2	1/1
16	412	358	3	2	1/1
17	371	688	3	1	1/1
18	371	688	3	1	1/1

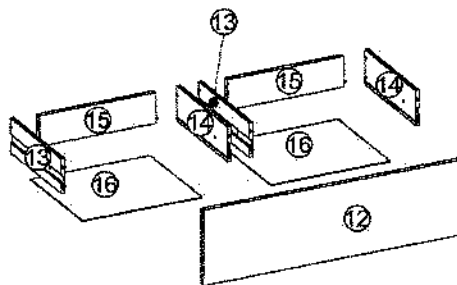
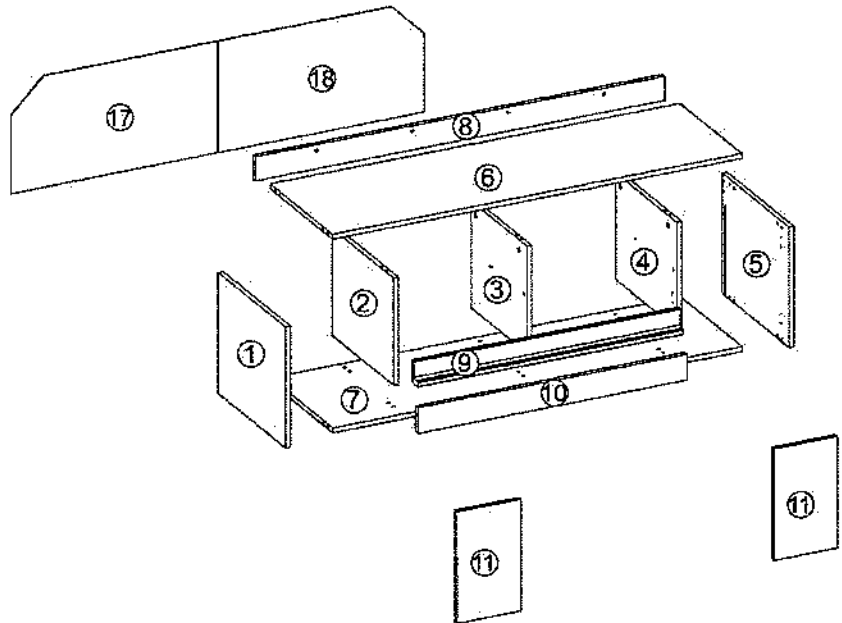

D
GB
CZ
F
I
BG
NL
PL
HR
HU
SK
SLO
RO
RUS
S
ES
TR

Modell: CITY / GIRON 56

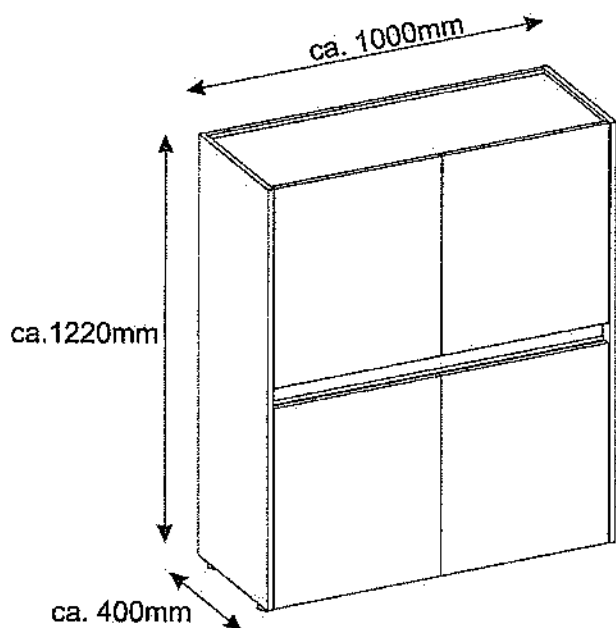

- Ⓓ Montageanleitung
- Ⓐ Handleiding voor de montage
- Ⓓ Montaj talimatı
- Ⓕ Notice de montage
- Ⓒ Montážní návod
- Ⓗ Szereelési útmutató
- Ⓒ Assembly Instructions
- Ⓐ Instrukcja montażu
- Ⓔ Инструкция по монтажу
- Ⓘ Istruzioni di montaggio
- Ⓐ Návod na montáž
- Ⓓ Instrucțiuni de montaj
- Ⓔ Instrucciones de montaje
- Ⓓ Montaj Talimatı

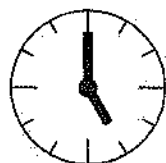
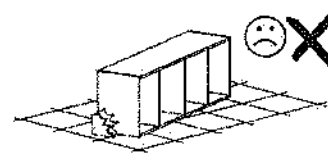
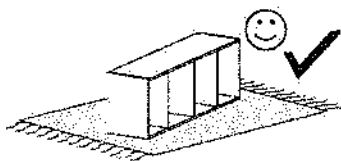
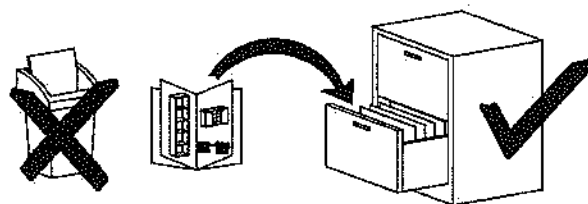
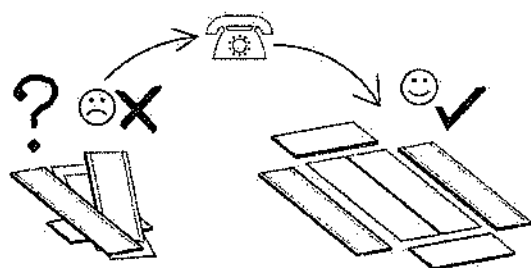
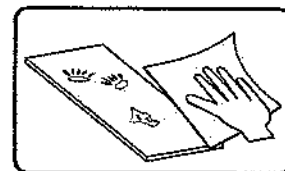
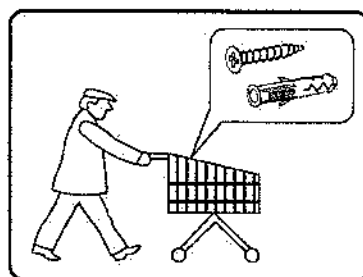
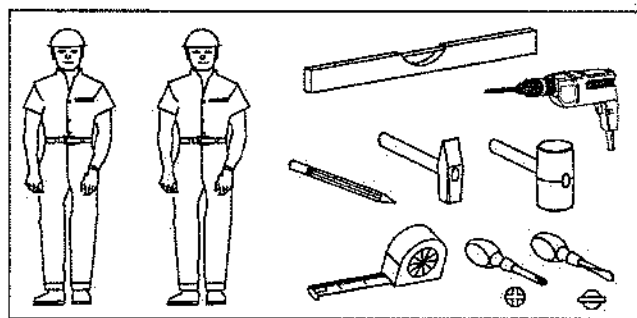

2,5h

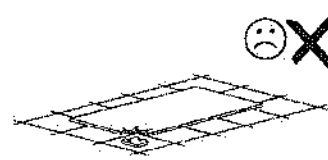
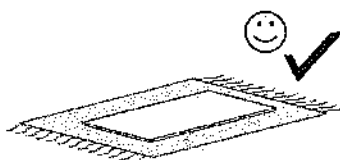

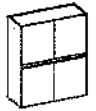



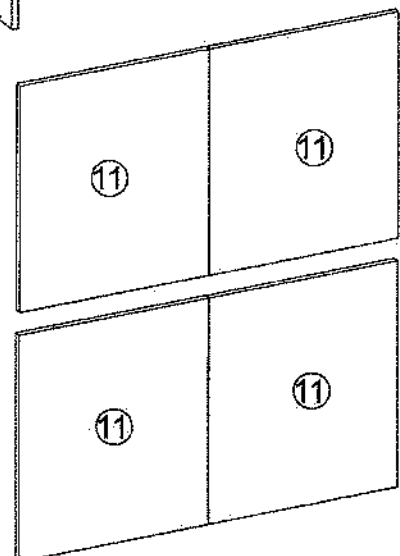
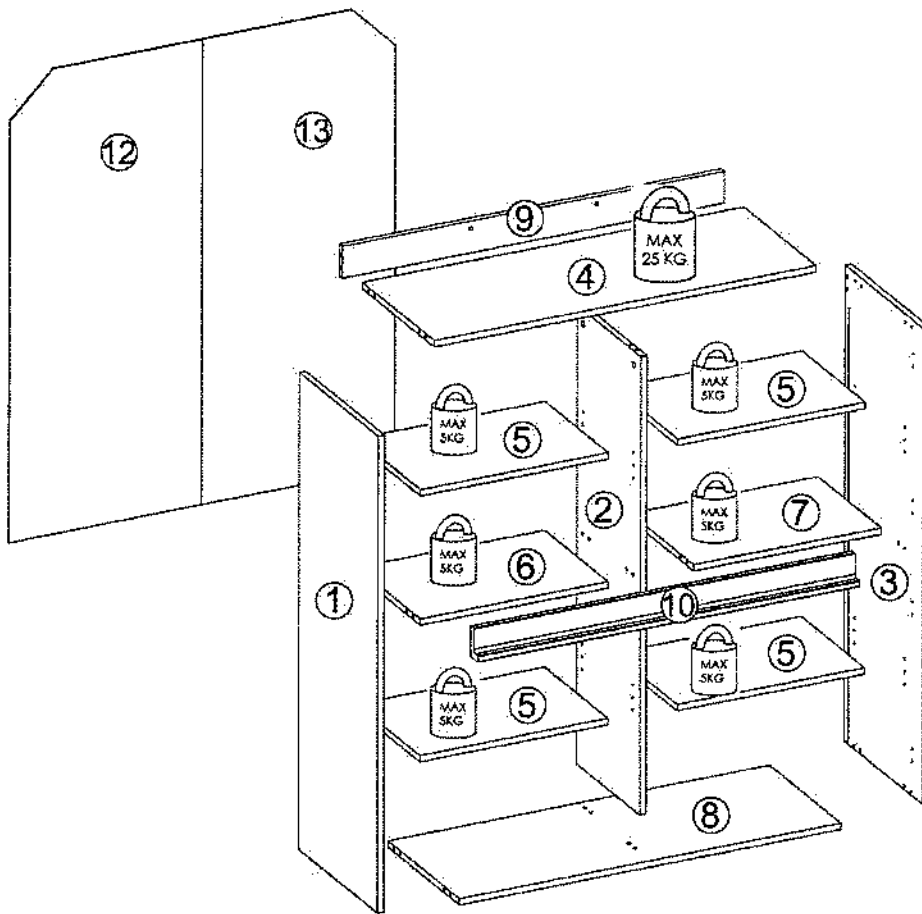

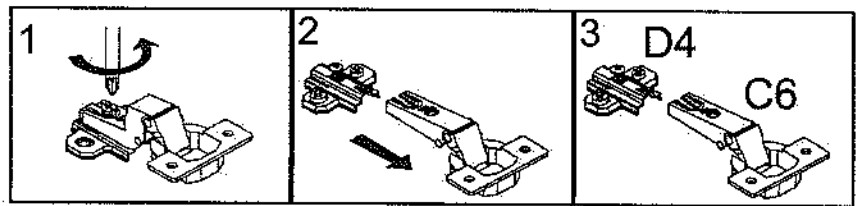
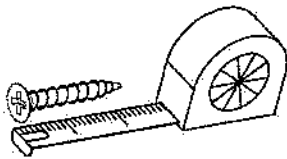
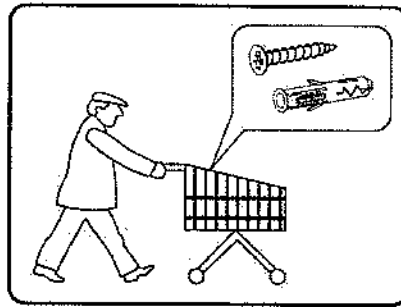











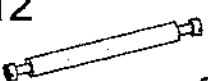

n°	L[mm]	B[mm]	T[mm]	Menge	Coll
1	1200	400	16	1	2/2
2	1155	323	16	1	2/2
3	1200	400	16	1	2/2
4	968	366	16	1	1/2
5	476	322	16	4	1/2
6	476	322	16	1	1/2
7	476	322	16	1	1/2
8	968	362	16	1	1/2
9	968	80	16	1	2/2
10	968	77	38	1	2/2
11	571	480	16	4	2/2
12	1170	489	3	1	2/2
13	1170	489	3	1	2/2

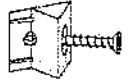

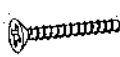

B1  ø8x35 x20	B3  ø8x60 x2	A1  ø7x50 x4	W2  x1	I7  x14
K1  x18	K10  x14	D4  x8	C6  x8	G34  3,5x16 x18
K12  x2	G49  4x16 x16	F13  x4	Z6  x8	I1  x6
F2  x16	M11  x2	G50  3x20 x20	P10  x5	G36  4x30 x5

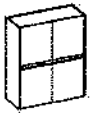

I

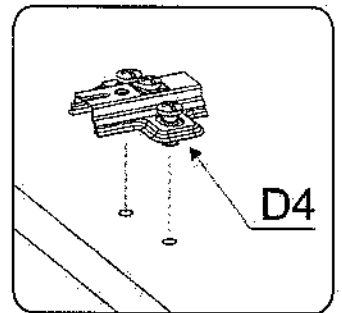
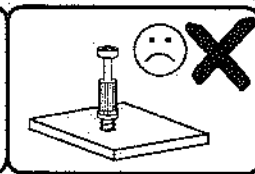
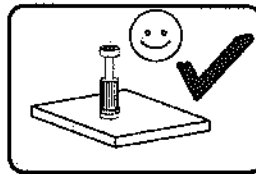
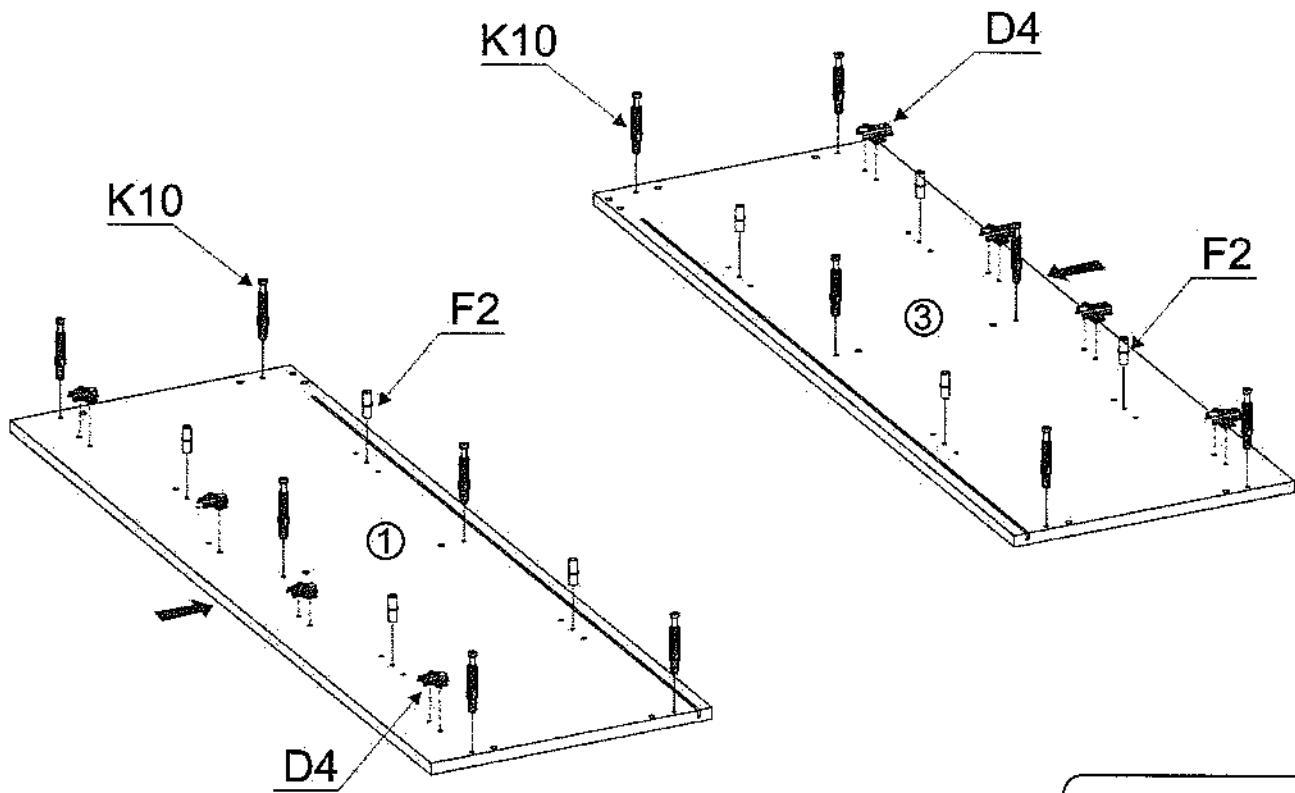
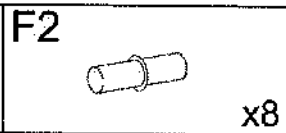
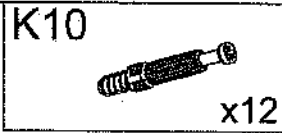

II

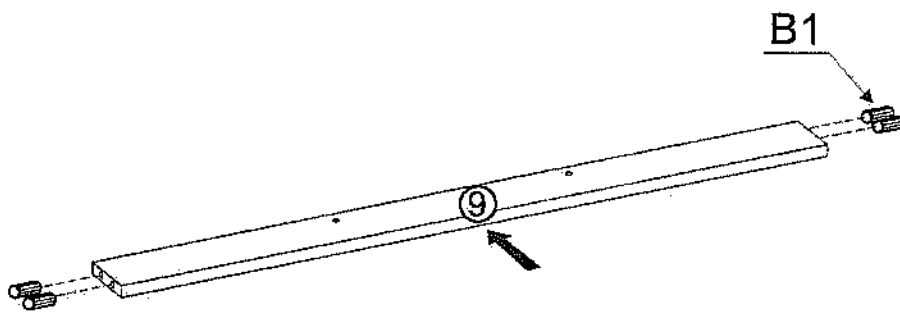
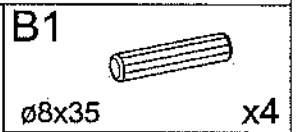

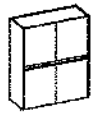

III

F2

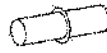

x8

B1



ø8x35

x4

K1



x2

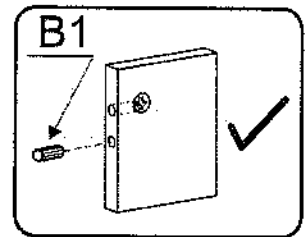
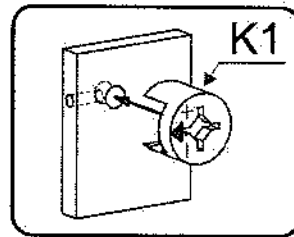
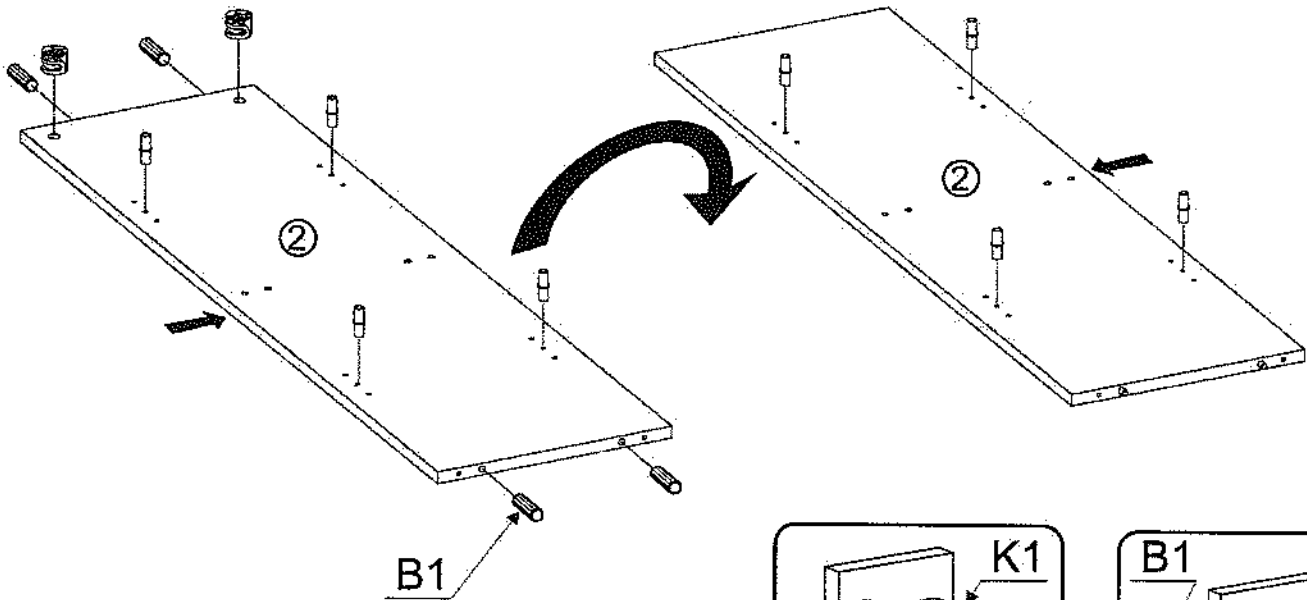

IV

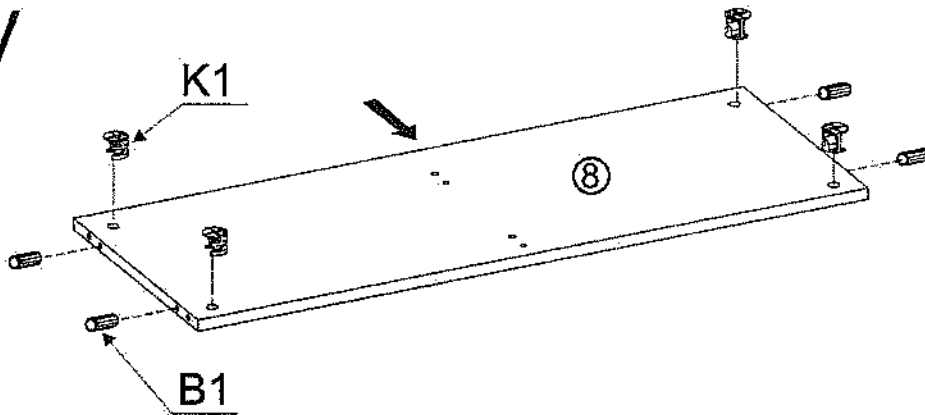

B1



ø8x35

x8

K1



x8

K10



x2

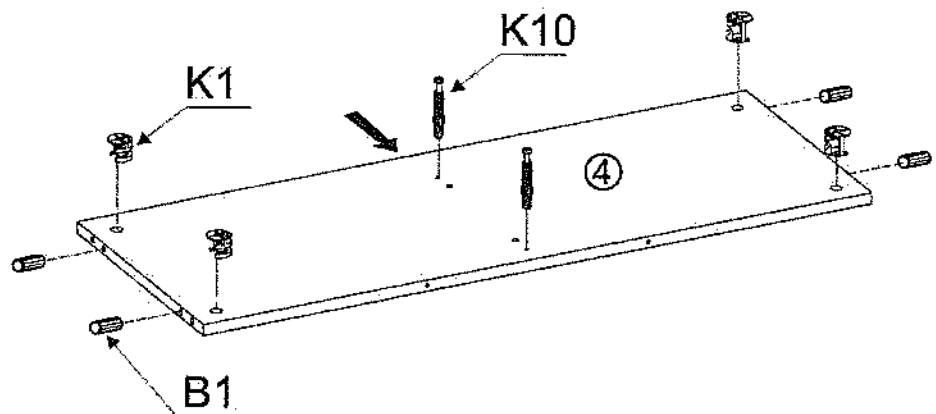

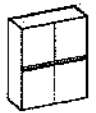

V

F13		x4	K1		x8
G49		x4	B1		x4
		4x16			ø8x35

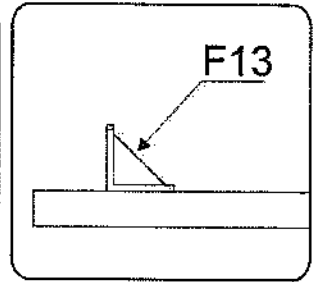
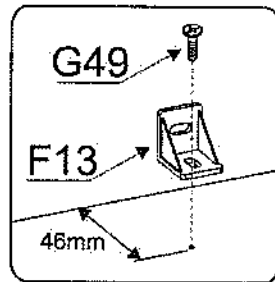
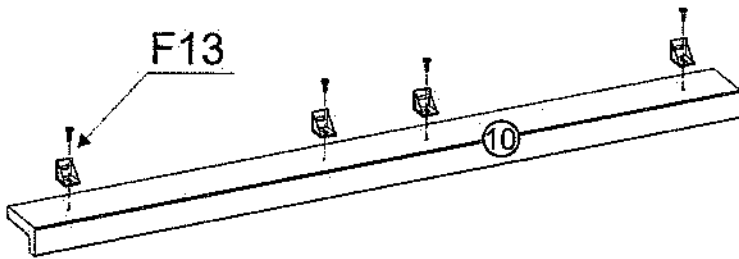
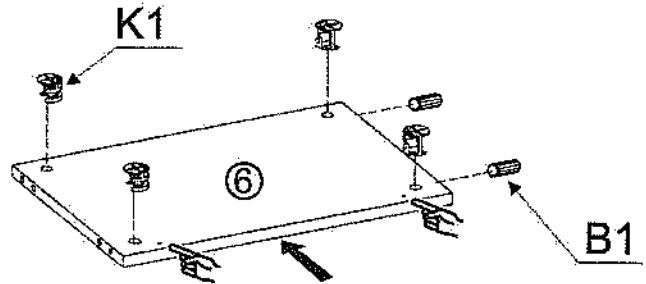
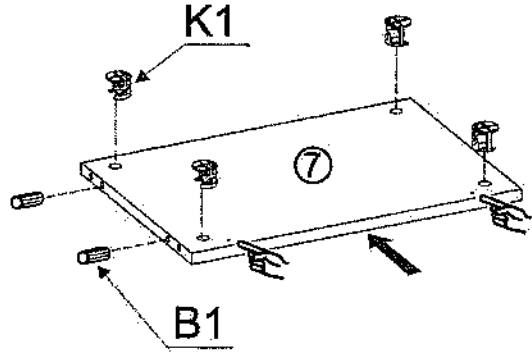

VI

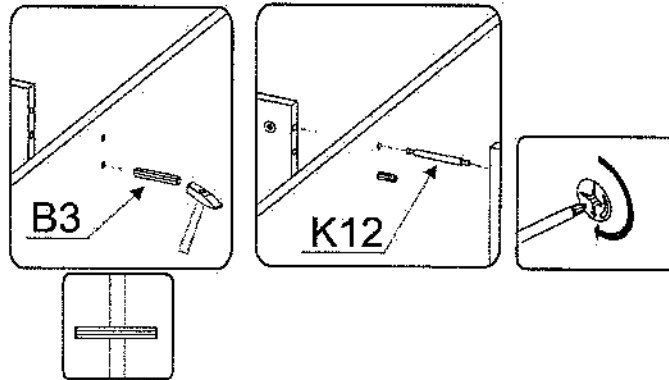

B3		x2
		ø8x60
K12		x2



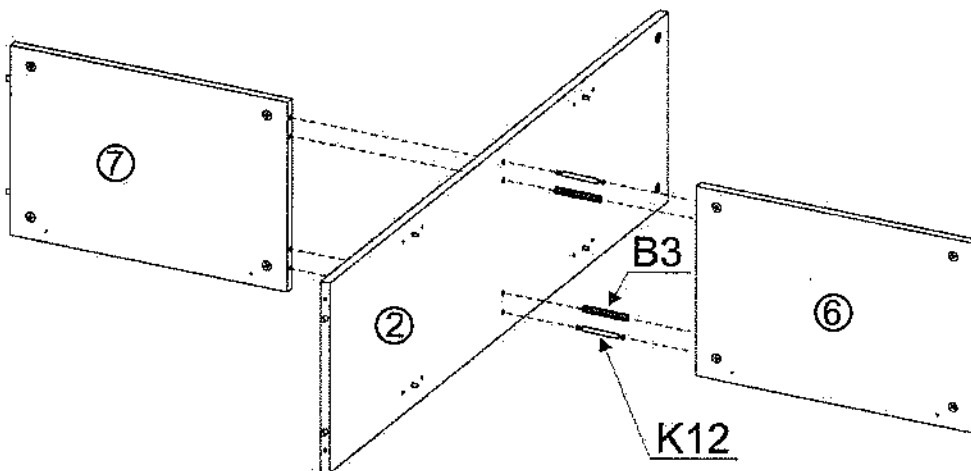

B3	
ø8x60	

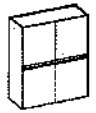

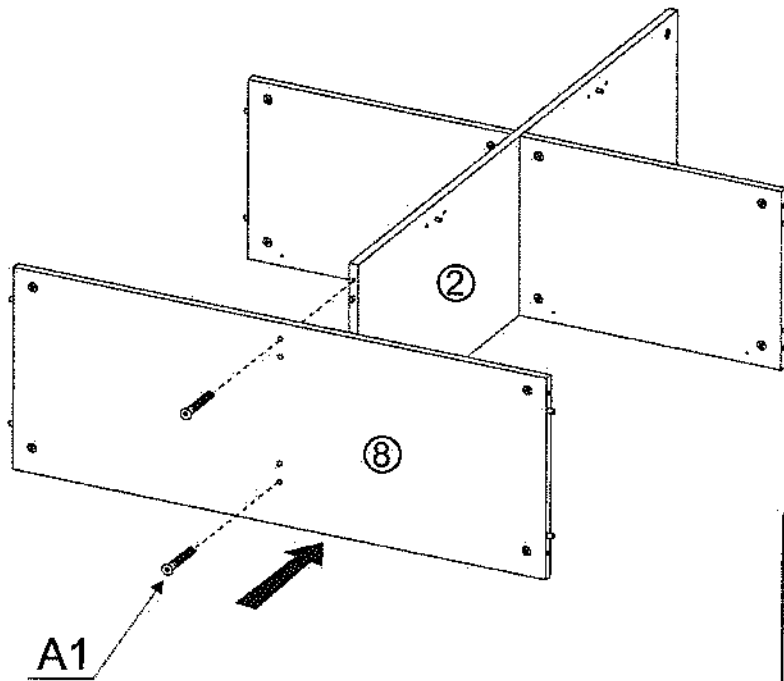

VII

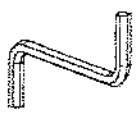

- A1  $\phi 7 \times 50$ x2
- W2  x1

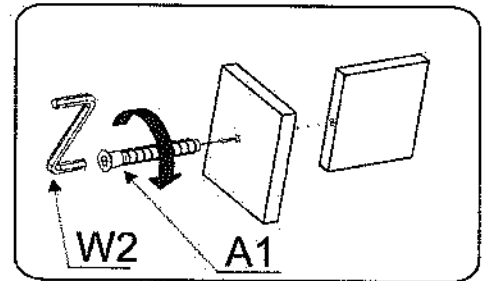

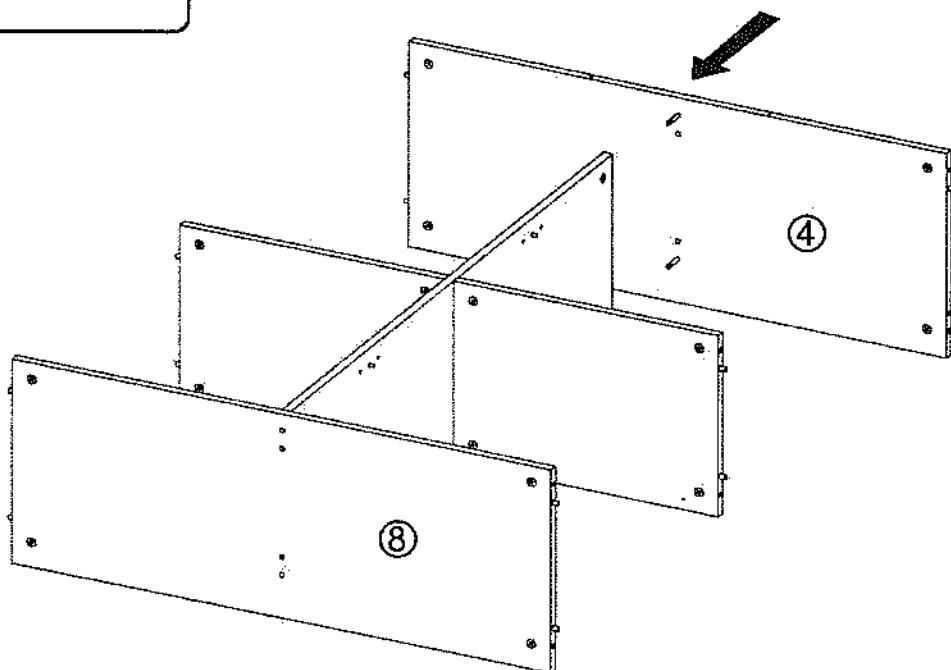
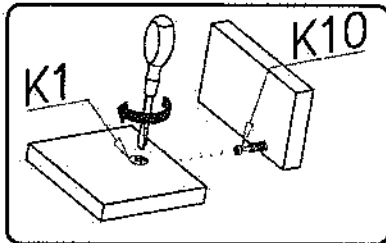

VIII



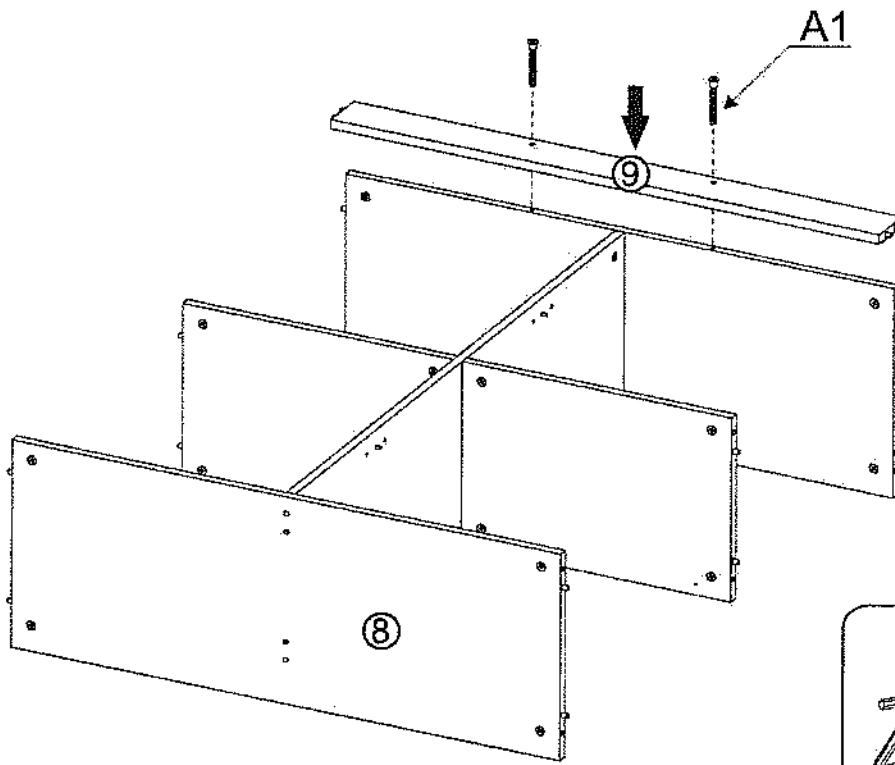

IX

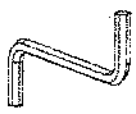

A1  x2
ø7x50

W2  x1

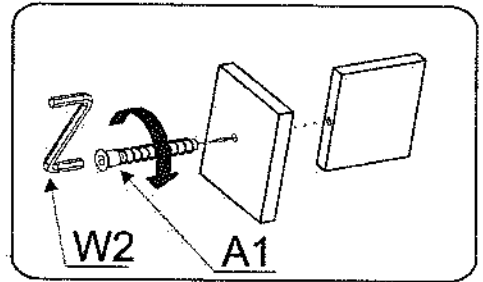
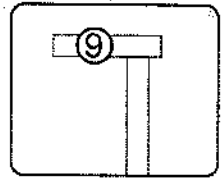

X

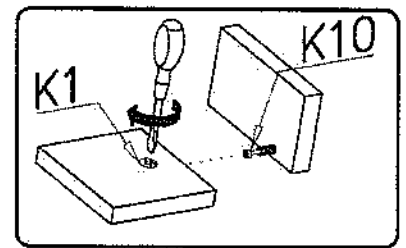
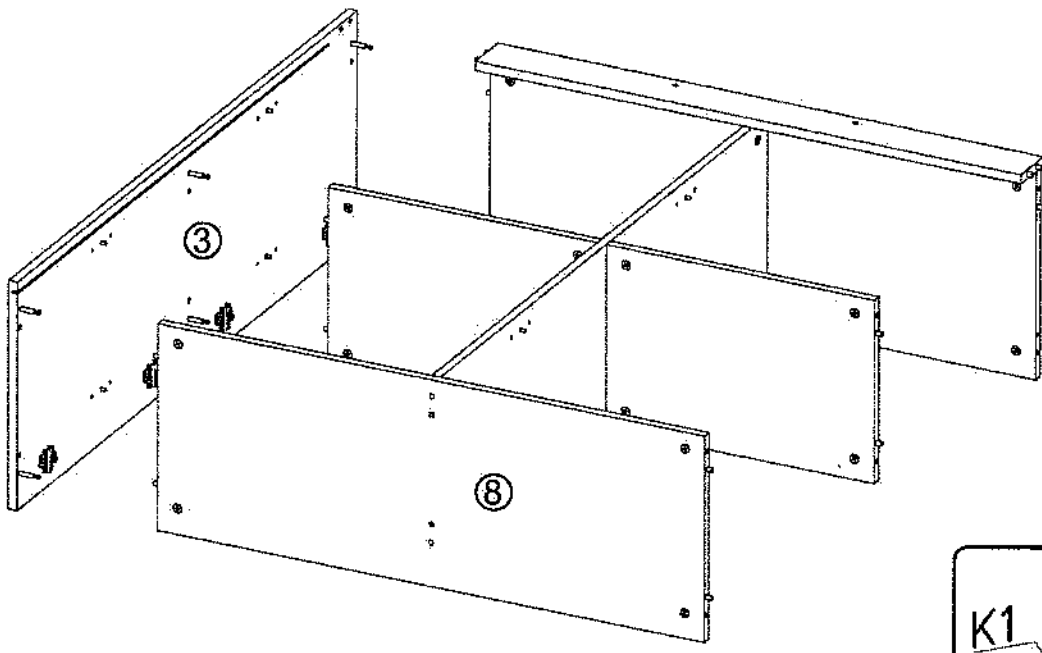

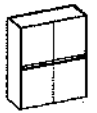

XI

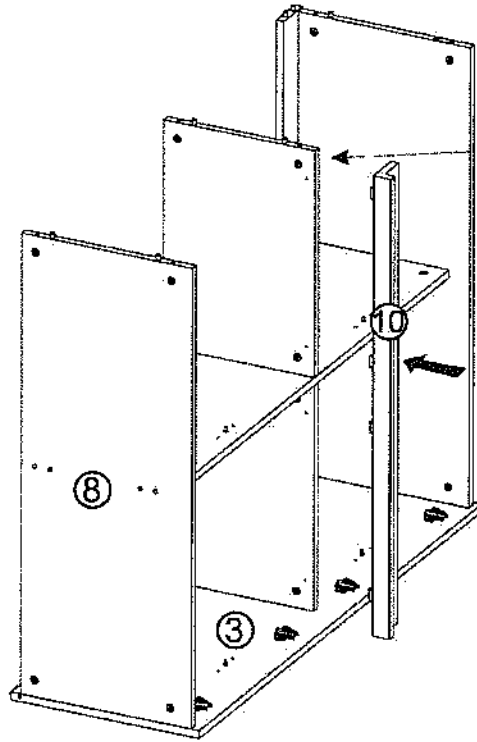
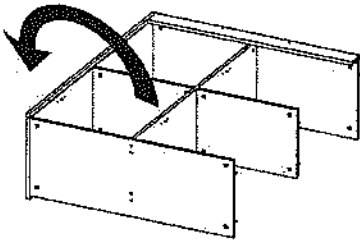

G49



4x16

x4

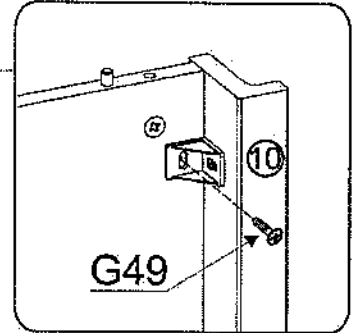

XII

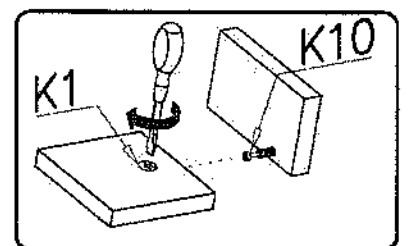
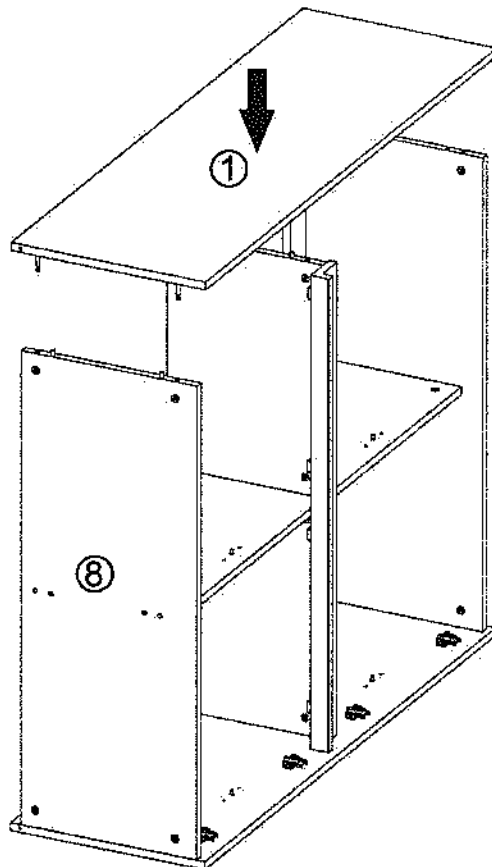

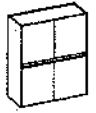

XIII

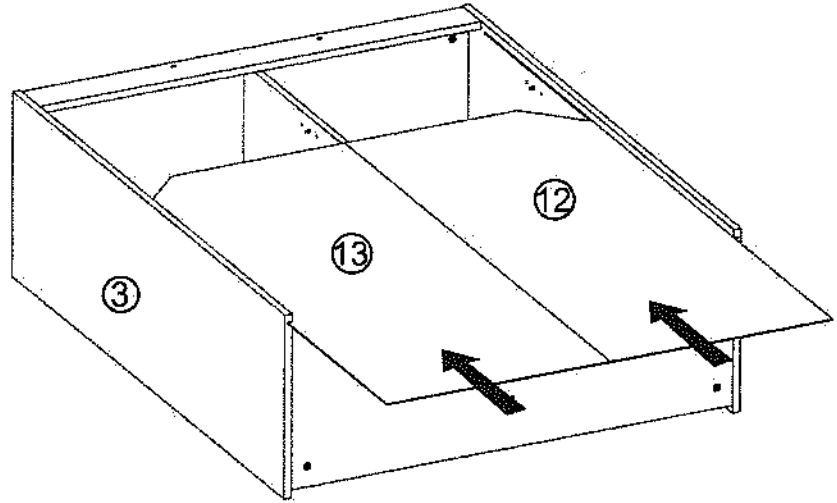
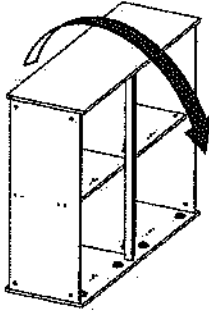

XIV

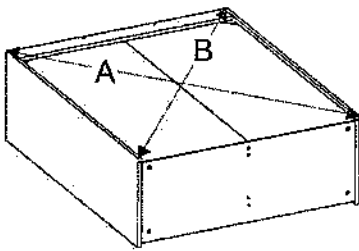

A=B

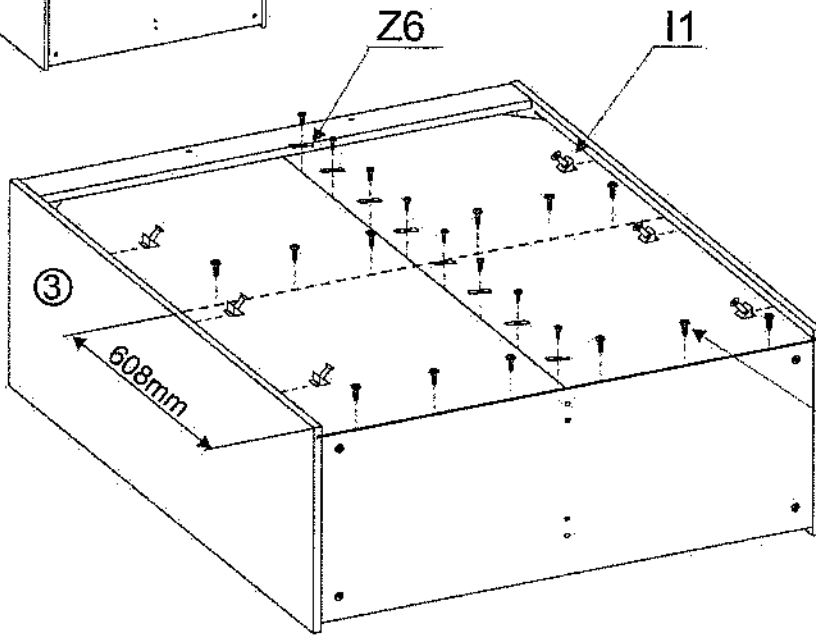

G50

3x20



x20

I1

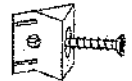

x6

Z6



x8

G50

a=b

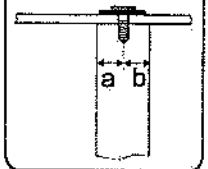

G50

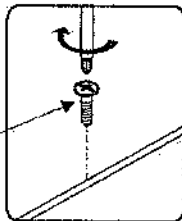

a=b

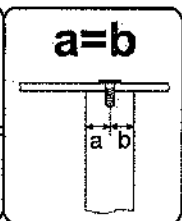

I1

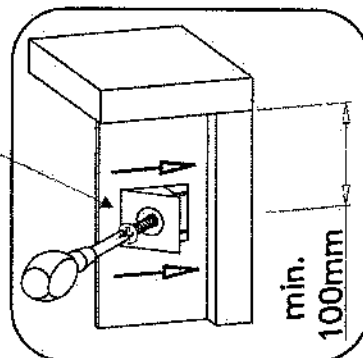

min. 100mm

G50

Z6

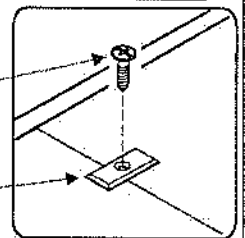

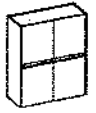

XV

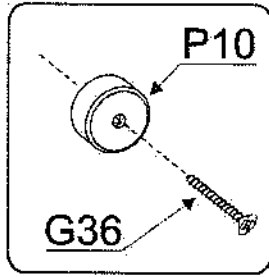

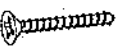
- P10  x5
- G36  4x30 x5

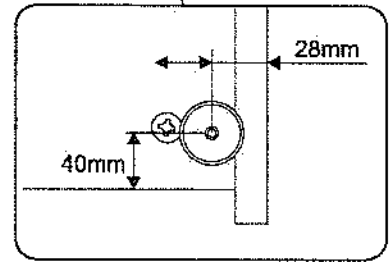
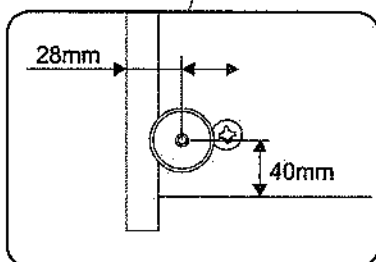
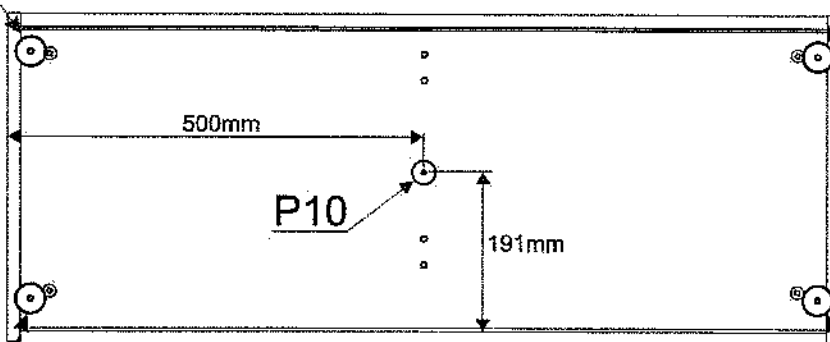
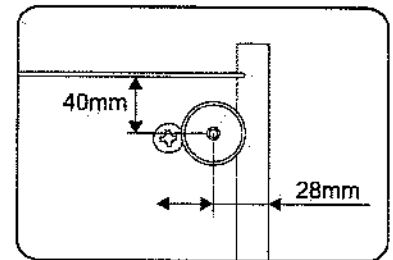
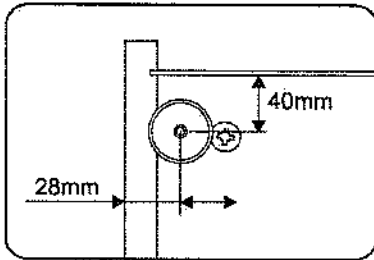
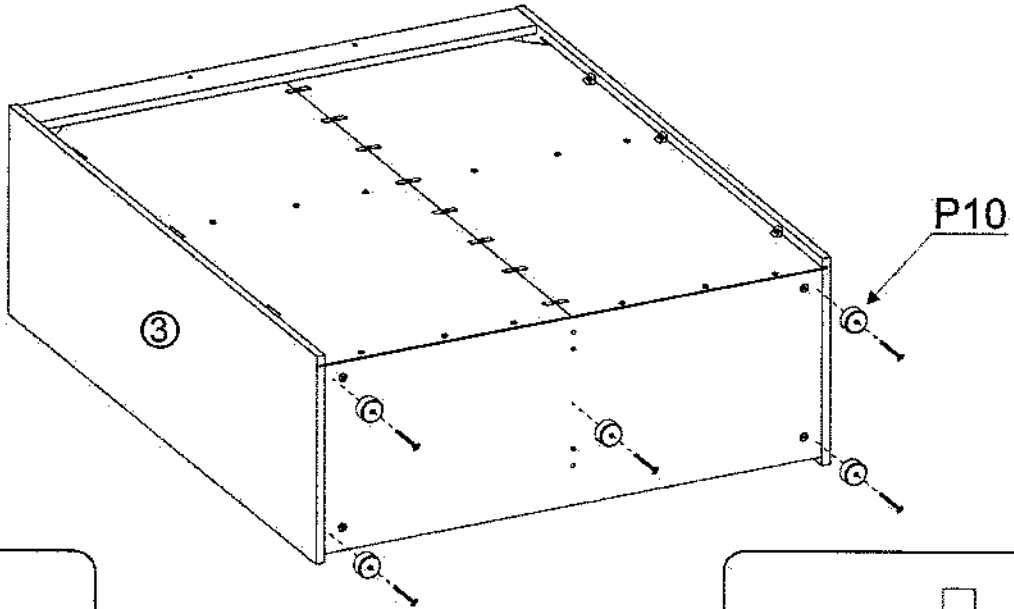

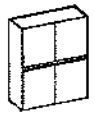

XVI

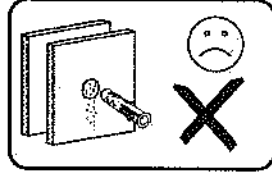
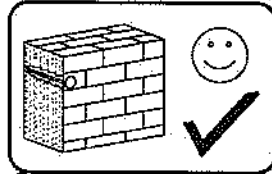
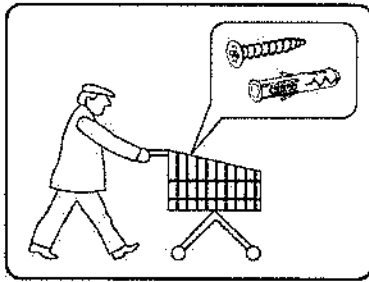

G34



3,5x16

x2

M11



x2

I7



x14

G49



4x16

x8

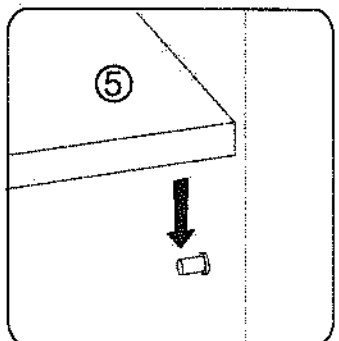
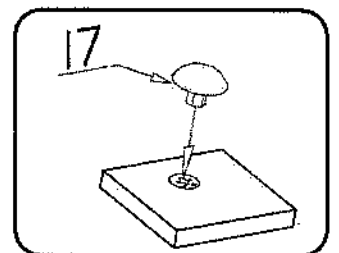
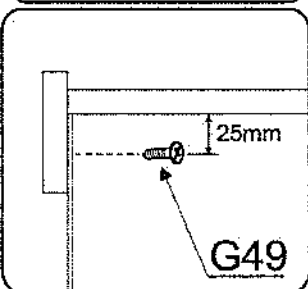
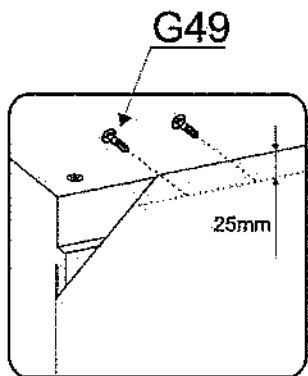
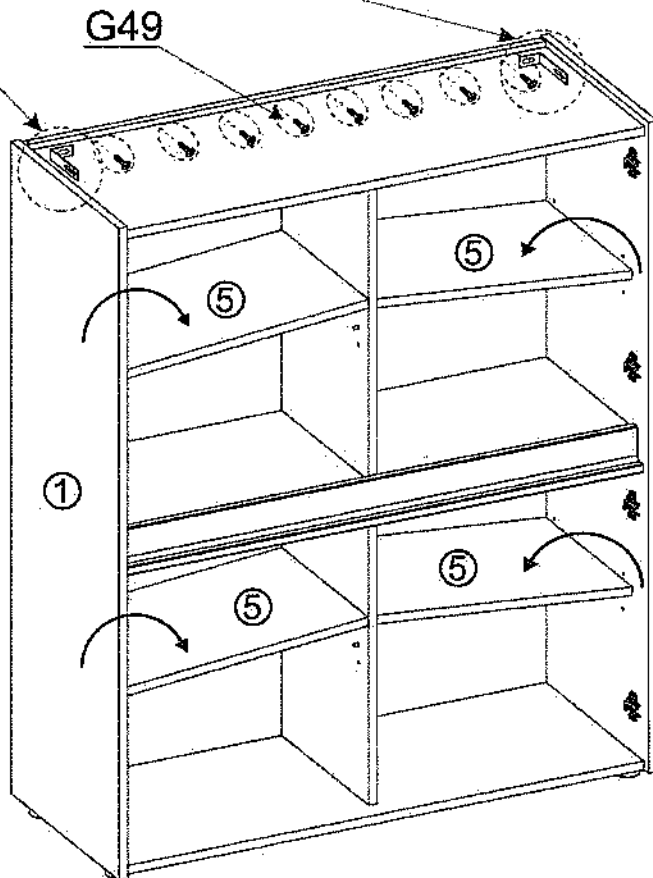
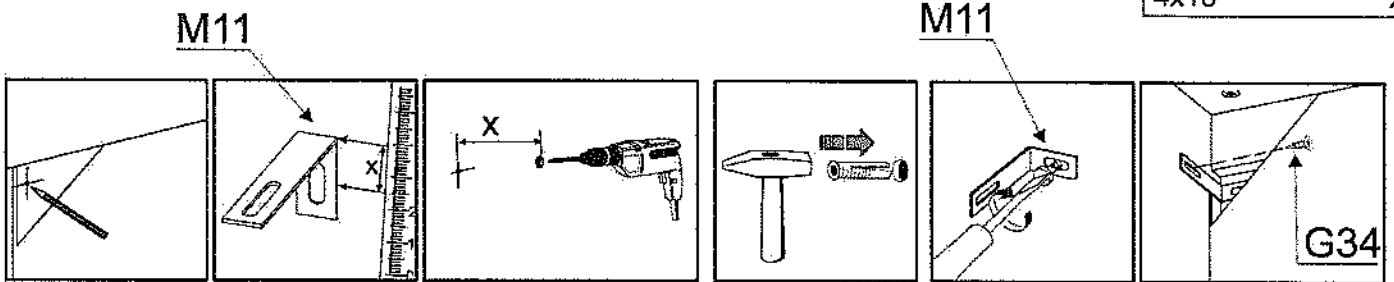

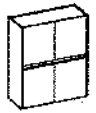

XVII

C6  x8

G34  3,5x16 x16

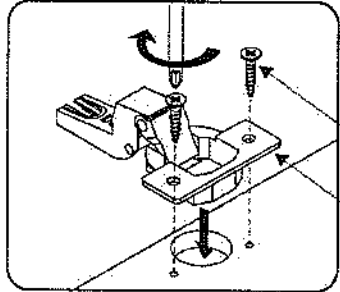

G34

C6

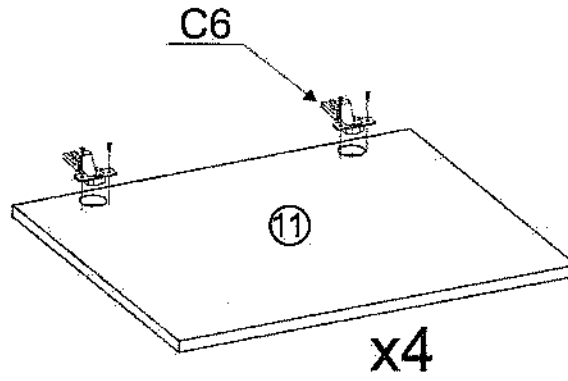

XVIII

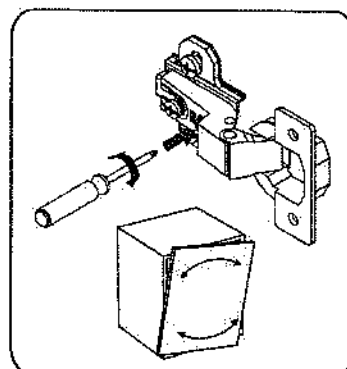
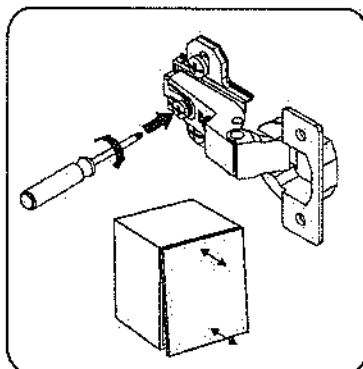
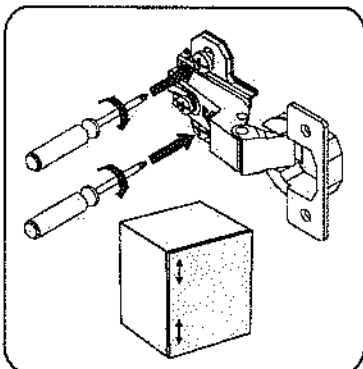
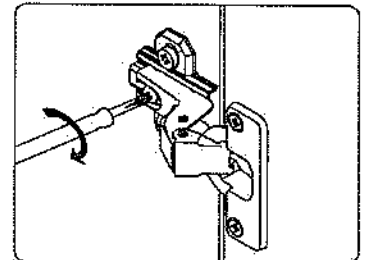
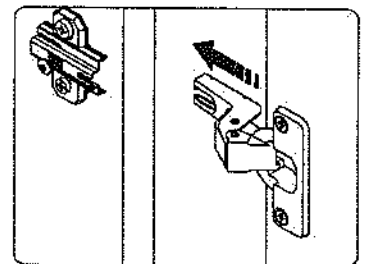
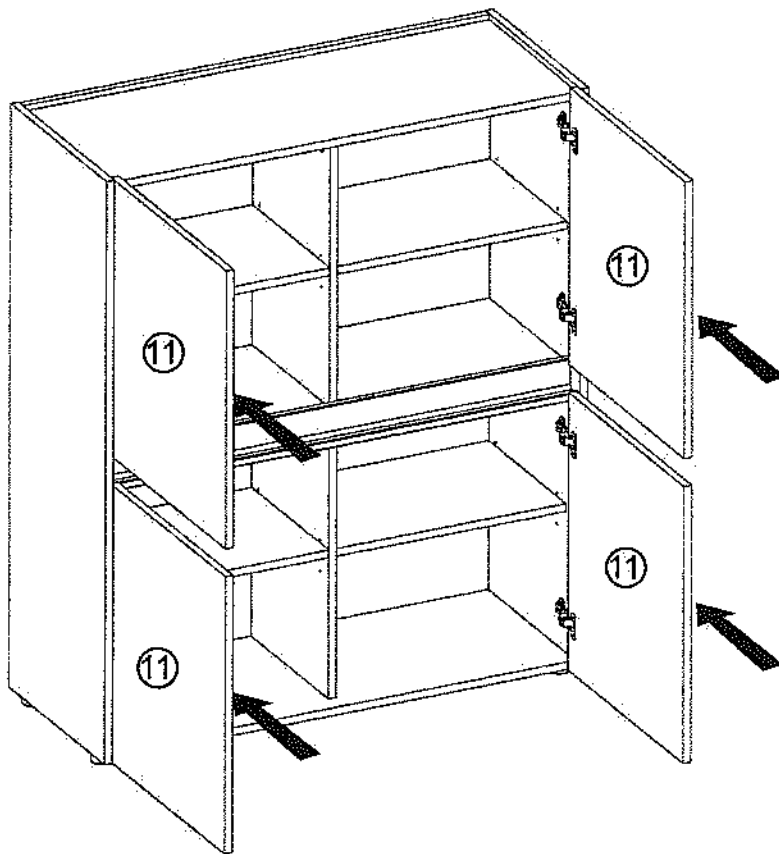

Name • Nom • Nome • Naam • Nazwa • Jméno
• Názov • Név • Denumire • İsim • Имя

Nr • No • N° • Номер • Č • Sz

Typ • Type • Tip • Típus • Tipo • Tun

CITY / GIRON

56

Unser Direktservice für Beschlagteile

Sollte Ihnen ein Beschlagteil fehlen, können Sie diese Servicekarte direkt an die untenstehende Adresse mailen. Wir können allerdings nur Beschlagteile auf diesem Wege verschicken. Sollten Sie eine andere Beanstandung an Ihrem Möbelstück haben, so wenden sie sich bitte direkt an Ihr Möbelhaus.

Our direct order service for fitting
If a fitting part is missing, you can e-mail this service card directly to the address below. However, we can only send fitting parts in this way. If you have any other cause for complaint concerning your item of furniture, please contact your furniture store directly.

Naše přímá služba pro kování

Chybí-li vám nějaký díl z kování, můžete tuto servisní kartu odeslat e-mailem přímo na níže uvedenou adresu. Toulou cestou však můžeme zaslát jen díly kování. Pokud byste reklamovali jiný díl nábytku, obraťte se přímo na svého prodejce nábytku.

Bien utiliser la notice de montage

Si vous manquez une ferrure, veuillez envoyer directement la présente carte service à l'adresse e-mail indiquée ci-dessous. Cependant, ceci nous permet uniquement d'envoyer des ferrures. Pour tout autre type de réclamation concernant votre meuble, veuillez contacter directement votre magasin d'ameublement.

Il nostro servizio diretto per i colli della ferramenta

Qualora Vi dovesse mancare un pezzo di fissaggio, allora Vi preghiamo di inviare questa carta di servizio immediatamente all'indirizzo sottostante. Possiamo inviare i pezzi di fissaggio solamente per mezzo di questo procedimento. Qualora dovete avere qualche altra reclamazione in merito al mobile, allora Vi preghiamo di rivolgerVi direttamente al Vostro Negozio di mobili.

Наша директна услуга за обкова

Ако липсваат части од комплетот, попълнете настоящата сервисна карта и ни ја испратете на е-маил адреса, посочен подолу. По тој начин можеме да доставиме само липсваши елементи од обкова. Ако установите други дефекти по мебелите, Ви советуваме да се обратите към мебелната къща/магазин, от който сте закупили стоката.

Onze directservice voor losse onderdelen

Wanneer er een onderdeel ontbreekt, kunt u deze servicekaart direct aan onderstaand e-mailadres sturen. Wij kunnen langa deze weg echter alleen beslagdelen verzuren. Mocht u een ander probleem aan uw meubel hebben, verzoeken wij u contact op te nemen met uw meubeldealer.

Nasz bezpośredni serwis części montażowych

Jeżeli brakuje części koniecznych do montażu, prosimy o przesłanie nam niniejszej karty serwisowej na niżej podany adres e-mailowy. W ten sposób możemy przelać Państwu tylko brakujące części. W przypadku innych reklamacji dotyczących mebla, prosimy zgłosić się do salonu meblowego, w którym został dokonany zakup.

Service za okova

U slučaju da nedostaju neki od dijelova, molimo vas da na doleja navedenu mail adresu pošaljete ovaj servisni obrazac. Na ovaj način mogu se dostaviti samo okovi. U slučaju da imate dodatne prigovore vezane uz komad namještaja molimo vas da se obratite izravno trgovini namještaja gdje je isti kupljen.

Direktzoldólatunk vasalatok esetén

Ha hiányzik egy vasalat, ezt a kártyát közvetlenül elküldheti az alább található címre. Azonban csak vasalatokkal tudunk így küldeni. Amennyiben másfajta reklamáció áll fenn bútoráruházt illetően, forduljon közvetlenül a bútoráruházhoz.

Náš priamy servis pre časti kovania

Ak by Vám chýbala nejaká časť kovania, môžete poslať túto servisnú kartu poslať e-mailom na nižšie uvedenú adresu. Diely kovania vieme poslať iba týmto spôsobom. Ak by ste mali inú reklamáciu ohľadom Vašho nábytku, obráťte sa priamo na Vašu predajňu nábytku.

Naše direktno uslužne storive za okovje

Če vam manjka kakšno okovje, lahko to servisno kartico pošljete po e-pošti direktno na spodnji naslov. Po tej poti vam lahko pošljemo samo okovje. Če želite reklamirati kakšen drug del pohištva, se obrnite neposredno na vaše trgovino pohištva.

Service-ul nostru direct pentru feronerie

În cazul în care vă lipsește o piesă de feronerie puteți să trimiteți direct această card de service prin e-mail la adresa de mai jos. Noi nu putem expedia piese de feronerie decât pe această cale. Dacă aveți o altă reclamație referitoare la piesa de mobilier, atunci vă rugăm să vă adresați direct la magazinul dvs. de mobilă.

Наш прямой сервис для поставок фурнитуры

Если окажется, что Вам не хватает того или иного элемента фурнитуры, Вы можете отправить сервисную карту по факсу непосредственно на нижеприведенный адрес электронной почты. Однако, таким образом мы можем пересылать лишь фурнитуру. Если же у Вас возникнут иные претензии относительно приобретенной мебели, пожалуйста, обращайтесь непосредственно в организацию, осуществляющую продажу.

Vår direktservice för beslagdelar

Om du saknar en beslagdel kan du skicka detta servicekort direkt till e-postadressen som anges nedan. Tank på att detta är den enda möjligheten att skicka beslagdelar till dig. Om du vill reklamera din möbel av en annan anledning måste du kontakta ditt möbelhus direkt.

Nuestro servicio directo para accesorios

Si le falta algún accesorio, puede enviar esta tarjeta de servicio directamente a la siguiente dirección. No obstante, por este método solo podemos enviar accesorios. Si tiene alguna otra objeción sobre su mueble, consulte directamente con su mueblería.

Donatjar kin doordien servismiz

Br donatjar eksikse bu servis kartini dogrudan aşagida bulunan adrese dogrudan mail yazabilirsiniz. Sadece bu yolla donatıları gönderebilirsiniz. Mobilyanızda başka şikayetleriniz varsa lütfen dogrudan mobilya satıcınıza danışın.

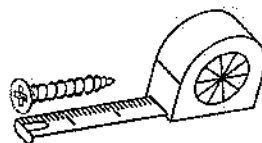

B1 ø8x35 X...	B3 ø8x60 X...	A1 ø7x50 X...
W2	I7	K1
K10	D4	C6
G34 3,5x16 X...	K12	G49 4x16 X...
F13	Z6	I1
F2	M11	G50 3x20 X...
P10	G36 4x30 X...	

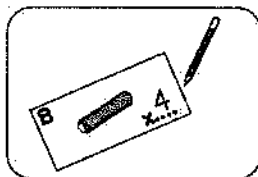

Name • Nom • Nome • Naam • Nazwa • Jméno
• Νόμος • Νέμ • Denumire • İsim • Название

Nr • No • N • Номер • Č • Sz

Typ • Type • Tip • Τύπος • Tipo • Tun

CITY / GIRON

--

56

D Unser Direktservice für Beschlagteile

Sollte Ihnen ein Beschlagteil fehlen, können Sie diese Servicekarte direkt an die untenstehende Adresse mailen. Wir können allerdings nur Beschlagteile auf diesem Wege verschicken. Sollten Sie eine andere Beanstandung an Ihrem Möbelstück haben, so wenden sie sich bitte direkt an Ihr Möbelhaus.

GB Our direct order service for fitting
If a fitting part is missing, you can e-mail this service card directly to the address below. However, we can only send fitting parts in this way. If you have any other cause for complaint concerning your item of furniture, please contact your furniture store directly.

CZ Naše přímé služby pro kování

Chybí-li vám nějaký díl z kování, můžete tuto servisní kartu odeslat e-mailem přímo na níže uvedenou adresu. Touto cestou však můžeme zoslat jen díly kování. Pokud byste reklamovali jiný díl nábytku, obraťte se přímo na svého prodejce nábytku.

F Bien servir la notice de montage

Si il vous manque une ferrure, veuillez envoyer directement la présente carte service à l'adresse e-mail indiquée ci-dessous. Cependant, ceci nous permet uniquement d'envoyer des ferrures. Pour tout autre type de réclamation concernant votre meuble, veuillez contacter directement votre magasin d'ameublement.

I Il nostro servizio diretto per l'ordine della ferramenta

Qualora Vi dovesse mancare un pezzo di fissaggio, allora Vi preghiamo di inviare questa carta di servizio immediatamente all'indirizzo sottostante. Possiamo inviare i pezzi di fissaggio solamente per mezzo di questo procedimento. Qualora dovete avere qualche altra reclamazione in merito al mobile, allora Vi preghiamo di rivolgerVi direttamente al Vostro Negozio di mobili.

BG Нашата директна услуга за обкова

Ако липсват части от комплекта, попълнете настоящата сервисна карта и ни я изпратете на е-мал адрес, посочен по-долу. По този начин можем да доставяме само липсващи елементи от обкова. Ако установите други дефекти по мебелите, Ви съветваме да се обърнете към мебелната къща/магазин, от който сте закупили стоката.

NL Onze directservice voor lasse onderdelen

Wanneer er een onderdeel ontbreekt, kunt u deze servicekaart direct aan onderstaand e-mailadres sturen. Wij kunnen langs deze weg echter alleen beslagdelen verzuren. Mocht u een ander probleem aan uw meubel hebben, verzoeken wij u contact op te nemen met uw meubeldealer.

PL Nasz bezpośredni serwis części montażowych

Jeżeli brakuje części koniecznych do montażu, prosimy o przesłanie nam niniejszej karty serwisowej na niżej podany adres e-mailowy. W ten sposób możemy przelać Państwu tylko brakujące części. W przypadku innych reklamacji dotyczących mebla, prosimy zgłaszać się do salonu meblowego, w którym został dokonany zakup.

HR Servis za okove

U slučaju da nedostaje neki od dijelova molimo vas da na doje navedenu mail adresu pošaljete ovaj servisni obrazac. Na ovaj način mogu se dostaviti samo okovi. U slučaju da imate dodatne prigovora vezane uz komad namještaja molimo vas da se obratite izravno trgovini namještaja gdje je isti kupljen.

HU Direktszolgáltatunk vasalatók esztén

Ha hiányzik egy vasalat, azt a kártyát közvetlenül elküldheti az alább található címre. Azonban csak vasalatókat tudunk így küldeni. Amennyiben másféle reklamáció áll fenn bútorárbaját illetően, forduljon közvetlenül a bútormáshoz.

SK Naš priamy servis pre časti kovania

Ak by Vám chýbala nejaká časť kovania, môžete poslať túto servisnú kartu pošťou e-mailom na nižšie uvedenú adresu. Diely kovania vieme poslať iba týmto spôsobom. Ak by ste mali inú reklamáciu ohľadom Vášho nábytku, obraťte sa priamo na Vašu predajňu nábytku.

SLO Naše direktna uslužna storitva za okovje

Če vam manjka kakšno okovje, lahko to serviso kartico pošljete po e-pošti direktno na spodnji naslov. Po tej poti vam lahko pošljemo samo okovje. Če želite reklamirati kakšen drug del pohštva, se obrnite neposredno na vašo trgovino pohštva.

RO Service-ul nostru direct pentru feronerie

În cazul în care vă lipsește o piesă de feronerie puteți să trimiteți direct acest card de service prin e-mail la adresa de mai jos. Noi nu putem expedia piese de feronerie decât pe această cale. Dacă aveți o altă reclamație referitoare la piesa de mobilier, atunci vă rugăm să vă adresați direct la magazinul dvs. de mobilă.

RUS Наш прямой сервис для поставок фурнитуры

Если ожидается, что Вам не хватает того или иного элемента фурнитуры, Вы можете отправить сервисную карту по факсу непосредственно на нижеприведенный адрес электронной почты. Однако, таким образом мы можем пересылать лишь фурнитуру. Если же у Вас возникнут иные претензии относительно приобретенной мебели, пожалуйста, обращайтесь непосредственно в организацию, осуществляющую продажу.

S Vår direktservice för beslagdelar

Om du saknar en beslagdel kan du skicka detta servicekort direkt till e-postadressen som anges nedan. Tänk på att detta är den enda möjligheten att skicka beslagdelar till dig. Om du vill reklamera din möbel av en annan anledning måste du kontakta ditt möbelhus direkt.

ES Nuestro servicio directo para accesorios

Si le falta algún accesorio, puede enviar esta tarjeta de servicio directamente a la siguiente dirección. No obstante, por este método solo podemos enviar accesorios. Si tiene alguna otra objeción sobre su mueble, consulte directamente con su mueblería.

TR Donatılar için doğrudan servisimiz

Bir donatınız eksikse bu servis kartını doğrudan aşağıda bulunan adrese doğrudan mail yazabilirsiniz. Sadece bu yolla donatılar gönderiliriz. Mobilyanızda başka şikayetleriniz varsa lütfen doğrudan mobilya satışçınıza danışın.

nr	L[mm]	B[mm]	T[mm]	Menge	Coll
1	1200	400	16	1	2/2
2	1155	323	16	1	2/2
3	1200	400	16	1	2/2
4	968	366	16	1	1/2
5	476	322	16	4	1/2
6	476	322	16	1	1/2
7	476	322	16	1	1/2
8	968	362	16	1	1/2
9	968	80	16	1	2/2
10	968	77	38	1	2/2
11	571	480	16	4	2/2
12	1170	489	3	1	2/2
13	1170	489	3	1	2/2

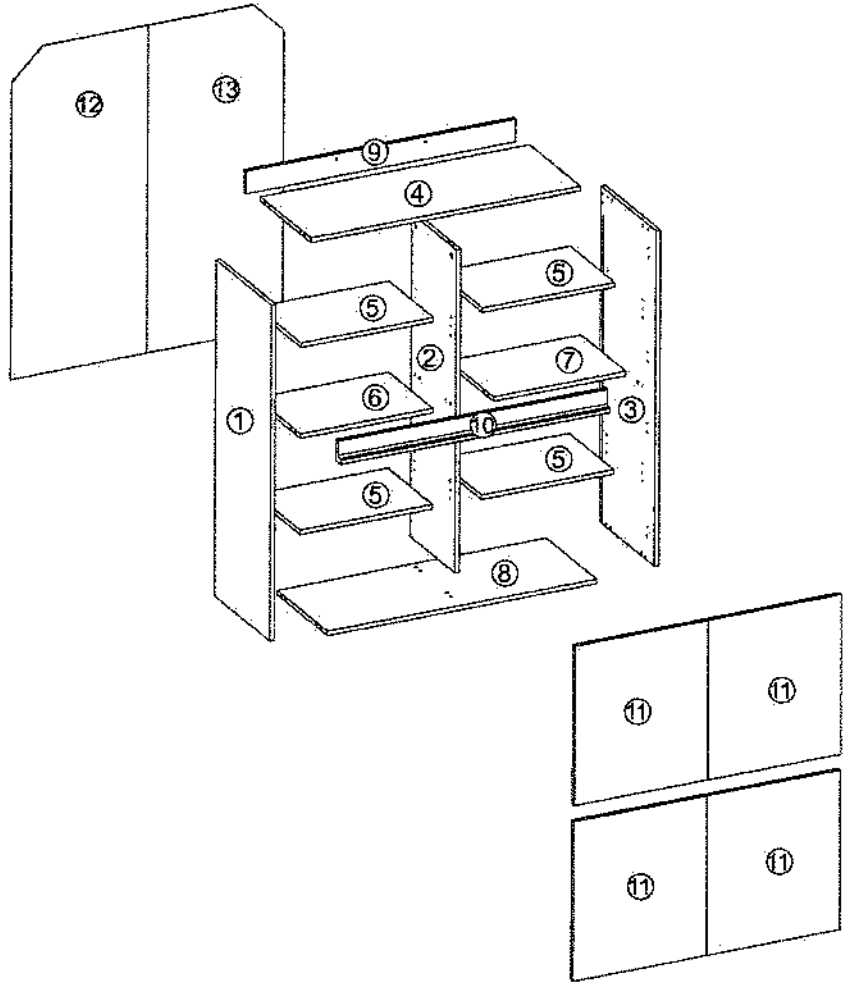

Modell: CITY / GIRON 71

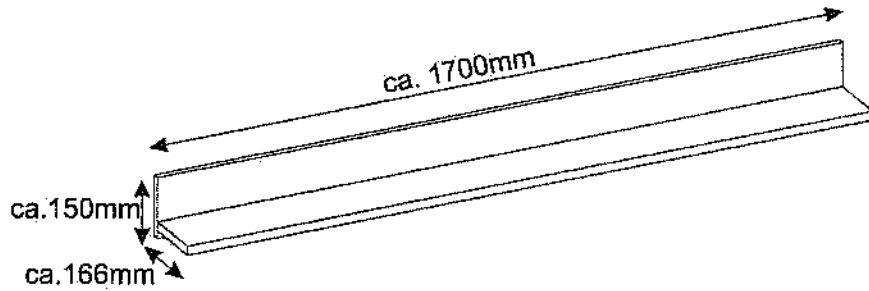

- Ⓛ Montageanleitung
- Ⓝ Handleiding voor de montage
- Ⓣ Montaj talimatı
- ⓕ Notice de montage
- Ⓒ Montážní návod
- ⓗ Szerelési útmutató
- ⓖ Assembly Instructions
- Ⓟ Instrukcja montażu
- Ⓡ Инструкция по монтажу
- Ⓜ Istruzioni di montaggio
- Ⓢ Návod na montáž
- Ⓡ Instrucțiuni de montaj
- ⓔ Instrucciones de montaje
- Ⓣ Montaj Talimatı

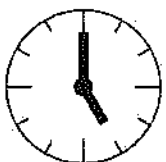
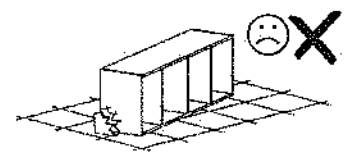
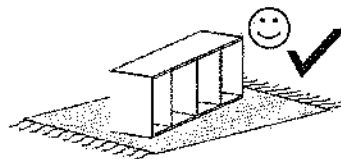
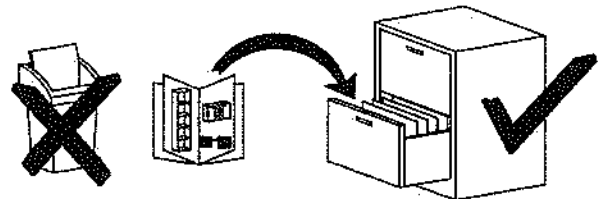
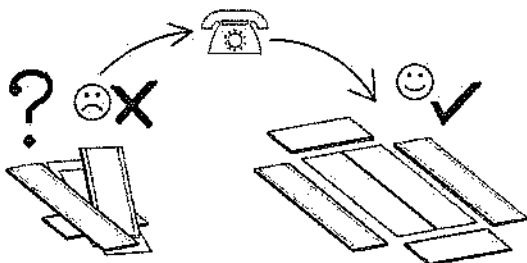
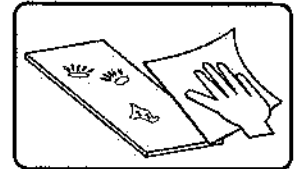
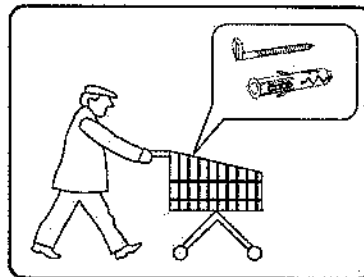
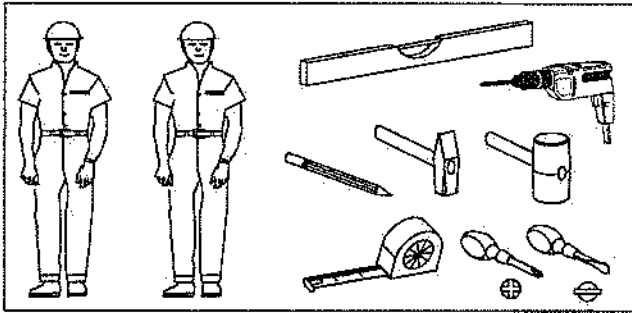



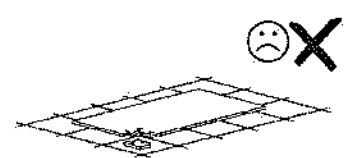
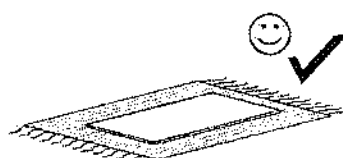

0,5h



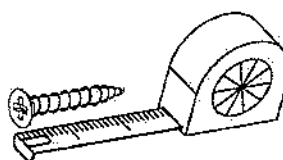
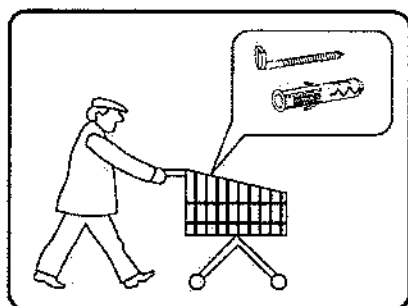
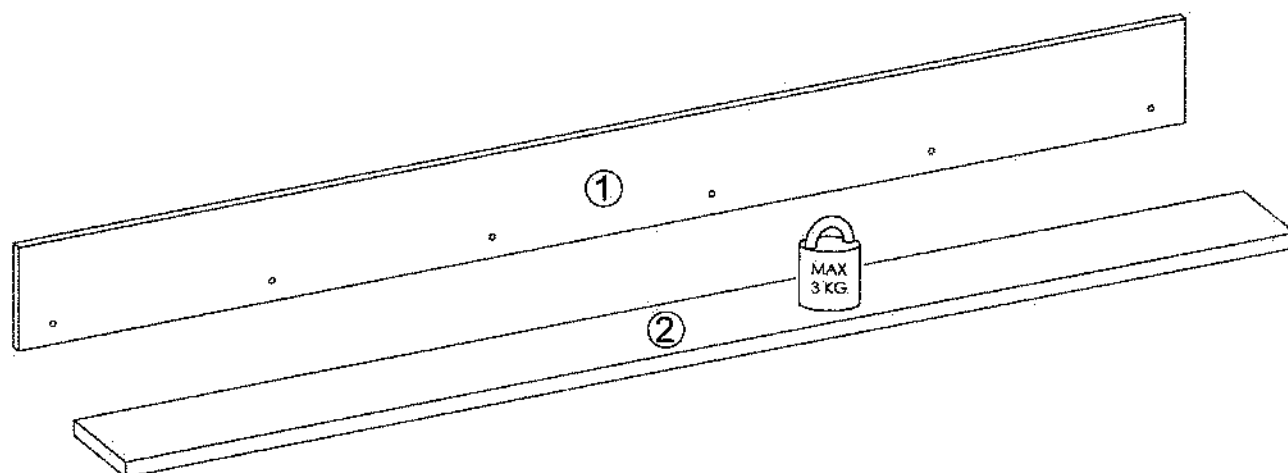

nr	L[mm]	B[mm]	T[mm]	Menge	Coll:
1	1700	150	16	1	1/1
2	1699	150	16	1	1/1

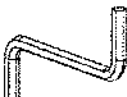

A1  ø7x50 x6	W2  x1	G52  5x11 x6	P10  x3
--	---	--	--



I

G52



5x11

P10



x6

x3

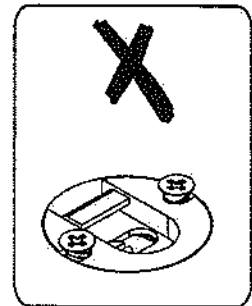
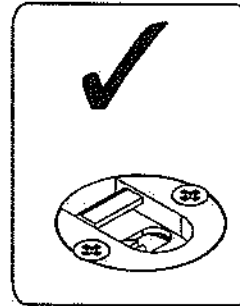
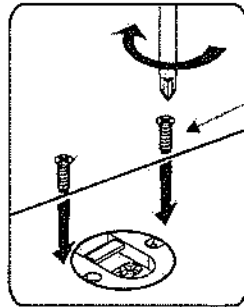
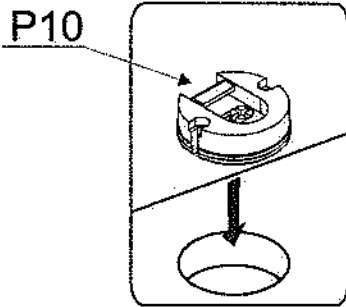
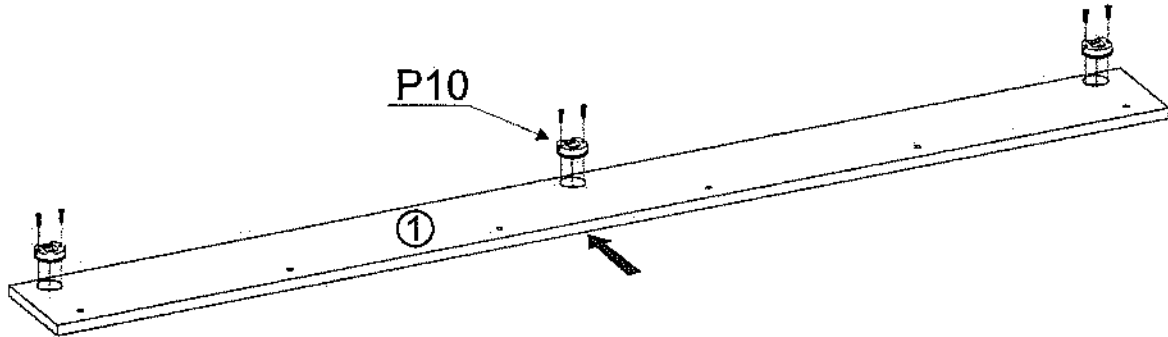

II

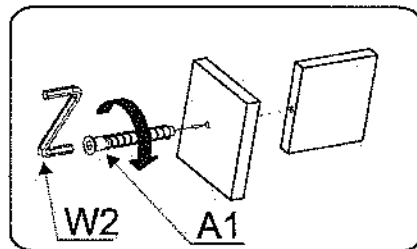

A1



ø7x50

x6

W2

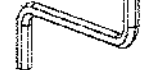

x1

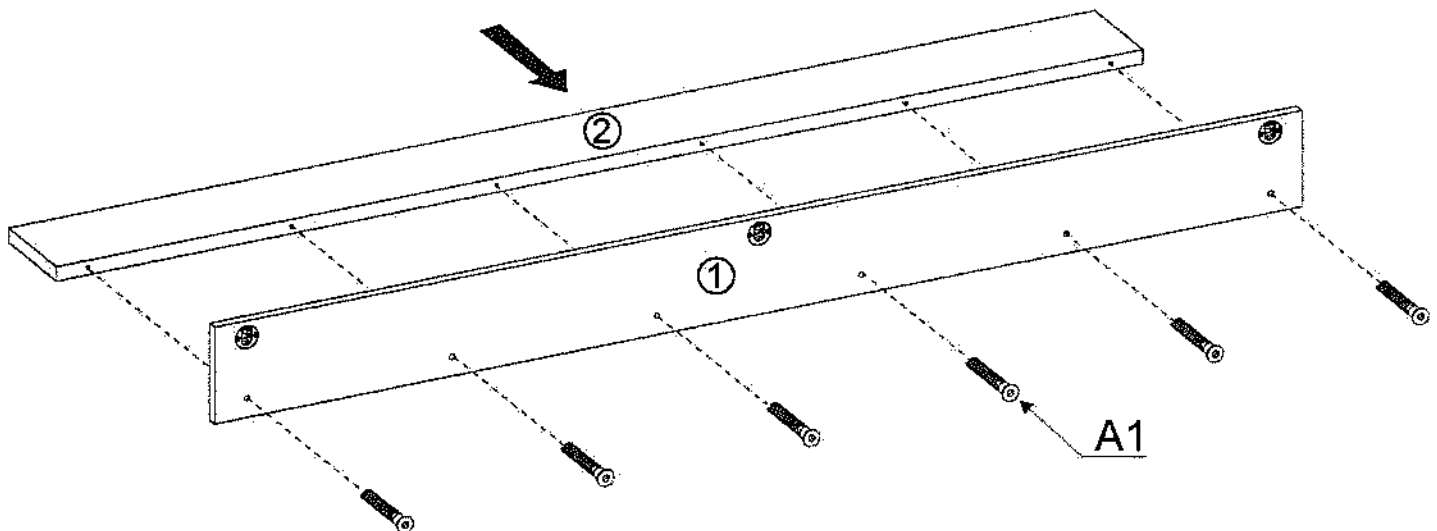



III

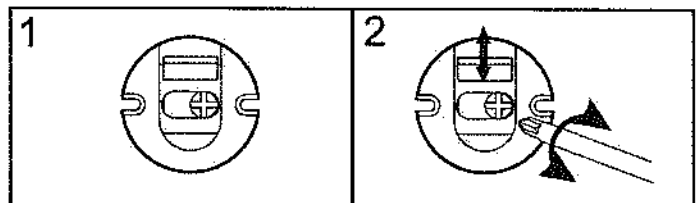
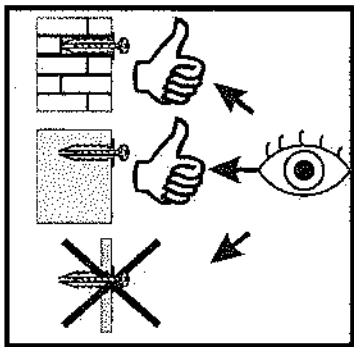
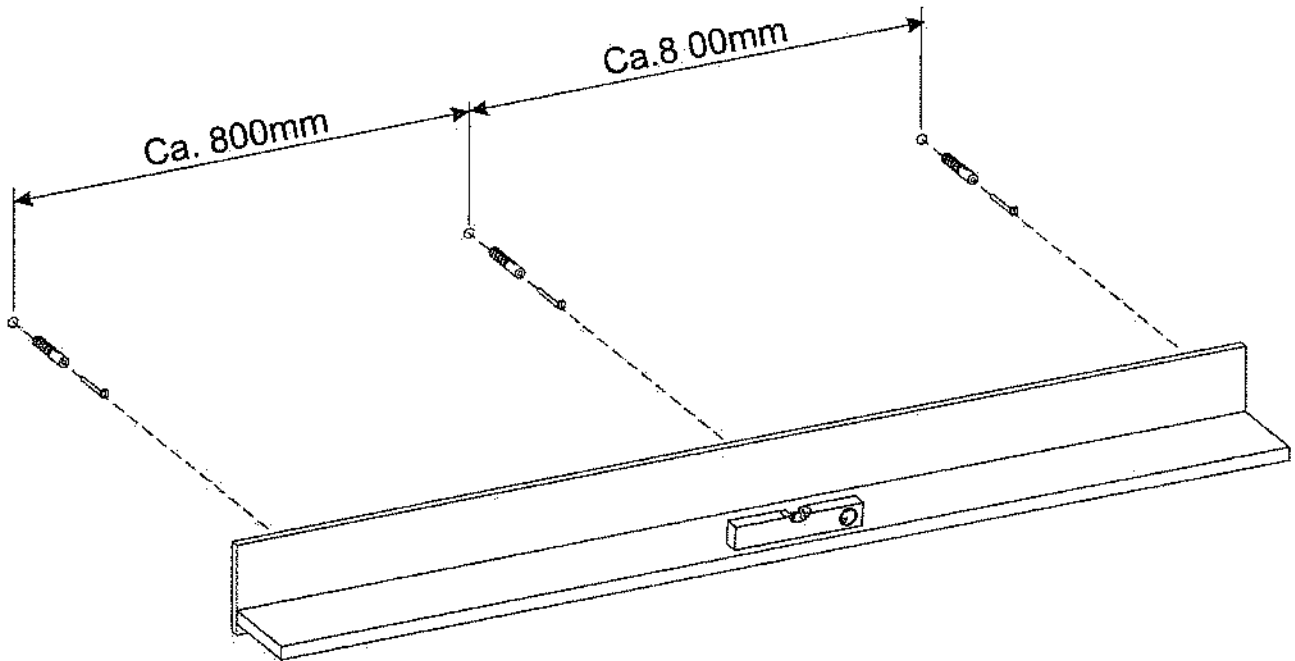
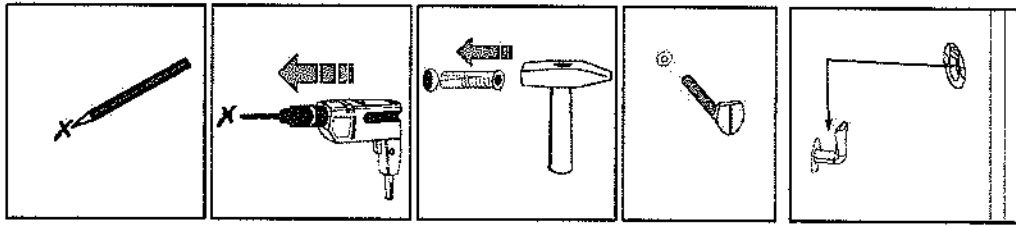
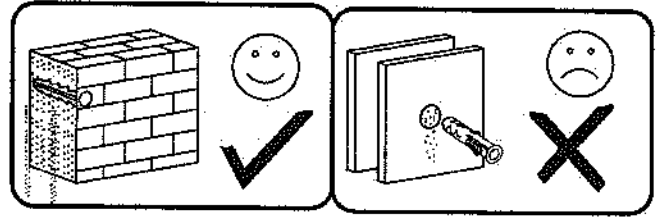
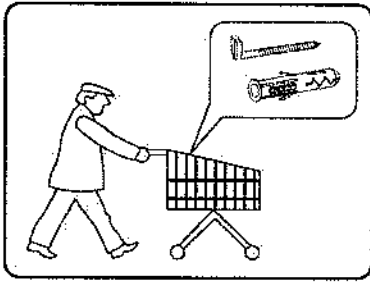

Name • Nom • Nome • Naam • Nazwa • Jméno
•Νόμος • Név • Denimire • İsim • Название

Nr • No • N° • Номер • Č • Sz

Typ • Type • Tip • Τύπος • Tipo • Tun

CITY / GIRON

— —

71

Unsere Direktservice für Beschlagteile

Sollte Ihnen ein Beschlagteil fehlen, können Sie diese Servicekarte direkt an die untenstehende Adresse mailen. Wir können allerdings nur Beschlagteile auf diesem Wege verschicken. Sollten Sie eine andere Beanstandung an Ihrem Möbelstück haben, so wenden Sie sich bitte direkt an Ihr Möbelhaus.

Our direct order service for fitting
If a fitting part is missing, you can e-mail this service card directly to the address below. However, we can only send fitting parts in this way. If you have any other cause for complaint concerning your item of furniture, please contact your furniture store directly.

Naše priame služby pro kování

Chybí-li vám nějaký díl z kování, můžete tuto servisní kartu odeslat e-mailem přímo na níže uvedenou adresu. Tuto cestou však můžeme zrealizovat jen díly kování. Pokud byste reklamovali jiný díl nábytku, obraťte se přímo na svého prodejce nábytku.

Bien servirer la notice de montage

Si vous manquez une ferrure, veuillez envoyer directement la présente carte service à l'adresse e-mail indiquée ci-dessous. Cependant, ceci nous permet uniquement d'envoyer des ferrures. Pour tout autre type de réclamation concernant votre meuble, veuillez contacter directement votre magasin d'ameublement.

Il nostro servizio diretto per l'ordine della ferramenta

Qualora Vi dovesse mancare un pezzo di fissaggio, allora Vi preghiamo di inviare questa carta di servizio immediatamente all'indirizzo sottostante. Possiamo inviare i pezzi di fissaggio solamente per mezzo di questo procedimento. Qualora dovreste avere qualche altra reclamazione in merito al mobile, allora Vi preghiamo di rivolgerVi direttamente al Vostro Negozio di mobili.

Írás a szabványos címre csak látható

Azt kérjük, ha van olyan rész hiányban, amit a szereléshez kellene, akkor ezt a szervizkártyát közvetlenül az alábbi címre küldje. Ezzel a módon csak a szerelési részeket tudjuk elküldeni. Ha van más panasz a bútortalálattal kapcsolatban, akkor forduljon közvetlenül a bútortalálójához.

Onze directservice voor losse onderdelen

Wanneer er een onderdeel ontbreekt, kunt u deze servicekaart direct aan onderstaand e-mailadres sturen. Wij kunnen langs deze weg echter alleen beslagdelen versturen. Mocht u een ander probleem aan uw meubel hebben, verzoeken wij u contact op te nemen met uw meubeldealer.

Nasz bezpośredni serwis części montażowych

Jeżeli brakuje części koniecznych do montażu, prosimy o przesłanie nam niniejszej karty serwisowej na niżej podany adres e-mailowy. W ten sposób możemy przesyłać jedynie tylko brakujące części. W przypadku innych reklamacji dotyczących mebla, prosimy zgłaszać się do salonu meblowego, w którym został dokonany zakup.

Servis za okove

U slučaju da nedostaje neki od dijelova molimo vas da na dolje navedenu mail adresu pošaljete ovaj servisni obrazac. Na ovaj način mogu se dostaviti samo okovi. U slučaju da imate dodatne prigovore vezane uz komad namještaja molimo vas da se obratite izravno trgovini namještaja gdje je isti kupljen.

Direktzorgátlalunk vasalatók esetén

Ha hiányzik egy vasaló, ezt a kártyát közvetlenül elküldheti az alábbi található címre. Azonban csak a vasalatókat tudunk így küldeni. Amennyiben másfajta reklamáció áll fenn bűtortalálját illetően, forduljon közvetlenül a bűtortalálójához.

Náš priamy servis pre štápi kovania

Ak by Vám chýbala nejaká časť štápi kovania, môžete poslať túto servisnú kartu priamo e-mailom na nižšie uvedenú adresu. Diely kovania vieme poslať iba týmto spôsobom. Ak by ste mali inú reklamáciu ohľadom Vášho nábytku, obráťte sa priamo na vášho predajcu nábytku.

Naše direktna služba za okove

Če vám manka nejaké okovy, lahko to servisno kartico pošljete po e-pošti direktno na spodnji naslov. Po tej poti vam lahko pošljemo samo okove. Če želite reklamirati kakšen drug del pohištva, se obrnite neposredno na vašo trgovino pohištva.

Servicio al usuario directo para ferreteria

In cazul în care vă lipseşte o piesă de feronerie puteţi să trimiteţi direct acest card de service prin e-mail la adresa de mai jos. Noi nu putem expedia piesa de feronerie decât pe această cale. Dacă aveţi o altă reclamaţie referitoare la piesa de mobilier, atunci vă rugăm să vă adresaţi direct la magazinul dvs. de mobilă.

Írás a szabványos címre csak látható

Azt kérjük, ha van olyan rész hiányban, amit a szereléshez kellene, akkor ezt a szervizkártyát közvetlenül az alábbi címre küldje. Ezzel a módon csak a szerelési részeket tudjuk elküldeni. Ha van más panasz a bútortalálattal kapcsolatban, akkor forduljon közvetlenül a bútortalálójához.

Vår direktservice för beslagdelar

Om du saknar en beslagdel kan du skicka detta servicekort direkt till e-postadressen som anges nedan. Tänk på att detta är den enda möjligheten att skicka beslagdelar till dig. Om du vill reklamera din möbel av en annan anledning måste du kontakta ditt möbelföretag direkt.

Nuestro servicio directo para accesorios

Si le falta algún accesorio, puede enviar esta tarjeta de servicio directamente a la siguiente dirección. No obstante, por este método solo podemos enviar accesorios. Si tiene alguna otra objeción sobre su mueble, consulte directamente con su mueblería.

Donatlar için doğrudan servisimiz

Bir donatınız eksikse bu servis kartını doğrudan aşağıda bulunan adrese doğrudan mail yazabilirsiniz. Sadece bu yolla donatılar gönderilebilir. Mobilyanızda başka bir kaygınız varsa lütfen doğrudan mobilya satıcınıza danışın.

nr	L[mm]	B[mm]	T[mm]	Menge	Coll.
1	1700	150	16	1	1/1
2	1699	150	16	1	1/1

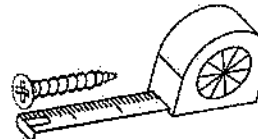
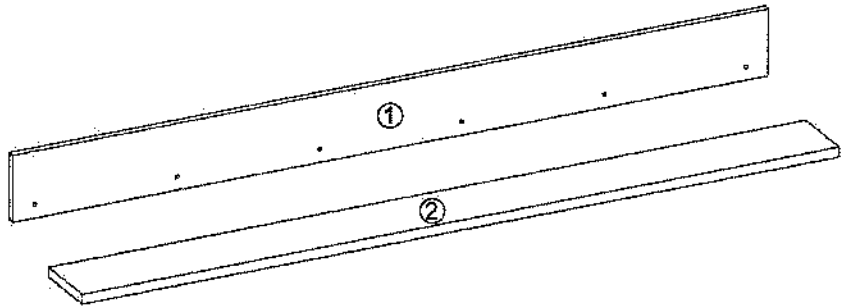

A1 ø7x50 X...	W2 X...
G52 5x11 X...	P10 X...

