

LKZ:80407

Modellname / Model name / Nom du modèle / Modellnamn / Nome modello / Název modelu / Modelnaam / Ime modela / Numéro Modelo / Modell neve / Название модели / Názov modelu / Ime modela / Denumire model / Наименование на модела / Nazwa modelu

**FOLLOW**

Modellnummer / Number / Numéro du modèle / Numero / Номер на модела / modello / Číslo modelu / Modell száma / Éíslo modelu / Številka modela / Număr model / Broj modela / Modelnummer / Numer modelu

**2228-405-E2**

Type / Tipo / Típus / Тип / Тип / Tip

**405**

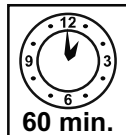
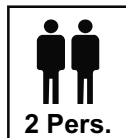
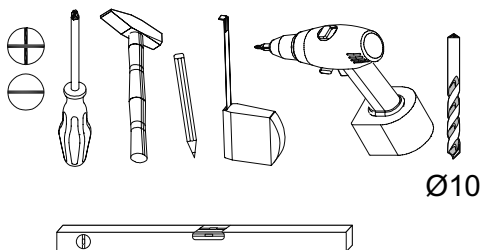
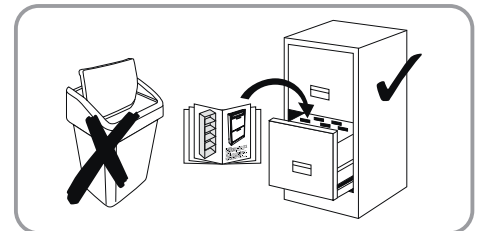
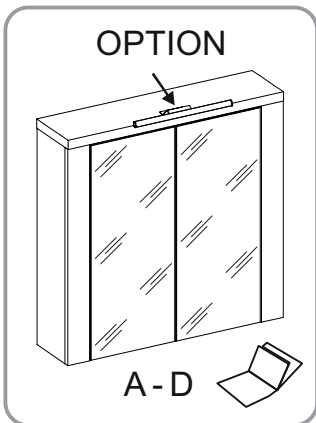
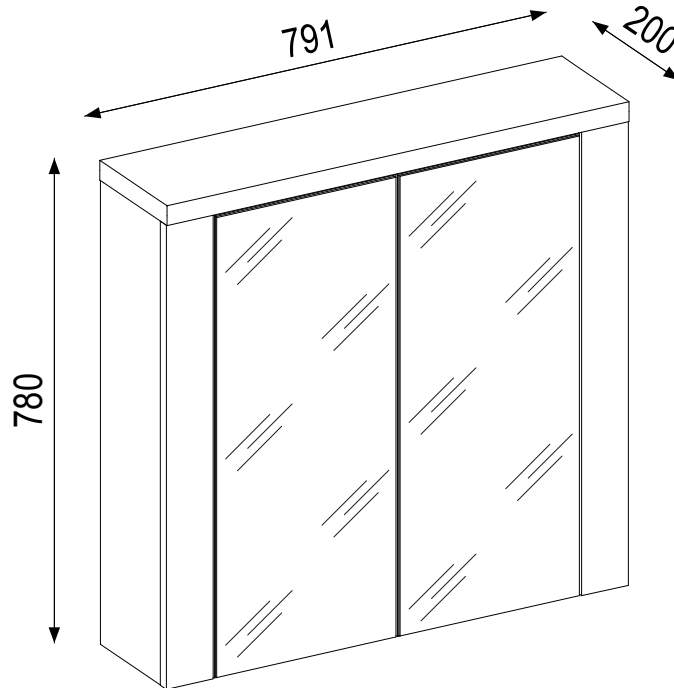
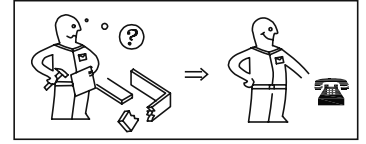
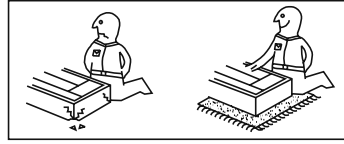
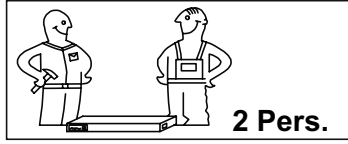
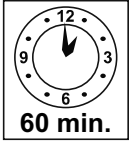

festziehen / tighten / Затянете / serrer / stringere / utåhnut / vasttrekken / zategnuti / strângere / zwiázac / zacisnaç / szorosan meghúzni / pevne dotiahnut / trdno pritegniti / затянуть / dra át



eindrücken / press in / enfoncer / wcisnaç / ribattere / zatlačit / Вкарайте / indrukken / benyomni / stlácit' / vtišniti / tryck in / introducere prin apăşare / вдавить



ausmessen / measure / mesurer / misurare / opmeten / izmeriti / miara / kimérni / izmeriti / mäsurare / измерить / změřit / Измерете / mät upp / zmierzyc



drücken / press / presser / stisknout / Натиснете / vtišniti / nasinac / drukken / pritisnuti / nacisnac / pritisniti / нажать / (meg)nyomni / apăşare / tryck fast / nacisnaç



einschlagen / hammer in / beverni / slain / frapper au marteau / infossare / Zabit' / zarazit / Набийте / zabit' / wbiç / introducere prin bătaie / забить / zatlout



Drehen - wenden / przekreçciç - odwróciç / Keren - omdraaien / Girare - Ruotare / Okrenuti - ubnuti / Retourner - renverser / Turn over - turn around / Otocte - obratit' / Zавъртете - обвъртете / Obrnite list / întoarceţi - rotiţi / Vrid runt - vänd / прокрутить - повернуть / otočit - obrátit / otočit - obrátit

LKZ:80407

Modellname / Model name / Nom du modèle / Modellnamn  
Nome modello / Název modelu / Modelnaam / Ime modela  
Número Modelo / Modell neve / Название модели /  
Názov modelu / Ime modelu / Denimare model /  
Наименование на модела / Nazwa modelu

**FOLLOW**

Modellnummer / Number / Numéro du modèle  
Numero / Номер на модела / modello  
Číslo modelu / Modell száma / Éíslo modelu  
Številka modela / Număr model / Broj modela  
Modelnummer / Numer modelu

2228-405-E2

Type / Tipo / Típus / Тип / Тип / Tip

**405**

D

Unser Direktservice für Beschlagteile

Sollte Ihnen ein Beschlagteil fehlen, können Sie diese Servicekarte direkt an die untenstehende Adresse mailen. Wir können allerdings nur Beschlagteile auf diesem Wege verschicken. Sollen Sie eine andere Beanstandung an Ihrem Möbelstück haben, so wenden Sie sich bitte direkt an Ihr Möbelhaus.

Our direct order service for fitting

If a fitting part is missing, you can e-mail this service card directly to the address below. However, we can only send fitting parts in this way. If you have any other cause for complaint concerning your item of furniture, please contact your furniture store directly.

Naše přímé služby pro kování

Chybí-li vám nějaký díl z kování, můžete tuto servisní kartu odeslat e-mailem přímo na níže uvedenou adresu. Touto cestou však můžeme zoslat jen díly kování. Pokud byste reklamovali jiný díl nábytku, obraťte se přímo na svého prodejce nábytku.

Bien etudier la notice de montage

S'il vous manque une ferrure, veuillez envoyer directement la présente carte service à l'adresse e-mail indiquée ci-dessous. Cependant, ceci nous permet uniquement d'envoyer des ferrures. Pour tout autre type de réclamation concernant votre meuble, veuillez contacter directement votre magasin d'ameublement.

Il nostro servizio diretto per l'ordine della ferramenta

Qualora Vi dovesse mancare un pezzo di fissaggio, allora Vi preghiamo di inviare questa carta di servizio immediatamente all'indirizzo sottostante. Possiamo inviare i pezzi di fissaggio solamente per mezzo di questo procedimento. Qualora dovete avere qualche altra reclamazione in merito al mobile, allora Vi preghiamo di rivolgerVi direttamente al Vostro Negozio di mobili.

Нашата директна услуга за обков

Ако липсват части от комплекта, попълнете настоящата сервисна карта и ни я изпратете на e-mail адреса, посочен по-долу. По този начин можем да доставяме само липсващи елементи от обкова. Ако установите други дефекти по мебелите, Ви съветваме да се обърнете към мебелната къща/магазин, от който сте закупили стоката.

Onze directservice voor losse onderdelen

Wanneer er een onderdeel ontbreekt, kunt u deze servicekaart direct aan onderstaand e-mailadres sturen. Wij kunnen langs deze weg echter alleen beslagdelen versturen. Mocht u een ander probleem aan uw meubel hebben, verzoeken wij u contact op te nemen met uw meubeldealer.

Nasz bezpośredni serwis czesci montazowych

Jeżeli brakuje części koniecznych do montażu, prosimy o przesłanie nam niniejszej karty serwisowej na niżej podany adres e-mailowy. W ten sposób możemy przesyłać Państwu tylko brakujące części. W przypadku innych reklamacji dotyczących mebla, prosimy zgłosić się do salonu meblowego, w którym został dokonany zakup.

Servis za okove

U slučaju da nedostaje neki od dijelova molimo vas da na dolje navedenu mail adresu pošaljete ovaj servisni obrazac. Na ovaj način mogu se dostaviti samo okovi. U slučaju da imate dodatne prigovore vezane uz komad namještaja molimo vas da se obratite izravno trgovini namještaja gdje je isti kupljen.

Direktszolgáltatunk vasalatok esetén

Ha hiányzik egy vasalat, ezt a kártyát közvetlenül elküldheti az alább található címre. Azonban csakis vasalatoskat tudunk így küldeni. Amennyiben másfajta reklamáció áll fenn bútorدارabját illetően, forduljon közvetlenül a bútoráruházhoz.

Náš priamy servis pre časti kovania

Ak by Vám chýbala nejaká časť kovania, môžete poslať túto servisnú kartu poslať e-mailom na nižšie uvedené adresu. Diely kovania vieme poslať iba týmto spôsobom. Ak by ste mali inú reklamáciu ohľadom Vašho nábytku, obraťte sa priamo na Vašu predajňu nábytku.

Naše direktne uslužne storitve za okovje

Ce vam manjka kakšno okovje, lahko to servisno kartico pošljete po e-pošti direktno na spodnji naslov. Po tej poti vam lahko pošljemo samo okovje. Če želite reklamirati kakšen drug del pohištva, se obrnite neposredno na vašo trgovino pohištva.

Service-ul nostru direct pentru feronerie

În cazul în care vă lipsesc o piesă de feronerie puteţi să trimiteti direct acest card de service prin e-mail la adresa de mai jos. Noi nu putem expedia piese de feronerie decât pe această cale. Dacă aveţi o altă reclamaţie referitoare la piesa de mobilier, atunci vă rugăm să vă adresaţi direct la magazinul dvs. de mobilă.

Наш прямой сервис для поставок фурнитуры

Если окажется, что Вам не хватает того или иного элемента фурнитуры, Вы можете отправить сервисную карту по факсу непосредственно на нижеприведенный адрес электронной почты. Однако, таким образом мы можем пересылать лишь фурнитуру. Если же у Вас возникнут иные претензии относительно приобретенной мебели, пожалуйста, обращайтесь непосредственно в организацию, осуществившую продажу.

Vår direktservice för beslagsdelar

Om du saknar en beslagsdel kan du skicka detta servicekort direkt till e-postadressen som anges nedan. Tänk på att detta är den enda möjligheten att skicka beslagsdelar till dig. Om du vill reklamera din möbel av en annan anledning måste du kontakta ditt möbelhus direkt.

Nuestro servicio directo para accesorios

Si le falta algún accesorio, puede enviar esta tarjeta de servicio directamente a la siguiente dirección. No obstante, por este método solo podemos enviar accesorios. Si tiene alguna otra objeción sobre su mueble, consulte directamente con su mueblería.

Donatilar için doğrudan servisimiz

Bir donatınız eksikse bu servis kartını doğrudan aşağıda bulunan adrese doğrudan mail yazabilirsiniz. Sadece bu yolla donatıları gönderebiliriz. Mobilyanızda başka şikayetleriniz varsa lütfen doğrudan mobilya satıcınıza danışın.

GB

CZ

F

I

BG

NL

PL

HR

HU

SK

SLO

RO

RUS

S

ES

TR

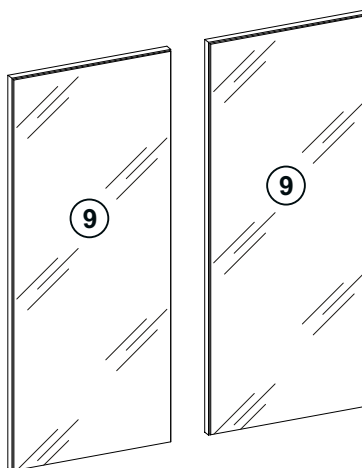
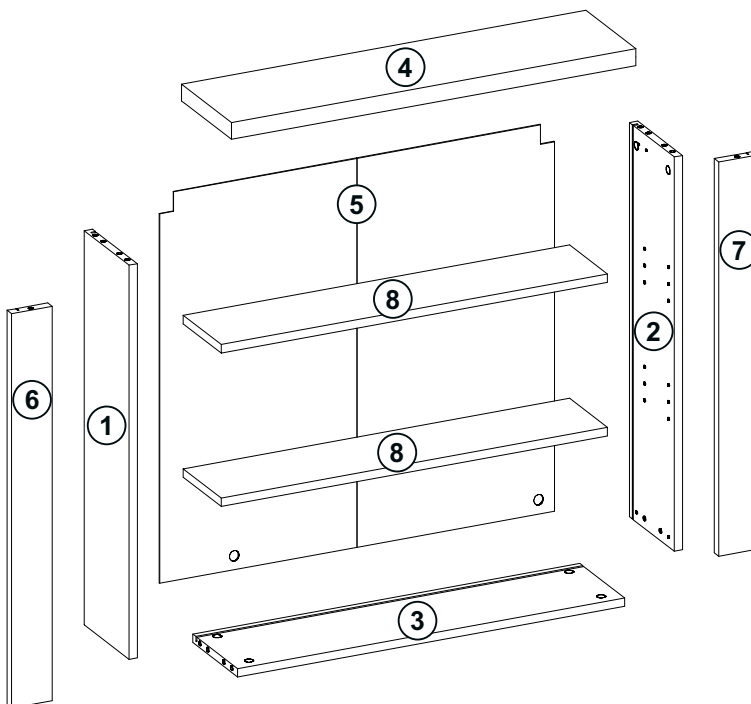
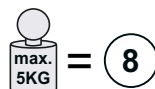
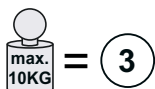

A	B (mm)		C	D
1	748	180	16	x1 1/1
2	748	180	16	x1 1/1
3	757	180	16	x1 1/1
4	791	200	32	x1 1/1
5	738	772	2,5	x1 1/1
6	748	80	18	x1 1/1
7	748	80	18	x1 1/1
8	756	152	16	x2 1/1
9	311	745	19	x2 1/1
B1				1/1

Grund der Beanstandung / Cause for complaint:

Möbelhaus / Furniture store:

Kunde/ Customer:

Telefon / Telephone:

PLZ / Postcode:

Ort / City:

Str. +Nr / Street address:

@E-Mail:

LKZ:80407

Modellname / Model name / Nom du modèle / Modellnamn  
Nome modello / Název modelu / Modelnaam / Ime modela  
Numéro Modello / Modell neve / Название модели /  
Názov modelu / Ime modela / Denumire model /  
Наименование на модела / Nazwa modelu

**FOLLOW**











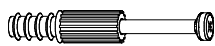

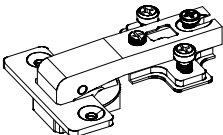
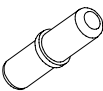
Modellnummer / Number / Numéro du modèle  
Numero / Номер на модела / modello  
Číslo modelu / Modell száma / Éíslo modelu  
Številka modela / Număr model / Broj modela  
Modelnummer / Numer modelu

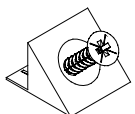
2228-405-E2

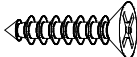
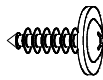
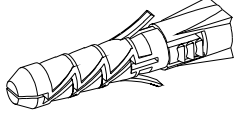
Type / Tipo / Típus / Тип / Тип / Tip

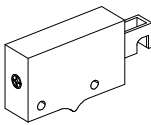
**405**

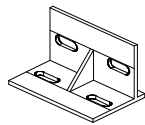
**B1 Colli 1/1**

<p><b>C2</b></p>  <p>44mm x8</p>	<p><b>A1</b></p>  <p>15x12 x8</p>	<p><b>B2</b></p>  <p>8x30 x10</p>
<p><b>K9</b></p>  <p>Ø35 x4</p>	<p><b>N1</b></p>  <p>Ø6 x8</p>	<p><b>O1</b></p>  <p>Ø18 x8</p>
<p><b>M1</b></p>  <p>10x10x15 x14</p>	<p><b>R5</b></p>  <p>Ø6 x2</p>	<p><b>D11</b></p>  <p>3,5x16 x8</p>
<p><b>DA21</b></p>  <p>4,2x16 x16</p>	<p><b>Y39</b></p>  <p>10x50 x2</p>	<p><b>Y41</b></p>  <p>55mm x2</p>
<p><b>Y1</b></p>  <p>x2</p>	<p><b>D30</b></p>  <p>4x30 x4</p>	<p><b>T1</b></p>  <p>30x35x55 x4</p>
<p><b>O6</b></p>  <p>Ø20 x2</p>		

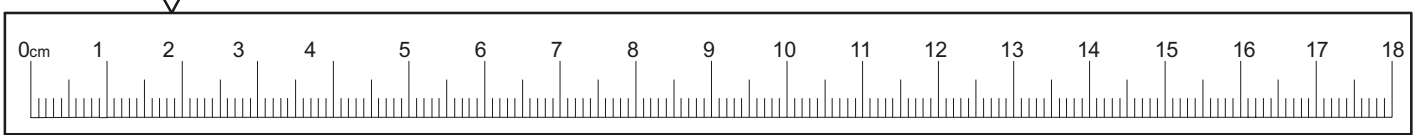
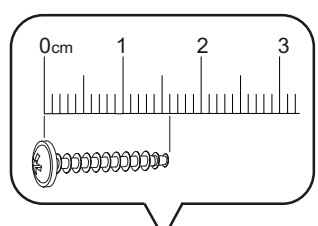











Değerli müşterimiz, evde kullanım için tasarlanan iç mekan programımızdan bir mobilya satın aldıysanız için teşekkür ederiz. Lütfen teslimat kapsamının eksiksiz olup olmadığını kontrol edin ve montajdan önce aşağıdaki önemli bilgileri dikkatlice okuyun ve daha sonra üçüncü şahıslar tarafından da kullanılmak üzere saklayın.

Mobilyalarımız amaçlandığı şekilde kullanılmalıdır. Amacı dışında kullanım, maddi hasarlar veya bazı durumlarda kişisel yaralanmalara neden olabilir. Mobilyalar çocuk oyuncakları değildir. Üretici veya satıcı, amaç dışında veya yanlış kullanımdan kaynaklanan hasarlar için hiçbir sorumluluk kabul etmez.

**D İ K K A T:** Çocuklar veya zihinsel engelli kişiler, yaralanma ve/veya bozulma riski bulunduğundan, mobilya parçalarından, sivri uçlu nesnelere, küçük parçalardan ve ambalaj malzemelerinden daima uzak tutulmalıdır.

**M O N T A J:** Montaj sırasında lütfen işletim, kullanım, kurulum veya montaj talimatlarınıza uygun ve uyan ve güvenlik talimatlarına özellikle dikkat edin. Talimatlara uyulmaması, kişisel yaralanmaya veya mobilya hasarına/güvenlik riskine neden olabilir. Montaj / kurulum konusunda zorluk yaşıyorsanız, lütfen servis ekibimize iletişime geçin. Ekibimiz tavsiyeleriyle ve destekleriyle size yardımcı olacaktır. Montaj sadece uzman kişiler tarafından yapılmalıdır. Ürün/ürün parçalarında değişiklikler,

üreticiden/satıcıdan gelmeyen parçalarla/sarf malzemeleriyle değiştirilmesi veya kullanılması durumunda meydana gelebilecek hasarlar için sorumluluk kabul edilmez.

Ürünleri dübel ve vida gibi duvara sabitleme araçları eklenmişse, bunlar sadece sağlam ve tek tip malzemelerden yapılmış duvarlarda kullanılmak üzere tasarlanmıştır. Bir bağlantı sadece bağlantı elemanı ve duvar arasındaki bağlantı kadar iyidir. Lütfen mobilyayı sabitlemeden önce duvarın zemine ayakta hem de asılı mobilya için uygunluğunu kontrol edin ve sadece uygun bağlantı elemanları kullanın. Olası bir delme işleminden önce delme alanında testisat olmadıysanız emniyetli olarak, montaj yapan kişi duvara sabitlemekten sorumludur. Bu aynı zamanda elektrikli parçaların ve diğer yapısal aksesuarların montajı için de geçerlidir. Elektrikli parçaların ve diğer inşaatla ilgili aksesuarların montaj/kurulumu sadece yetkili uzman personel tarafından yapılabilir. Tüm elektrik ve yapısal kurulumlar, eyaletinizdeki geçerli standartlara ve güvenlik yönetmeliklerine uygun olarak yapılmalıdır. Işık kaynakları için lütfen sadece izin verilen aydınlatma güçlerini kullanın. Maksimum Watt değerine uyulmaması durumunda aşırı ısınma nedeniyle yangın riski söz konusudur. Yangın tehlikesi nedeniyle aydınlatmaların üstünü kapatmak yasaktır.

Mobilyaların düzgün fonksiyonu sadece düz ve yatay konumda garanti edilir. Kapılar önceden ayarlanmıştır, ancak yerel koşullar nedeniyle yeniden hizalanması/ayarlanması gerekebilir. Lütfen maksimum yük ile ilgili ağırlık bilgilerine uyun.

Mobilyaların üzerine çıkılması yasaktır. Yanlış kullanım mobilyaların devrilmesine neden olabilir. Bunu önlemek için mobilyalar her zaman devrilmeye karşı emniyete alınmalıdır. Aşırı yük/aşırı zorlama durumunda (özellikle oyun oynayan çocuklar, insanlar, malzeme veya diğer uygunsuz etkilere nedeniyle) kırılma ve yaralanma riski söz konusudur. Kalıcı sağlamlığı güvenceye almak için tüm vidalar ve yük taşıyan bağlantı noktaları 5-6 hafta sonra tekrar sıkılmalıdır.

**B A K I M:**  
-Mobilya bakımıyla ilgili notlar-  
Ürünümüzün keyfini olabildiğince uzun süre çıkarabilmeniz için lütfen uygun mobilya bakımıyla ilgili talimatlarımıza dikkate alın.  
Temizlik sırasında temiz, kuru ve yumuşak pamuklu bir bez kullanın. Mobilyanızın kapsamlı bir temizliğe ihtiyacı varsa, bezi biraz su veya mobilya temizleyicisiyle nemlendirebilir ve ardından temizlenen eşyaları kurutabilirsiniz. Metal ve cam parçaları, üzerlerindeki bakım talimatlarına göre piyasada bulunan metal ve cam temizleyicilerle en iyi şekilde temizleyebilirsiniz. Temizlik maddeleri, mobilya temizliği için uygun olduklarını açık bir göstergesini taşımaktadır.  
Hiçbir koşulda buharlı temizleyiciler, kostik, aşındırıcı veya etkilere aşına olmadığınız diğer maddeleri kullanmamalısınız.

**D İ K K A T:** Çok parlak yüzeyler teslimat sırasında koruyucu bir folyoyla korunur. Bunu tamamen monte edilene ve tozu temizlenene kadar mobilya üzerinde bırakın. Koruyucu folyonun çıkarıldığı çok parlak elementler ancak 72 saat sonra temizlenebilir ve kullanılabilir (ortam havasında son katlaşma süresi). Yüzeylere keskin nesnelere zarar vermeyin ve asla güçlü güneş ışığına maruz bırakmayın.

**T A S F İ Y E**  
-Tasfiyeyle ilgili notlar-  
Çevre için lütfen türüne göre ayrılmış ambalaj atıklarını doğaya değil, bunlar için sağlanan atık/geri dönüşüm kutularında tasfiye edin.  
Hasarlı veya kullanılmayan mobilyalar, her bir parçanın geri dönüştürülmesi için özel geri kazanım tesislerine gönderilebilir.

Artık kullanılmayan ancak hala işlevsel olan mobilyaların hemen tasfiye edilmesi gerekmez. Bunları örneğin hayır kurumlarına bağışlayın.

Yeni mobilyalarınızı güle güle kullanın.

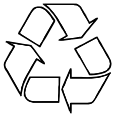
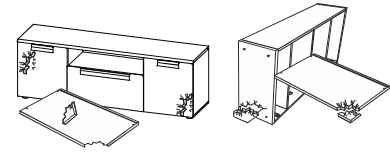
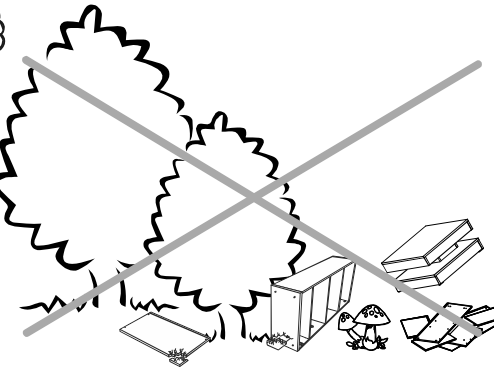
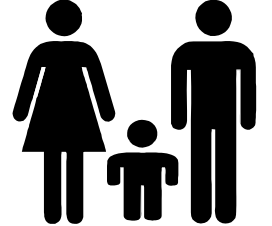
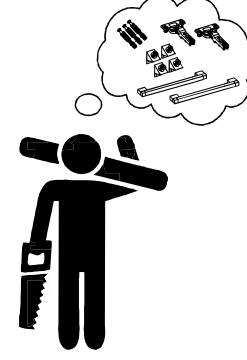
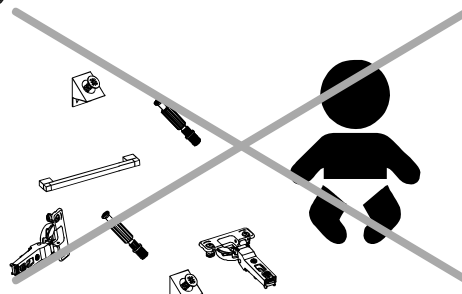
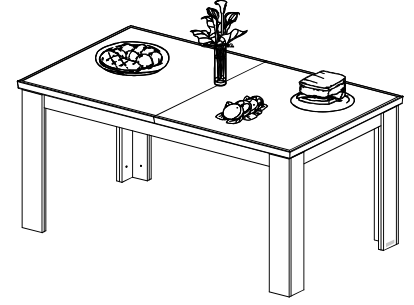
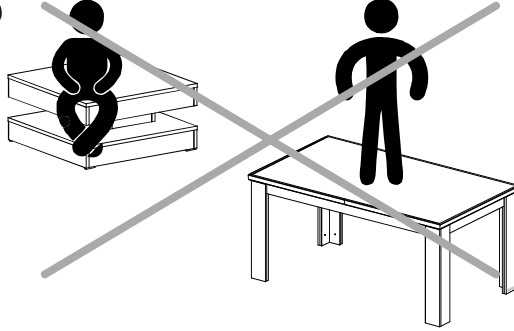
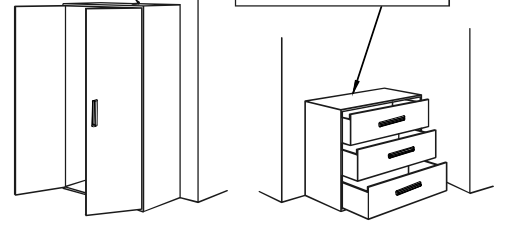
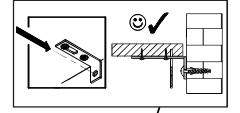
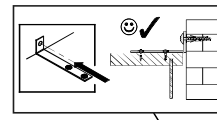
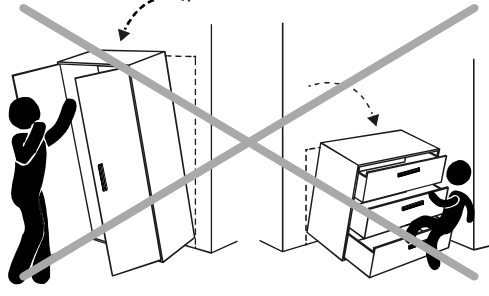



# 1

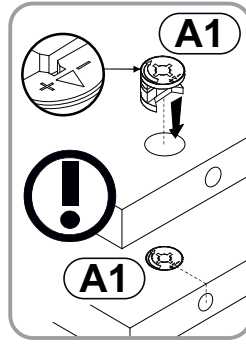
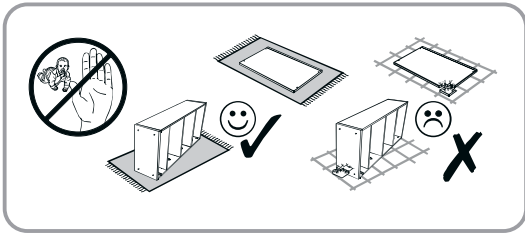

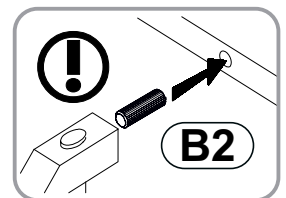
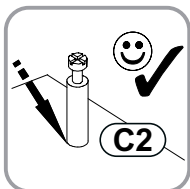
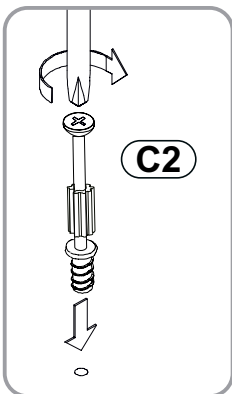
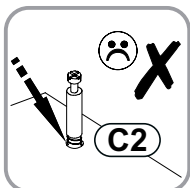
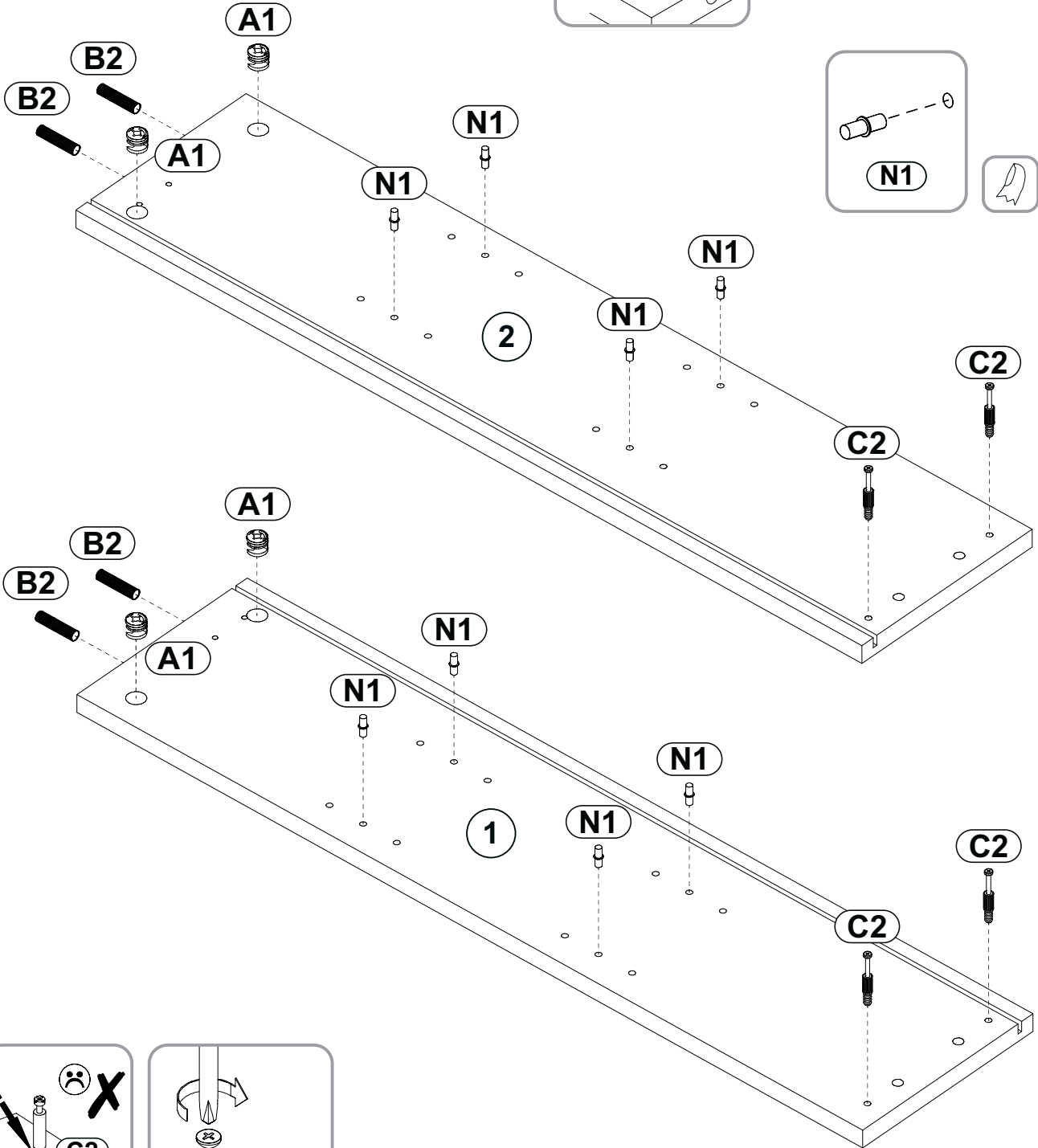
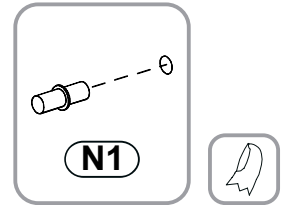

- B2** 8x30 x4
- N1** Ø6 x8
- C2** 44mm x4
- A1** 15x12 x4

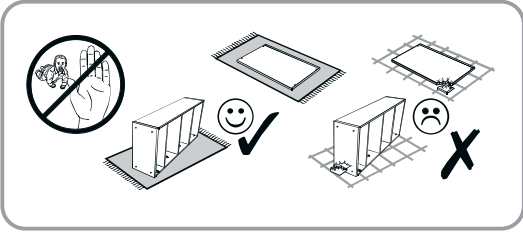

2



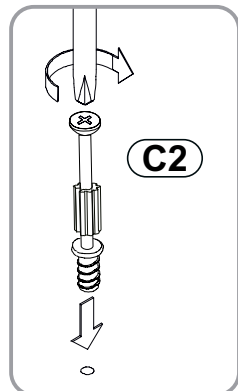
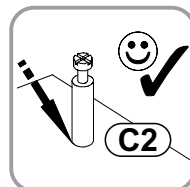
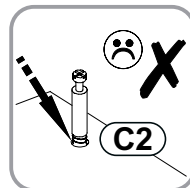
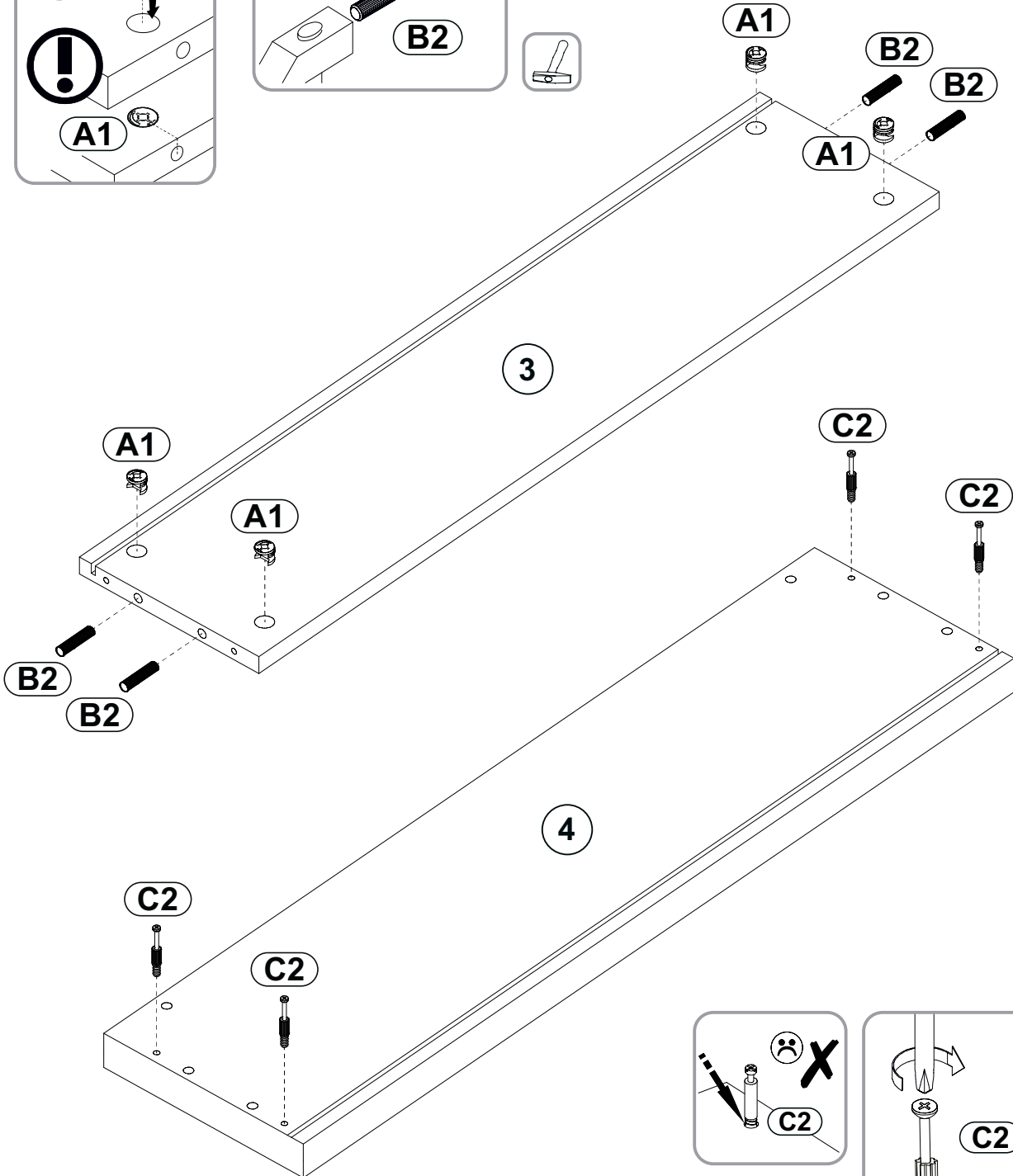
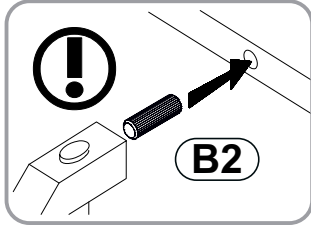
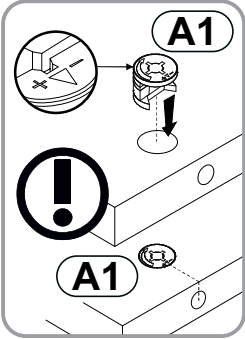

- A1** 15x12  x4
- B2** 8x30  x4
- C2** 44mm  x4

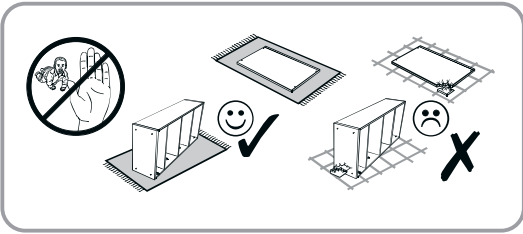

3

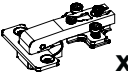

**K9**  x4  
Ø35

**DA21**  x8  
4,2x16

**T1**  x4  
30x35x55

**B2**  x2  
8x30

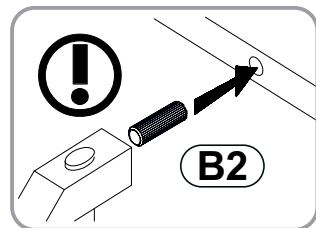
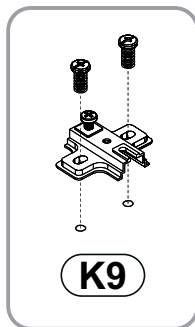
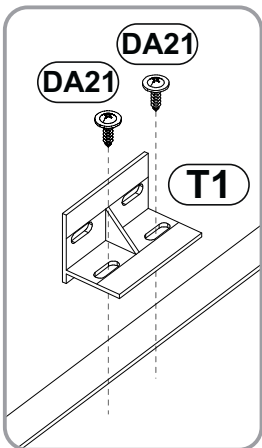
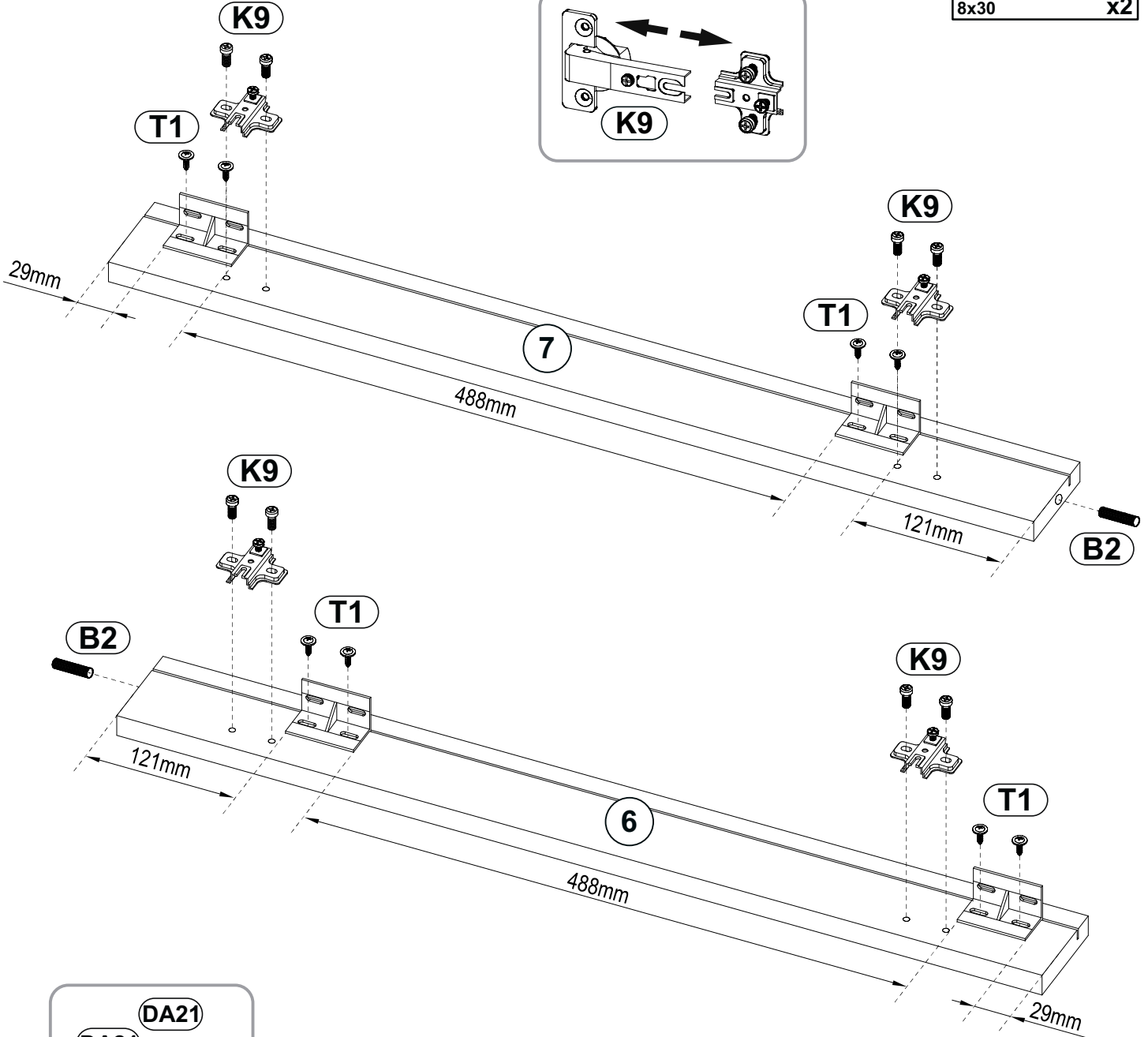
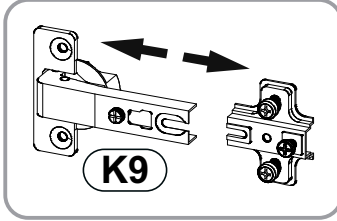

4

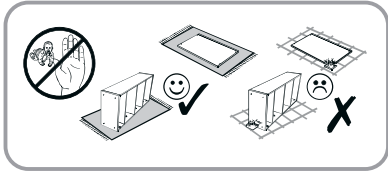

DA21  
4,2x16 x8

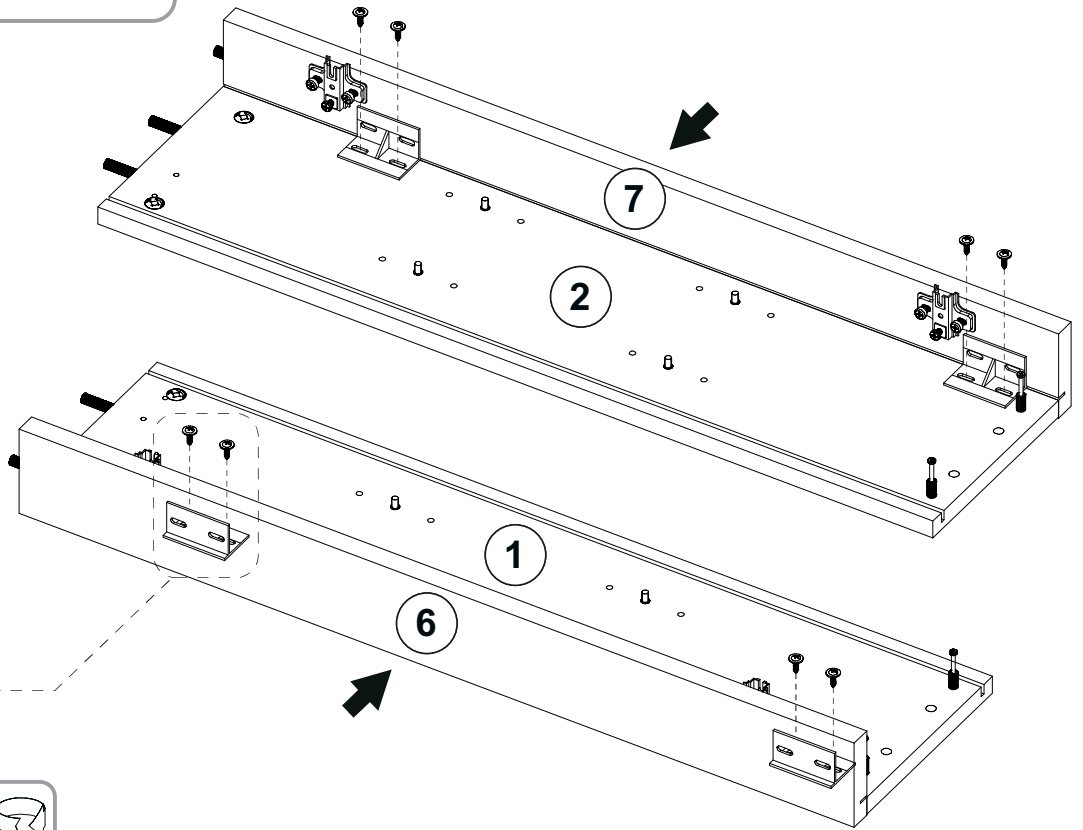
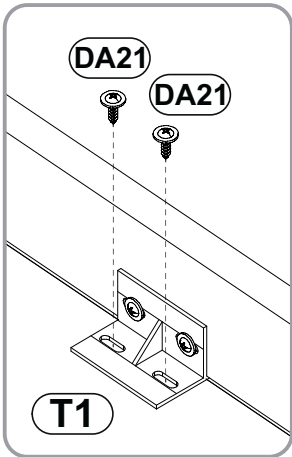
5

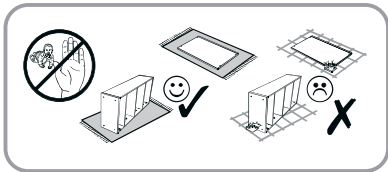

O1  
Ø18 x4

6

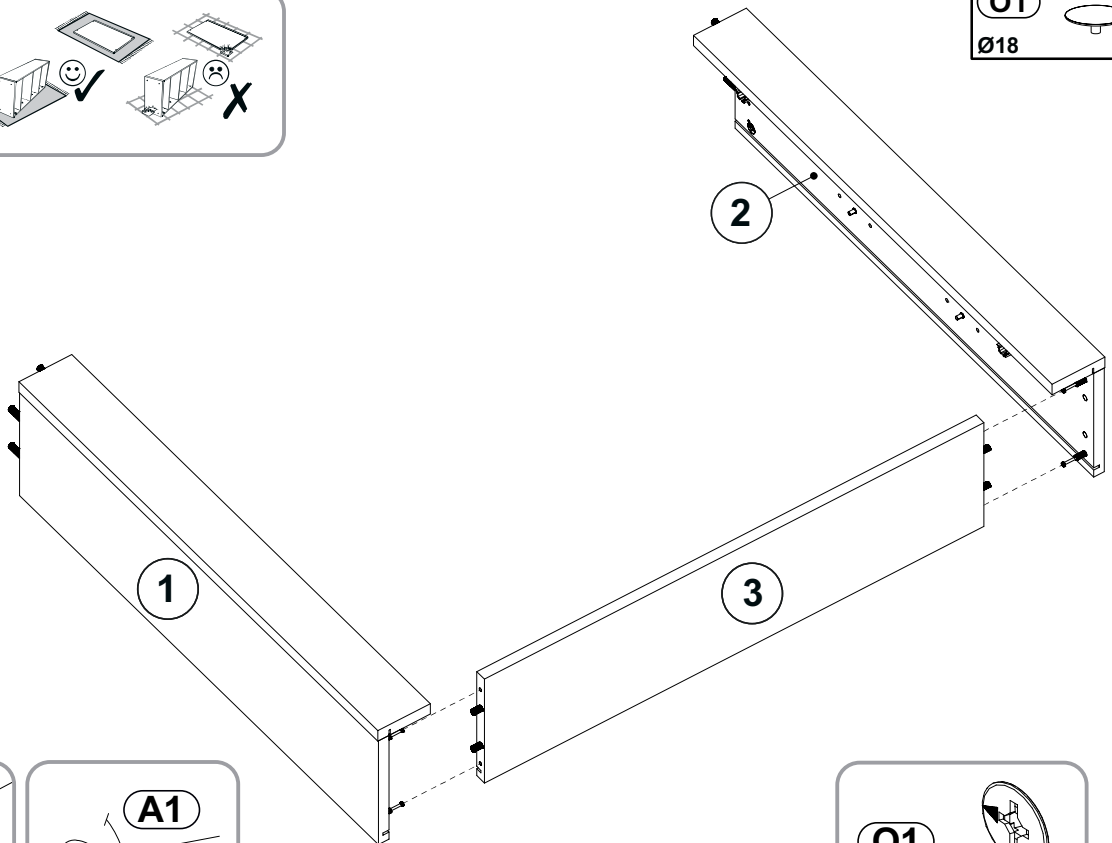
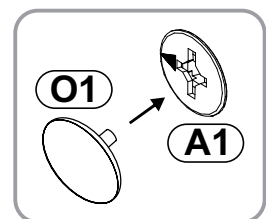
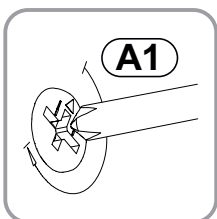
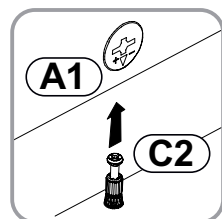

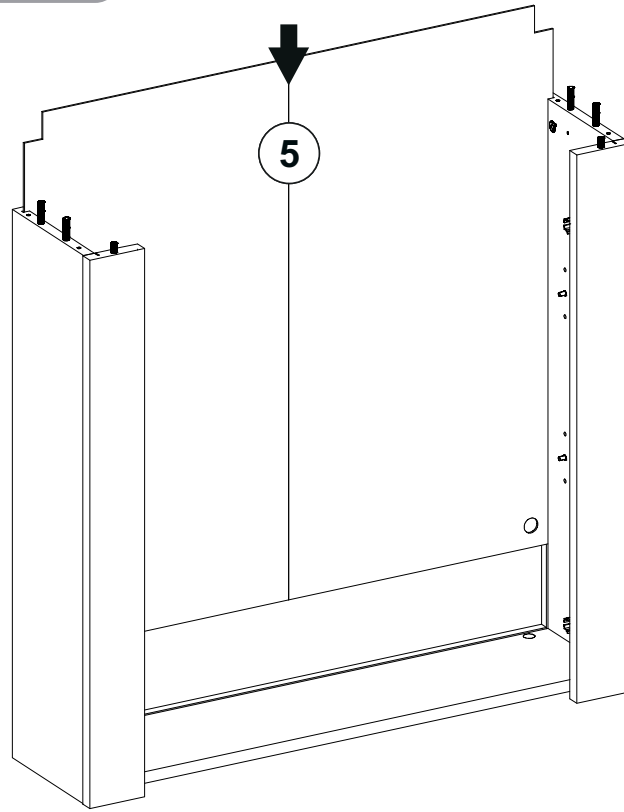
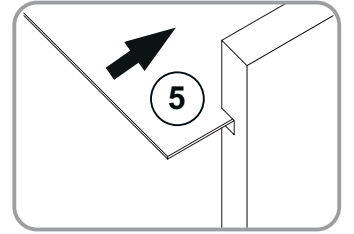
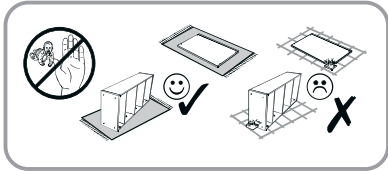
7

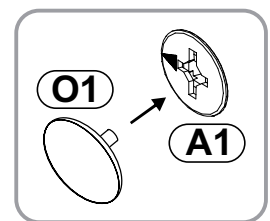
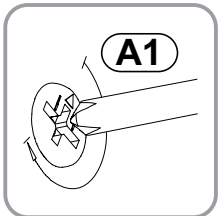
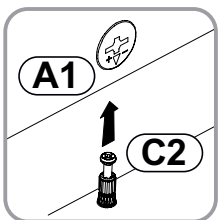
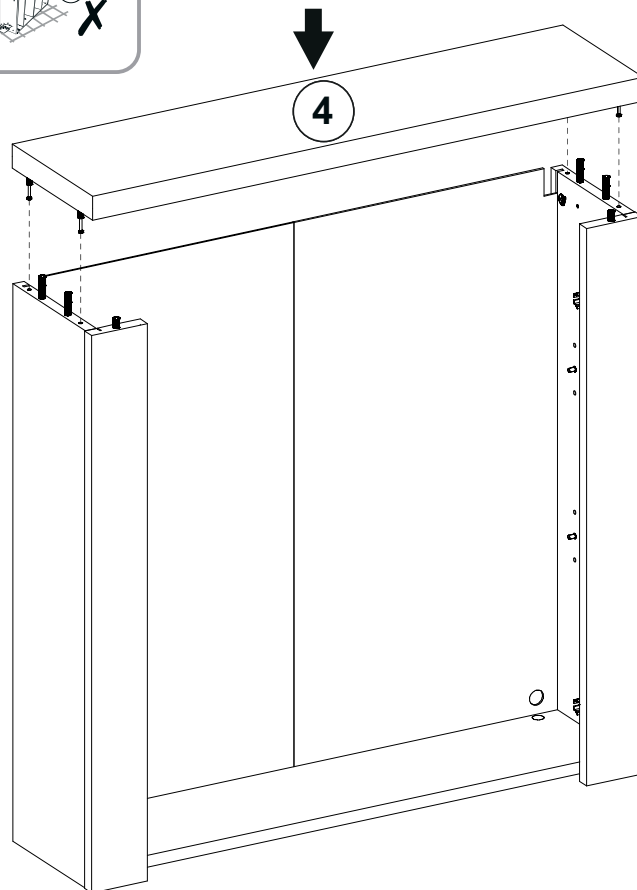
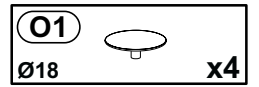
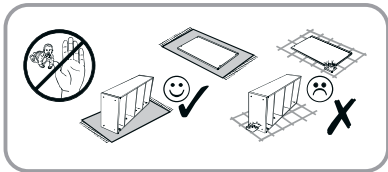

8

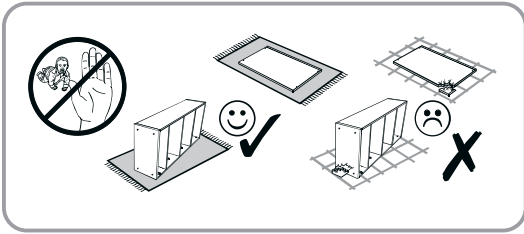

M1  
10x10x15 x14

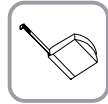
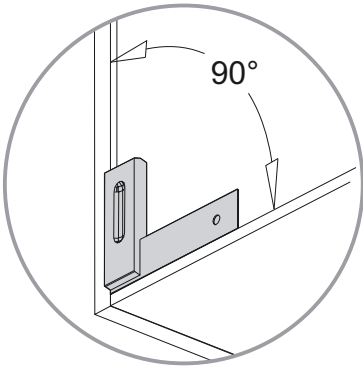

A=B

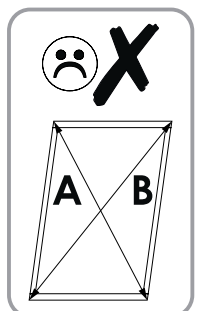
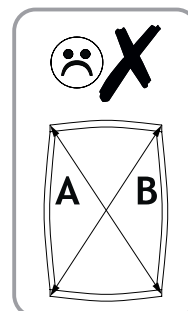
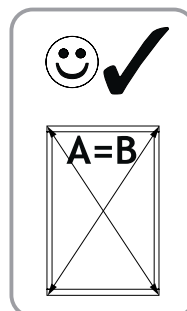
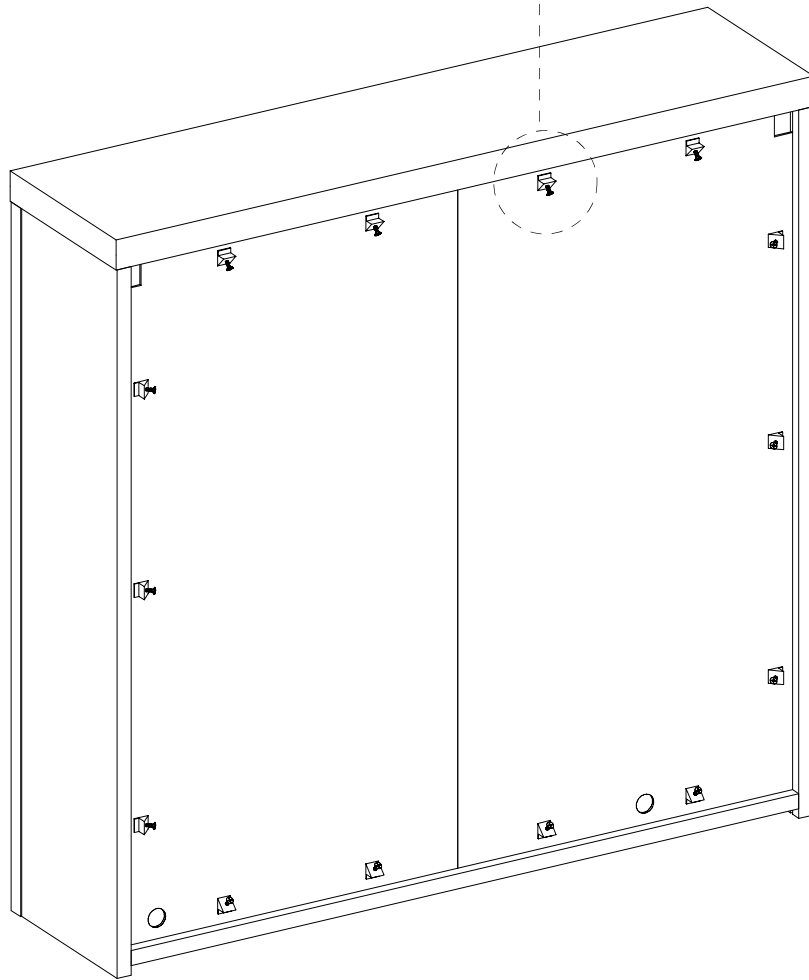
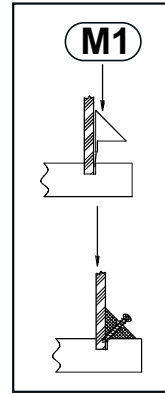
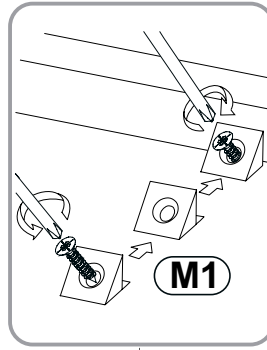

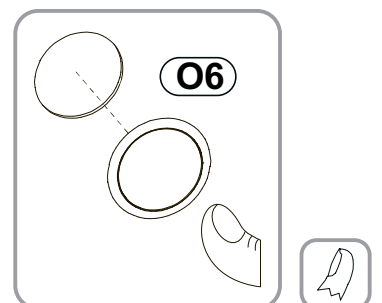
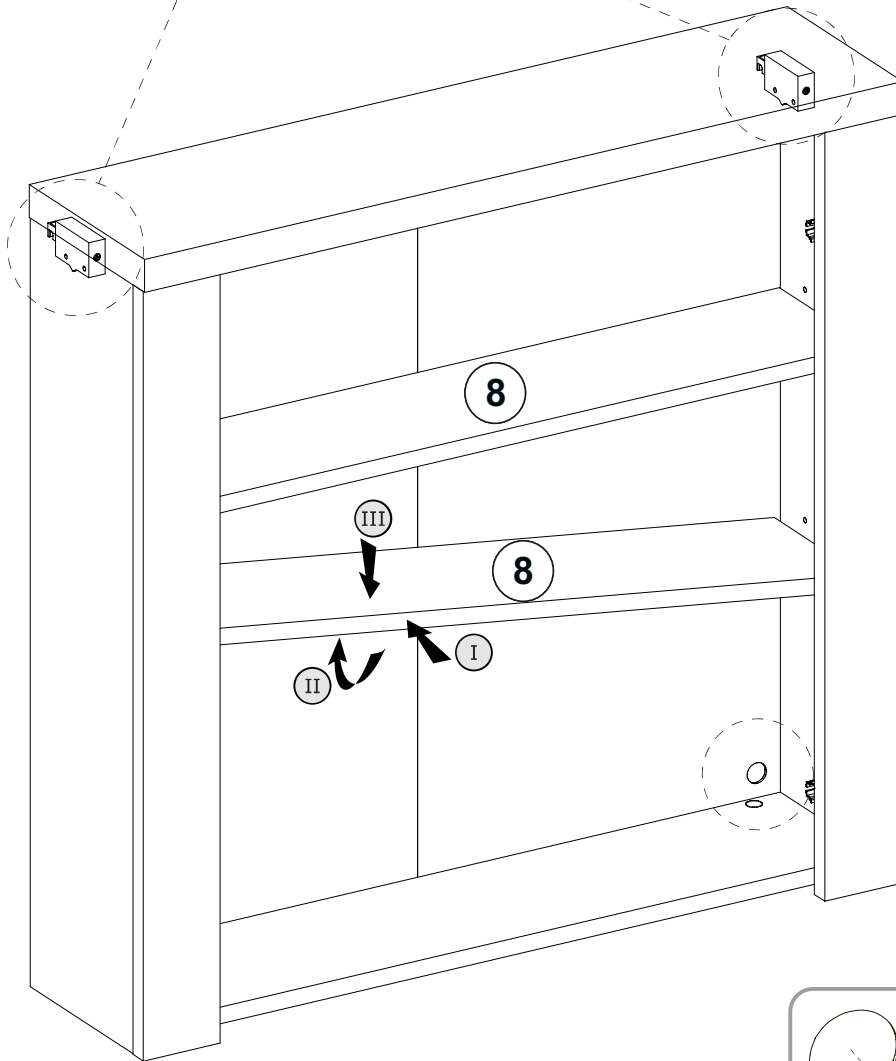
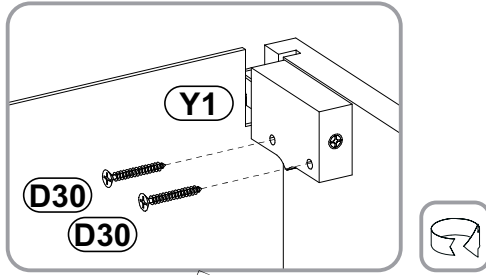
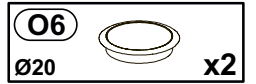
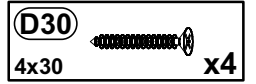
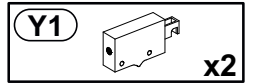
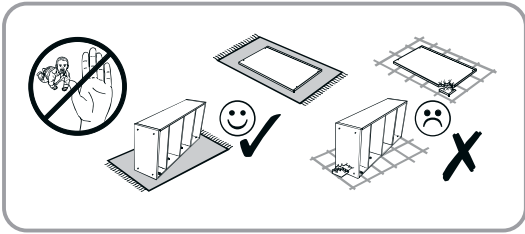

9



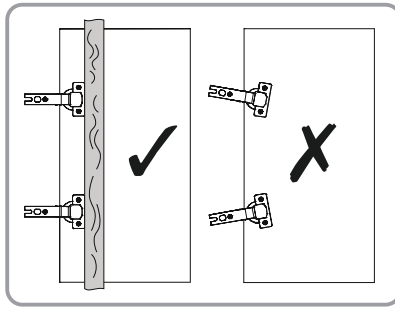
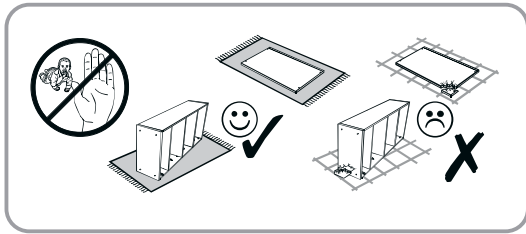

# 10

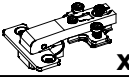

<b>K9</b> Ø35		<b>x4</b>
<b>D11</b> 3,5x16		<b>x8</b>
<b>R5</b> Ø6		<b>x2</b>

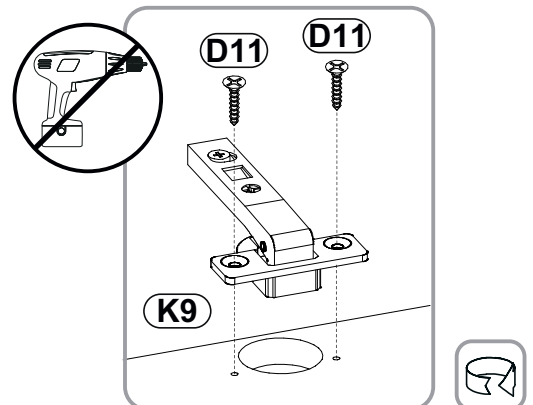
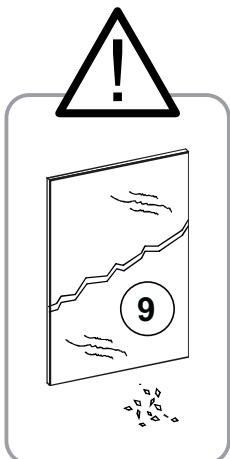
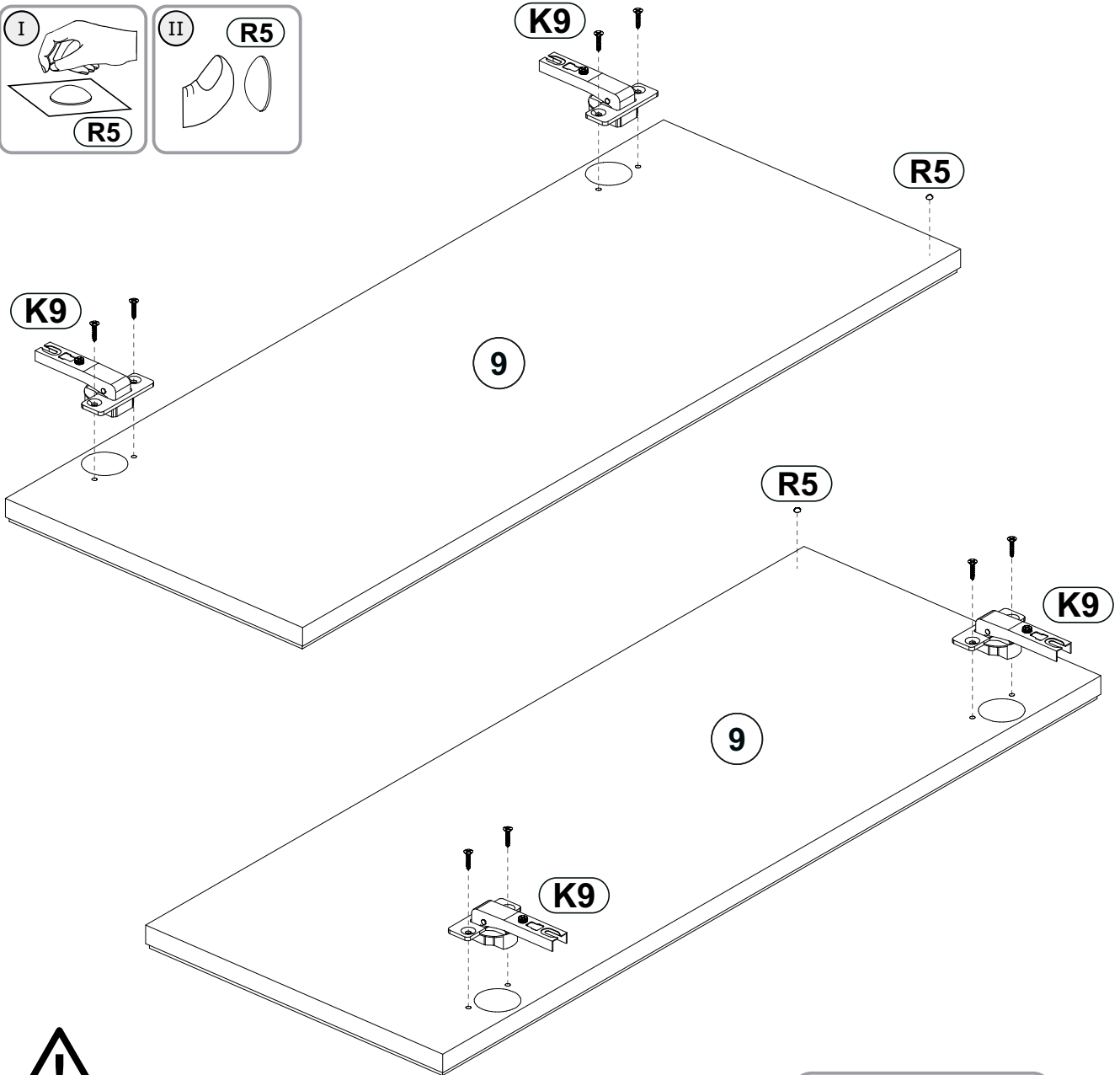
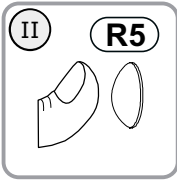
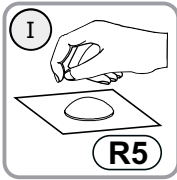

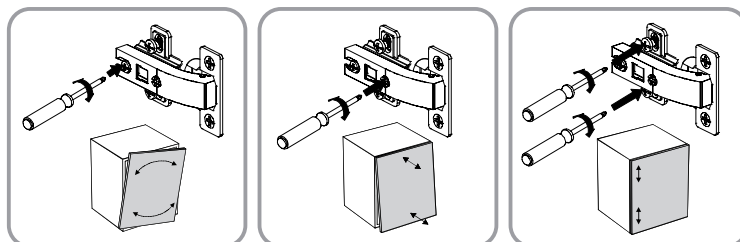
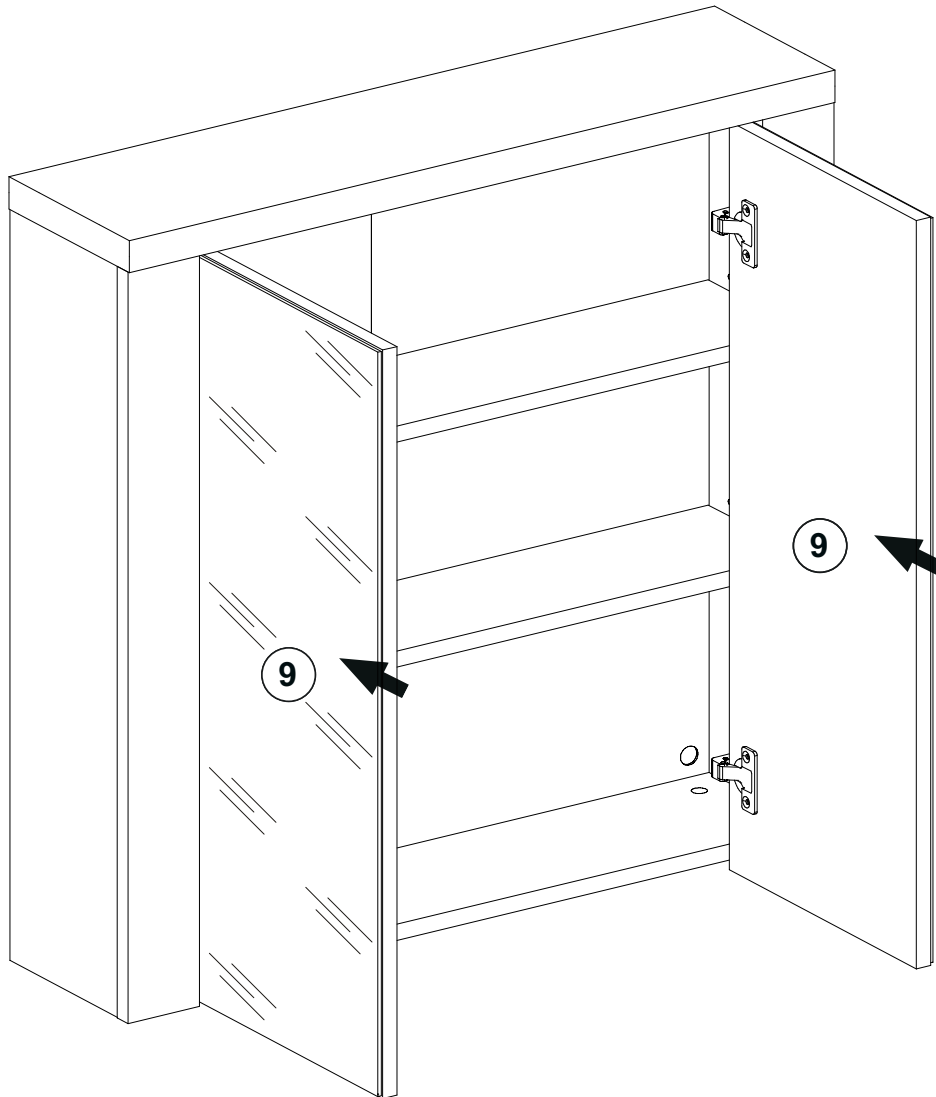
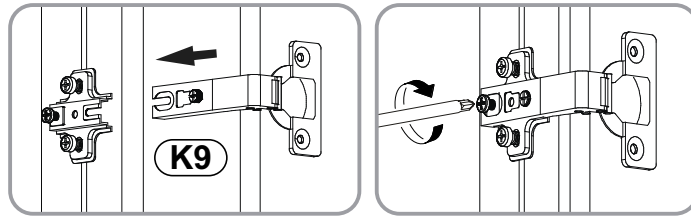

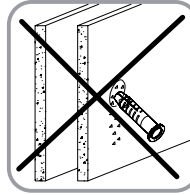
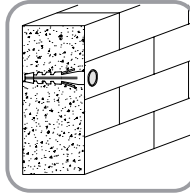

- Y41** 55mm x2
- Y39** 10x50 x2

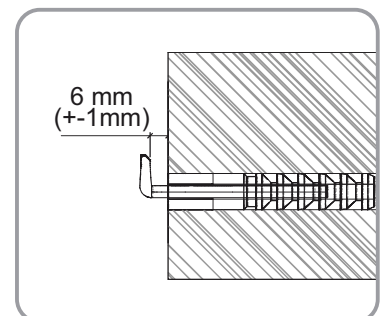
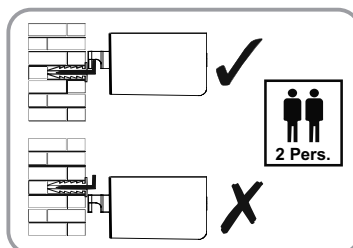
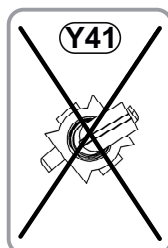
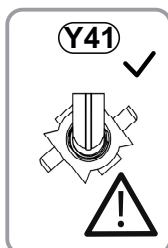
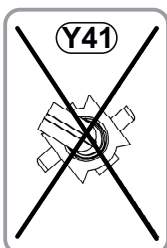
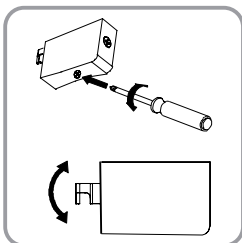
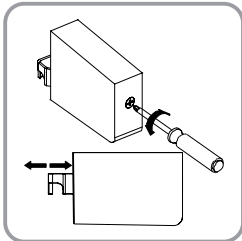
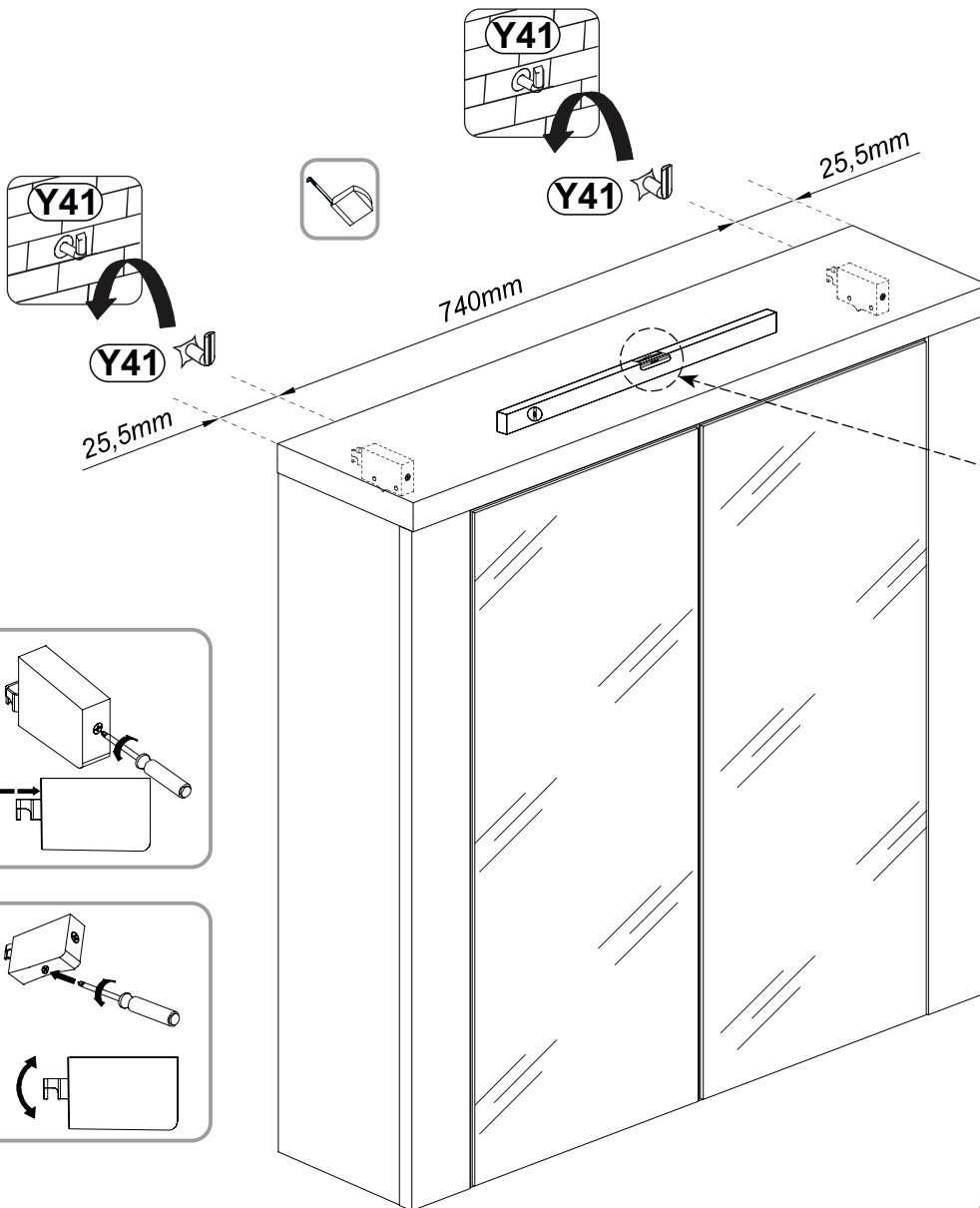
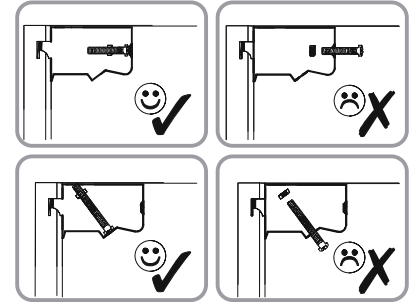
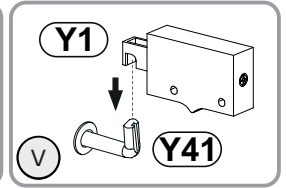
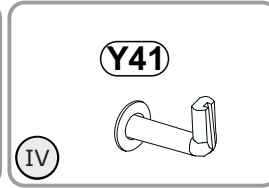
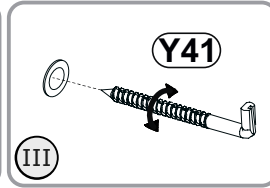
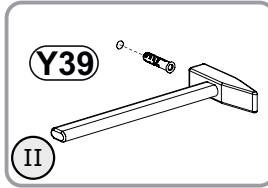
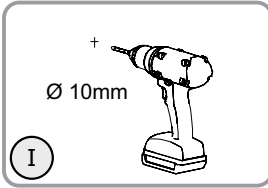

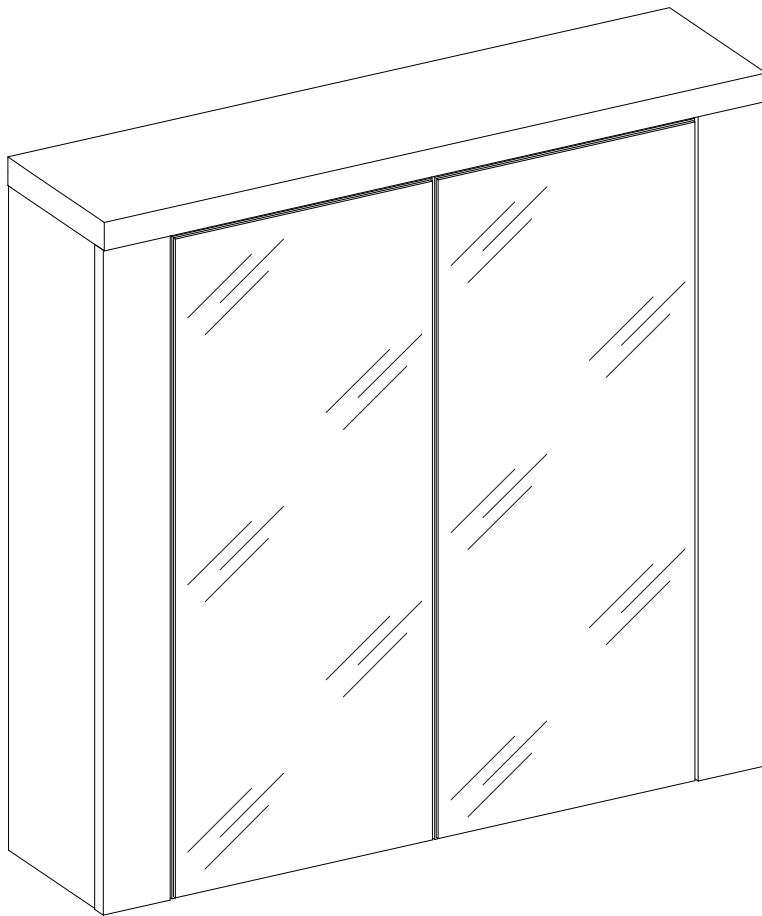

LKZ:80407

Modellname / Model name / Nom du modèle / Modellnamn  
Nome modello / Název modelu / Modelnaam / Ime modela  
Número Modelo / Modell neve / Название модели /  
Názov modelu / Ime modela / Denumire model /  
Наименование на модела / Nazwa modelu

**FOLLOW**

Modellnummer / Number / Numéro du modèle  
Numero / Номер на модела / modello  
Číslo modelu / Modell száma / Éíslo modelu  
Številka modela / Număr model / Broj modela  
Modelnummer / Numer modelu

2228-405-E2

Type / Tipo / Típus / Тип / Тип / Tip

**405**

D

Unser Direktservice für Beschlagteile

Sollte Ihnen ein Beschlagteil fehlen, können Sie diese Servicekarte direkt an die untenstehende Adresse mailen. Wir können allerdings nur Beschlagteile auf diesem Wege verschicken. Sollen Sie eine andere Beanstandung an Ihrem Möbelstück haben, so wenden Sie sich bitte direkt an Ihr Möbelhaus.

Our direct order service for fitting

If a fitting part is missing, you can e-mail this service card directly to the address below. However, we can only send fitting parts in this way. If you have any other cause for complaint concerning your item of furniture, please contact your furniture store directly.

Naše přímé služby pro kování

Chybí-li vám nějaký díl z kování, můžete tuto servisní kartu odeslat e-mailem přímo na níže uvedenou adresu. Touto cestou však můžeme zoslat jen díly kování. Pokud byste reklamovali jiný díl nábytku, obraťte se přímo na svého prodejce nábytku.

Bien étudier la notice de montage

S'il vous manque une ferrure, veuillez envoyer directement la présente carte service à l'adresse e-mail indiquée ci-dessous. Cependant, ceci nous permet uniquement d'envoyer des ferrures. Pour tout autre type de réclamation concernant votre meuble, veuillez contacter directement votre magasin d'ameublement.

Il nostro servizio diretto per l'ordine della ferramenta

Qualora Vi dovesse mancare un pezzo di fissaggio, allora Vi preghiamo di inviare questa carta di servizio immediatamente all'indirizzo sottostante. Possiamo inviare i pezzi di fissaggio solamente per mezzo di questo procedimento. Qualora dovete avere qualche altra reclamazione in merito al mobile, allora Vi preghiamo di rivolgerVi direttamente al Vostro Negozio di mobili.

Нашата директна услуга за обков

Ако липсват части от комплекта, попълнете настоящата сервисна карта и ни я изпратете на e-mail адреса, посочен по-долу. По този начин можем да доставяме само липсващи елементи от обкова. Ако установите други дефекти по мебелите, Ви съветваме да се обърнете към мебелната къща/магазин, от който сте закупили стоката.

Onze directservice voor losse onderdelen

Wanneer er een onderdeel ontbreekt, kunt u deze servicekaart direct aan onderstaand e-mailadres sturen. Wij kunnen langs deze weg echter alleen beslagdelen versturen. Mocht u een ander probleem aan uw meubel hebben, verzoeken wij u contact op te nemen met uw meubeldealer.

Nasz bezpośredni serwis czesci montazowych

Jeżeli brakuje części koniecznych do montażu, prosimy o przesłanie nam niniejszej karty serwisowej na niżej podany adres e-mailowy. W ten sposób możemy przelać Państwu tylko brakujące części. W przypadku innych reklamacji dotyczących mebla, prosimy zgłosić się do salonu meblowego, w którym został dokonany zakup.

Servis za okove

U slučaju da nedostaje neki od dijelova molimo vas da na dolje navedenu mail adresu pošaljete ovaj servisni obrazac. Na ovaj način mogu se dostaviti samo okovi. U slučaju da imate dodatne prigovore vezane uz komad namještaja molimo vas da se obratite izravno trgovini namještaja gdje je isti kupljen.

Direktszolgálatunk vasalatok esetén

Ha hiányzik egy vasalat, ezt a kártyát közvetlenül elküldheti az alább található címre. Azonban csakis vasalatoskat tudunk így küldeni. Amennyiben másfajta reklamáció áll fenn bútordarabját illetően, forduljon közvetlenül a bútortárházhoz.

Náš priamy servis pre časti kovania

Ak by Vám chýbala nejaká časť kovania, môžete poslať túto servisnú kartu poslať e-mailom na nižšie uvedenú adresu. Diely kovania vieme poslať iba týmto spôsobom. Ak by ste mali inú reklamáciu ohľadom Vašho nábytku, obraťte sa priamo na Vašu predajňu nábytku.

Naše direktné uslužne storitve za okovje

Ce vam manjka kakšno okovje, lahko to servisno kartico pošljete po e-pošti direktno na spodnji naslov. Po tej poti vam lahko pošljemo samo okovje. Če želite reklamirati kakšen drug del pohištva, se obrnite neposredno na vašo trgovino pohištva.

Service-ul nostru direct pentru feronerie

În cazul în care vă lipsește o piesă de feronerie puteți să trimiteți direct acest card de service prin e-mail la adresa de mai jos. Noi nu putem expedia piese de feronerie decât pe această cale. Dacă aveți o altă reclamație referitoare la piesa de mobilier, atunci vă rugăm să vă adresați direct la magazinul dvs. de mobilă.

Наш прямой сервис для поставок фурнитуры

Если окажется, что Вам не хватает того или иного элемента фурнитуры, Вы можете отправить сервисную карту по факсу непосредственно на нижеприведенный адрес электронной почты. Однако, таким образом мы можем пересылать лишь фурнитуру. Если же у Вас возникнут иные претензии относительно приобретенной мебели, пожалуйста, обращайтесь непосредственно в организацию, осуществившую продажу.

Vår direktservice för beslagsdelar

Om du saknar en beslagsdel kan du skicka detta servicekort direkt till e-postadressen som anges nedan. Tänk på att detta är den enda möjligheten att skicka beslagsdelar till dig. Om du vill reklamera din möbel av en annan anledning måste du kontakta ditt möbelhus direkt.

Nuestro servicio directo para accesorios

Si le falta algún accesorio, puede enviar esta tarjeta de servicio directamente a la siguiente dirección. No obstante, por este método solo podemos enviar accesorios. Si tiene alguna otra objeción sobre su mueble, consulte directamente con su mueblería.

Donatilar için doğrudan servisimiz

Bir donatınız eksikse bu servis kartını doğrudan aşağıda bulunan adrese doğrudan mail yazabilirsiniz. Sadece bu yolla donatıları gönderebiliriz. Mobilyanızda başka şikayetleriniz varsa lütfen doğrudan mobilya satıcınıza danışın.

GB

CZ

F

I

BG

NL

PL

HR

HU

SK

SLO

RO

RUS

S

ES

TR

## OPTION

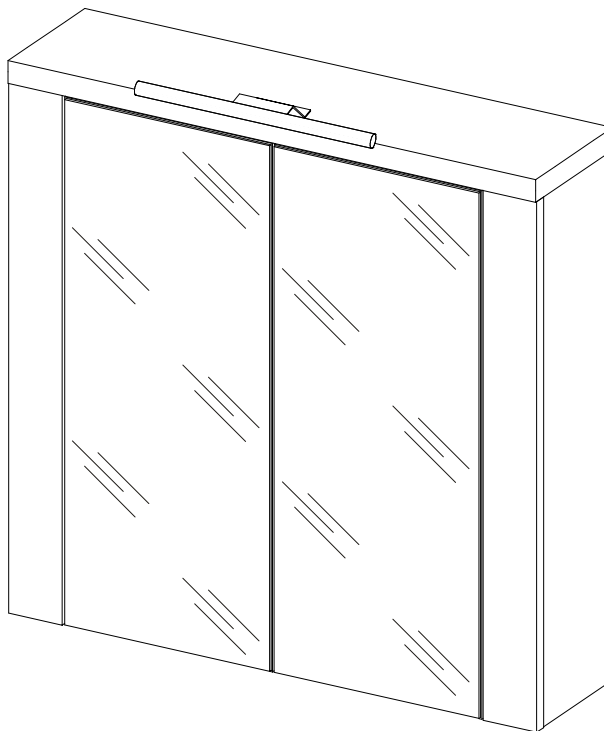

### Type 1100-xxx-00

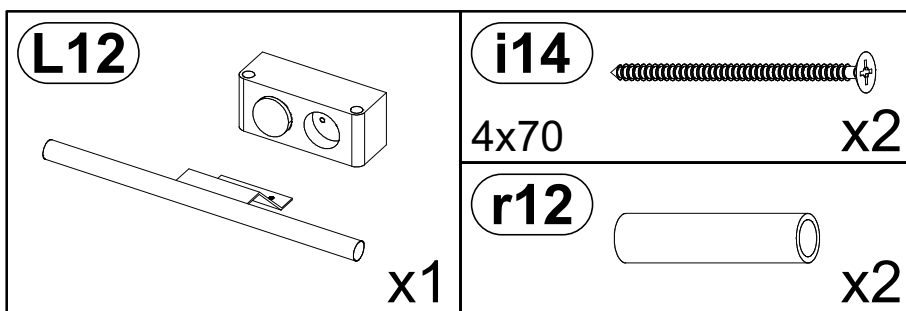

Grund der Beanstandung / Cause for complaint:

Möbelhaus / Furniture store:

Kunde/ Customer:

Telefon / Telephone:

PLZ / Postcode:

Ort / City:

Str. +Nr / Street address:

@E-Mail:

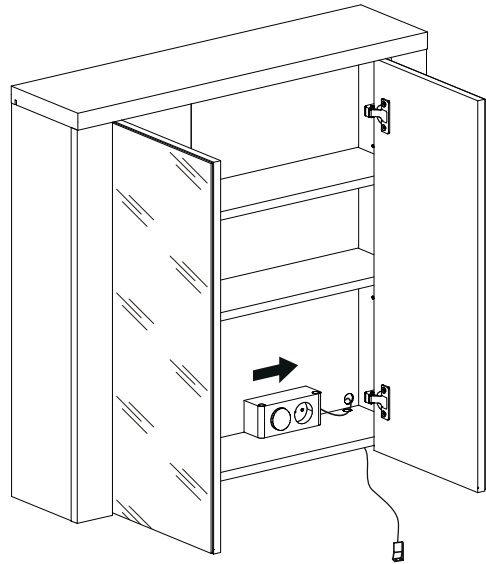
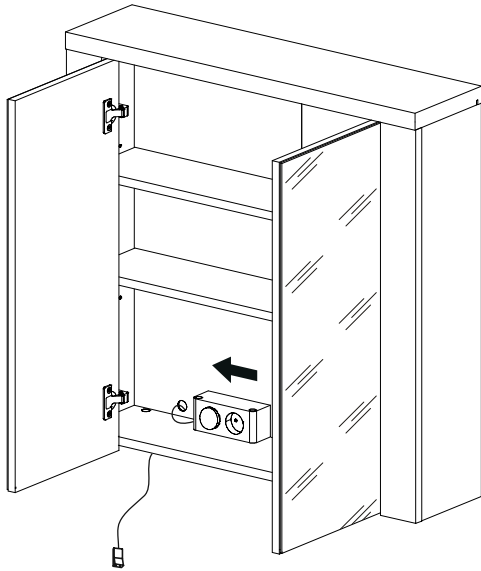
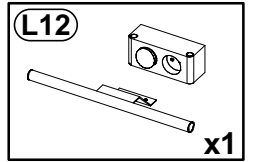
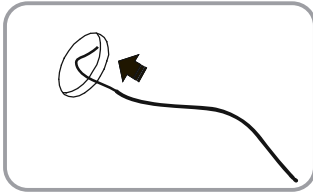
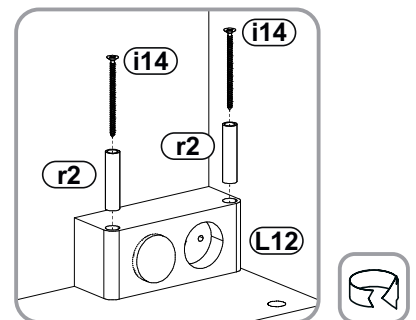
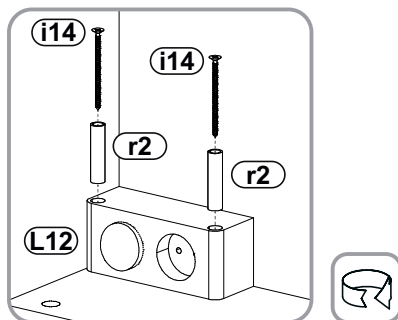
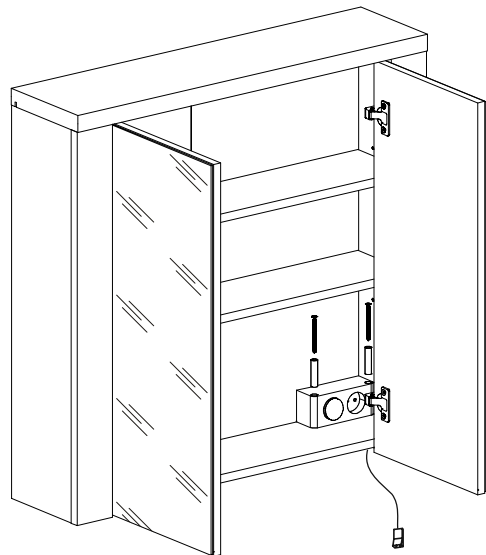
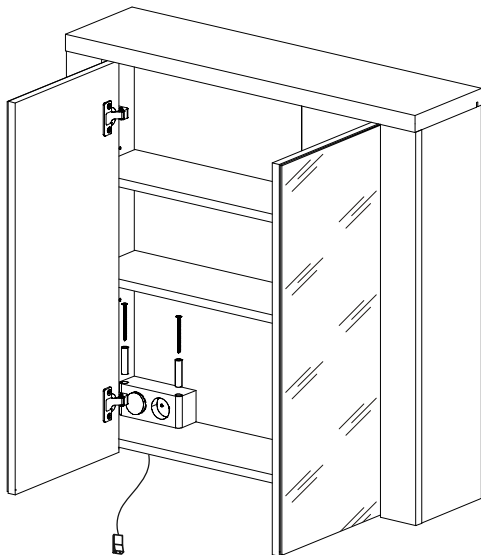
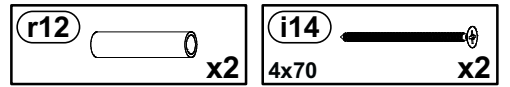
**A****B**

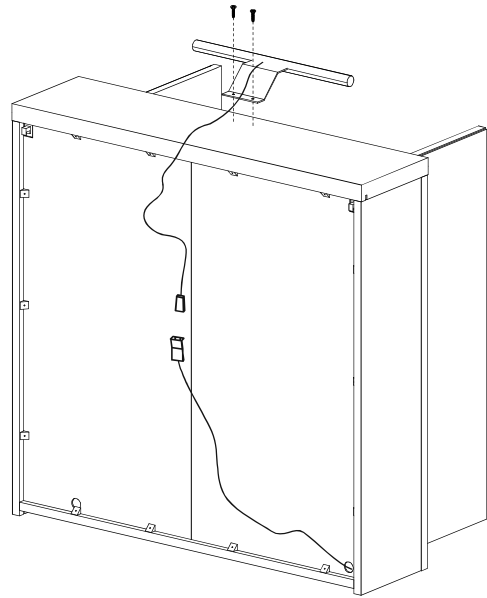
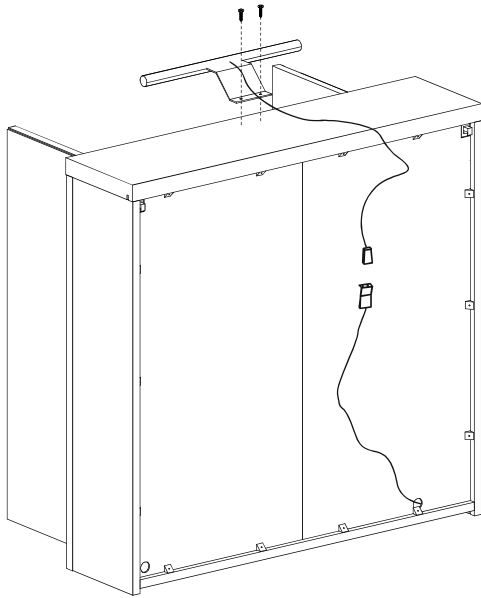
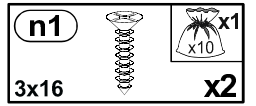
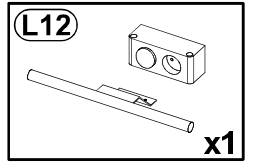
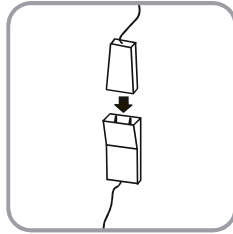
**C****D**