

**INSTRUCTION MANUAL/BEDIENUNGSANLEITUNG/NOTICE D'UTILISATION/  
MANUAL DE INSTRUCCIONES DE USO/MANUALE DI ISTRUZIONI**

ORIGINAL INSTRUCTION MANUAL  
RETAIN FOR FUTURE REFERENCE

---

**EN**

---

**IMPORTANT: PLEASE RETAIN THIS INSTRUCTION MANUAL FOR FUTURE REFERENCE, PLEASE READ CAREFULLY.**

**CLEAN AND CARE**

1. Keep away from heat and fire.
2. Don't let hard metal products or other sharp objects hit the chair. and protect the surface from scratches.
3. Use a special furniture cleaner to clean the seat. Avoid using alcohol, gasoline or other chemical solvents to remove stains for stain cleaning.
4. When there are water marks on the surface of the chair, it needs to be removed immediately with a dry soft cloth.

**ÜBERSETZUNG DER ORIGINALBETRIEBSANLEITUNG  
FÜR KÜNFTIGE VERWENDUNG AUFBEWAHREN**

---

**DE**

---

**WICHTIG: BITTE BEWAHREN SIE DIESE BEDIENUNGSANLEITUNG FÜR ZUKÜNFTIGES NACHSCHLAGEN GUT AUF UND LESEN SIE SIE SORGFÄLTIG DURCH.**

**REINIGUNG UND PFLEGE**

1. Von Hitze und Feuer fernhalten.
2. Vermeiden Sie eine Berührung mit harten Metallen oder anderen scharfen Gegenständen und schützen Sie die Oberfläche vor Kratzern.
3. Verwenden Sie einen speziellen Möbelreiniger, um den Sitz zu reinigen. Vermeiden Sie die Verwendung von Alkohol, Benzin oder anderen chemischen Lösungsmitteln, um Flecken zu entfernen.
4. Wenn sich Wasserflecken auf der Oberfläche des Stuhls befinden, müssen diese sofort mit einem trockenen, weichen Tuch entfernt werden.

**TRADUCTION DU MODE D'EMPLOI ORIGINAL  
A CONSERVER POUR UNE UTILISATION FUTURE**

---

**FR**

---

**IMPORTANT : VEUILLEZ LIRE ATTENTIVEMENT CE MANUEL D'INSTRUCTIONS ET LE CONSERVER SOIGNEUSEMENT POUR UNE RÉFÉRENCE ULTÉRIEURE.**

**NETTOYER ET ENTRETIEN**

1. Tenir à l'écart de la chaleur et du feu.
2. Ne pas laisser d'objets en métal ou pointus heurter le fauteuil et protéger la surface des rayures.
3. Utiliser un nettoyant spécial meuble pour le siège. Éviter d'utiliser de l'alcool, de l'essence ou d'autres solvants chimiques pour enlever les tâches.
4. S'il y a des traces d'eau sur la chaise, il faut les enlever immédiatement avec un chiffon doux et sec.

ES

## IMPORTANTE: CONSERVE ESTE MANUAL DE INSTRUCCIONES PARA FUTURAS REFERENCIAS. LÉALO CON ATENCIÓN.

### LIMPIEZA Y CUIDADO

1. Mantenga la silla lejos del fuego y de los focos de calor.
2. Tenga cuidado de que ningún objeto duro de metal o cortante golpee la silla y proteja la superficie de posibles arañazos.
3. Use un limpiador especial para mobiliario a la hora de limpiar la silla. Evite el uso de alcohol, gasolina u otro disolvente químico para eliminar manchas o suciedad.
4. Cuando perciba marcas de agua en la superficie de la silla, límpielas inmediatamente con un paño seco.

### MANUALE ORIGINALE DI ISTRUZIONI CONSERVARE PER POTERLO CONSULTARE IN FUTURO









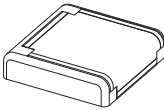

IT

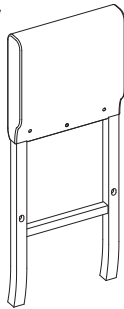
## IMPORTANTE: CONSERVARE QUESTO MANUALE DI ISTRUZIONI PER POTERLO CONSULTARE IN FUTURO, LEGGERLO ATTENTAMENTE.

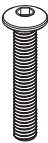
### PULIZIA E CURA

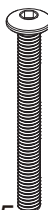
1. Tenere lontano dal calore e dalle fiamme.
2. Non far sbattere prodotti duri in metallo o oggetti taglienti contro la sedia e proteggere la superficie da graffi.
3. Utilizzare liquido per mobili apposito per pulire la sedia. Evitare di utilizzare alcol, benzina o altri solventi chimici per rimuovere macchie o per la pulizia.
4. Quando la superficie della sedia si bagna con acqua rimuoverla immediatamente con un panno asciutto morbido.

### PARTS LIST/STÜCKLISTE/PARTS LIST/LISTA DE PIEZAS/LISTA DEI PEZZI

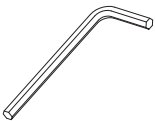
<p><b>A</b></p>  <p>1pc</p>	<p><b>B1</b></p>  <p>1pc</p>	<p><b>B2</b></p>  <p>1pc</p>	<p><b>C</b></p>  <p>1pc</p>	<p><b>D</b></p>  <p>336mm 1pc</p>	<p><b>E</b></p>  <p>380mm 2pcs</p>	
<p><b>G</b></p>  <p>M6x35 6pcs</p>	<p><b>H</b></p>  <p>M6x50 3pcs</p>	<p><b>I</b></p>  <p>M6x55 4pcs</p>	<p><b>J</b></p>  <p>7pcs</p>	<p><b>K</b></p>  <p>7pcs</p>	<p><b>L</b></p>  <p>6pcs</p>	<p><b>M</b></p>  <p>1pc</p>

# ASSEMBLY/MONTAGE/ASSEMBLAGE/MONTAJE/ASSEMBLAGGIO



**Warning!**  
**Warnung!**  
**Attention !**  
**Atención!**  
**Avvertimento!**

Tight all the screws to 60% first then tight to 100%.  
 Während der Montage alle Schrauben zuerst 60% anziehen, dann zu 100%.  
 Serrez toutes les vis à 60% d'abord puis serrez à 100%.  
 Primero apriete los tornillos al 60% y después al 100%.  
 Stringere le viti dapprima al 60% e successivamente completamente al 100%.

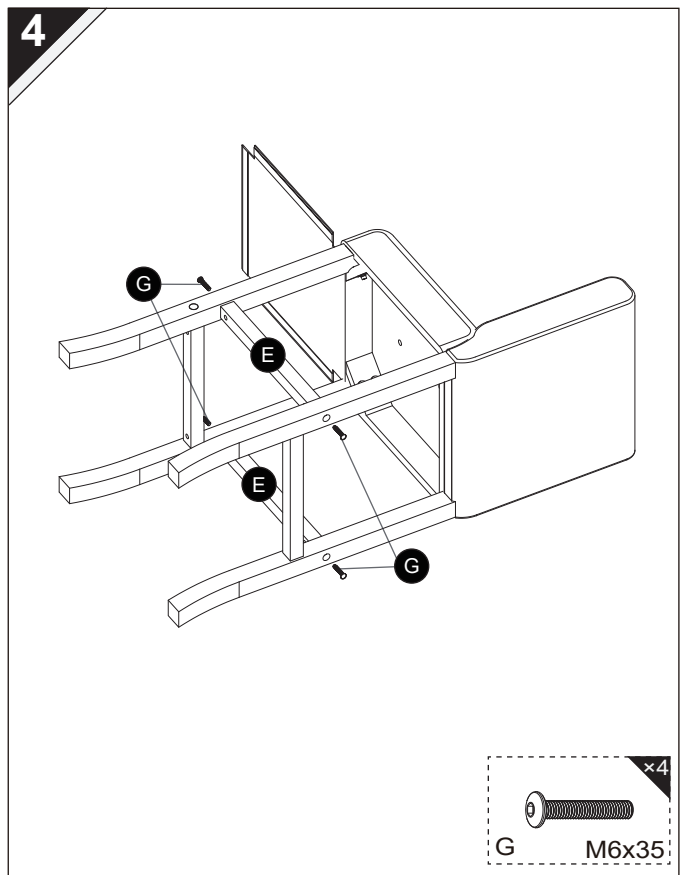
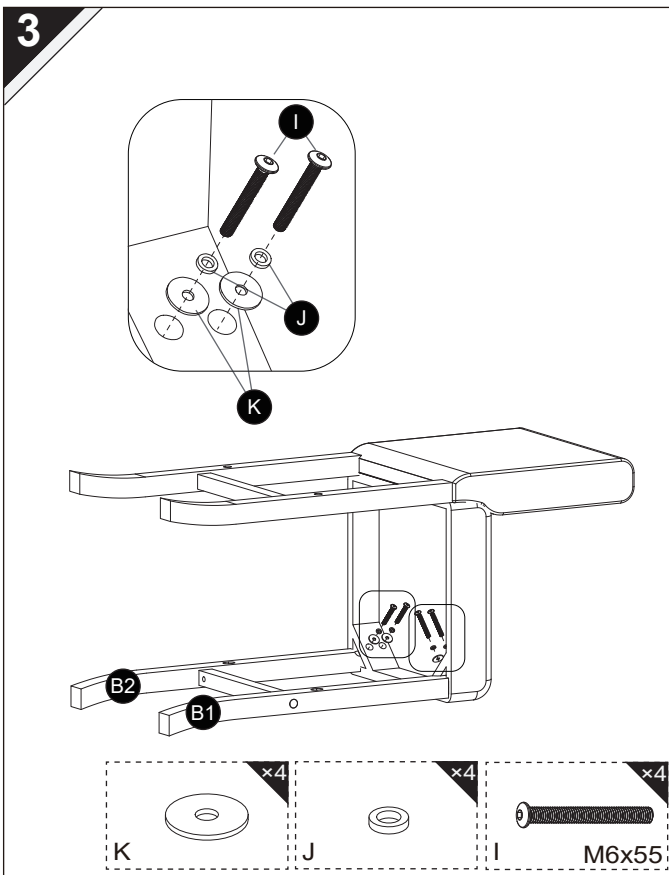
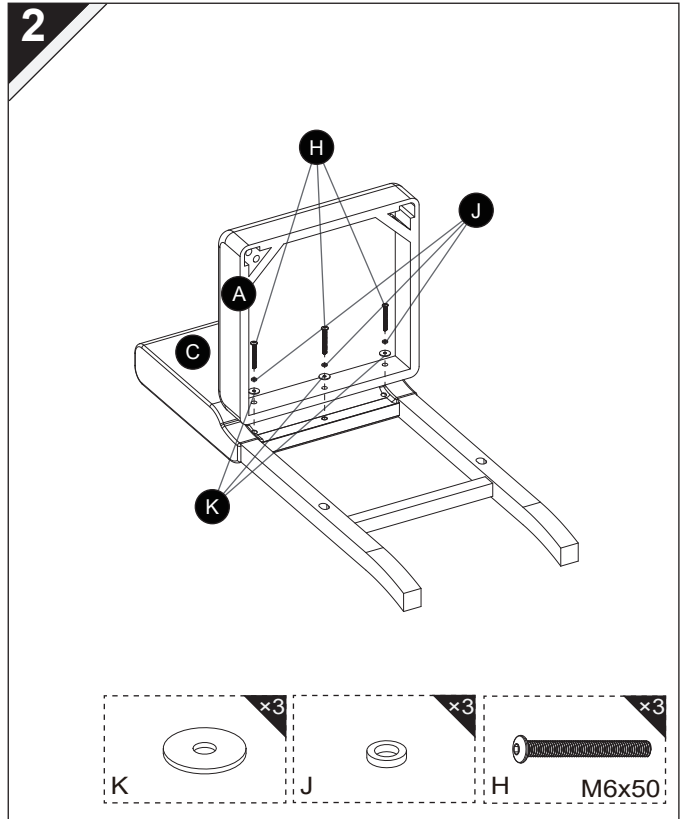
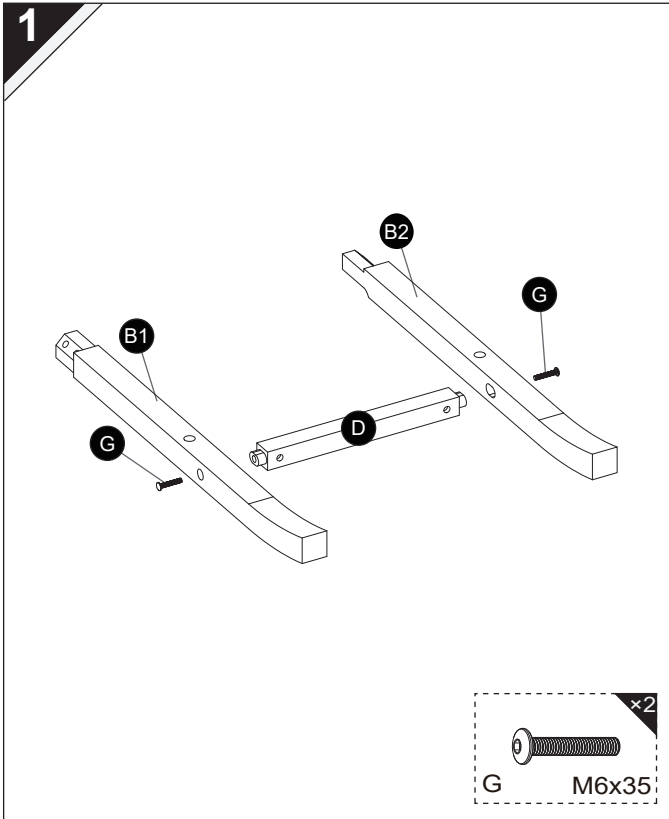



**Warning!**  
**Warnung!**  
**Attention !**  
**Atención!**  
**Avvertimento!**

Tight all the screws to 60% first then tight to 100%.  
Während der Montage alle Schrauben zuerst 60% anziehen, dann zu 100%.  
Serrez toutes les vis à 60% d'abord puis serrez à 100%.  
Primero apriete los tornillos al 60% y después al 100%.  
Stringere le viti dapprima al 60% e successivamente completamente al 100%.

5

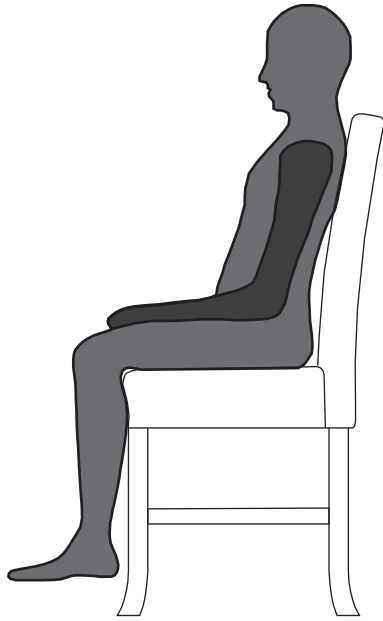

Then adjust the balance of the chair.

Stellen Sie dann das Gleichgewicht des Stuhls ein.

Ajustez ensuite l'équilibre de la chaise.

A continuación, ajuste la silla para que se mantenga equilibrada.

Quindi regolare l'equilibrio della sedia.

6

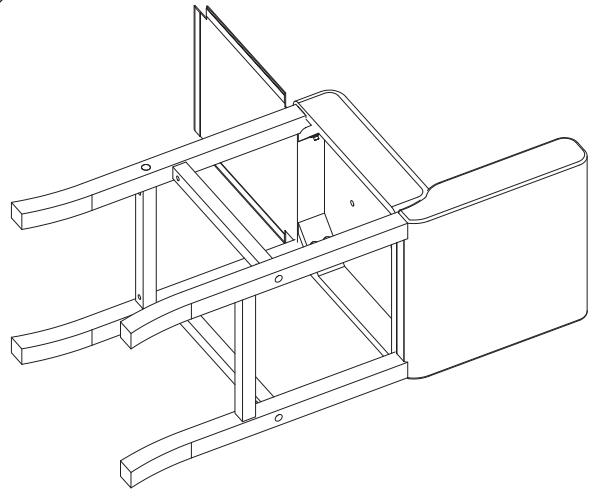

Tight all the screws to 100%

Ziehen Sie alle Schrauben 100 % fest.

Serrez toutes les vis à 100 %

Atornille todos los tornillos al 100%

Stringere tutte le viti al 100%

7

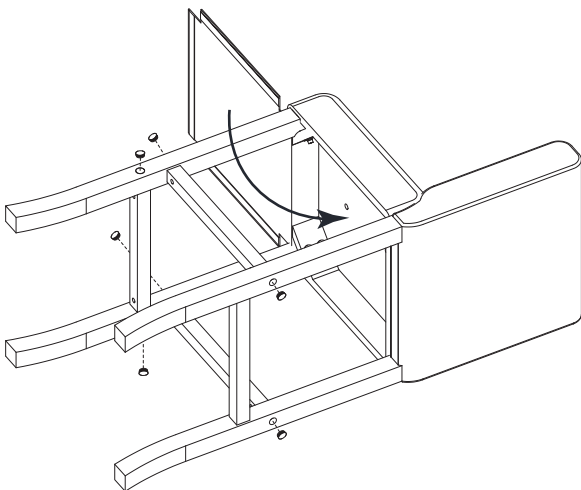

8

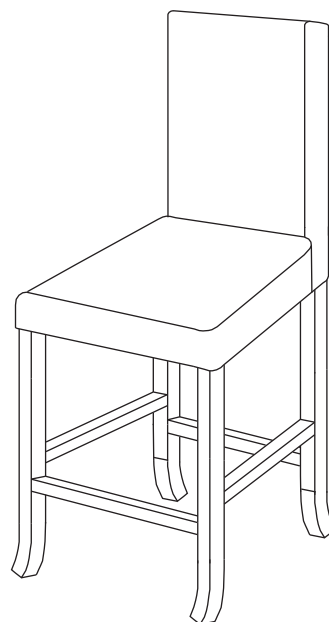

RETAIN FOR FUTURE REFERENCE  
FÜR KÜNFTIGE VERWENDUNG AUFBEWAHREN  
A CONSERVER POUR UNE UTILISATION FUTURE  
CONSERVAR PARA SER LEÍDO POR CADA NUEVO USUARIO,  
ANTES DE UTILIZAR EL ARTÍCULO POR PRIMERA VEZ  
CONSERVARE PER CONSULTAZIONI FUTURE