

Assembly Instructions

WF325208

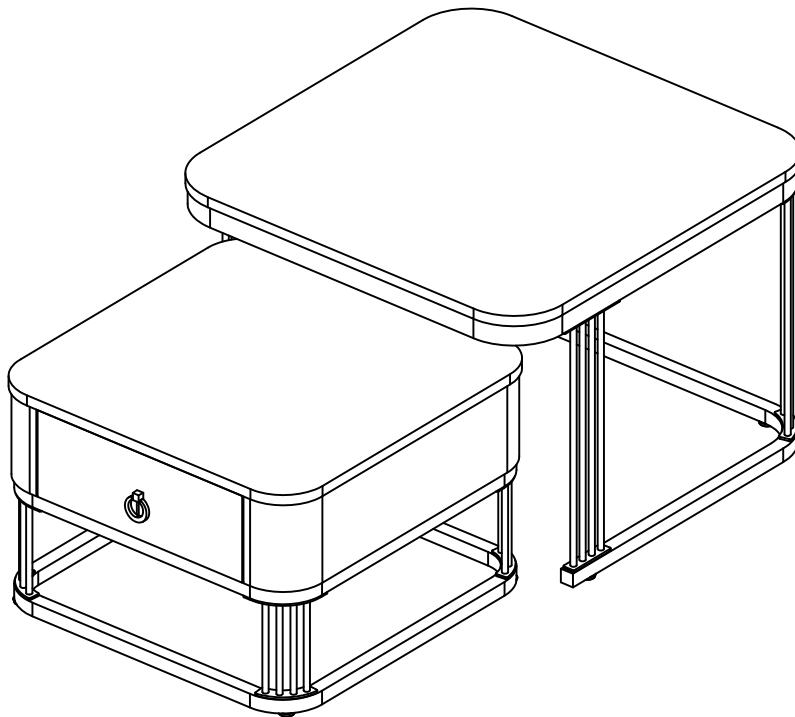

Werkzeug Phillips-schraubendreher
tool phillips head screwdriver



Montagedauer 1 Stunde 30 Minuten
assembling time 1 hour 30 minutes

Achtung!



- 1-Lesen Sie bitte sorgfältig unsere Montageanleitung, bevor Sie anfangen Ihr Produkt aufzubauen.
- 2-Der Aufbau Ihres Produktes soll auf einer sauberen und glatten Oberfläche durchgeführt werden. Wir empfehlen Ihnen die Verpackungskartons zu nutzen, um den Boden, auf dem die Montage stattfinden wird, zu abdecken.
- 3-Kontrollieren Sie bitte die Schrauben regelmäßig und bei Bedarf ziehen Sie erneut die Schrauben, die eventuell nicht mehr so fest sind.
- 4-Vermeiden Sie bitte den Kontakt zwischen scharfen Gegenständen und Ihrer Möbeloberfläche.
- 5-Bitte vermeiden Sie Stöße gegen Ihre Möbeloberfläche.

Attention!





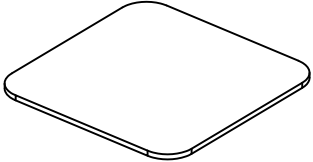
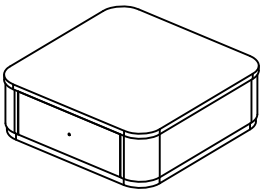
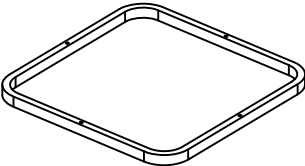

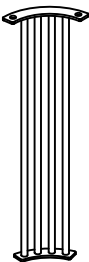
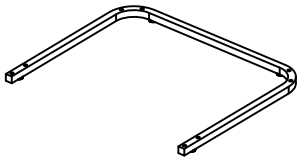
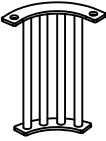
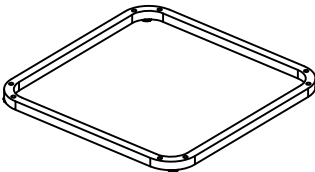
- 1-Please read the assembly instructions very carefully before assembling your product.
- 2-The product assembly has to be carried out on a clean and flat surface. We recommend the use of the packaging material (cartons/cardboards) to cover your room surface during assembly in order to protect the floor.
- 3-The screws and bolts of your furniture have to be tightened periodically.
- 4-Please avoid contact to sharp objects.
- 5-Please avoid hitting the furniture surface.

WF325208

Part List

			
<p>① x1PC</p>	<p>② x1PC</p>	<p>③ x1PC</p>	<p>④ x2PCS</p>
			
<p>⑤ x2PCS</p>	<p>⑥ x1PC</p>	<p>⑦ x4PCS</p>	<p>⑧ x1PC</p>

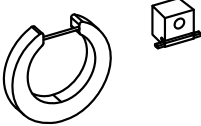
Hardware

 <p>M4</p>	 <p>M6*10mm</p>	 <p>M6*30mm</p>
<p>A x1PC</p>	<p>B x16PCS</p>	<p>C x16PCS</p>
 <p>M6*40mm</p>		 <p>M4*23mm</p>
<p>D x4PCS</p>	<p>E x1PC</p>	<p>F x1PC</p>

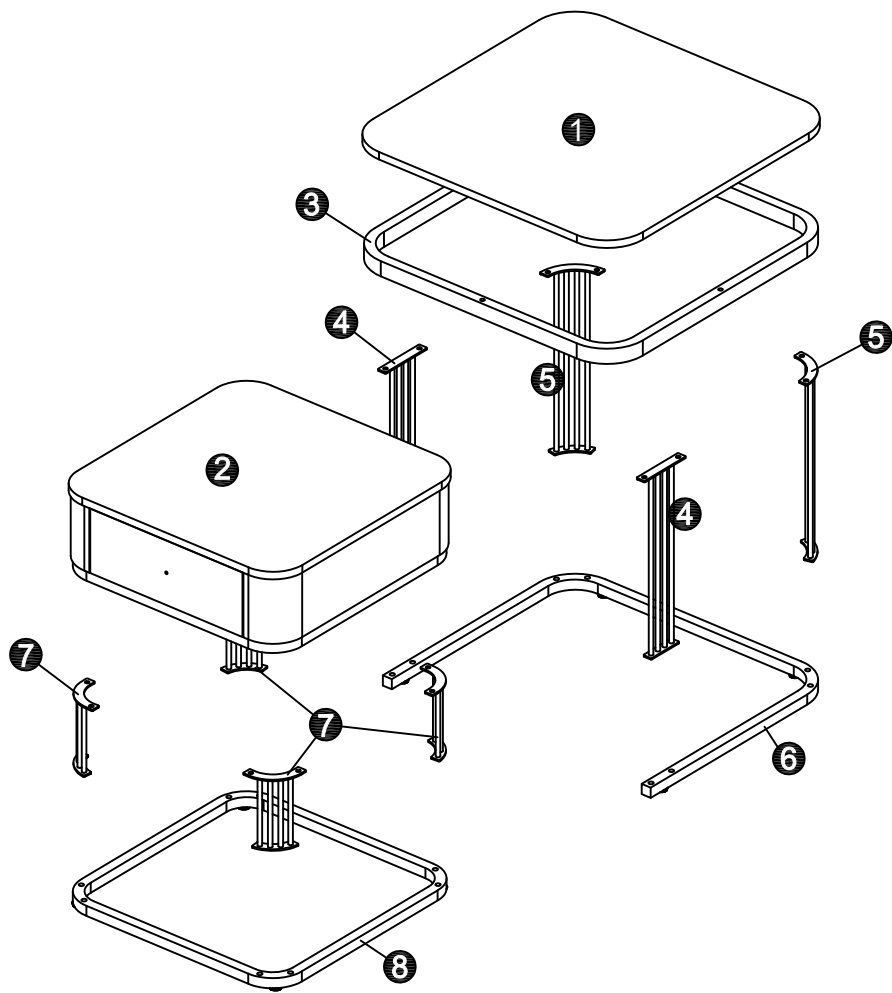

Step 1

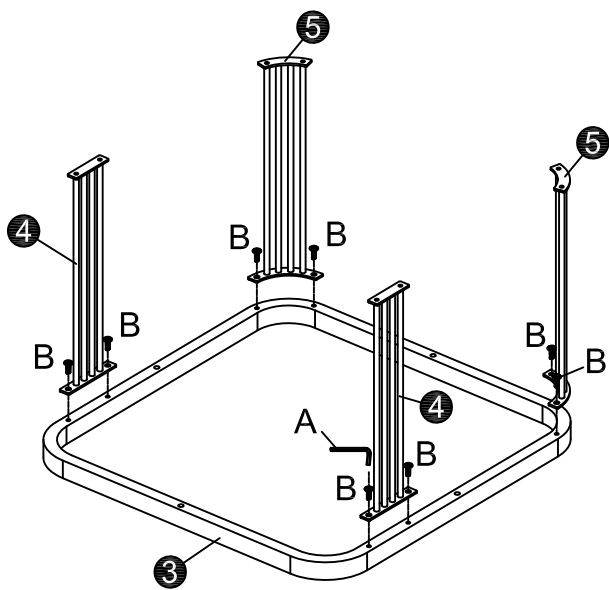

A		1PC
B		8PCS

Step 2

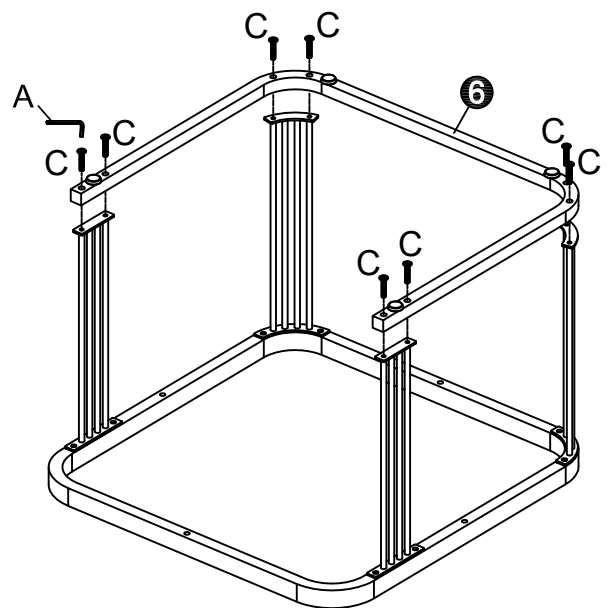

A		1PC
C		8PCS

Step 3

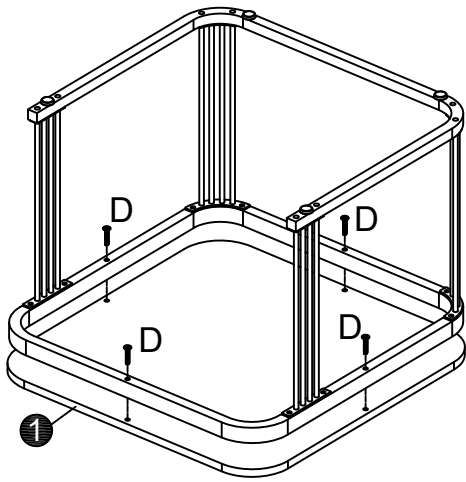

D 4PCS

Step 4

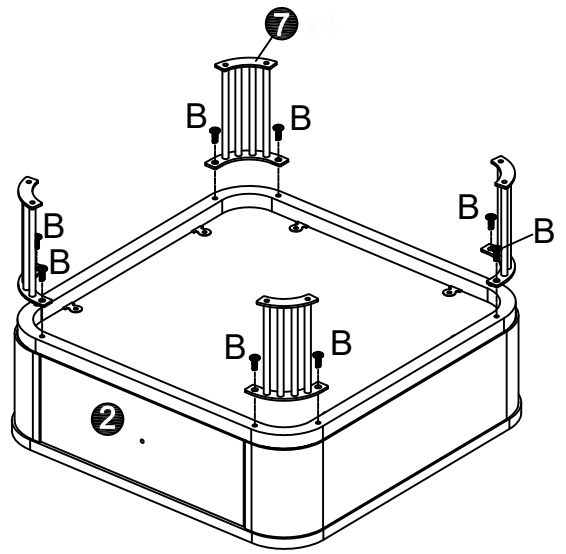

B 8PCS

Step 5

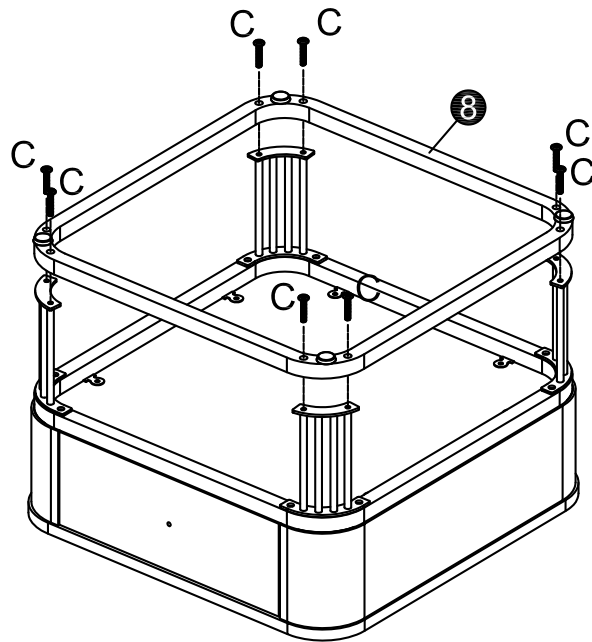

C 8PCS

Step 6

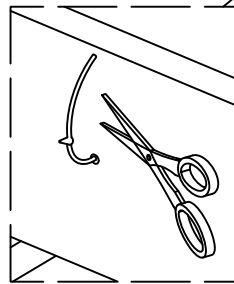
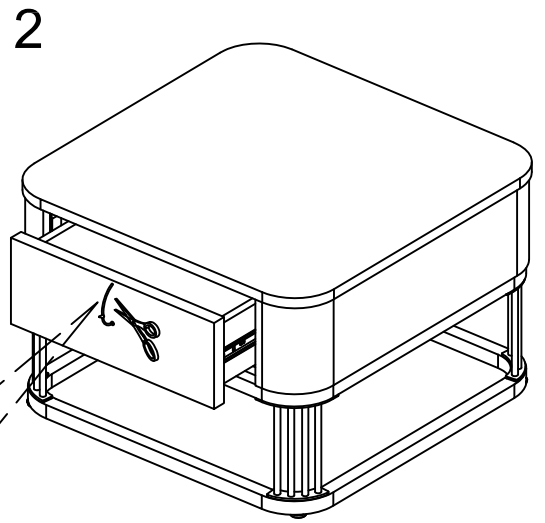
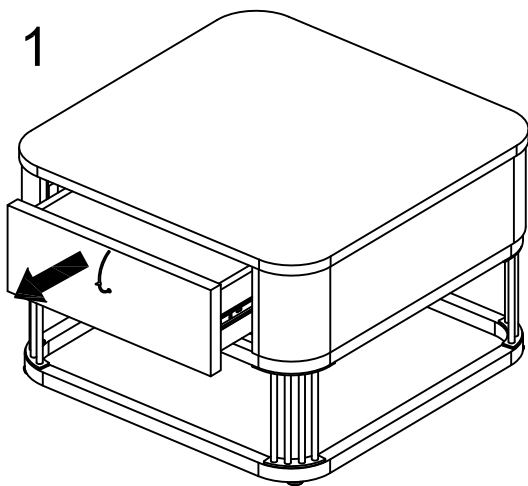

3

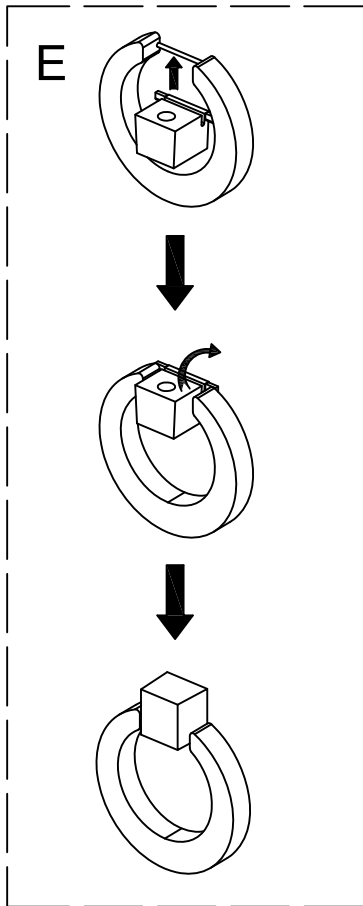
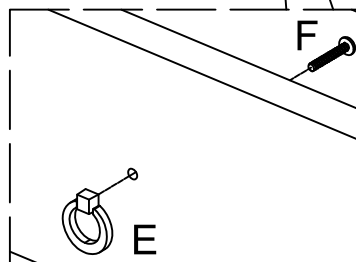
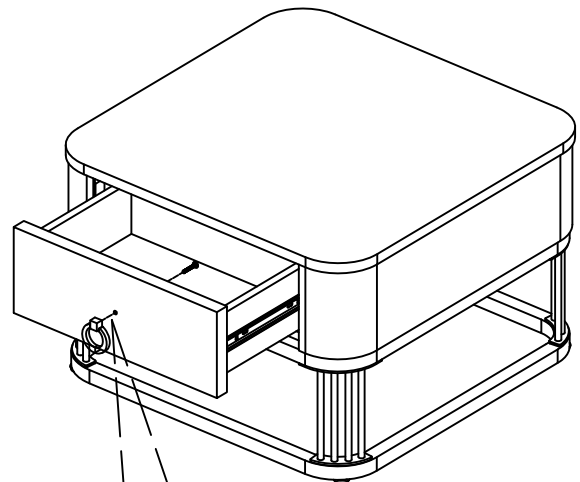

E		1PC
F		1PC