

6008

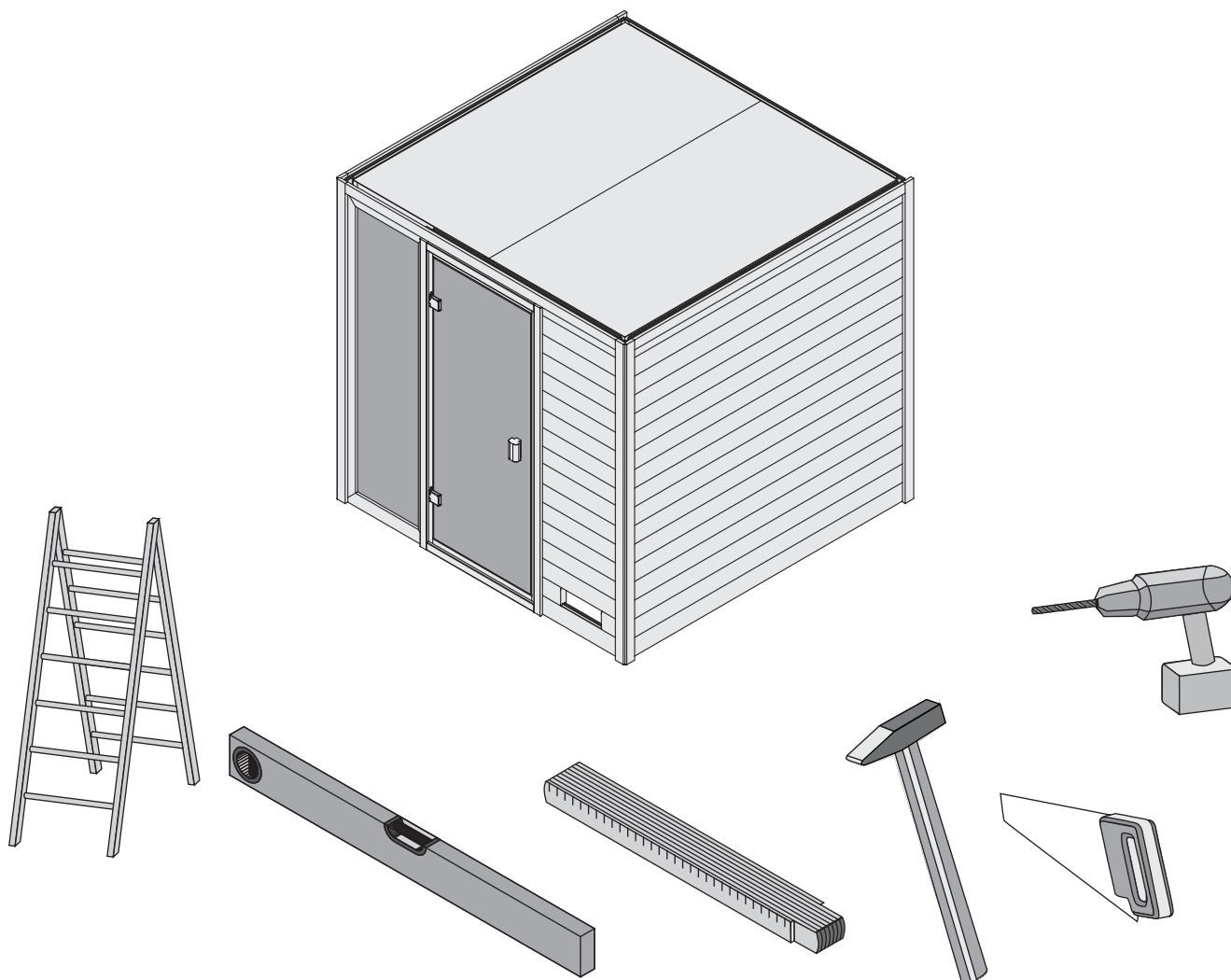

 **Aufbauanleitung**

 **Building Instructions**

 **notice de montage**

 **montagehandleiding**

 **Montagevejledning**

 **Instrucciones de construcción**

 **Istruzioni per il montaggio**

 **Montážní návod**



+49 421 38693 33



Vergleichen Sie zuerst die Material-liste mit Ihrem Paketinhalt! Bitte haben Sie Verständnis, dass Beanstandungen nur im nicht aufgebauten Zustand bearbeitet werden können!



Vergelijk eerst de lijst van materialen met de inhoud van uw pakket! Reclamaties kunnen alleen in behandeling worden genomen zolang de onderdelen nog niet zijn gemonteerd!



Confrontate questa distinta materiali prima con il contenuto del pacchetto! Vi preghiamo di comprendere che eventuali reclami possono essere accolti solo prima del montaggio!



First compare the list of materials with your package contents! Please understand that complaints can be processed in the non-built status only!



Start med at kontrollere materialelisten med indholdet af den leverede pakke! Vi gør venligst opmærksom på at reklamationer kun kan behandles for materialer som ikke er blevet bearbejdet!



Nejprve přezkontrolujte obsah balení podle materiálového listu! Mějte pochopení pro to, že případnou reklamaci se můžeme zabývat pouze tehdy, když díly nebudou smontované! Za pomoci tohoto seznamu můžete jednotlivé díly přiřadit k montážnímu návodu.



Commencez par comparer la liste du matériel avec le contenu de votre paquet! Sachez que nous traitons uniquement les réclamations concernant le matériel à l'état non monté!



En primer lugar, compare la lista de material con el contenido del paquete. Rogamos entienda que las reclamaciones sólo pueden ser tramitadas antes de montar el objeto!

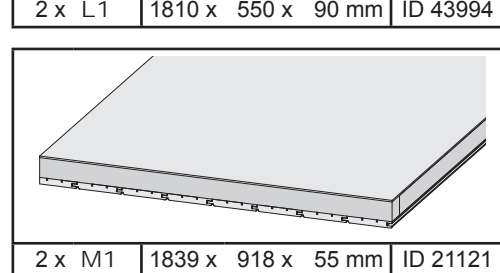
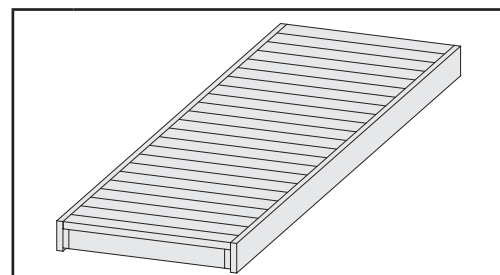
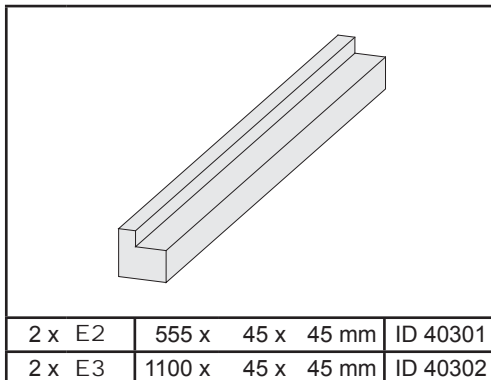
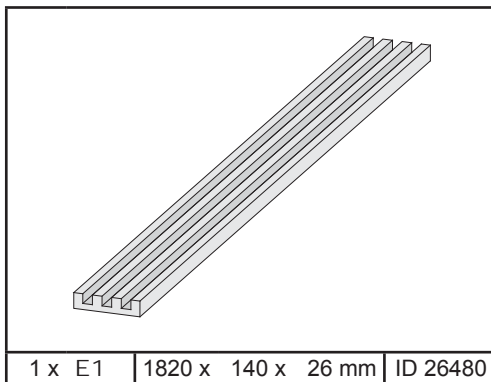
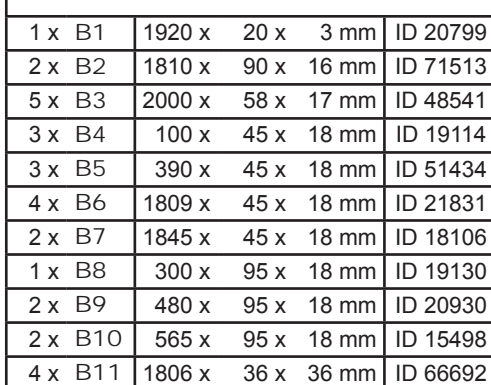
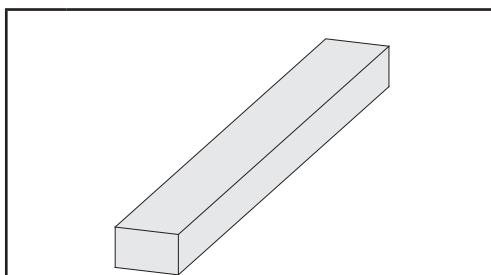
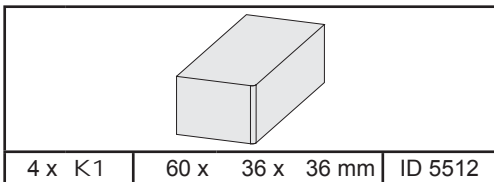
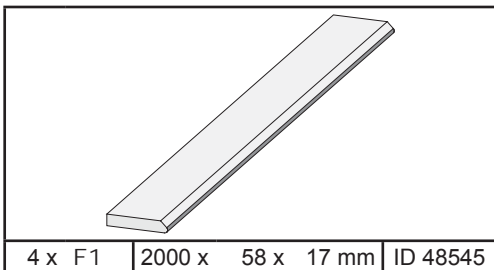
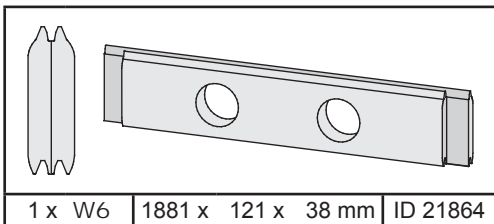
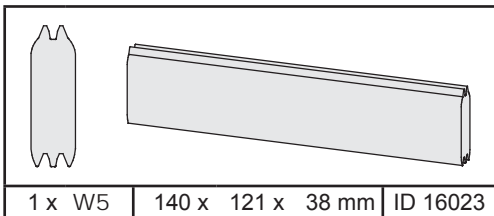
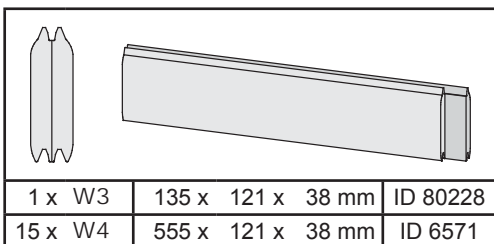
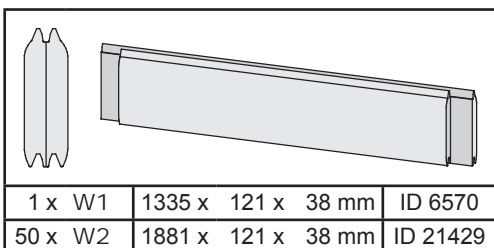
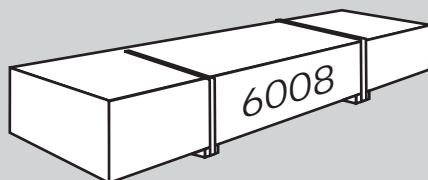

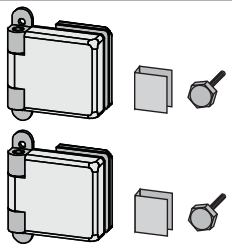

1 x ID 26496

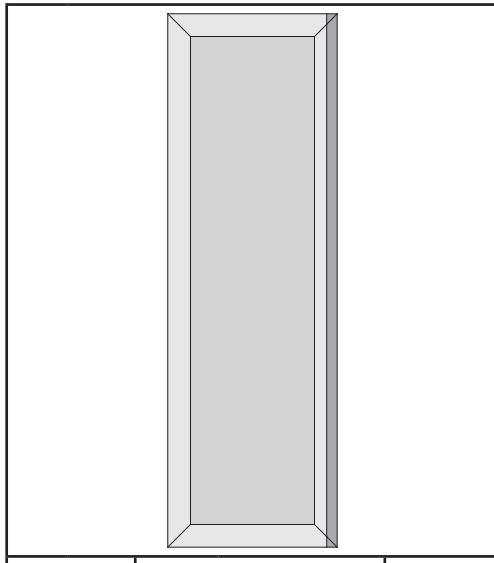

1 x H1 ID 6243

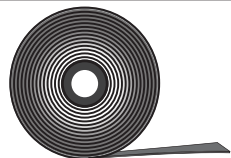

10m ID 14025

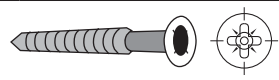

60 x 4,5 x 40 mm ID 26285

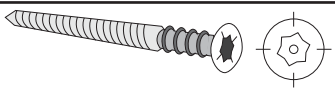

6 x S1 ID 14266



60 x S2 4,5 x 30 mm ID 26116
6 x S3 12 x 18 mm ID 46403

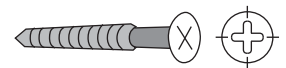

40 x	4 x 30 mm	ID 3686
60 x	4 x 35 mm	ID 3687
350 x	4 x 40 mm	ID 21925
40 x	4 x 50 mm	ID 3688
25 x	4 x 70 mm	ID 3689
25 x	4,5 x 80 mm	ID 9204
20 x	6 x 60 mm	ID 14014
95 x	6 x 90 mm	ID 26715

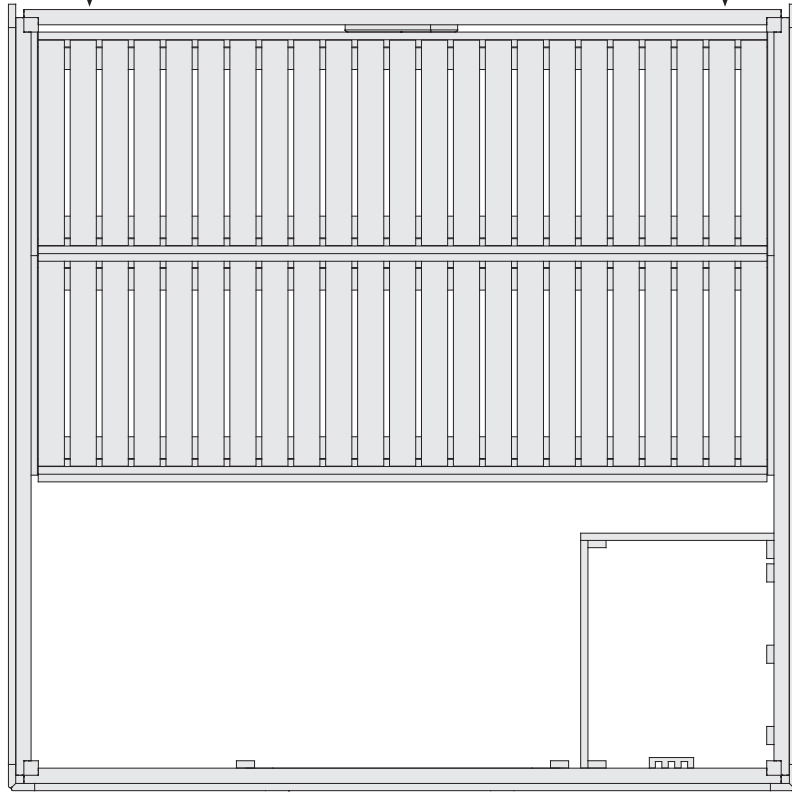
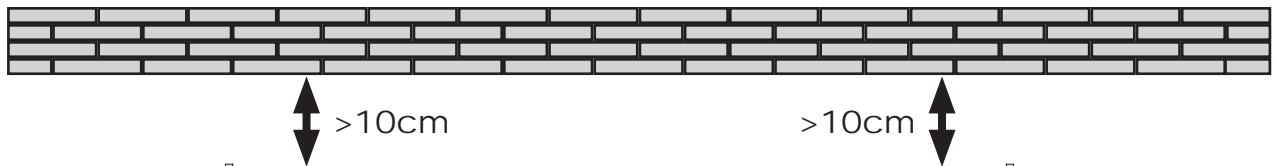

-  Draufsicht
-  Top view
-  vue de dessus
-  bovenaanzicht
-  vista desde arriba
-  vista desde arriba
-  vista dall'alto
-  púďorys

Bitte beachten Sie, dass es sich bei einem Spontanbruch infolge von Nickelsulfideinschlüssen um Glasbrüche handelt, die nicht auf Verarbeitungsfehler basieren und somit nicht durch den Hersteller und dem Verarbeiter zu vertreten sind. Der Spontanbruch ist als hinzunehmendes Allgemeinrisiko anzusehen.

Bitte haben Sie Verständnis, dass wir eine Nachlieferung nur gegen Berechnung ausführen können.

M 1

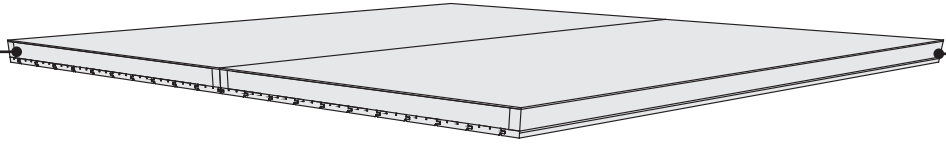

B 6

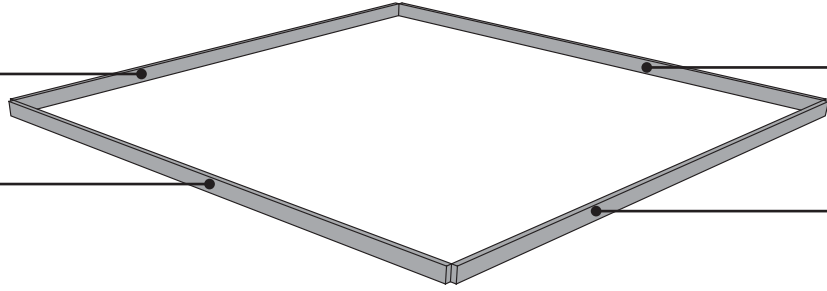

B 6

B 3

B 11

B 3

F 1

W 2

B 11

L 1

B 2

L 1

B 2

W 1

B 7

F 1

B 3

B 7

H 1

W 4

F 1

D 1

W 2

B 11

B 8

B 3

E 2

B 3

K 1

E 3

B 9

B 5



E 1



W 1

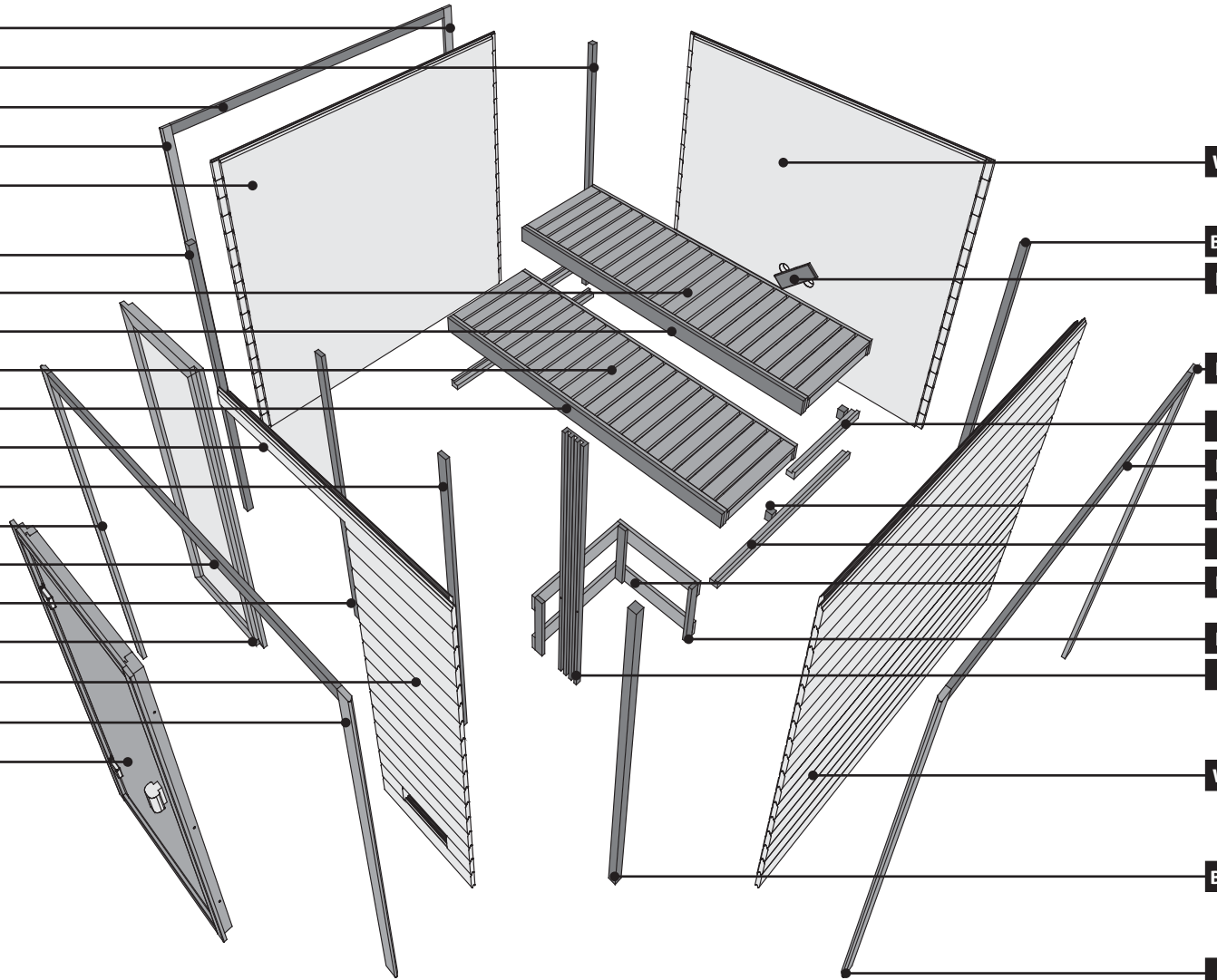

B 11

F 1



 Achten Sie auf die gleiche Höhe
 Look for the same height
 Faites attention à la même hauteur

 Besteed aandacht aan de dezelfde hoogte
 Prestar atención a la misma altura
 Prestare attenzione alla stessa altezza

 Dávejte pozor na stejnou výšku
 Vær opmærksom på samme højde

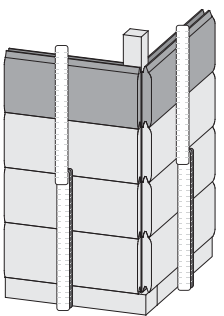
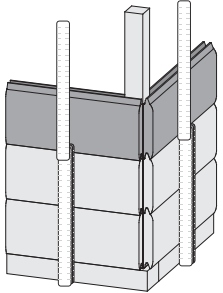
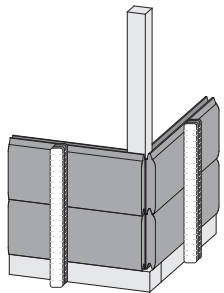

01

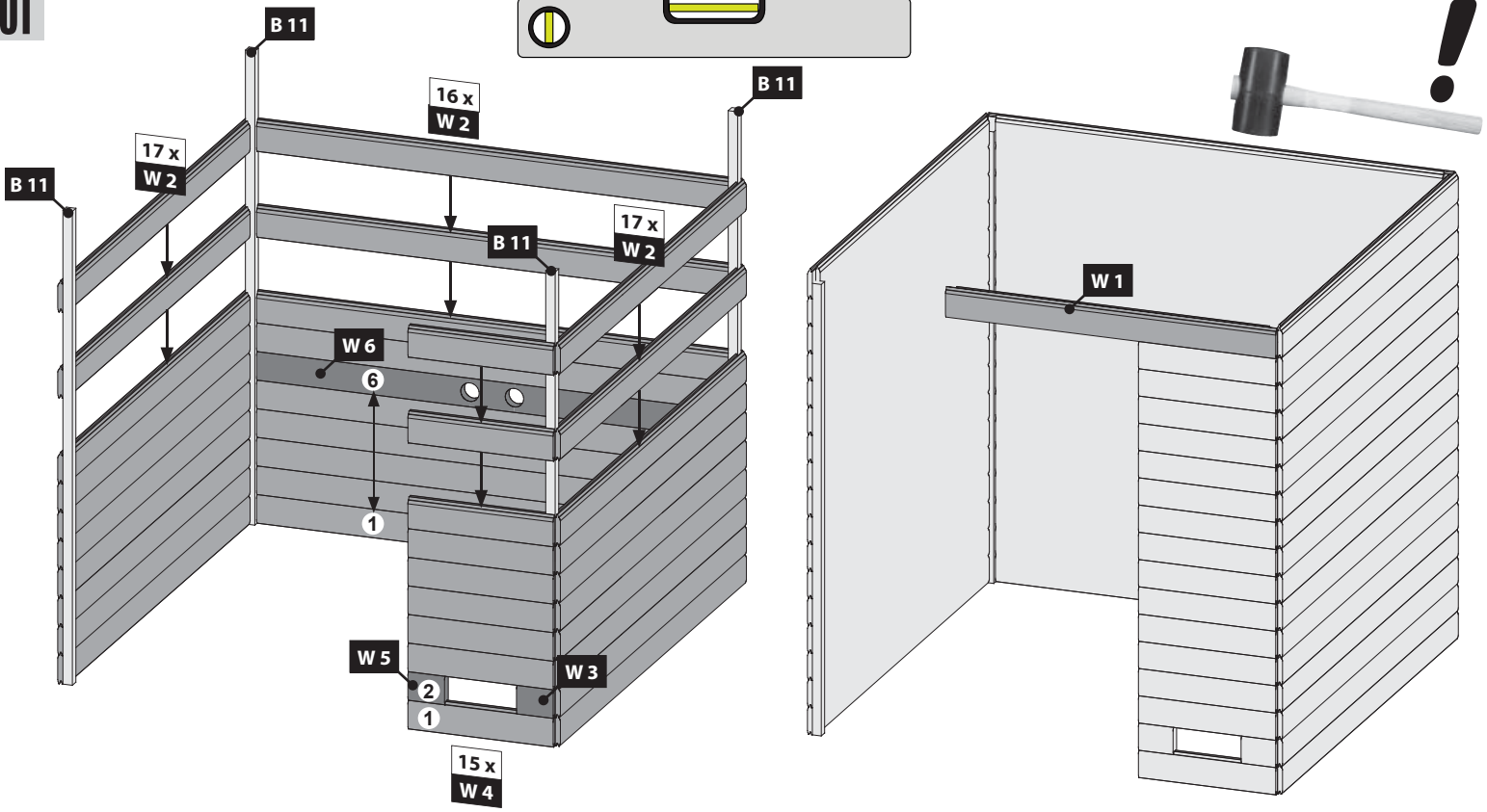

02

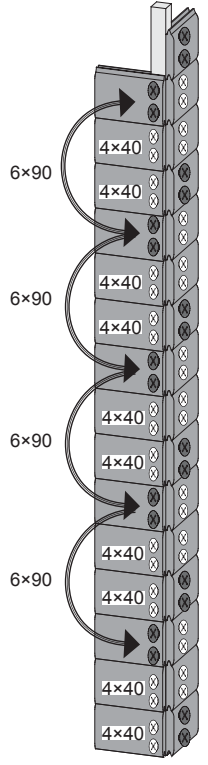
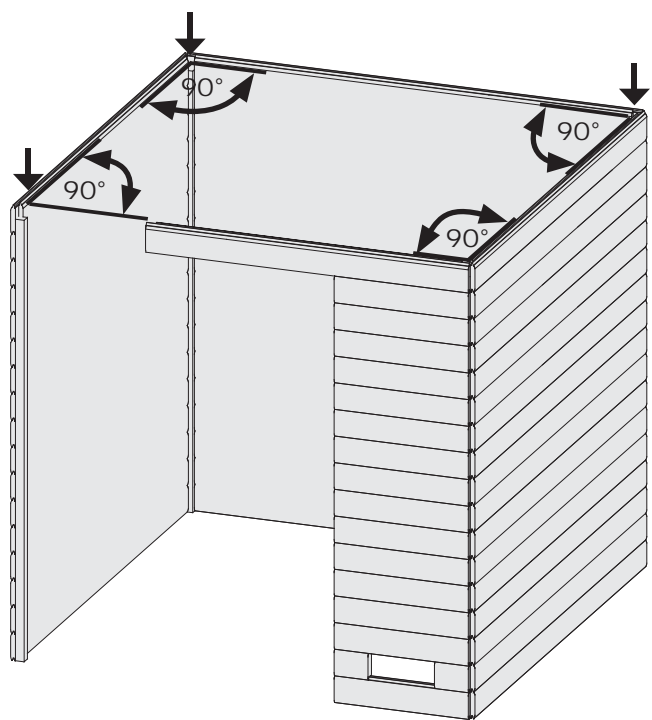
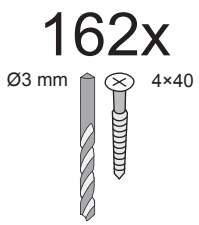
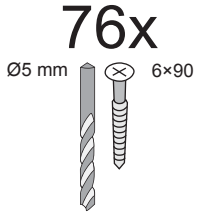
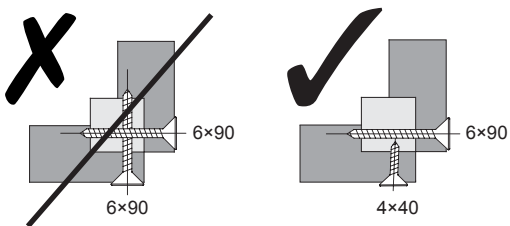

Ø3 mm 4x30

34x

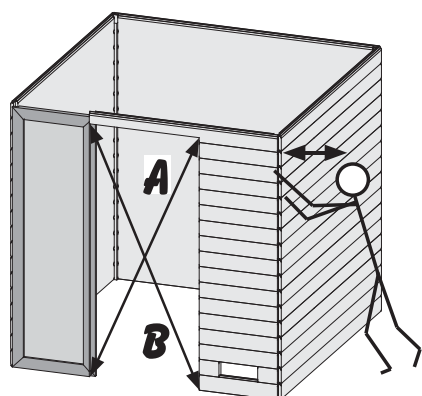
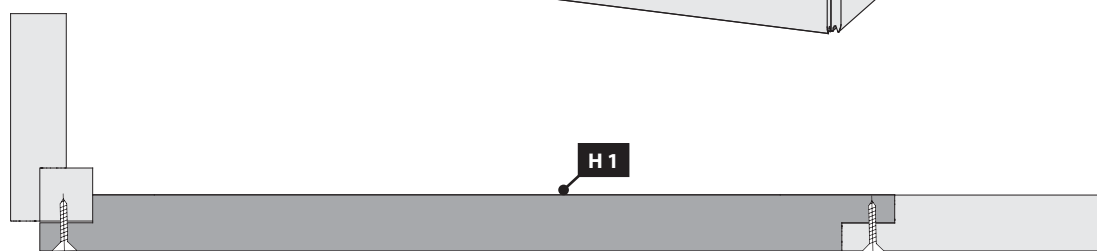
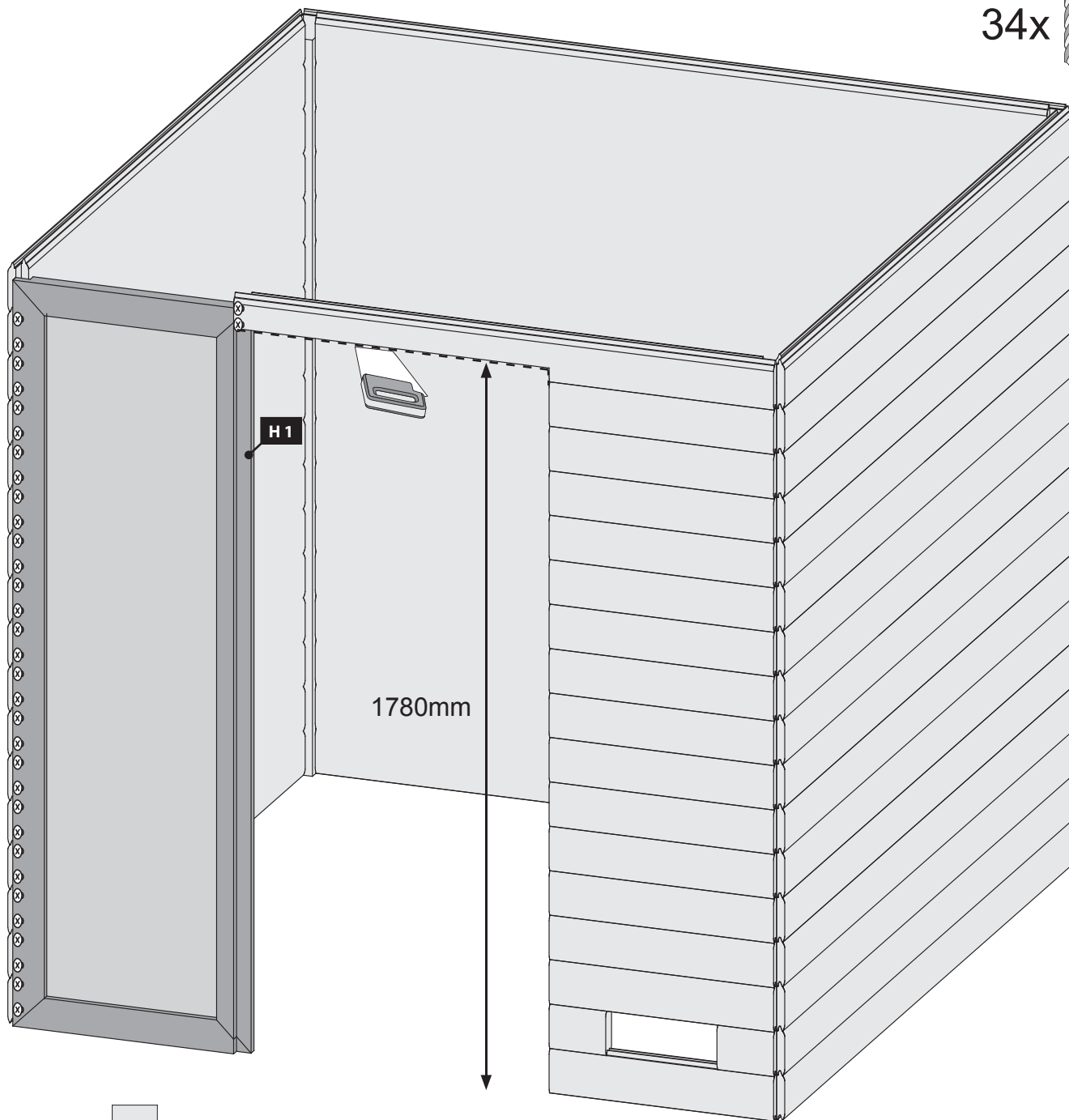
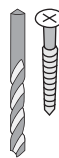

!!! A=B !!!
!!! C=D !!!

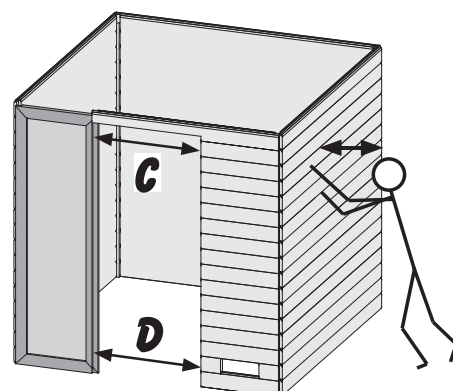

04

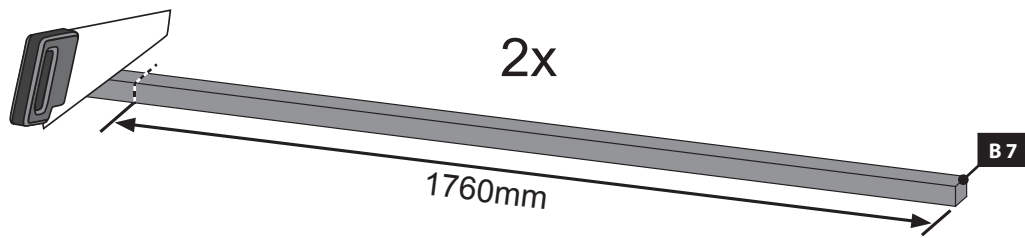

05

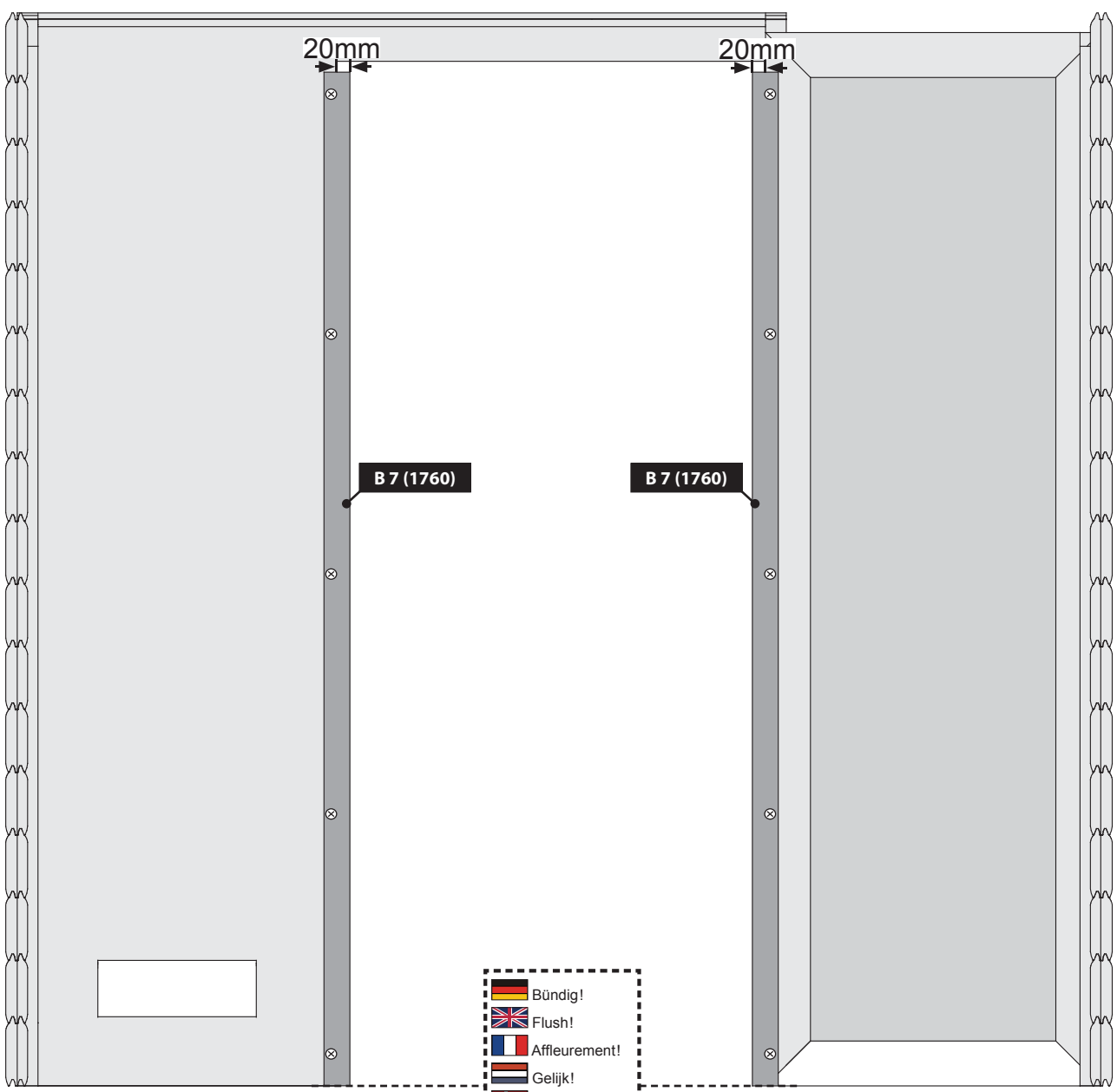
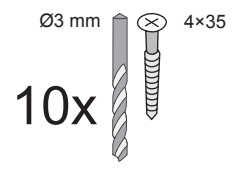



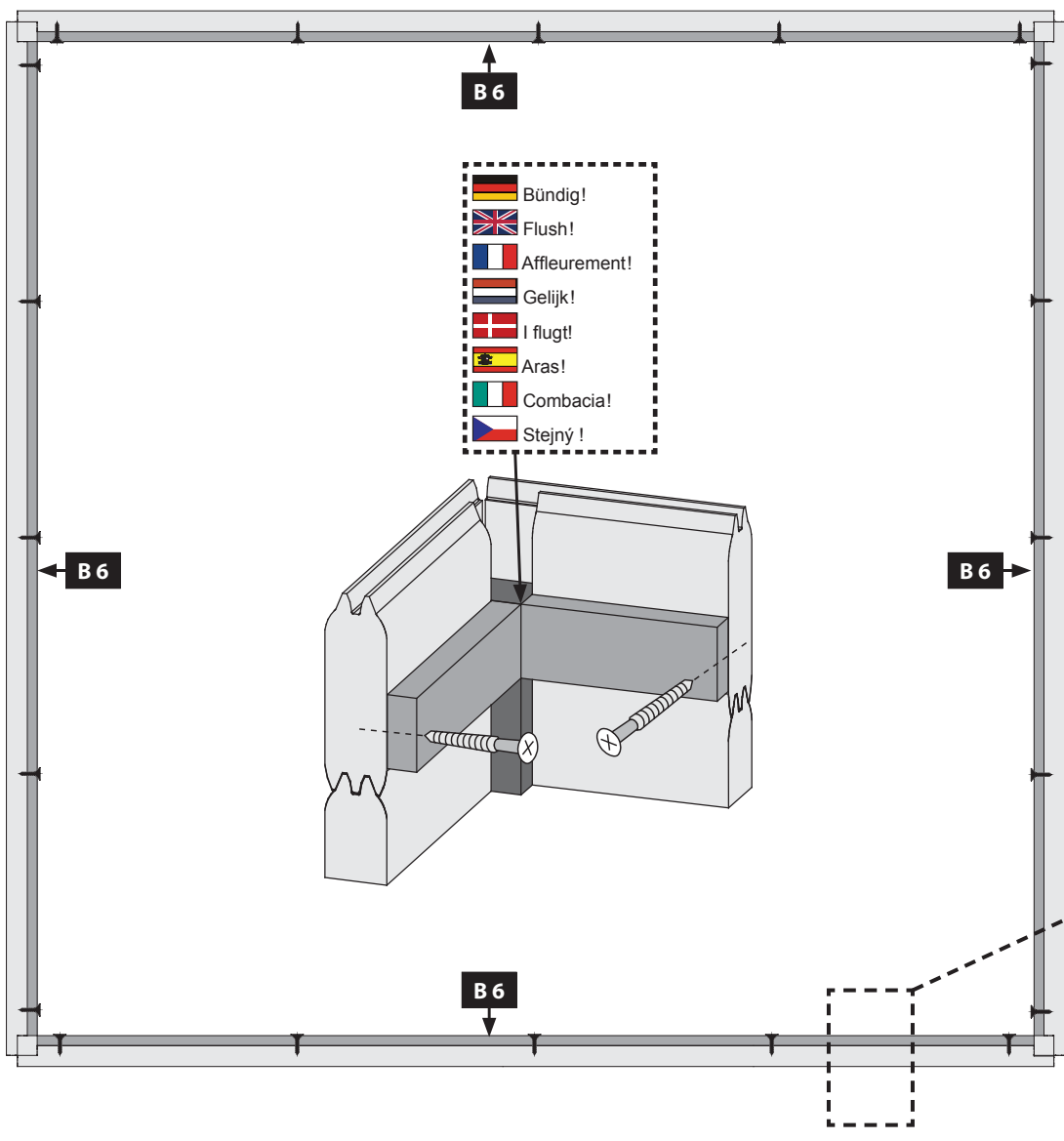

-  Bündig!
-  Flush!
-  Affleurement!
-  Gelijk!
-  I flugt!
-  Aras!
-  Combacia!
-  Stejný !

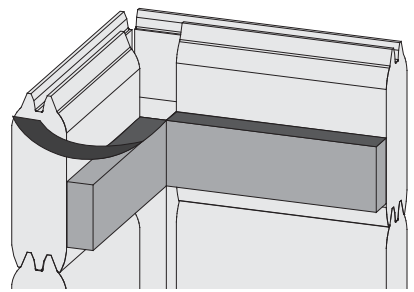
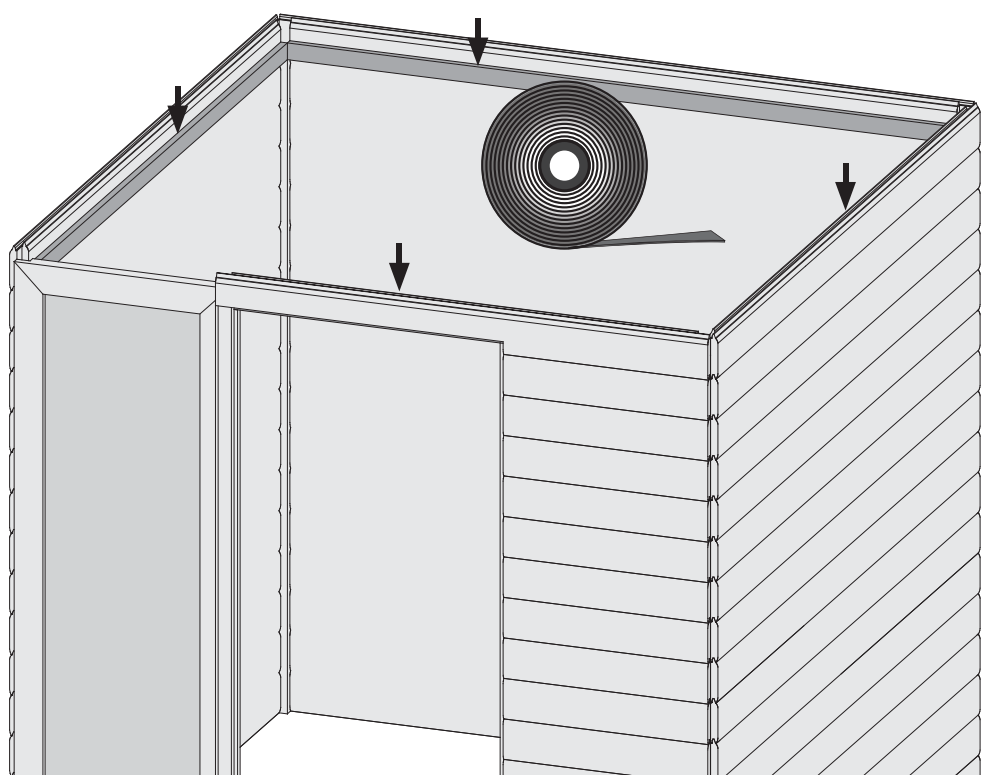
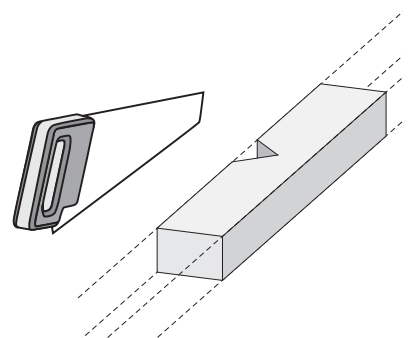





21x
Ø3 mm 4x40



- Sauna Dichtband
- Sauna sealing tape
- Ruban d'étanchéité pour sauna
- Sauna tætningsbånd
- Sauna afdichtingstape
- Cinta de sellado de sauna
- Nastro sigillante per sauna
- Sauna těsnící páska

-  Einbau Glastür
-  Installation of glass door
-  Montage porte en verre
-  Montage van de glazen deur

-  Installationsglasdør
-  Montaje de la puerta de cristal
-  Installazione portello di vetro
-  Sauna Instalace dveře

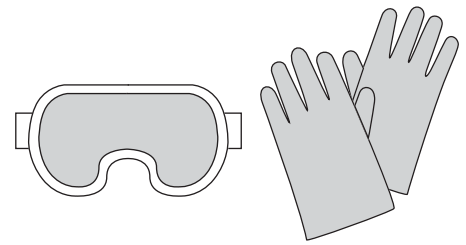

07



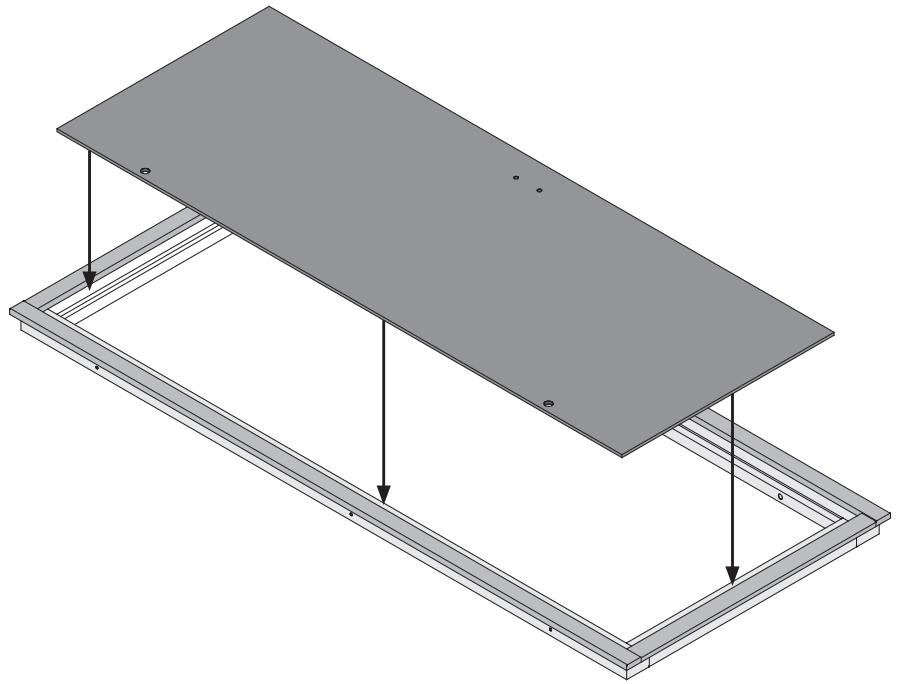

-  Saunätürglas in den Türrahmen legen
-  Put the door glass in the frame
-  Mettez le verre de la porte dans le cadre
-  Plaats het deurglas in het frame
-  Sæt dørglasset i rammen
-  Pon el vidrio de la puerta en el marco
-  Metti il vetro della porta nel telaio
-  Vložte sklo dveří do rámu



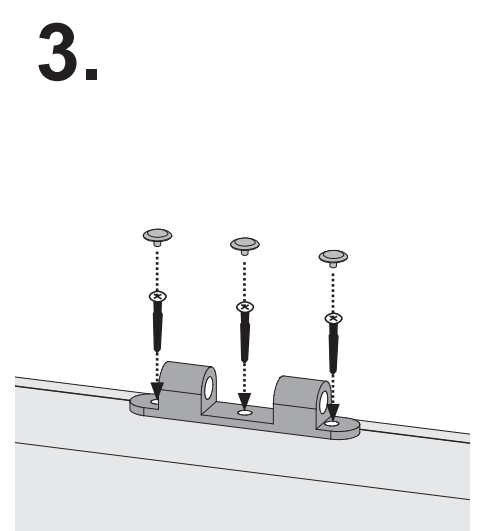
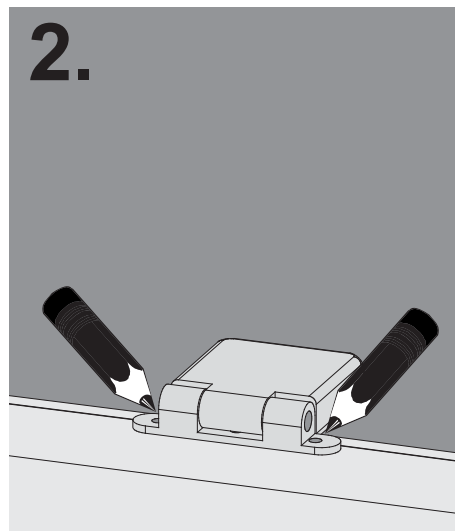
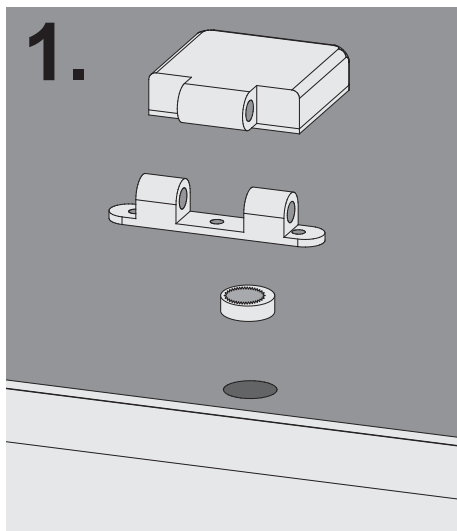
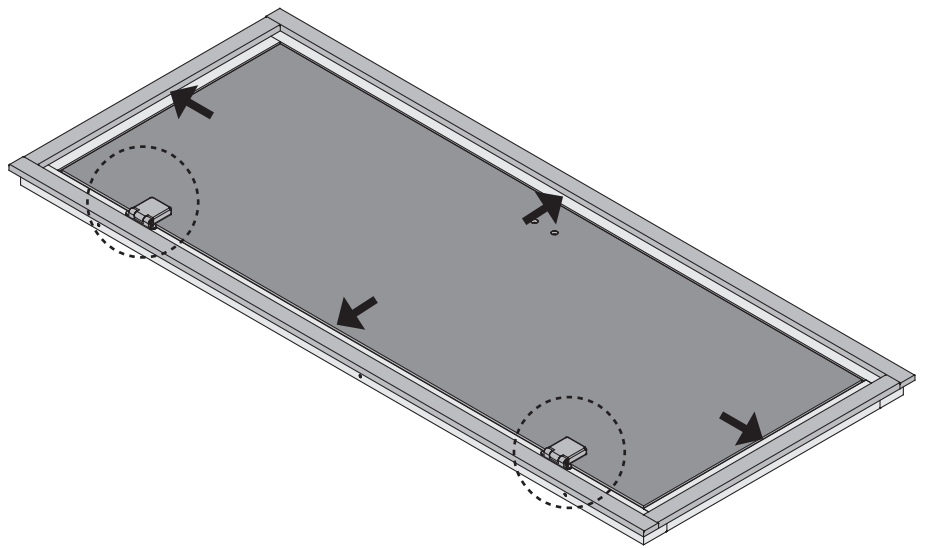



08

-  Saunätürglas in den Türrahmen ausrichten
-  Center the glass in the wooden frame
-  Bien aligner le verre à vitre
-  Lijn het glas uit in het deurframe
-  Juster saunaens dørglas i dørkarmen
-  Alinee el vidrio en el marco de la puerta
-  Allineare il vetro nel telaio della porta
-  Skleněná dvířka sauna v zárubně zarovnat



-  Einbau Glastür
-  Installation of glass door
-  Montage porte en verre
-  Montage van de glazen deur

-  Installationsglasdør
-  Montaje de la puerta de cristal
-  Installazione portello di vetro
-  Sauna Instalace dveře

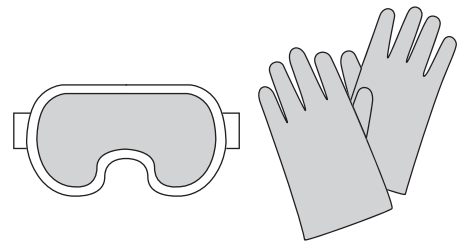

09



6x

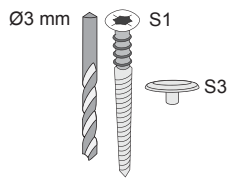

1.

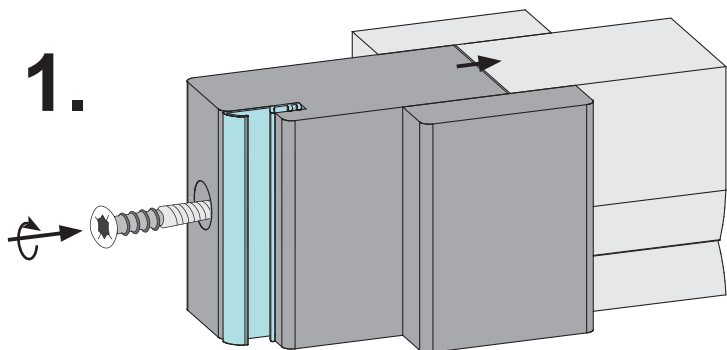

2.

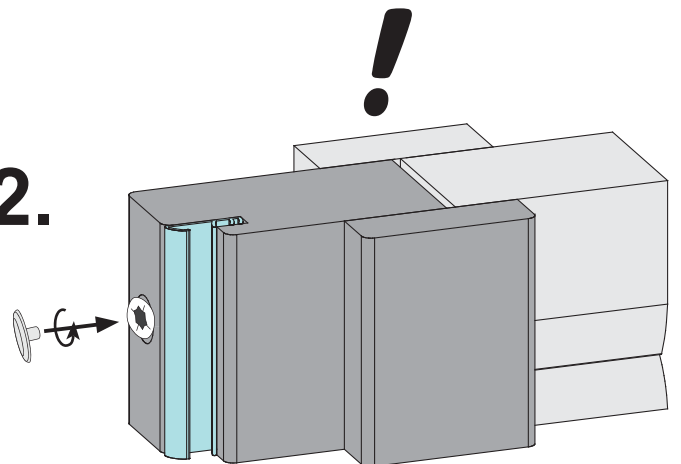

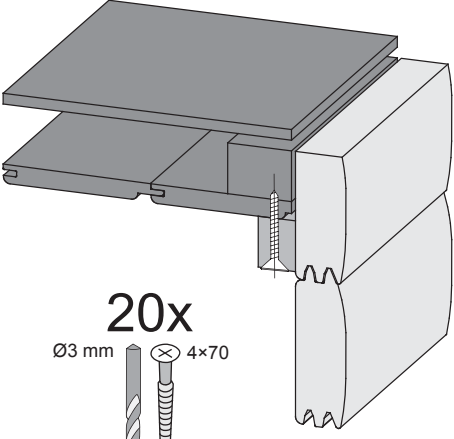
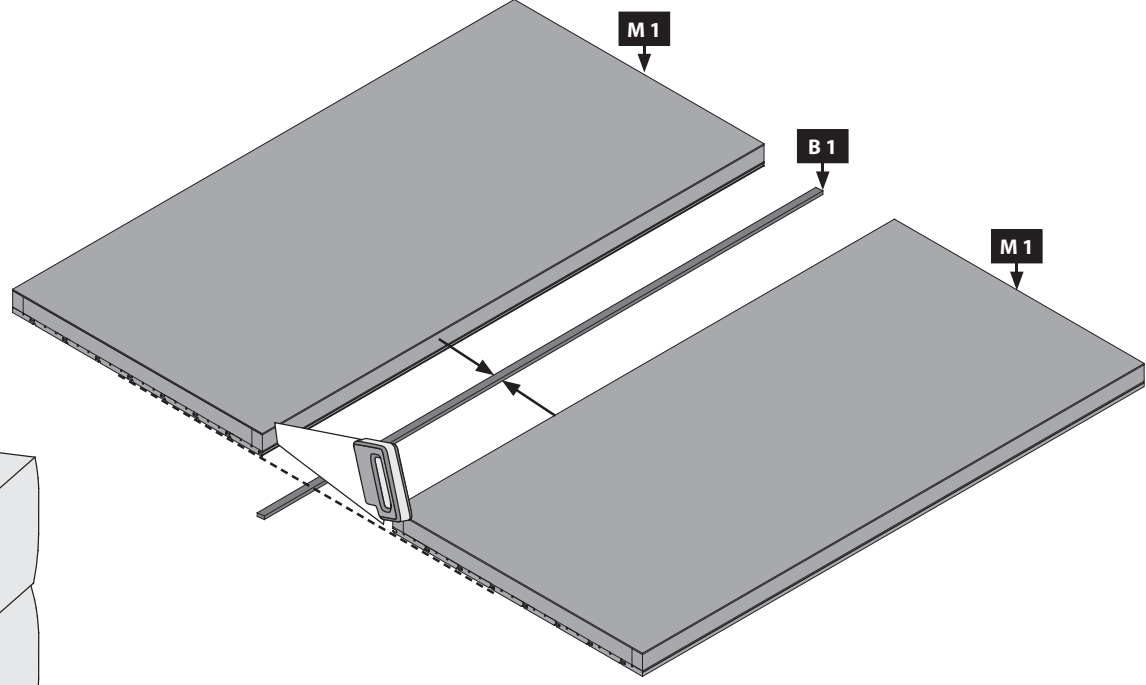

20x
 Ø3 mm 4x70

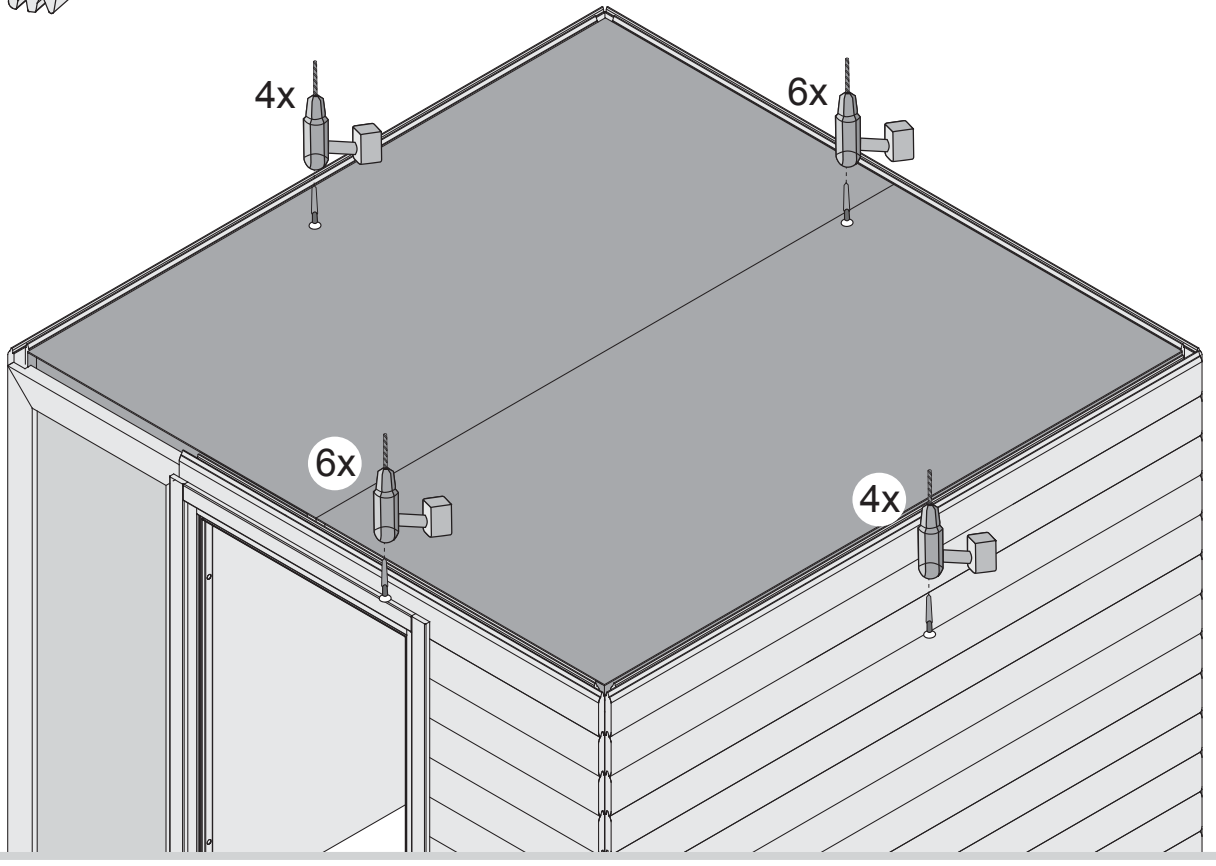

2x

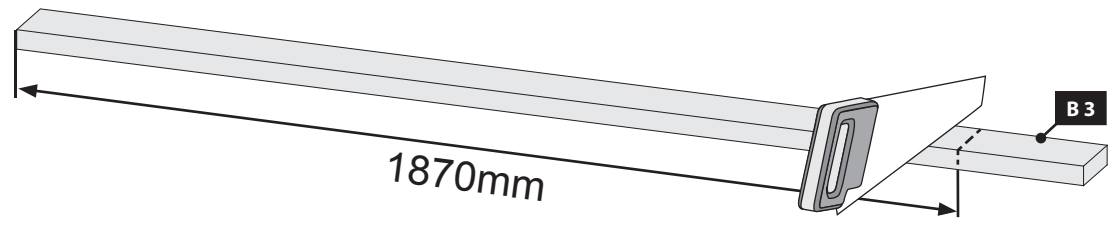

4x

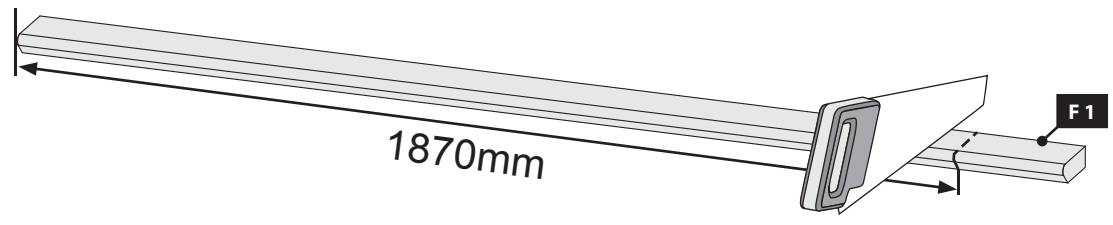

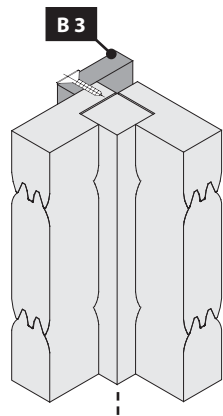

24x

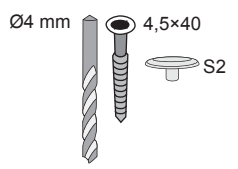

B 3 (1870)

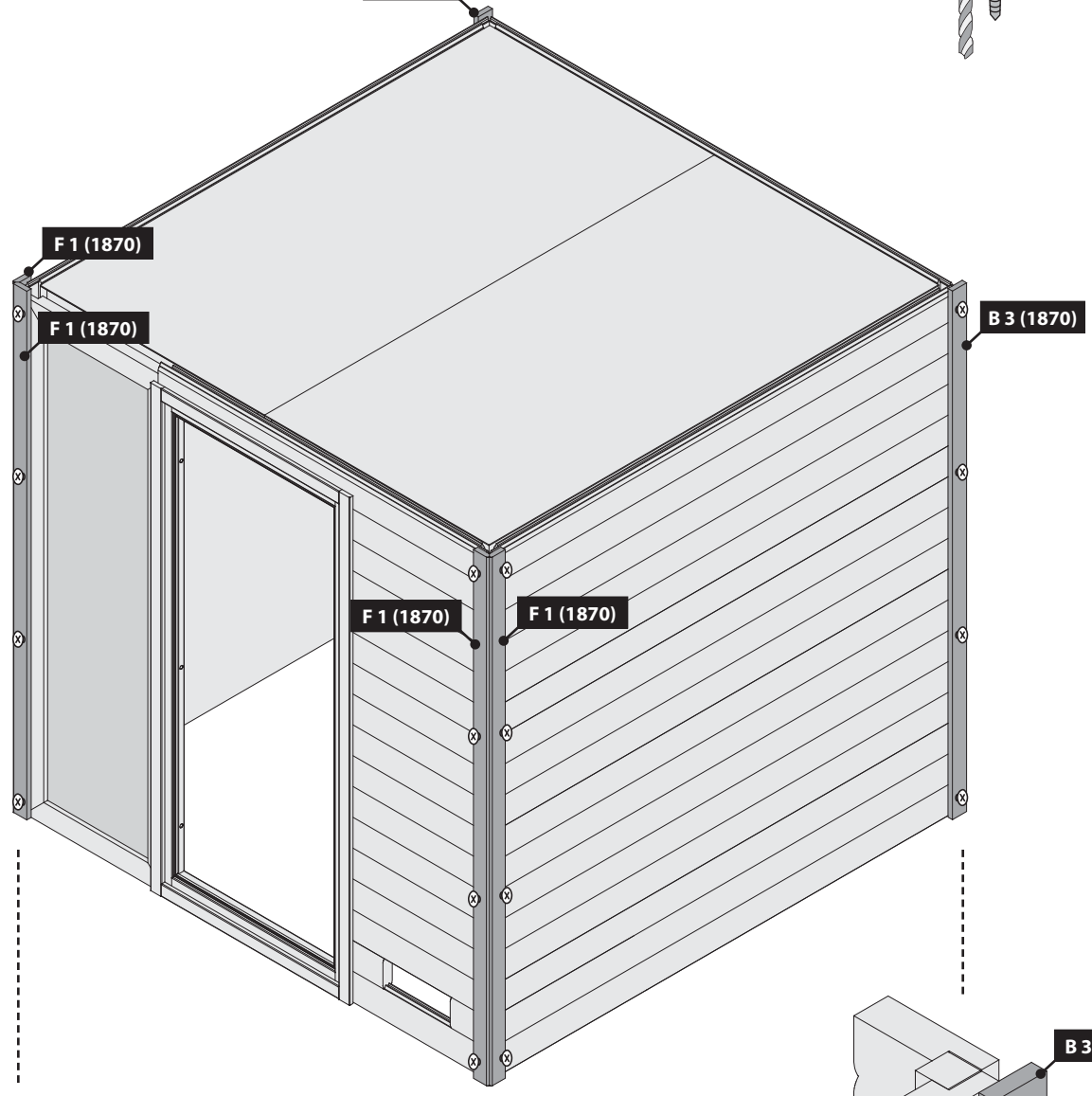

F 1 (1870)

F 1 (1870)

B 3 (1870)

F 1 (1870)

F 1 (1870)

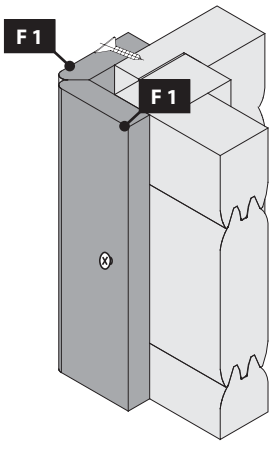

F 1

F 1

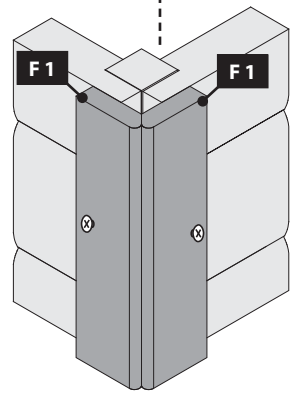

F 1

F 1

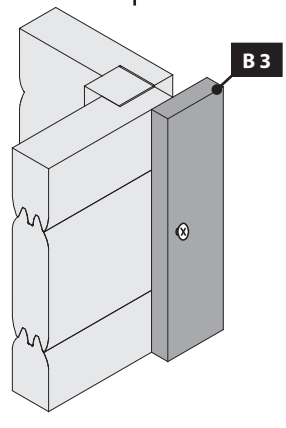

B 3

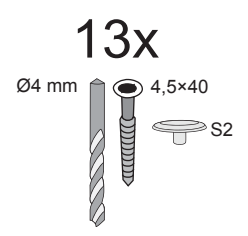
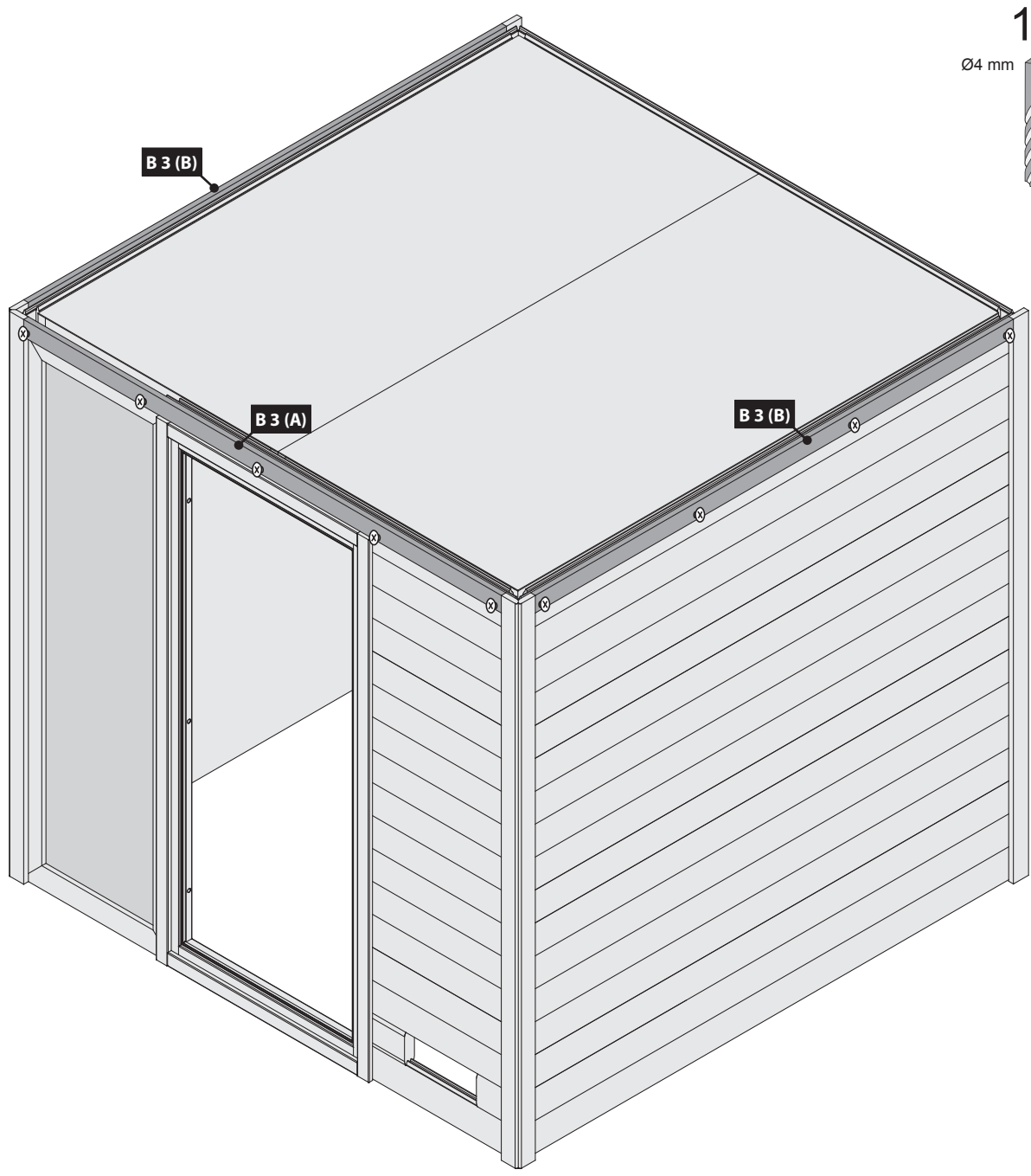
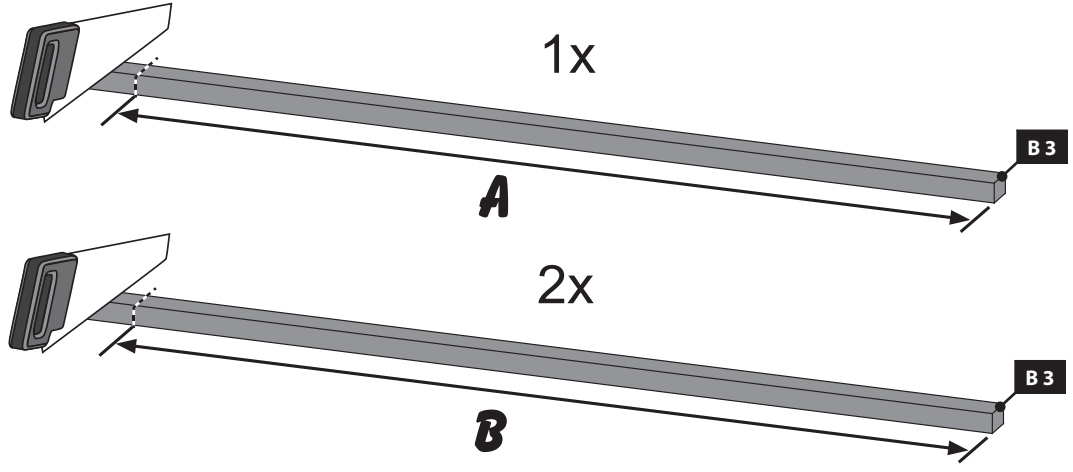

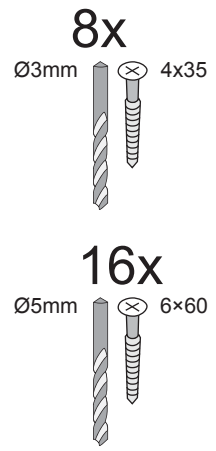

- Ansicht innen
- View Inside
- Voir à l'intérieur
- Bekijk binnen
- Ver dentro
- Visualizza dentro
- Zobrazit uvnitř
- Se inde

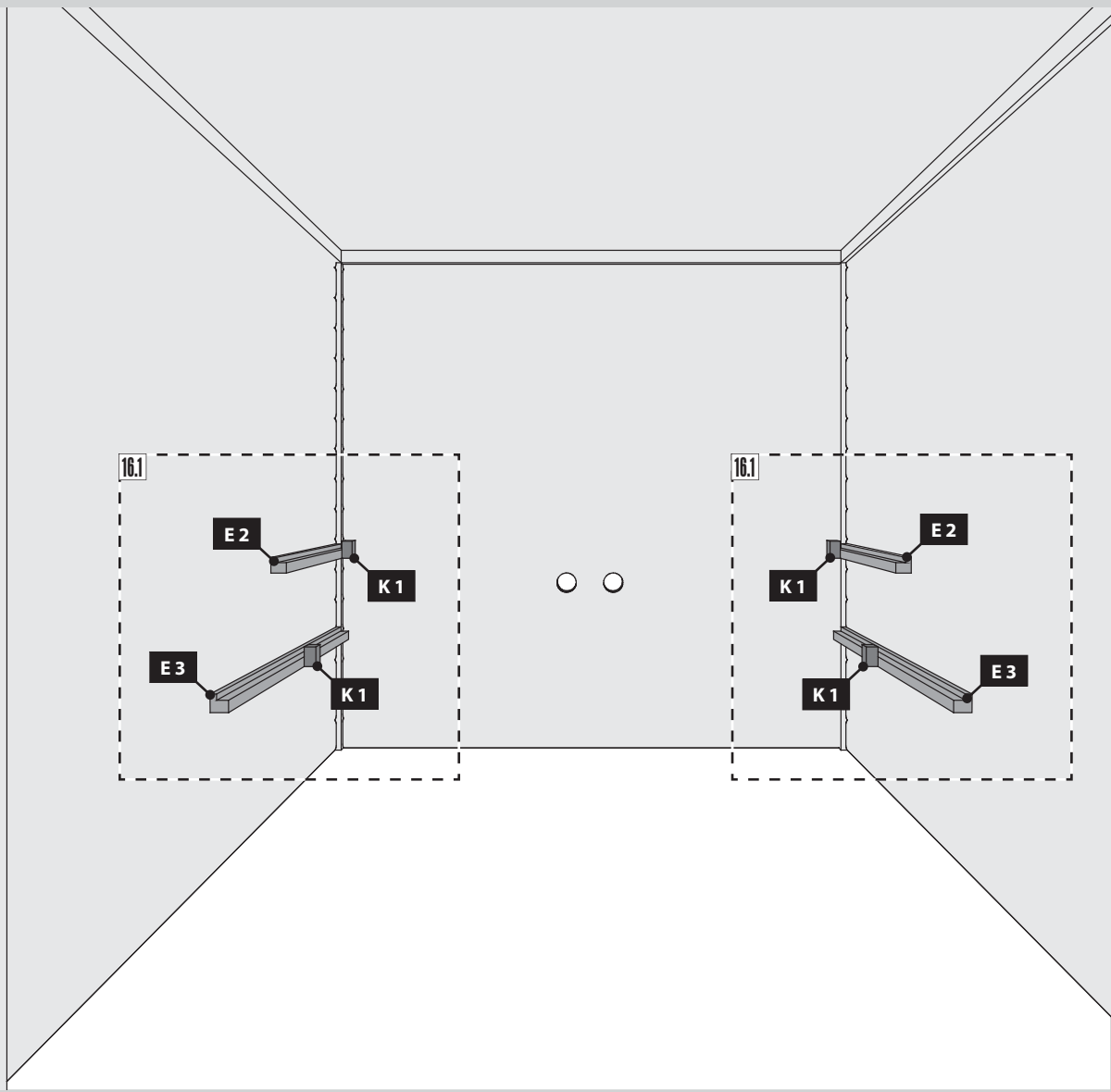



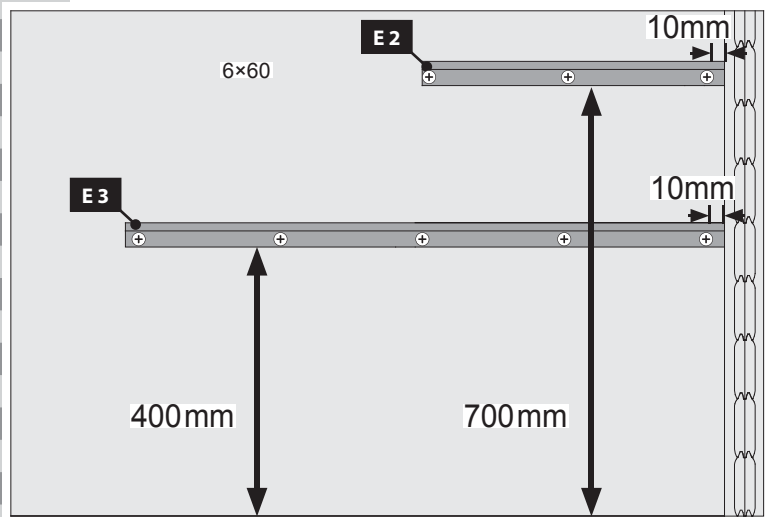



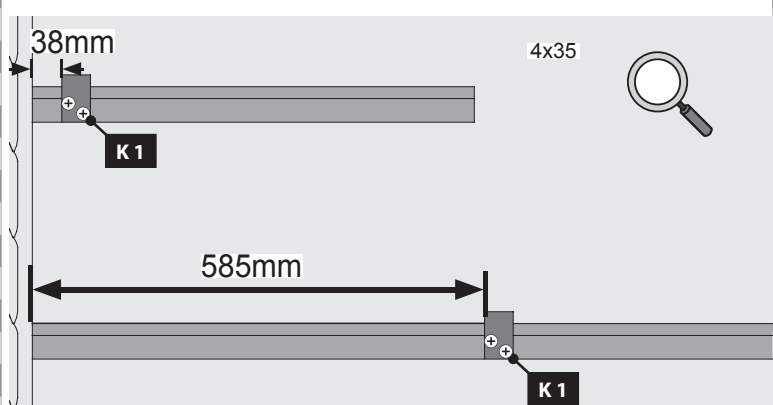
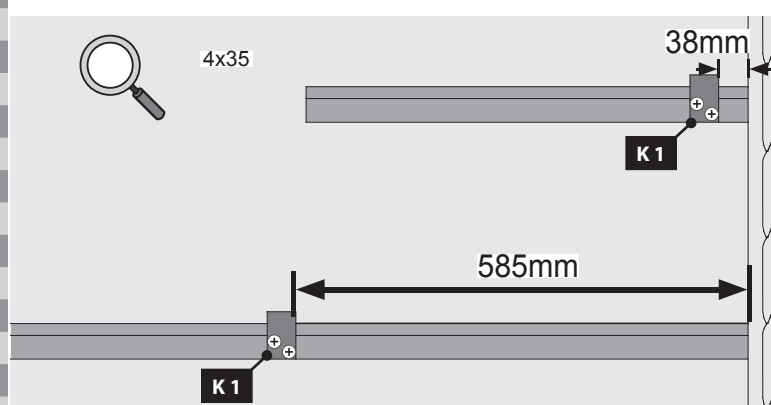
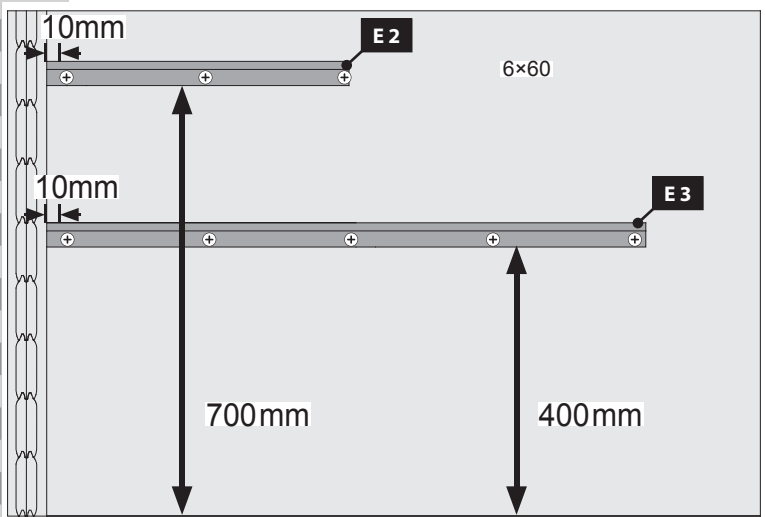

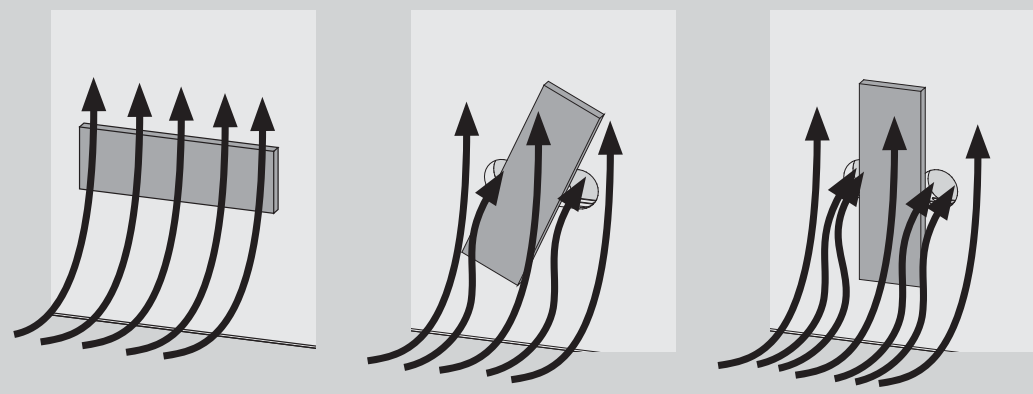
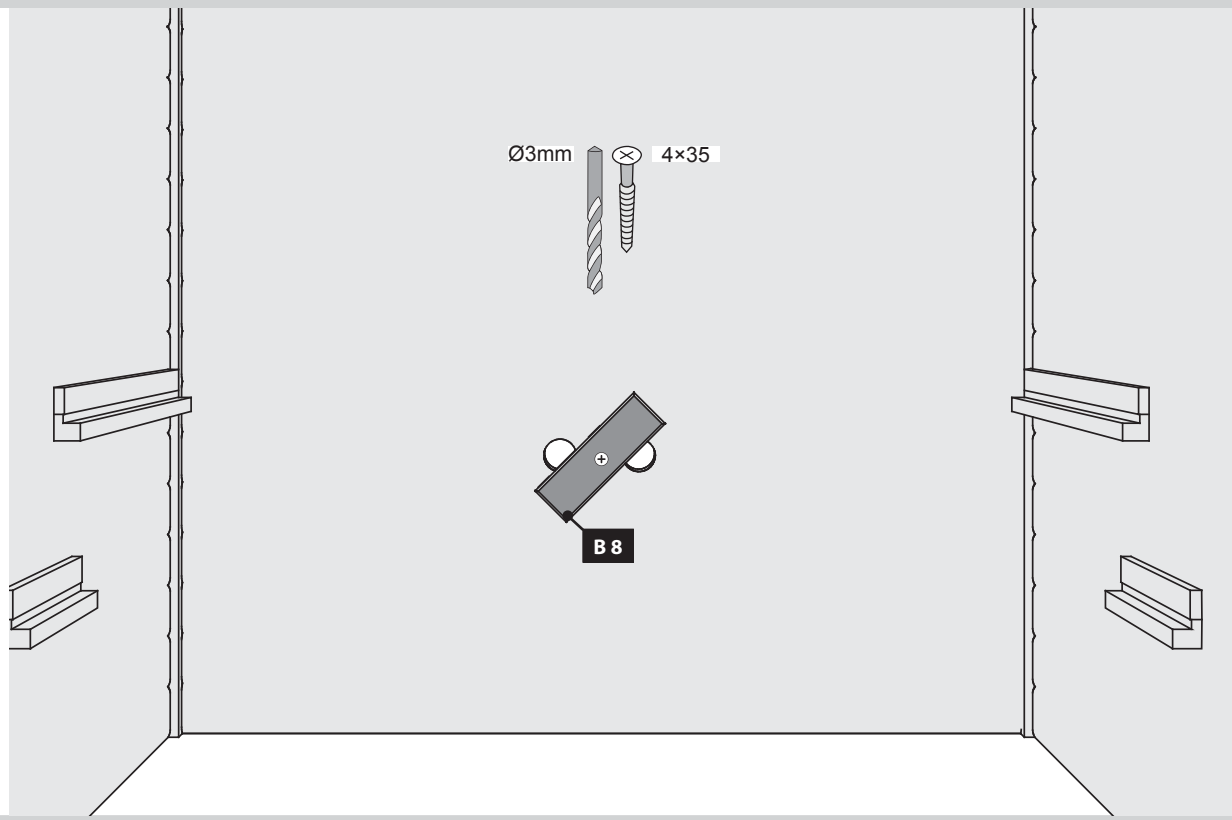
16.1



16.2





-  Hier ist die Funktionsweise des Brettes abgebildet. Regeln Sie damit die Abluft nach Ihren eigenen Wünschen.
-  Ceci représente le mode de fonctionnement de la planche. Avec elle, réglez l'écoulement de l'air selon vos désirs.
-  This figure shows the functional principle of the board. Regulate the exhaust air according to your own wishes.
-  Hier is de werking van het plankje afgebeeld. Regel daarmee de luchtafvoer naar eigen wens.
-  Aquí está representada la forma de funcionamiento de la tabla. Regule con ello el aire de salida según sus propios deseos.
-  Viene illustrato il principio di funzionamento della tavoletta di regolazione della ventilazione. Con essa si può regolare a piacere la ventilazione.
-  Zde je zobrazená funkce desky. Regulujte s ní odsávací vzduch dle Vašeho přání.
-  Sådant fungerer styret. Brug den til at regulere udstødningsluften efter dine egne ønsker.

2x

10x

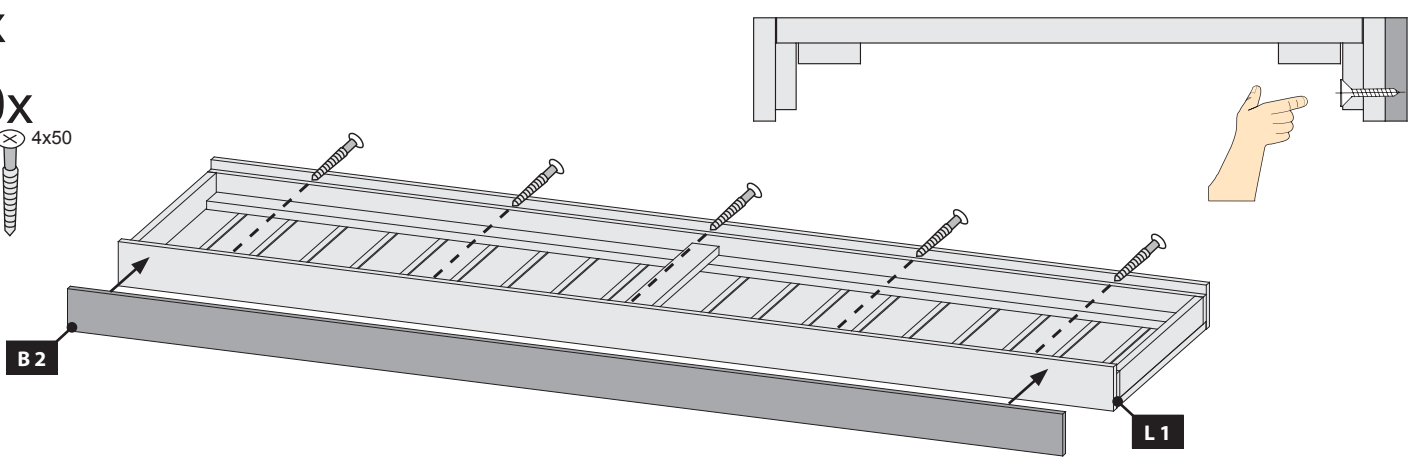
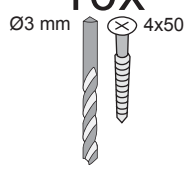

19

Ø3 mm 4x50

8x

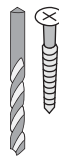

Ø3 mm 4x30

4x

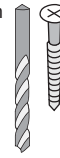

Ø3 mm 4x50

4x

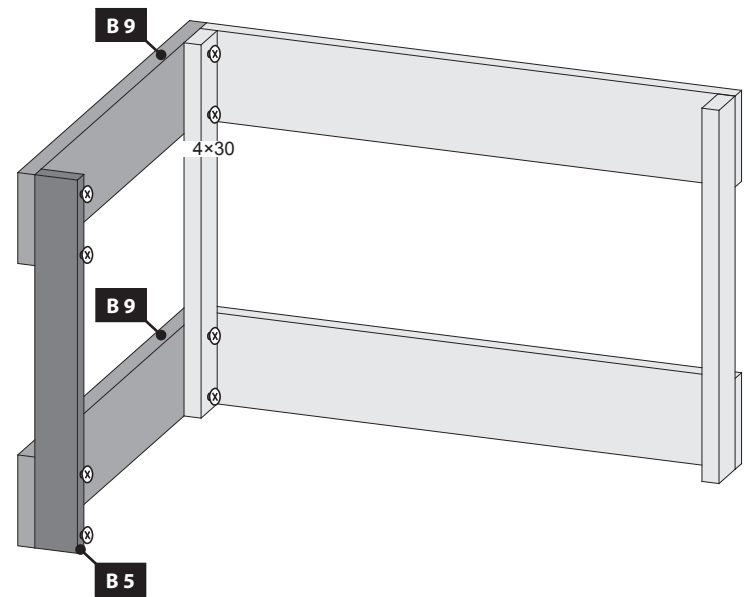
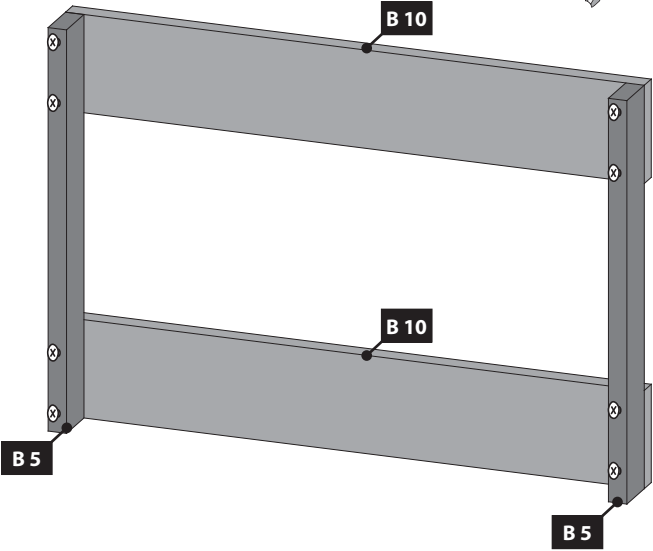
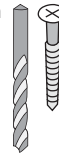

20

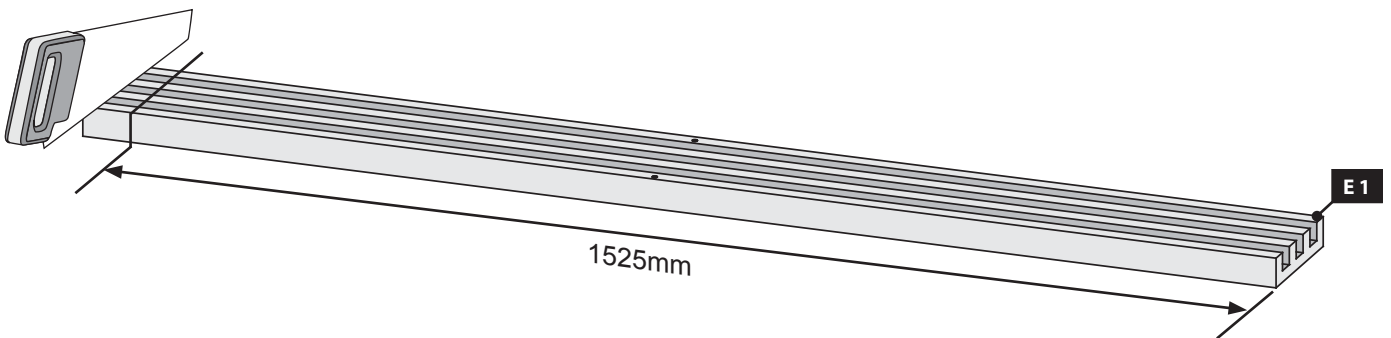

21

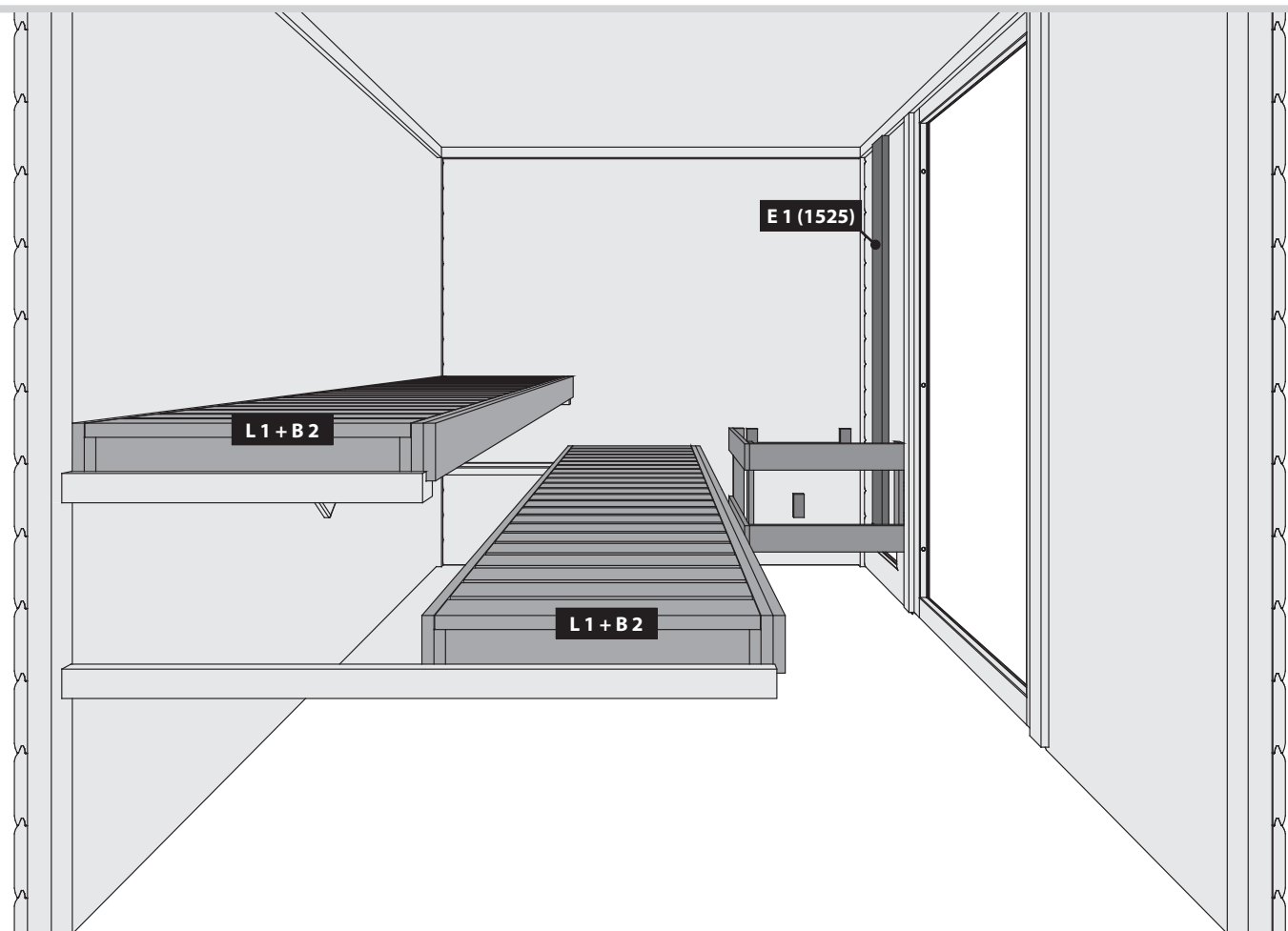

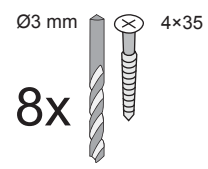
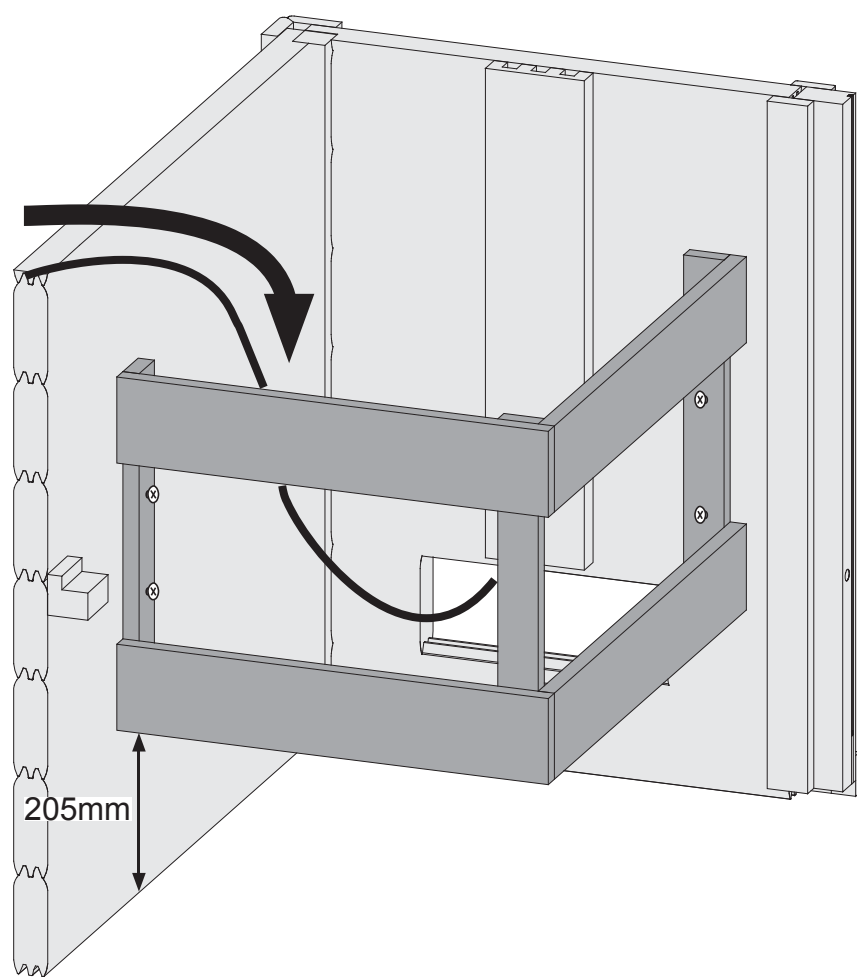
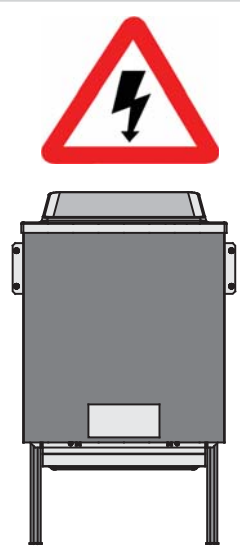
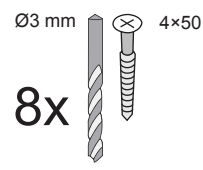
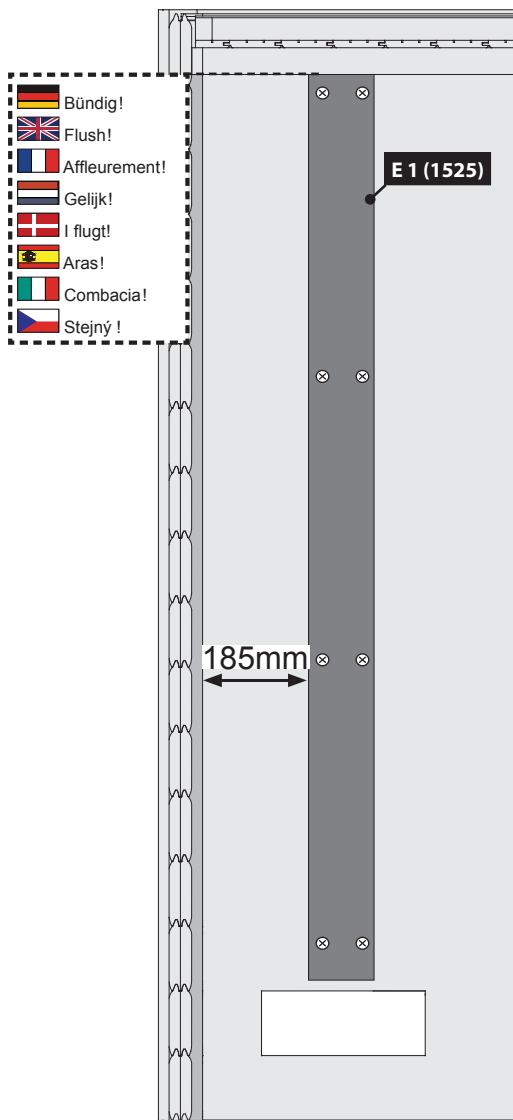



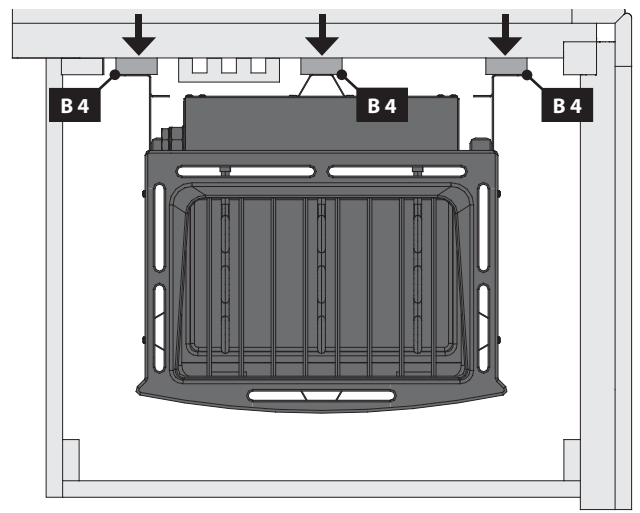
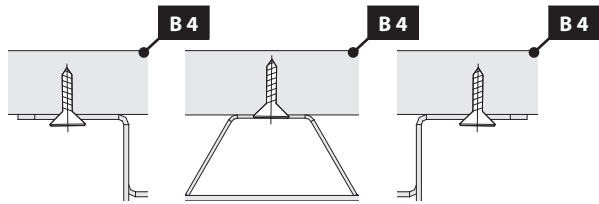

-  Ofenbefestigung
-  oven vaststelling
-  oven fixing
-  fixation four
-  fijación horno
-  fissaggio forno
-  upevňovací trouba
-  ovn fastsættelse



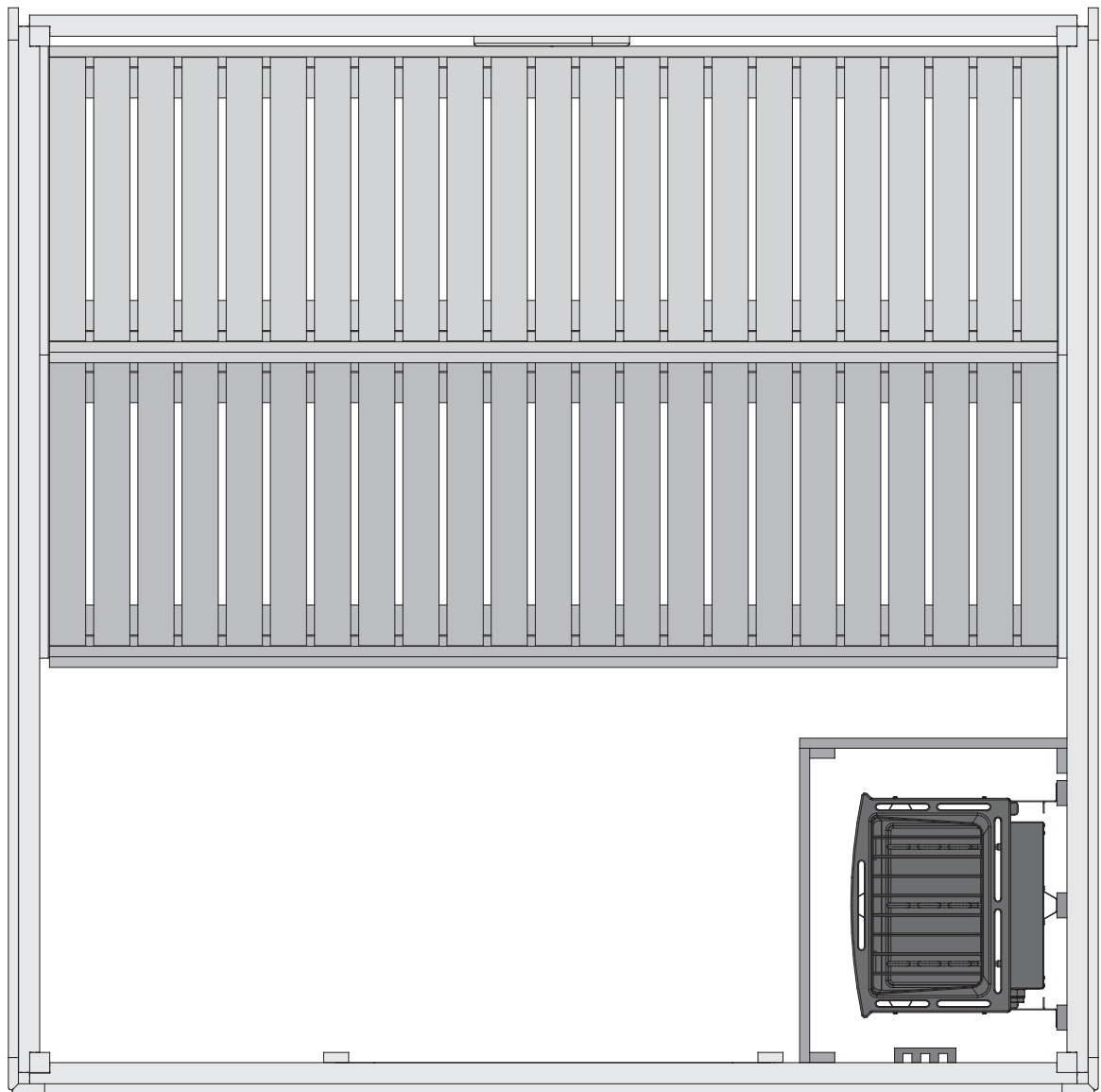
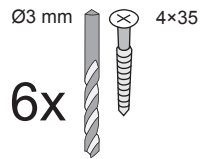



B 4

- | | |
|--|---|
|  Nur bei 9 kW-Ofen |  Sólo calentador de 9 kW |
|  Seulement 9 kW chauffe |  Solo riscaldamento 9 kW |
|  Only 9 kW heater |  Pouze topné těleso 9 kW |
|  Slechts 9 kW heater |  Kun ved 9 kW ovn |



-  Einbau Glastür
-  Installation of glass door
-  Montage porte en verre
-  Montage van de glazen deur

-  Installationsglasdør
-  Montaje de la puerta de cristal
-  Installazione portello di vetro
-  Sauna Instalace dveře

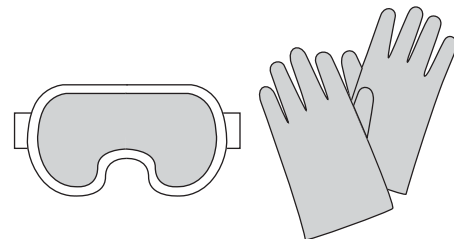

26

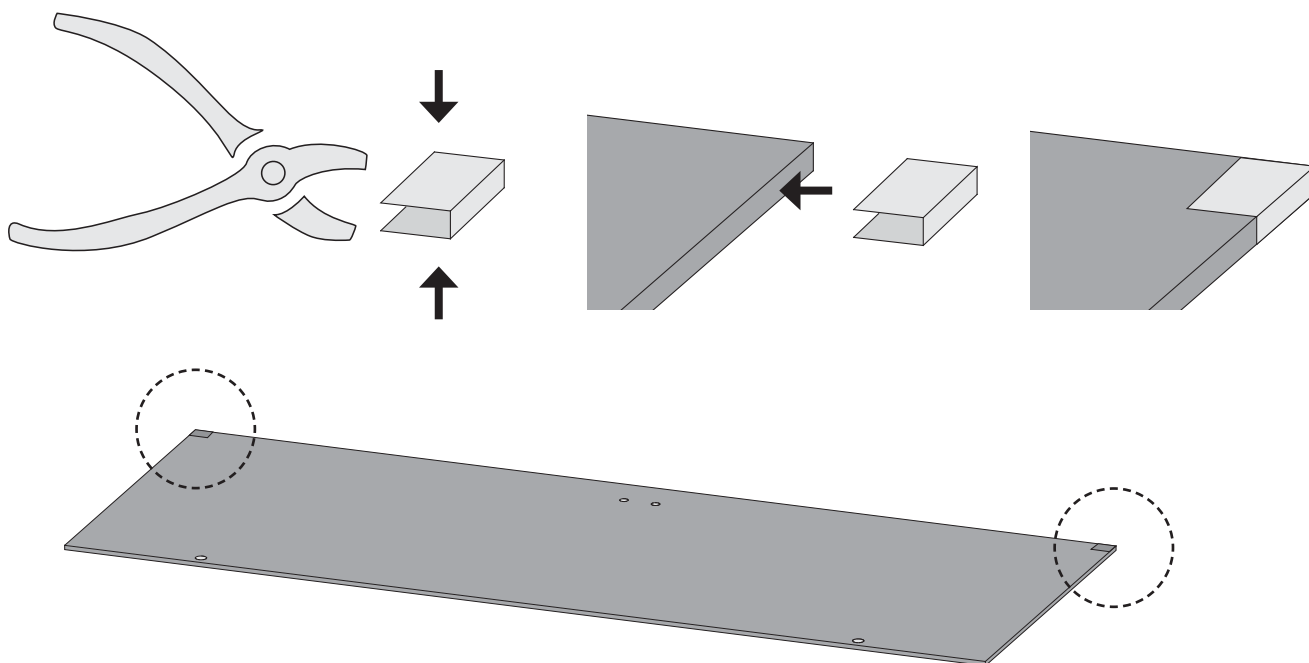



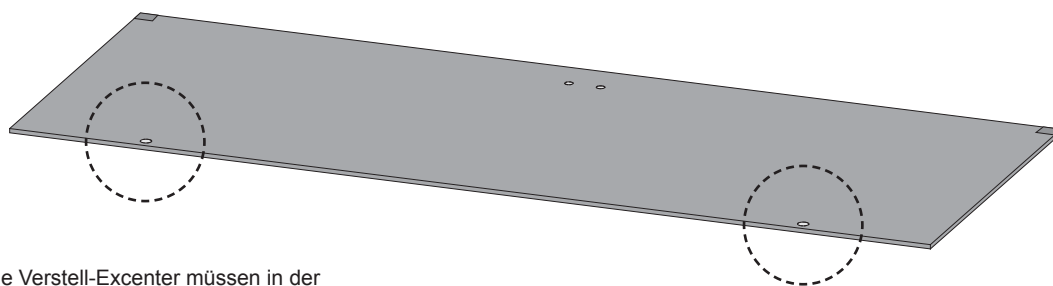



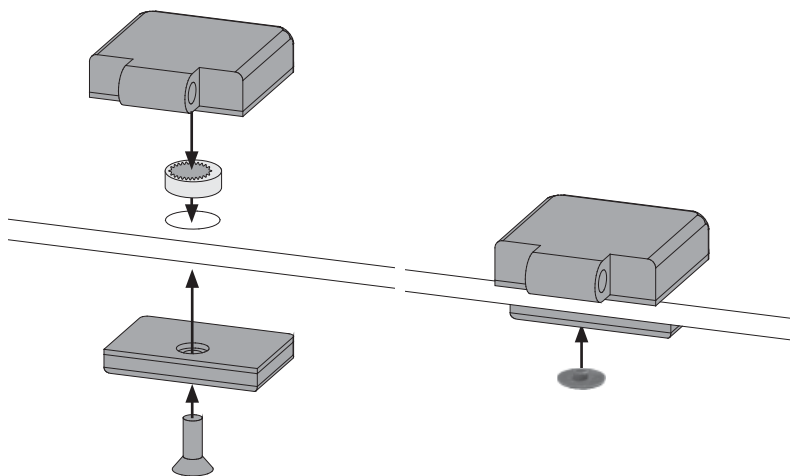

27







-  Alle Verstell-Excenter müssen in der Glasscheibe die gleiche Grundstellung haben
-  All adjustable eccentrics must have the same basic adjustment in the glass panel
-  Tous les excenteurs de positionnement doivent avoir la même position de base dans la vitre
-  Alle excentrische verstelelementen moeten in dezelfde stand in de glasplaat worden geplaatst
-  Alle justeringsexcenter skal have samme grundlæggende position i glasruden
-  Todos los excéntricos regulables tienen que tener la misma posición base en la hoja de cristal
-  Tutti gli eccentrici di regolazione devono avere la stessa posizione base nella lastra di vetro
-  šechny nastavovací podivínů musí mít stejný základní polohy ve skle



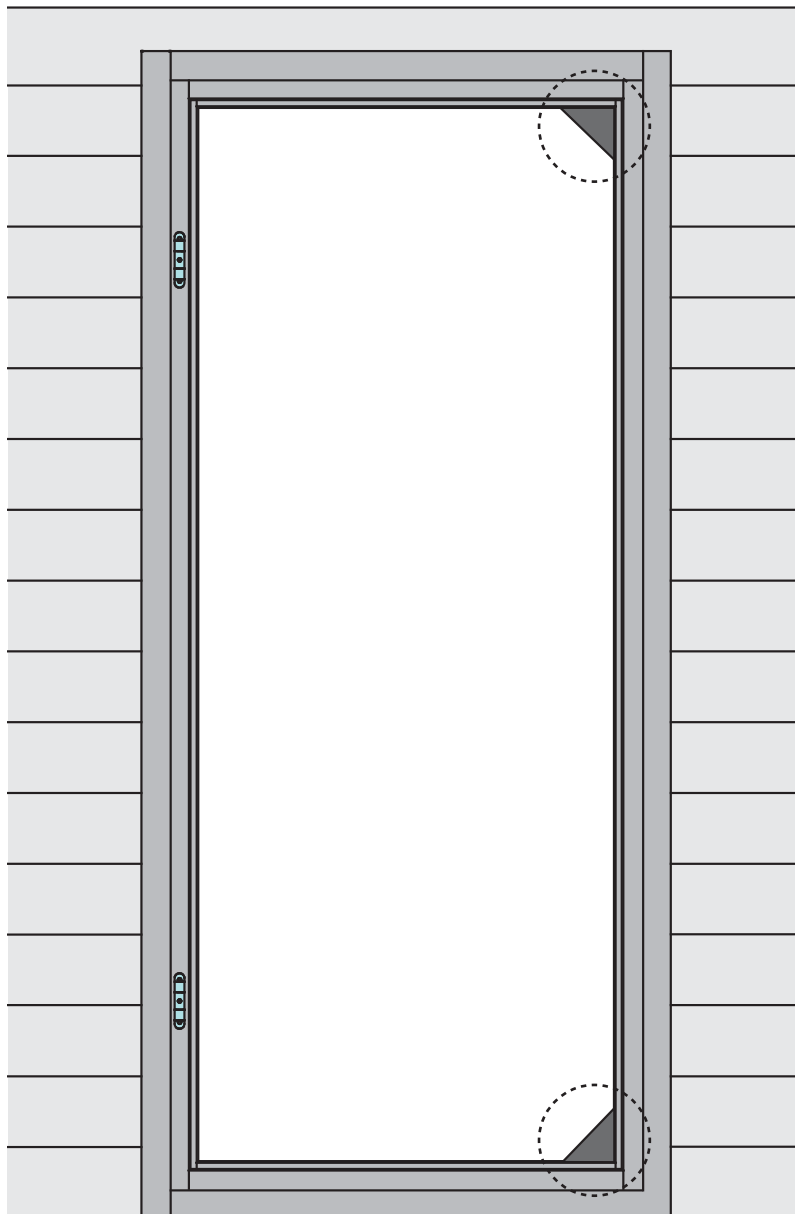
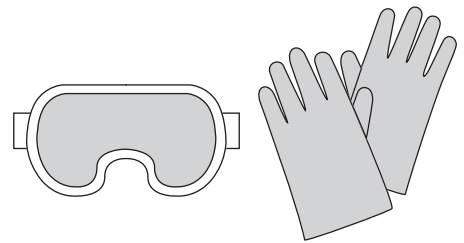



-  Einbau Glastür
-  Installation of glass door
-  Montage porte en verre
-  Montage van de glazen deur





-  Installationsglasdør
-  Montaje de la puerta de cristal
-  Installazione portello di vetro
-  Sauna Instalace dveře



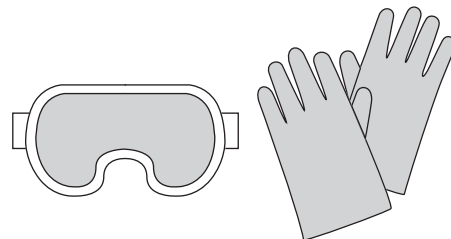



-  Einbau Glastür
-  Installation of glass door
-  Montage porte en verre
-  Montage van de glazen deur

-  Installationsglasdør
-  Montaje de la puerta de cristal
-  Installazione portello di vetro
-  Sauna Instalace dveře



-  Alle Verstell-Excenter müssen in der Glasscheibe die gleiche Grundstellung haben
-  All adjustable eccentrics must have the same basic adjustment in the glass panel
-  Tous les excentreurs de positionnement doivent avoir la même position de base dans la vitre
-  Alle excentrische verstelelementen moeten in dezelfde stand in de glasplaat worden geplaatst

-  Alle justeringsexcenter skal have samme grundlæggende position i glasruden
-  Todos los excéntricos regulables tienen que tener la misma posición base en la hoja de cristal
-  Tutti gli eccentrici di regolazione devono avere la stessa posizione base nella lastra di vetro
-  Šechny nastavovací podivínů musí mít stejný základní polohy ve skle

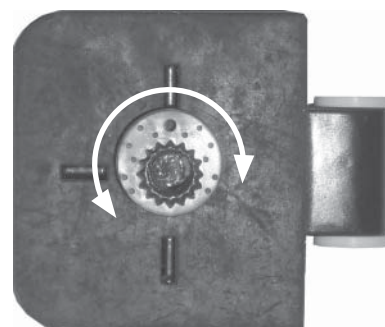
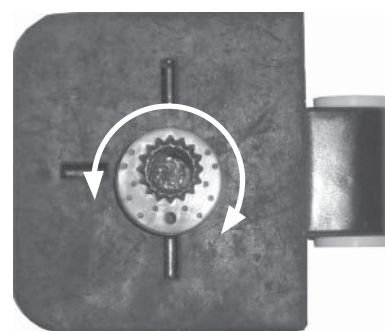
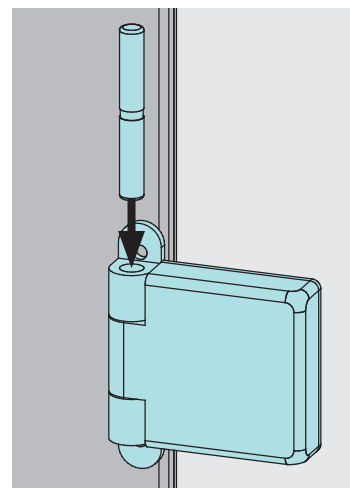
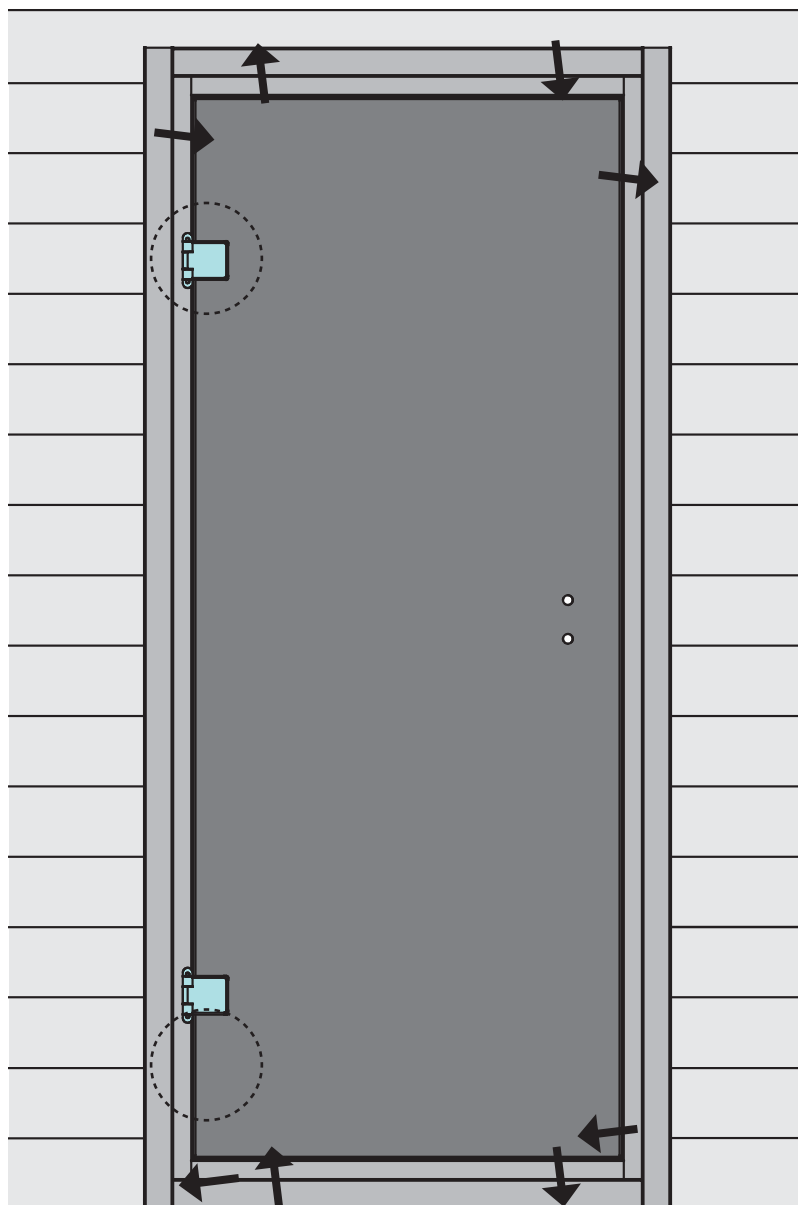

1.

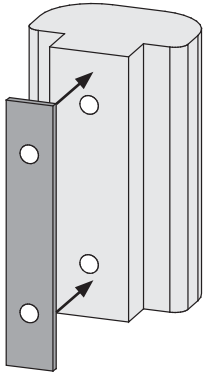

2.

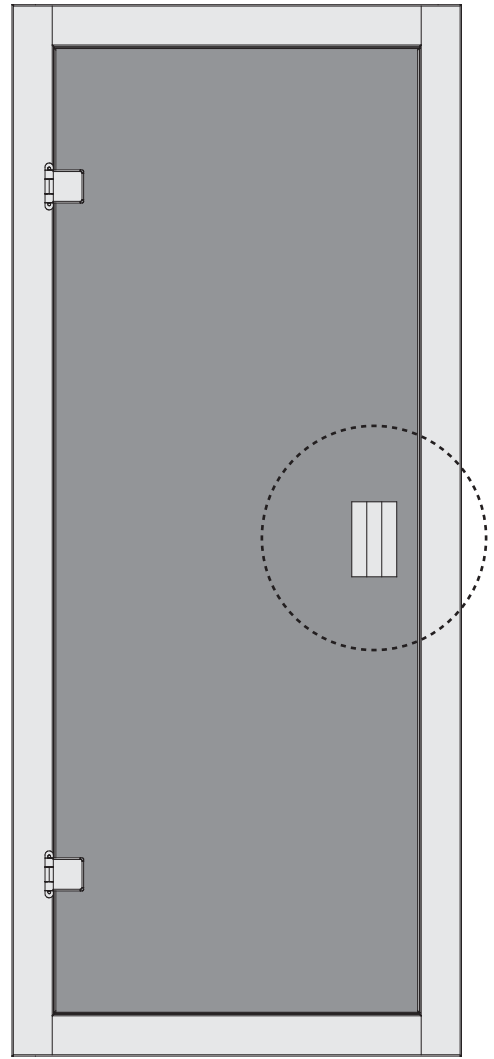
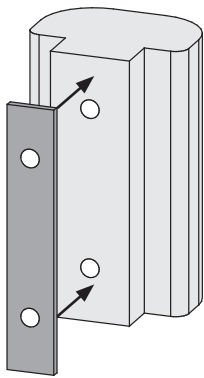

3.

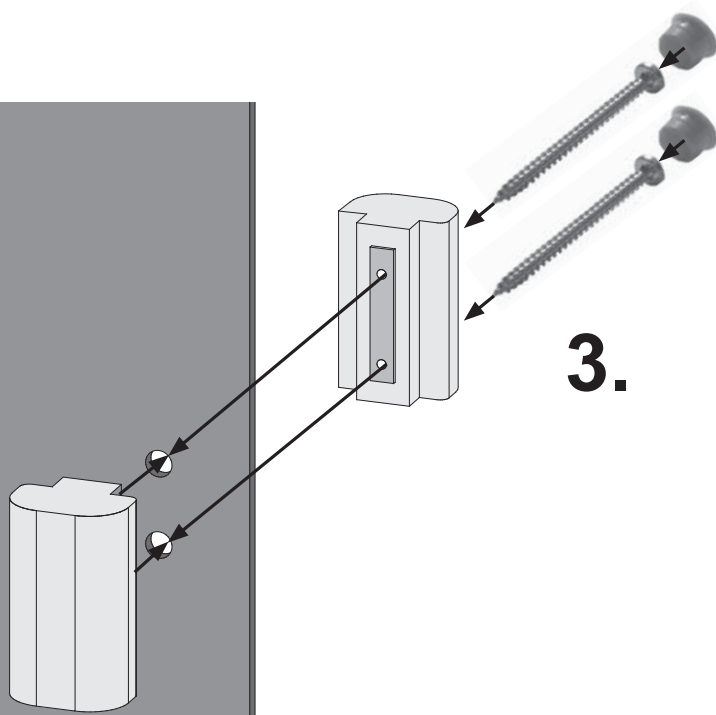

59855



Das komplette
Farbangebot
finden Sie auf:
[www.KARIBU-
FARBESHOP.de](http://www.KARIBU-FARBESHOP.de)

-  **Aufbauanleitung**
-  **Building Instructions**
-  **notice de montage**
-  **montagehandleiding**
-  **Montagevejledning**
-  **Instrucciones de construcción**
-  **Istruzioni per il montaggio**
-  **Montážní návod**

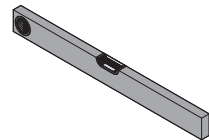
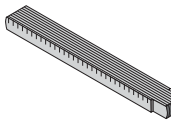
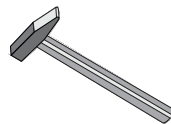
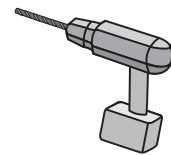
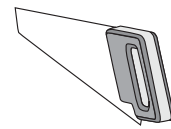

ID 53951

 Montage der Lampe

 Mounting the lamp

 Montaje de la lámpara

 Montage de la lampe

 Montage lamp

 Montaggio della lampada

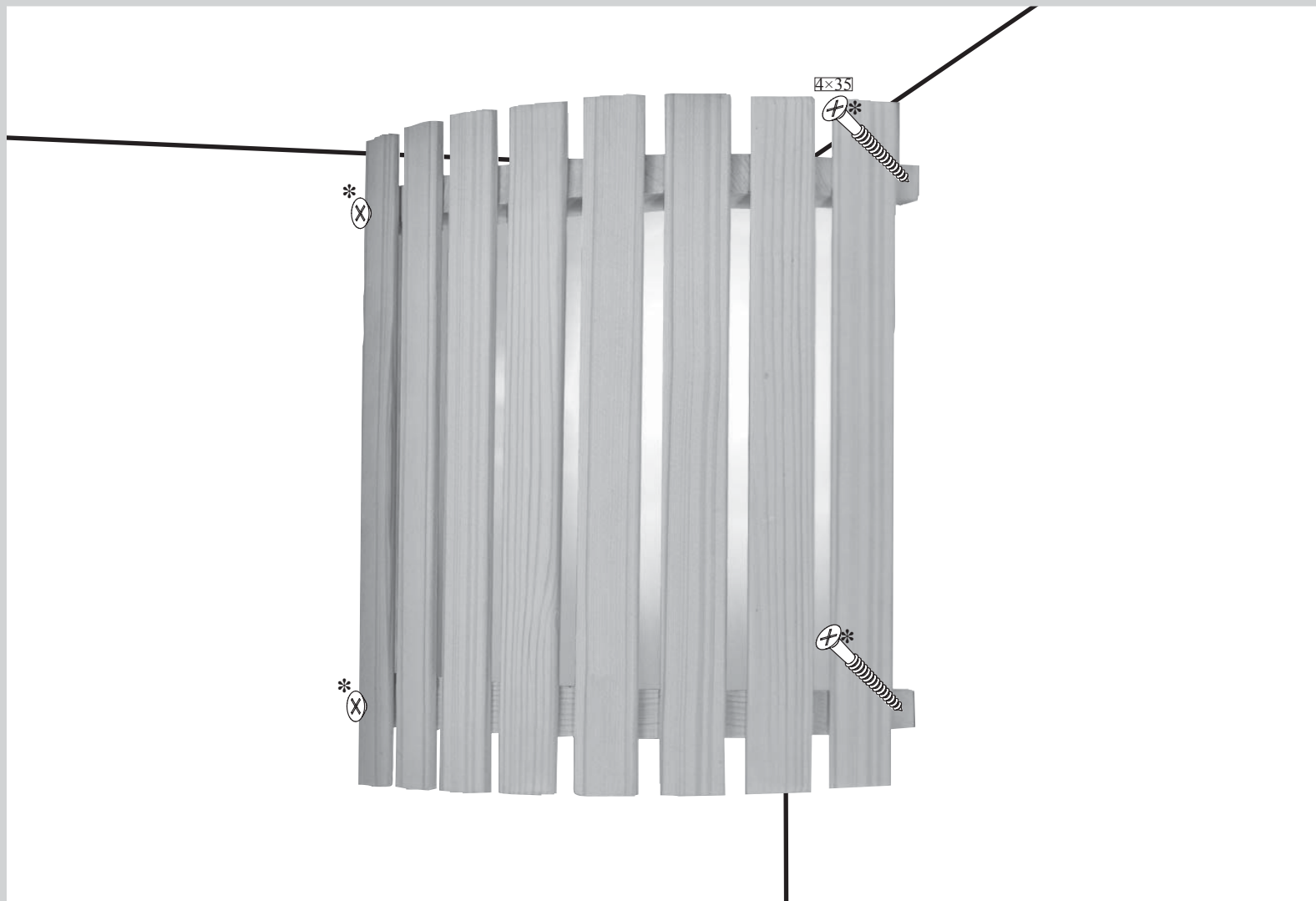

 ***Nicht im Lieferumfang enthalten!**

 ***Non comprises dans la livraison!**

 ***Not included!**

 ***Niet bijgeleverd!**

 ***No forman parte del suministro!**

 ***Non incluso!**

Saunaleuchte „Modern“ anbringen

Bild 1



Das Gehäuse von der Saunaleuchte vorbohren.

Bild 2



Das Gehäuse in einer Ecke positionieren.

Bild 3



Mit dem Akkubohrer, vier Schrauben befestigen.

Bild 4



Montageanleitung für Saunalampe

TECHNISCHE DATEN

230 V~, 50 Hz, max. 40W, E 27

EIGENSCHAFTEN UND ANWENDUNG

- Robustes und haltbares Aluminium-Druckguss-Gehäuse
- Schutzart IP 54

ANWENDUNG

Geeignet zur Verwendung in Saunen.

INSTALLATION

Wichtige Sicherheitshinweise:

- ! Die Installation darf ausschließlich durch eine Elektrofachkraft entsprechend den lokalen Anforderungen (z.B. VDE 0100) durchgeführt werden.
 - ! In Saunen nur geeignete Anschlussleitungen verwenden, welche für eine Temperatur von mind. 125° C geeignet sind..
 - ! Die Leuchte in Saunen nicht über dem Saunaofen montieren und einen Mindestabstand von 50 cm zu diesem einhalten (Fig. 2).
1. Befestigen Sie die Leuchte an der gewünschten Fläche in entsprechenden gebohrten Löchern mit den mitgelieferten Schrauben.
 2. Führen Sie die Anschlussleitung durch die Kabelzuführung des Leuchtengehäuses (Fig. 1)
 3. Führen Sie die Leiter durch die beiliegenden Schutzschläuche.
 4. Schließen Sie die Leiter an der Lampenfassung an, wobei das Leuchten-Gehäuse unbedingt mit dem Schutzleiter verbunden werden muss.
 5. Anschließend schrauben Sie eine Glühlampe mit max. 40 W Leistung in die Keramikfassung ein.
 6. Schrauben Sie das Schutzglas am Sockel der Leuchte fest.

LAMPENWECHSEL:

- ! Achtung Verbrennungsgefahr: Vor dem Wechseln des Leuchtmittels Lampe ausschalten und mind. 10 Minuten abkühlen lassen.
- ! Verwenden Sie ausschließlich Leuchtmittel gemäß Angabe auf dem Typenschild.
- ! Achtung Stromschlaggefahr: Vor Öffnen der Abdeckung unbedingt Lampe spannungsfrei schalten (durch Herausnehmen der Sicherung) und gegen Wiedereinschalten sichern.
- ! Zum Austausch des Leuchtmittels Abdeckung öffnen. Defektes Leuchtmittel herausschrauben und neues Leuchtmittel einschrauben. Anschließend Abdeckung/Schutzglas wieder verschrauben.

REINIGUNG / WARTUNG:

- ! Achtung Verbrennungsgefahr: Vor Reinigen Lampe mind. 10 Minuten abkühlen lassen.
- ! Achtung: Jede zerbrochene Scheibe ist umgehend durch eine neue Scheibe zu ersetzen.
- ! Glas/Gehäuse mit fusselfreiem Tuch abreiben. Keine Lösungsmittelhaltigen oder scheuernden Reinigungsmittel verwenden.

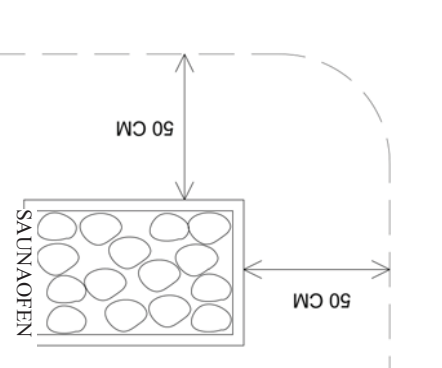
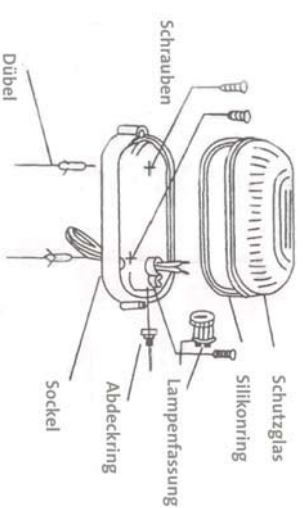

Fig. 1

Fig. 2



Návod k montáži saunového svítidla

TECHNICKÉ ÚDAJE

230 V~, 50 Hz, max. 40W, E 27

VLASTNOSTI A POUŽITÍ

- Robustní a trvanlivé těleso svítidla z tlakově litého hliníku
- Třída ochrany IP 54

POUŽITÍ

Vhodné pro použití v saunách.

INSTALACE

Důležité bezpečnostní pokyny:

- ! Instalace smí být provedena pouze kvalifikovaným elektrikářem v souladu s místně platnými předpisy (např. VDE 0100).
 - ! V saunách je nutné používat pouze odpovídající elektrické kabely, které jsou vhodné pro teplotu min. 125 °C.
 - ! Svítidlo nesmí být v sauně namontováno nad saunová kamna, vzdálenost od kamen musí činit min. 50 cm (obr. 1).
1. Svítidlo upevníte na zamýšlenou plochu do vhodné vyvrtaných otvorů pomocí příložených šroubů.
 2. Přívodní kabel provléknete otvorem v tělese svítidla (obr. 2).
 3. Elektrický kabel vedle uvrnit ochranných listů / hadic.
 4. Elektrický kabel připojíte k objímce žárovky, těleso svítidla musí být bezpodmínečně spojeno s ochranným vodičem.
 5. Poté do keramické objímky našroubujete žárovku o výkonu max. 40 W.
 6. Ochranné sklo pevně přišroubujete k základně svítidla.

VÝMĚNA ŽÁROVKY:

- ! **Pozor, nebezpečí popálení:** Svítidlo před výměnou žárovky zhasněte a nechte jej min. 10 minut vychladnout.
 - ! **Používejte pouze žárovky odpovídající údajům na typovém štítku.**
 - ! **Pozor, nebezpečí zásahu elektrickým proudem:** Před otevřením krytu svítidla jej bezpodmínečně odpojte od elektrické sítě (vyjmutím pojistek) a zajištěte jej proti připojení během práce.
- Při výměně žárovky nejprve otevřete kryt. Vyšroubujte deflektní žárovku a našroubujte novou. Poté opět přišroubujte kryt tvořený ochranným sklem.

ČIŠTĚNÍ / ÚDRŽBA:

- ! **Pozor, nebezpečí popálení:** Před čištěním nechte svítidlo min. 10 minut vychladnout.
 - ! **Pozor:** Rozbitá skleněná část musí být okamžitě nahrazena novou skleněnou částí.
- Skleněný kryt / těleso otírejte hadříkem, který nepouští chloupky. Nepoužívejte čistič prostředky na bázi rozpouštědel či abrazivních látek.

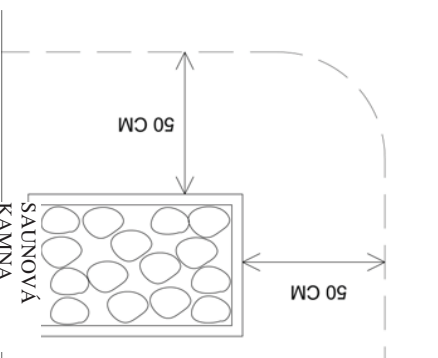

obr. 1

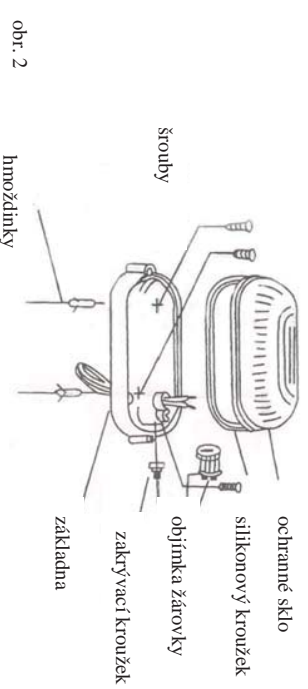

obr. 2

Instrucciones para el montaje de la luminaria de SAUNA

DATOS TÉCNICOS
230 V~, 50 Hz, máx. 40W, E 27

PROPIEDADES Y APLICACIÓN

- Robusta carcasa de fundición inyectada de aluminio
- Tipo de protección IP 45

APLICACIÓN

Apta para el uso en saunas.

INSTALACIÓN

Indicaciones de seguridad importantes:

- ! La instalación sólo puede ser realizada por un técnico electricista bajo cumplimiento de los requerimientos locales (p. ej. VDE 0100).
- ! En las saunas sólo está admitido utilizar cables de conexión apropiados para una temperatura de al menos 125 °C.
- ! Dentro de la sauna no está permitido instalar la luminaria por encima de la estufa, debiendo mantenerse una distancia mínima de 50 cm respecto a ella (fig. 1).

D	E
Schutzglas	Cristal protector
Silikonring	Anillo de silicona
Schrauben	Tornillos
Lampenfassung	Portalámparas
Abdeckring	Anillo cobertor
Socket	Base
Dübel	Taco

1. Fije la luminaria en el lugar deseado en orificios perforados para ello y con los tornillos adjuntos.
2. Pase el cable de conexión por el canal guía para cables de la carcasa de la luminaria (fig. 2).
3. Pase los conductores por los tubos protectores adjuntos.
4. Conecte los conductores al portalámparas, siendo obligatorio conectar la carcasa de la luminaria con el conductor de puesta a tierra.
5. A continuación coloque una bombilla, con una potencia máxima de 40 W, en el casquillo de cerámica.
6. Atornille el cristal protector a la base de la luminaria.

CAMBIO DE LA FUENTE DE LUZ

- ! Atención peligro de quemaduras: antes de cambiar la fuente de luz apague la lámpara y deje que se enfríe durante al menos 10 minutos.
 - ! Utilice únicamente fuentes de luz que se correspondan con los datos de la placa de características.
 - ! Atención peligro de descarga eléctrica: antes de abrir la tapa es imprescindible desconectar la tensión de la lámpara (extrayendo el fusible) y asegurarlo contra la conexión de nuevo.
- Para cambiar la fuente de luz hay que abrir la tapa. Desmontar la fuente de luz defectuosa y colocar una nueva. A continuación colocar de nuevo la tapa o el cristal protector.

LIMPIEZA Y MANTENIMIENTO

- ! Atención peligro de quemaduras: antes de limpiar la lámpara deje que se enfríe durante al menos 10 minutos.
 - ! Atención: los cristales rotos tienen que ser cambiados siempre de inmediato.
- Frotar el cristal y la carcasa con un paño que no deje pelo. No puede utilizarse productos abrasivos o que contengan disolventes.

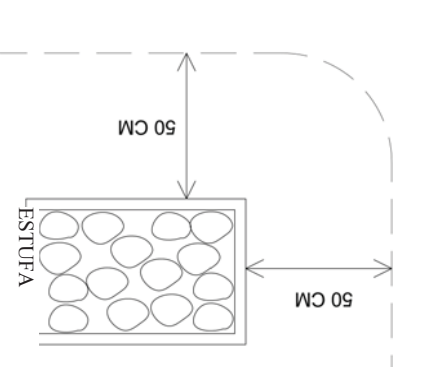

Fig. 1

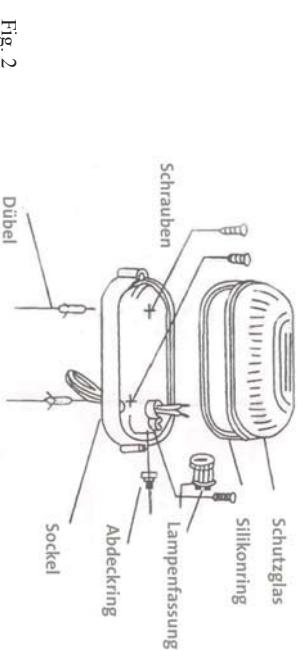

Fig. 2

Instructions de montage pour l'éclairage SAUNA

INFORMATIONS TECHNIQUES
230 V~, 50 Hz, max. 40W, E 27

CARACTÉRISTIQUES ET EMPLOI

- Boîtier solide et résistant en aluminium coulé sous pression
- Protection IP 54

EMPLOI

Destiné à une utilisation en sauna.

MONTAGE

Consignes importantes de sécurité :

- ! L'installation doit impérativement être exécutée par un électricien professionnel dans le respect des exigences locales (par ex. norme VDE 0100).
- ! Seuls des câbles de raccordement appropriés, adaptés à une température de 125 °C min. sont à utiliser dans les cabines de sauna.
- ! À l'intérieur du sauna, l'éclairage ne doit pas être monté au-dessus du poêle – veuillez respecter une distance minimale de 50 cm avec ce dernier (ill. 1).

1. Fixez l'éclairage sur la paroi souhaitée dans les trous percés à cet effet en utilisant les vis fournies.
2. Faites passer le câble de raccordement à travers l'entrée de câble présente sur le boîtier de l'éclairage (ill. 2).
3. Introduisez les conducteurs dans les gaines de protection livrées.
4. Raccordez les conducteurs à la douille de la lampe – le boîtier de l'éclairage doit impérativement être relié au conducteur de protection.
5. Pour terminer, vissez une lampe à incandescence d'une puissance max. de 40 W sur la douille en céramique.
6. Vissez le verre protecteur sur le socle de l'éclairage.

CHANGEMENT D'AMPOULE :

- ! Attention, risque de brûlure : avant de changer l'ampoule, veuillez éteindre la lampe et la laisser refroidir pendant au moins 10 minutes.
 - ! Veuillez utiliser uniquement des ampoules conformes aux indications présentes sur la plaque signalétique.
 - ! Attention, risque de décharge électrique : avant d'ouvrir le couvercle, veuillez impérativement mettre la lampe hors tension (en retirant le fusible) et prendre les mesures nécessaires pour empêcher toute tension accidentelle.
- Pour changer l'ampoule, veuillez ouvrir le couvercle. Dévissez l'ampoule défectueuse et vissez-en une neuve. Revissez le couvercle/le verre protecteur.

NETTOYAGE/MANTENANCE :

- ! Attention, risque de brûlure : avant de nettoyer la lampe, veuillez la laisser refroidir pendant au moins 10 minutes.
 - ! Attention : un verre fendu ou brisé doit immédiatement être remplacé par un verre neuf.
- Nettoyez le verre/le boîtier avec un chiffon non pelucheux. Veuillez ne pas utiliser de produits nettoyants à teneur en solvant ou abrasifs.

D	F
Schutzglas	Verre protecteur
Silikonring	Anneau de silicone
Schrauben	Vis
Lampenfassung	Douille
Abdeckring	Anneau de recouvrement
Socket	Socle
Dübel	Goujon

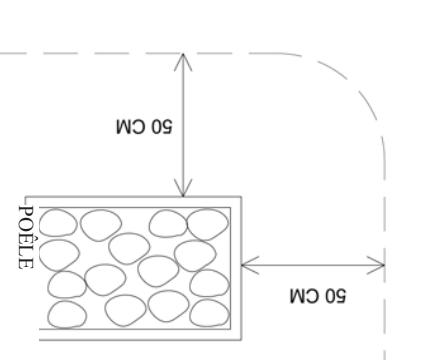

ill. 1

ill. 2

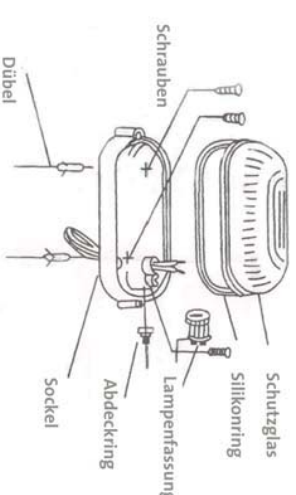

Istruzioni di montaggio lampada per SAUNA

DATI TECNICI

230 V~, 50 Hz, max. 40W, E 27

CARATTERISTICHE ED IMPIEGO

- Corpo in alluminio pressofuso robusto e resistente
- Tipo di protezione IP 54

IMPIEGO

Adatta per l'utilizzo in saune.

INSTALLAZIONE

Importanti avvertenze sulla sicurezza:

- ! L'installazione deve essere eseguita esclusivamente da un elettrotecnico in conformità con le normative locali (es. VDE 0100).
 - ! Usare nelle saune solamente cavi di collegamento adatti ad una temperatura di almeno 125 °C.
 - ! Nelle saune non montare le luci sopra la stufa e mantenere da questa una distanza di almeno 50 cm (fig. 1).
1. Fissare le luci sulla superficie desiderata avvitandola ai fori creati col trapano tramite le viti fornite.
 2. Fare passare il cavo di collegamento attraverso l'entrata cavi nell'alloggiamento della lampada (fig. 2)
 3. Condurre i cavi attraverso i tubi di protezione forniti.
 4. Collegare il cavo al portalamпада assicurandosi che l'alloggiamento della lampada sia connesso con il conduttore di protezione.
 5. Infine, avvitare una lampadina con max 40 W di potenza nel portalamпада in ceramica.
 6. Avvitare saldamente il vetro di protezione alla base della lampada.

SOSTITUZIONE DELLA LAMPADINA:

- ! **Attenzione pericolo di ustioni:** Prima di procedere con la sostituzione, spegnere la lampada ed attendere almeno 10 minuti perché si raffreddi.
- ! Utilizzare solamente lampadine secondo le indicazioni riportate sulla targhetta dati.
- ! **Attenzione, pericolo di scossa elettrica:** Prima di aprire la copertura, è tassativo togliere la tensione dalla lampada (straendo il fusibile) ed escludere la possibilità di una reinserzione di rete acciden
- ! Aprire la copertura per sostituire la lampadina. Svitare la lampadina difettosa ed avvitare quella nuova. Quindi riavvitare la copertura/vetro di protezione.

PULIZIA / MANUTENZIONE:

- ! **Attenzione pericolo di ustioni:** Prima di pulire la lampada attendere almeno 10 minuti perché si raffreddi.
 - ! **Attenzione:** Qualora il vetro sia crepi, sostituirlo immediatamente con un nuovo vetro.
- Passare il vetro/corpo della lampada con un panno non sfilacciante. Non utilizzare alcun detergente contenente solvente oppure abrasivo.

D	I
Schutzglas	Vetro di copertura
Silikonring	Anello in silicone
Schrauben	Viti
Lampenfassung	Portalamпада
Abdeckring	Anello di copertura
Socket	Base lampada
Dübel	Tassello

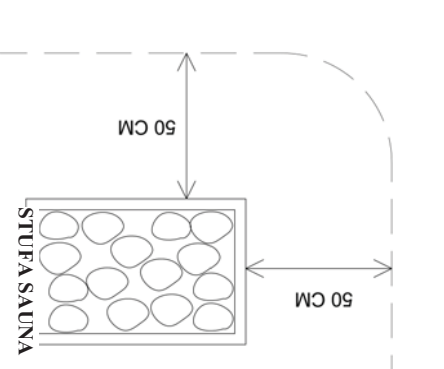
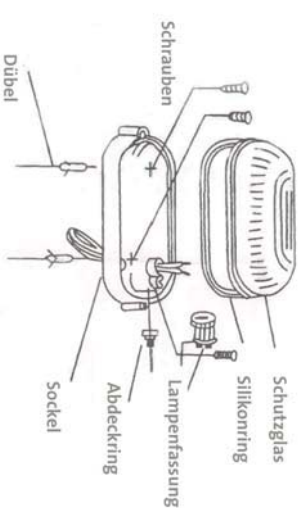

FIG. 1

FIG. 2



Montagehandleiding voor SAUNA-lamp

TECHNISCHE GEGEVENS
230 V~, 50 Hz, max. 40W, E 27

EIGENSCHAPPEN EN GEBRUIK

- Robuuste en duurzame gegoten aluminium kast
- Veiligheidsklasse IP 54

GEBRUIK

Geschikt voor gebruik in sauna's.

INSTALLATIE

Belangrijke veiligheidsinstructies:

- 1 De installatie mag uitsluitend door een elektrivakman in overeenstemming met de lokale reglementen (bijv. VDE 0100) worden uitgevoerd.
 - 1 In sauna's alleen geschikte aansluitingsgeleiders gebruiken die voor een temperatuur van minstens 125°C geschikt zijn.
 - 1 De lampen in sauna's niet boven de saunaoven monteren en een minimaalstand van 50 cm respecteren (fig. 1).
1. Bevestig de lampen op het gewenste oppervlak in passend geboorde gaten met de geleverde schroeven.
 2. Plaats de aansluitingsgeleider door de kabelgaten van de lampkast (fig. 2).
 3. Voer de geleiders door de meegeleverde beschermingslangen.
 4. Sluit de geleiders aan op de lampfitting en verbind daarbij de lampkast met de randaarde.
 5. Daarna schroeft u een gloeilamp van max. 40 W in de keramische fitting.
 6. Schroef het schutglas op de sokkel van de lamp.

LAMPEN VERVANGEN:

- 1 Let op dat u zich niet verbrandt: voor het vervangen van de lamp, moet u het licht minstens 10 minuten laten afkoelen.
 - 1 Gebruik uitsluitend lampen die overeenstemmen met de opgave op het kenplaatje.
 - 1 Let op voor elektrische schokken: voordat u de afdekkap opent, moet u de lamp zeker spanningsvrij maken (door de zekering uit te nemen) en ervoor te zorgen dat opnieuw inschakelen niet mogelijk is.
- Open de afdekkap om de lamp te vervangen. Schroef de defecte lamp ertuit en schroef een nieuwe lamp ertin. Schroef dan de afdekkap of het schutglas opnieuw vast.

SCHOONMAAK / ONDERHOUD:

- 1 Let op dat u zich niet verbrandt: voor het schoonmaken van de lamp, minstens 10 minuten laten afkoelen.
 - 1 Opgeliet een gebroken schutglas moet onmiddellijk door een nieuw schutglas worden vervangen.
- Glas/kast met pluisvrije doek afwrijven. Geen oplosmiddelen of schurende reinigingsmiddelen gebruiken.

D	NL
Schutzglas	Schutzglas
Silikonring	Siliconering
Schrauben	Schroeven
Lampenfassung	Lampfitting
Abdeckung	Afdekring
Socket	Sokkel
Dübel	Plug

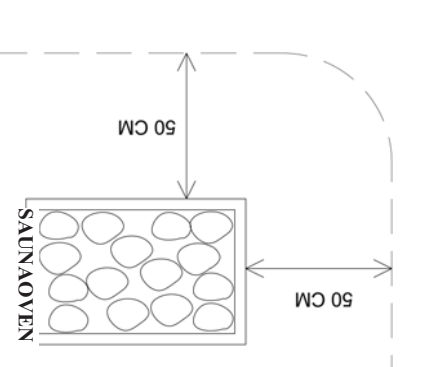

FIG. 1

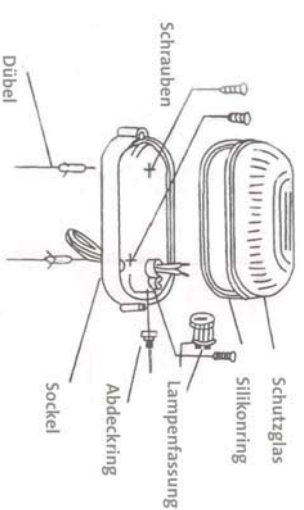

FIG. 2

Instrucțiuni de montaj pentru lămpi de saună

DATE TEHNICE

230 V~, 50 Hz, max. 40W, E 27

PROPRIETĂȚI ȘI UTILIZARE

- Carcasă robustă și stabilă din aluminiu turnat sub presiune
- Grad de protecție IP 54

UTILIZARE

Indicată pentru a fi utilizată în saune.

INSTALARE

Instrucțiuni importante de utilizare:

- ! Instalația se permite a fi executată de un electrician autorizat conform cerințelor locale (de ex. VDE 0100).
 - ! În saune se vor utiliza numai bransamente adecvate, care corespund pentru o temperatură de minim 125° C.
 - ! Lampa nu se va monta deasupra sobei saunei și se va păstra o distanță față de aceasta de minim 50 cm (fig. 1).
1. Fixați lămpile pe suprafața aleasă în găuri practice corespunzător cu șuruburile livrate.
 2. Introduceți cablul de conexiune prin gaura din carcasa lămpii (fig. 2)
 3. Introduceți conductorii prin tuburile de protecție alăturate.
 4. Introduceți conductorii la dușla lămpii, astfel încât carcasa lămpii să fie legată obligatoriu la conductorul de protecție.
 5. În continuare înșurubați un bec cu incandescență de max. 40 W în dușla ceramică.
 6. Fixați abajurul de protecție cu șuruburi pe soclul lămpii.

ÎNLOCUIREA BECULUI:

- ! Atenție pericol de arsuri: Înainte de schimbarea becului se deconectează lampa și se așteaptă minim 10 minute să se răcească.
 - ! Utilizați exclusiv becuri conform indicației de pe plăcuța de identificare.
 - ! Atenție pericol de electrocutare: Înaintea demontării abajurului de protecție se va deconecta obligatoriu lampa de la rețea (prin scoaterea siguranței) și se asigură împotriva reconectării.
- Pentru înlocuirea becului se deschide abajurul de protecție. Se deșurubează becul defect și se înșurubează altul nou. În continuare se fixează abajurul de protecție cu șuruburi.

CURĂȚARE/ÎNTREȚINERE:

- ! Atenție pericol de arsuri: Înainte de curățare se așteaptă minim 10 minute ca lampa să se răcească.
 - ! Atenție: Un abajur de protecție spart se înlocuiește imediat cu altul nou.
- Se șterge abajurul de protecție/carcasa cu o lavetă fără scame. Nu se vor utiliza soluții cu conținut de solvenți sau praf de curățat.

TEXT FIGURI:

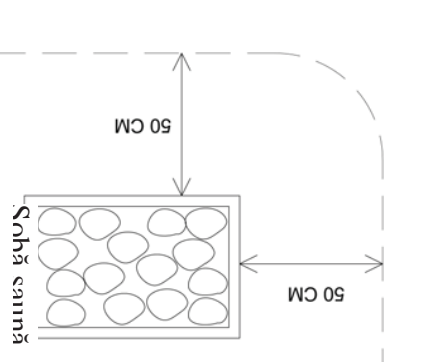

Fig. 1

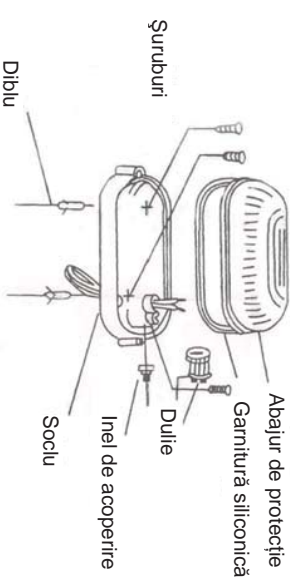

Fig. 2

Montážny návod pre svietidlo SAUNA

TECHNICKÉ ÚDAJE

230 V~, 50 Hz, max. 40 W, E 27

VLASTNOSTI A POUŽITIE

- Robustný a odolný kryt z hliníkového tlakového odliarku
- Druh istenia IP 54

POUŽITIE

Vhodné pre použitie v saunách.

INŠTALÁCIA

Dôležité bezpečnostné pokyny:

- ! Inštaláciu smie vykonať výhradne odborný elektrikár podľa miestnych požiadaviek (napr. VDE 0100).
 - ! V saunách používajte len vhodné prípojné vedenia, ktoré sú vhodné pre teploty min. 125 °C.
 - ! Svietidlo nemontujte v saune nad pecou a dodržte od nej minimálnu vzdialenosť 50 cm (obr. 1).
1. Svietidlo upevnite na požadovanej ploche v príslušných vyvrtaných otvoroch pomocou priložených skrutiek.
 2. Prípojné vedenie prevlečte cez káblový prívod krytu svietidla (obr. 2)
 3. Vodiče prevlečte cez príložené ochranné hadice.
 4. Vodiče pripievrite na objímku žiarovky, pričom kryt svietidla sa musí bezpodmienečne prepojiť s ochranným vodičom.
 5. Následne do keramickej objímky naskrutkujte žiarovku s výkonom max. 40 W.
 6. Priskrutkujte ochranné sklo na sokel svietidla.

VÝMENA ŽIAROVKY:

- ! Pozor, nebezpečenstvo popálenia: Pred výmenou osvetľovacieho prostriedku lampu vypnite a nechajte ju minimálne 10 minút vychladnúť.
- ! Použite výhradne osvetľovacie prostriedky podľa údajů na typovom štítku.
- ! Pozor, nebezpečenstvo zásahu elektrickým prúdom: Pred otvorením krytu bezpodmienečne odpojte lampu od napätia (vybraťm poisťky) a zabezpečte ju proti opätovnému zapnutiu. Pre výmenu osvetľovacieho prostriedku otvorte kryt. Vyskrutkujte chybný osvetľovaci prostriedok a naskrutkujte nový osvetľovaci prostriedok. Opät priskrutkujte kryt/ochranné sklo.

ČISTENIE/ÚDRŽBA:

- ! Pozor, nebezpečenstvo popálenia: Pred čistením nechajte lampu vychladnúť minimálne 10 minút.
 - ! Pozor: Každé rozbité sklo je neodkladne potrebné vymeniť za nové.
- Skló/kryt vyčistite handrou nepúšťajúcou chlpy. Nepoužívajte čistiace prostriedky s obsahom rozpúšťadiel alebo abrazívne čistiace prostriedky.

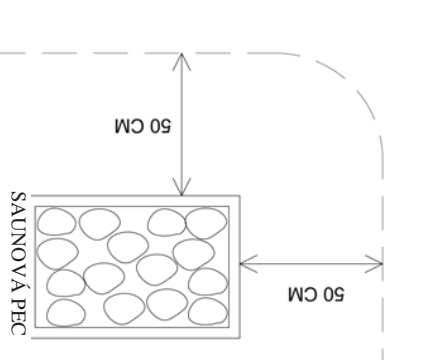

Obr. 1

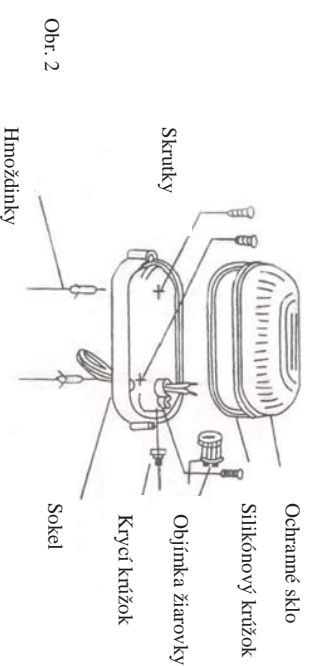

Obr. 2