

- (D) Montageanleitung
- (NL) Handleiding voor de montage
- (HU) Szerelési útmutató
- (GB) Assembly instructions
- (PL) Instrukcja montażu

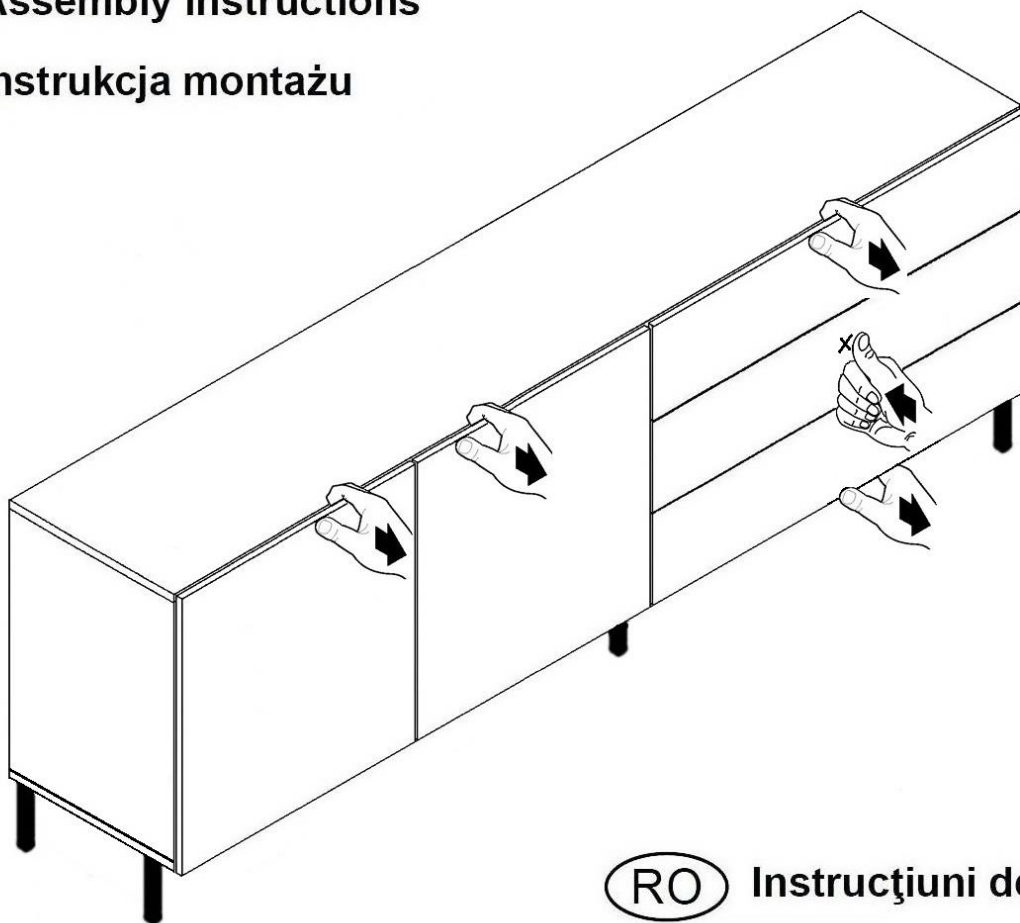

- (RO) Instrucțiuni de montaj
- (FR) Notice de montage
- (CZ) Montážní návod
- (TR) Montaj talimatı
- (IT) Istruzioni di montaggio
- (SK) Návod na montáž
- (RU) Инструкция по монтажу

**Service • Assistenza • Dienstverlening • Serwis
Servis • Szerviz • Сервисная служба**

Name • Nom • Nome • Naam •
Nazwa • Jméno • Názov • Név •
Denumire • Ísim • Название

Nr. • No. • N° • Номер • Č • Sz

Typ • Type • Тір • Тіpus • Тіро •
Тип

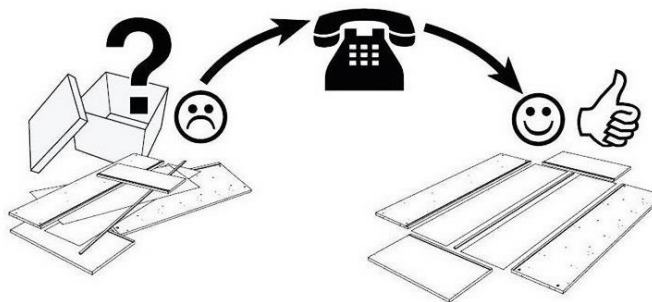
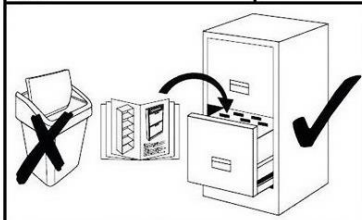

1 ≠ **3a**

1	1x	ca. 1520 x 330 mm	8	2x	ca. 365 x 300 mm
2	1x	ca. 1501 x 502 mm	9	2x	ca. 524 x 377 mm
3a	1x	ca. 1520 x 330 mm	10	3x	ca. 757 x 172 mm
4a	1x	ca. 490 x 330 mm	11-L	3x	ca. 310 x 88 mm
5a	1x	ca. 490 x 315 mm	11-M	3x	ca. 695 x 88 mm
6a	1x	ca. 490 x 315 mm	11-R	3x	ca. 310 x 88 mm
7a	1x	ca. 490 x 330 mm	12	3x	ca. 707 x 307 mm

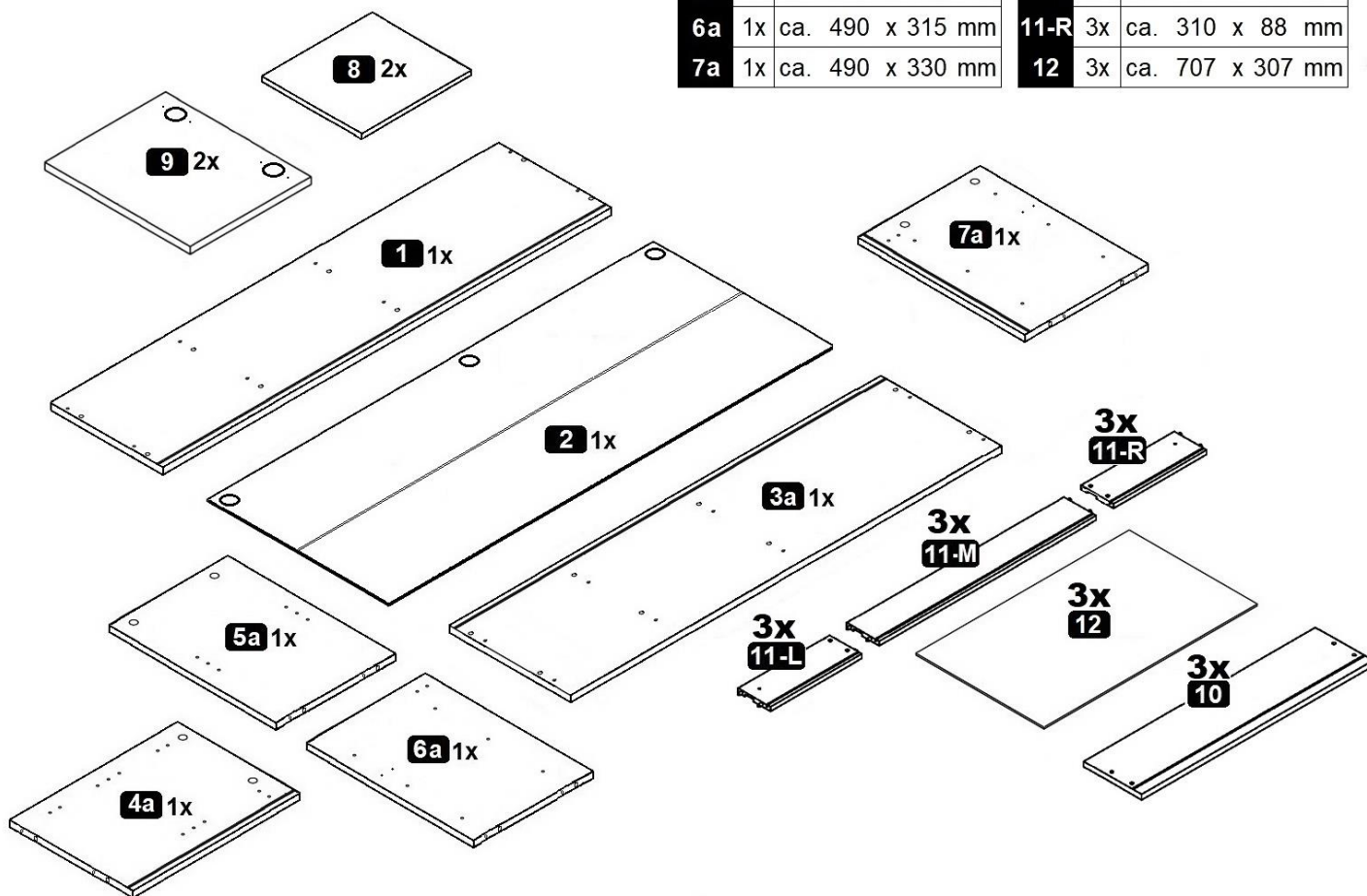

A 8,0 x 30 mm 16x	B 8x	C 8x	D 2x	E 3,5 x 9,5 mm 4x	F 1x	G Ø12,7x3,5mm 6x
H 17x310 mm 6x	I 6,3 x 13 mm 18x	J M4,0 x 9 mm 6x	K 8x	L 2x	M h=2 2x	N Ø35 Kr.0 3,5x13 mm 2x
O 2,7 x 20 mm 8x	P 2x	X M4x16 mm 10x	Y 4,0x17 mm 15x	Z 5x	U 5,0 x 50 mm 8x	

MA1X



1

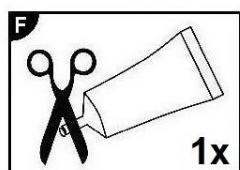
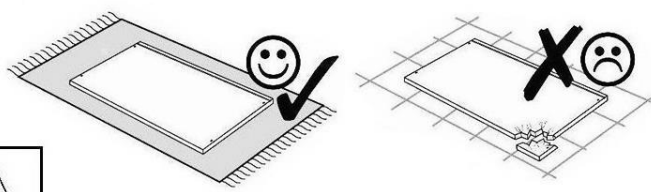

- D Leim
- GB Glue
- FR Colle
- IT Colla
- NL Lijm
- PL Klej
- CZ Lepidlo
- SK Glej
- HU Enyv
- RO Adeziv
- TR Tutkal
- RU Клей

3x

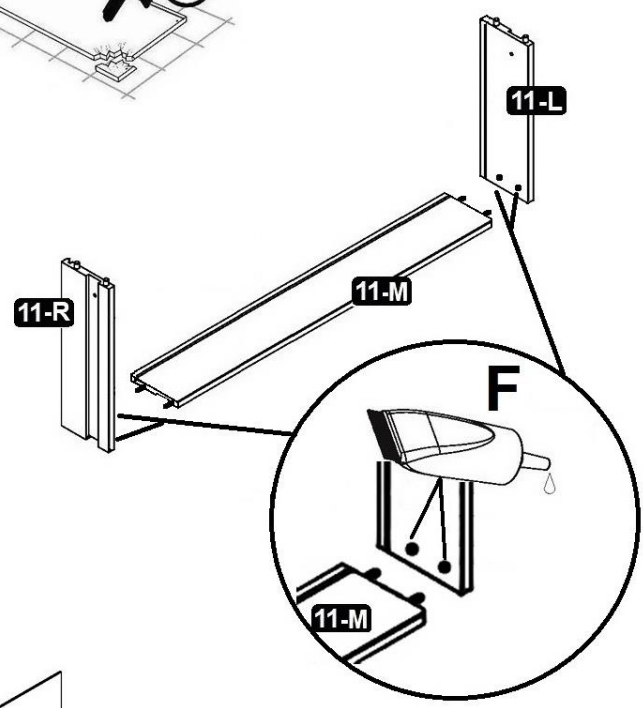

3x

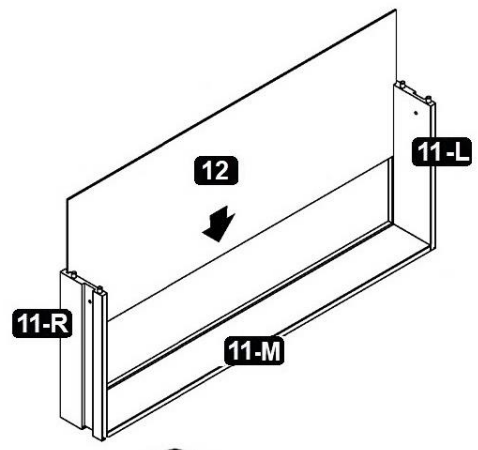

3x

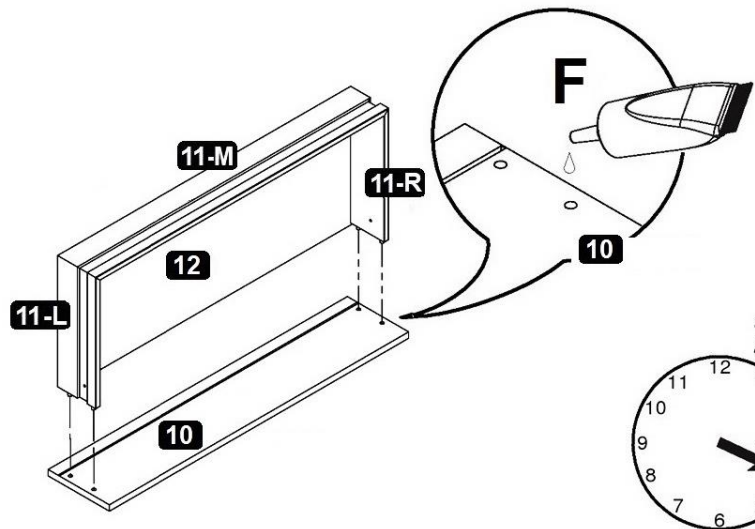

20min

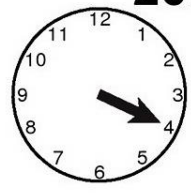



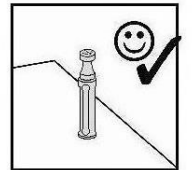
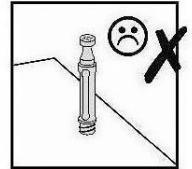
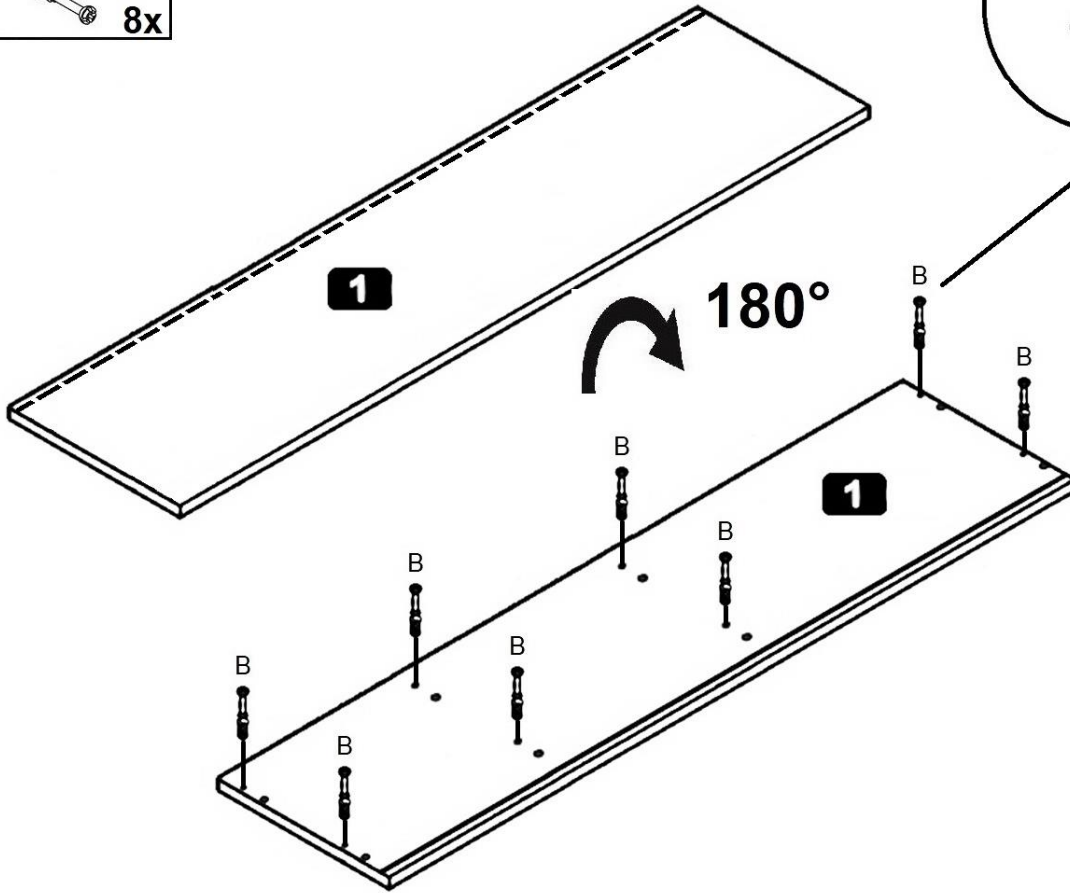
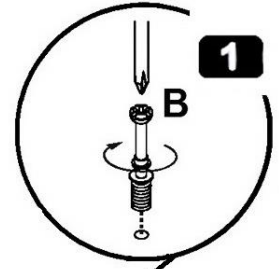
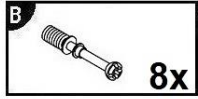
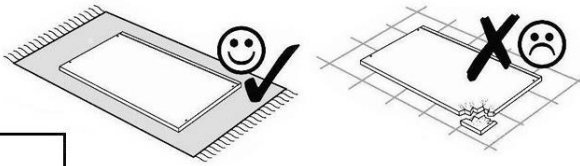



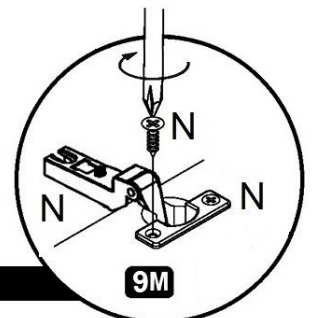
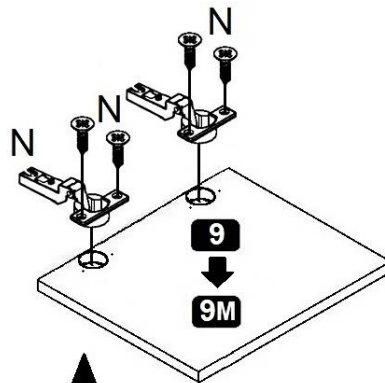
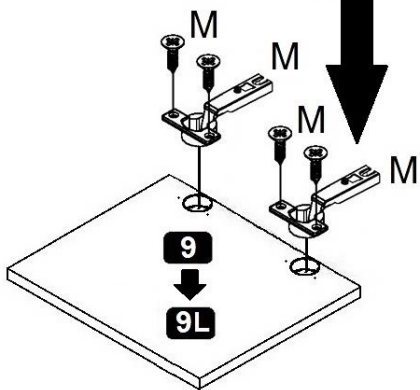
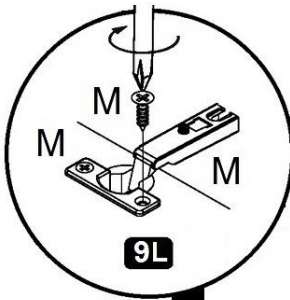
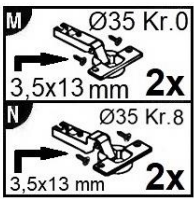

2



3



4

A 8,0 x 30 mm  16x	C  8x	H 17x310 mm  6x	I 6,3 x 13 mm  12x	D  2x	E 3,5 x 9,5 mm  4x
L h=2  2x	P h=4  2x				

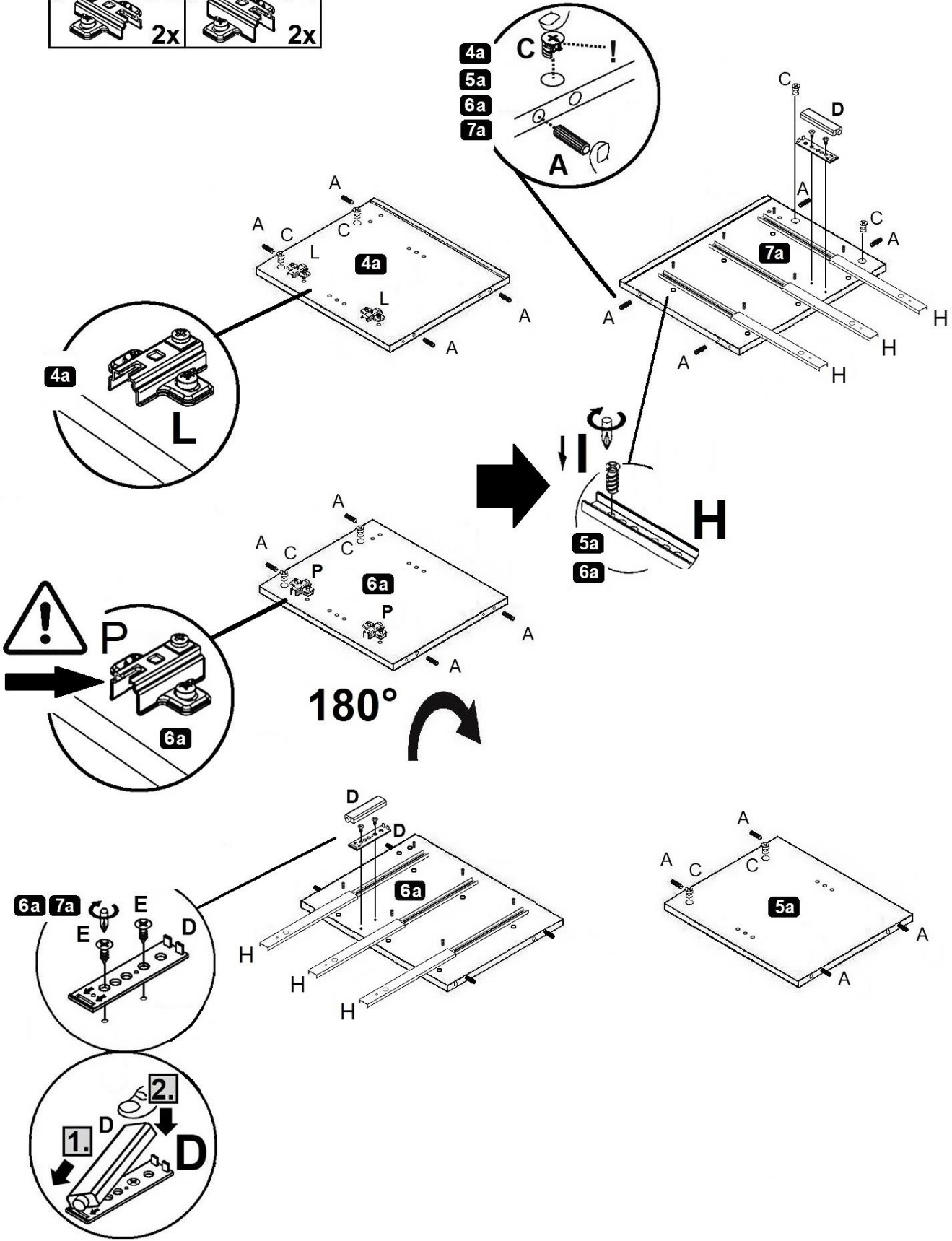

5

U 5,0 x 50 mm
8x

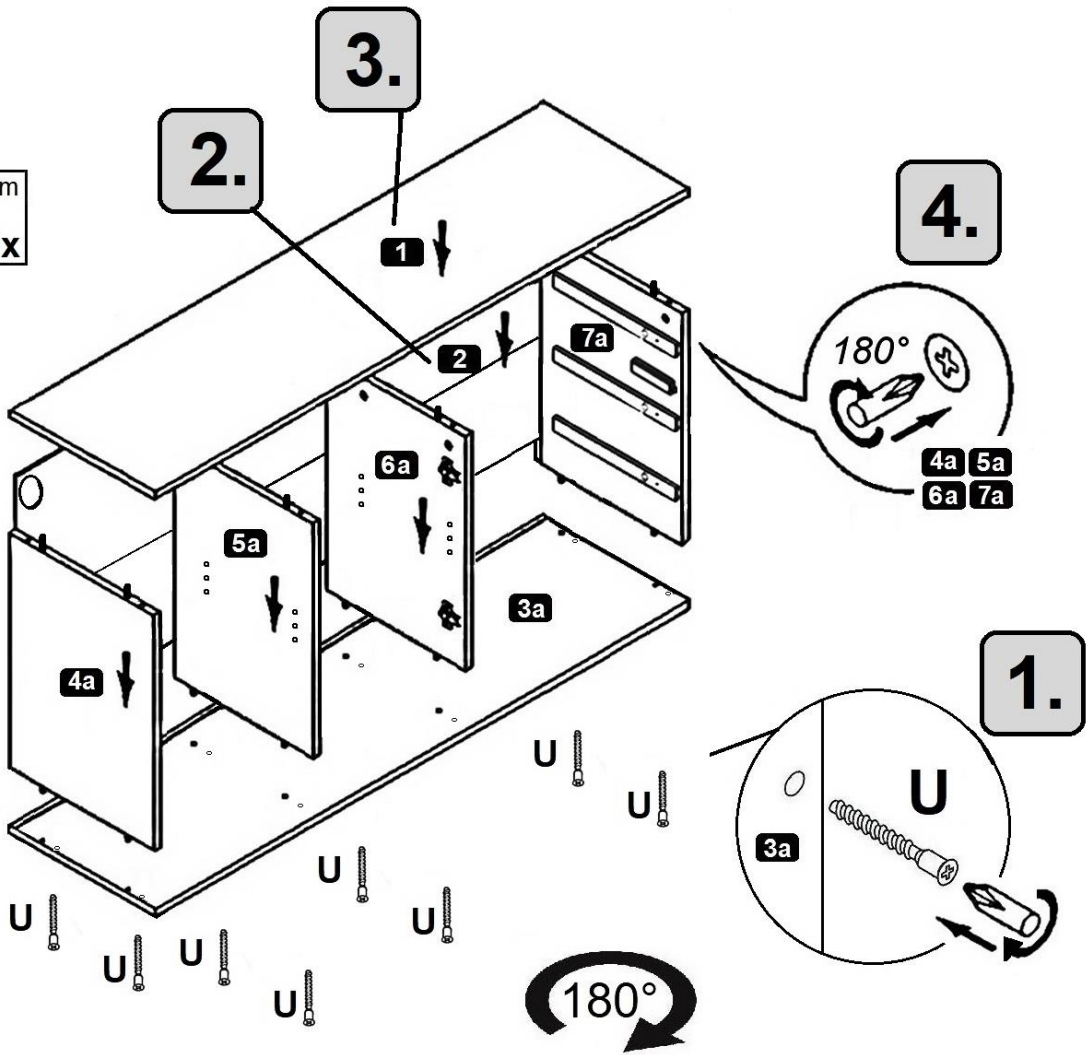

6

o 2,7 x 20 mm
8x

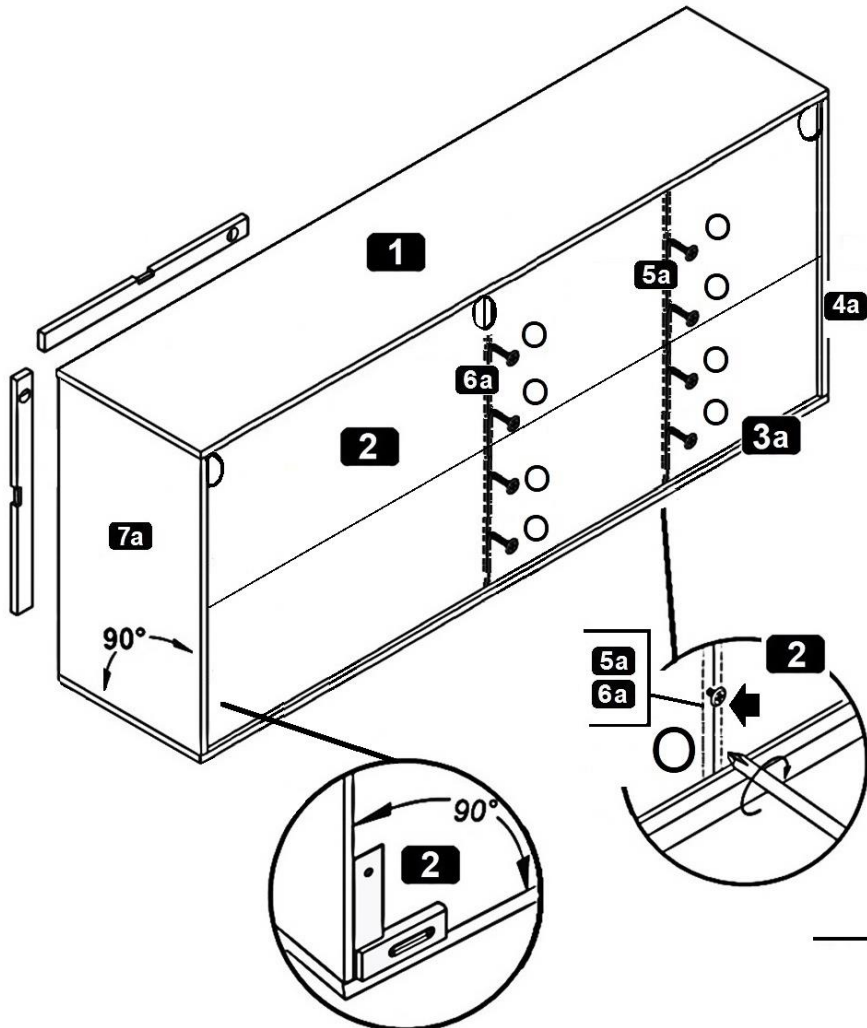

7

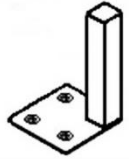

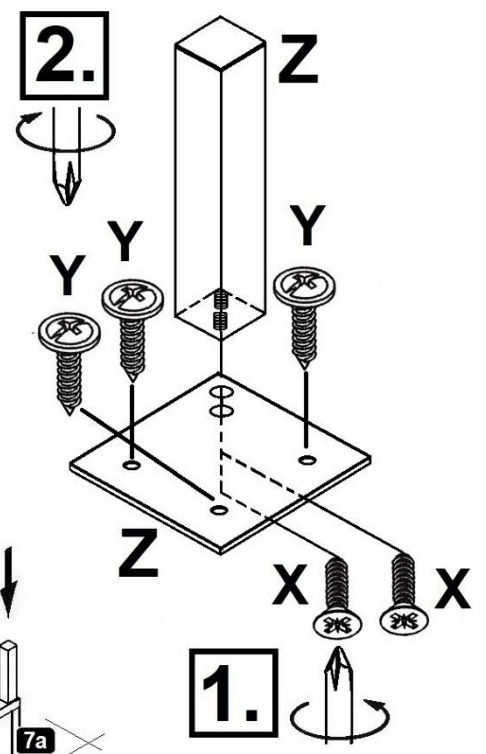
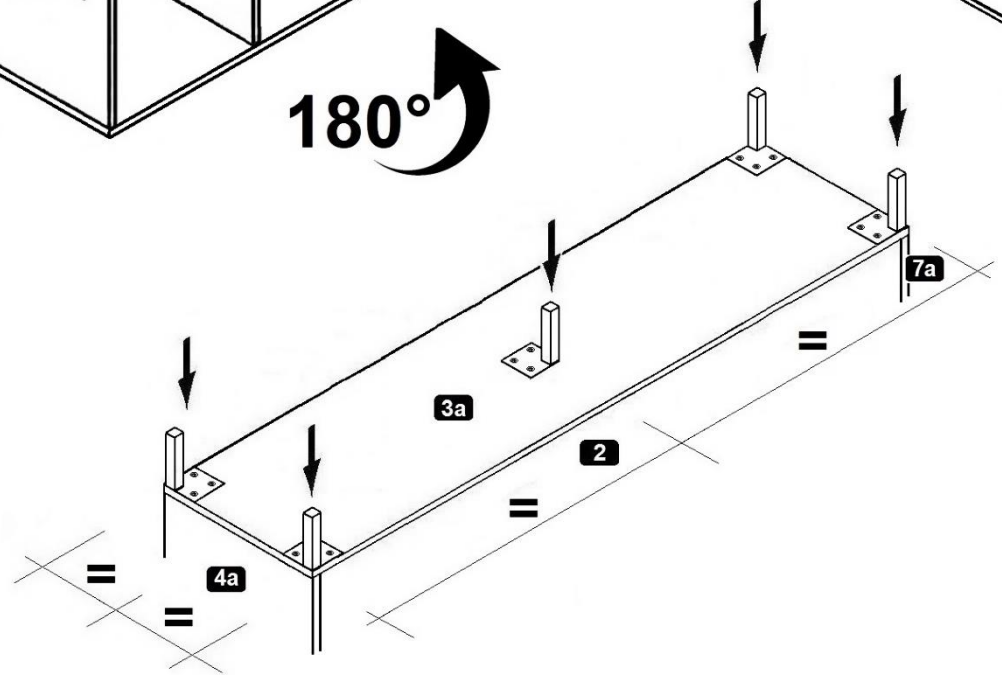
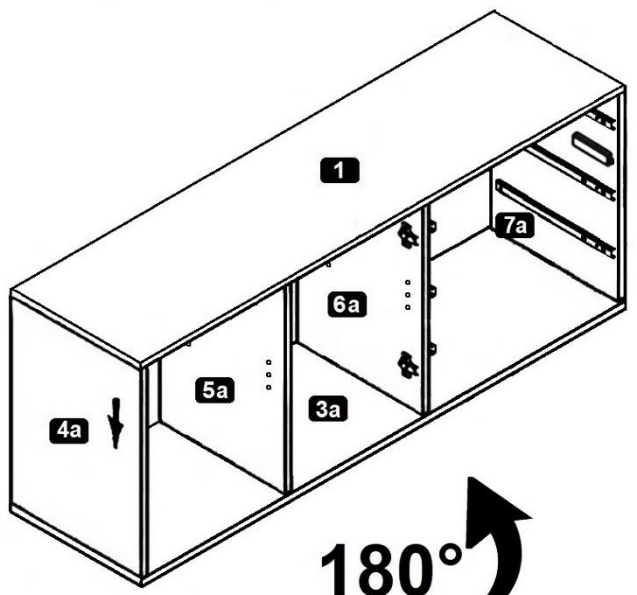

- | | |
|--|---|
| (D) Montage der Metallfüße | (CZ) Montáž kovových nožiček |
| (GB) Assembly of the metal feet | (RO) Asamblarea picioarelor metalice |
| (FR) Assemblage des pieds métalliques | (HU) A fém lábak összeszerelése |
| (IT) Montaggio dei piedini in metallo | (SK) Montáž kovových nožičiek |
| (NL) Montage van de metalen voetjes | (TR) Metal ayakların montajı |
| (PL) Montaż metalowych nóżek | (RU) Asamblarea picioarelor metalice |

- | | | |
|---------------------|----------------------|-----------|
| M4x16 mm 10x | 4,0x17 mm 15x | 5x |
|---------------------|----------------------|-----------|



8

- G Ø12,7x3,5mm
 4x
- K  8x
- J M4,0 x 9 mm
 6x

1.

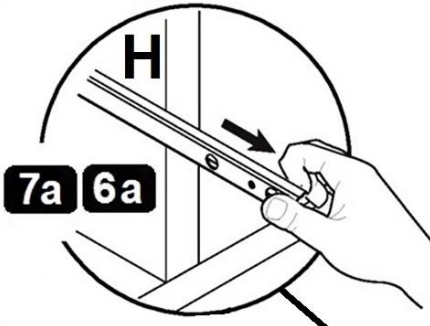

3.

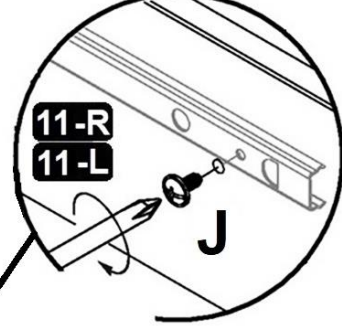

4a
5a
6a

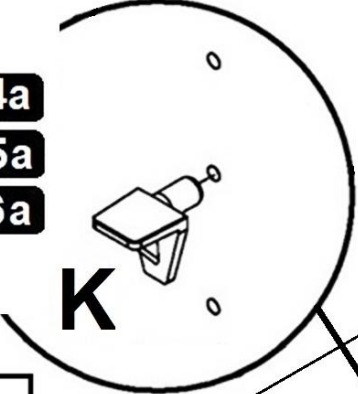

5.

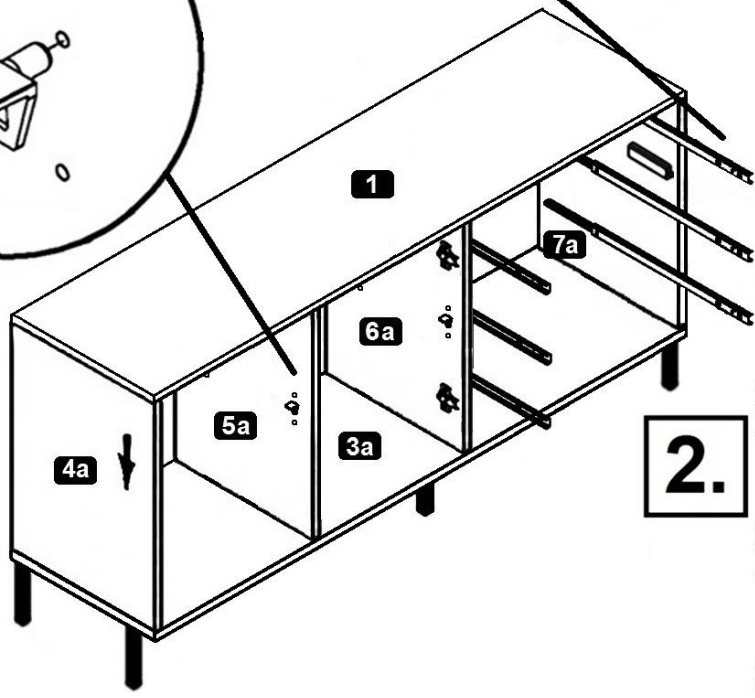

2.

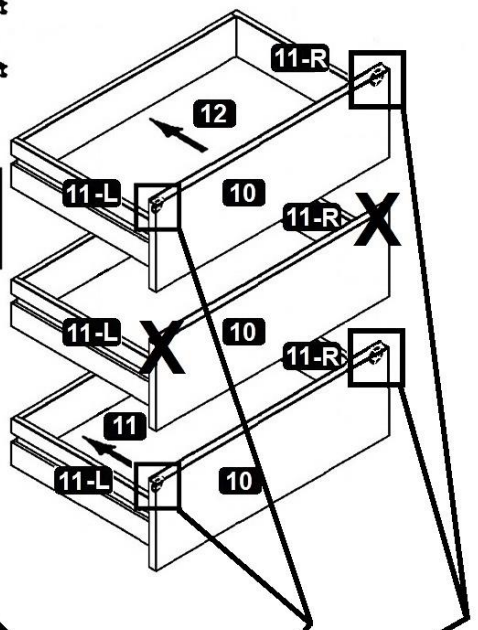

- (D) Wichtig! Bitte genau hier anbringen!
- (GB) Important! Please attach right here!
- (FR) Important! Veuillez joindre ici!
- (RU) Важно! Пожалуйста, прикрепите прямо здесь!
- (TR) Önemli! Lütfen buraya ekleyin!
- (IT) ! importante Si prega di allegare proprio qui!
- (NL) Belangrijk! Voeg hier toe!
- (PL) Ważne! Dołącz tutaj!
- (CZ) Důležité! Připojte se prosím zde!
- (RO) Important! Vă rugăm să atașați chiar aici!
- (HU) Fontos! Kérjük, csatolja ide!
- (SK) Dôležité! Pripojte, prosím, tu!

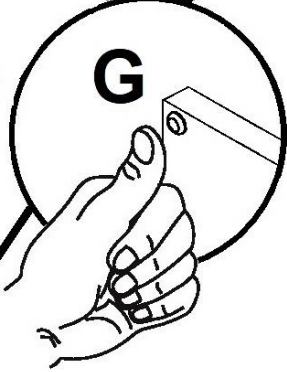

4.

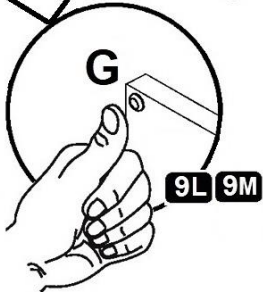
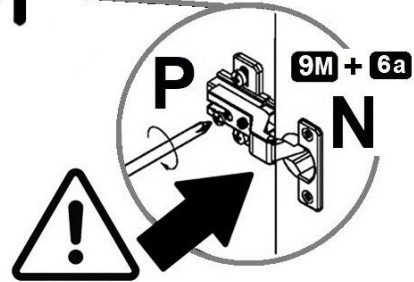
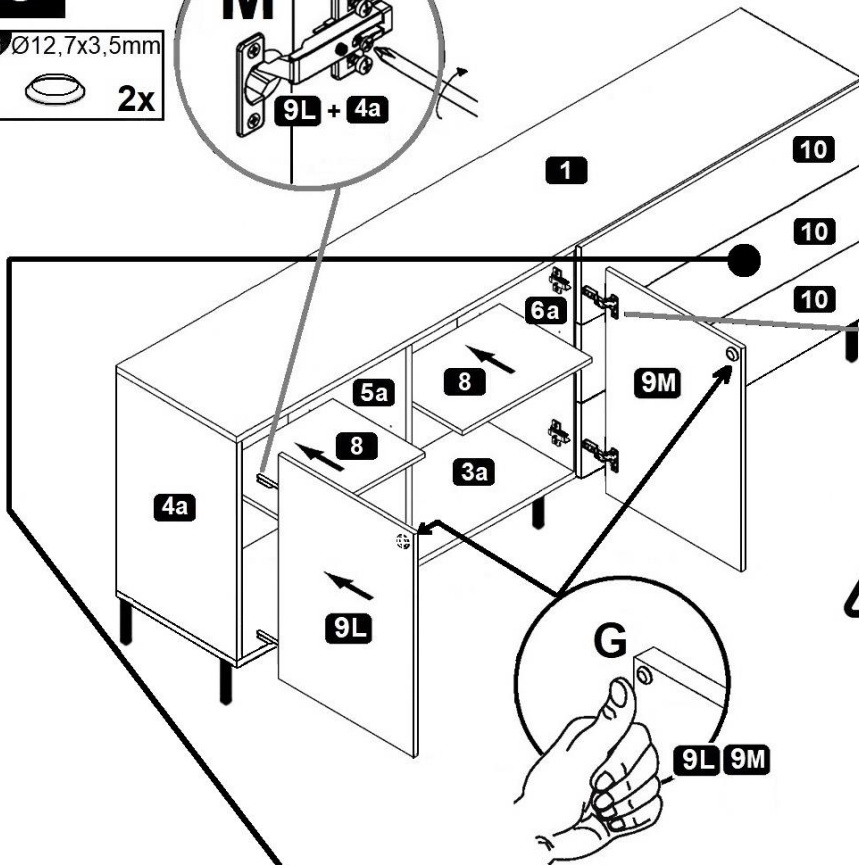
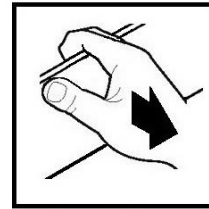
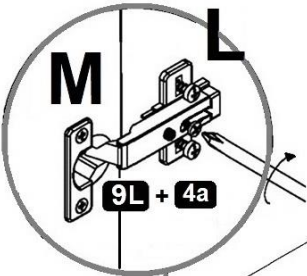
9G Ø12,7x3,5mm
2x

➔ **11 / 11**

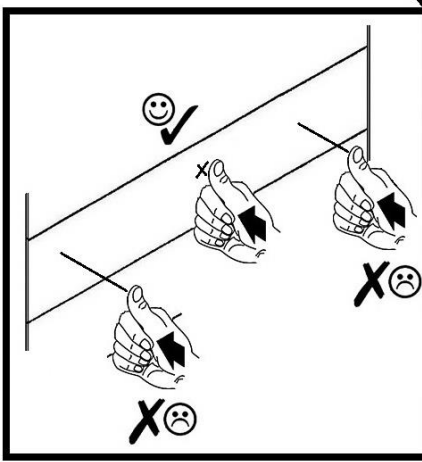
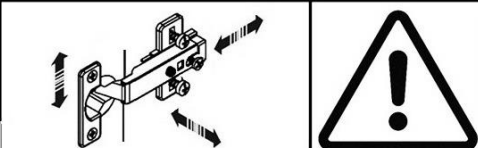



➔ **10 / 11**

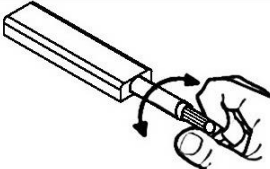

- (D) Push-To-Open einstellen
- (GB) Adjusting the Push-To-Open
- (FR) Régler les Push-To-Open
- (IT) Sistemare Push-To-Open
- (NL) Push-To-Open instellen
- (PL) Nastawić Push-To-Open
- (CZ) Vyrovnajte dvířka (seřid'te závěsy)
- (RO) Nastavenie dverí (nastavenie závesov)
- (HU) Állítsa be az ajtókat (állítsa be a zsanérokot)
- (SK) Reglare uši (ajustare balamale)
- (TR) Push-To-Open ayarlanması
- (RU) Регулировка Push-To-Open

- (D) Türen einstellen (Scharniere justieren)
- (GB) Adjusting the doors (adjusting the hinges)
- (FR) Régler les portes (ajuster les charnières)
- (IT) Sistemare le porte (regolare le cerniere)
- (NL) Deuren instellen (scharnieren afstellen)
- (PL) Nastawić drzwi (wyregulować zawiasy)
- (CZ) Vyrovnajte dvířka (seřid'te závěsy)
- (RO) Nastavenie dverí (nastavenie závesov)
- (HU) Állítsa be az ajtókat (állítsa be a zsanérokot)
- (SK) Reglare uši (ajustare balamale)
- (TR) Kapıların ayarlanması (menteşelerin seviye ayarı)
- (RU) Регулировка дверей (регулировка шарнира)

		
(D) Push-To-Open einstellen	(CZ) Vyrovnajte Push-To-Open	(RO) Nastavenie Push-To-Open
(GB) Adjusting the Push-To-Open	(HU) Állítsa be az Push-To-Open	(SK) Reglare Push-To-Open
(FR) Régler les Push-To-Open	(TR) Push-To-Open ayarlanması	(RU) Регулировка Push-To-Open
(IT) Sistemare Push-To-Open		
(NL) Push-To-Open instellen		
(PL) Nastawić Push-To-Open		

1.

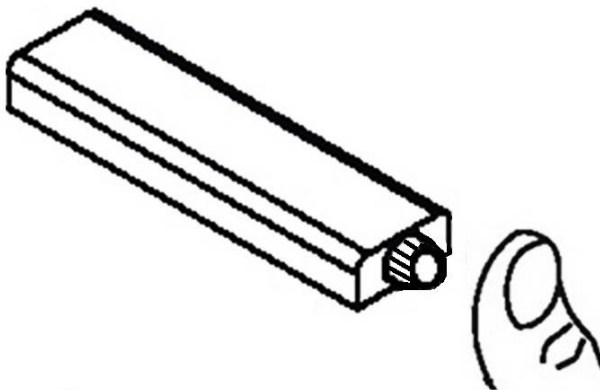

2.

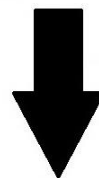
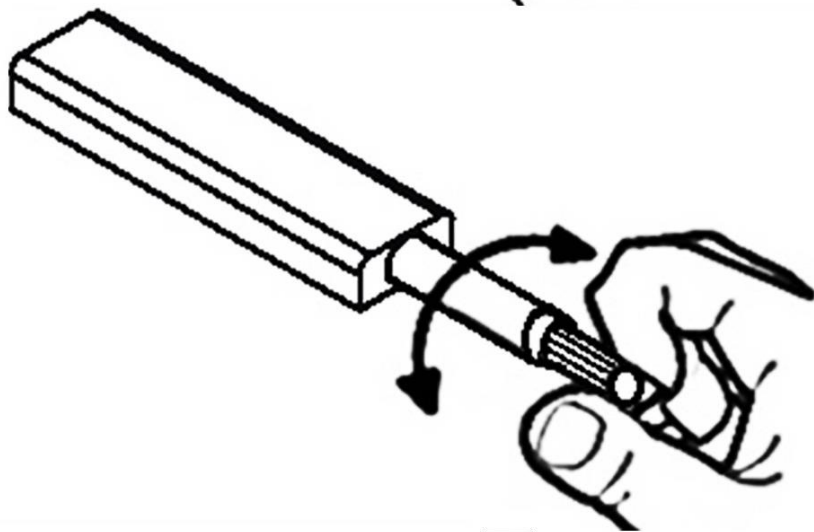

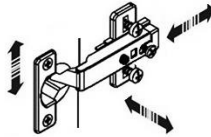

- | | |
|--|---|
| (D) Türen einstellen
(Scharniere justieren) | (CZ) Vyrovnajte dvířka
(seřid'ťe závěsy) |
| (GB) Adjusting the doors
(adjusting the hinges) | (RO) Nastavenie dverí
(nastavenie závesov) |
| (FR) Régler les portes
(ajuster les charnières) | (HU) Állítsa be az ajtókat
(állítsa be a zsanérokot) |
| (IT) Sistemare le porte
(regolare le cerniere) | (SK) Reglare uši
(ajustare balamale) |
| (NL) Deuren instellen
(scharnieren afstellen) | (TR) Kapıların ayarlanması
(menteşelerin seviye ayarı) |
| (PL) Nastawić drzwi
(wyregulować zawiasy) | (RU) Регулировка дверей
(регулировка шарнира) |

