

- (D) Montageanleitung
- (NL) Handleiding voor de montage
- (HU) Szerelési útmutató
- (GB) Assembly instructions

- (PL) Instrukcja montażu
- (RO) Instrucțiuni de montaj
- (FR) Notice de montage
- (CZ) Montážní návod
- (TR) Montaj talimatı
- (IT) Istruzioni di montaggio
- (SK) Návod na montáž
- (RU) Инструкция по монтажу

Service • Assistenza • Dienstverlening • Serwis  
 Servis • Szerviz • Сервисная служба

Name • Nom • Nome • Naam • Nazwa • Jméno • Názov • Név • Denumire • İsim • Название	
Nr. • No. • N° • Номер • Č • Sz	
Typ • Type • Тип • Típus • Tipo • Тип	

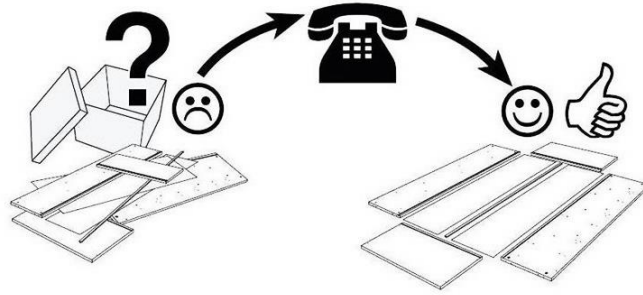
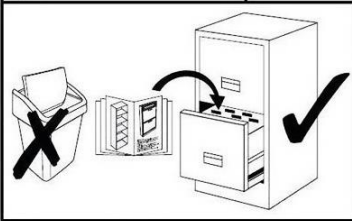

<b>1</b>	1x	ca. 1140 x 330 mm
<b>2a</b>	1x	ca. 1121 x 330 mm
<b>3b</b>	1x	ca. 1140 x 330 mm

<b>4b</b>	1x	ca. 318 x 330 mm
<b>50b</b>	2x	ca. 318 x 315 mm
<b>6</b>	3x	ca. 352 x 377 mm
<b>7b</b>	1x	ca. 318 x 330 mm

**1** ≠ **3b**

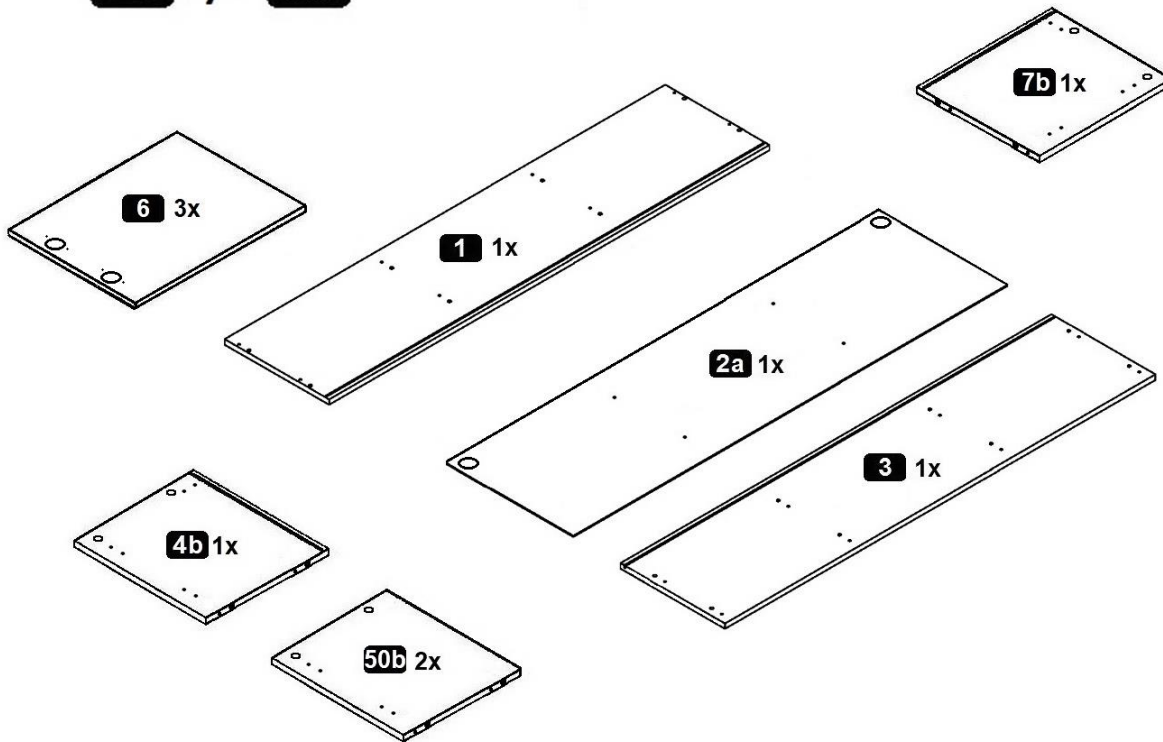

<b>A</b> 8,0 x 30 mm <b>16x</b>	<b>B</b> <b>8x</b>	<b>C</b> <b>8x</b>	<b>F</b> 5,0 x 50 mm <b>8x</b>	<b>G</b> h=4 <b>2x</b>
<b>H</b> Ø35 Kr.0 3,5x13 mm <b>4x</b>	h=2 <b>4x</b>	<b>K</b> 2,7 x 20 mm <b>4x</b>	<b>L</b> Ø35 Kr.8 3,5x13 mm <b>2x</b>	
<b>X</b> M4x16 mm <b>10x</b>	<b>Y</b> 4,0x17 mm <b>15x</b>	<b>Z</b> <b>5x</b>		

**1**

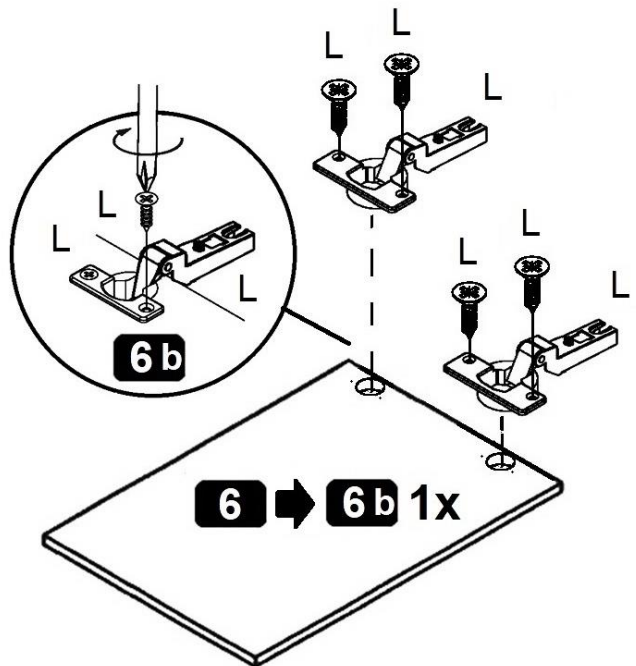
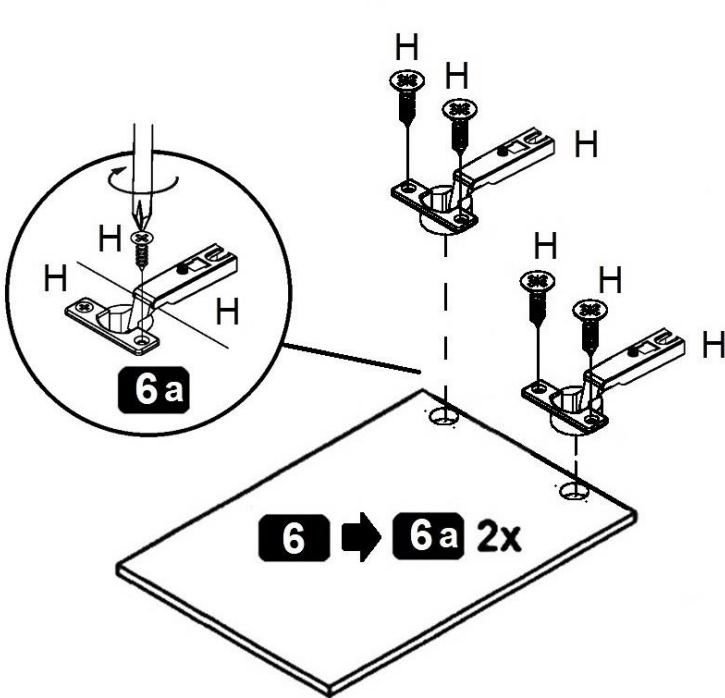
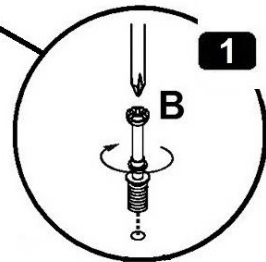
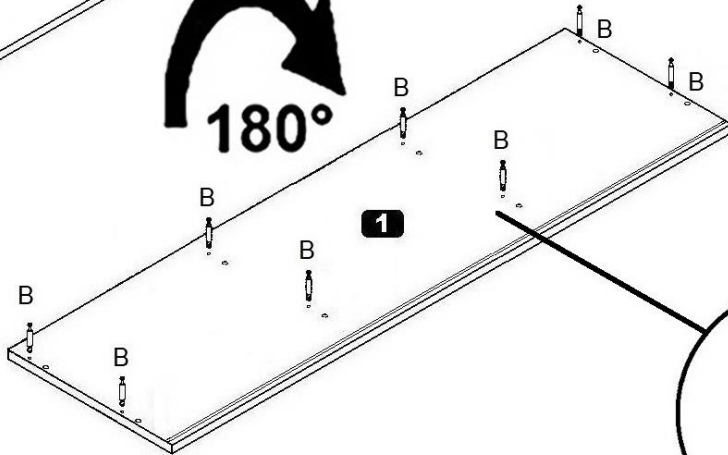
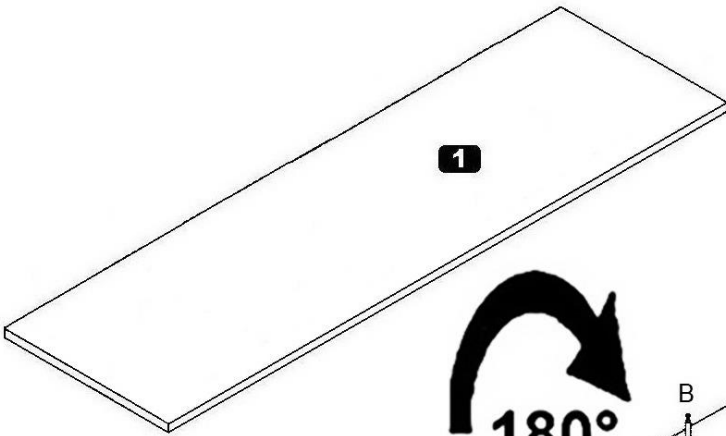
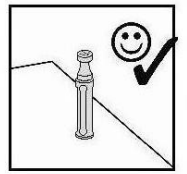
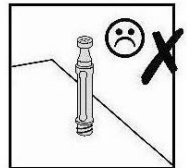
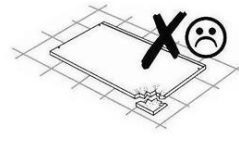
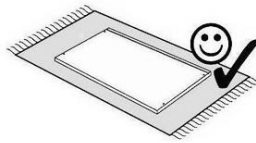
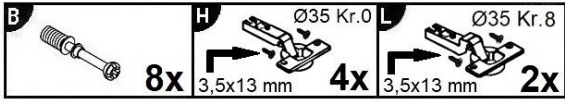

# 2

<b>A</b> 8,0 x 30 mm	<b>C</b>	<b>G</b> h=4	<b>I</b> h=2
16x	8x	2x	4x

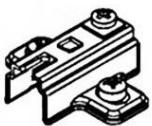
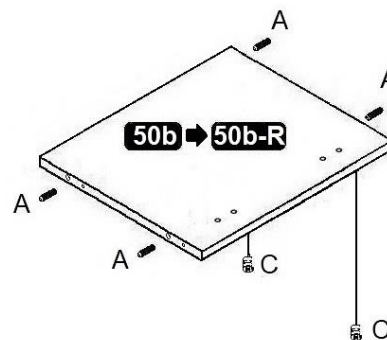
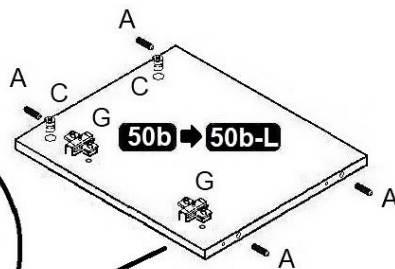
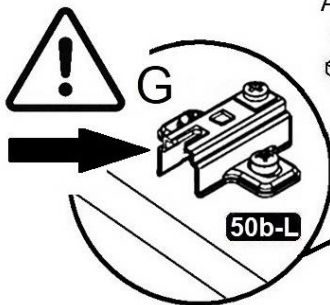
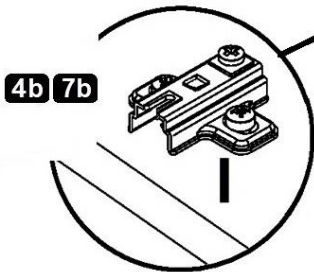
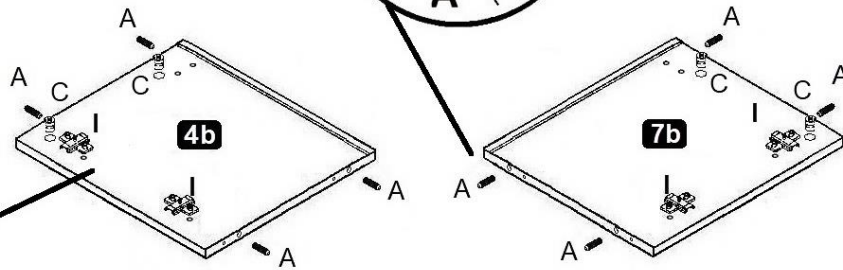
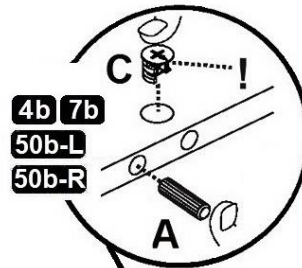
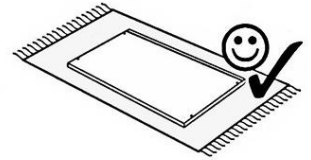
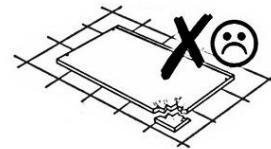

- (D) Links- oder Rechtsmontage
- (GB) Left or right mounting
- (FR) Montage à gauche ou à droite
- (IT) Montaggio sinistro o destro
- (NL) Links of rechts montage
- (PL) Montaż lewy lub prawy

- (CZ) Levá nebo pravá montáž
- (RO) Montare stanga sau dreapta
- (HU) Bal vagy jobb szerelés
- (SK) Ľavá alebo pravá montáž
- (TR) Sol veya sağ montaj
- (RU) Левый или правый монтаж

**3**

F 5,0 x 50 mm  
8x

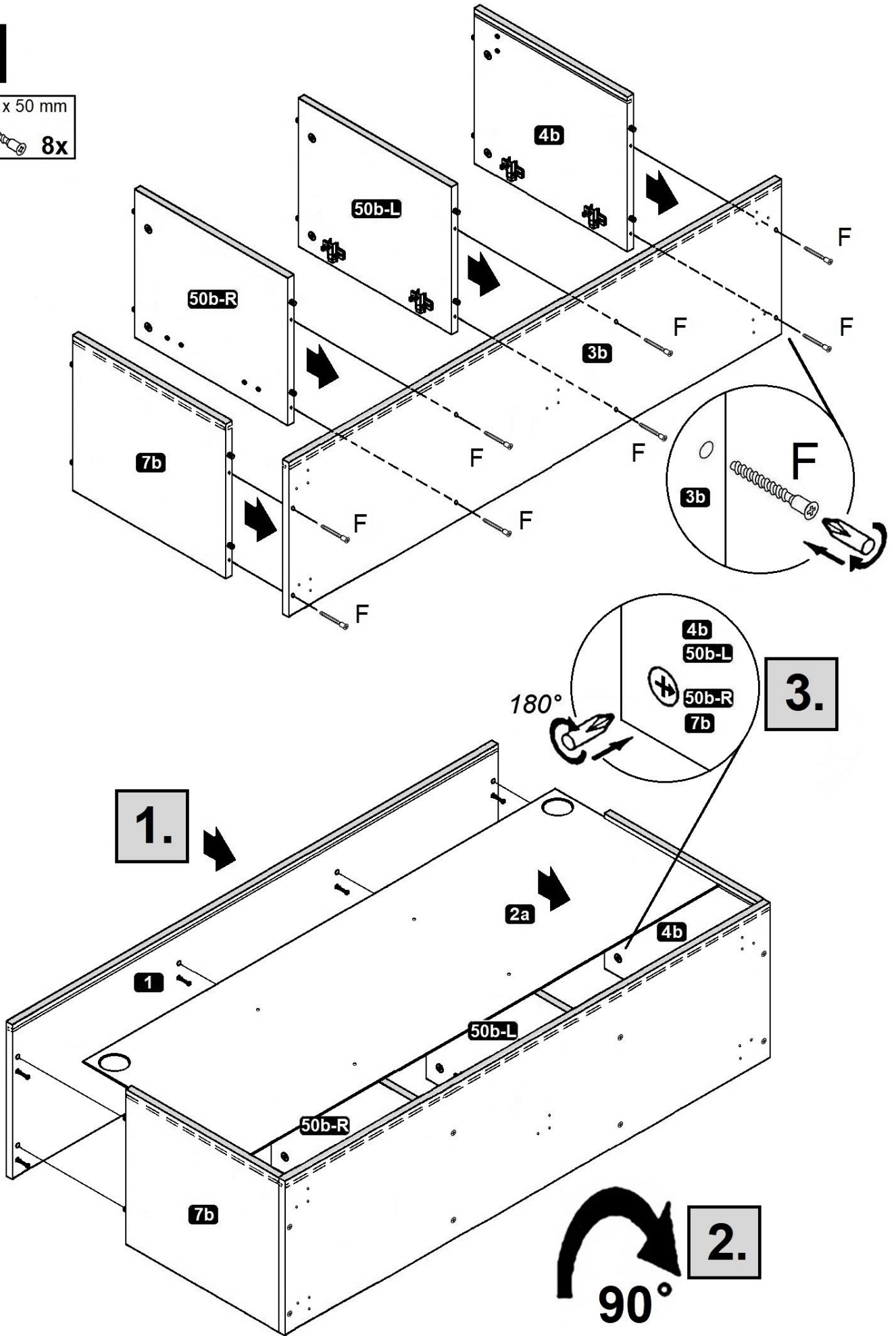

**4**

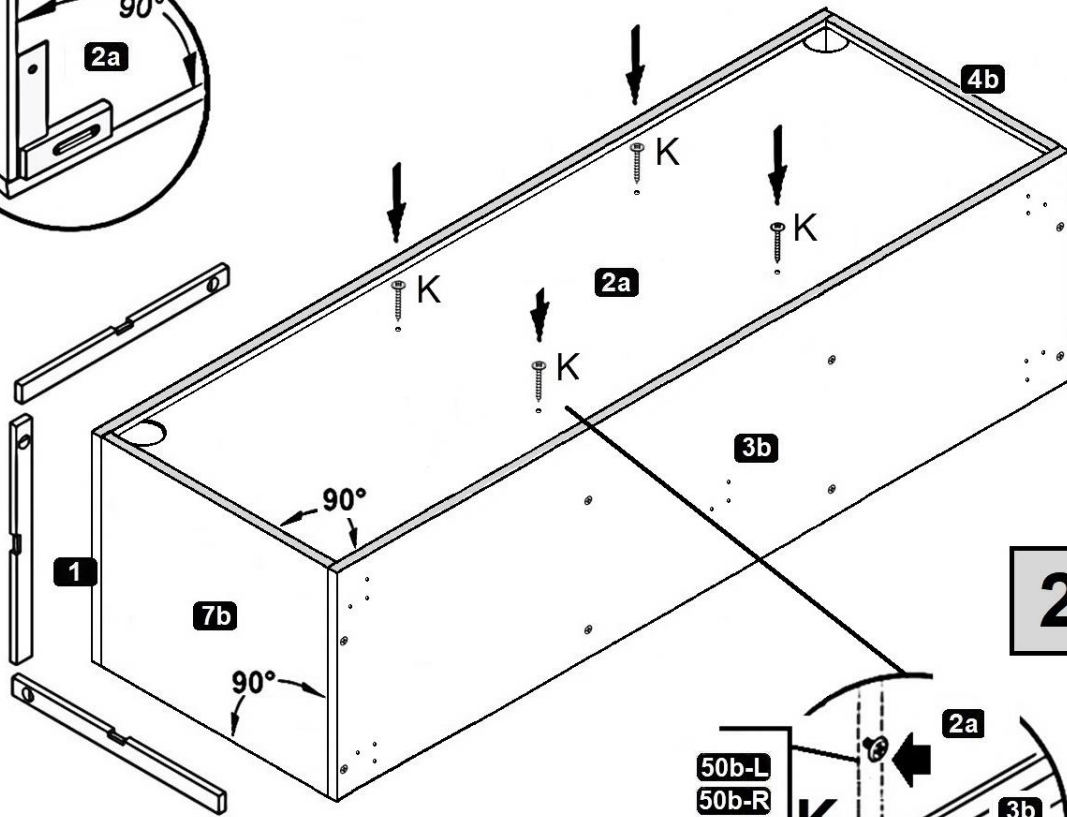
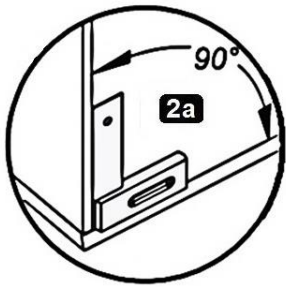
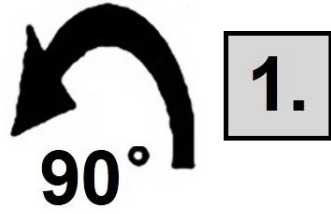
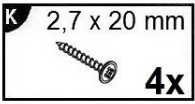

**2.**

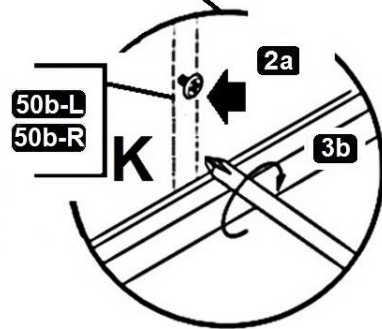

**3.**

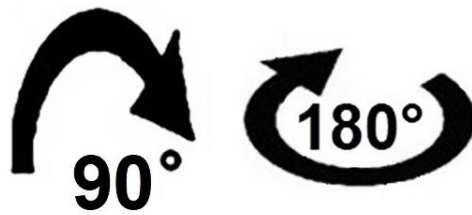

# 5

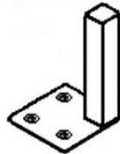

(D) Montage der Metallfüße

(GB) Assembly of the metal feet

(FR) Assemblage des pieds métalliques

(IT) Montaggio dei piedini in metallo

(NL) Montage van de metalen voetjes

(PL) Montaż metalowych nóżek

(CZ) Montáž kovových nožiček

(RO) Asamblarea picioarelor metalice

(HU) A fém lábak összeszerelése

(SK) Montáž kovových nožičiek

(TR) Metal ayakların montajı

(RU) Asamblarea picioarelor metalice

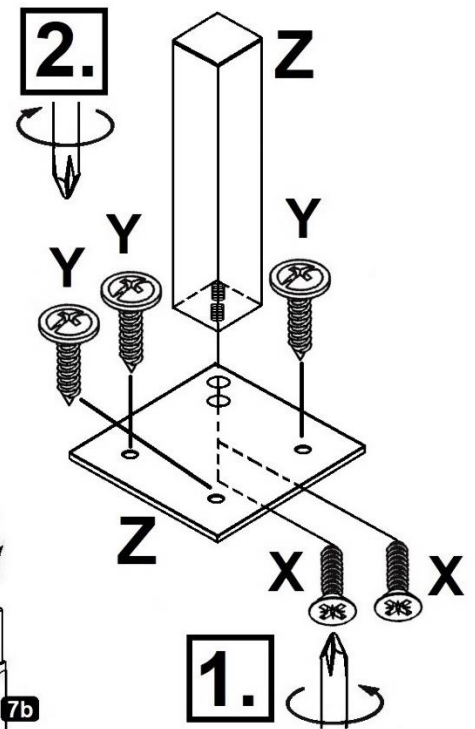
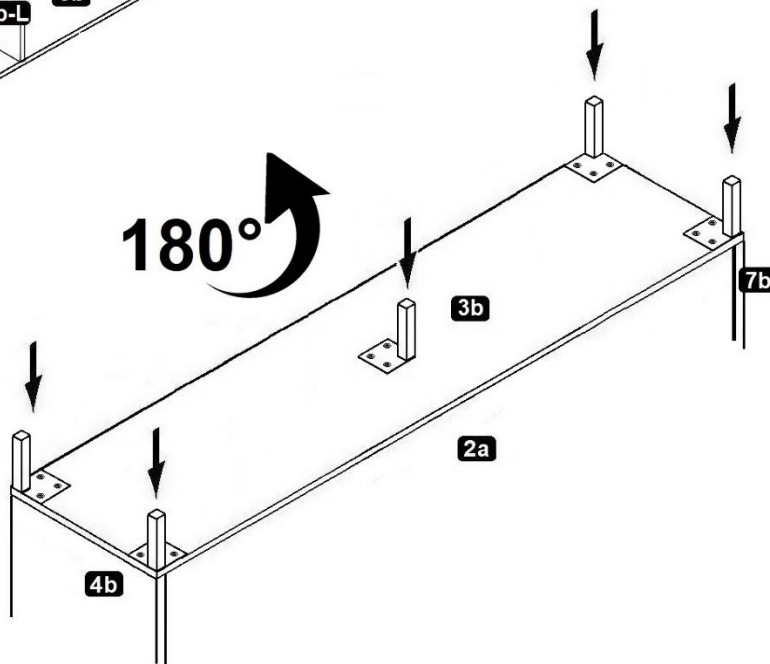
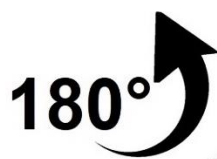
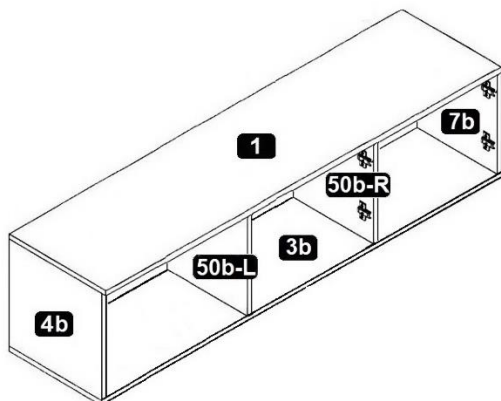

6

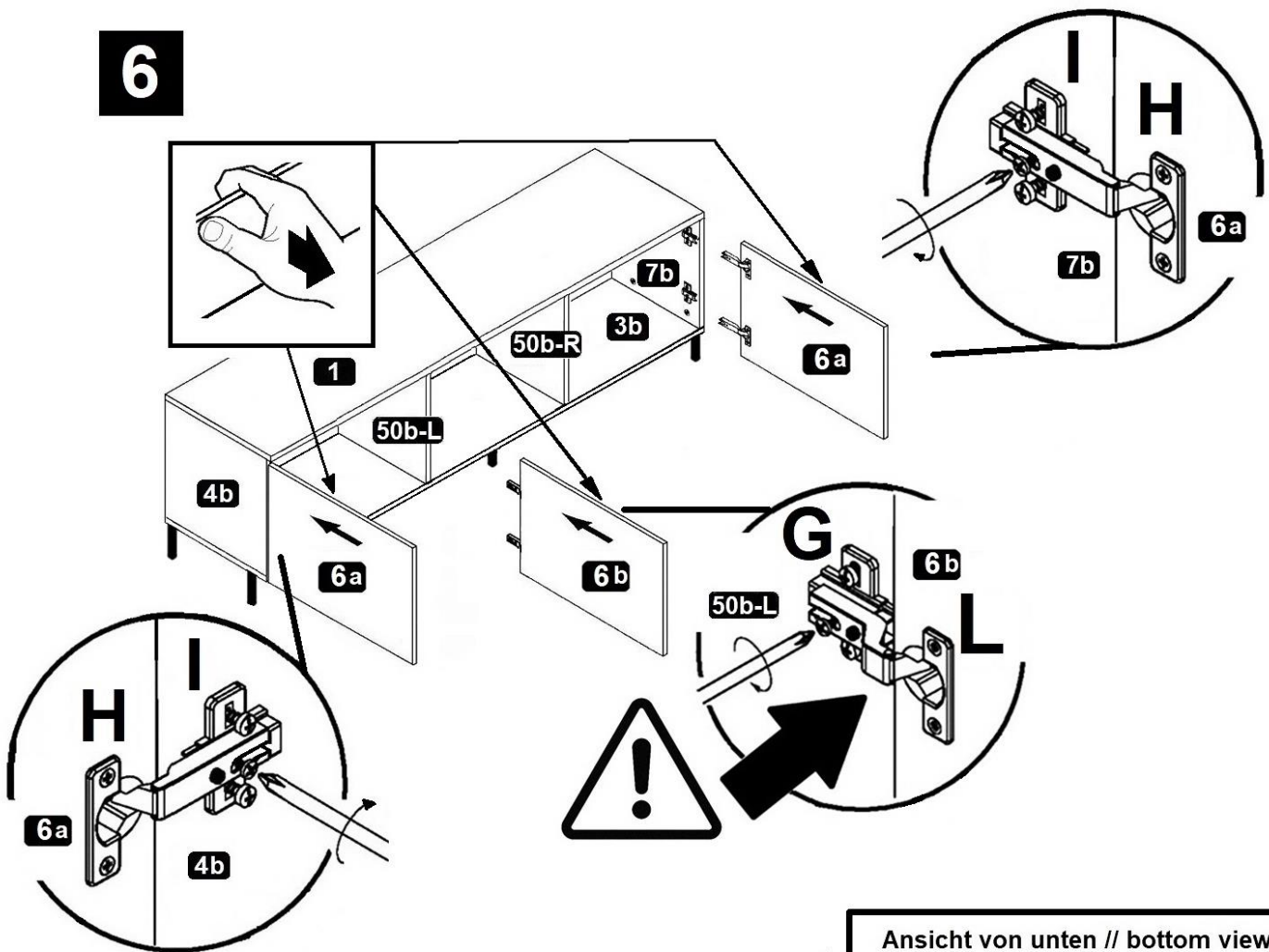

Ansicht von unten // bottom view

D

Bitte in Schraubenführung stecken. Eventuell Verstellerschraube leicht herausdrehen.

GB

Please put in screw guide. If necessary, unscrew the adjusting screw slightly.

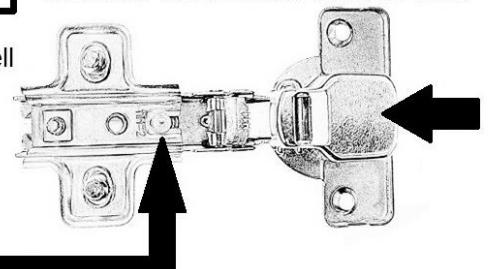

➔ 9 / 9

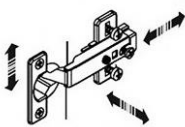

D

Türen einstellen  
(Scharniere justieren)

GB

Adjusting the doors  
(adjusting the hinges)

FR

Régler les portes  
(ajuster les charnières)

IT

Sistemare le porte  
(regolare le cerniere)

NL

Deuren instellen  
(scharnieren afstellen)

PL

Nastawić drzwi  
(wyregulować zawiasy)

CZ

Vyrovnejte dvířka  
(seřid'te závěsy)

RO

Nastavenie dverí  
(nastavenie závesov)

HU

Állítsa be az ajtókat  
(állítsa be a zsanérokat)

SK

Reglare uși  
(ajustare balamale)

TR

Kapıların ayarlanması  
(menteşelerin seviye ayarı)

RU

Регулировка дверей  
(регулировка шарнира)



7

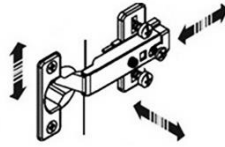

(D) Türen einstellen  
(Scharniere justieren)

(GB) Adjusting the doors  
(adjusting the hinges)

(FR) Régler les portes  
(ajuster les charnières)

(IT) Sistemare le porte  
(regolare le cerniere)

(NL) Deuren instellen  
(scharnieren afstellen)

(PL) Nastawić drzwi  
(wyregulować zawiasy)

(CZ) Vyrovnajte dvířka  
(seřid'te závěsy)

(RO) Nastavenie dverí  
(nastavenie závesov)

(HU) Állítsa be az ajtókat  
(állítsa be a zsanérokot)

(SK) Reglare uši  
(ajustare balamale)

(TR) Kapıların ayarlanması  
(menteşelerin seviye ayarı)

(RU) Регулировка дверей  
(регулировка шарнира)

