

60 cm

Built-in Combine Set

MODEL / SMF-CS 3024

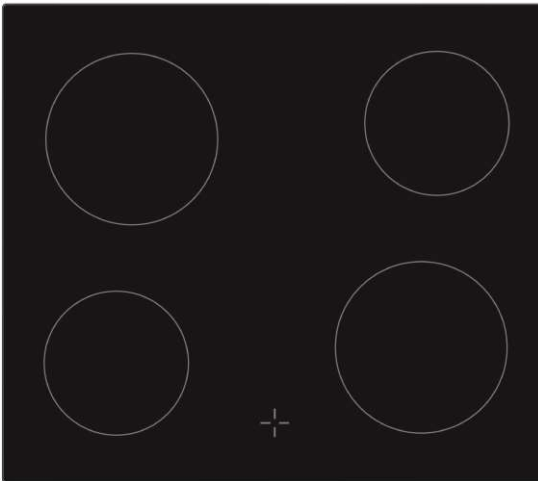

FEATURES

Oven:

5 Functions
Oven light
Side Wire Racks System
Double glazed door

Hob :

Vitroceran Built-in hob
Front Control
Touch Control
Safety Lock
Automatic Safety Cut Out
Residual Heat Indicators
9 power levels
4 Hi-lighted Zones:
2 x Ø140 mm :1200 W
2 x Ø180 mm :1800 W

SAFETY

Oven:

Safety Cut-off bimetal thermostat

Hob :

Safety Lock
Automatic Safety Cut Out

WARRANTY

2 years

ACCESSORIES

1 Baking Tray
1 Wire Shelf

REQUIREMENTS

Hard wired
Should be installed by a qualified electrician.

EAN

8699272030574

ENERGY RATING

A Energy

CAPACITY

62 lt
Shelf positions:4

CLEANING

Easy detachable side wire racks
Easy to clean enameled cavity
Easy detachable inner glass door

5 COOKING FUNCTIONS

High Grill
Low Grill
Full Oven
Bottom Heating Element

PRODUCT DESCRIPTION

Oven:

Shrink+Styrofoam
Packaged Dimensions
620 x 640 x 650mm (W,D,H)
Product Dimensions
595 x 565 x 595mm (W,D,H)
Weight
Net:31,8kg
Gross:33,3kg

Hob :

Packaged (w,d,h)
Carton Plate
630 x 570 x 100 mm
Physical (w,d)
490 x 560 mm
Weight
Net:7,8kg
Gross:8,7kg

INSTALLATION

See the diagram below

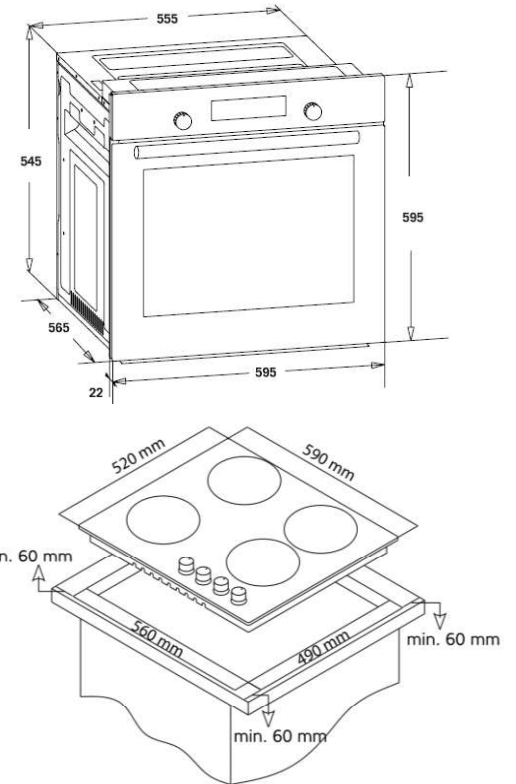

simfer