



Mcombo®

Electric Toilet Lifts

6360-M212W



Distributor and Dealer:

This manual must be given to the user of the product.

User:

Before using your toilet lift read this manual and save for future reference.

NEWACME LLC
2808 Vail Ave Commerce
CA, 90040
323-597-1109
Email: sales@mcombo.com

TABLE OF CONTENTS

SECTION 1 GENERAL INFORMATION

OPERATING INSTRUCTION..... 3
INTRODUCTION..... 3
DISCLAIMER..... 3
WATNING..... 4
SYMBOLS AND LABEL LOCATION..... 5
PRODUCT OVERVIEW..... 6

SECTION 2 INSTALLATION AND ASSEMBLY

UNPACKING YOUR TOILET LIFT..... 7
UNIT ASSEMBLY..... 8
INSTALLING THE TOILET LIFT AROUND TOILET..... 11

SECTION 3 USING YOUR TOILET LIFT

INSTRUCTIONS FOR INDIVIDUAL USERS..... 13
INSTRUCTIONS FOR CAREGIVERS..... 15
CLEANING GUIDELINES..... 16

SECTION 4 ADDITIONAL INFORMATION

TROUBLESHOOTING..... 17
LIMITED WARRANTY..... 18
RETURN POLICY..... 18

SECTION 1 GENERAL INFORMATION

OPERATING INSTRUCTION

Please ensure both yourself and any helpers read the following instructions carefully before using your toilet lift. These operating instructions should be retained for future reference.

This toilet lift is designed and manufactured to assist individuals in getting on and off the toilet. It should not be used for any other purpose. Do not use it in combination with other lifting or moving devices.

INTRODUCTION

- Thank you for purchasing the Mcombo Electric Toilet Lift. Our toilet lift corporation is striving to reduce toileting-related patient falls and caregiver injuries as well as restore dignity to individuals challenged by the ADL of toileting.
- Please read these instructions entirely before installing or using your new toilet lift.
- After installation, it is important that you cycle - fully raise and lower - 3-4 times (without sitting on or adding any weight to the seat) to become familiar with its functionality.
- Actuator images shown are for illustrative purposes only; actual style may vary.

DISCLAIMER

We ask that you read this manual completely before assembling and operating your new Mcombo Toilet Lift. We are not and cannot be held responsible for any damage or injury incurred due to improper or unsafe use of the Mcombo Toilet Lift. We specifically disclaims responsibility for any bodily injury or property damage that may occur during any use that does not comply with applicable federal, state, or local laws or ordinances.

WARNING!

- Rated load: 330 lbs. Never exceed rated load.
- Please keep the original packaging after receiving the product
- Read and follow all instructions and warnings prior to assembly and use. Correct installation, proper use, following instructions and obeying warnings are necessary for safe operation. For additional information, or to obtain replacement copies of instructions or labels, call 323-597-1109 or email us sales@mcombo.com.
- Understand and learn the location and function of all the features before operating.
- For use with secure, properly mounted, floor mounted toilets only.
- Observe and avoid all pinch points and always keep hands above the seat when operating the toilet lift.
- Ensure that there is no interference within the toilet lift's range of movement.
- To help prevent slipping, it is important to wear footwear with firm, non-skid soles when using the toilet lift.
- Remove loose rugs and make sure that the area around the toilet lift is free of all obstructions and moisture.
- The toilet lift is strictly an assist lift. The user must have dexterity, strength, and balance in order to use the toilet lift safely. Nonresponsive or combative users may not be suitable for toilet lift usage.
- Do not use toilet lift for anything other than its intended purpose.
- This product is intended for use by ambulatory and semi ambulatory patients capable of bearing their individual body weight unassisted.
- If any part of the toilet lift is damaged, loose, or faulty, do not use until repairs can be made by a qualified technician.
- Do not route power cords so that they may become damaged, pinched, create trip hazards, or create other safety concerns.
- Check all toilet lift electrical cords frequently to ensure they are not worn or damaged.
- Stop using toilet lift immediately and contact your Certified Dealer or Technician if any defect is suspected.
- To reduce risk of shock and or electrical hazard, keep all electrical components free from moisture at all times and only use properly grounded electrical equipment, outlets, and plugs.
- The toilet lift is not a toy; never play on or near the lift.
- Do not continually operate the hoist functions. The system is not designed as an exercise machine and continuous operation will cause damage the actuator.
- Do not pull on, or otherwise exert excessive force on, the handset cable as this may break off the wires inside the cable and prevent some or all toilet lift operations.
- Warning indicates a potentially hazardous situation which, if not avoided, could result in death or serious injury.

SYMBOLS

 The WARNING symbol indicates a potentially hazardous condition/situation. The safety warnings throughout this manual, and on your equipment, if any, are for the protection of people and property. Failure by any operator to abide by safety warnings will result in a waiver of all liabilities, loss of your warranty, and could result in equipment damage and or failure, property damage, risk of serious bodily injury, and or death. The symbol may appear in various colors and in conjunction with other symbols.

IN DEPENDENCE LABEL LOCATIONS

Our toilet lift has placed warning tags and labels on the product. Do not remove these labels



Read and follow the information in the owner's manual



320 Lbs Weight Capacity



Pinch/Crush Points Hazard! Do not place objects or appendages in the path of moving parts



Electrical Hazard



Do not place objects under the power lift recliner. Make sure the area is clear of obstructions



Indoors Use Only.

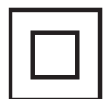

Class II Equipment



Degree of protection against electric shock.



Stepping on is forbidden, there is danger of tipping over

PRODUCT OVERVIEW

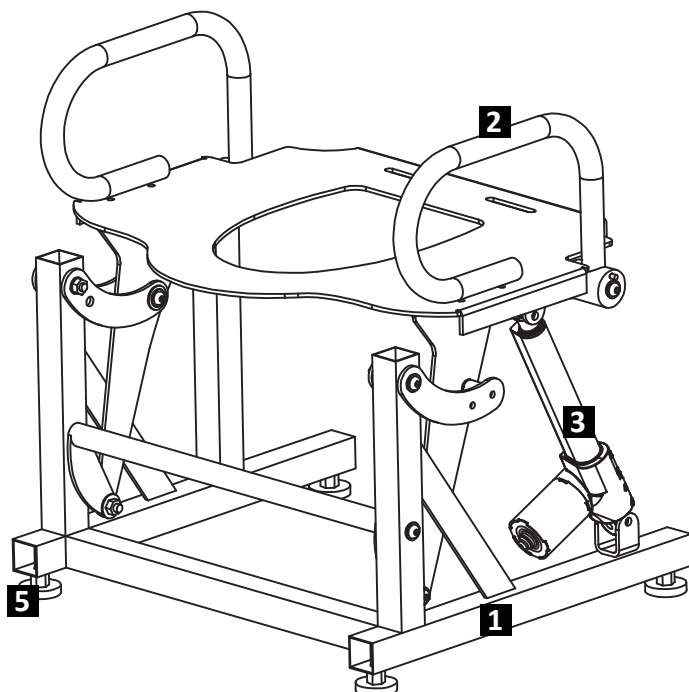

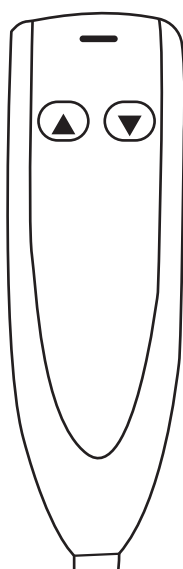

1. Structure – Provides the vertical, horizontal, and rotational lift necessary to support the sit-to-stand process.
2. Handle Bar – Handle bars for patient to place their hands on during the sit-to-stand process.
3. Linear Actuator – Linear actuator is mounted to the frame to move the device up and down.
4. Hand Pendant – See below.
5. Leveling Feet – The toilet lift is provided with leveling feet so the unit can be installed on moderately uneven floors.

Hand Pendant



The hand pendant is for a caregiver or patient to use.
The buttons on the hand pendant perform the following functions:

 Up Button: Raises the toilet lift

 Down Button: Lowers the toilet lift

SECTION 2 INSTALLATION AND ASSEMBLY

UNPACKING YOUR TOILET LIFT

Warning! Check all parts for shipping damage before using. In case of damage, do not use the equipment. Contact us at 323-597-1109 or email: sales@mcombo.com for further instructions.

Inspection of the Box Contents

Your toilet lift comes in one box.

Box 1: The box contains:

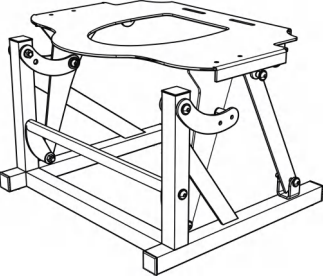
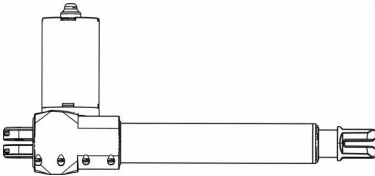
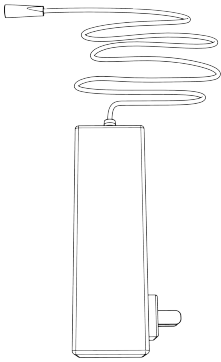
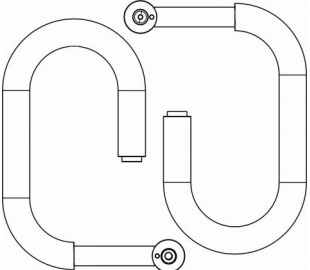
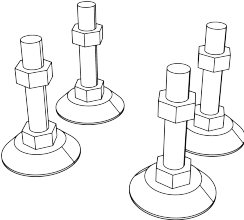
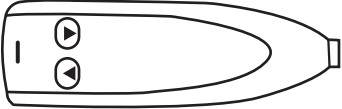
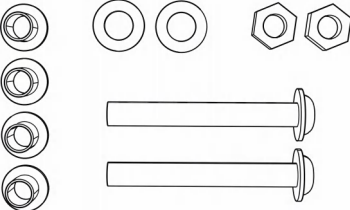
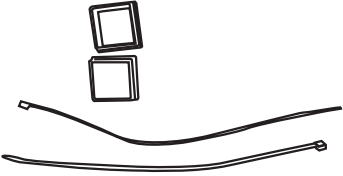
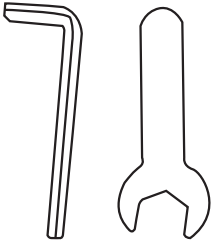
<p>A</p>  <p>Base</p>	<p>B</p>  <p>Lift actuator</p>	<p>C</p>  <p>Power supply</p>
<p>D</p>  <p>Handle bars</p>	<p>E</p>  <p>Leveling feet</p>	<p>F</p>  <p>Hand remote</p>
<p>G</p>  <p>Armrest mounting screws</p>	<p>H</p>  <p>Spare parts (2*Cable ties, 2*Base plastic covers)</p>	<p>I</p>  <p>Wrench</p>

UNIT ASSEMBLY

Unpacking

1. Carefully unpack all items and lay out contents for inspection. Remove any packaging tape or supplies.

2. Check contents against parts list. If anything is missing contact us at 323-597-1109 or email: sales@mcombo.com

Assembly of Toilet lift

1. Screw leveling feet into threaded hole on bottom of the base.

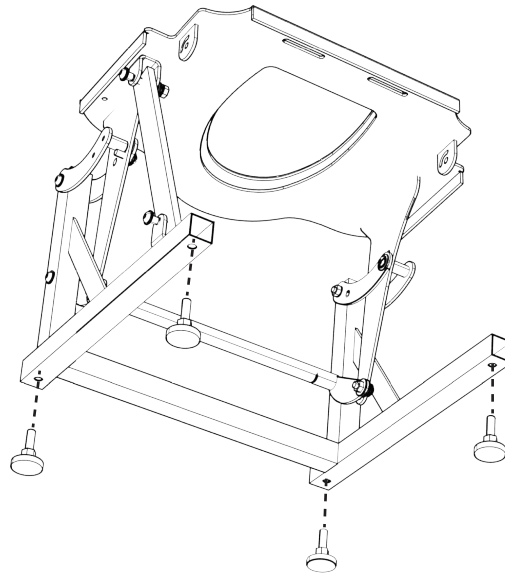

2. Pull out the bolts at both ends, then remove the iron piece, and install the pneumatic rod.

(**Note:** The bolt wire is relatively tight, please use gloves to pull out for safety)

- ① Put on gloves, break the two bolt wires and pull them out, then pull out the two bolts and remove the iron pieces.

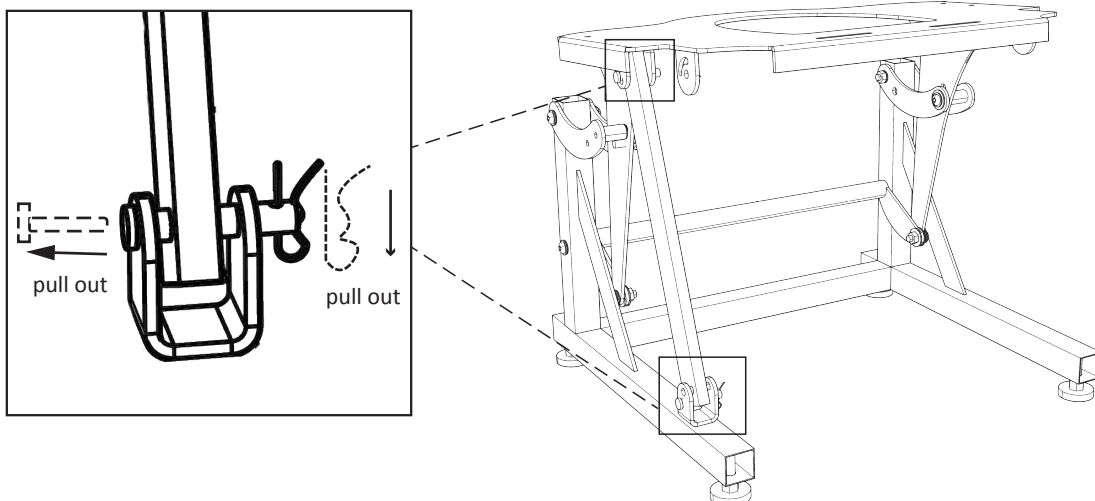

- ② Take out the lift actuator and place it to the position of the iron sheet just now, and align the screw holes on the upper and lower ends

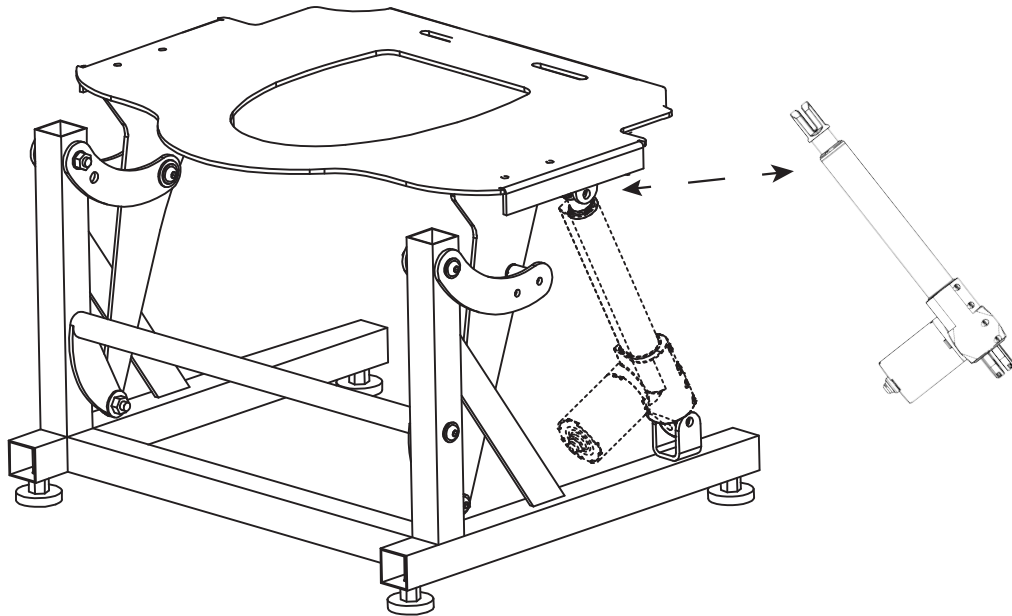

- ③ Insert the bolt just now, and then fix it with the bolt wires that were removed

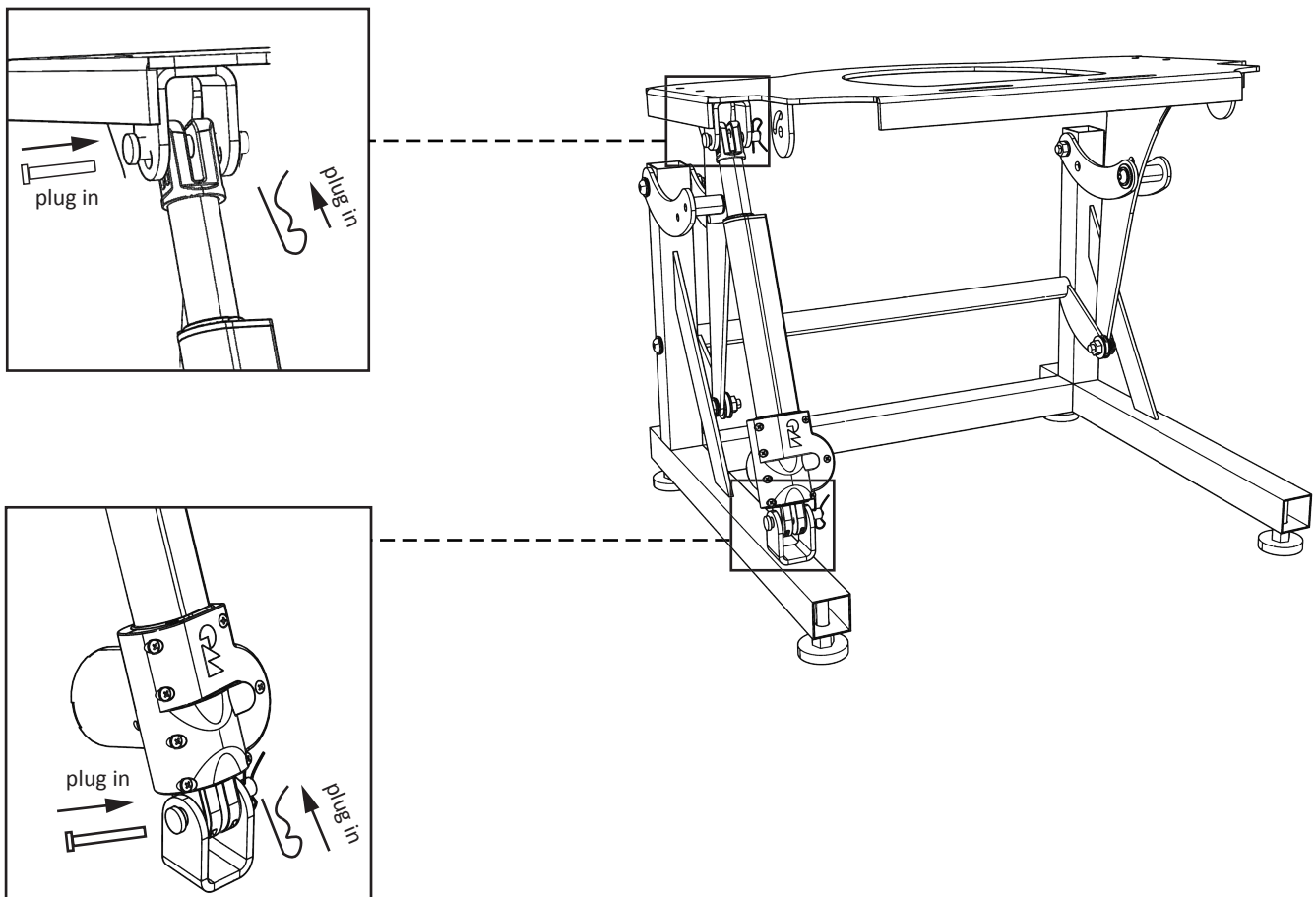

3. Connect Power supply and hand remote to lift actuator

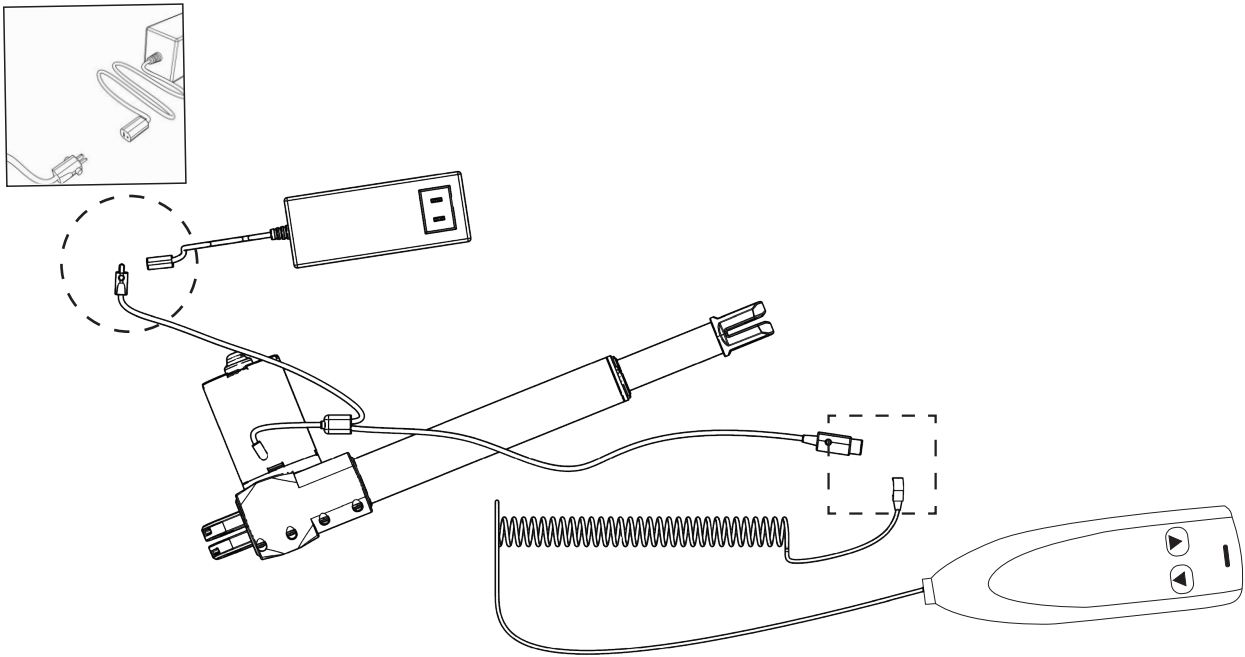

4. Install handle bars. (**Note:** Please install the sleeve on the hole of the armrest first, and then lock the screw)

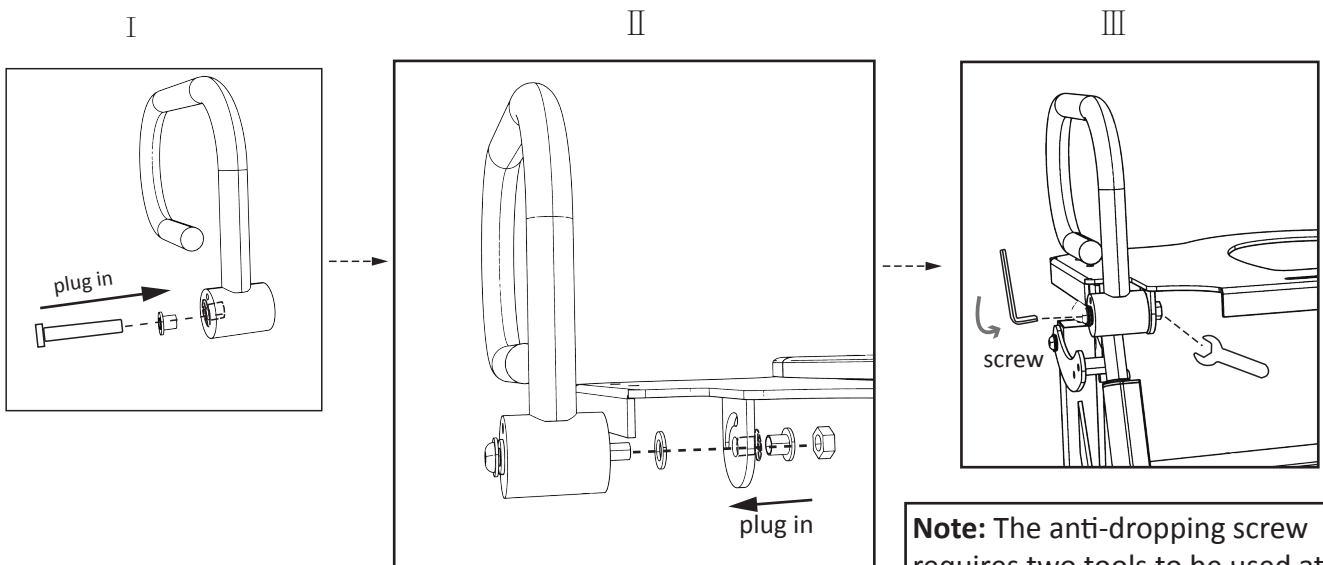

Note: The anti-dropping screw requires two tools to be used at the same time and requires a lot of force when strengthening.

5. Plug power supply into a 110V outlet and cycle the unit to the highest position.

Note: If unit doesn't cycle when plugged into a 110V outlet, contact us at 323-597-1109 or email: sales@mcombo.com

INSTALLING THE TOILET LIFT AROUND TOILET

⚠ Caution: Make sure the existing toilet seat is removed from the toilet.

1. Attach toilet seat to the unit. Make sure toilet seat is aligned to top plate. Then slide the toilet lift around the toilet so the unit is centered left-to-right and front-to-back.

1

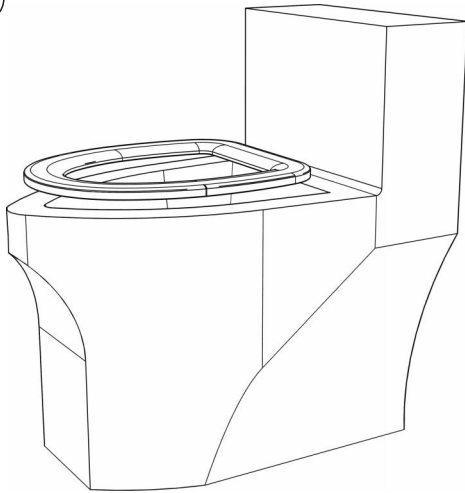

2

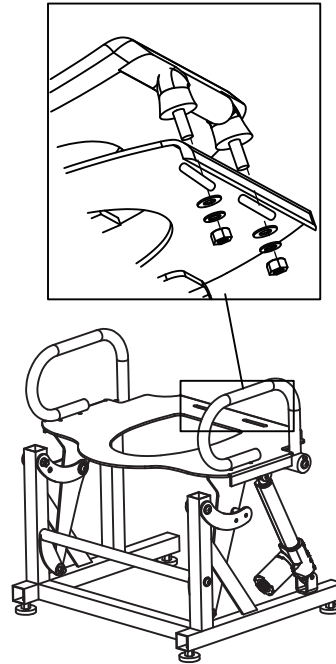

⚠ Caution: Make sure the back of the seat does not interfere with the back of the toilet

2. Test the movement up and down making sure there are no interference issues. if you need additional assistance with this step.

3

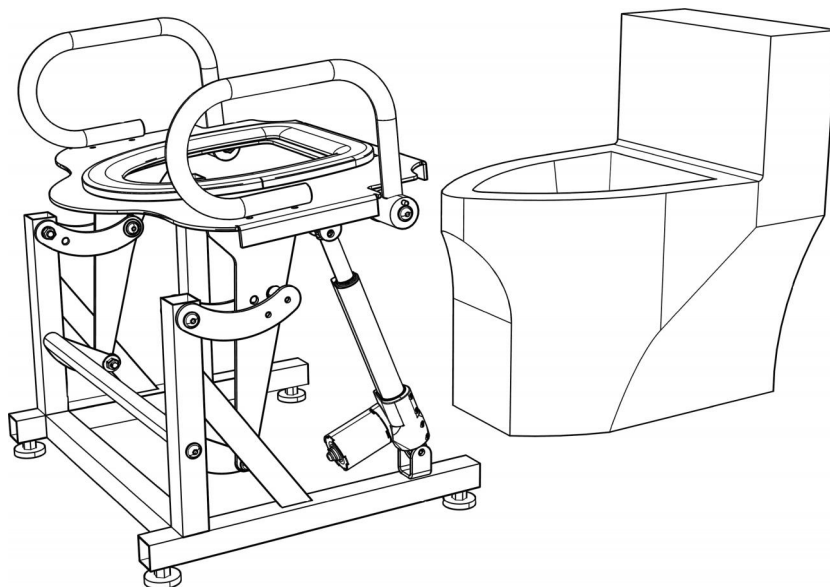

⚠ Caution: The bottom of the toilet lift should not be closer than 1 inch to the top of the toilet rim. To adjust the height, use leveling feet.

3. Use the leveling feet as needed to adjust the proper height of the unit over the toilet.

4

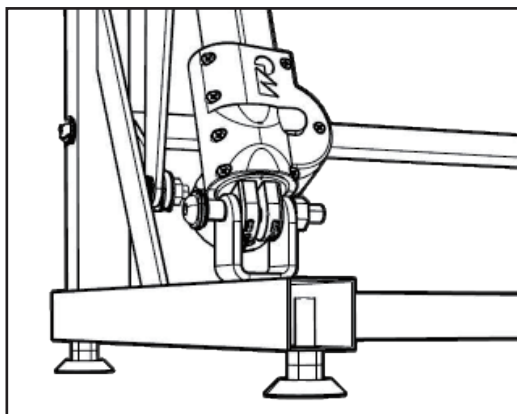

Lowest

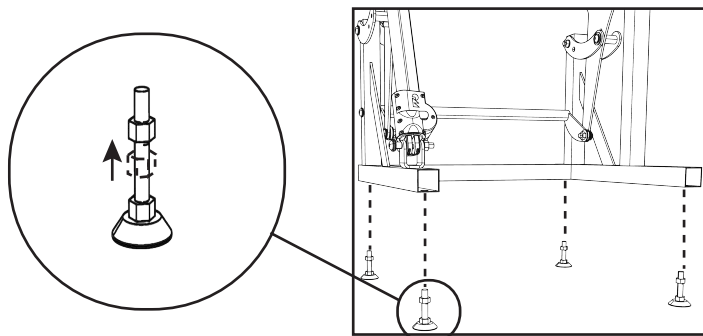

Adjust Height

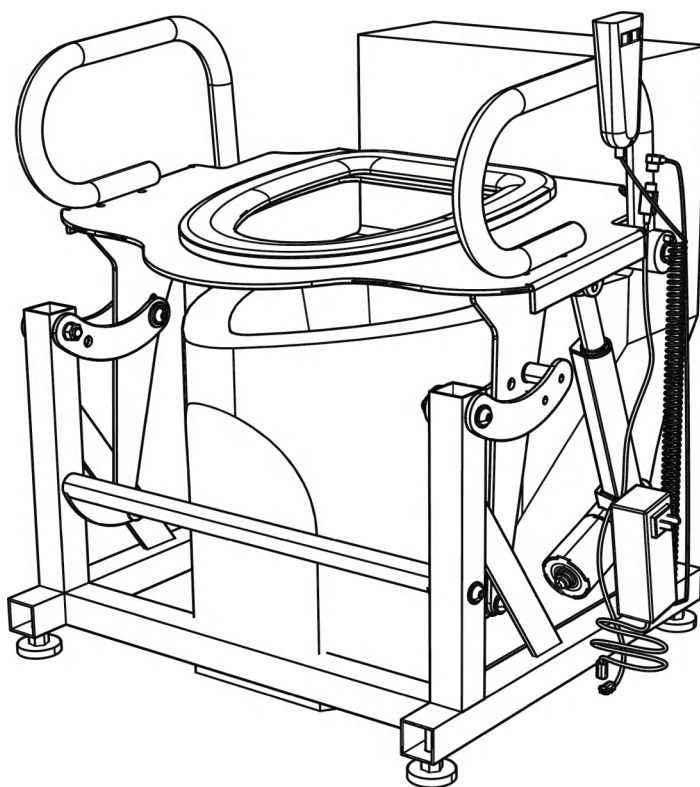

SECTION 3 USING YOUR TOILET LIFT

INSTRUCTIONS FOR INDIVIDUAL USERS

Do not attempt any transfer without approval of the patient's physician, nurse or medical assistant.

Thoroughly read the instructions in this Owner's Manual. Use common sense every time using the toilet lift. Special care must be taken with people with disabilities who cannot cooperate during the lift process.

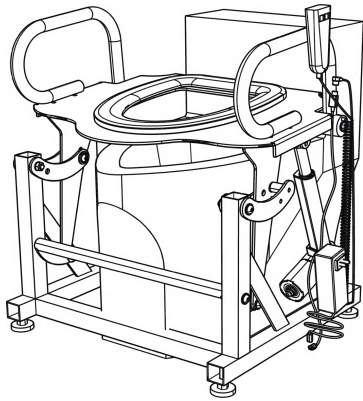

Figure 1

Make sure the Toilet lift is in the fully raised position or in the position most suitable to the user depending on the individual's size. For a wheelchair to toilet transfer, keep the lift in the down position.



Figure 2

Use the Up and Down buttons on the hand pendant to move the toilet lift to the desired position.

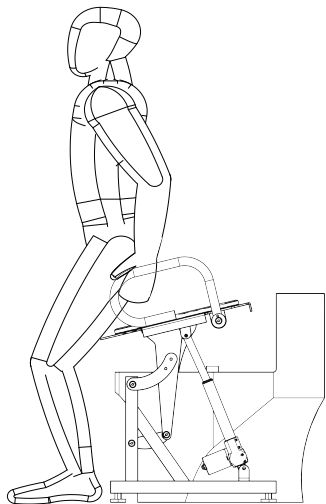

Figure 3

Stand facing away from the toilet lift the same way you would stand before sitting on a regular toilet. Place your hands on the handle bars. Make sure you are in a comfortable position.

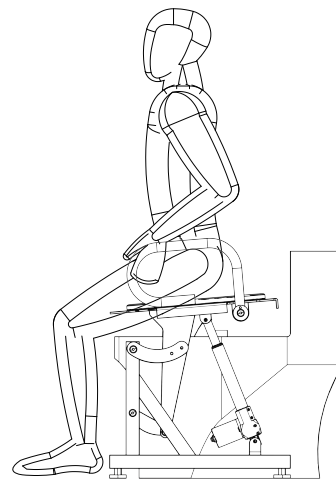

Figure 4

Slowly, lower yourself onto the seat, using your arms and handle bars for support.



Figure 5

Press the Down button on the hand pendant. You must keep the button depressed for the toilet lift to continue moving to the seated position. If at any time you feel uncomfortable or unstable, remove your thumb from the button to stop the movement.

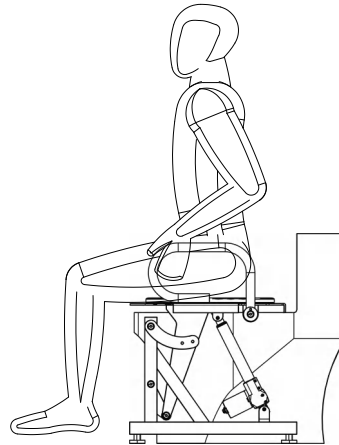

Figure 6

For your safety, once you are done toileting, stay seated while completing all your hygiene activities.

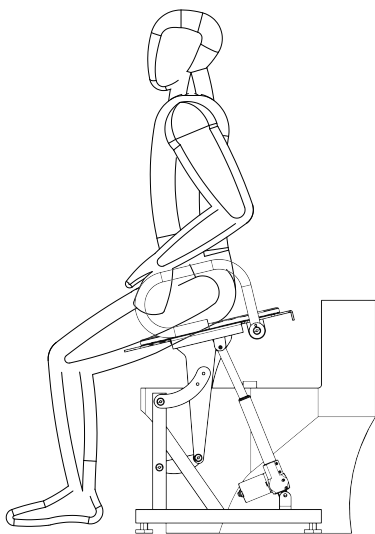

Figure 7

When you are ready to get up, plant your feet firmly on the ground before pressing the Up button on the hand pendant. If your feet are not firmly on the ground, slide forward until your feet touch the ground. Keep your arms on the handle bars, and use your hands to steady yourself when rising to the standing position.

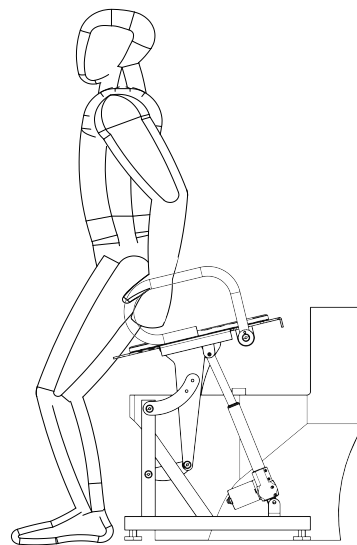

Figure 8

When you are ready to get up, plant your feet firmly on the ground before pressing the Up button on the hand pendant. If your feet are not firmly on the ground, slide forward until your feet touch the ground. Keep your arms on the handle bars, and use your hands to steady yourself when rising to the standing position.

INSTRUCTIONS FOR CAREGIVERS

Caregivers should follow the Instructions for Individual Users, with the following additions.

1. Move the toilet lift to the fully raised position (or to the most comfortable position for the patient).
2. With the hand pendant in one hand, stabilize the patient in front of the toilet lift. Place your free arm securely under the patient's arm between the patient's arm and body. Wrap your arm around the patient's back.
3. Assist the patient to a stable sitting position on the toilet lift.
4. Use one hand to steady the patient, and use the other hand to use the hand pendant to lower the toilet lift to the fully lowered position.
5. Assist the patient with toileting as required.
6. As much as possible, all hygiene activities should occur with the patient in the seated position.
7. Before raising the toilet lift to the fully raised position, make sure the patient has both feet firmly on the floor. If not, help the patient move forward until the patient is in the correct position with both feet on the floor.
8. Press the button on the hand pendant to begin raising the toilet lift, lifting the patient to the standing position. Make sure the patient's arms are securely placed on the handle bars.
9. Continue raising the seat until you believe the patient is ready to complete the transfer process. Little or no effort should be needed to transfer the patient to the standing position.
10. Lower the toilet seat to the fully lowered position after the transfer.

Caution: Do not operate lift with the toilet seat in the up position.

Warning! Non-responsive or combative patients may not be suited for toilet lift.

CLEANING GUIDELINES

Proper cleaning and inspection are essential to keep the toilet lift operating at maximum efficiency and providing the best possible safety for each user of this product. If the toilet lift is not cleaned on a regular basis, the top plate of the unit could prematurely rust due to the highly corrosive nature of urine. The toilet lift unit must be maintained and cleaned accordingly.

Do not use abrasive cleaners, brushes, or scouring pads to clean the toilet lift unit.

For cleaning:

1. First remove the toilet lift unit from around the toilet as follows:
 - Remove 110V plug from the wall
 - Slide toilet lift unit away from toilet
2. Clean the toilet lift
 - Wipe down all metal surfaces (top plate, linkage bars, and frame) using a soft cloth or non-abrasive sponge with a mild cleanser such as, soap and water or other mild household cleaners to remove any contaminants.
 - Wipe dry all the cleaned surfaces of the unit using a dry soft cloth.
 - Keep the unit in the lowered position when cleaning the actuator, so that the actuator cannot be degreased causing premature failure. Clean the actuator as suggested above.
3. After cleaning the toilet lift unit and the toilet, replace the toilet lift unit as follows:
 - Return unit around toilet
 - Plug unit back into 110V wall socket
 - Use the hand pendant to check the alignment of the unit to the toilet. Refer to p. 13 for alignment instructions.

INSPECTIONS

Inspect the unit to make sure it is level to the floor. Check to make sure the unit is properly aligned to the toilet. Use the hand pendant to cycle the unit from the seated position to the standing position, making sure it is free from any obstructions.

Contact us with any questions or concerns you may have.

SHIPPING CONDITIONS EFFECT ON TOILET LIFT

If the box is exposed to weather, no hazards exist as a result of packaging failure due to excessive weather (i.e. being exposed to rain, snow or extreme humidity).

If packaging fails due to destructive forces, check all connections on the frame to make sure the product did not suffer any physical damage. Other than extreme cases, no structural damage, other than cosmetic, should occur if the packaging fails

SECTION 4 ADDITIONAL INFORMATION

TROUBLESHOOTING

The following troubleshooting FAQs should summarize what you need to know about your toilet lift.

If at any time you do not feel comfortable performing the troubleshooting steps listed in this manual, please contact the Mcombo Customer Service for service.

Please have the model number '6260-L212W', order ID, and nature of the problem when calling or emailing.

Questions	Action
What if my toilet lift does not operate at all?	<ul style="list-style-type: none">● Check all the electrical cords are not crimped or pinched. Make sure the electric cord or plug is not damaged.● Check the power supply to make sure the green LED power indicator light is on.● Make sure all the connections are secured; refer to the Assembly Instructions.
What if my toilet lift is wobbly?	<ul style="list-style-type: none">● Check the 4 leveling feet to make sure all the All feet are at the same height; refer to the Assembly Instructions.● Make sure the floor is flat and nothing is pressed.
What if my toilet lift makes a clicking noise?	<ul style="list-style-type: none">● Check the lift motor and make sure the end of lift motor at the center of pivot point.● Make sure the weight capacity of 320 lbs has not been exceeded.
IMPORTANT: If the lift recliner still does not operate properly, please contact the Mcombo® Customer Service for help and never attempt to make any repairs or adjustments yourself.	

LIMITED WARRANTY

For a period of 24 months from the date of shipment. Mcombo warrants the powder metal paint finish, the control box, hand pendant, batteries, and linear actuator for a 12 month period from the date of purchase. If within such warranty period any such product should be proven to be defective, such product shall be repaired or replaced, at Mcombo option.

This warranty does not include any labor or shipping charges incurred in replacement part installation or repair of any such product. Mcombo sole obligation and your exclusive remedy under this warranty shall be limited to such repair and/or replacement.

For warranty service, please contact Mcombo Corporation Customer Service.

Do not return products to Mcombo Corporation without our prior consent. C.O.D. shipments will be refused; please prepay shipping charges.

The warranty shall not apply to problems from normal wear or failure to adhere to the instructions in this manual.

The foregoing warranty is exclusive and in lieu of any other expressed warranties. Implied warranties, if any, including the implied warranties of merchant ability and fitness for particular purpose, shall not extend beyond the duration of the expressed warranty provided herein and the remedy for violations of any implied warranty shall be limited to repair or replacement of the defective product pursuant to the terms contained herein. Mcombo shall not be liable for any consequential or incidental damage whatsoever.

Lift Mechanism	1 Year
Metal Frame	1 Year
Electronic Parts	1 Year

RETURN POLICY

All of product come with a 30-day return/replace policy. During this time, we will cover the shipping cost of return and replacement for quality issue, through provide pre-paid return label or pick up service for customer's convenience.

Note: Please disassemble the toilet lift before you return it otherwise there will be a huge cost as oversized.



Mcombo®