

# RAVENNA 02

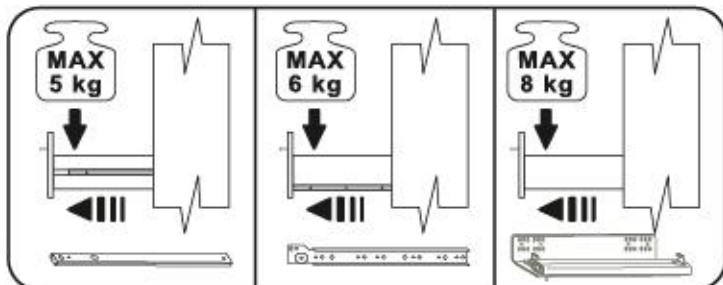

# RAVENNA 02

max.

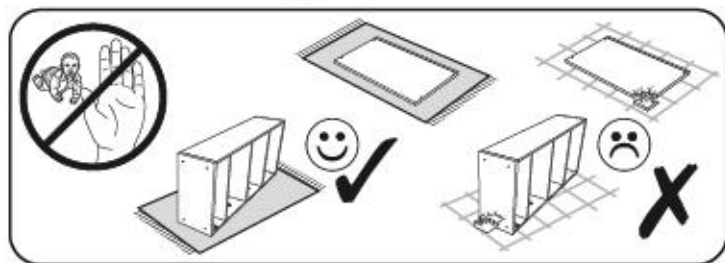
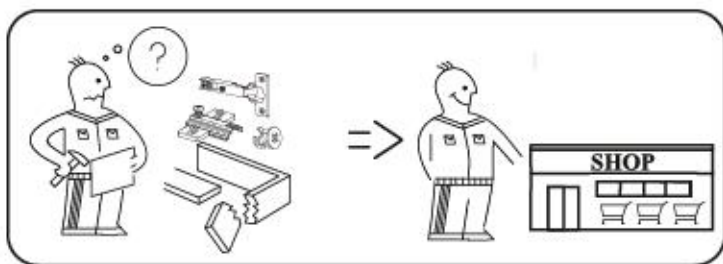
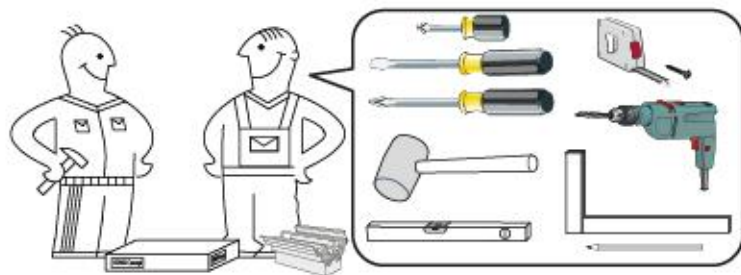
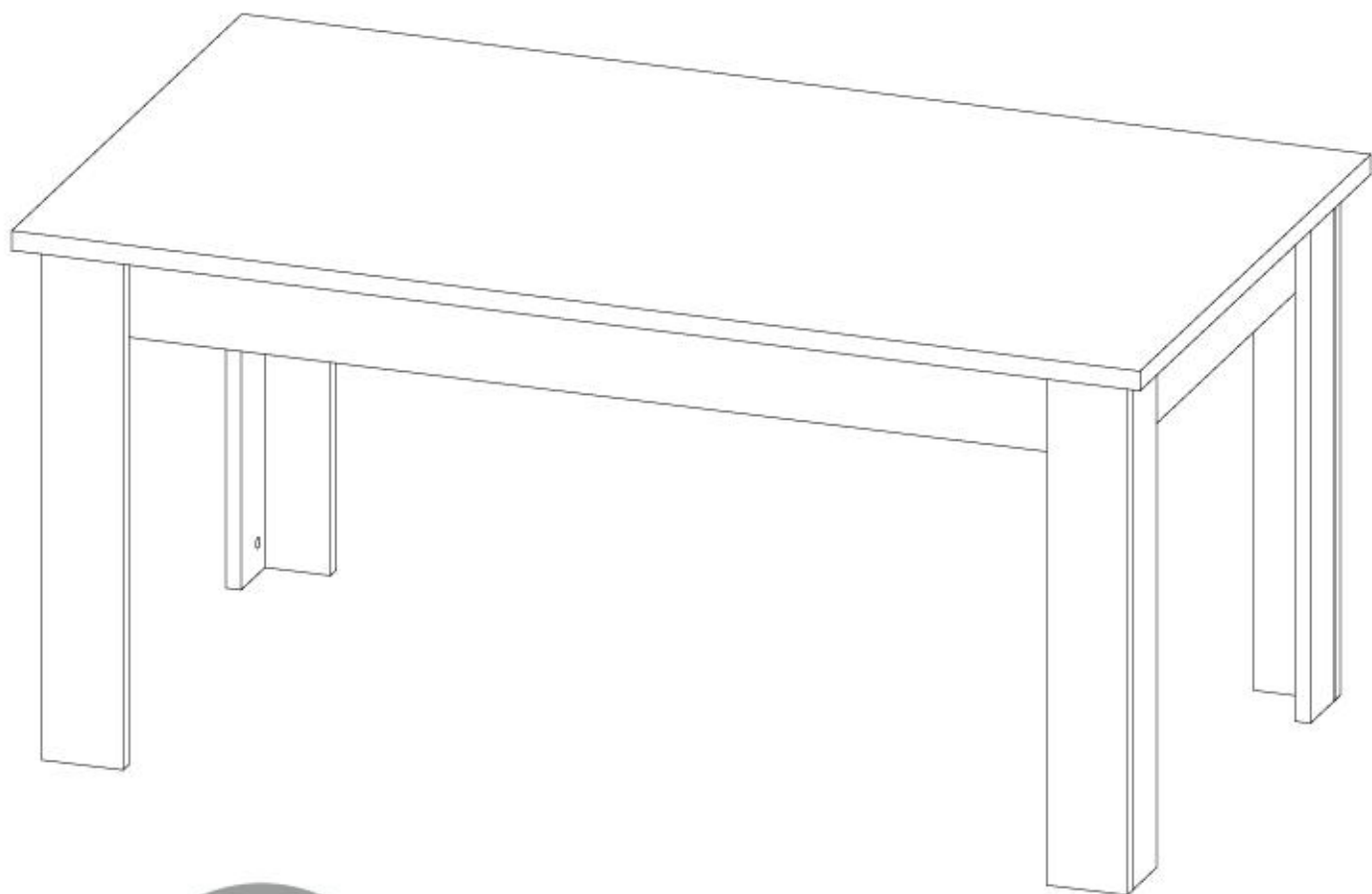

HC 1

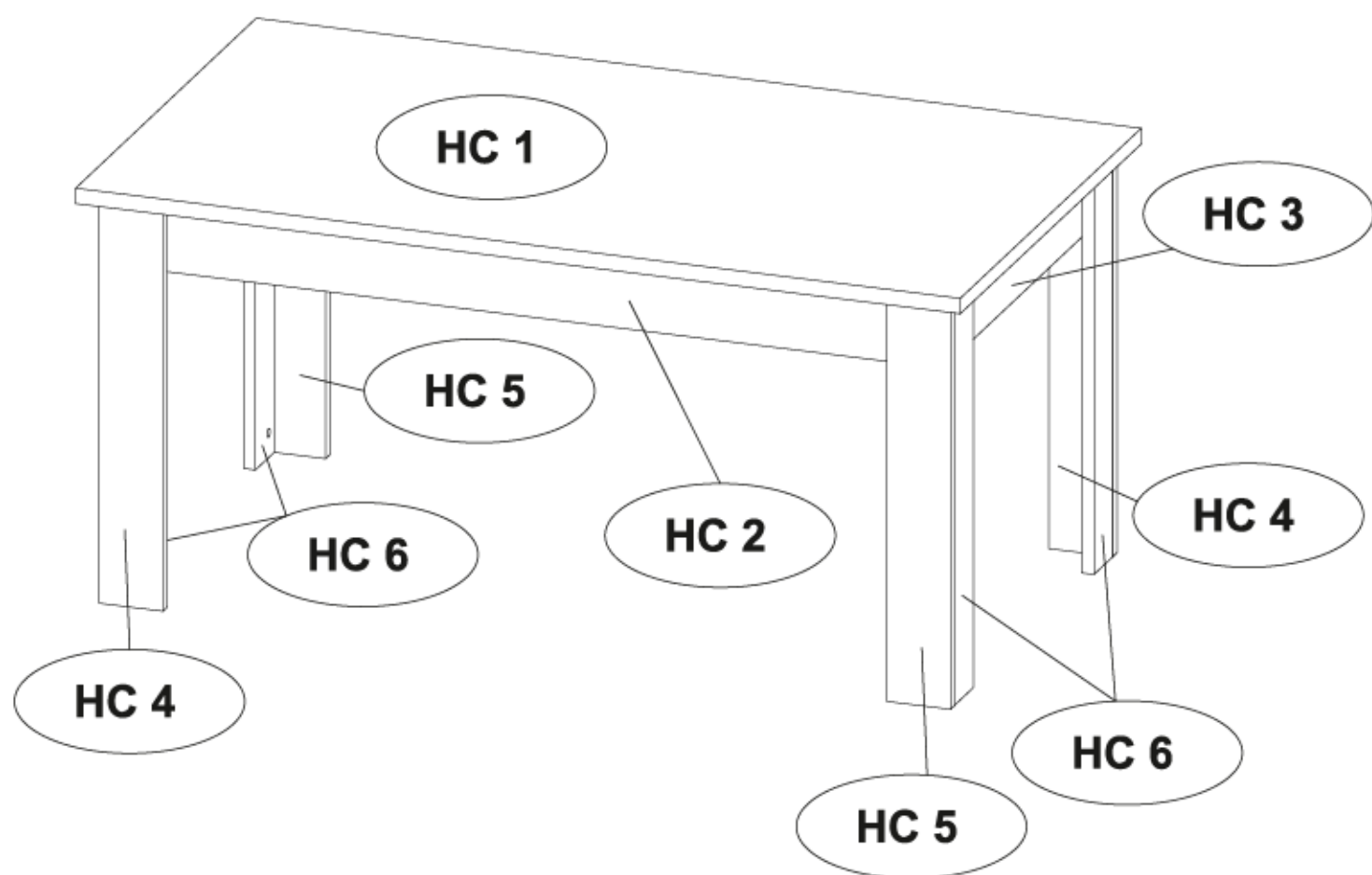

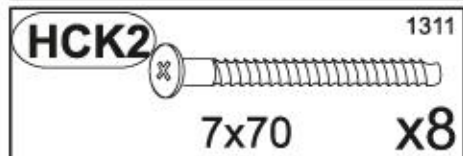
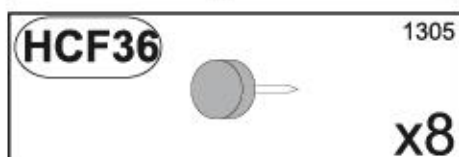
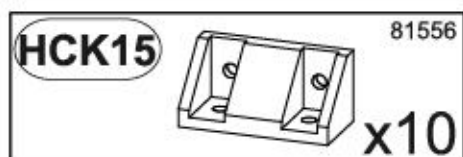
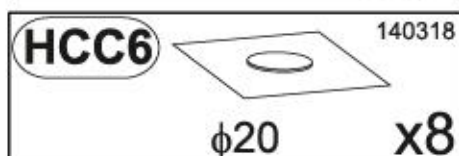
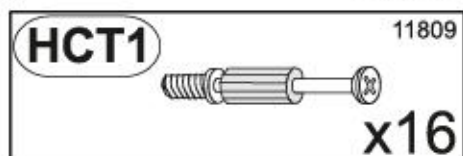
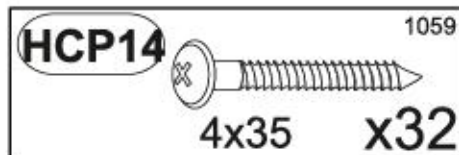
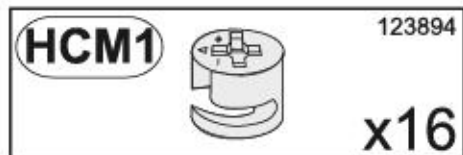
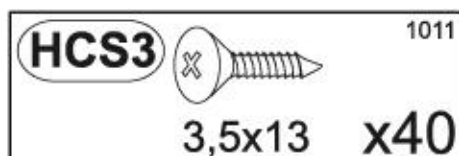
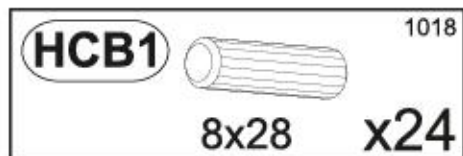

HC 1	x1	1596	896	28	1/1
HC 2	x2	1446	124	22	1/1
HC 3	x2	783	124	22	1/1
HC 4	x2	729	115	22	1/1
HC 5	x2	729	115	22	1/1
HC 6	x4	729	93	22	1/1

# RAVENNA 02



1

HCB1		1018
	8x28	x24
HCM1		123894
		x16
HCT1		11809
		x12

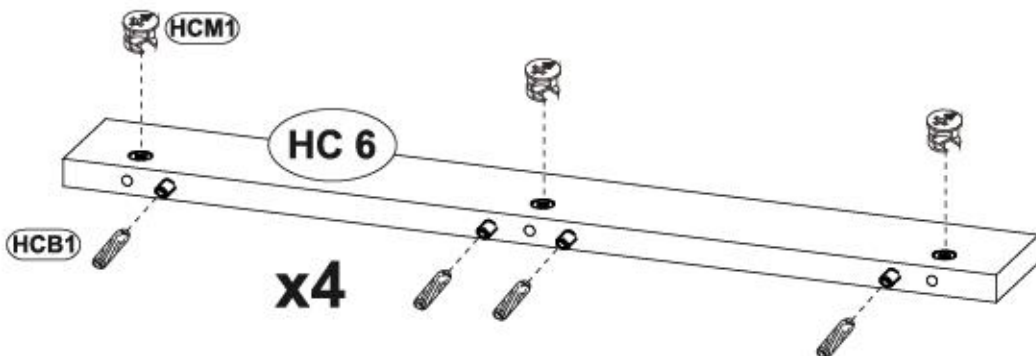
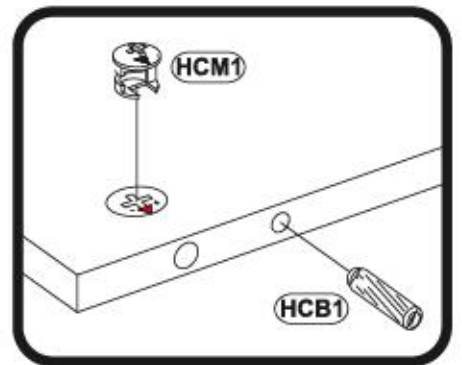
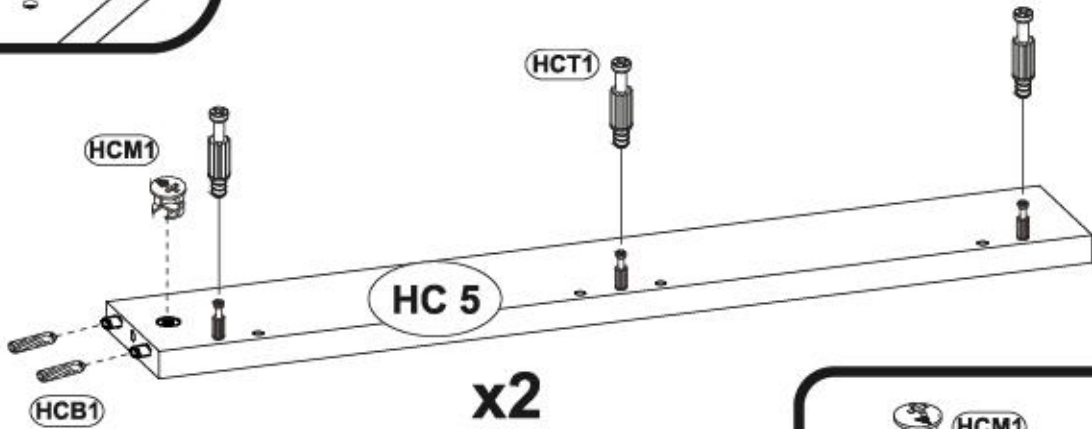
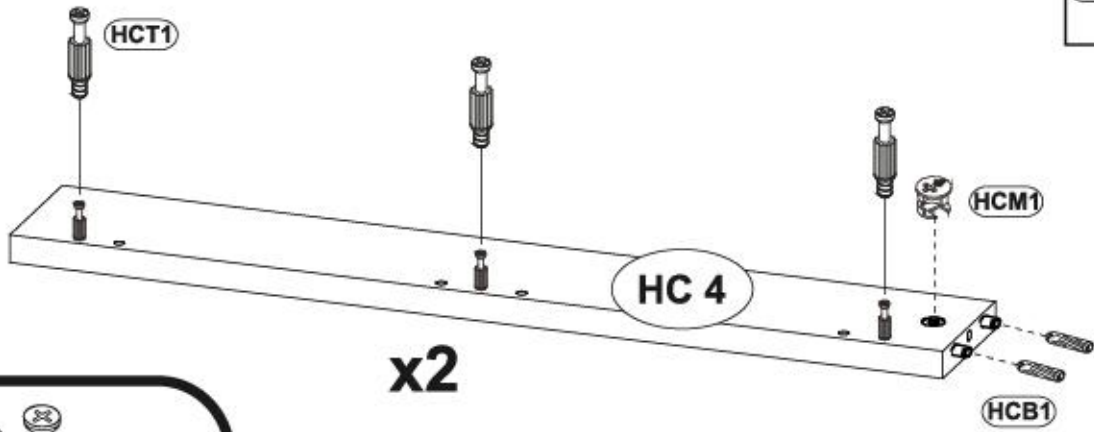

2

x2

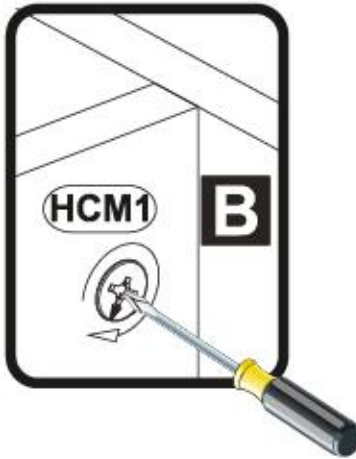
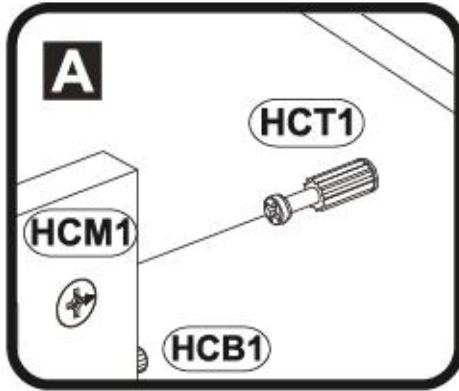
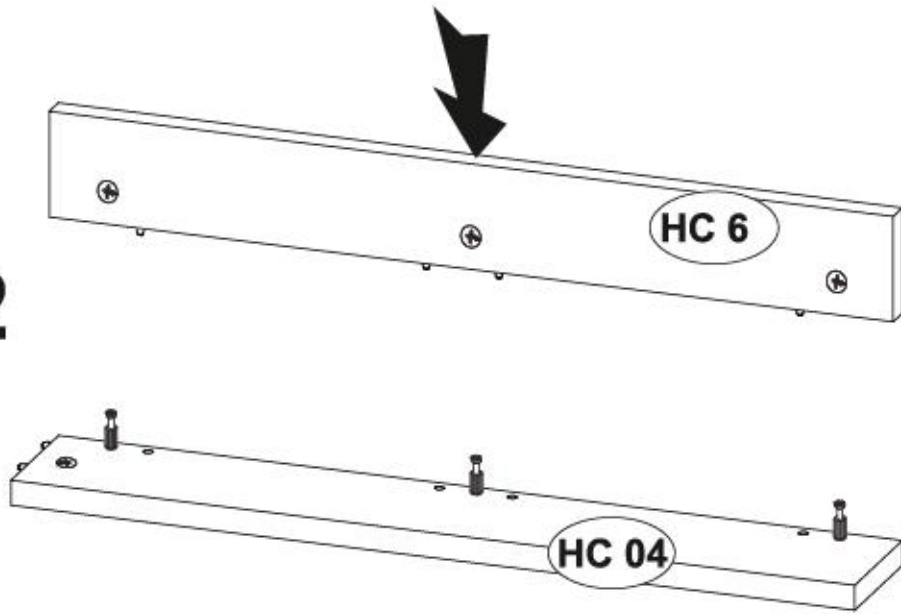

x2

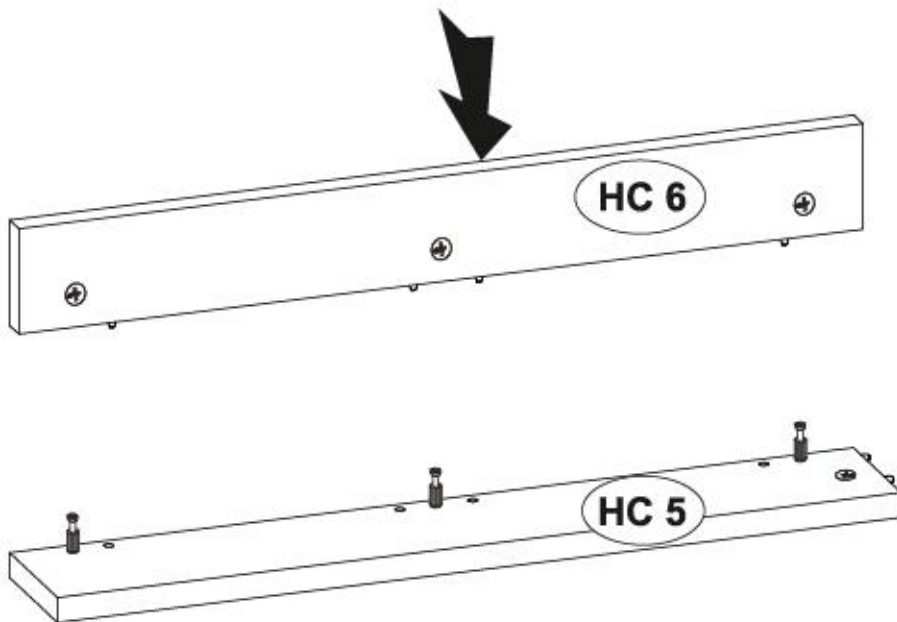

3

HCT1	11809		x4
HCK15	81569		x10
HCS3	1011		x20

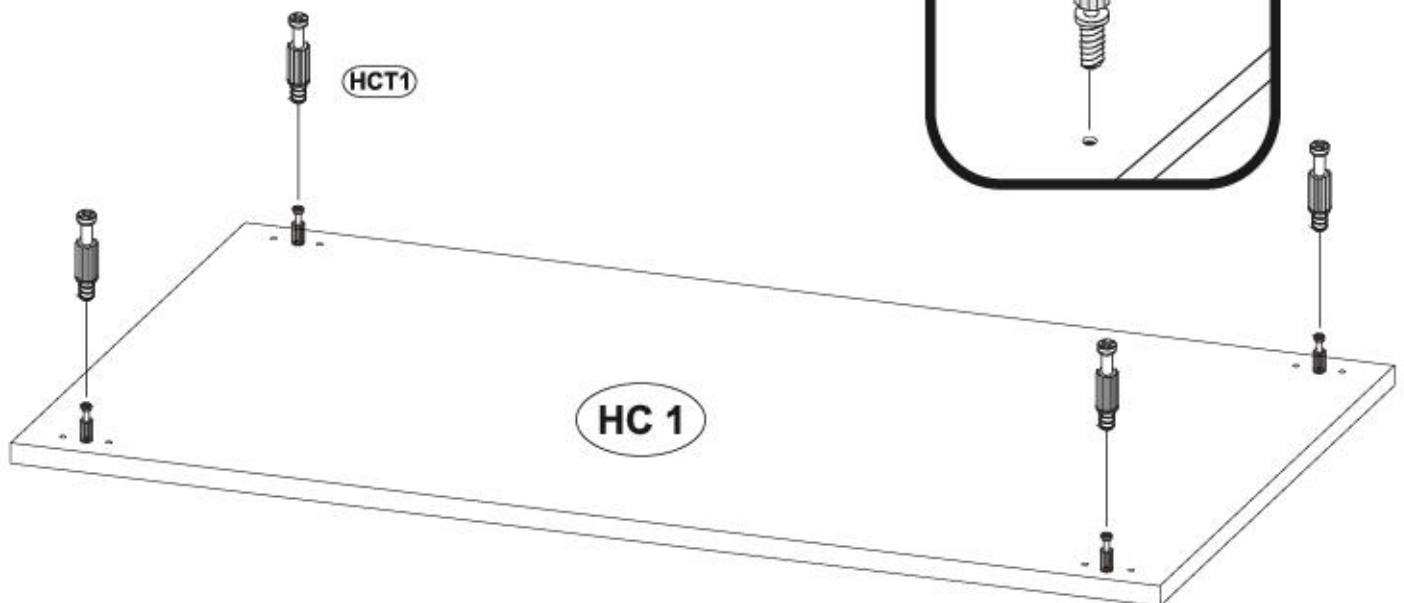
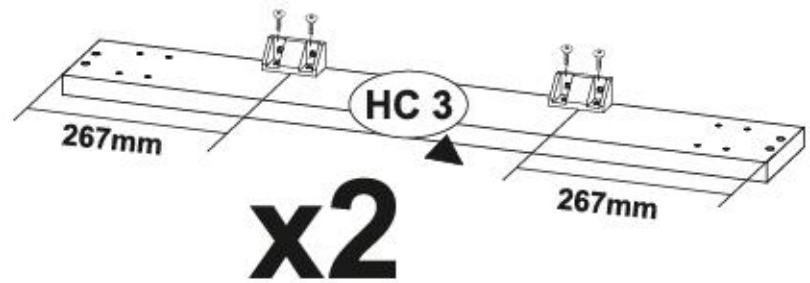
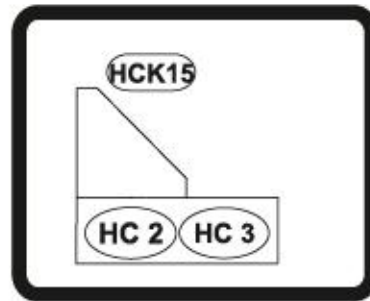
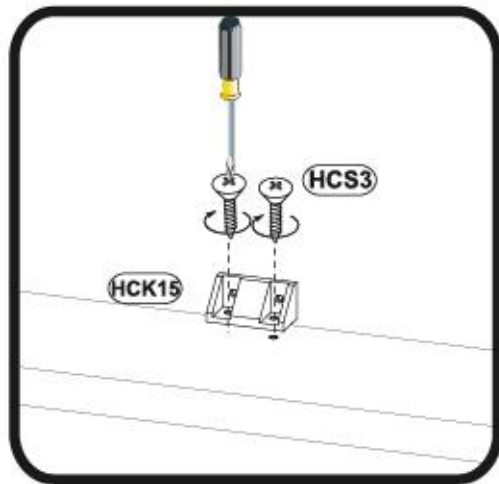
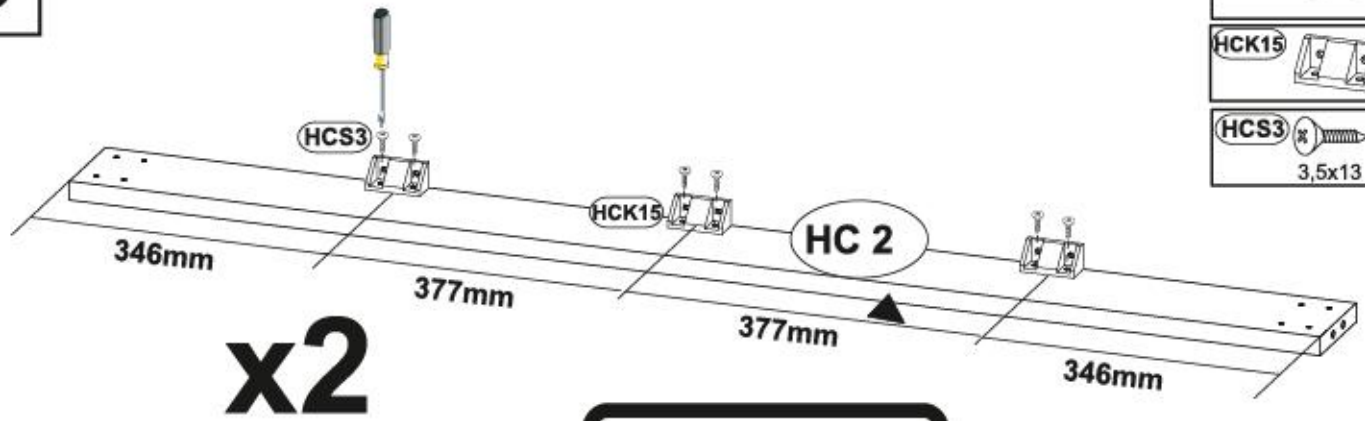

4



HCK2 13111  
7x70 X8

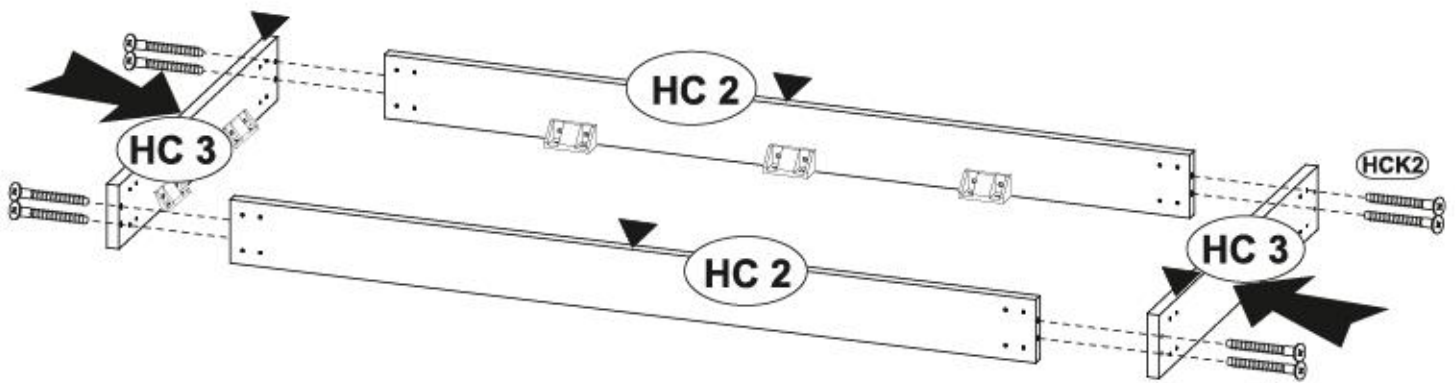
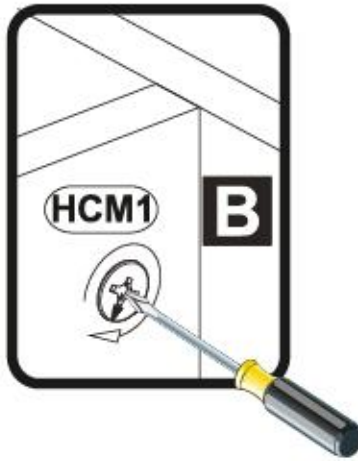
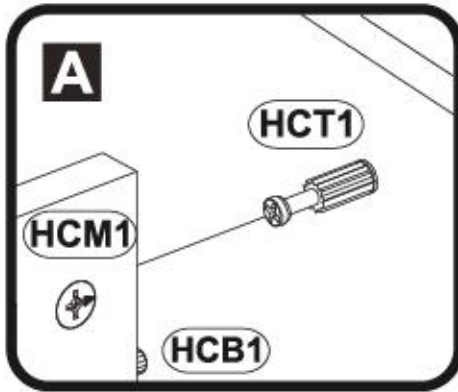
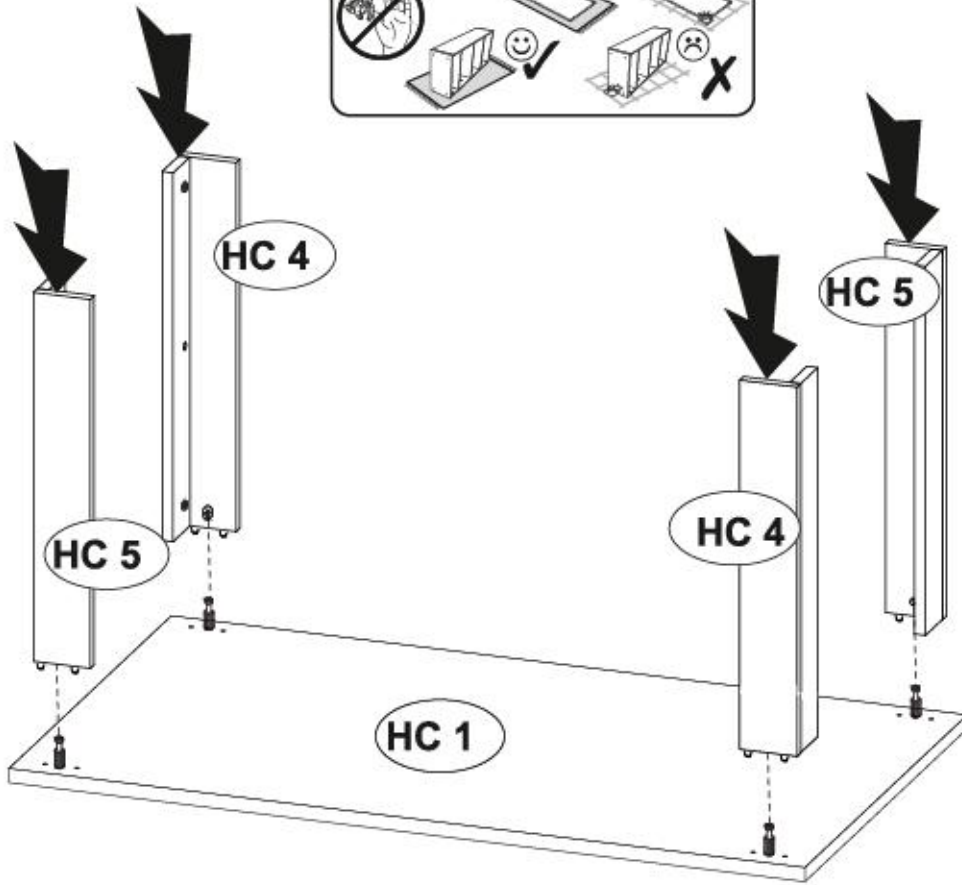



5



<b>HCS3</b> 1011		3,5x13	x20
<b>HCP14</b> 1059		4x35	x32
<b>HCC6</b> 140310		φ20	x8
<b>HCF36</b> 1956			x8

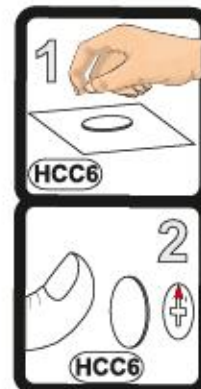
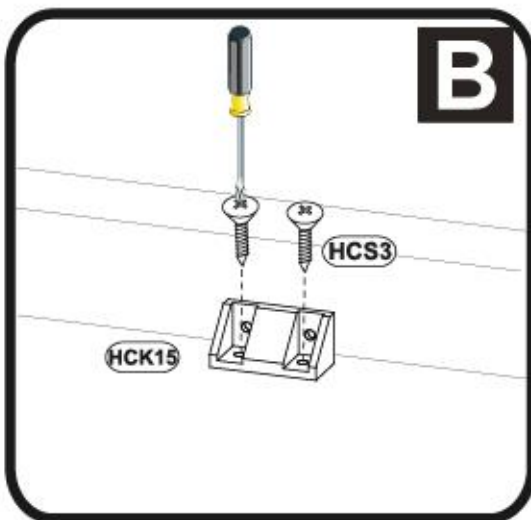
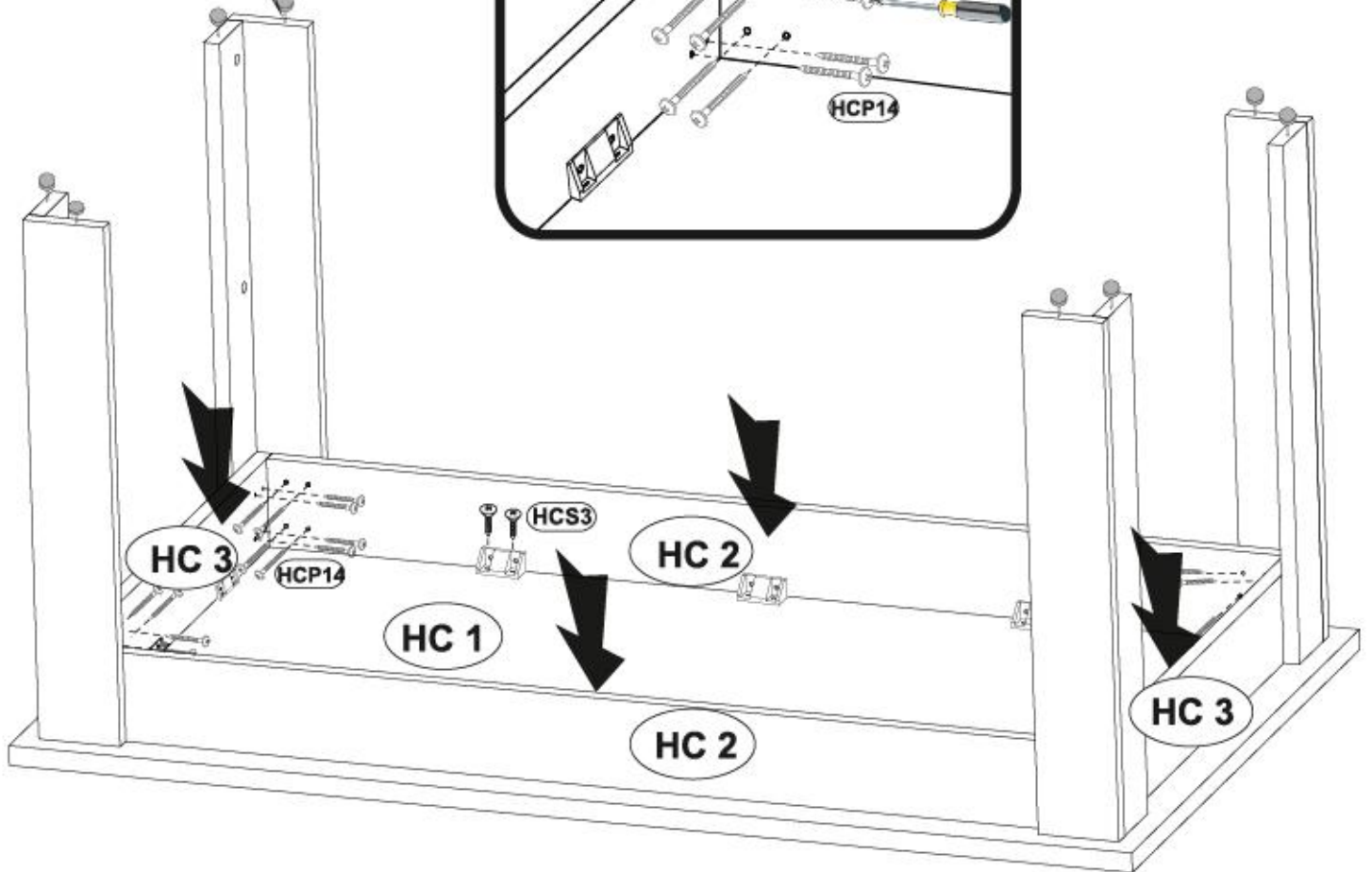
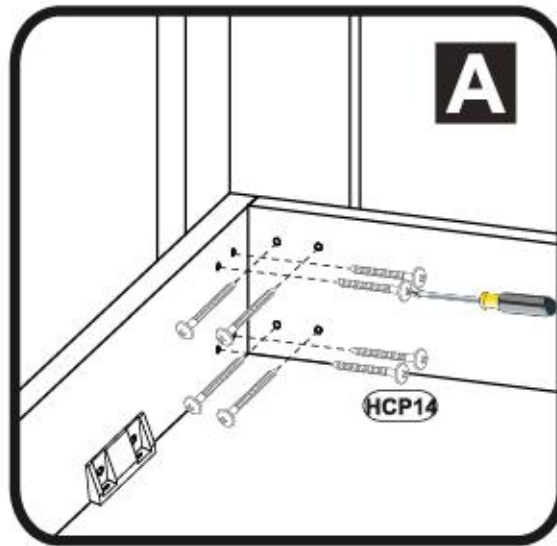



# RAVENNA 02

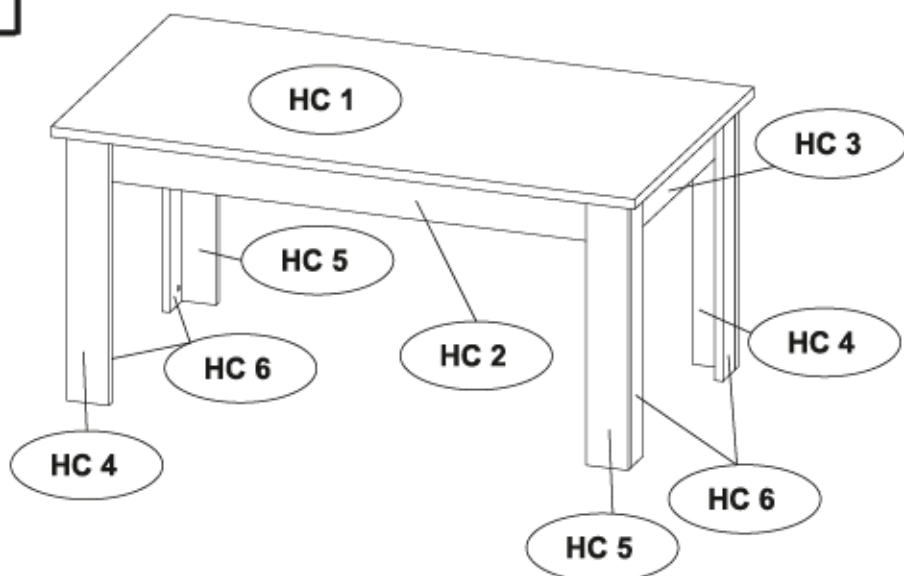

- D** Unser Direktservice für Beschädigte  
Sollte Ihnen ein Beschädigter fallen, können Sie diese Servicekarte direkt an die untenstehende Adresse mailen. Wir können allerdings nur Beschädigte auf diesem Wege verschicken. Sollten Sie eine andere Beauftragung an Ihrem Möbelstück haben, so wenden Sie sich bitte direkt an Ihr Möbelhaus.
- GB** Our direct order service for fitting  
If a fitting part is missing, you can e-mail this service card directly to the address below. However, we can only send fitting parts in this way. If you have any other cause for complaint concerning your item of furniture, please contact your furniture store directly.
- CZ** Naše přímé služby pro kování  
Chybí-li vám nějaký díl z kování, můžete tuto servisní kartu odeslat e-mailem přímo na níže uvedenou adresu. Touto cestou však můžeme zoslat jen díly kování. Pokud byste reklamovali jiný díl nábytku, obraťte se přímo na svého prodejce nábytku.
- F** Bien utiliser la notice de montage  
Si vous manquez une ferrure, veuillez envoyer directement la présente carte service à l'adresse e-mail indiquée ci-dessous. Cependant, ceci nous permet uniquement d'envoyer des ferrures. Pour tout autre type de réclamation concernant votre meuble, veuillez contacter directement votre magasin d'ameublement.
- I** Il nostro servizio diretto per l'ordine della ferramenta  
Qualora Vi dovesse mancare un pezzo di fissaggio, allora Vi preghiamo di inviare questa carta di servizio immediatamente all'indirizzo sottostante. Possiamo inviare i pezzi di fissaggio solamente per mezzo di questo procedimento. Qualora doviate avere qualche altra reclamazione in merito al mobile, allora Vi preghiamo di rivolgervi direttamente al Vostro Negozio di mobili.
- BG** НАМАТИ ДИРЕКТНИ УСЛУЖИ ЗА ОБЕДИ  
Ако липневат части от комплектта, потърсете насоката сервисна карта и я изпратете на e-mail адреса, посочен по-долу. По този начин можем да доставим само липващи елементи от обекта. Ако установите други дефекти на мебелта, Ви съветваме да се обрнете към мебелната експлоатация, от която сте закупили стоката.
- NL** Onze directservice voor losse onderdelen  
Wanneer er een onderdeel ontbreekt, kunt u deze servicekaart direct aan onderstaand e-mailadres sturen. Wij kunnen langa deze weg echter alleen losse onderdelen versturen. Mocht u een ander probleem aan uw meubel hebben, verzoekten wij u contact op te nemen met uw meubeldealer.
- PL** Nasz bezpośredni serwis części montażowych  
Jeżeli brakuje części koniecznych do montażu, prosimy o przesłanie nam niniejszej karty serwisowej na niżej podany adres e-mailowy. W ten sposób możemy przesyłać jedynie brakujące części. W przypadku innych reklamacji dotyczących mebla, prosimy zgłosić się do salonu meblowego, w którym został dokonany zakup.
- HR** Servis za okove  
U slučaju da nedostaje neki od dijelova molimo vas da na dole navedenu mail adresu pošaljete ovaj servisni obrazac. Na ovaj način mogu se dostaviti samo okovi. U slučaju da imate dodatne prigovore vezane uz komad namještaja molimo vas da se obratite izravno trgovini namještaja gdje je bili kupljen.
- HU** Direktszolgáltatunk vasalátok esetén  
Ha hiányzik egy vasalat, ezt a kártyát közvetlenül elküldheti az alább látható címre. Azonban csak a vasalatokat tudunk így küldeni. Amennyiben másfajta reklamációt állt fel birtoklásátjánál, forduljon közvetlenül a boltiáruházhoz.
- SK** Naše priama služba pre škádl kovania  
Ak by Vám chýbala niekajá časť kování, môžete poslať túto servisnú kartu poslať e-mailom na nižšie uvedenú adresu. Dieľa kování vieme poslať iba týmto spôsobom. Ak by ste mali inú reklamáciu ohľadom Vášho nábytku, obráťte sa priamo na Vašu predajňu nábytku.
- SLO** Naše direktno uslužbe službe za okovje  
Če vam manjka kakšno okovje, lahko to servišno kartico pošljete po e-pošti direktno na spodnji naslov. Po tej poti vam lahko pošljemo samo okovje. Če želite reklamirati kakšen drug del pohištva, se obrnite neposredno na vašo trgovino pohištva.
- RO** Servisul direct pentru feronerie  
In cazul în care vă lipseşte o piesă de feronerie puteţi să trimiteţi direct acest card de service prin e-mail la adresa de mai jos. Noi nu putem expedia piese de feronerie decât pe această cale. Dacă aveţi o altă reclamaţie referitoare la piesa de mobilier, atunci vă rugăm să vă adresaţi direct la magazinul dvs. de mobilă.
- RUS** Наш прямой сервис для поставок фурнитуры  
Если окажется, что Вам не хватает того или иного элемента фурнитуры, Вы можете отправить сервисную карту по факсу непосредственно на нижеприведенный адрес электронной почты. Однако, таким образом мы можем отправить лишь фурнитуру. Если же у Вас возникнут иные претензии относительно приобретенной мебели, пожалуйста, обращайтесь непосредственно в организацию, осуществляющую продажу.
- S** Vår direktservice för bestådelar  
Om du saknar en bestådel kan du skicka detta servicekort direkt till o-postadressen som anges nedan. Tänk på att detta är den enda möjligheten att skicka bestådelar till dig. Om du vill reklamera din möbel av annan anledning måste du kontakta ditt möbelförhandlare.
- ES** Nuestro servicio directo para accesorios  
Si le falta algún accesorio, puede enviar este tarjeta de servicio directamente a la siguiente dirección. No obstante, por este método solo podemos enviar accesorios. Si tiene alguna otra objeción sobre su mueble, consulte directamente con su mueblería.
- TR** Donatılar için doğrudan servisimiz  
Bir donatınız eksikse bu servis kartını doğrudan aşağıda bulunan adrese doğrudan mail yollayabilirsiniz. Sadece bu yolla donatılar gönderilebilir. Mobilyanızda başka şikayetleriniz varsa lütfen doğrudan mobilya satıcınıza danışın.

HC 1	x1	1596	896	28	1/1
HC 2	x2	1446	124	22	1/1
HC 3	x2	783	124	22	1/1
HC 4	x2	729	115	22	1/1
HC 5	x2	729	115	22	1/1
HC 6	x4	729	93	22	1/1

# RAVENNA 02

**D** Unser Direktservice für Beschädigte  
 Sollte Ihnen ein Beschädigtes fehlen, können Sie diese Servicekarte direkt an die untenstehende Adresse mailen. Wir können allerdings nur Beschädigte auf diesem Wege ersetzen. Sollten Sie eine andere Bausituation an Ihrem Möbelstück haben, so wenden Sie sich bitte direkt an Ihr Möbelhaus.

**GB** Our direct order service for fitting  
 If a fitting part is missing, you can e-mail this service card directly to the address below. However, we can only send fitting parts in this way. If you have any other cause for complaint concerning your item of furniture, please contact your furniture store directly.

**CZ** Naše přímé služby pro kování  
 Chybí-li vám nějaký díl z kování, můžete tuto službu kartou odvést e-mailem přímo na níže uvedenou adresu. Touto cestou však můžeme nahradit jen díly kování. Pokud byste měli jiné problémy či nářky, obraťte se přímo na svého prodejce nábytku.

**F** Bien servir: la notice de montage  
 Si vous manquez une ferrure, veuillez envoyer directement la présente carte service à l'adresse e-mail indiquée ci-dessous. Cependant, ceci nous permet uniquement d'envoyer des ferrures. Pour tout autre type de réclamation concernant votre meuble, veuillez contacter directement votre magasin d'ameublement.

**I** Il nostro servizio diretto per il cambio delle ferrature  
 Qualora Vi dovesse mancare un pezzo di fissaggio, allora Vi preghiamo di inviare questa carta di servizio immediatamente all'indirizzo sottoelencato. Possiamo inviare i pezzi di fissaggio solamente per mezzo di questo procedimento. Qualora dovete avere qualche altra reclamazione in merito al mobile, allora Vi preghiamo di rivolgerVi direttamente al Vostro Negozio di mobili.

**BG** Изплатна директна услуга за обкова  
 Ако липсваат части от коването, допълнително изплатете сервисна карта и ни я изпратете на e-mail адреса, посочен по-долу. По този начин можем да доставим само липсващи елементи от обкова. Ако установите други дефекти по мебелите, Ви съветваме да се обвържете със мебелната къща/магазин, от който сте закупили стоката.

**NL** Onze directservice voor leen ontbrekend  
 Wanneer er een onderdeel ontbreekt, kunt u deze servicekaart direct aan onze afdeling e-mailadres sturen. Wij kunnen leen deze weg echter alleen beschadigen vasturen. Mocht u een ander probleem aan uw meubel hebben, verzoeken wij u contact op te nemen met uw meubeldealer.

**PL** Nasz bezpośredni serwis części montażowych  
 Jeżeli brakuje części koniecznych do montażu, prosimy o przesłanie nam niniejszej karty serwisowej na niżej podany adres e-mailowy. W ten sposób możemy przesłać Państwu tylko brakujące części. W przypadku innych reklamacji dotyczących mebla, prosimy zgłosić się do salonu meblowego, w którym został dokonany zakup.

**HR** Servis za okove  
 U slučaju da nedostaje neki od dijelova molimo vas da na dole navedenu mail adresu pošaljete ovaj servišni obrazac. Na ovaj način mogu se dostaviti samo okovi. U slučaju da imate dodatne prigovore vezane uz komad namještaja molimo vas da se obratite izravno trgovini namještaja gdje je isti kupljen.

**HU** Direktszolgálatunk vasalataik esetén  
 Ha hiányzik egy vasalat, ezt a kártyát közvetlenül elküldheti az alább található címre. Azonban csak a vasalataikat tudunk így küldeni. Amennyiben másfajta reklamáció áll fenn bifordambájt illetően, forduljon közvetlenül a boltiáruházhoz.

**SK** Naše přímé servis pro škáň kovania  
 Ak by Vám chýbala nejaká časť kování, môžete poslať túto servisnú kartu poslať e-mailom na nižšie uvedenú adresu. Týmto kováňo vieme poslať iba týmto spôsobom. Ak by ste mali inú reklamáciu ohľadom Vášho nábytku, obráťte sa priamo na Vašu predajňu nábytku.

**SLO** Naše direktno uslužbo storitve za okovje  
 Če vam manjka kakšno okovje, lahko to servišno kartico pošljete po e-pošti direktno na spodnji naslov. Po tej poti vam lahko pošljemo samo okovje. Če želite reklamirati kakšen drug del pohištva, se obrnite neposredno na vašo trgovino pohištva.

**RO** Serviciu-ul nostru direct pentru feronerie  
 In cazul in care va lipseste o piesa de feronerie puteti sa trimiti un direct acest card de service prin e-mail la adresa de mai jos. Noi nu putem expedia piese de feronerie decit pe aceasta cale. Dacã aveti o altã reclamație referitoare la piesa de mobilier, atunci vã rugãm sã vã adresați direct la magazinul div. de mobilã.

**RUS** Наш прямой сервис для поставки фурнитуры  
 Если окажется, что Вам не хватает той или иного элемента фурнитуры, Вы можете отправить сервисную карту по факсу непосредственно на нижеприведенный адрес электронной почты. Однако, таким образом мы можем переслать лишь фурнитуру. Если же у Вас возникнет иное претензия относительно приобретенной мебели, пожалуйста, обращайтесь непосредственно в организацию, осуществляющую продажу.

**S** Vñ direktbenice für beskadigede  
 Om du saknar en beskadiged kan du skicka detta servicekort direkt till e-postadressen som anges nedan. Tänk på att detta är den enda möjligheten att skicka beskadigede till dig. Om du vill reklamera din möbel av en annan anledning måste du kontakta ditt möbelhus direkt.

**ES** Nuestro servicio directo para accesorios  
 Si le falta algún accesorio, puede enviar esta tarjeta de servicio directamente a la siguiente dirección. No obstante, por este método solo podemos enviar accesorios. Si tiene alguna otra objeción sobre su mueble, consulte directamente con su mueblería.

**TR** Donatılar için doğrudan servisimiz  
 Bir donatılar eksikse bu servis kartını doğrudan aşağıda bulunan adrese doğrudan mail yazabilirsiniz. Sadece bu yolla donatıları gönderebiliriz. Mobilyanızda başka şikayetiniz varsa lütfen doğrudan mobilya satıcınıza danışın.

**HCB1** 1018  
  
 8x28 X...

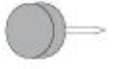
**HCF36** 1305  
  
 X...

**HCM1** 123894  
  
 X...

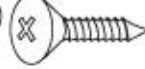
**HCS3** 1011  
  
 3,5x13 X...

**HCT1** 11809  
  
 X...

**HCP14** 1059  
  
 4x35 X...

**HCK15** 81556  
  
 X...

**HCC6** 140318  
  
 φ20 X...

**HCK2** 1311  
  
 7x70 X...

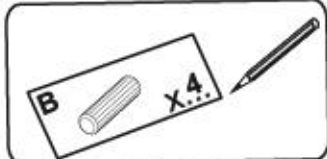

# RAVENNA 27

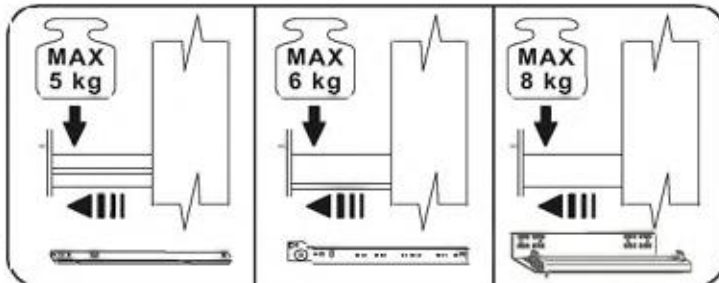
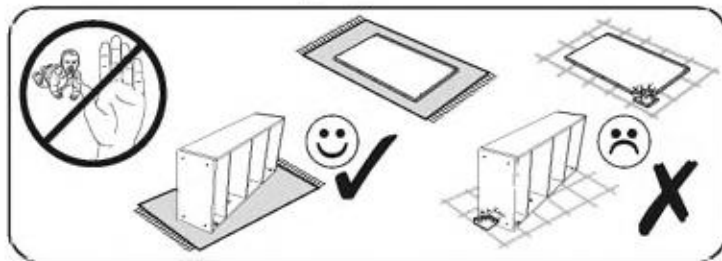
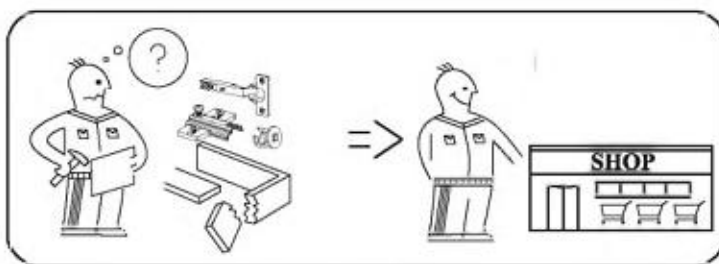
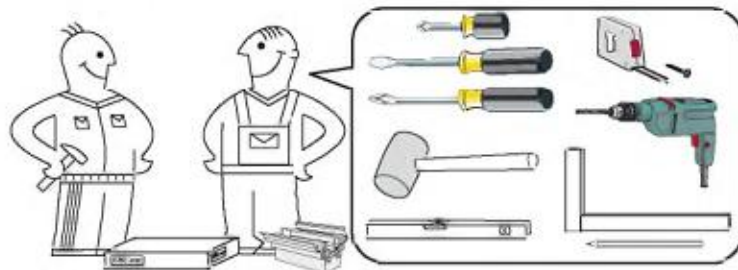
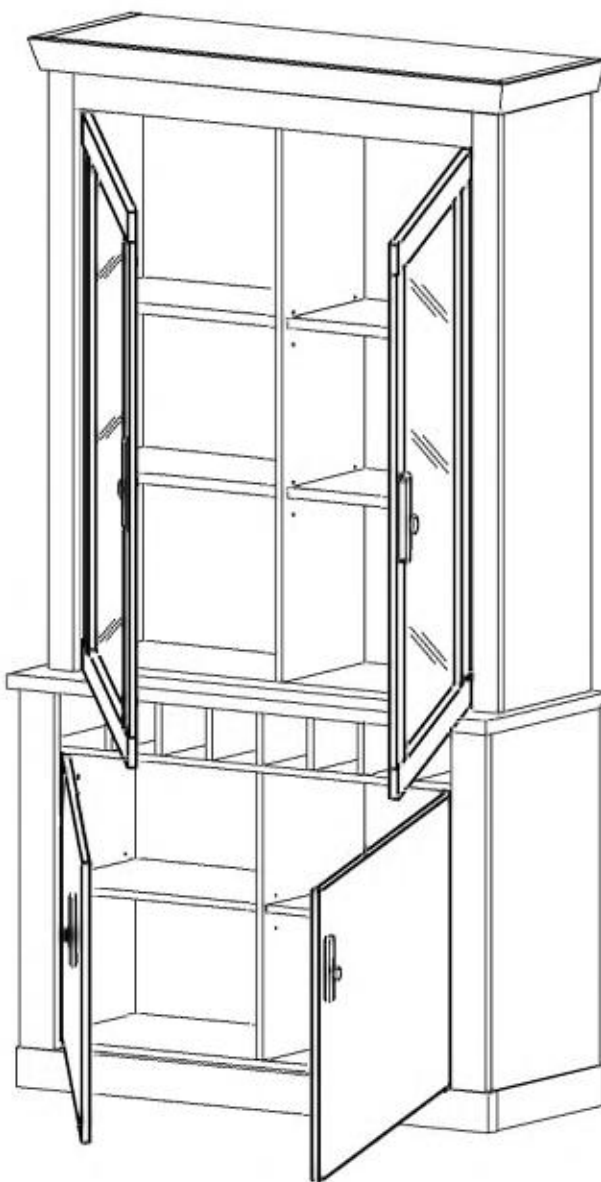
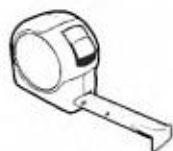
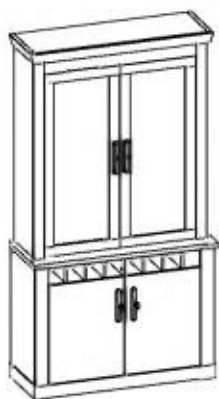

# RAVENNA 27

max.



5kg

HC 158

max.



40kg

HC 151

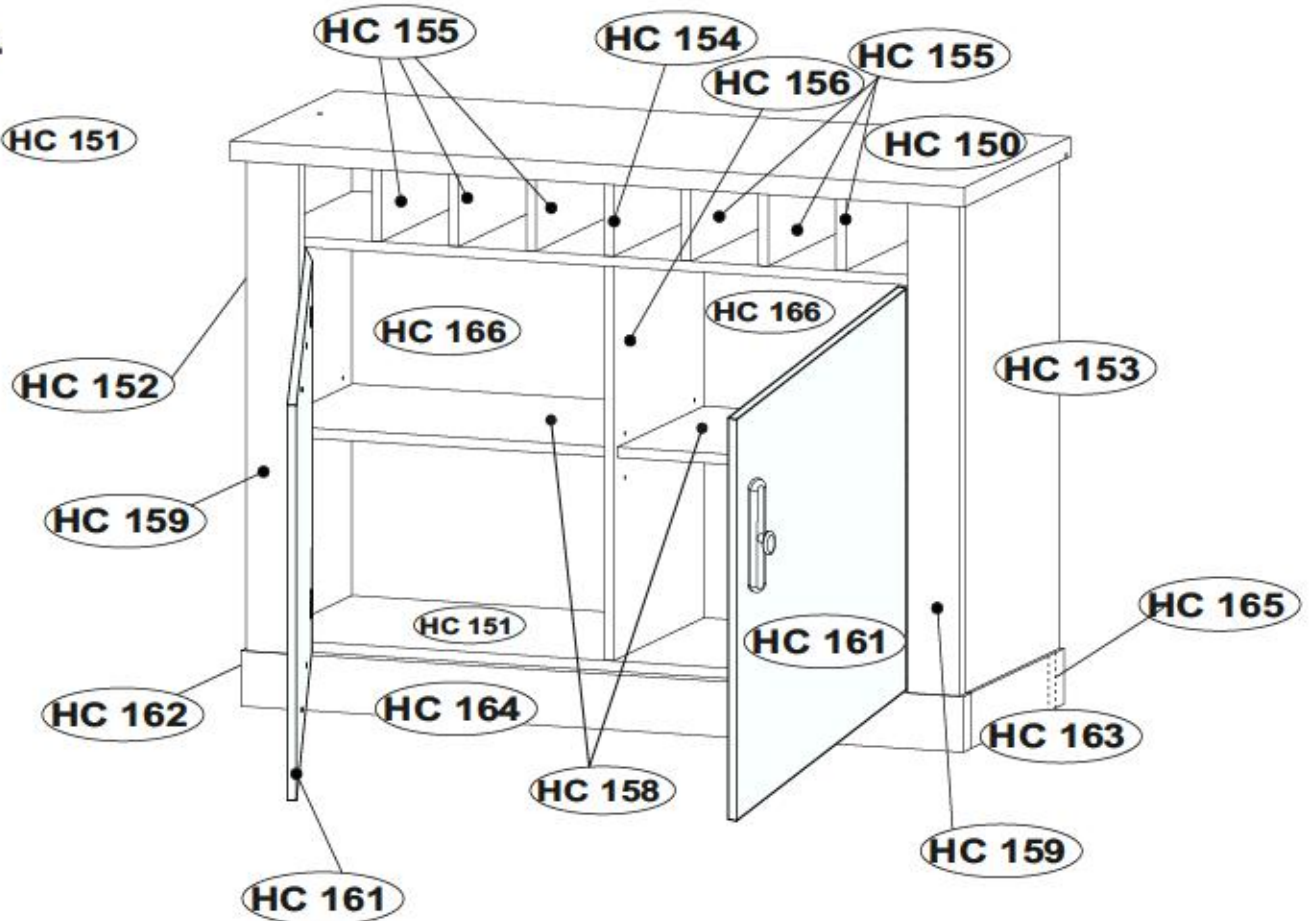

HC 150	x1	1111	440	28	2/3
HC 151	x1	1049	375	15	3/3
HC 152	x1	711	395	15	1/3
HC 153	x1	711	395	15	1/3
HC 154	x1	112	373	15	2/3
HC 155	x6	112	373	15	2/3
HC 156	x1	569	373	15	3/3
HC 157	x1	1049	374	15	3/3
HC 158	x2	516	360	15	3/3
HC 159	x2	711	80	22	1/3
HC 161	X2	593	456	15	2/3
HC 162	x1	392	80	28	2/3

HC 163	x1	392	80	28	2/3
HC 164	X1	1094	80	28	1/3
HC 165	x1	1036	80	28	2/3
HC 166	x2	716	530	2.5	1/3



# RAVENNA 27

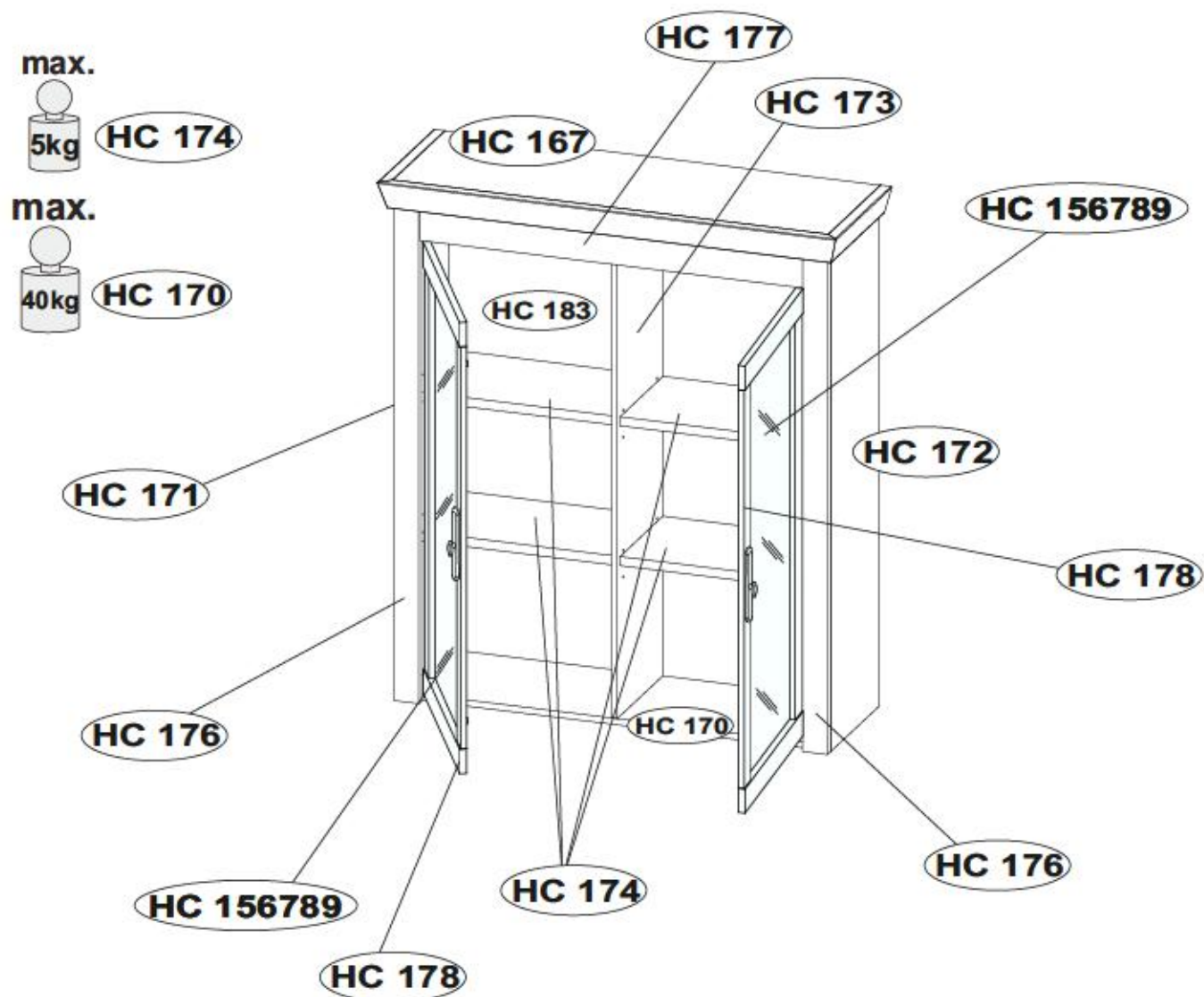



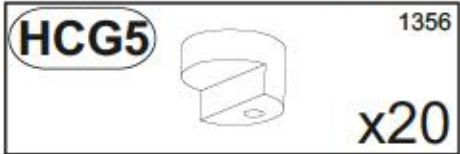
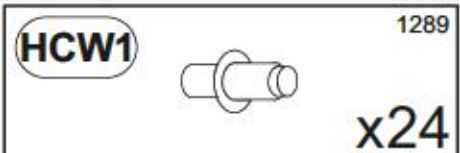
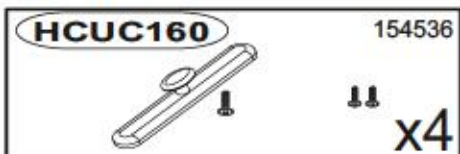
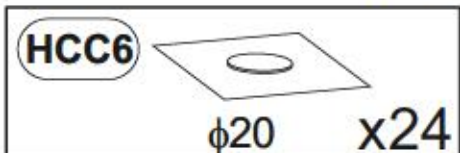
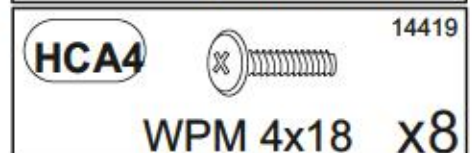
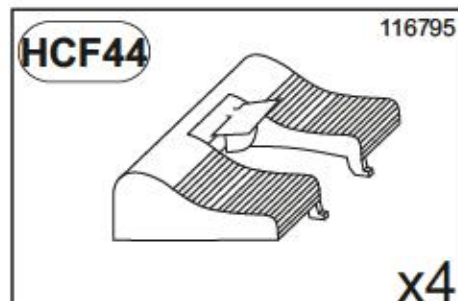
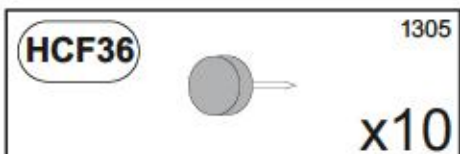
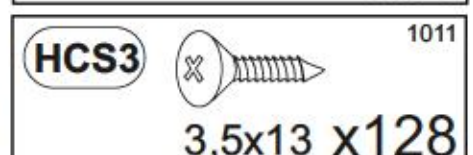
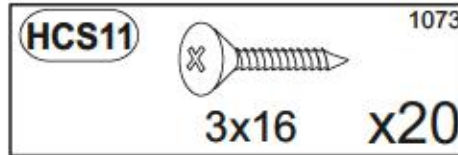
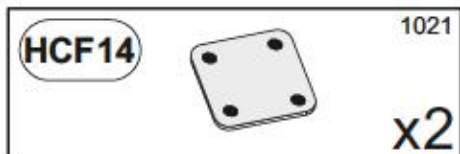
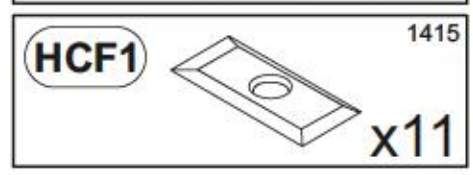
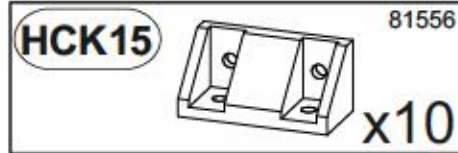
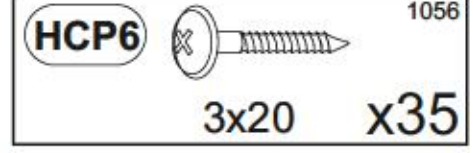
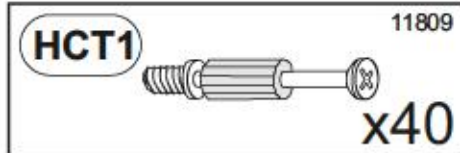
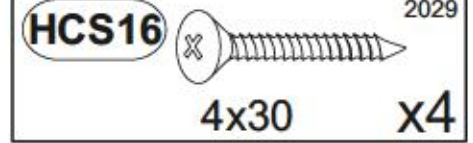
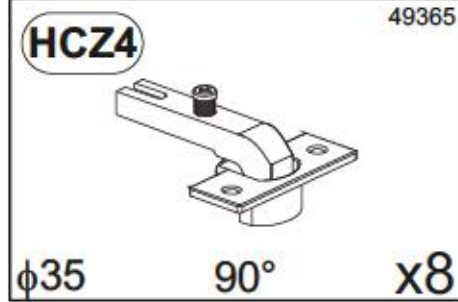
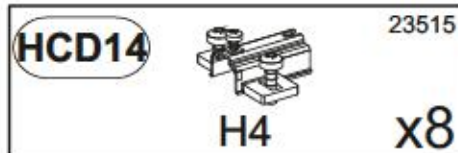
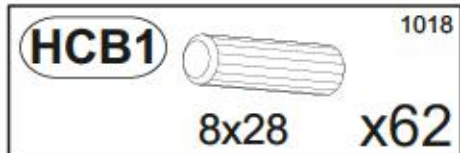

HC 167	x1	1102	371	65	1/3
HC 170	x1	1011	300	15	1/3
HC 171	x1	1236	320	15	3/3
HC 172	x1	1236	320	15	3/3
HC 173	x1	1221	300	15	3/3
HC 174	x4	497	273	22	1/3
HC 176	x2	1236	60	22	1/3
HC 177	x1	921	124	18	2/3
HC 178	x2	1106	456	18	2/3
HC 183	x2	1240	511	2.5	1/3
HC 156789	x2	1016	366	4	2/3

# RAVENNA 27





1

HCM1		123894	x4
HCT1		11809	x8
HCS3		3011	x8
HCK15		81556	x4
HCB1		9018	x4

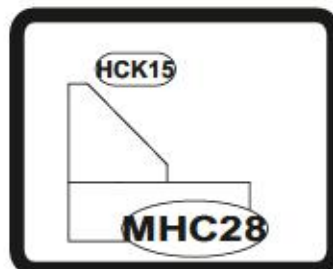
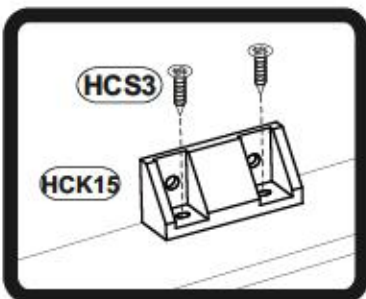
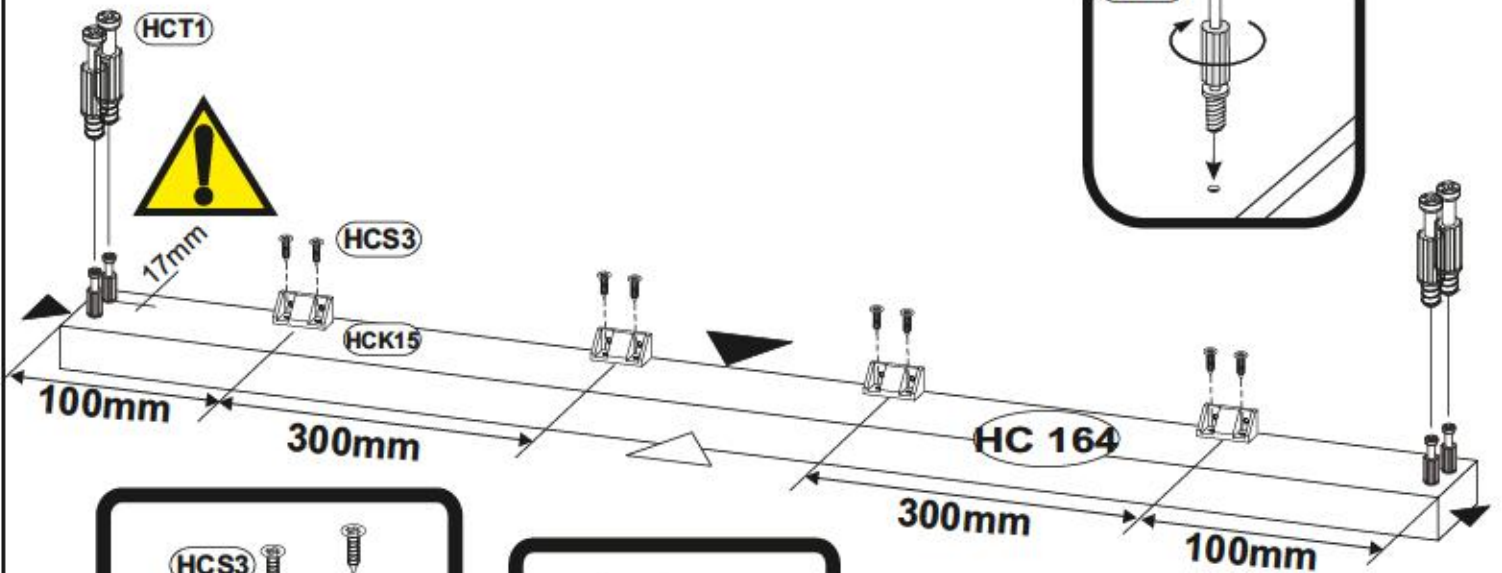
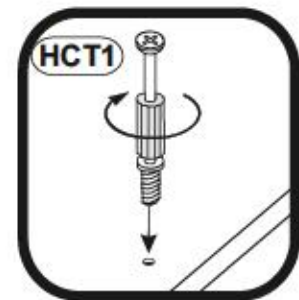
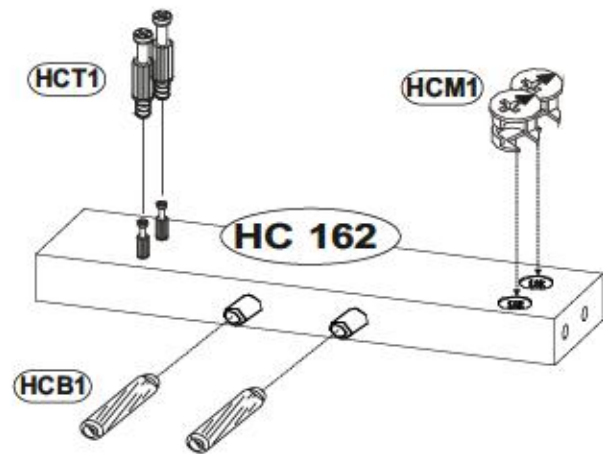
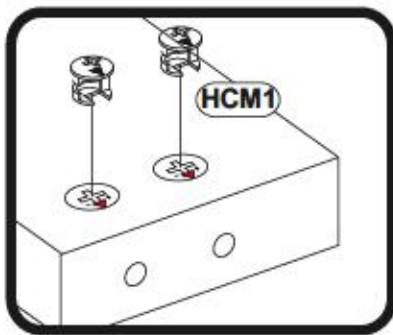
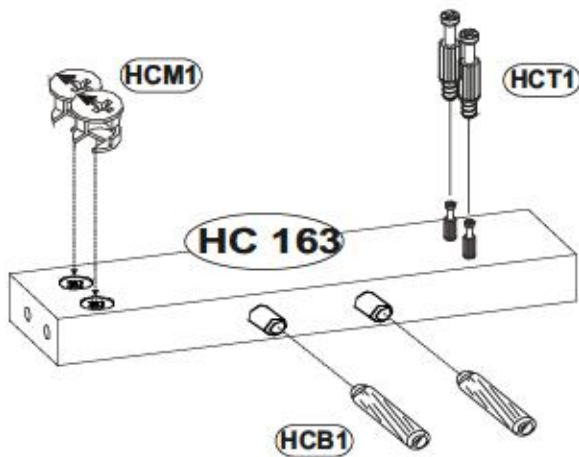

2

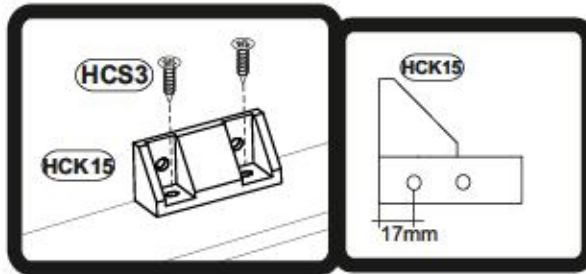

HCM1		123894	x4
HCS3		1011	x8
HCK15		81558	x4

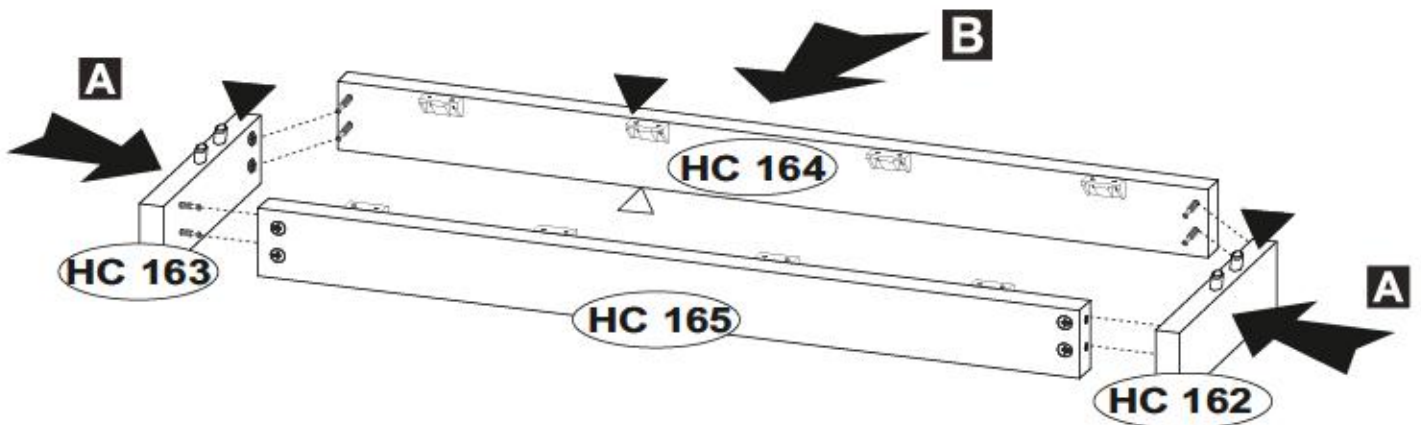
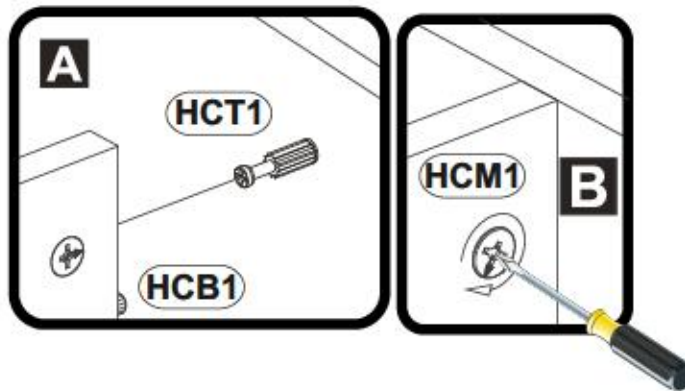
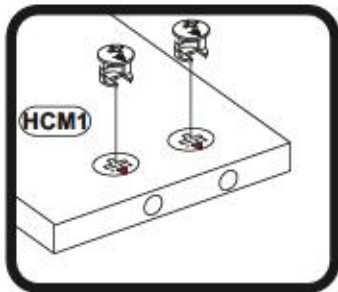
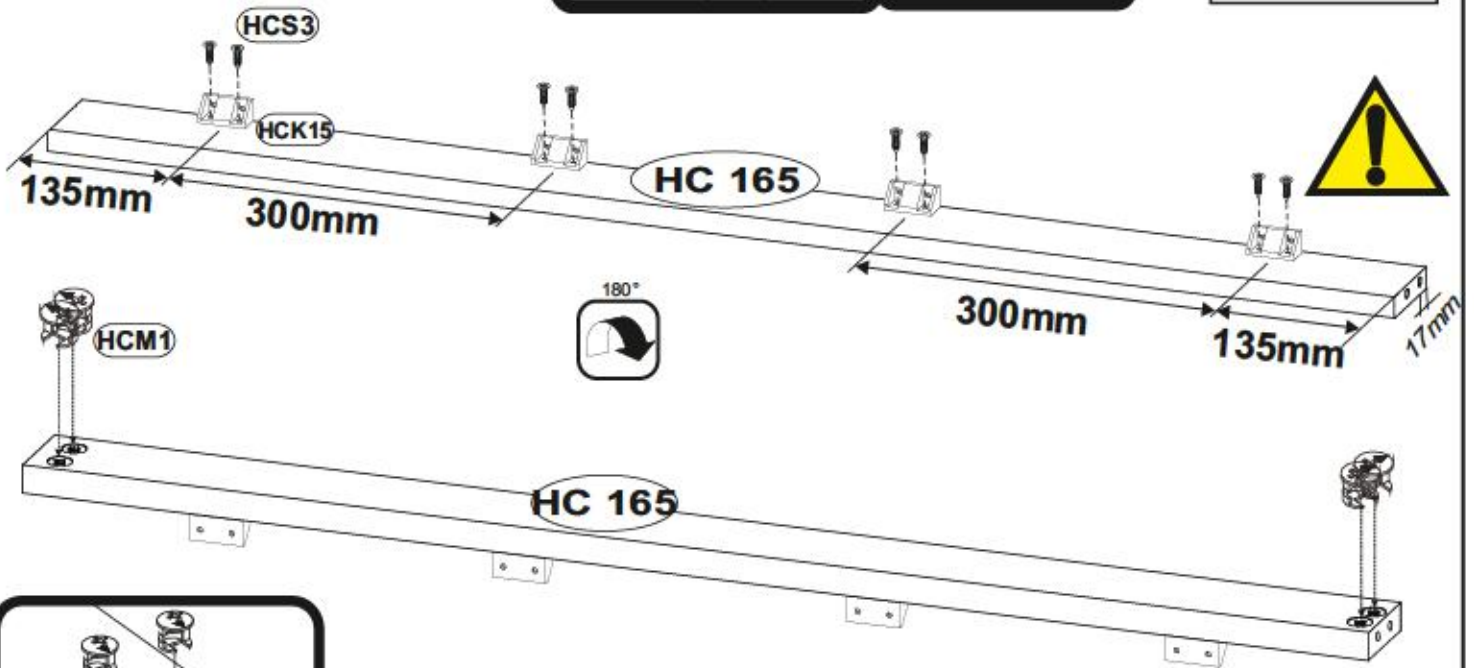

3

HCF36 1305  
x10

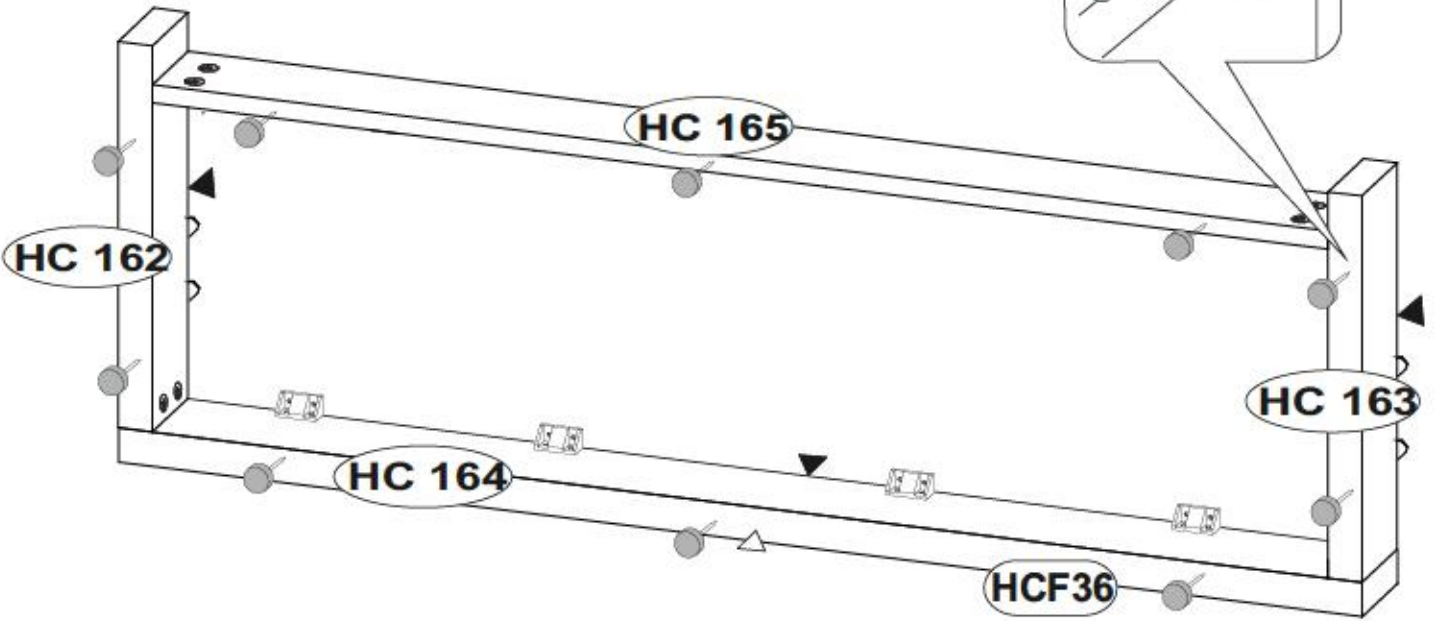
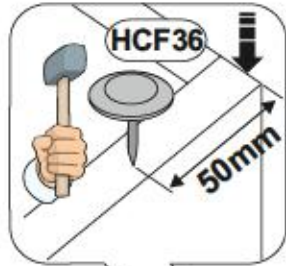

4



HCD14 H4 29.515  
x4

HCK13 407 16  
x8

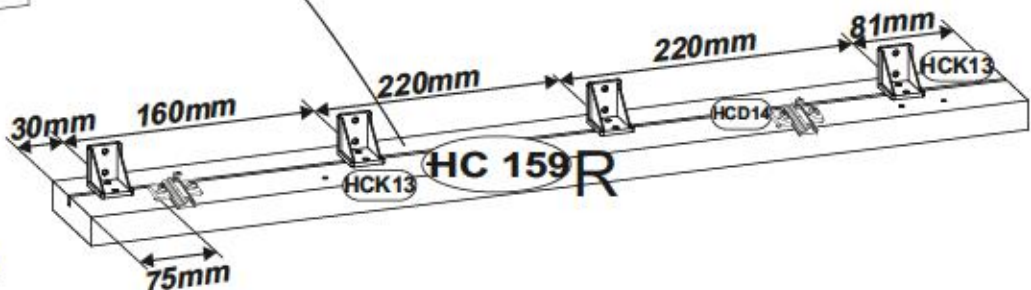
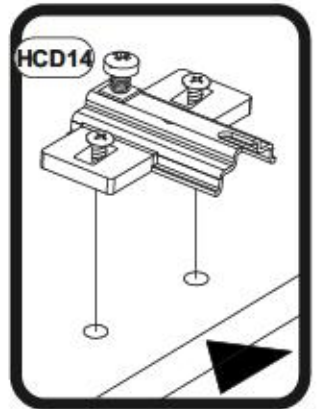
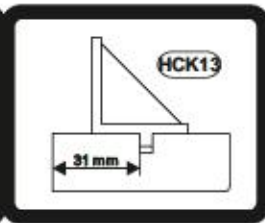
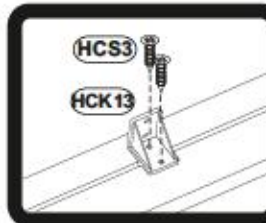
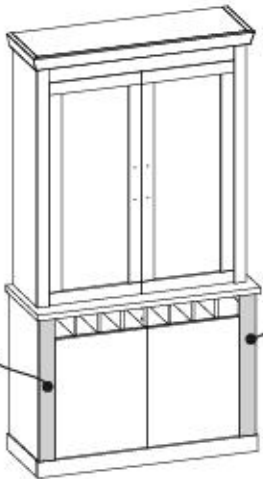
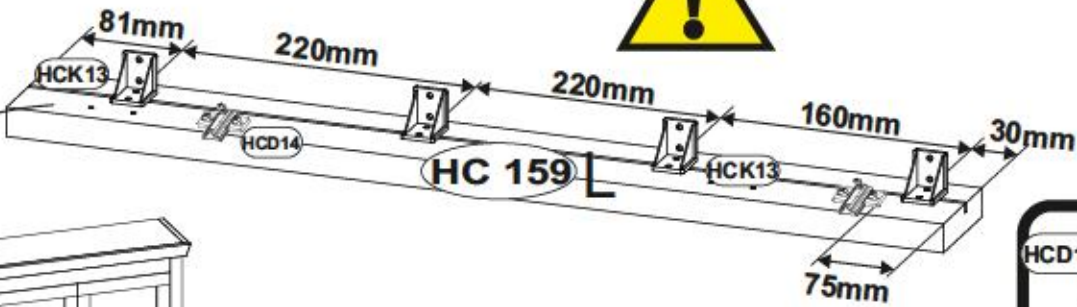
HCS3 1011  
3,5x13 x16



5

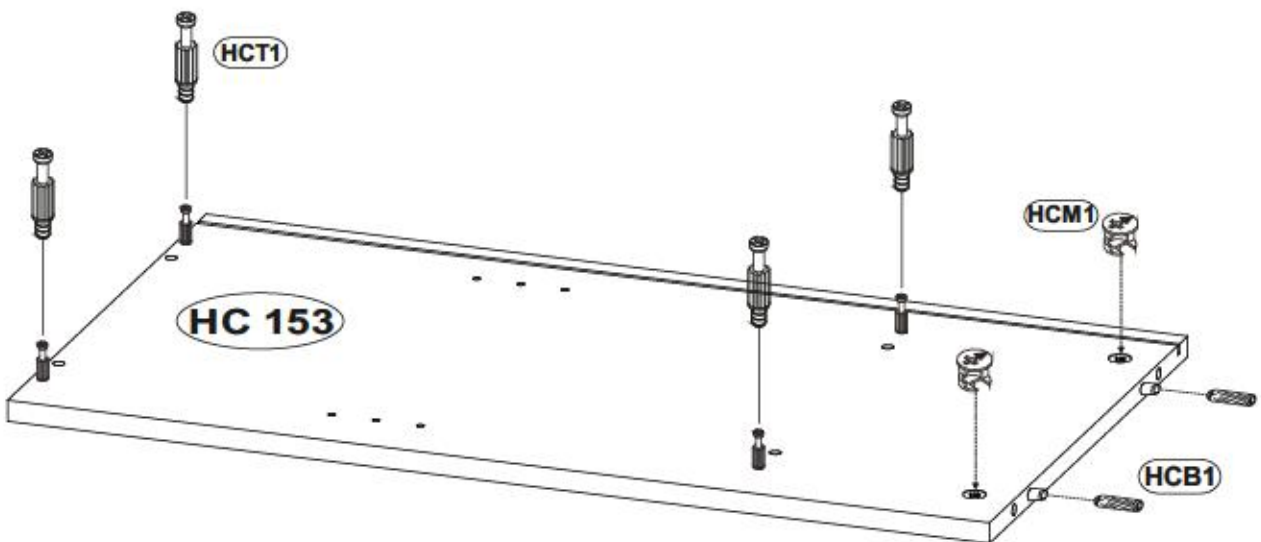
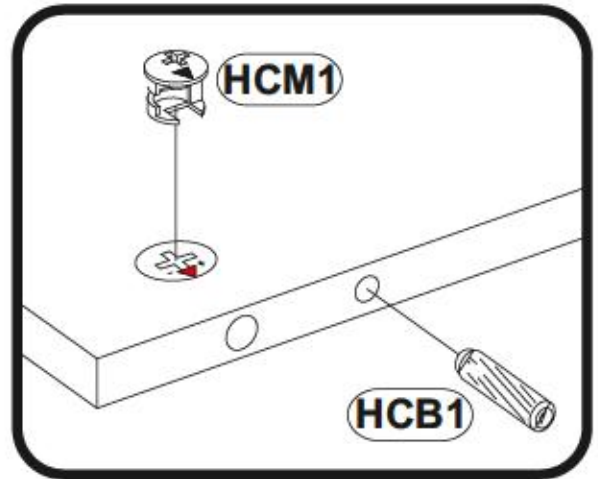
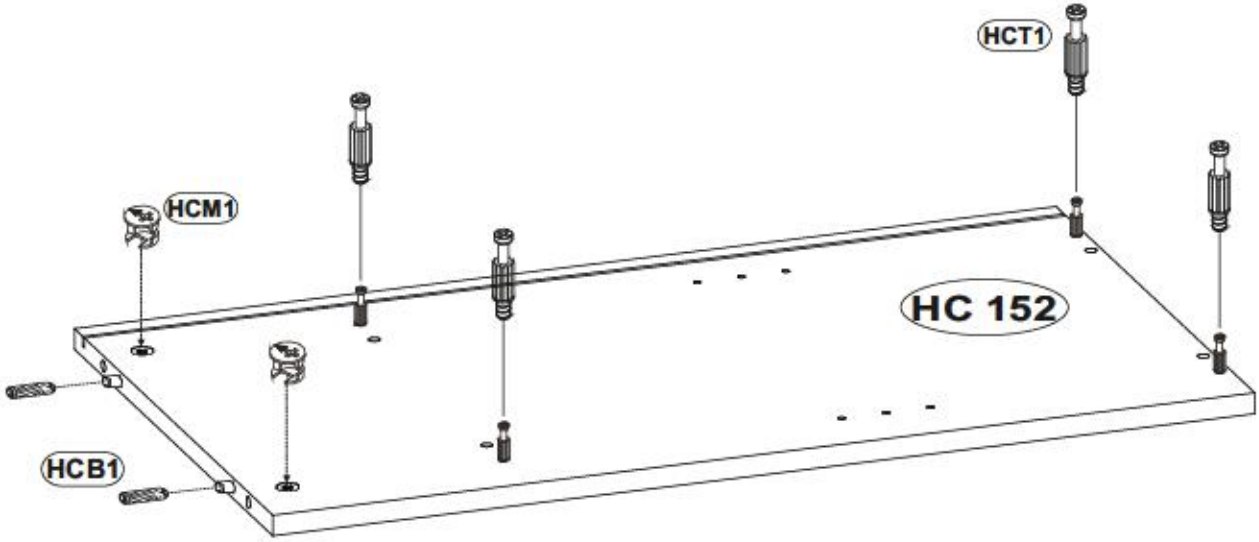

(HCB1)		1018 8x28	x4
(HCM1)		12994	x4
(HCT1)		11809	x8



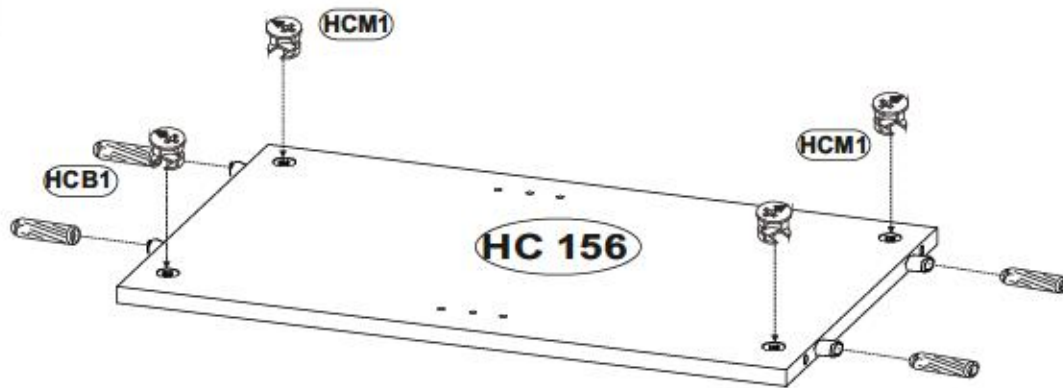

6



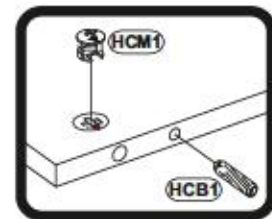

HCM1		123894
		x4
HCB1		1018
		x4

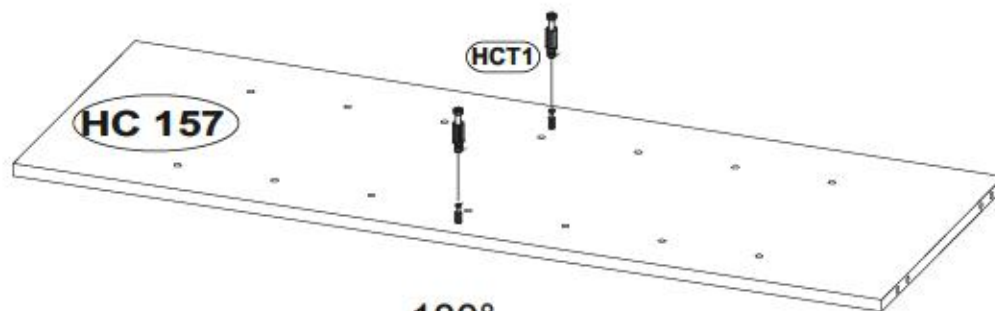

7



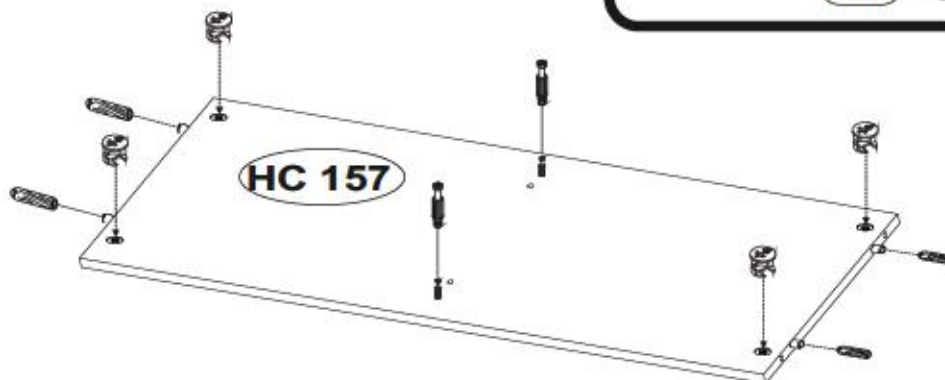
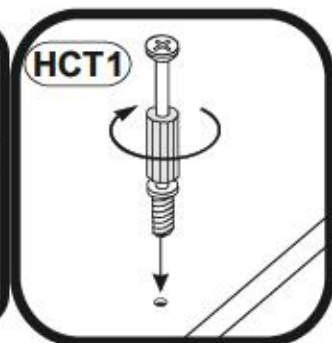
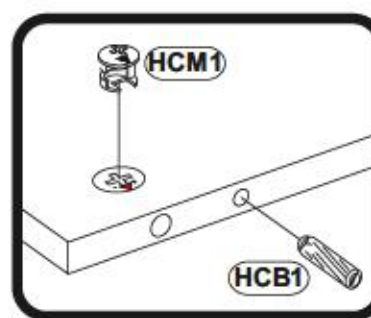

HCM1		123894
		x4
HCT1		11809
		x4
HCB1		1018
		x4

180°



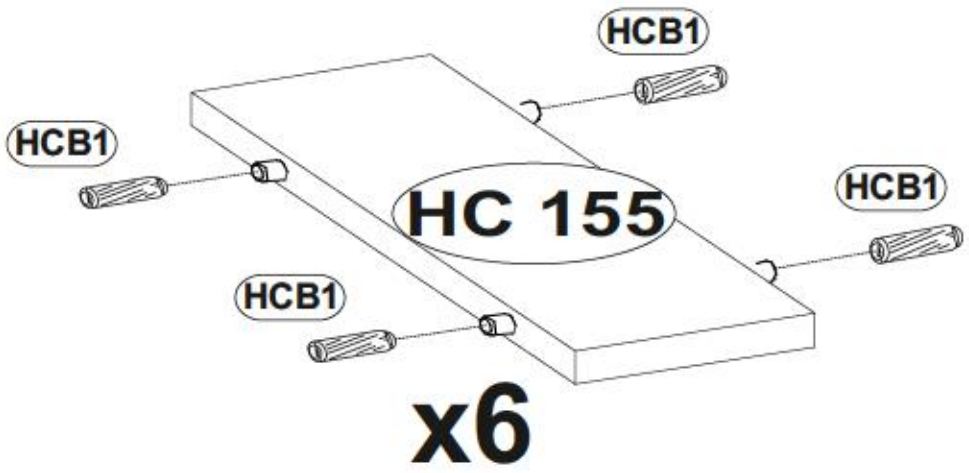
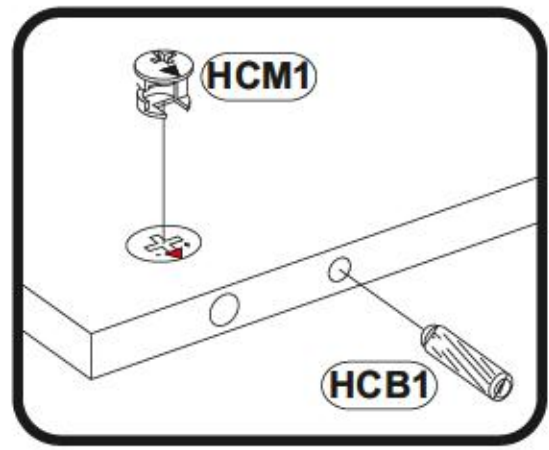
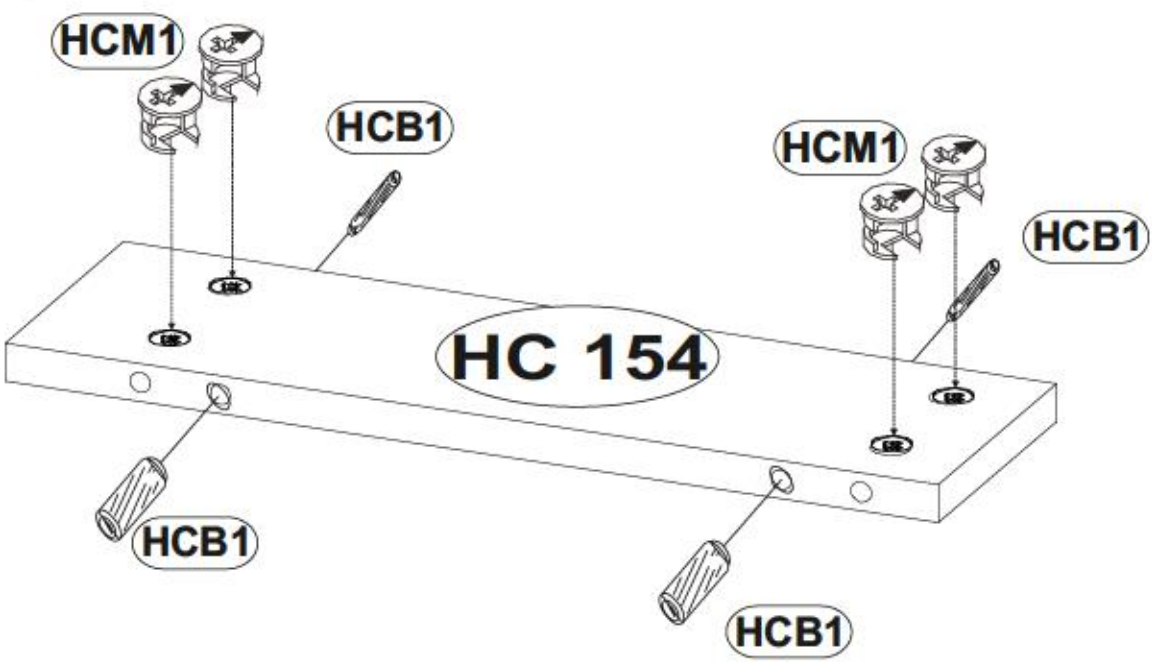

8

HCB1		10 18
	8x28	x28
HCM1		12 38 94
		x4





9

HCM1		123894
		x4
HCT1		15809
		x8
HCB1		1018
	8x28	x4

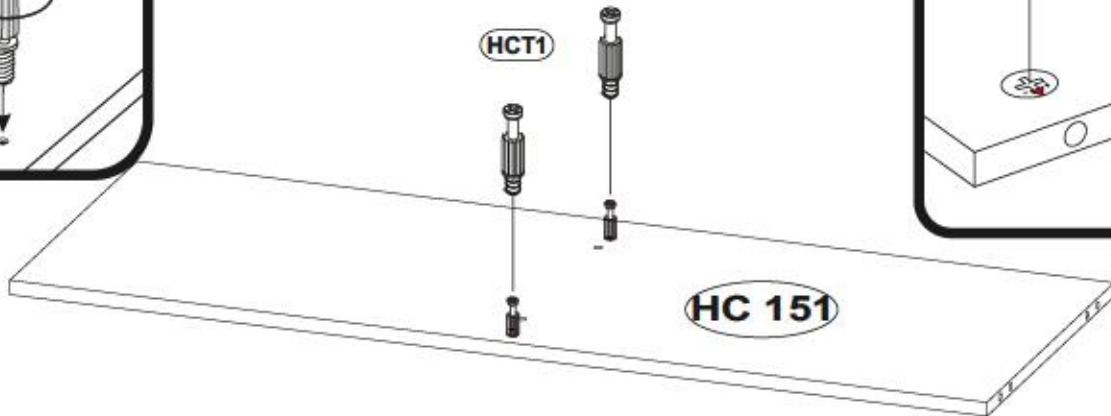
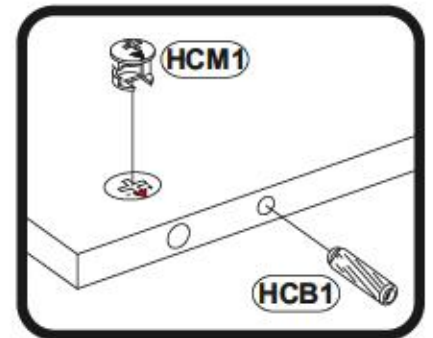
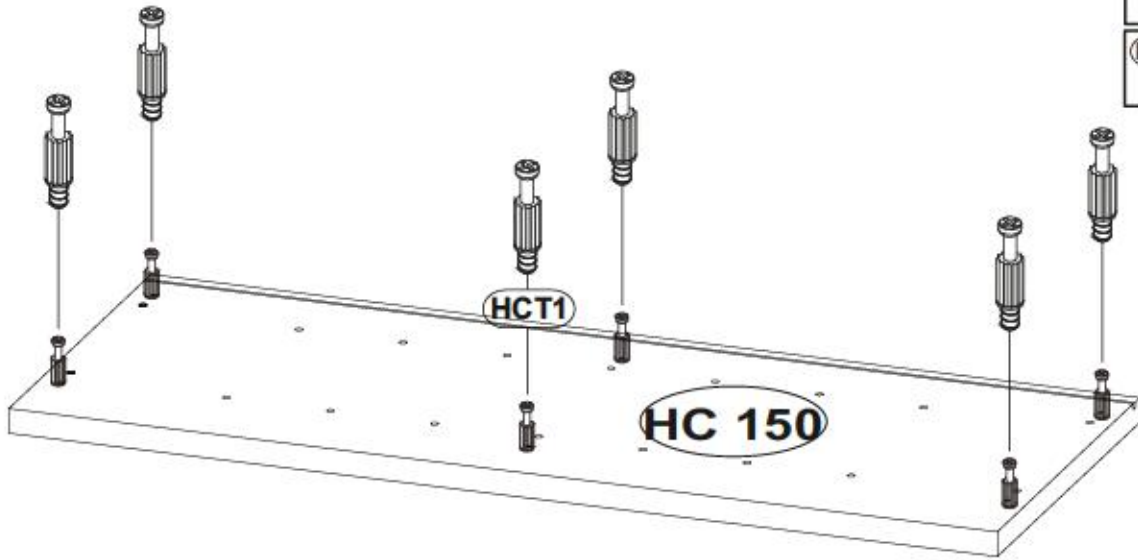

180°

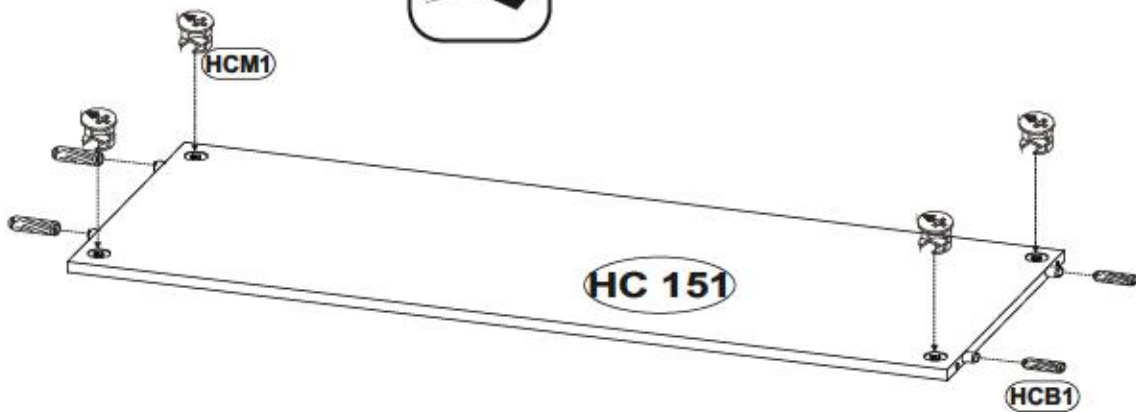

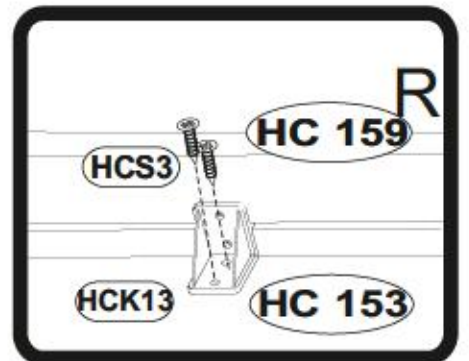
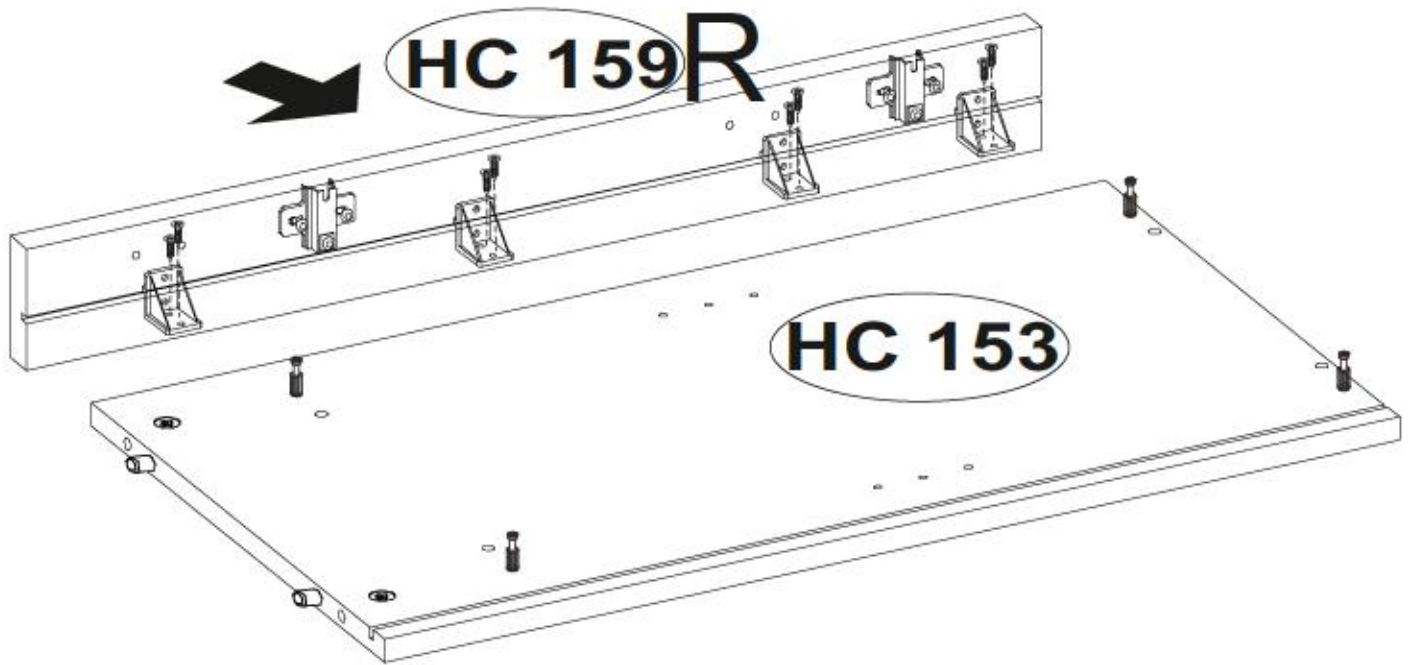
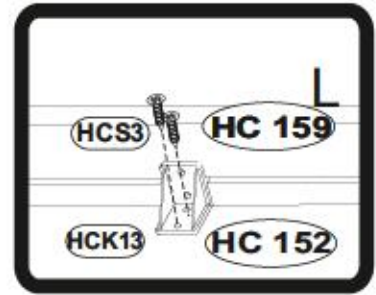
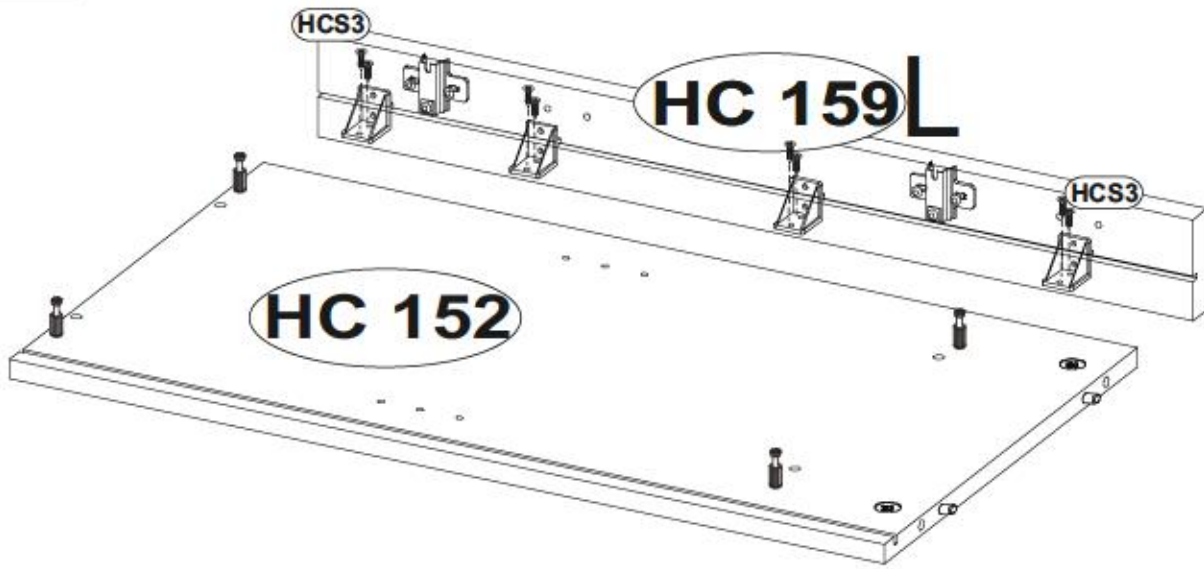

11

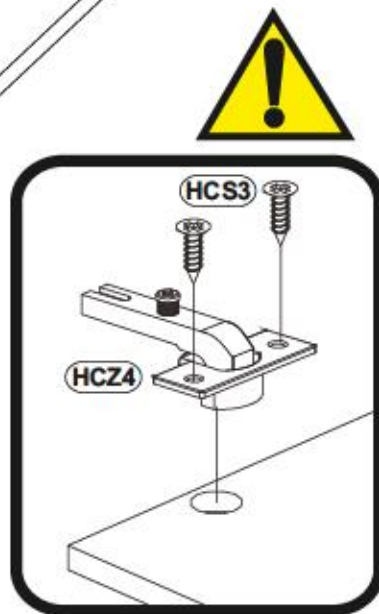
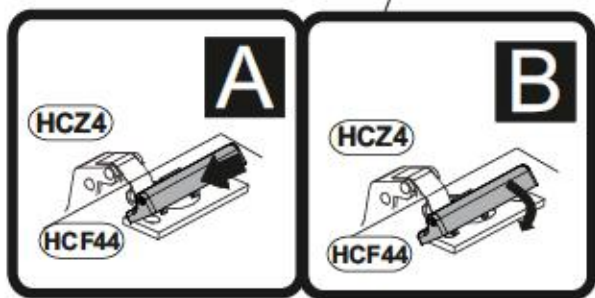
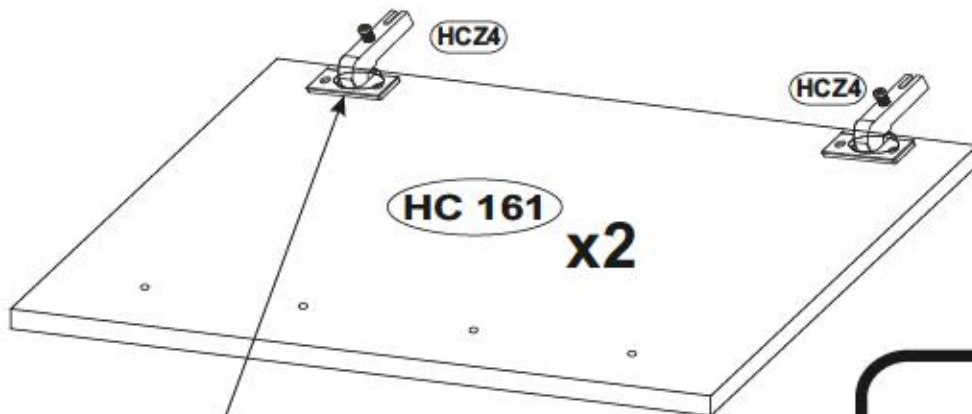
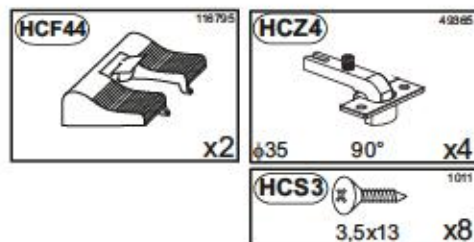

12

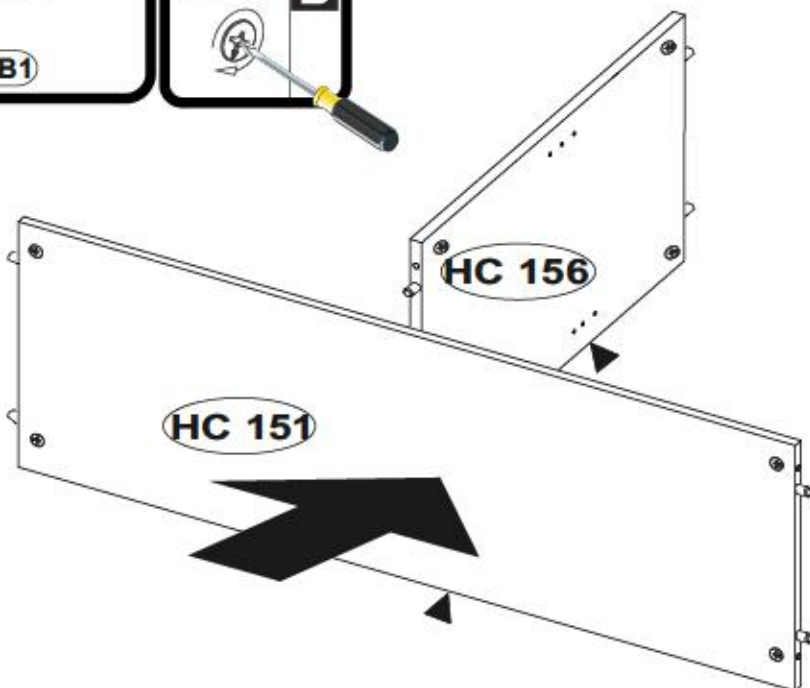
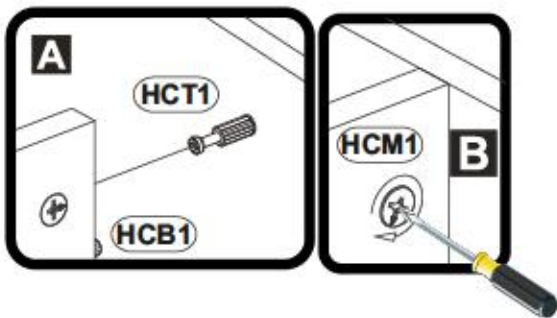

13

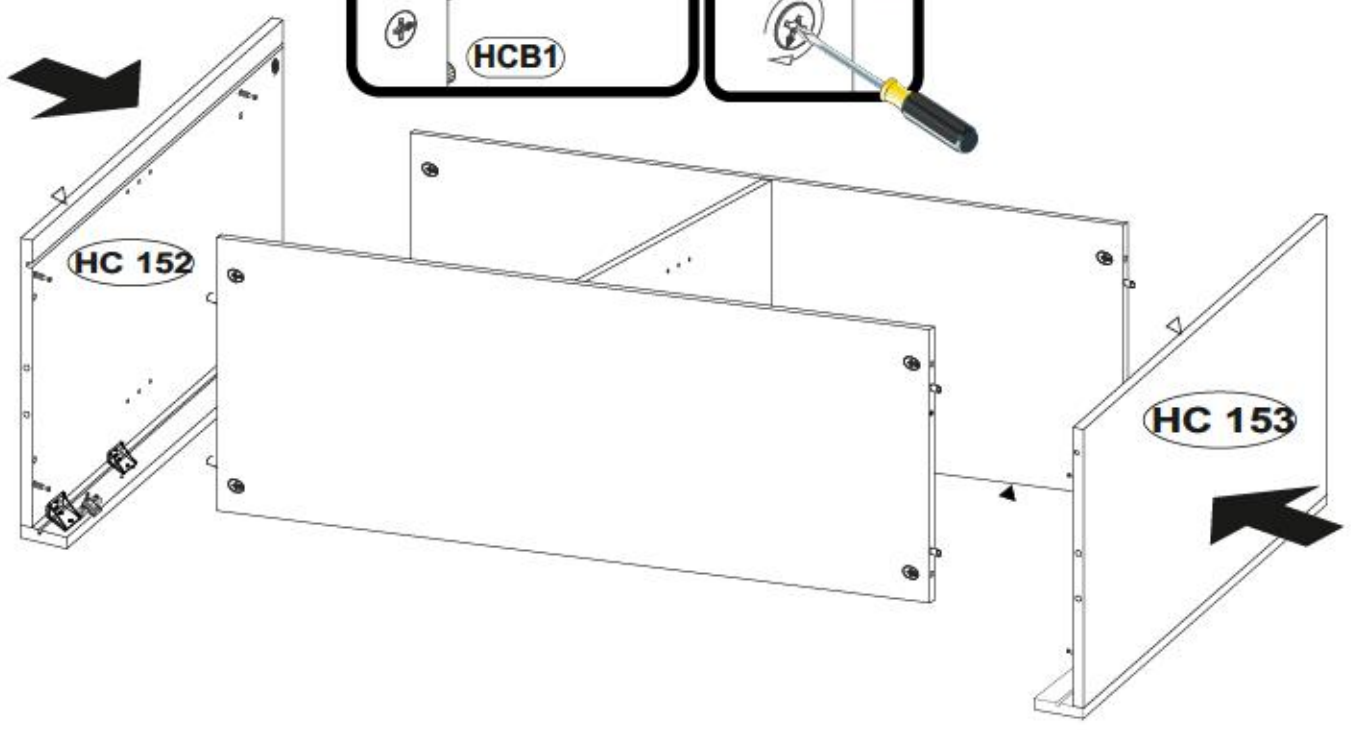
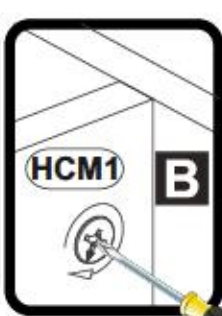
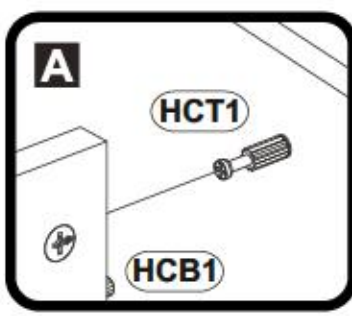
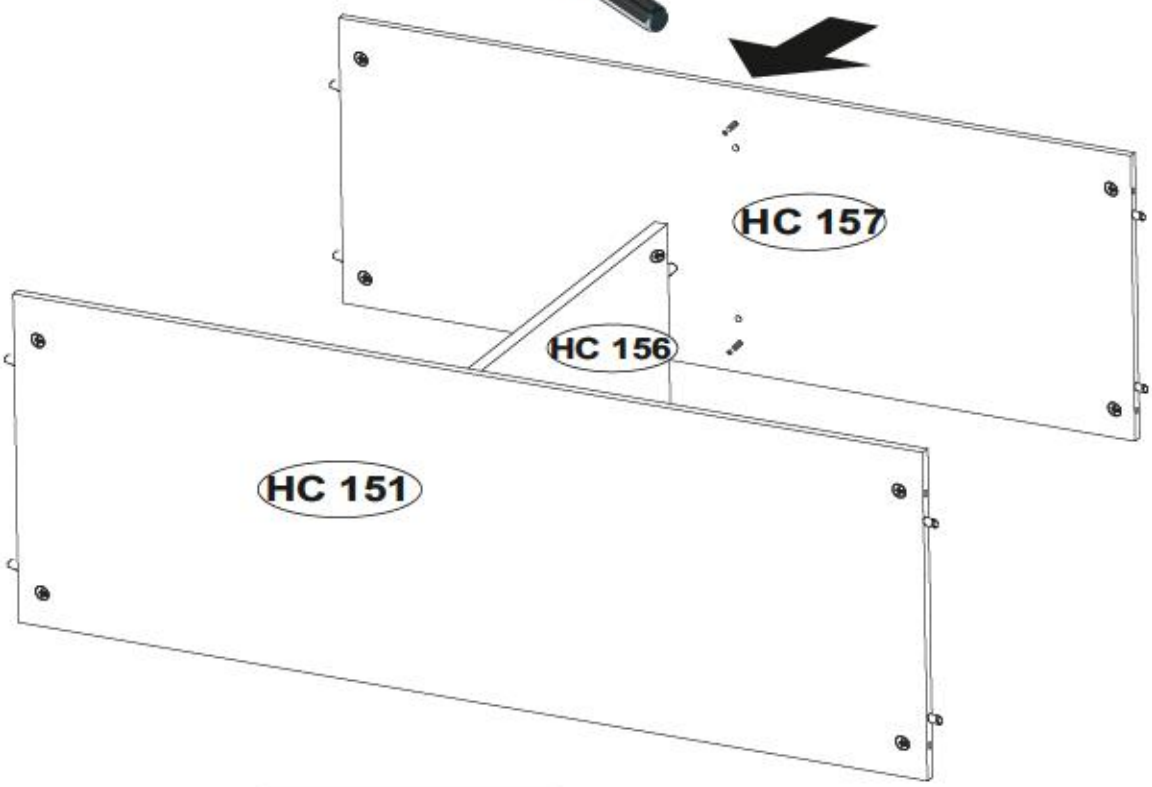
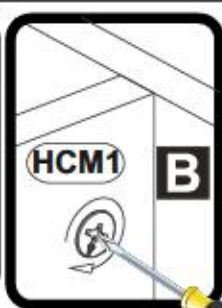
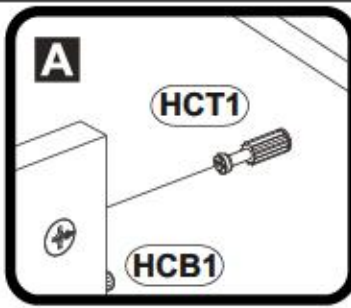

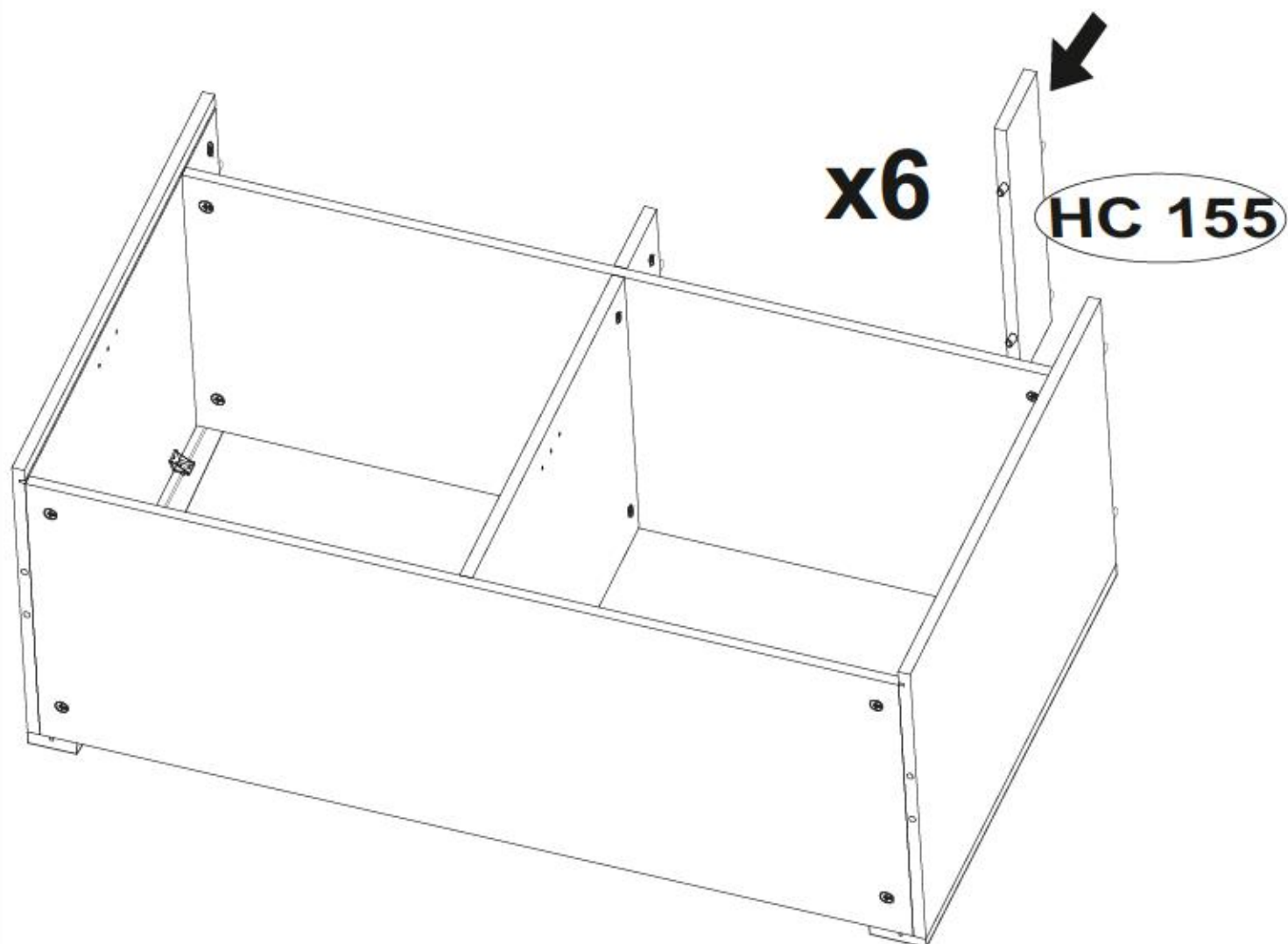
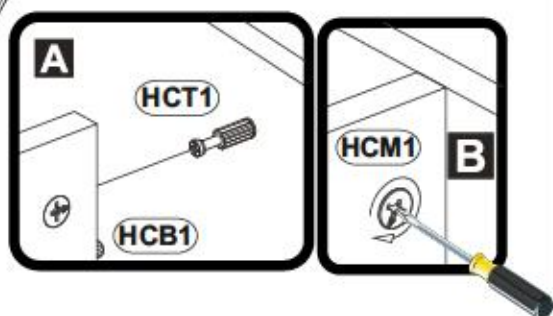
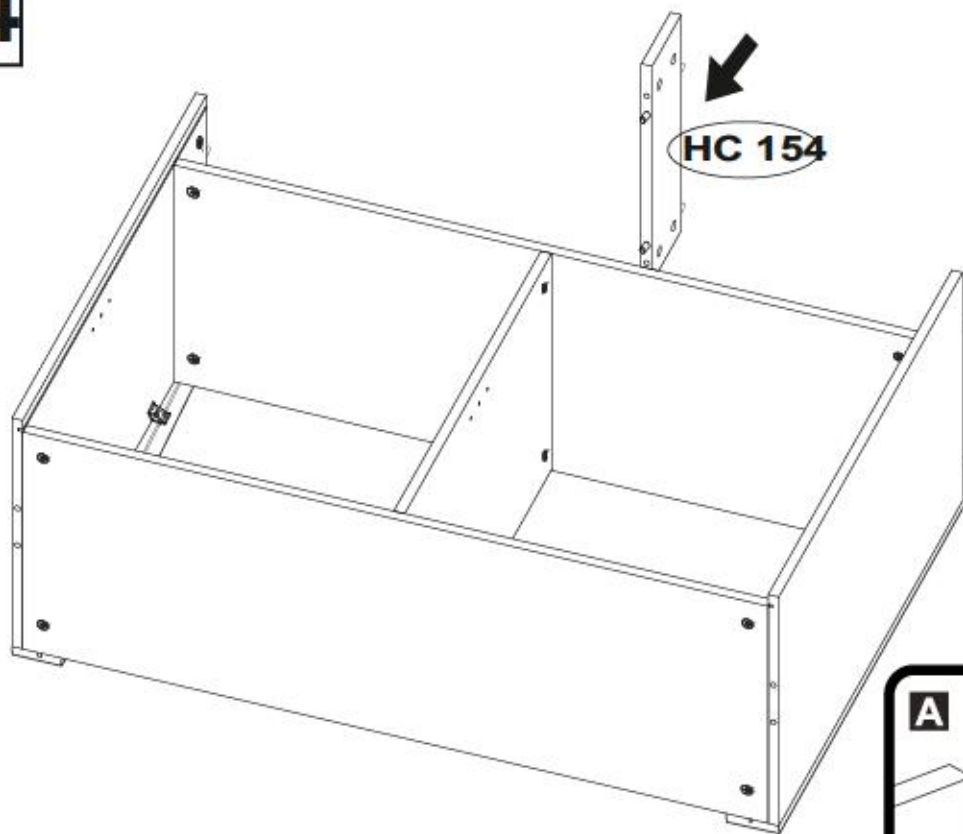

14



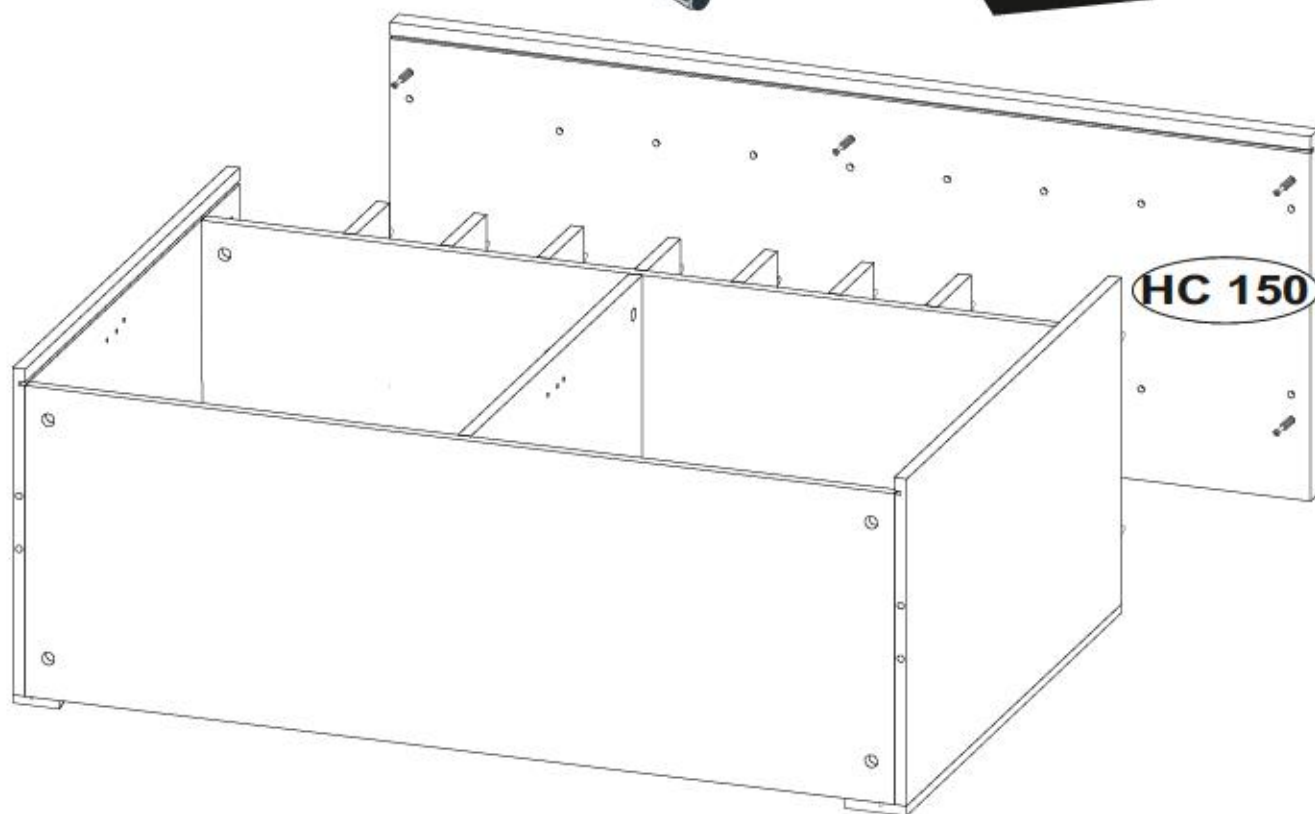
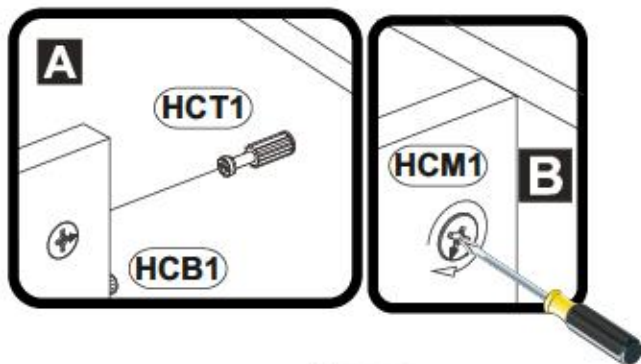





HCJ23		1302
		x8
HCP6		1099
	3x20	x21
HCF1		1415
		x5

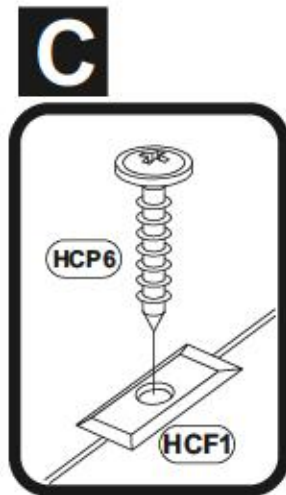
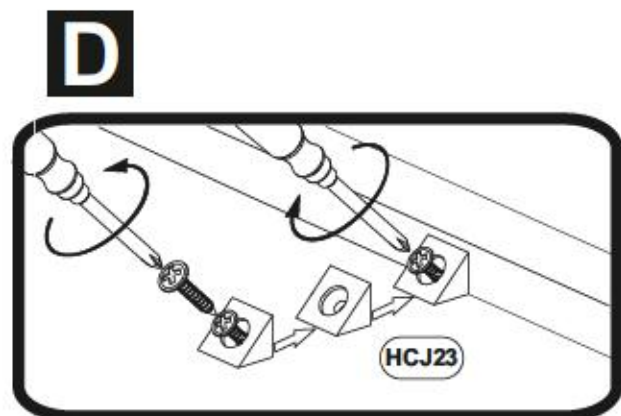
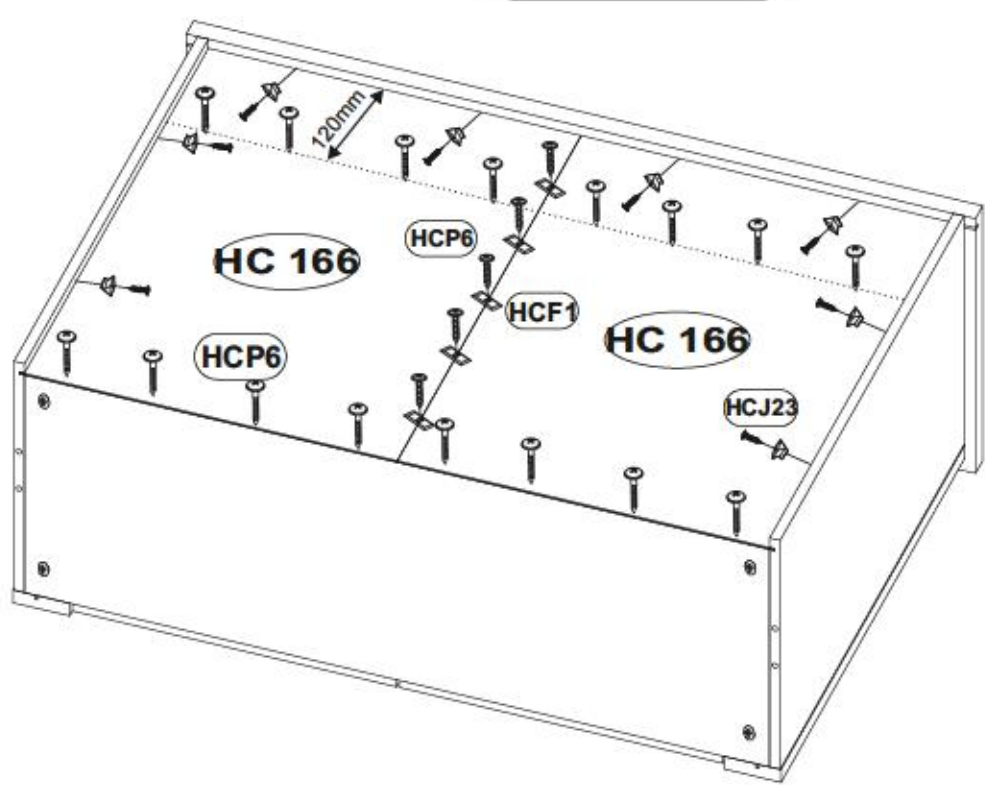
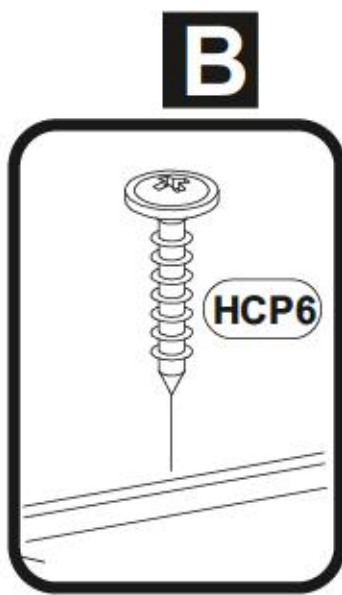
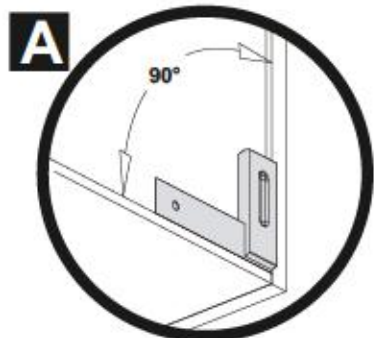

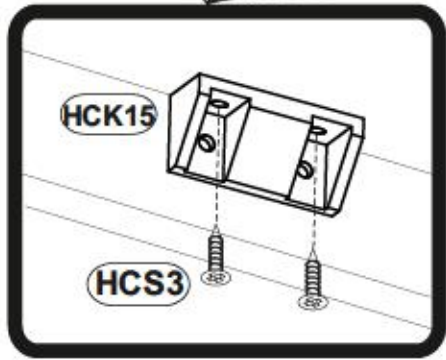
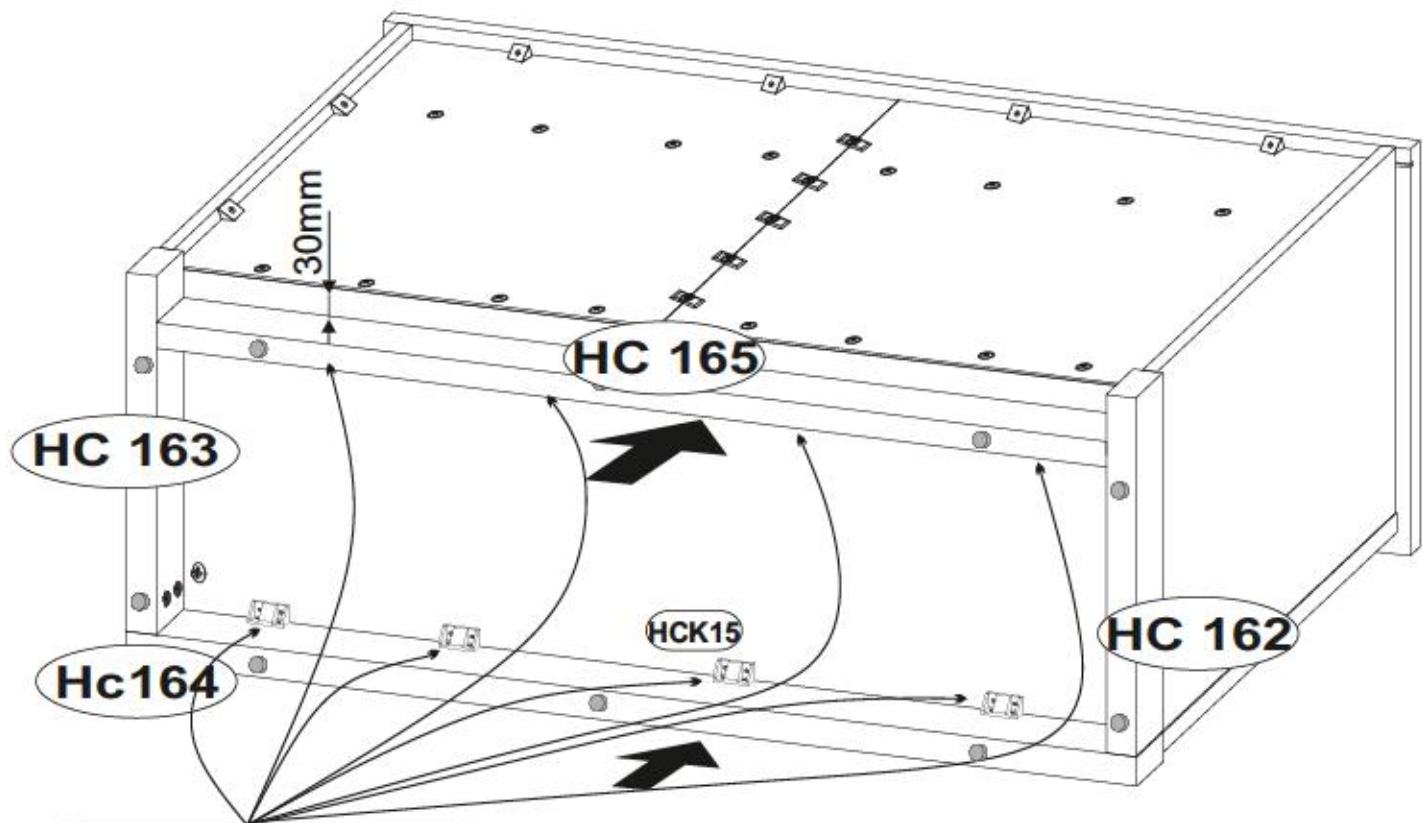

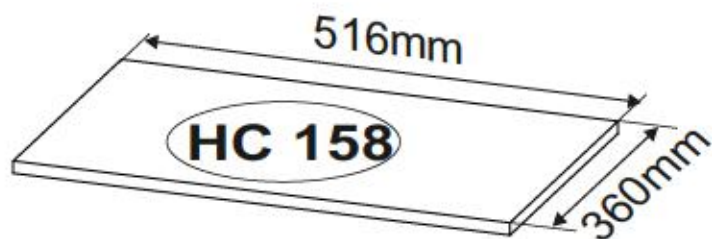
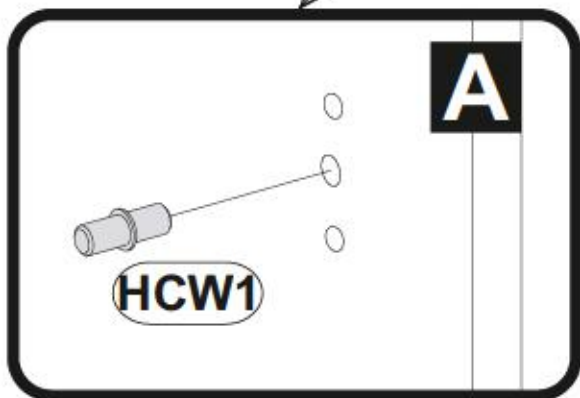
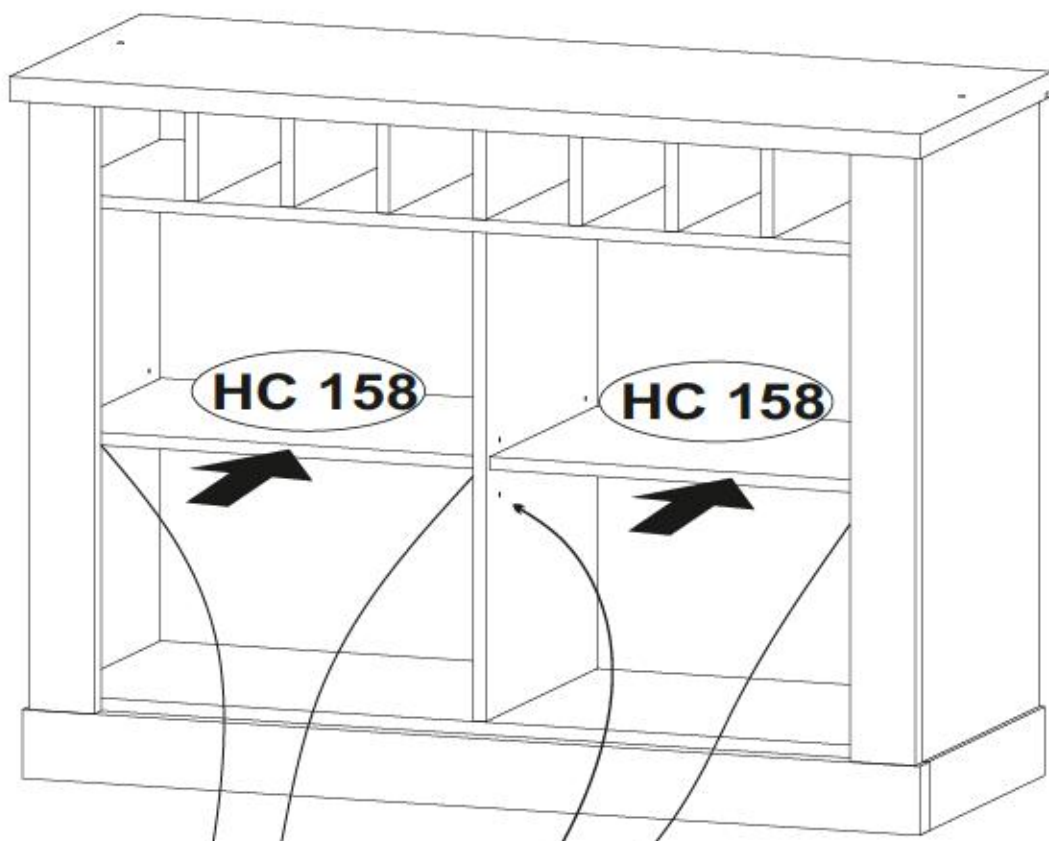

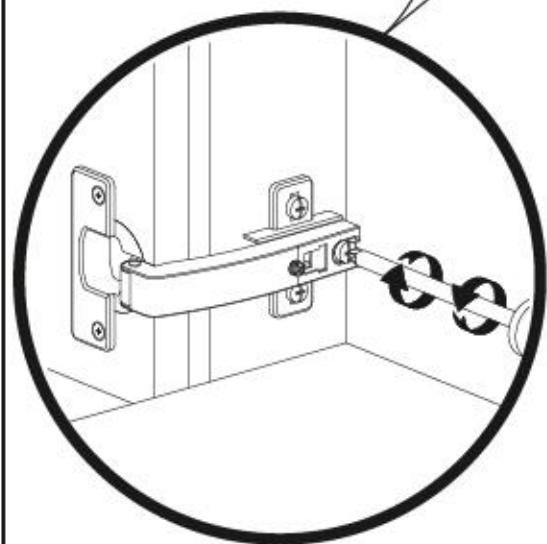
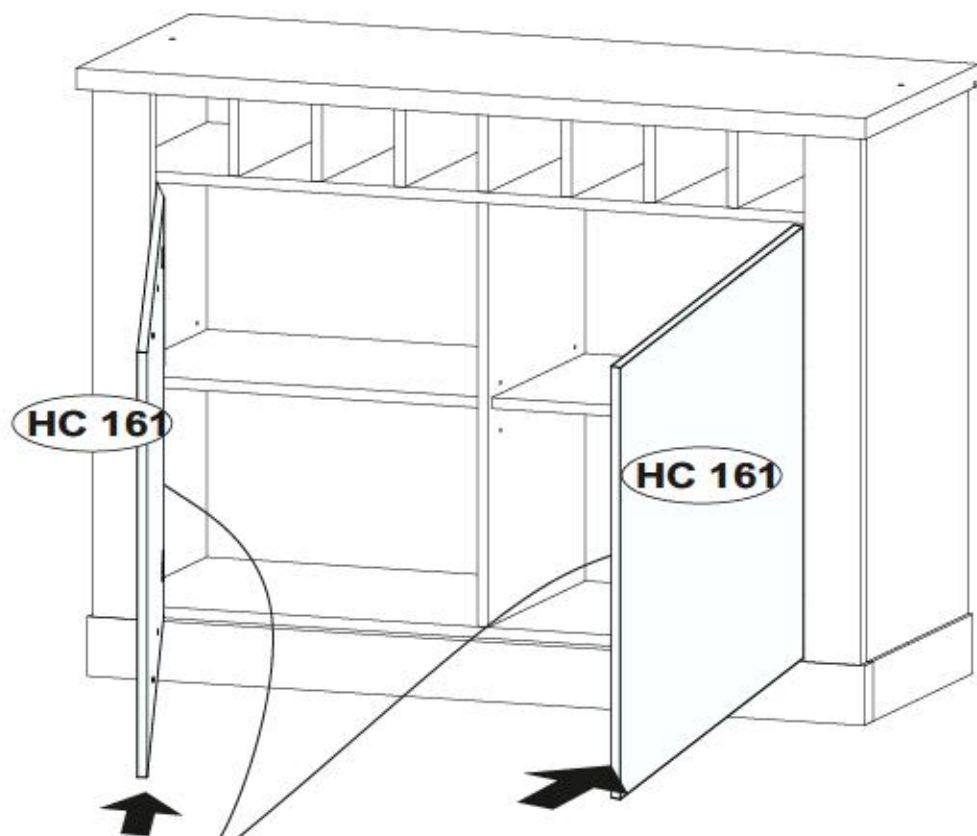

HCZ2 + HCD14

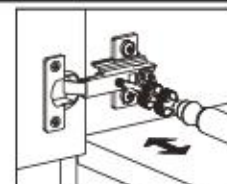
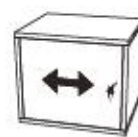
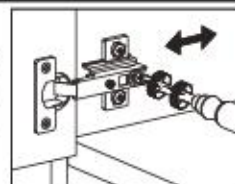
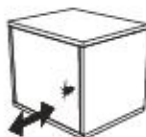
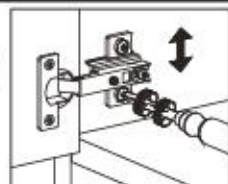
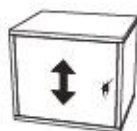

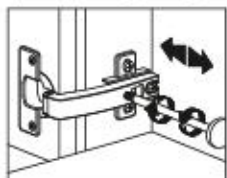
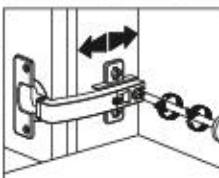
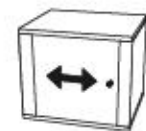
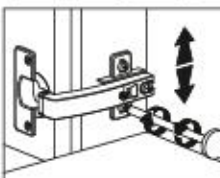
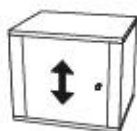

HCZ4 + HCD14

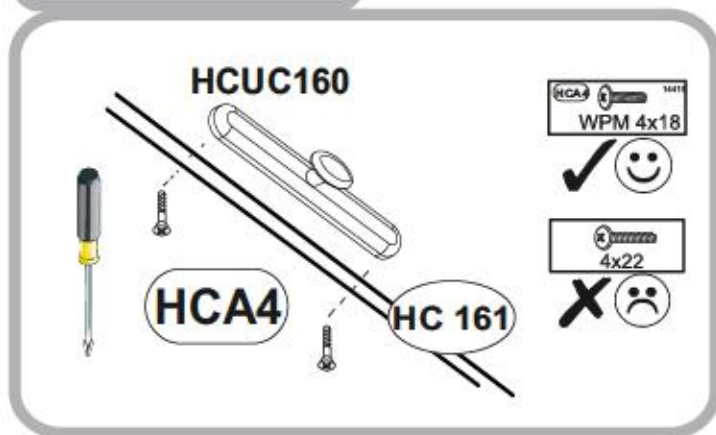
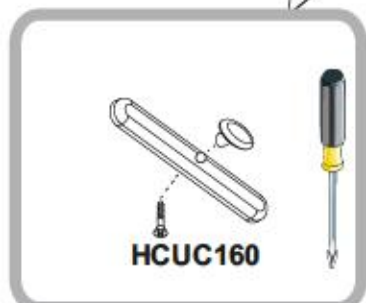
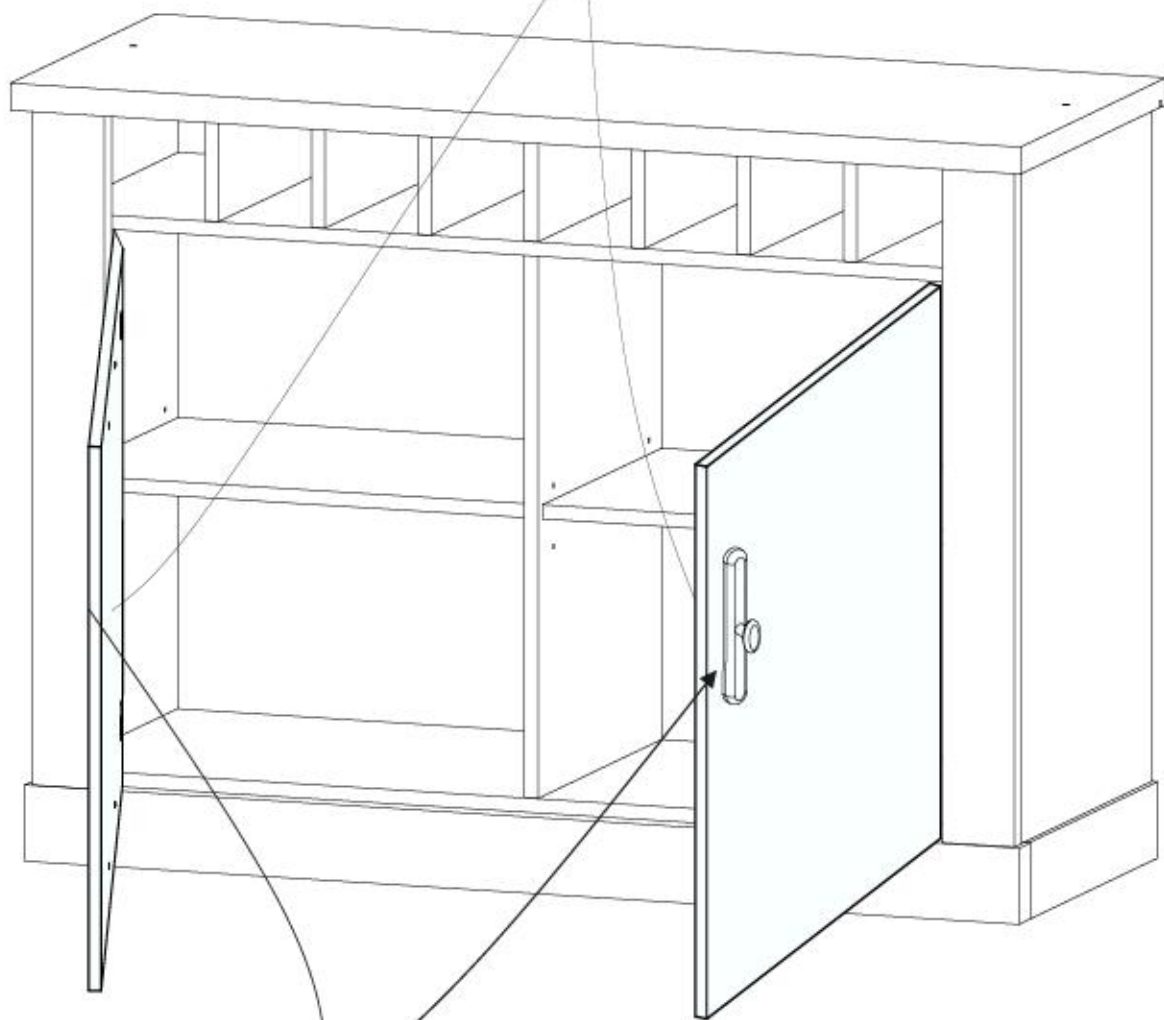
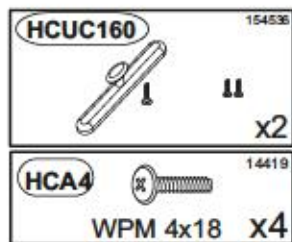
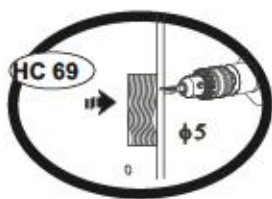





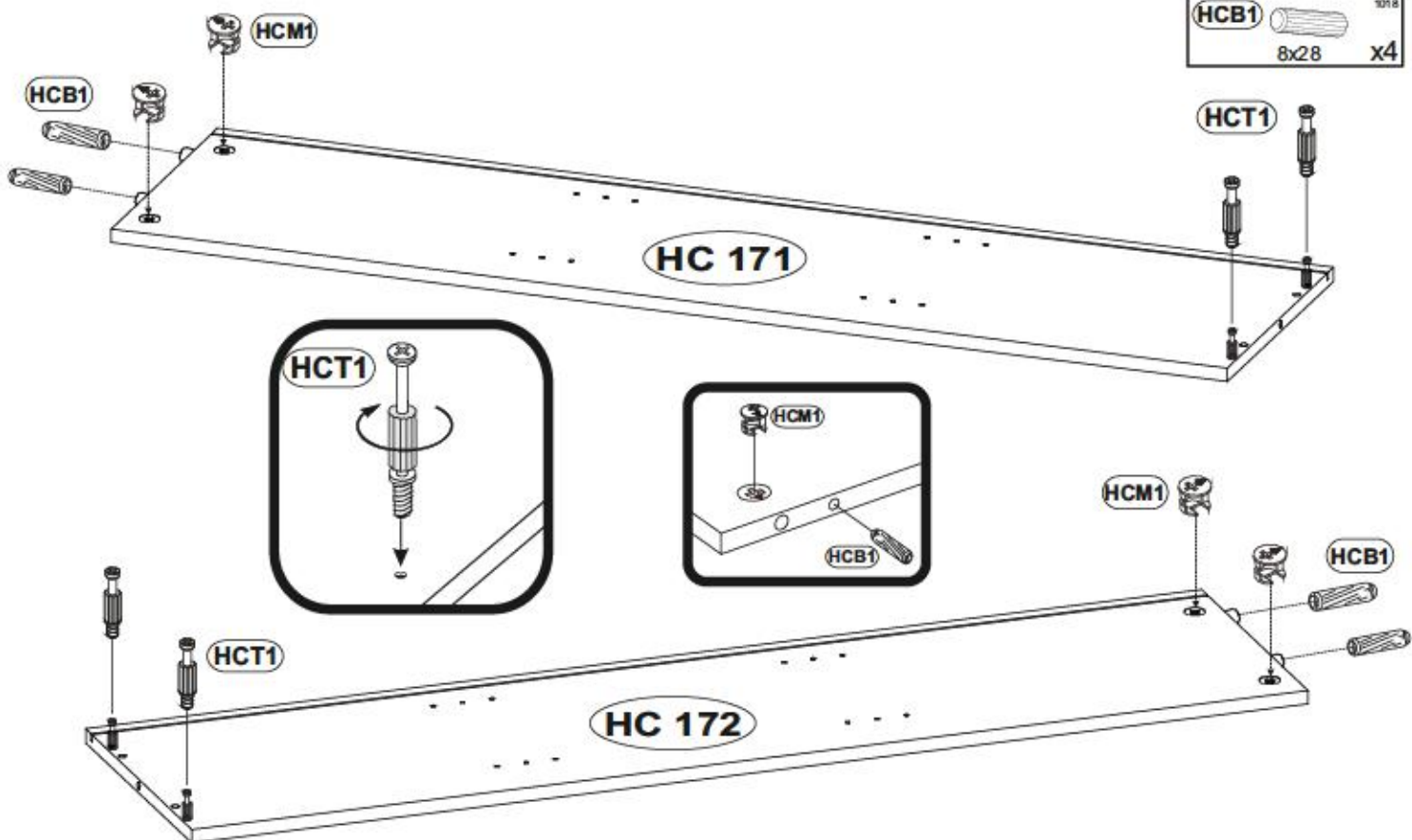

# 21

HCT1		11803
		x4
HCM1		123894
		x4
HCB1		1018
	8x28	x4



# 22

HCM1		123894
		x4
HCB1		1018
	8x28	x4

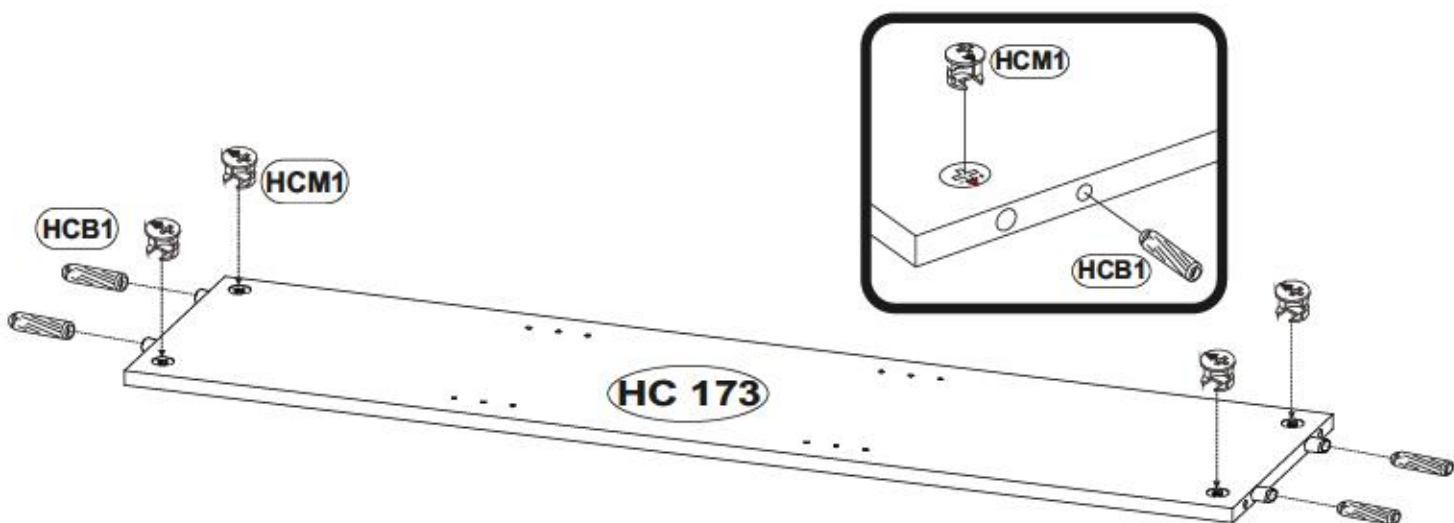

23

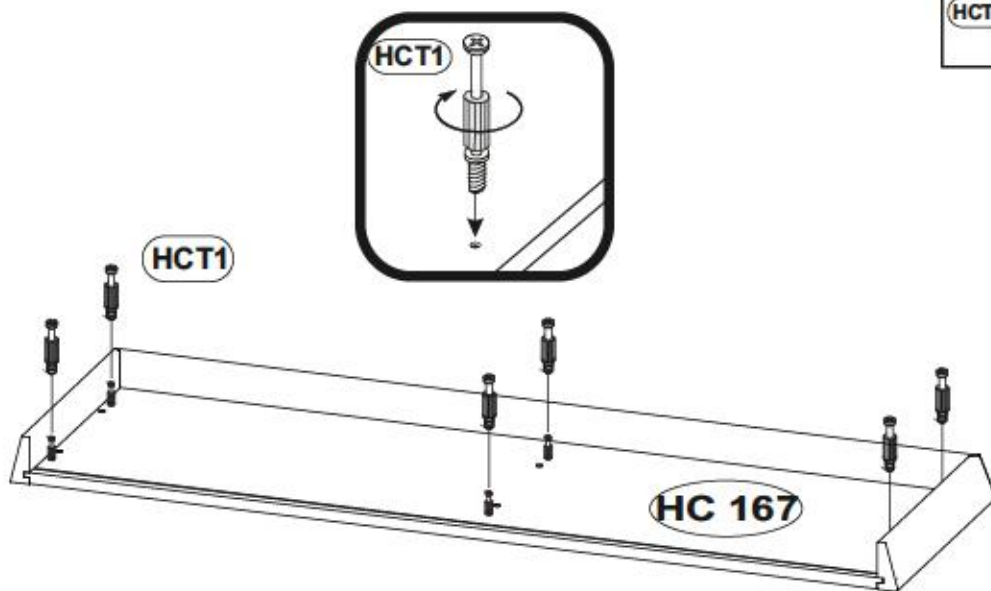
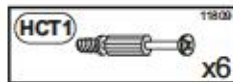

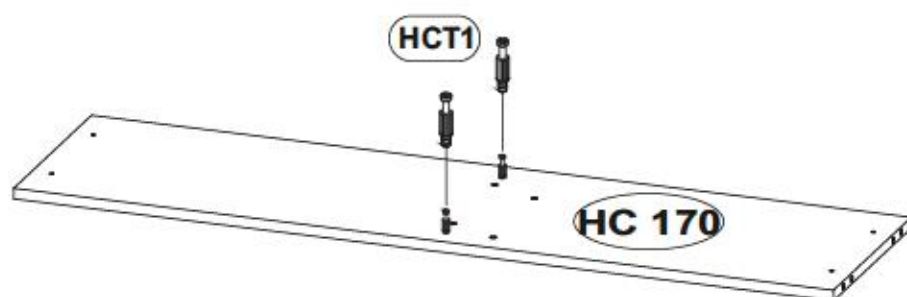
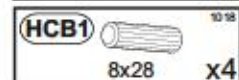

24

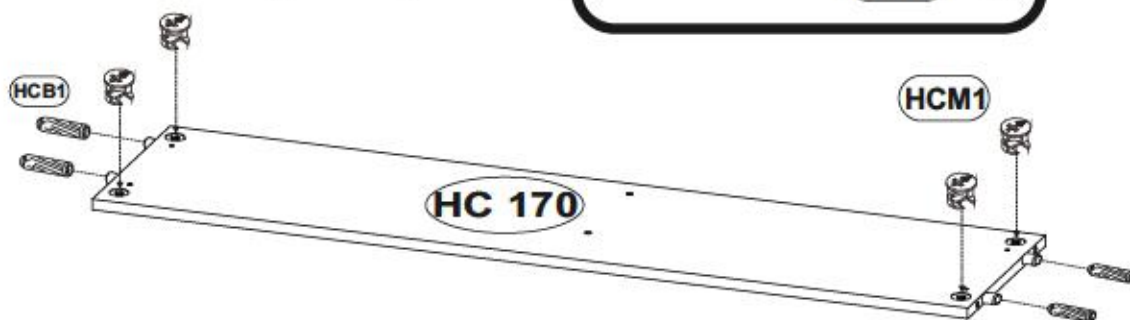
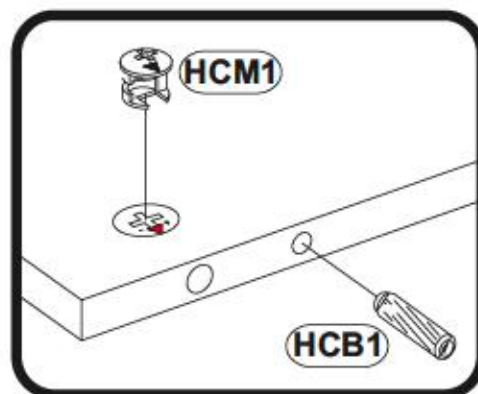

180°



HCK13		40718
		x8
HCS3		1011
	3,5x13	x16
HCD14		26618
	H4	x4

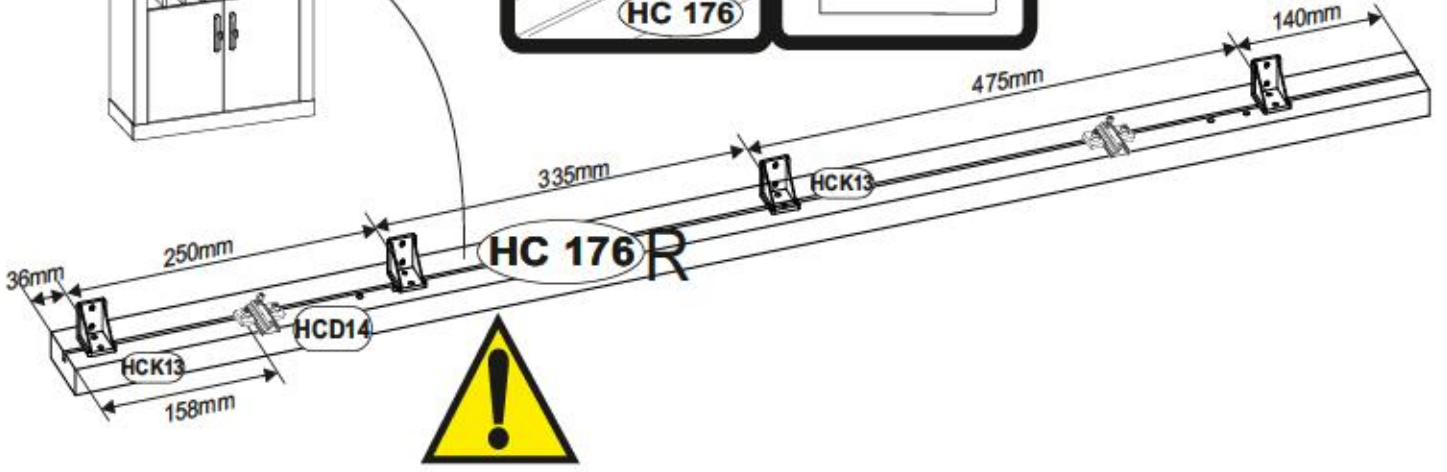
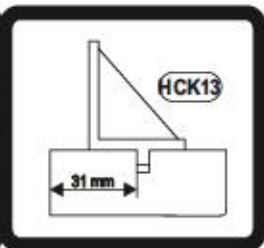
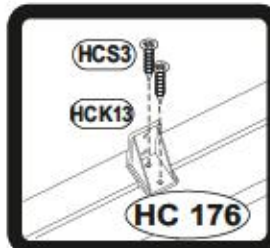
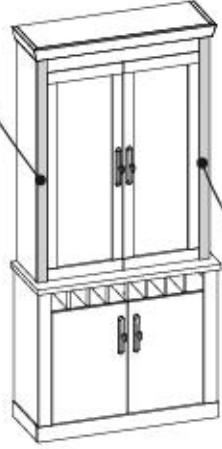
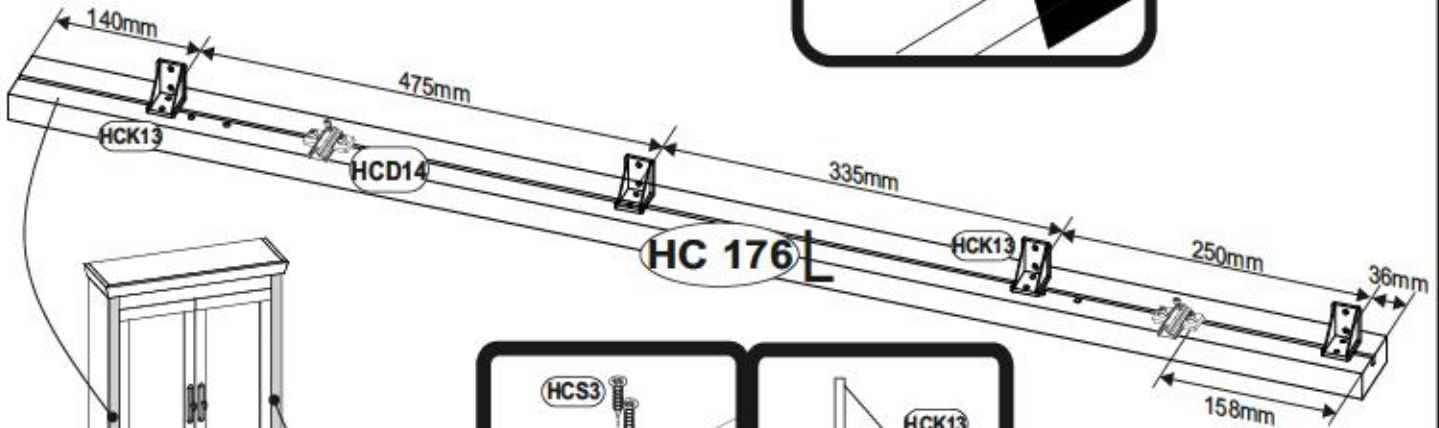
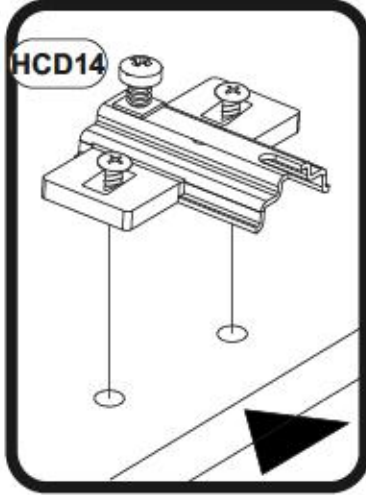

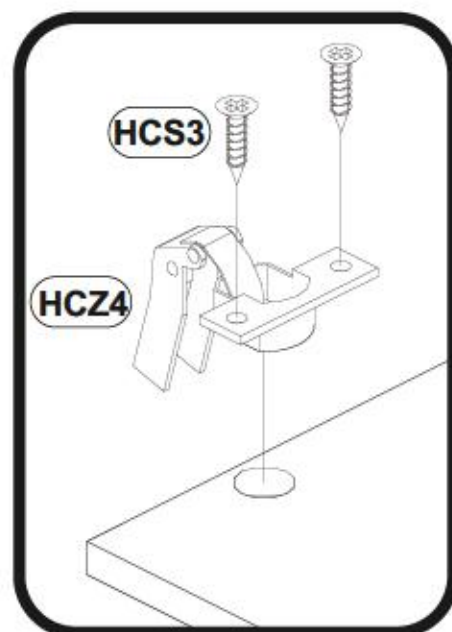
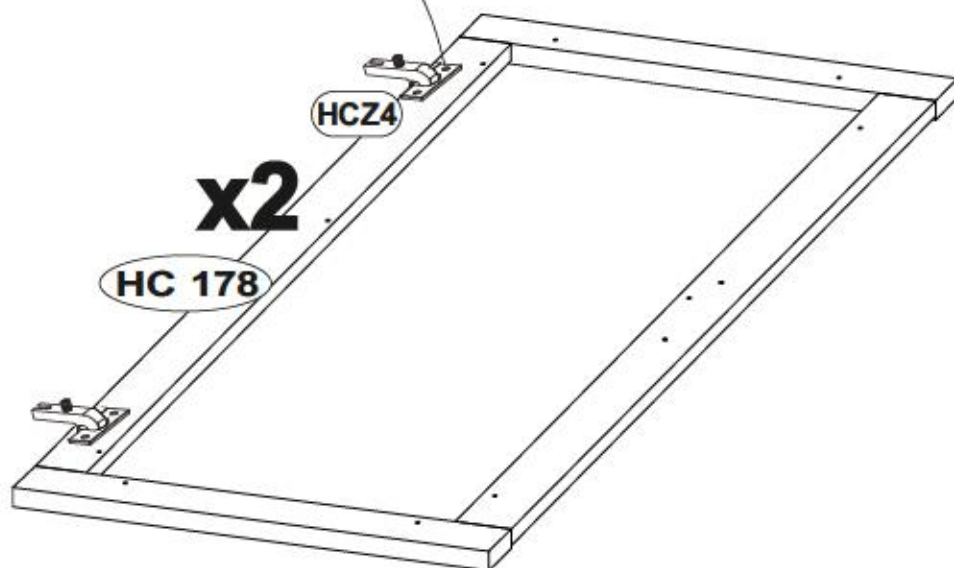
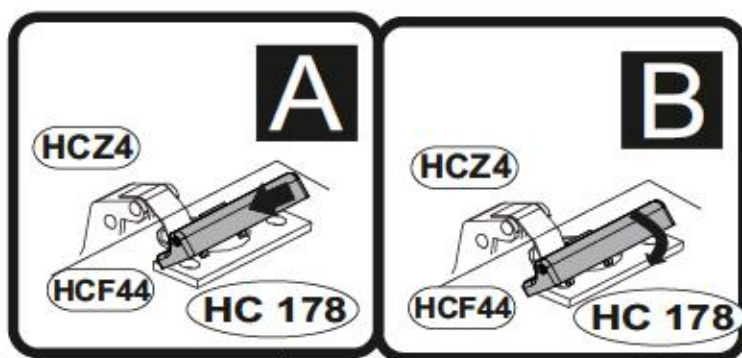
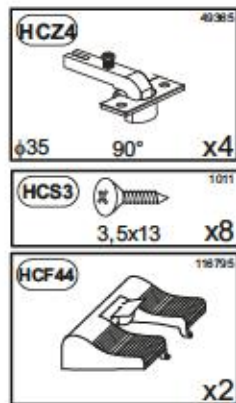

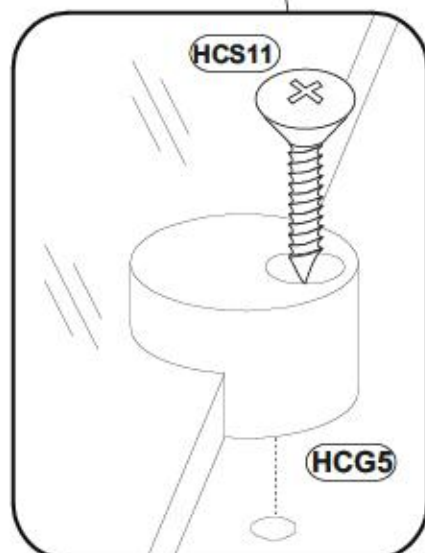
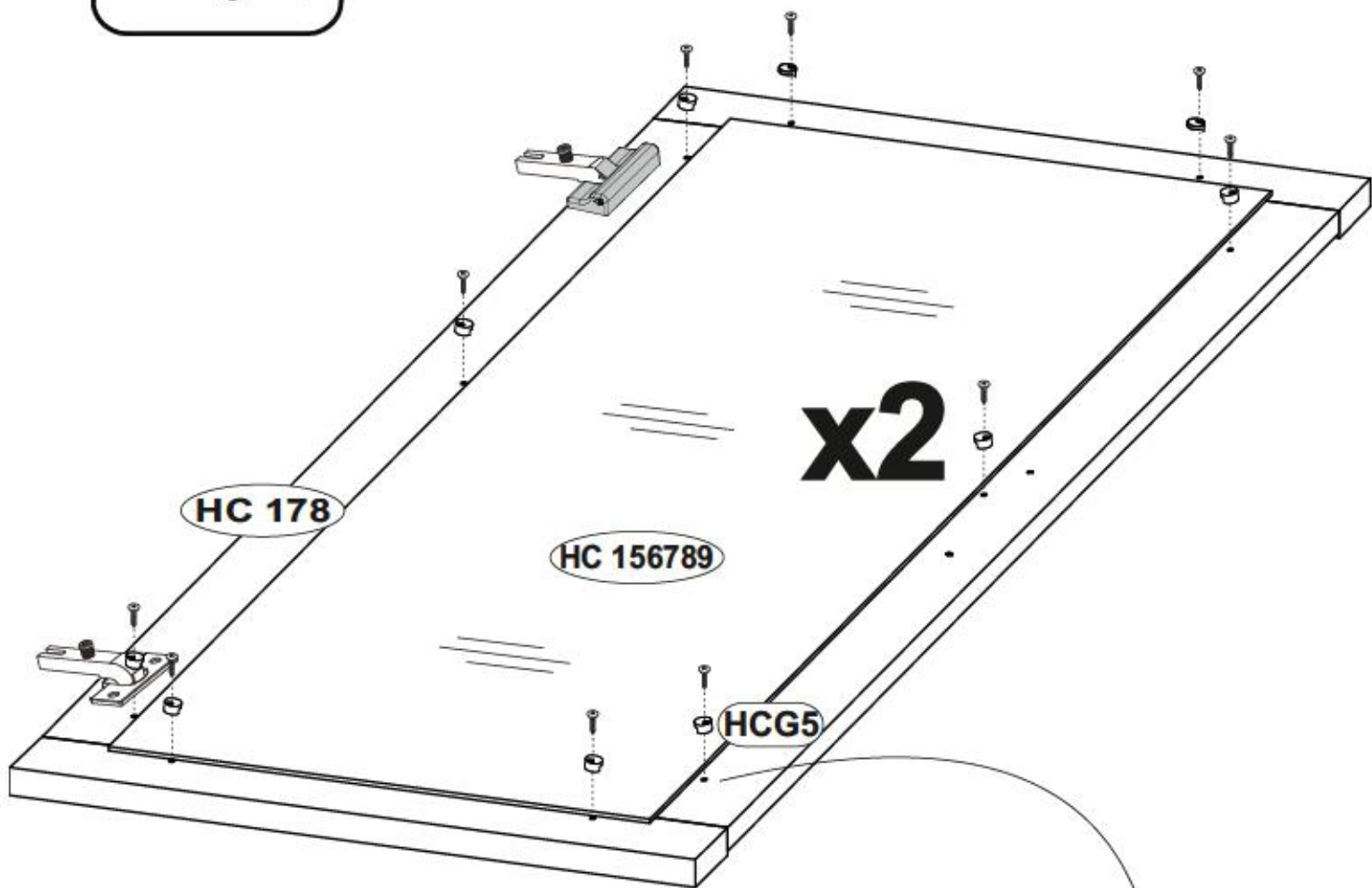



28

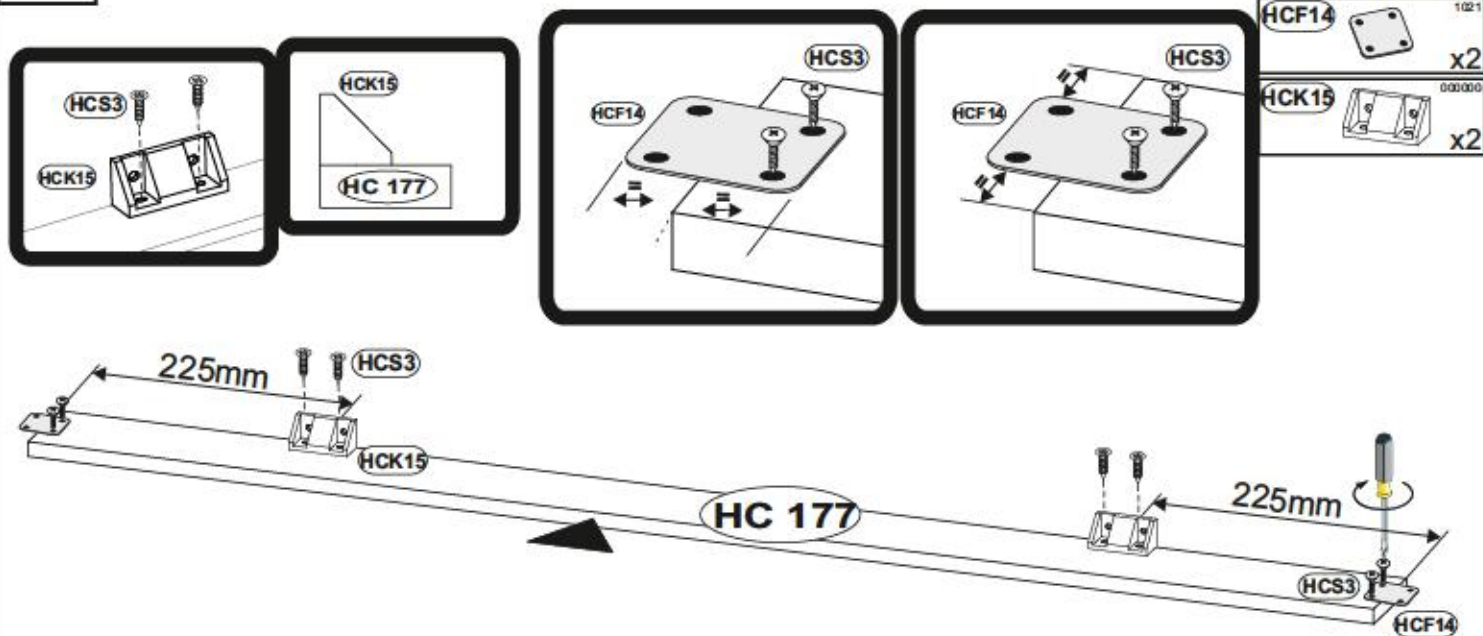

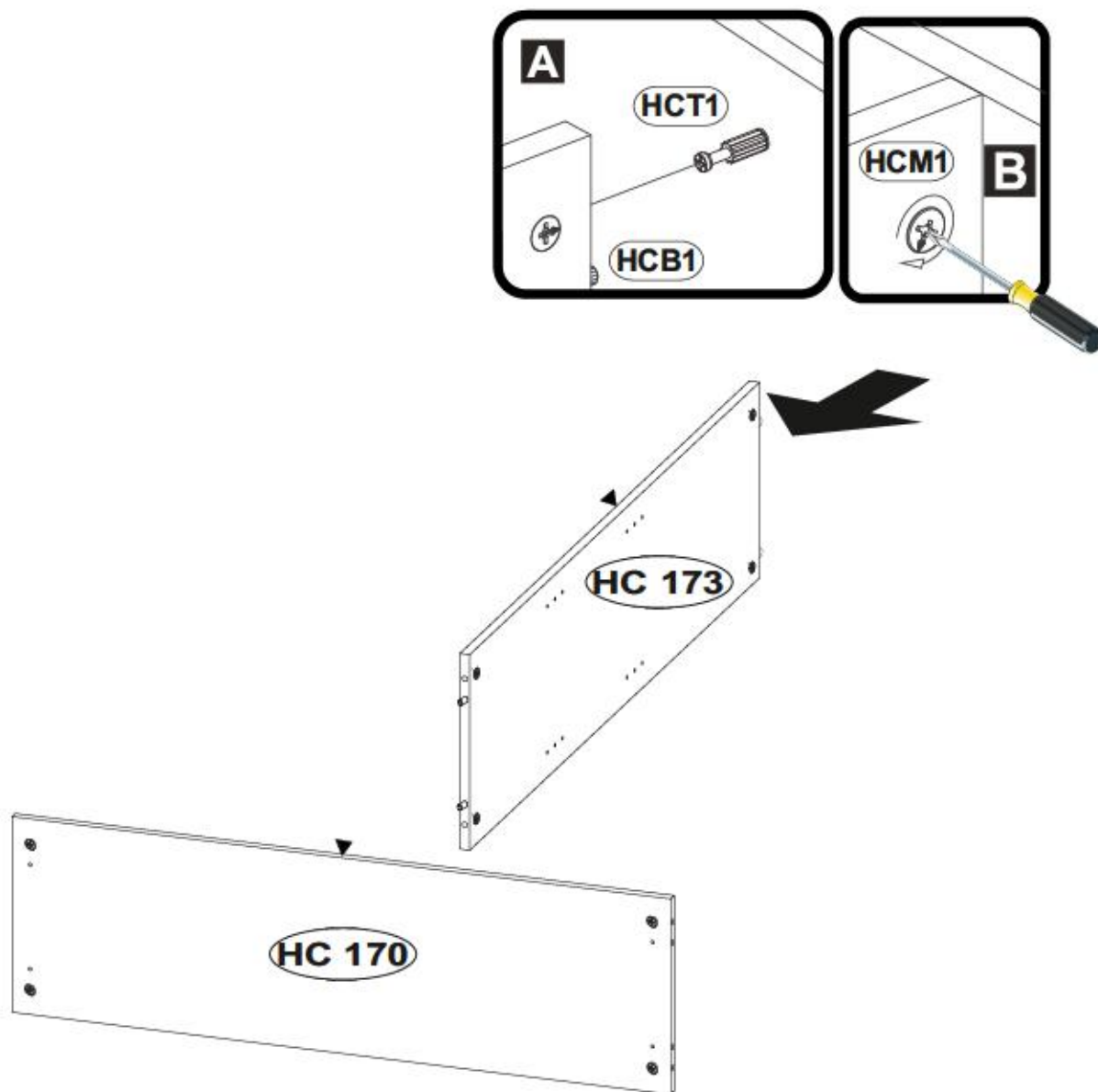

29

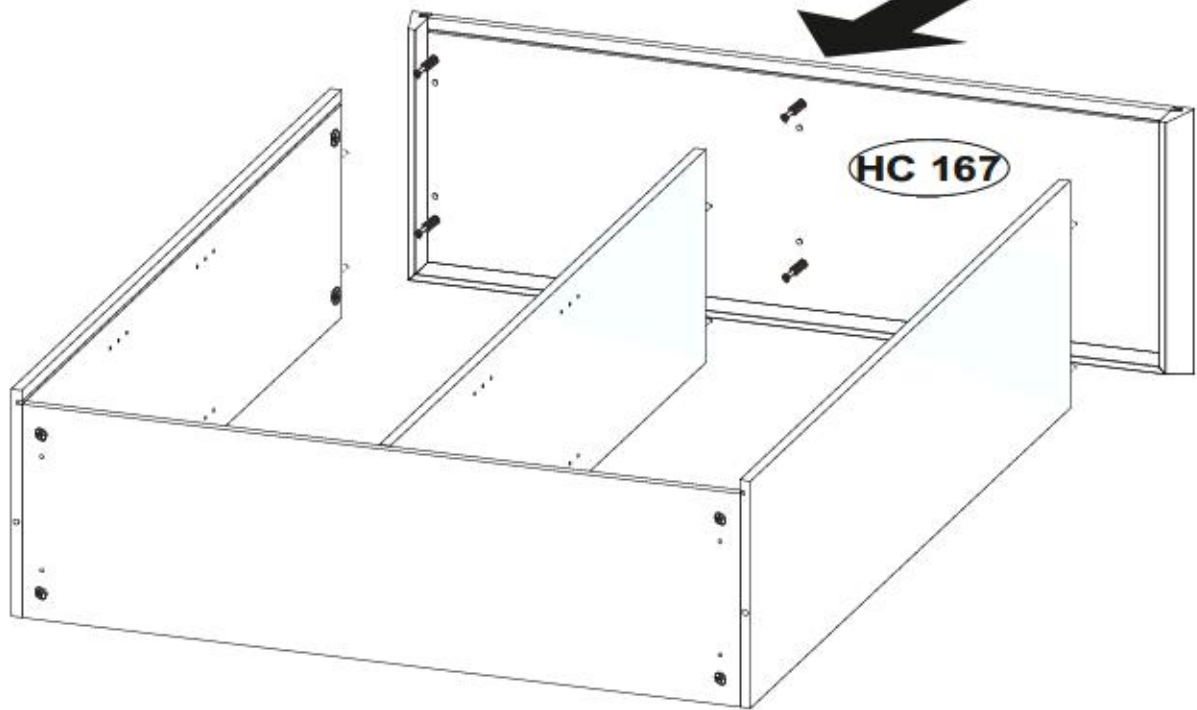
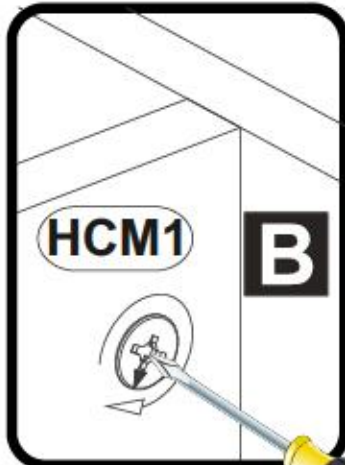
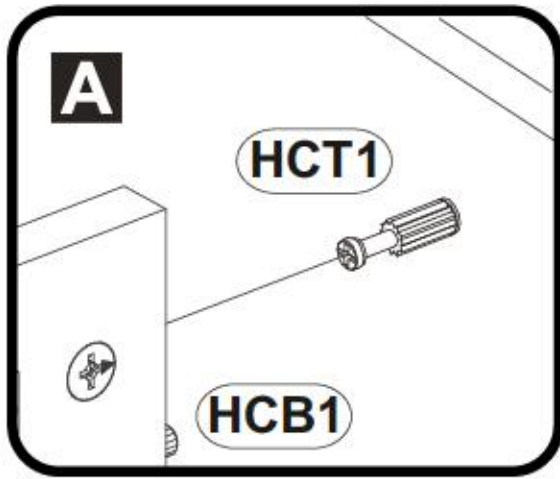
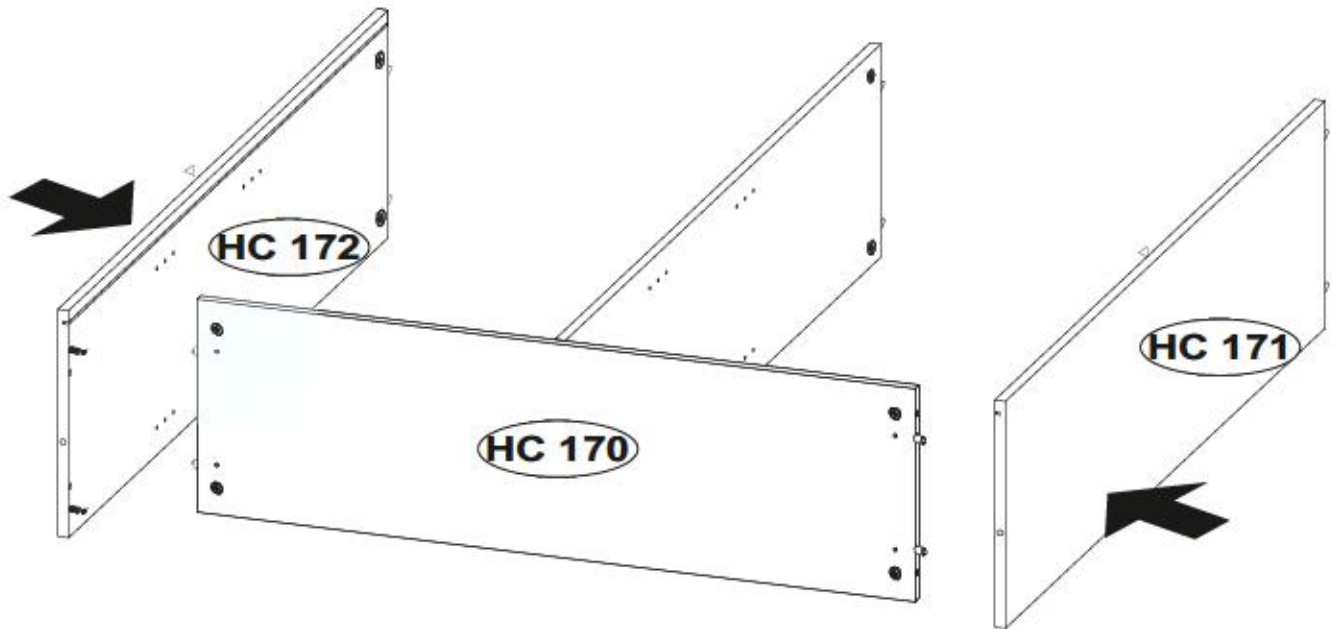

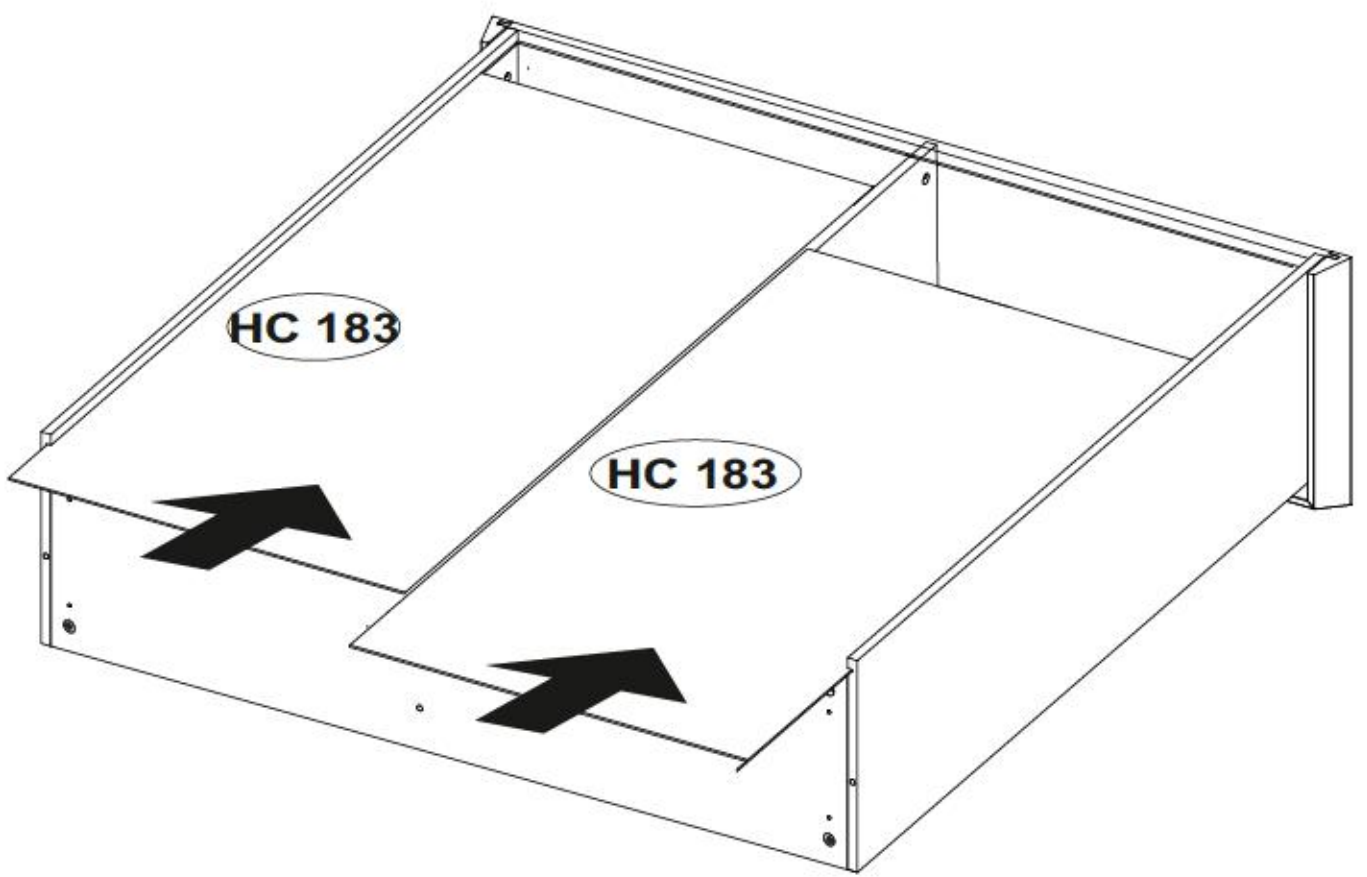



HCP6		1058
	3x20	x14
HCJ23		1302
		x12
HCF1		1415
		x6

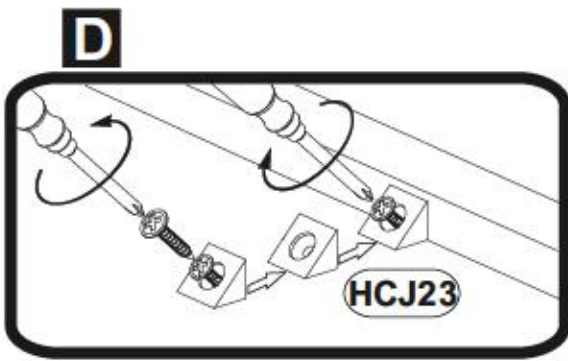
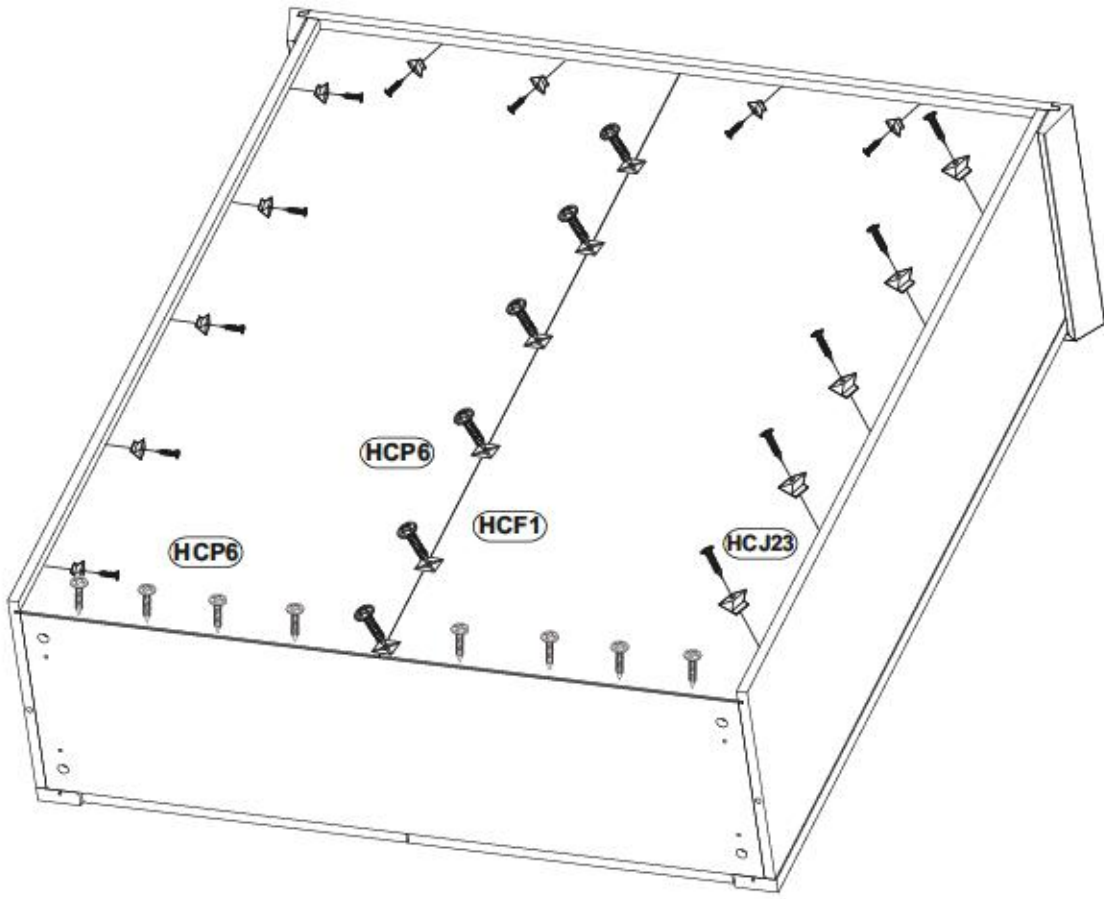
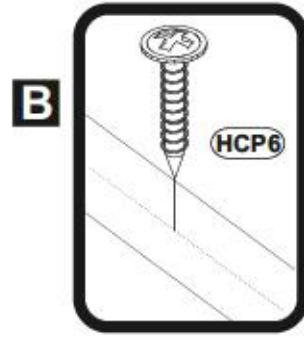
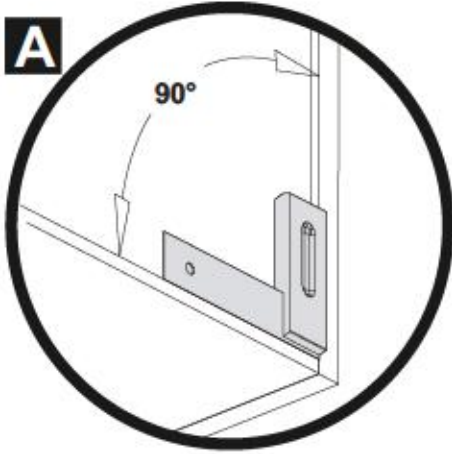

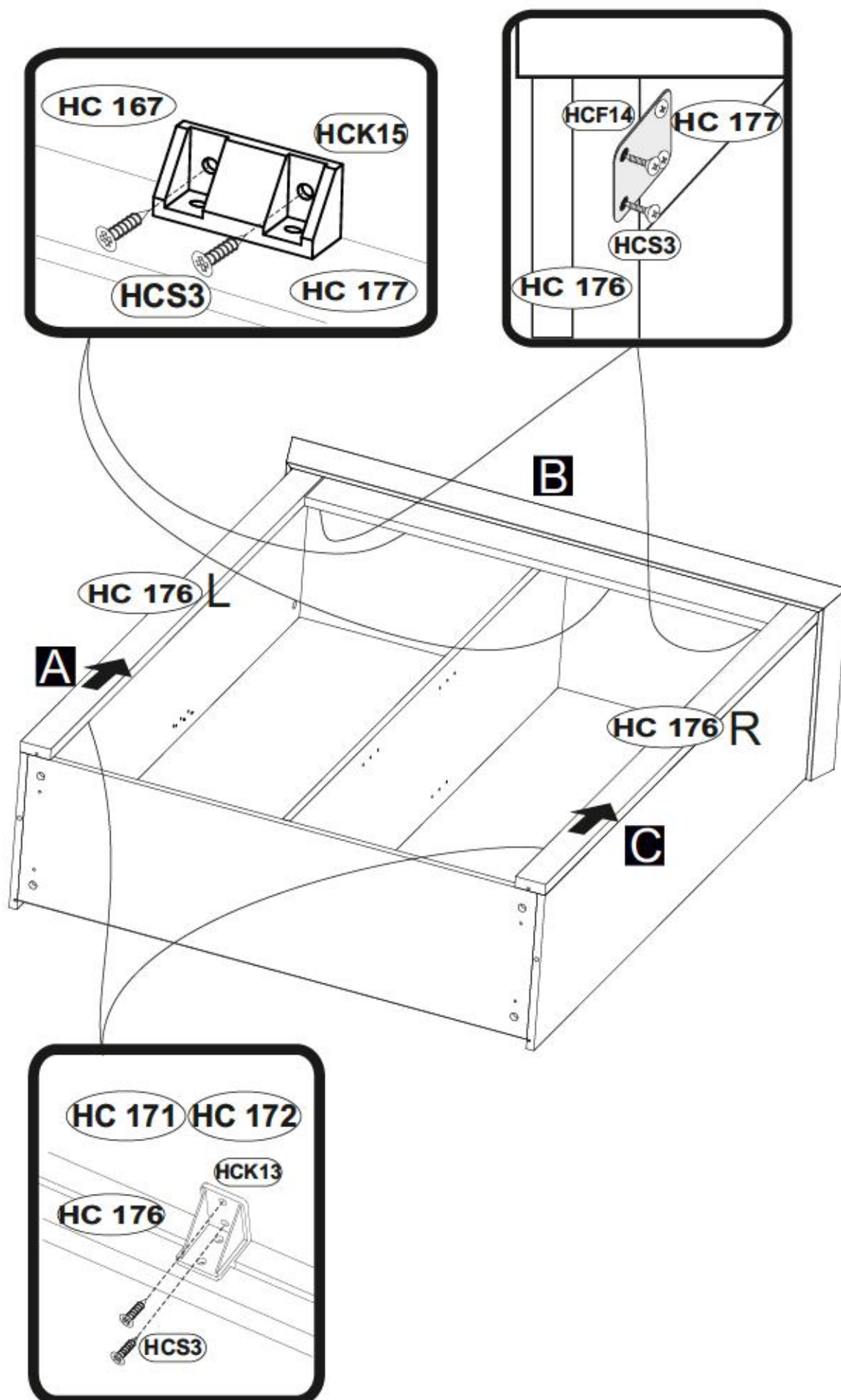



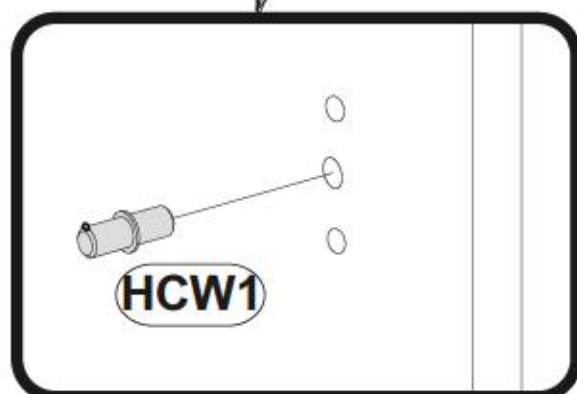
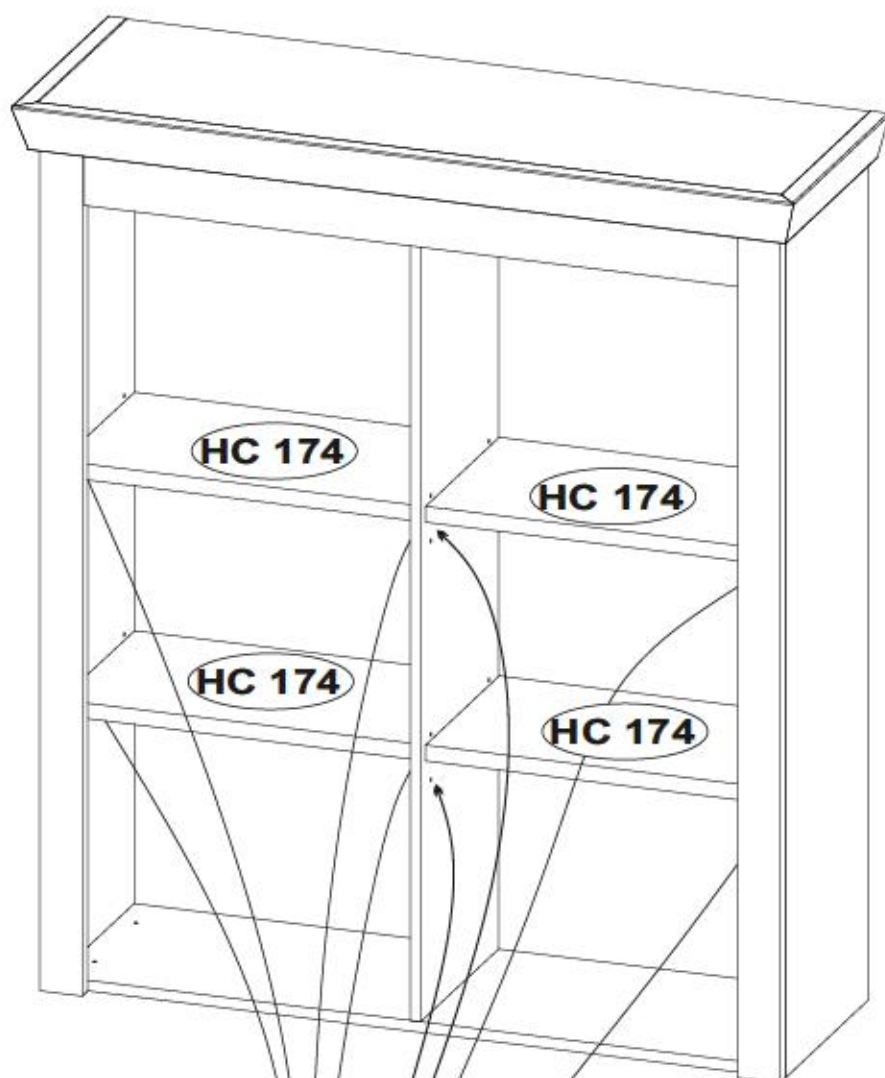



35

<b>HCUC160</b>		15433
	1	x2
<b>HCA4</b>		14419
	WPM 4x18	x4

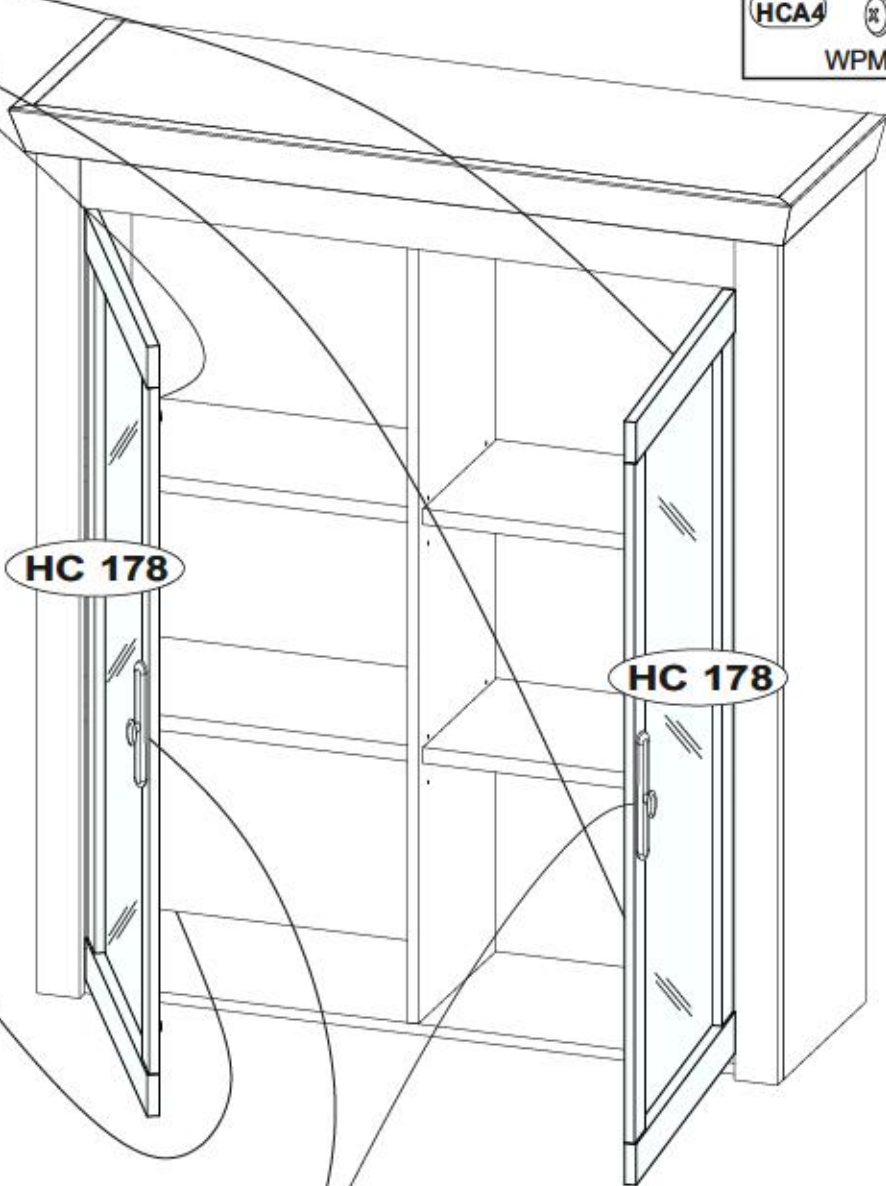
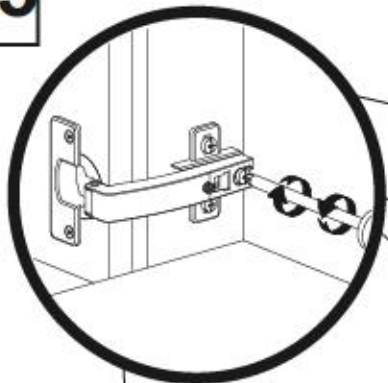

**A**

**HCUC160**

**HCUC160**

**HCA4**

**HC 178**

**WPM 4x18**

**4x22**

✓ ☺

✗ ☹

HCZA + HCD14

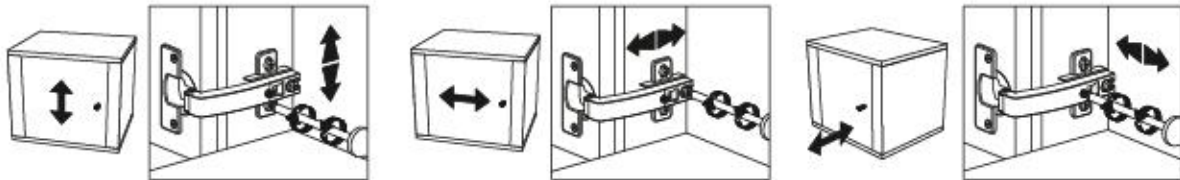

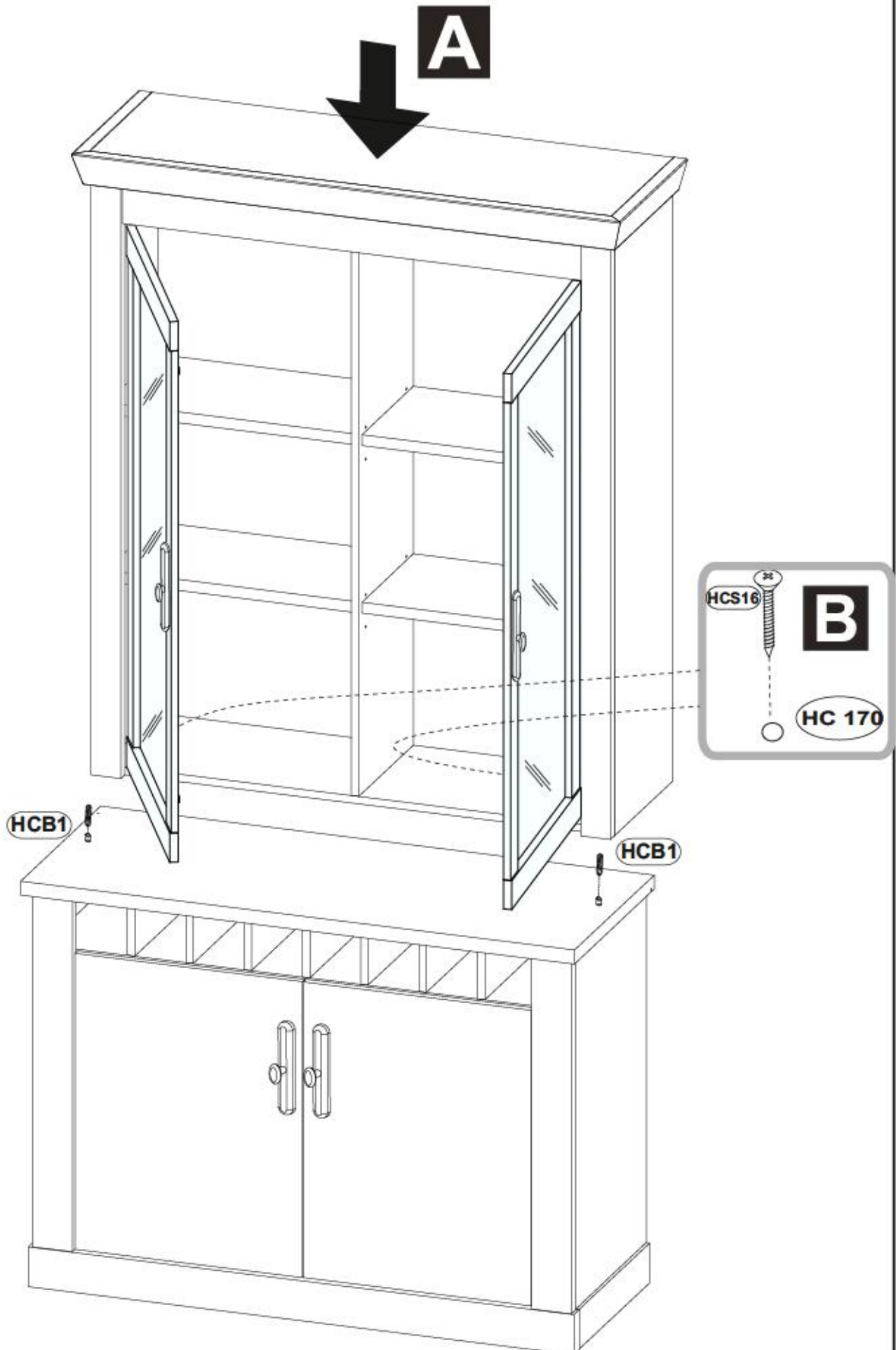
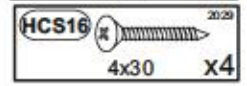
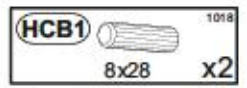

HCC6 140818  
 $\phi 20$  x24

HCCJ11 1267  
 x2

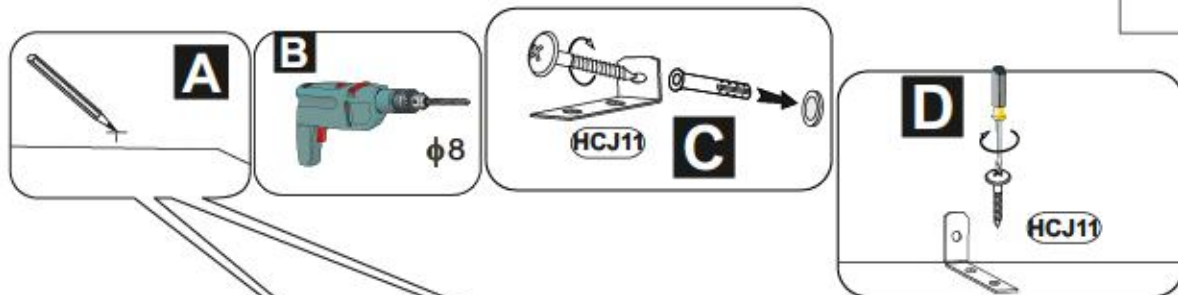

HC 167

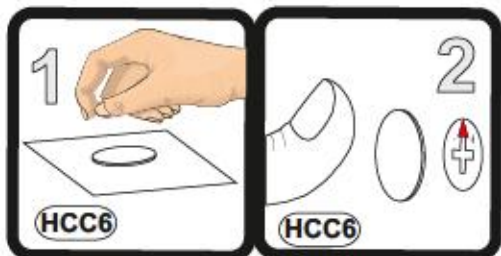
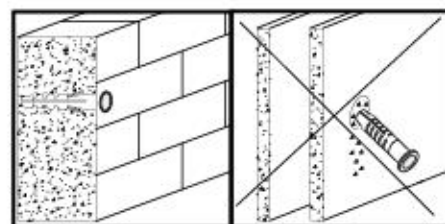
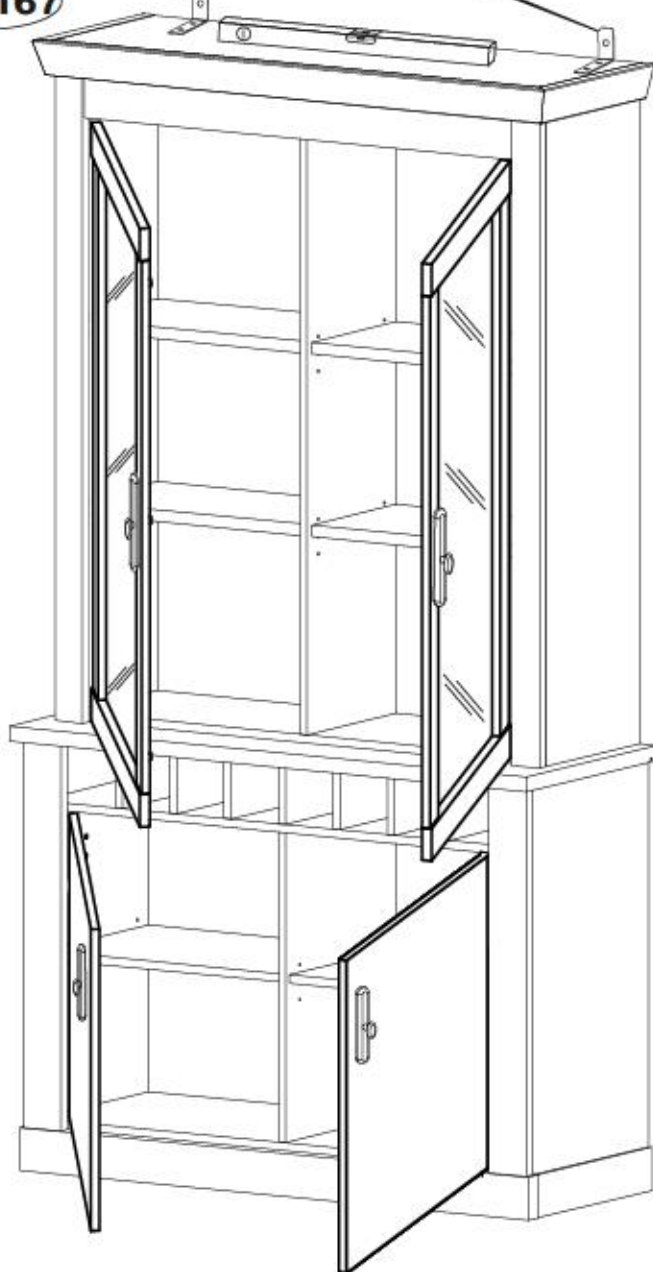



# RAVENNA 27

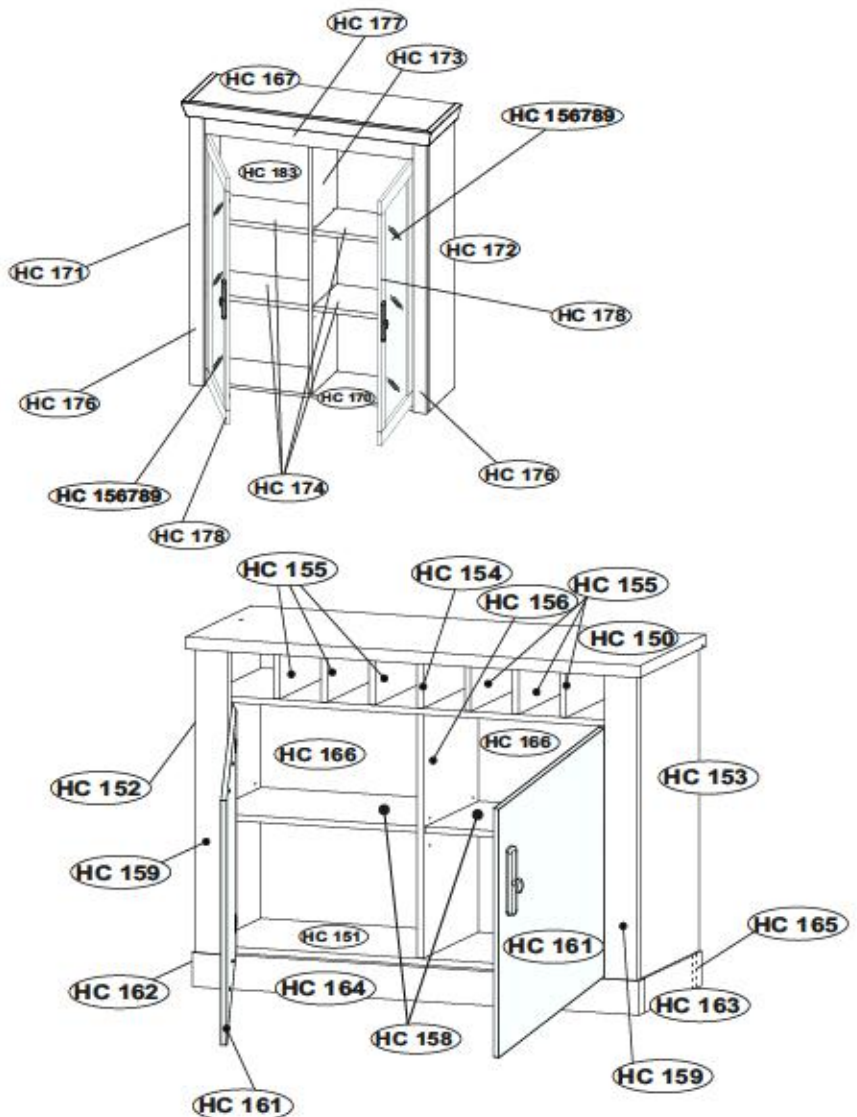

**D** Unser Kundenportal für Beschädigte  
Bitte Ihren ein Beschädigt haben, können Sie diese Servicekarte direkt an die Unreklamieren de Adresse mailen. Wir können Sie nur Beschädigte auf diesem Weg versenden. Sollten Sie eine andere Bezeichnung ein Item Möbelschaden haben, so werden sie sich bitte direkt an Ihr Möbelhaus.

**GB** Our direct order service for items  
If a fitting part is missing, you can e-mail this service card directly to the address below. However, we can only send fitting parts in this way. If you have any other cause for complaint concerning your item of furniture, please contact your furniture store directly.

**CZ** Než se přímé služby prokovali  
Chybí-li vám nějaká díl z kování, můžete tuto službu kartu odešlat e-mailem přímo na náš uvedenou adresu. Tuto službu však můžeme poskytnout jen díly kování. Pokud byste měli problém jiný díl nábytku, obraťte se přímo na svého prodejce nábytku.

**F** Service direct de votre cas de dommage  
Si vous manque une ferrure, vous pouvez envoyer directement la présente carte service à l'adresse e-mail indiquée ci-dessous. Cependant, nous ne pouvons uniquement émettre des ferrures. Pour tout autre type de réclamation concernant votre meuble, vous devez contacter directement votre magasin d'ameublement.

**I** Il nostro servizio diretto per l'ordine delle ferrature  
Qualora vi dovesse mancare un pezzo di ferraggio, allora vi preghiamo di inviare questa carta di servizio tramite e-mail all'indirizzo indicato. Possiamo inviare i pezzi di ferraggio solamente per mezzo di questo procedimento. Qualora dovete avere qualche altra reclamazione in merito al mobile, allora vi preghiamo di rivolgervi direttamente al Vostro Negozio di mobili.

**BG** Прямия директен услуга за облек  
Ако липне част от ковањето, можете директно да испратите сервисна карта или е-пошта на адрес, посочен по-долу. По този начин може да доставим само железни компоненти от облек. Ако искате да имате друга причина за жалба, въведете директно в фирмата или магазините за мебели, от който сте закупили стоката.

**NL** Onze direct dienst de voor case van schade  
Wanneer er een onderdeel ontbreekt, kunt u deze servicekaart direct aan onze adres e-mail baden sturen. Wij kunnen langa de we weg achter alleen beslagdelen versenden. Mocht u een ander probleem met uw meubel hebben, verzochten wij u contact op te nemen met uw meubel dealer.

**PL** Nasza bezplatna usługa serwisowa montażowych  
Jeżeli brakuje części kowalniczych do montażu, prosimy o przesłanie nam niniejszej karty serwisowej na nasz podany adres e-mailowy. W ten sposób możemy przesyłać wyłącznie elementy żelazne. W przypadku innych reklamacji prosimy o kontakt z naszymi sprzedawcami, w którym został dokonany zakup.

**HR** Servis za oštećenje  
U slučaju da nedostaje neki od dijelova molimo vas da nas dalje ne vodite mail adresu pošaljete ovaj servisni obrazac. Na ovaj način možemo dostaviti samo željezne dijelove. U slučaju da imate bilo kakav drugi problem molimo vas da se obratite izravno trgovini namještaja gdje je isti kupljen.

**HU** Díszközvetleni szolgálatunk a kovácsokhoz  
Ha hiányzik egy szelet, azt elküldhetjük közvetlenül a következő e-mail címre. Azonban csak a vasaljakat tudunk így küldeni. Amennyiben másfélajta problémát szeretne jelezni, forduljon közvetlenül a bolti eladóhoz.

**SK** Naše priamy servis pre škody kováčiek  
Ak Vám chýba niekedy časť kováčiek, môžete poslať túto službu kartu poslať e-mailom na náš uvedenú adresu. Dámy kováčiek vieme poslať iba týmto spôsobom. Ak by ste mali inú reklamáciu súvisiacu s Vaším nábytkom, obráťte sa priamo na Vašu predajňu nábytku.

**SLO** Než se přímé služby prokovali  
Chybí-li vám nějaká díl z kování, můžete tuto službu kartu odešlat e-mailem přímo na náš uvedenou adresu. Tuto službu však můžeme poskytnout jen díly kování. Pokud byste měli problém jiný díl nábytku, obraťte se přímo na svého prodejce nábytku.

**RO** Servis direct de la caz de daune  
In cazul in care va lipseste o piesa de fiermecie puteti sa trimbate direct o astfel de service prin e-mail la adresa de mai jos. Noi nu putem trimbate piesa de fiermecie decat pe o astfel de cale. Daca aveti o alta reclamatie in legatura la piesa de mobilier, atunci va rugam sa va adresati direct la magazinul dvs. de mobilier.

**RUS** Прямая директен услуга за облек  
Ако липне част от ковањето, можете директно да испратите сервисна карта или е-пошта на адрес, посочен по-долу. По този начин може да доставим само железни компоненти от облек. Ако искате да имате друга причина за жалба, въведете директно в фирмата или магазините за мебели, от който сте закупили стоката.

**S** Než se přímé služby prokovali  
Chybí-li vám nějaká díl z kování, můžete tuto službu kartu odešlat e-mailem přímo na náš uvedenou adresu. Tuto službu však můžeme poskytnout jen díly kování. Pokud byste měli problém jiný díl nábytku, obraťte se přímo na svého prodejce nábytku.

**ES** Nuestro servicio directo para daños  
Si le falta alguna pieza de herrajería, puede enviar esta tarjeta de servicio directamente a la siguiente dirección. No obstante, por este método solo podemos enviar accesorios. Si tiene alguna otra objeción sobre su mueble, consulte directamente con su mueblaría.











**TR** Doğrudan hizmet için hasar kartı  
Bir demir aksesuarınızın parçası yoksa, bu kartı doğrudan aşağıdaki e-posta adresine gönderebilirsiniz. Ancak sadece demir aksesuarları bu şekilde gönderebiliriz. Mobilyanızla ilgili diğer problemleriniz varsa lütfen doğrudan mobilya satıcınıza danışın.

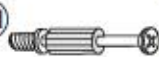



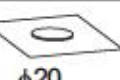

HC 150	x1	1111	440	28	2/3
HC 151	x1	1049	375	15	3/3
HC 152	x1	711	395	15	1/3
HC 153	x1	711	395	15	1/3
HC 154	x1	112	373	15	2/3
HC 155	x6	112	373	15	2/3
HC 156	x1	569	373	15	3/3
HC 157	x1	1049	374	15	3/3
HC 158	x2	516	360	15	3/3
HC 159	x2	711	80	22	1/3
HC 161	X2	593	456	15	2/3
HC 162	x1	392	80	28	2/3
HC 163	x1	392	80	28	2/3
HC 164	X1	1094	80	28	1/3
HC 165	x1	1036	80	28	2/3
HC 166	x2	716	530	2.5	1/3



HC 167	x1	1102	371	65	1/3
HC 170	x1	1011	300	15	1/3
HC 171	x1	1236	320	15	3/3
HC 172	x1	1236	320	15	3/3
HC 173	x1	1221	300	15	3/3
HC 174	x4	497	273	22	1/3
HC 176	x2	1236	60	22	1/3
HC 177	x1	921	124	18	2/3
HC 178	x2	1106	456	18	2/3
HC 183	x2	1240	511	2.5	1/3
HC 156789	x2	1016	366	4	2/3

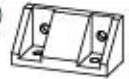
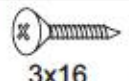

# RAVENNA 27

<b>HCB1</b>		1018
	8x28	X...
<b>HCM1</b>		123894
		X...
<b>HCT1</b>		11809
		X...
<b>HCJ23</b>		1302
		X...
<b>HCF14</b>		1021
		X...
<b>HCF36</b>		1305
		X...
<b>HCC6</b>		140318
	φ20	X...
<b>HCUC160</b>		154830
		X...
<b>HCW1</b>		1289
		X...
<b>HCG5</b>		1358
		X...

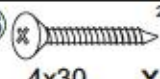
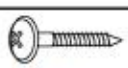
<b>HCD14</b>		23515
	H4	X...
<b>HCZ4</b>		49365
	φ35 90°	X...
<b>HCK15</b>		81556
		X...
<b>HCS11</b>		1073
	3x16	X...
<b>HCF44</b>		116795
		X...
<b>HCJ11</b>		1287
		X...
<b>HCA4</b>		14419
	WPM 4x18	X...

<b>HCK13</b>		49716
		X...
<b>HCS16</b>		2029
	4x30	X...
<b>HCP6</b>		1058
	3x20	X...
<b>HCF1</b>		1415
		X...
<b>HCS3</b>		1011
	3,5x13	X...

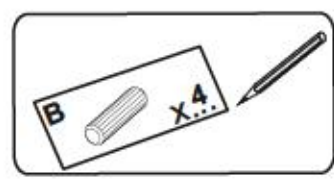

**D** Unser Direktendienst für Beschädigte  
 Sollte Ihnen ein Beschädigtes fallen, können Sie dieses Servicecenter direkt an die untenstehende Adresse melden. Wir können allerdings nur Beschädigte auf diesem Wege verschicken. Sollten Sie eine andere Beauftragung an Ihrem Möbelstück haben, so werden sie sich bitte direkt an Ihr Möbelhaus.

**GB** Our direct order service for fitting  
 If a fitting part is missing, you can e-mail this service card directly to the address below. However, we can only send fitting parts in this way. If you have any other cause for complaint concerning your item of furniture, please contact your furniture store directly.

**CZ** Naše přímé služby pro montáž  
 Chybí-li vám nějaký díl z kování, můžete tuto službu využít také e-mailem přímo na níže uvedenou adresu. Tuto částku však můžeme poslat jen tímto způsobem. Pokud byste měli nějaký jiný důvod, obraťte se přímo na svého prodejce nábytku.

**F** Service direct de montage  
 Si vous manquez une ferrure, vous pouvez envoyer directement la présente carte service à l'adresse ci-dessous. Cependant, nous ne pouvons vous fournir que des ferrures de montage par ce moyen. Pour tout autre type de réclamation concernant votre meuble, veuillez contacter directement votre magasin d'ameublement.

**I** Il nostro servizio diretto per l'ordine delle ferramenta  
 Qualora vi dovesse mancare un pezzo di fissaggio, allora vi preghiamo di inviare questa carta di servizio (tramite la presente all'indirizzo sottostante). Possiamo inviare i pezzi di fissaggio solamente per mezzo di questo procedimento. Qualora dovete avere qualche altra richiesta in merito al mobile, allora vi preghiamo di rivolgervi direttamente al Vostro Negozio di mobili.

**BG** Прямия директен уреден за обзавеждане  
 Ако липсва част от кованата, попълнената информацията свържете картата или изпратете на е-мил на адреса, посочен по-долу. По този начин можем да доставим само железни компоненти от обзавеждане. Ако искате да направим друга по-важна, въвеждаме директно обзавеждане или обзавеждане съществено, отидете директно в магазина.

**NL** Onze direct dienst de voor onze dienstverlening  
 Wanneer er een onderdeel ontbreekt, kunt u deze servicekaart direct aan onze dienst e-mailadres sturen. Wij kunnen langzamerhand wel achter alle benodigde onderdelen. Mocht u een ander probleem met uw meubel hebben, verzeeiken wij u contact op te nemen met uw meubeldealer.

**PL** Nasza bezpośrednia usługa serwisowa montażowa  
 Jeżeli brakuje części kowanych do montażu, prosimy o przesłanie nam niniejszej karty serwisowej na poniższy adres e-mailowy. W ten sposób możemy przesyłać wyłącznie tylko kowane części. W przypadku innych reklamacji dotyczących mebla, prosimy zgłosić się bezpośrednio do naszego sklepu, w którym został dokonany zakup.

**HR** Servis za obzave  
 U slučaju da nedostaje neki od dijelova molimo vas da ne šalje nevezano mail adresu navedenog ovog servisa obzave. Na ovaj način možemo dostaviti samo kovanice. U slučaju da imate dodatne prigovore vezane uz lemlu namještaja molimo vas da se obratite izravno trgovini namještaja gdje je isti kupljen.

**HU** Közvetlen szolgáltatás kovácsolt alkatrészekre  
 Ha hiányzik egy csavar, szelvény, kovácsolt alkatrész, akkor ezt az alkatrészt küldje el az alábbi e-mail címre. Azonban csak a kovácsolt alkatrészeket tudunk így küldeni. Amennyiben másféle probléma merül fel, forduljon közvetlenül a bolti kereskedőhöz.

**SK** Naše přímé služby pro montáž kování  
 Ak by Vám chýbala nejaká časť kování, môžete prostredníctvom služby využít e-mailom na nižšie uvedenú adresu. Týmto spôsobom však môžeme poslať iba kované diely. Ak máte inú príčinu sťažnosti, obráťte sa priamo na Vašu predajňu nábytku.

**SLO** Naše direktno službovanje za montažo kovanice  
 Če vam manjka kakšna kovanica, lahko to storite kar po elektronski pošti na spodnji mailovi. Po to način lahko pošljemo samo kovanice. Če želite imeti kakšno drugo težavo, se obrnite neposredno na vašo trgovino pohištva.

**RO** Serviciul nostru direct pentru fierare  
 În cazul în care vă lipsește o piesă de fierare puteți să trimiteți direct această card de service prin e-mail la adresa de mai jos. Noi nu putem să trimitem decât piese de fierare prin acest fel de comunicare.  
 Dacă aveți o altă reclamație referitoare la piesa de mobilier, atunci vă rugăm să vă adresați direct la magazinul dvs. de mobilier.

**RUS** Прямая директная служба по доставке фурнитуры  
 Если отсутствует какая-либо деталь из металла, то вы можете отправить эту информацию по электронной почте на адрес, указанный ниже. Однако, только таким образом мы можем доставить только фурнитуру. Если у вас есть другая претензия относительно предмета мебели, то просим вас обратиться по этому вопросу непосредственно в магазин, где вы приобрели мебель.

**S** Vše direktno za montažo kování  
 Odm du se vám nějaký díl chybí, můžete tuto službu využít také e-mailem přímo na níže uvedenou adresu. Tuto částku však můžeme poslat jen tímto způsobem. Pokud byste měli nějaký jiný důvod, obraťte se přímo na svého prodejce nábytku.

**ES** Nuestro servicio directo para el montaje  
 Si le falta algún accesorio, puede enviar esta tarjeta de servicio directamente a la siguiente dirección. No obstante, por este método solo podemos enviar accesorios. Si tiene alguna otra objeción sobre su mueble, consulte directamente con su mueblería.

**TR** Doğrudan hizmet için montaj malzemeleri  
 Bir demir aksesuarınız yoksa, bu servisi kartını doğrudan aşağıdaki buktan adrese doğrudan e-mail ile gönderebilirsiniz. Sadece bu şekilde demir aksesuarları doğrudan gönderebiliriz. Mobilyanızla ilgili başka bir şikayetiniz varsa lütfen doğrudan mobilya satıcınıza danışın.

# RAVENNA 51

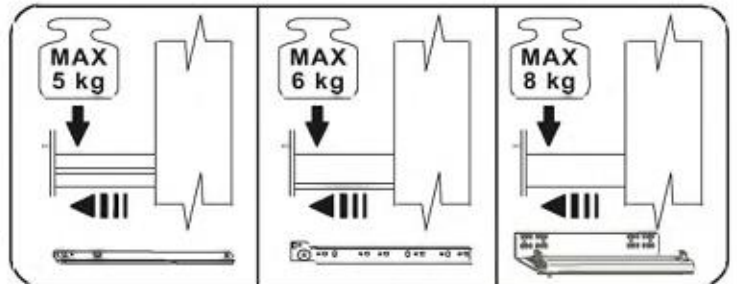
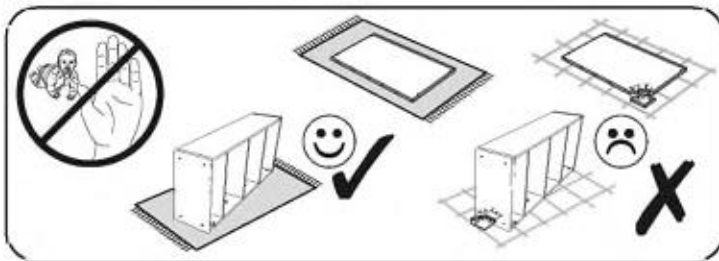
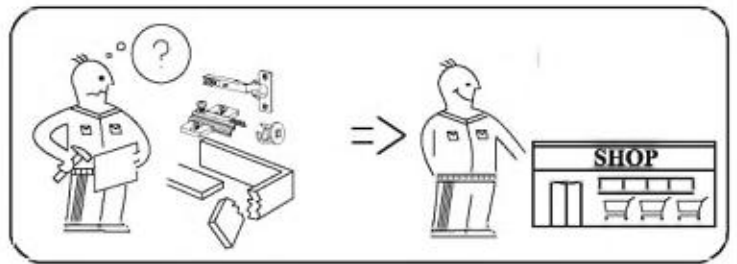
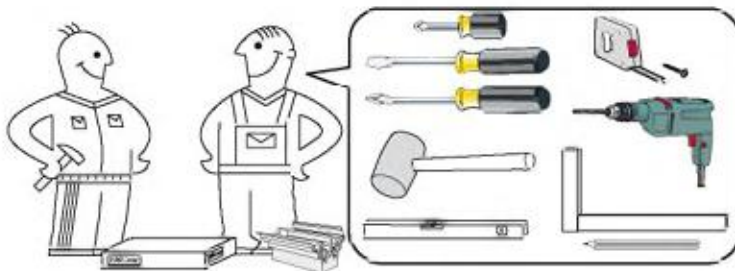
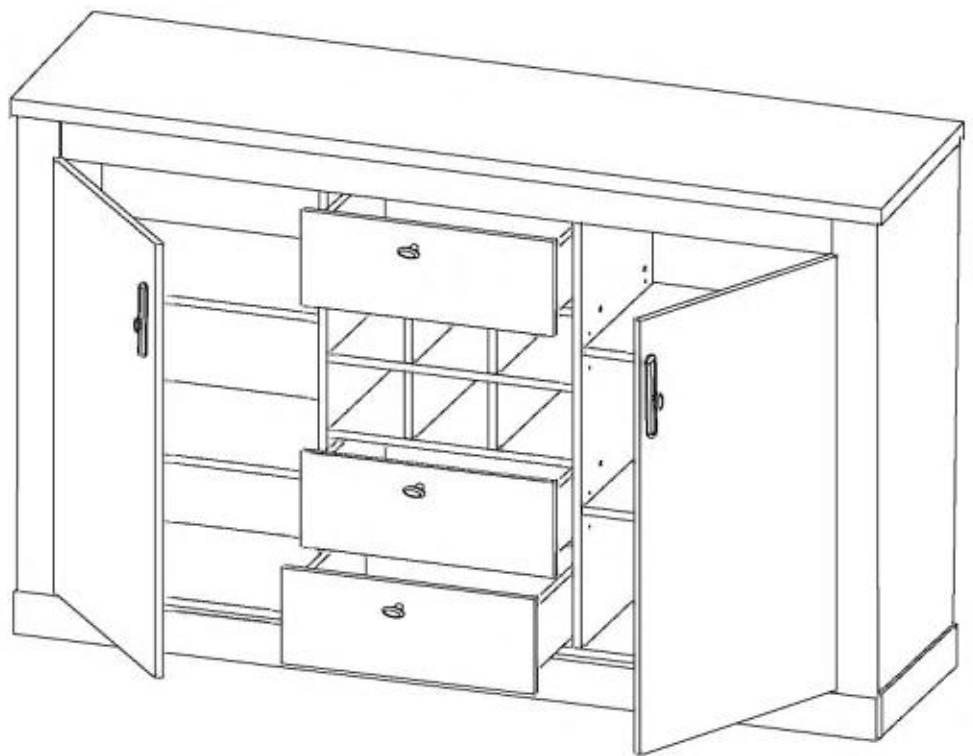
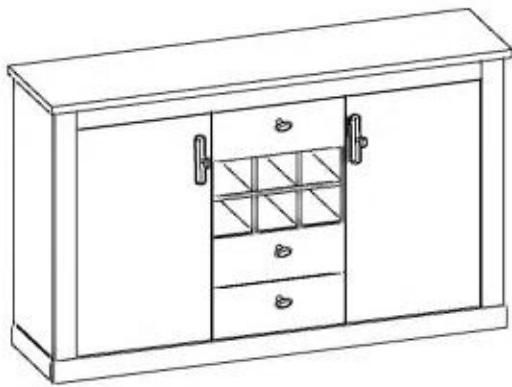

# RAVENNA 51

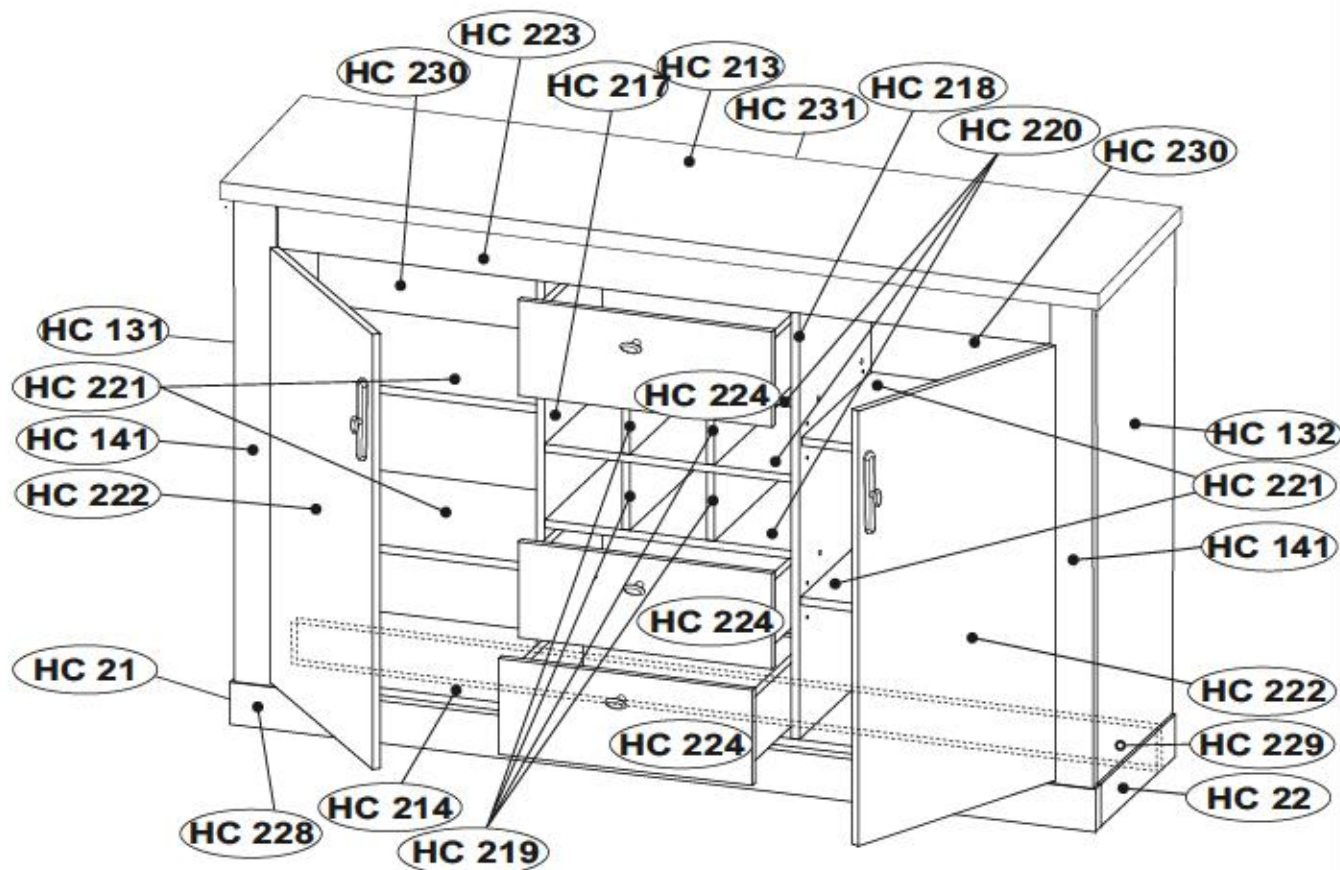

max.



max.



HC 214 HC 213

HC 220 HC 221

x3

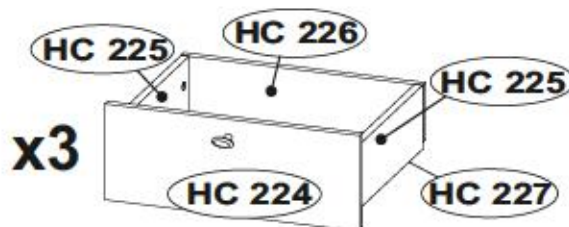

HC 21	x1	386	80	28	2/2
HC 22	x1	386	80	28	2/2
HC 131	x1	894	389	15	1/2
HC 132	x1	894	389	15	1/2
HC 141	x2	894	80	22	1/2
HC 213	x1	1655	431	28	2/2
HC 214	x1	1583	369	15	2/2
HC 217	x1	879	368	15	1/2
HC 218	x1	879	368	15	1/2
HC 219	x4	126	366	15	1/2
HC 220	x3	464	367	15	2/2

HC 221	x4	543	360	15	1/2
HC 222	x2	814	484	15	1/2
HC 223	x1	1455	74	18	2/2
HC 224	x3	477	180	15	2/2
HC 225	x6	313	125	15	2/2
HC 226	x3	454	111	15	2/2
HC 227	x3	435	334	2.5	2/2
HC 228	x1	1628	80	28	2/2
HC 229	x1	1570	80	28	2/2
HC 230	x2	899	558	2.5	1/2
HC 231	x1	899	478	2.5	1/2



# RAVENNA 51

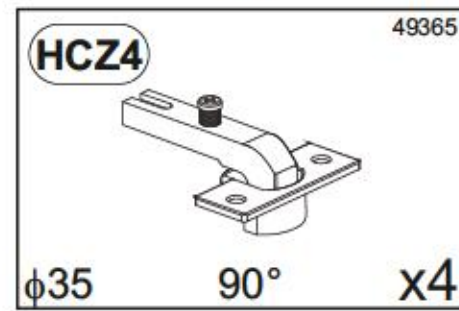
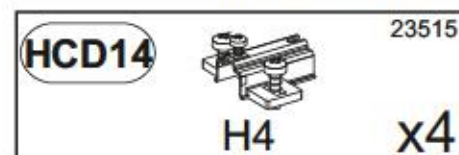
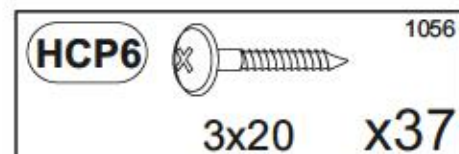
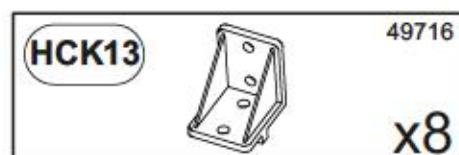
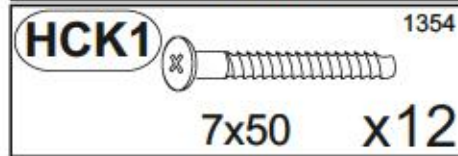
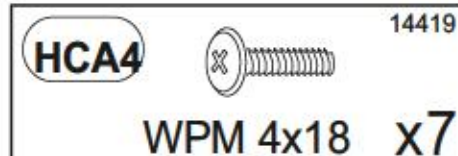
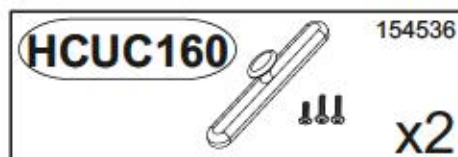
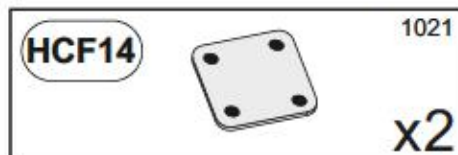
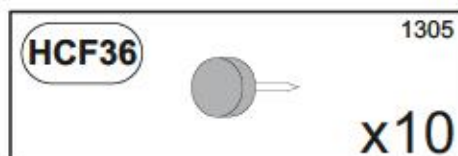
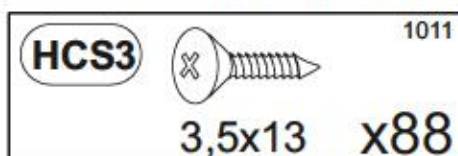
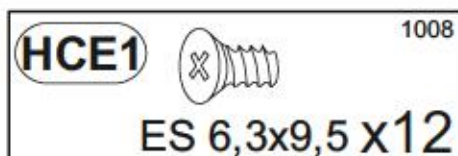
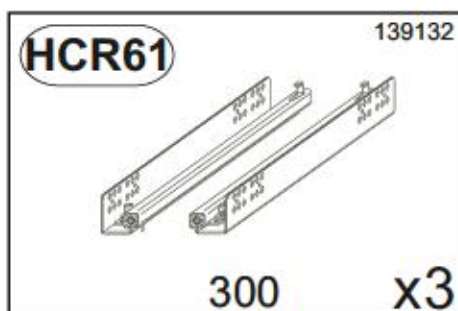
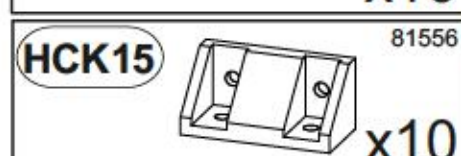
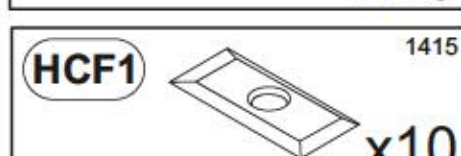
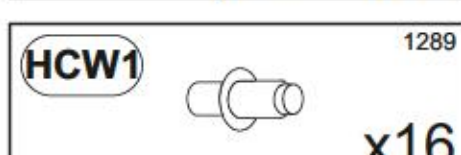
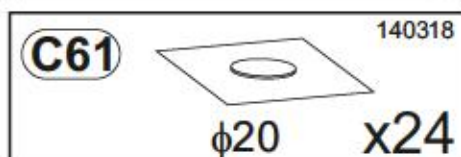
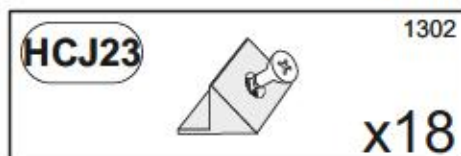
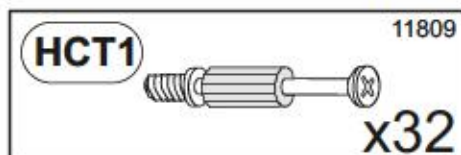
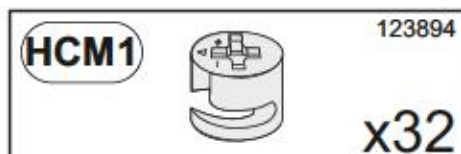
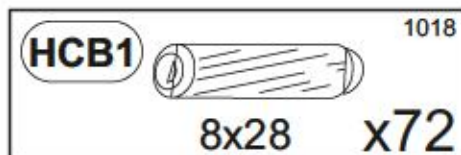

1

HCT1		13909
		x12
HCB1		1018
	8x28	x24
HCM1		123904
		x12

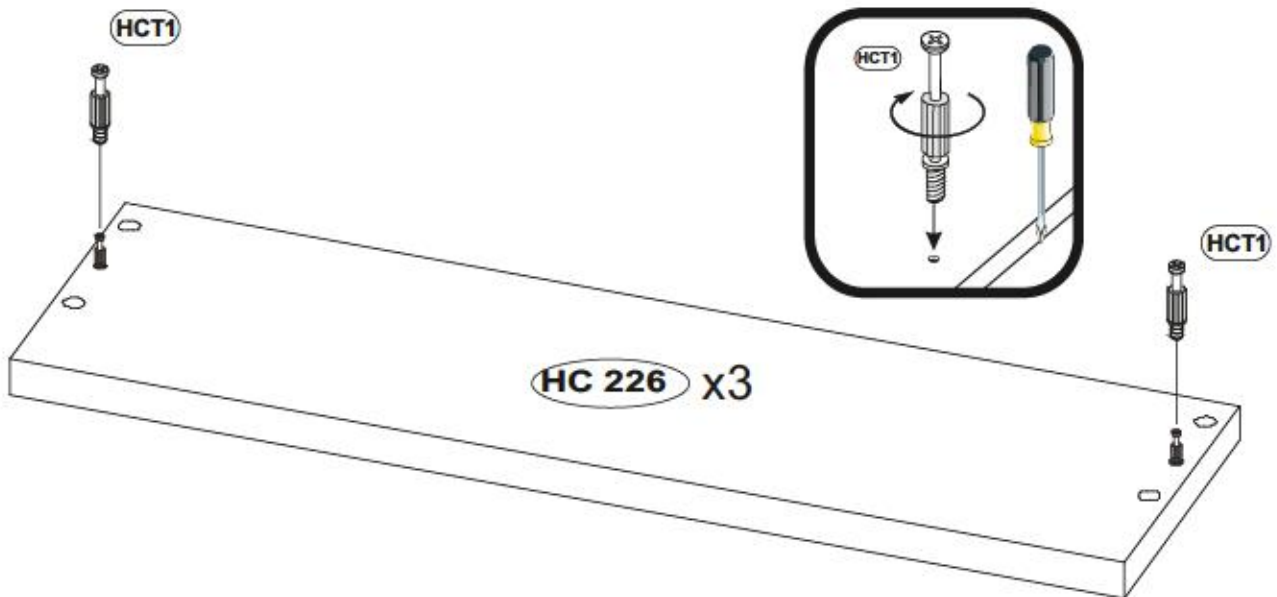
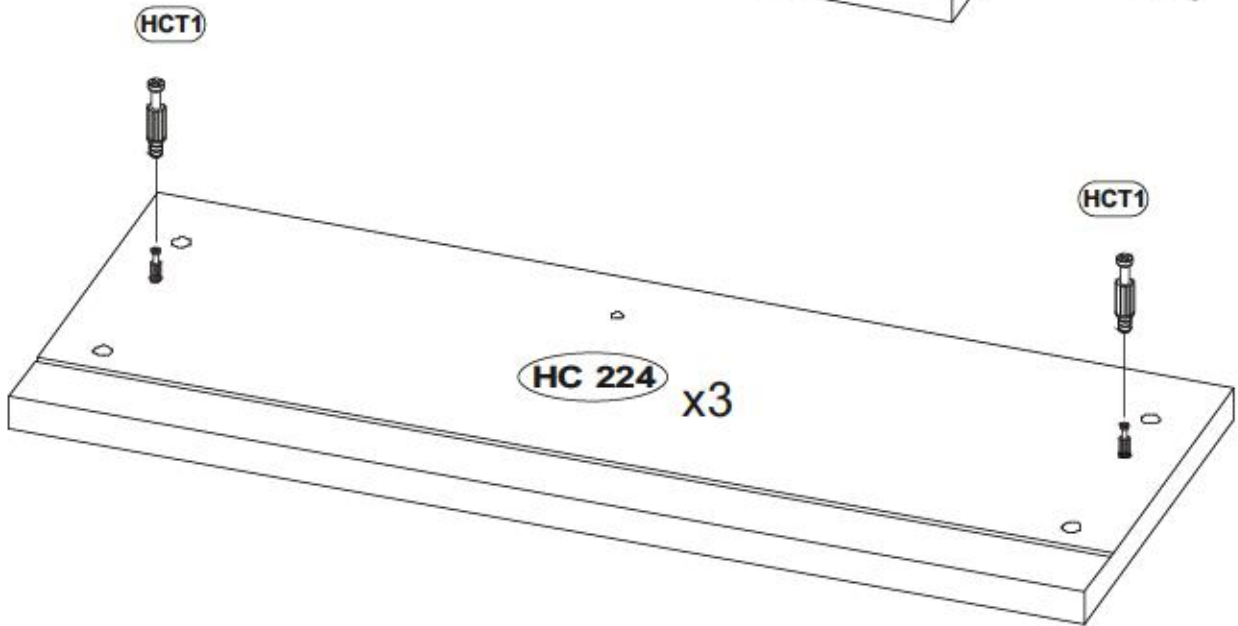
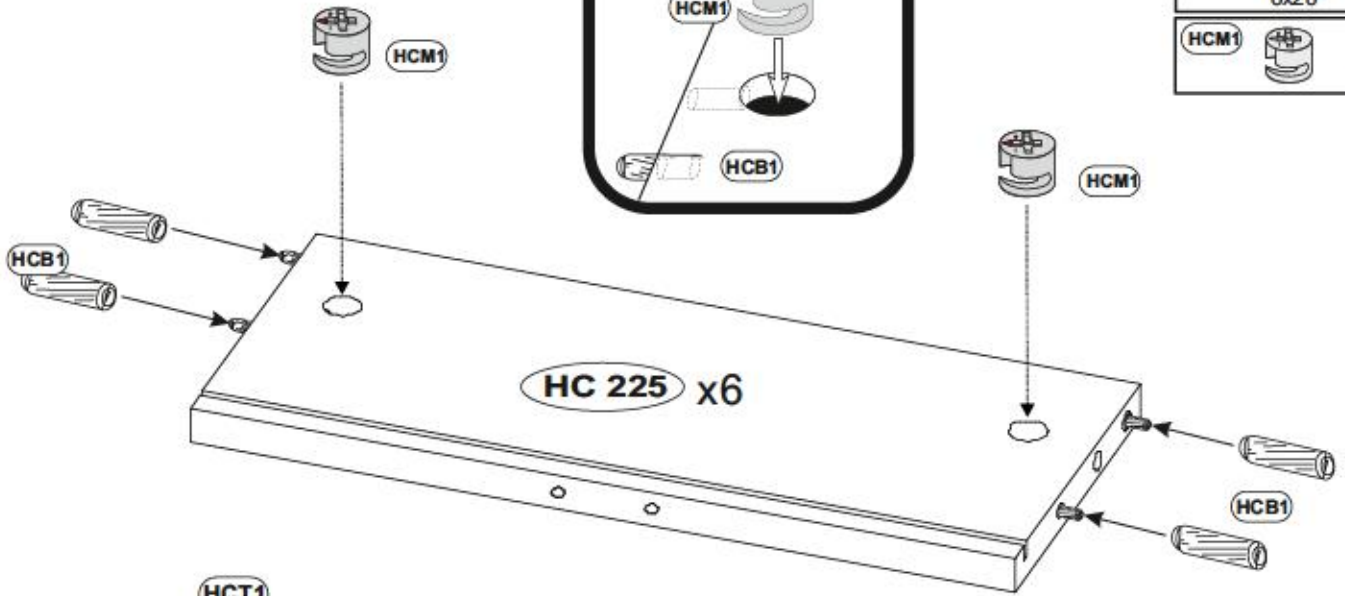
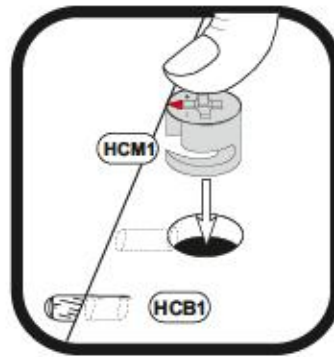



2

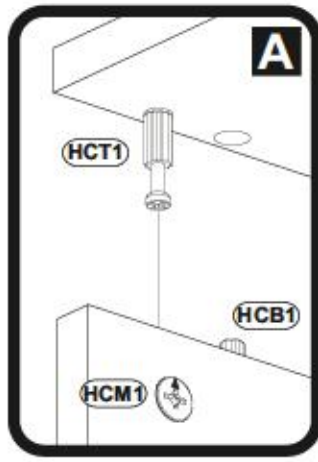
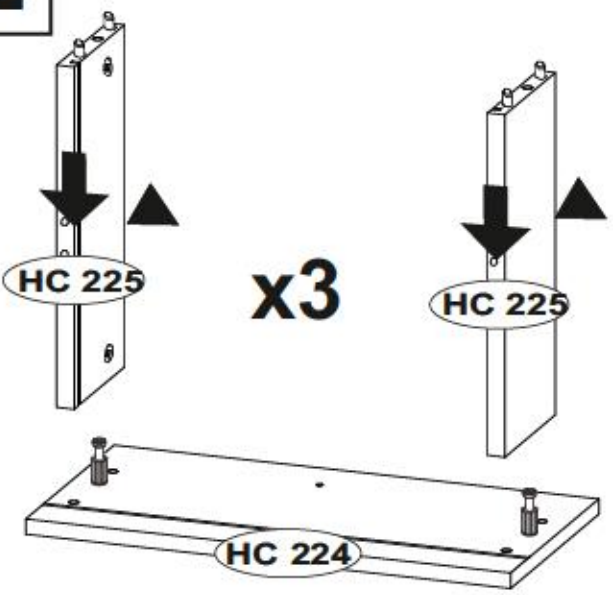

HCJ23		13/02
		x6
HCP6		10/98
		3x20 x12

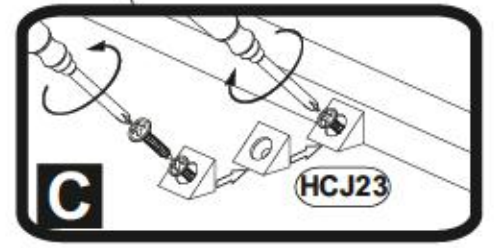
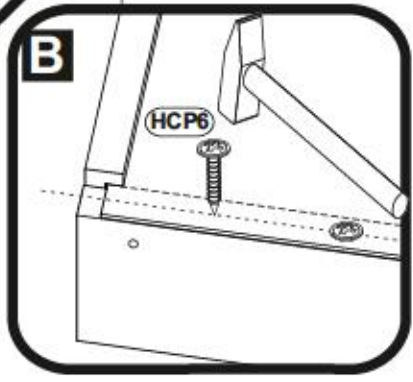
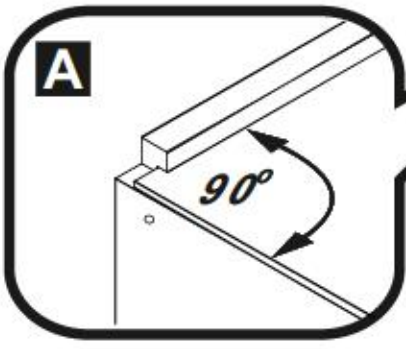
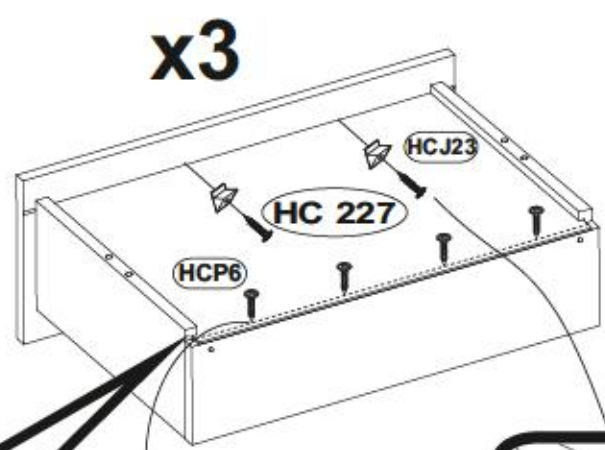
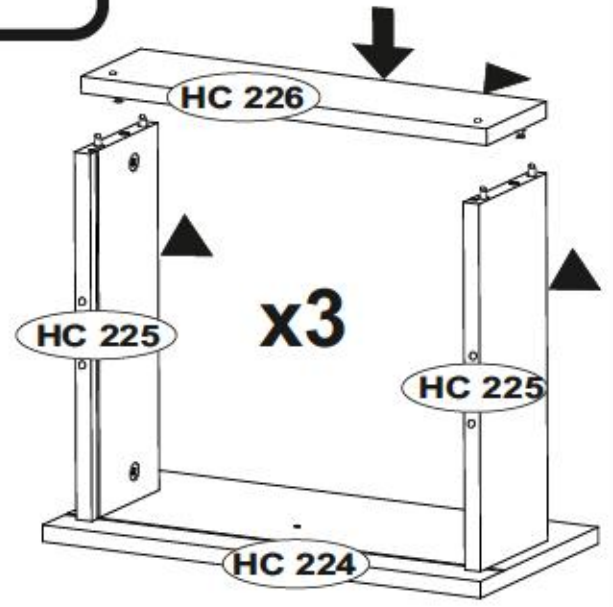
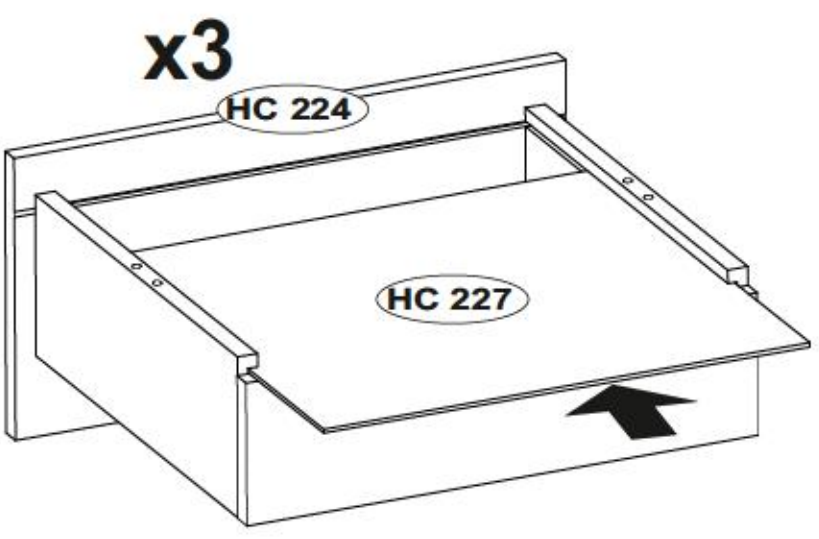

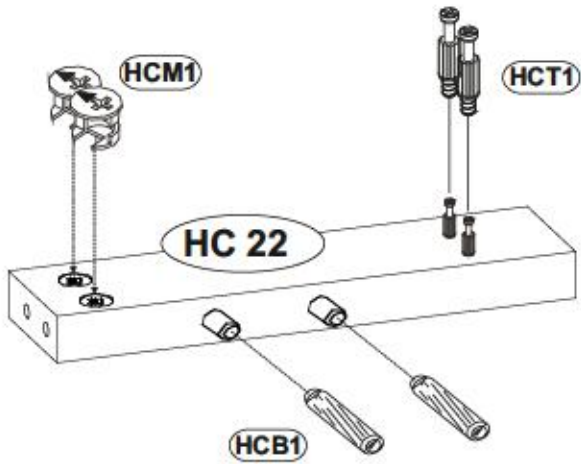

3

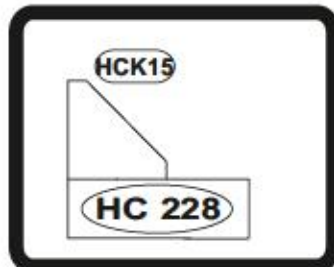
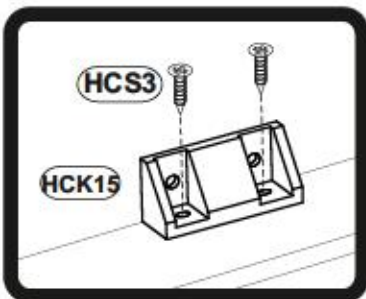
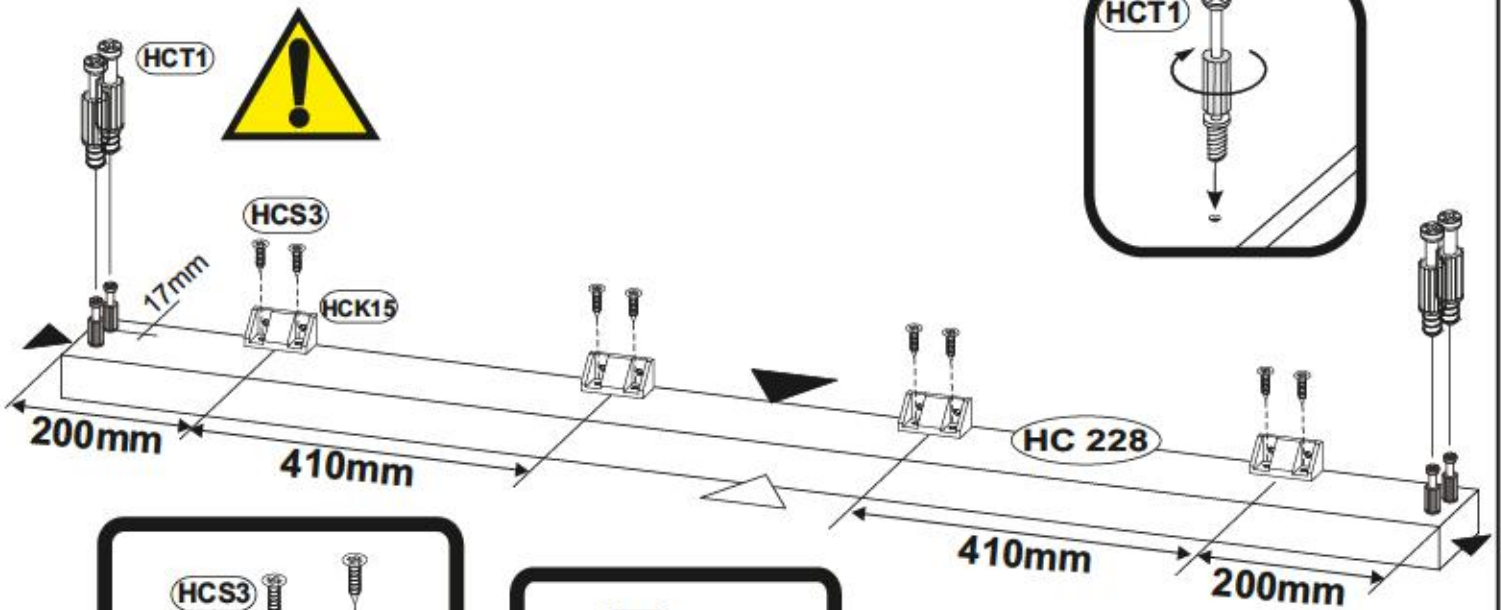
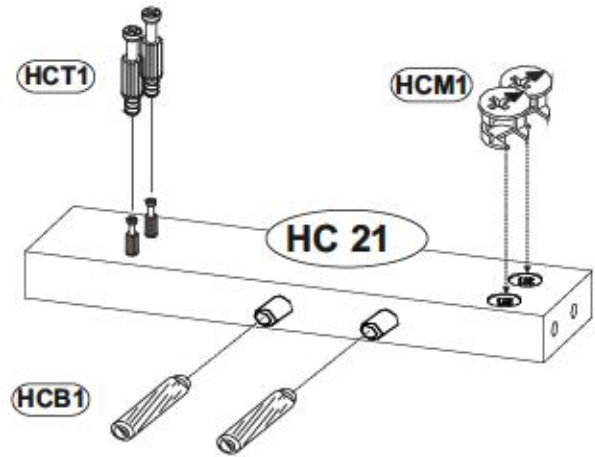
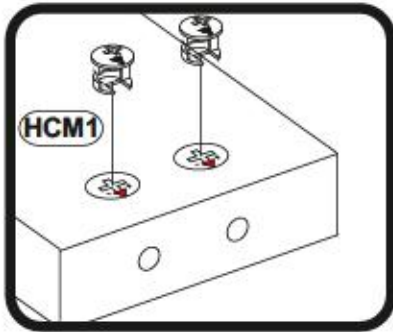

HCM1		129894	x4
HCT1		11809	x8
HCS3		1011	x8
HCK15		81599	x4
HCB1		1018	x4



4

HCM1		129804
		x4
HCS3		1011
	3,5x13	x8
HCK15		010000
		x4

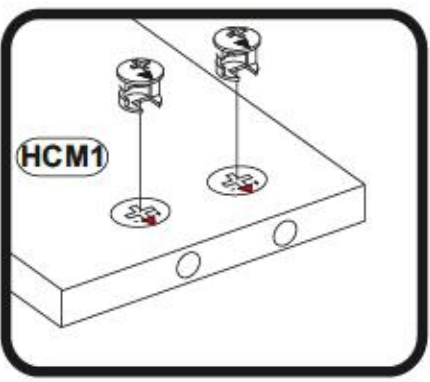
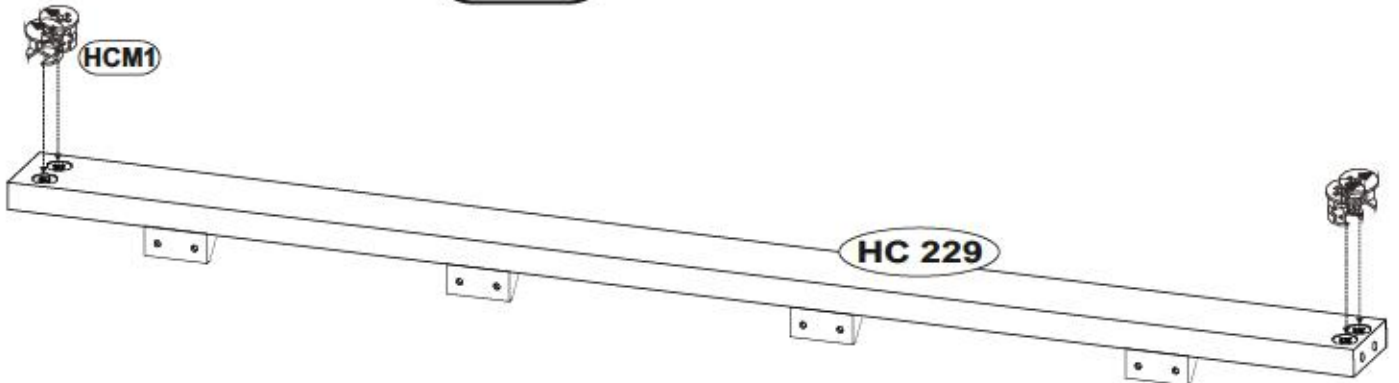
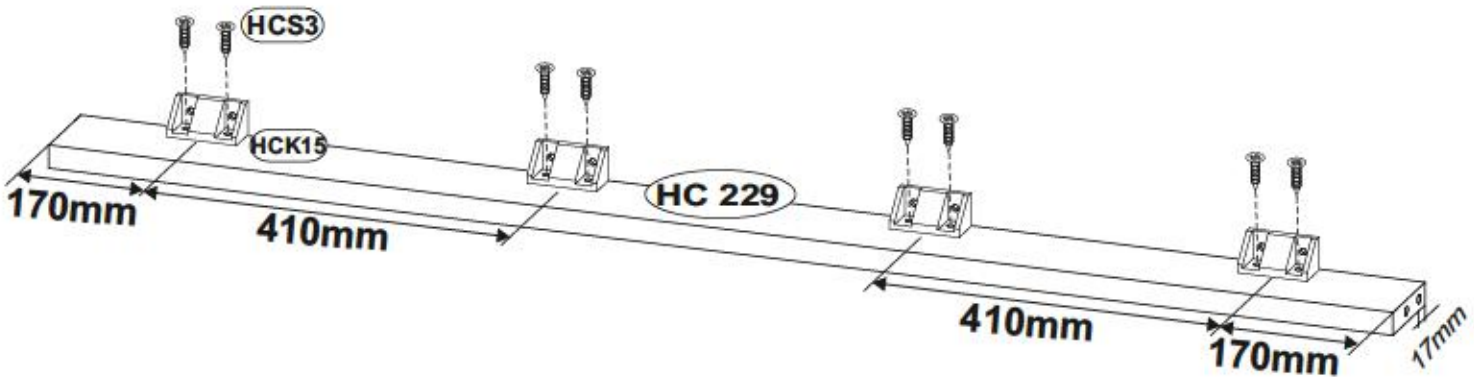
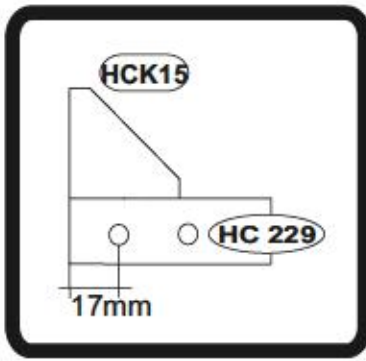
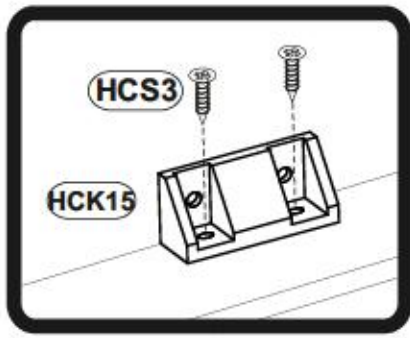

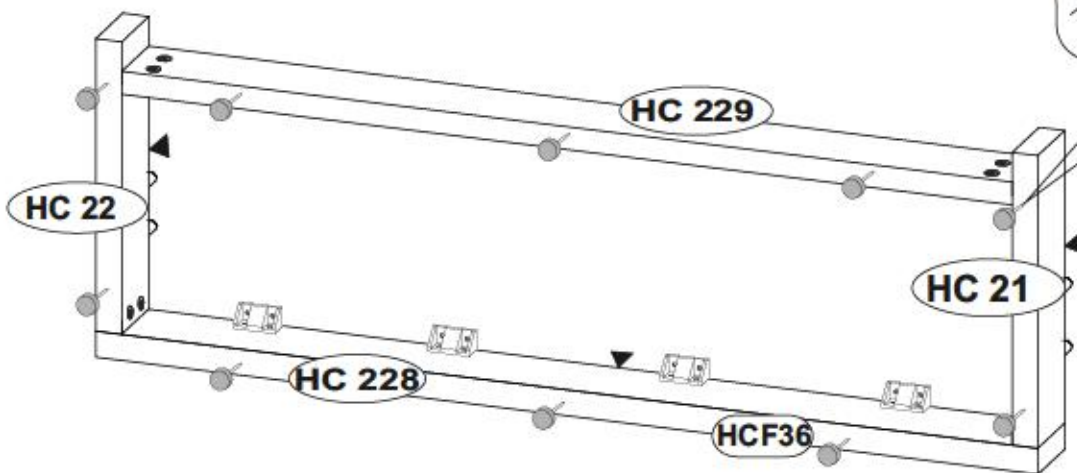
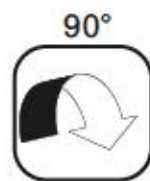
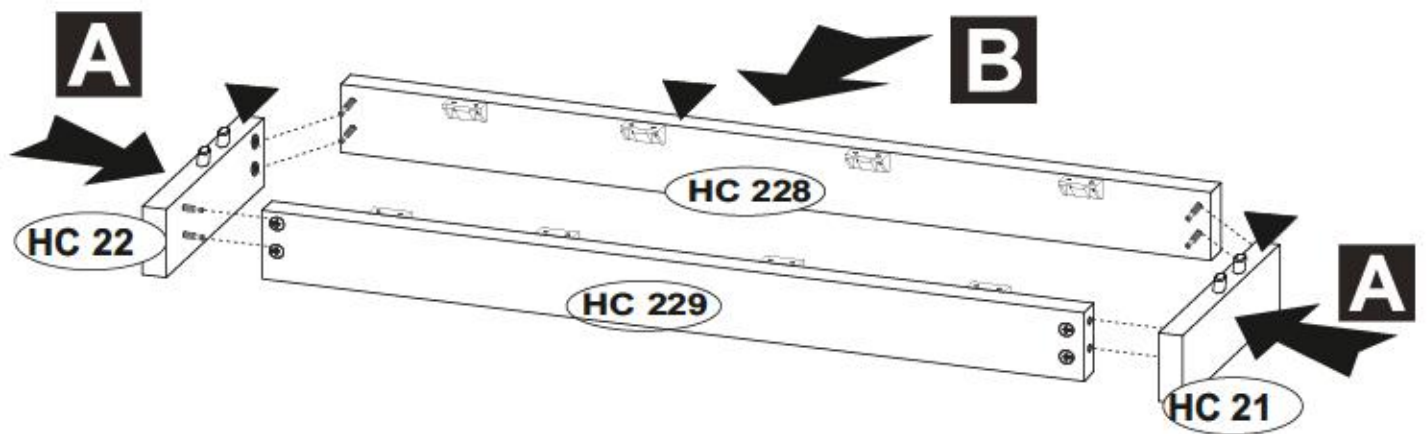
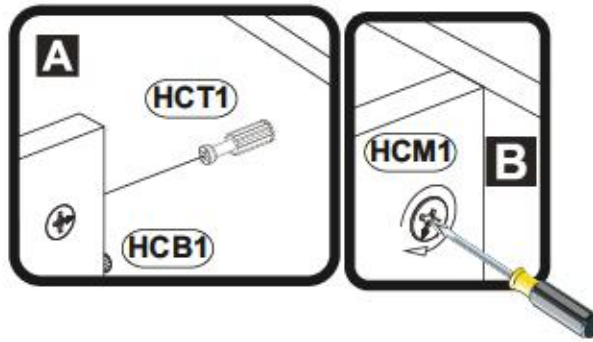



6

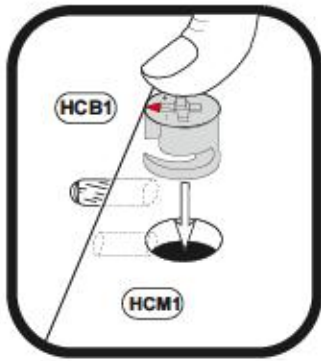

HCB1		1018
	8x28	x4
HCM1		1238/4
		x4
HCT1		1180/9
		x4

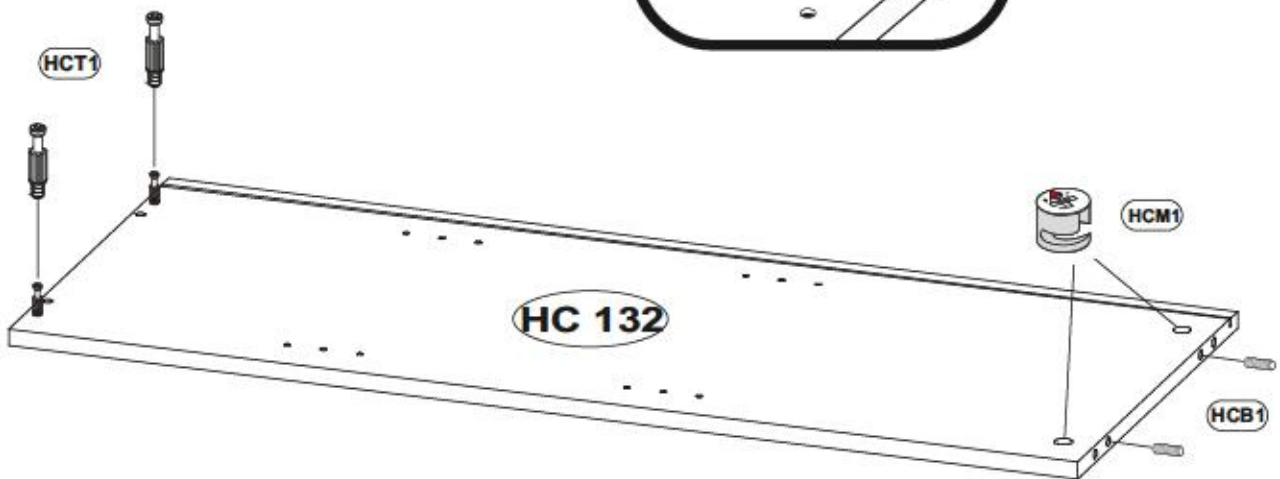
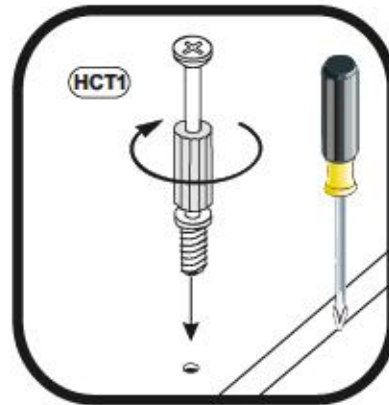
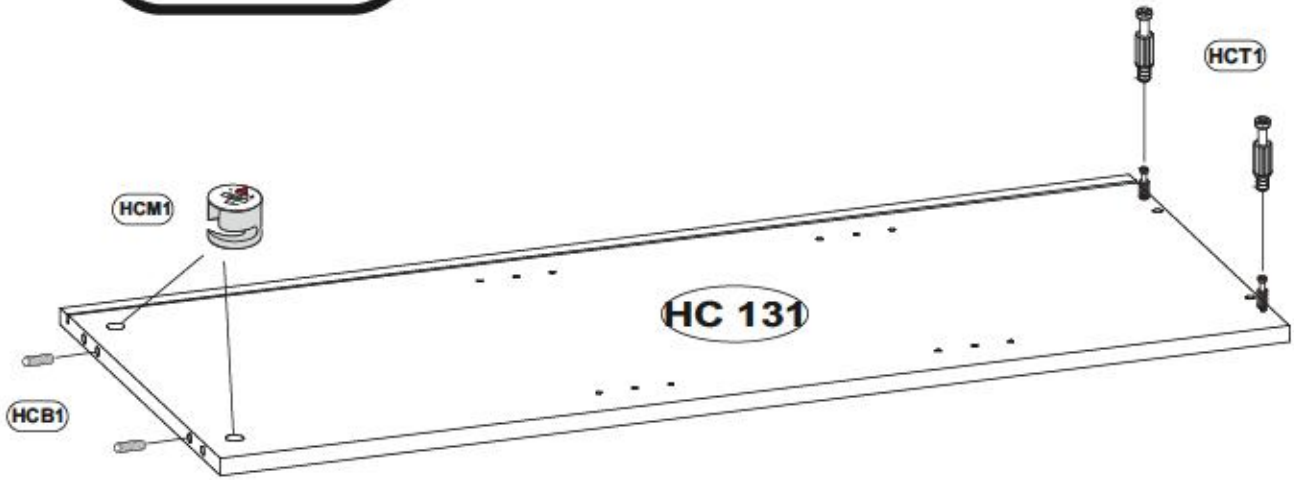



<b>HCR61</b> 139132 300 x3	<b>HCM1</b> 123894 x4
<b>HCE1</b> 1018 8x28 x8	<b>HCB1</b> 1008 ES 6,3x9,5 X12

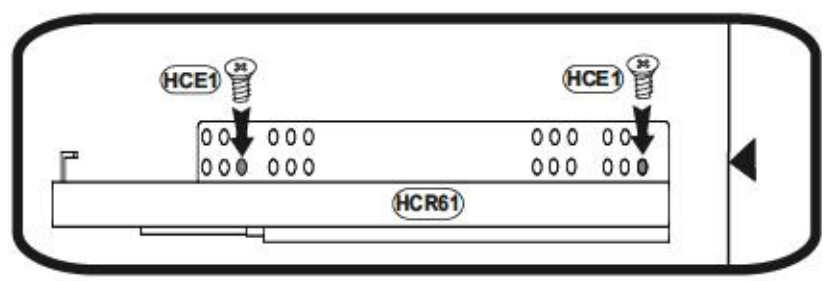
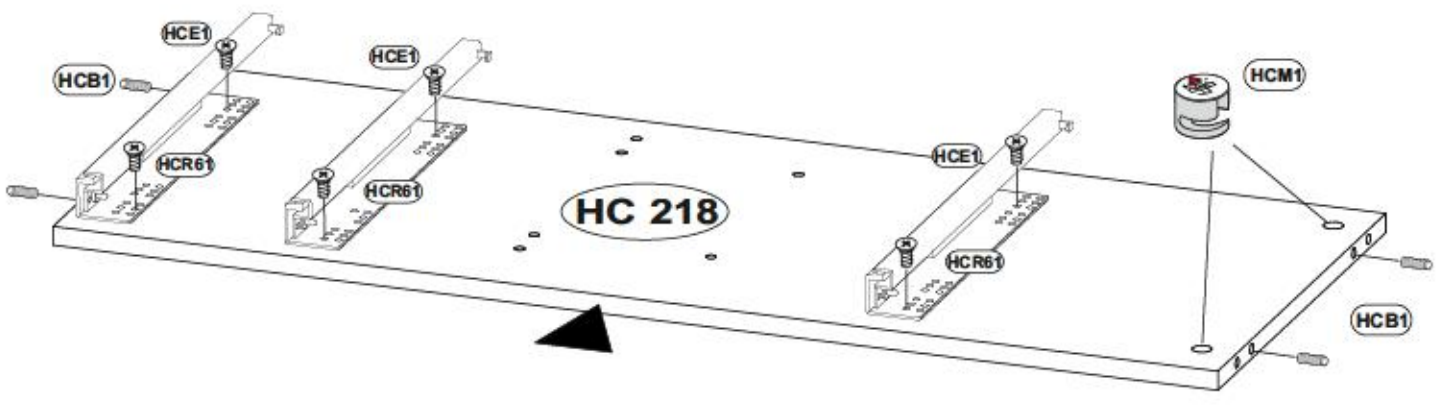
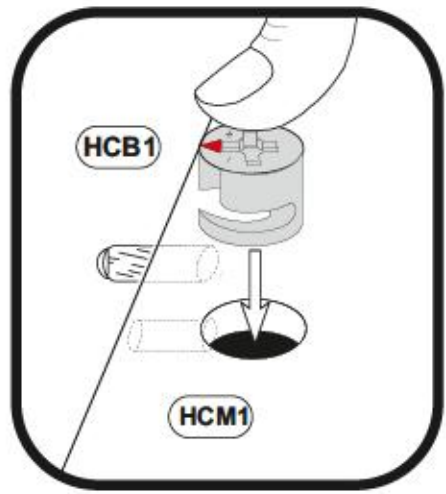
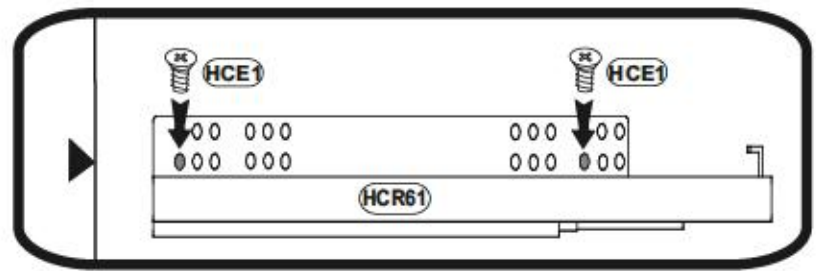
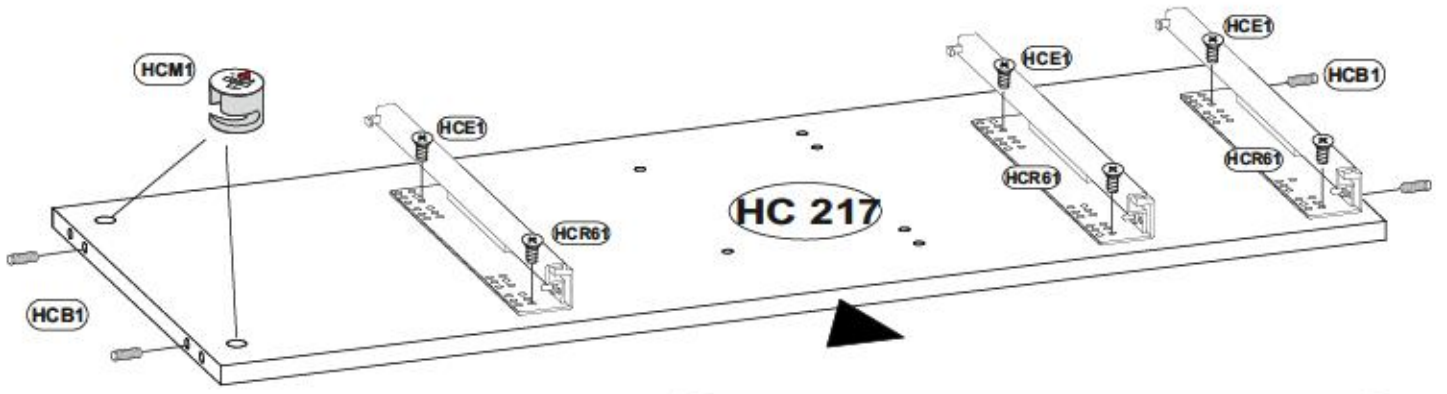

8

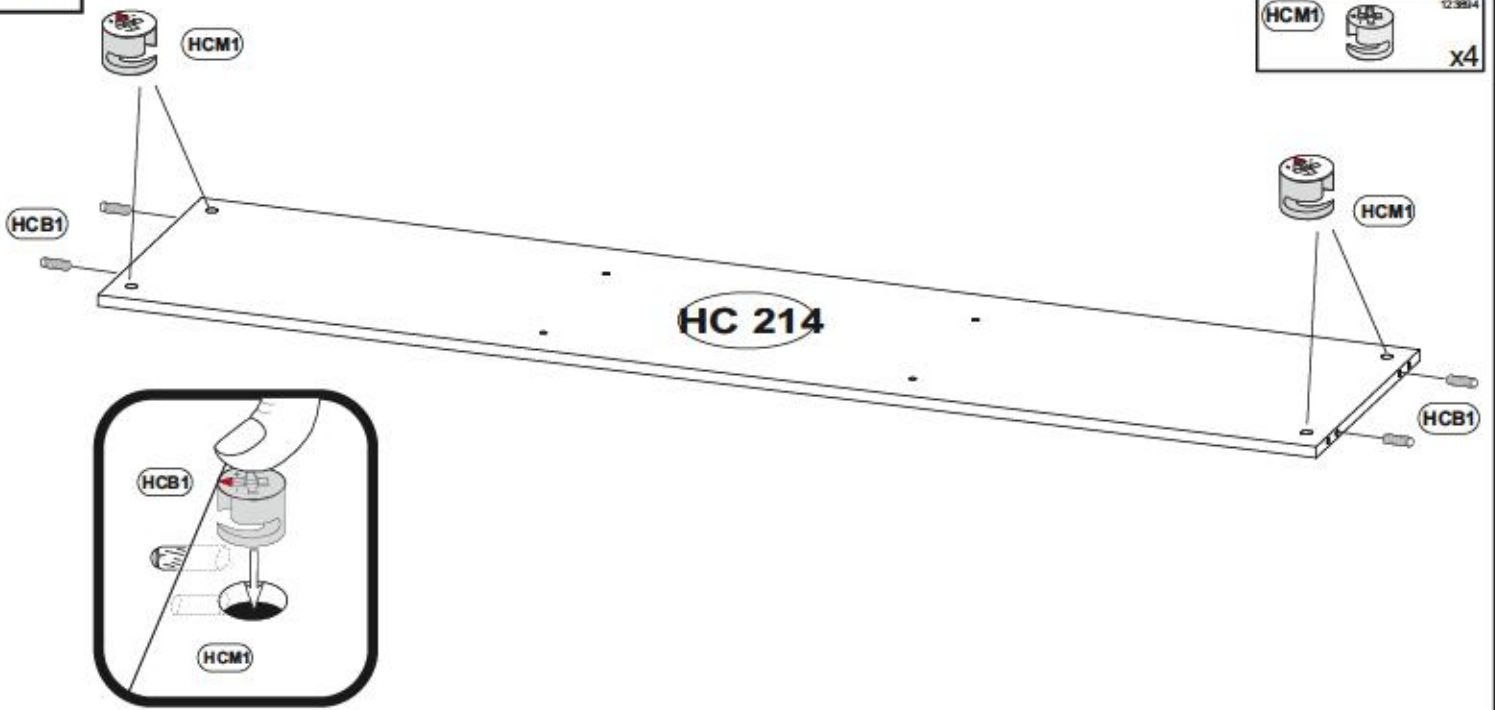



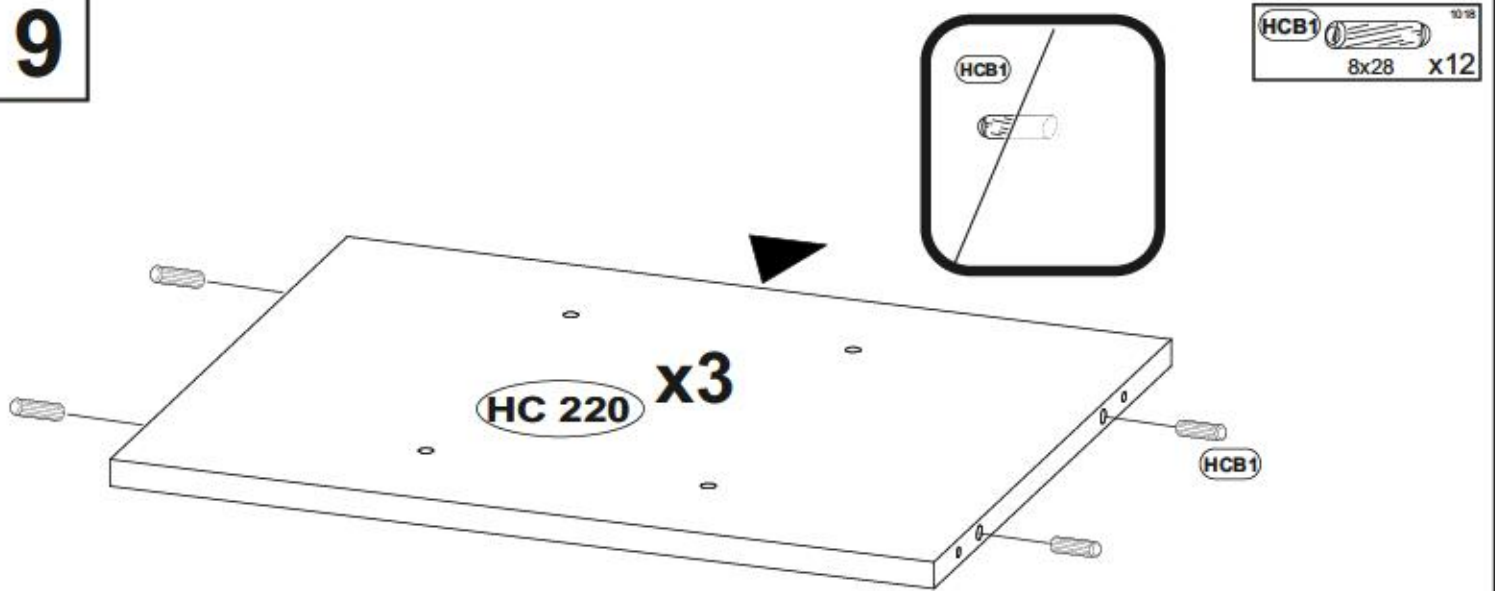

9

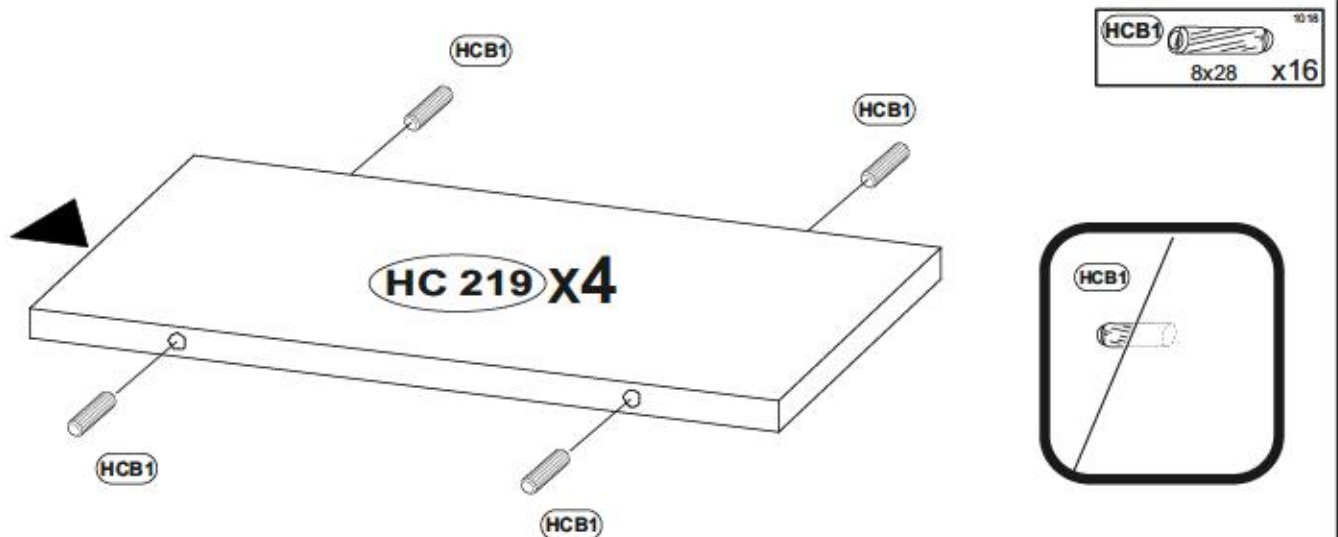

10



HCF14		1021	x2
HCK13		23482	x8
HCK15		81958	x2
HCS3		1011	x24
		3,5x13	
HCD14		29515	x4
		H4	

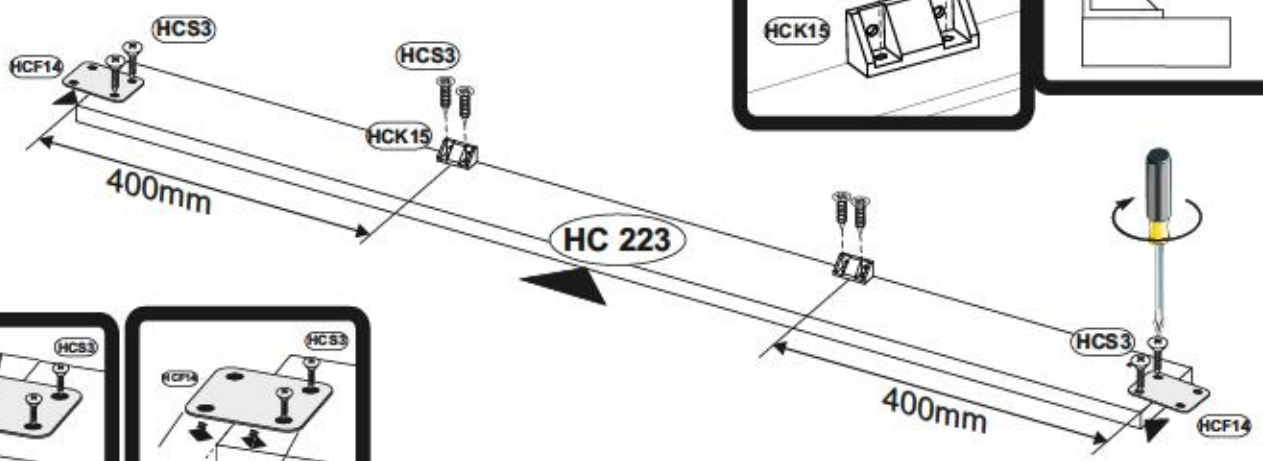
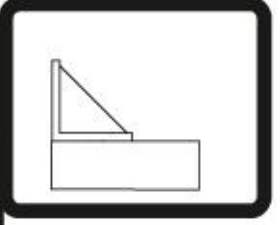
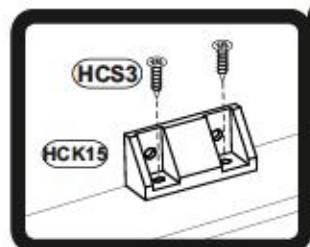
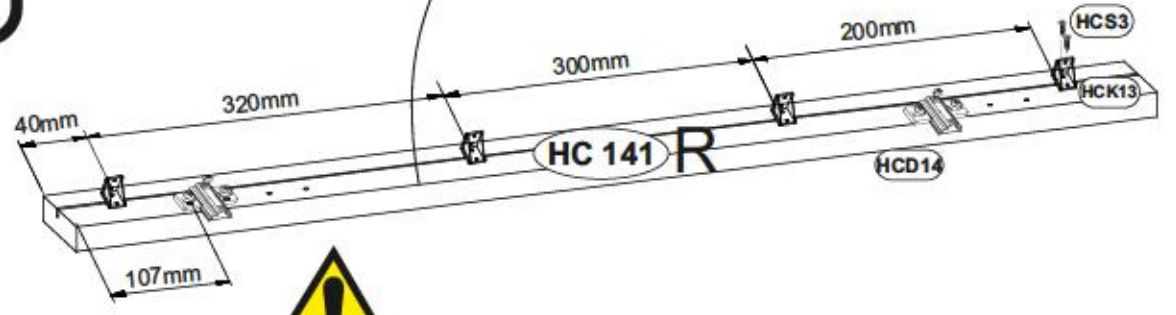
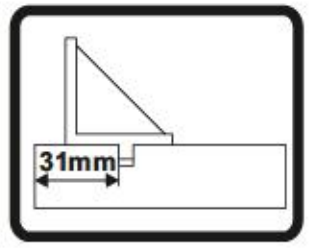
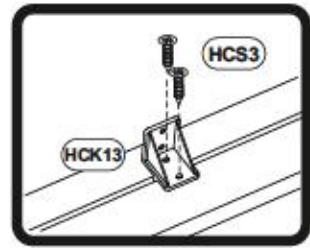
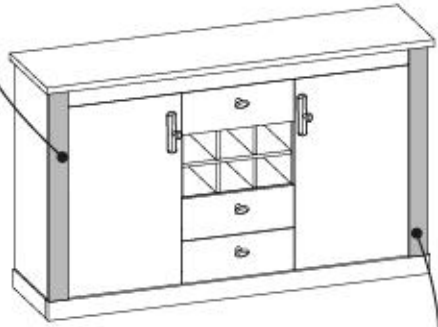
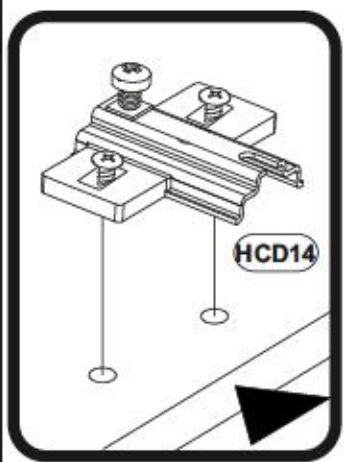
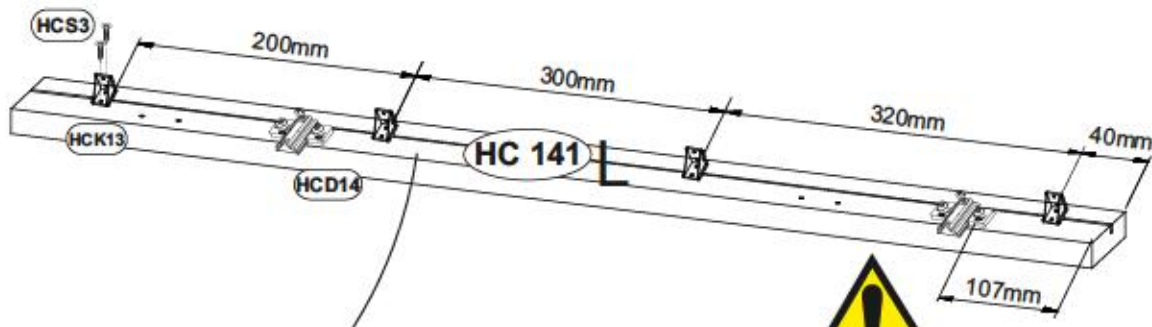

12

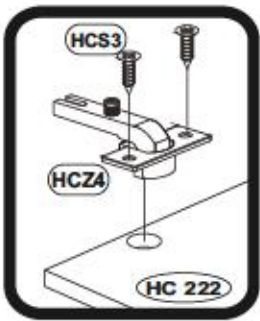
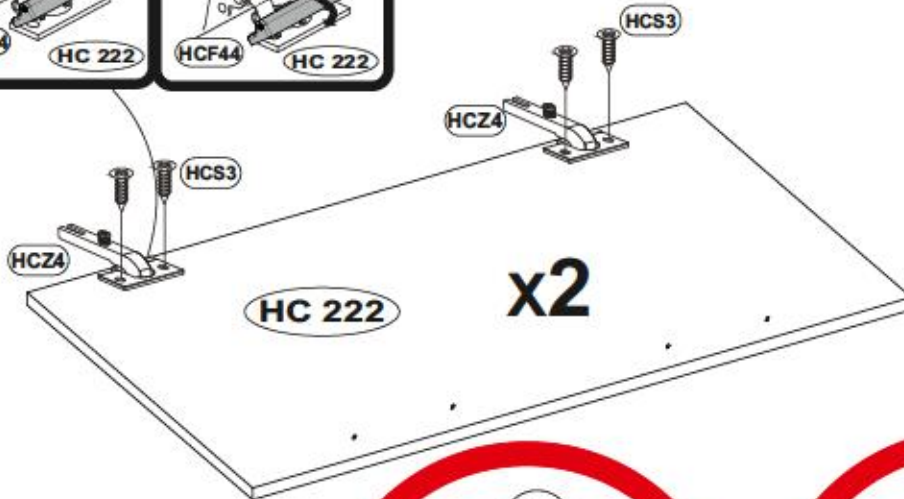
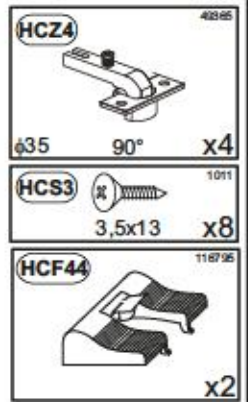
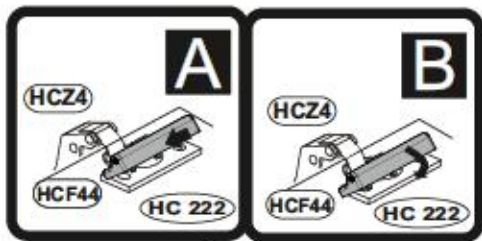

13

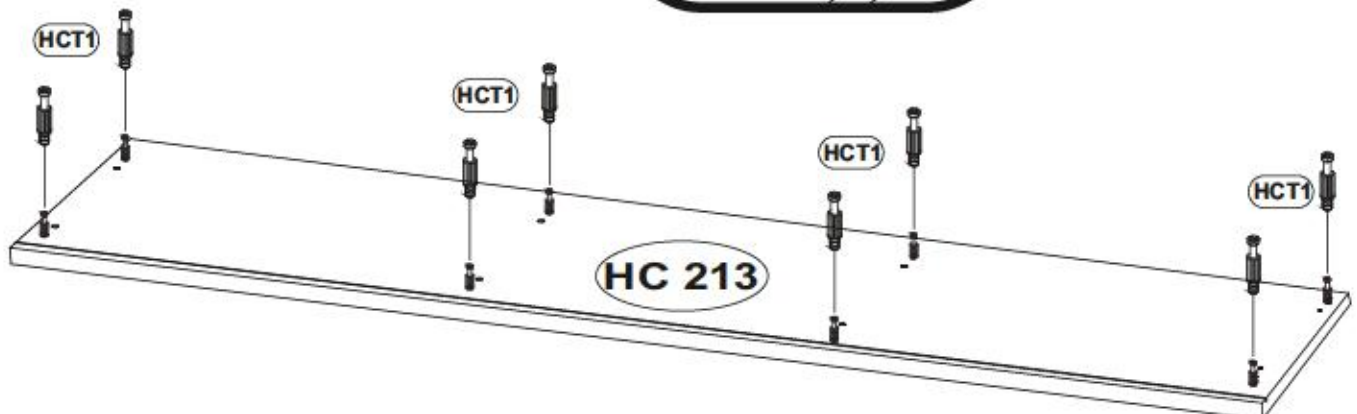
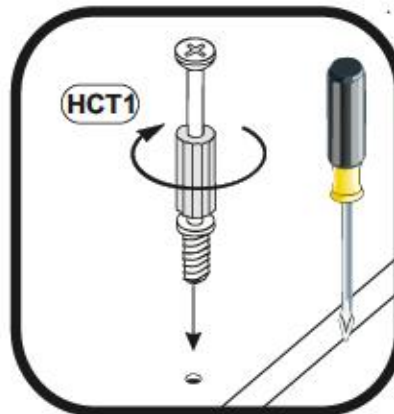
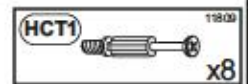



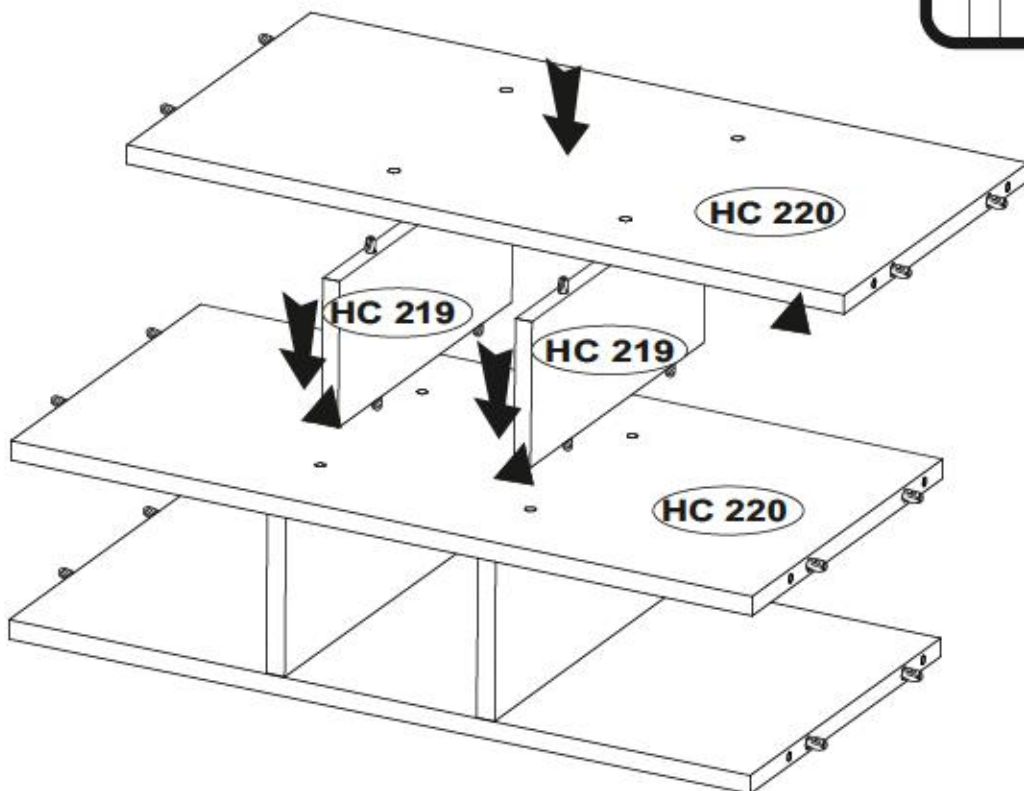
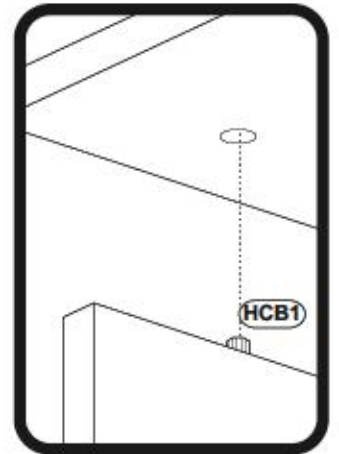
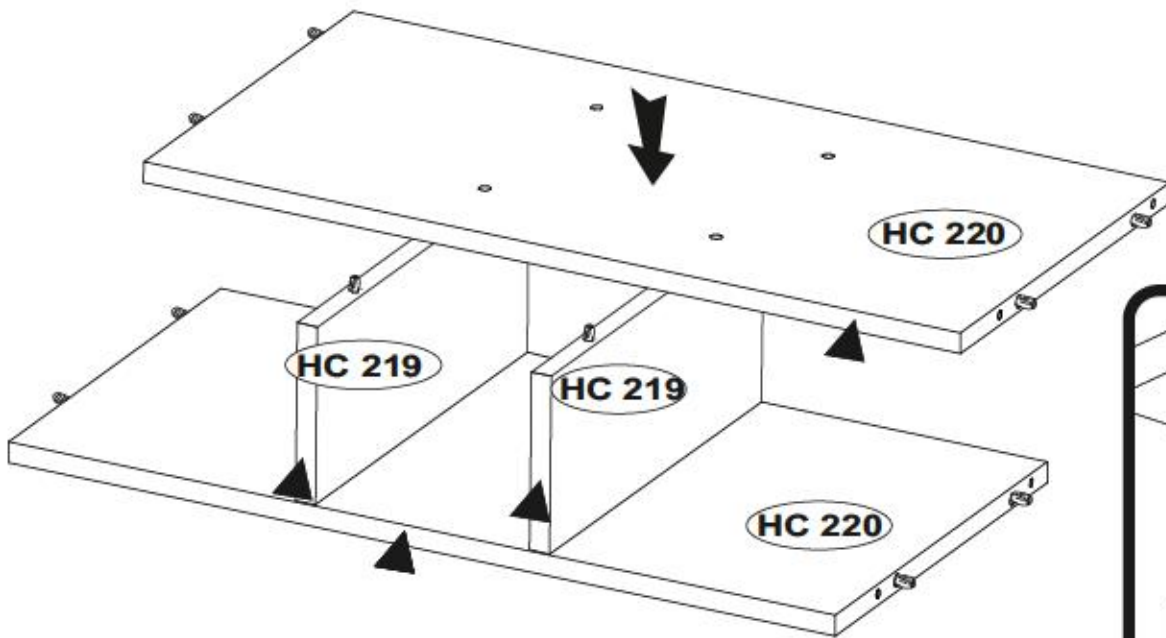
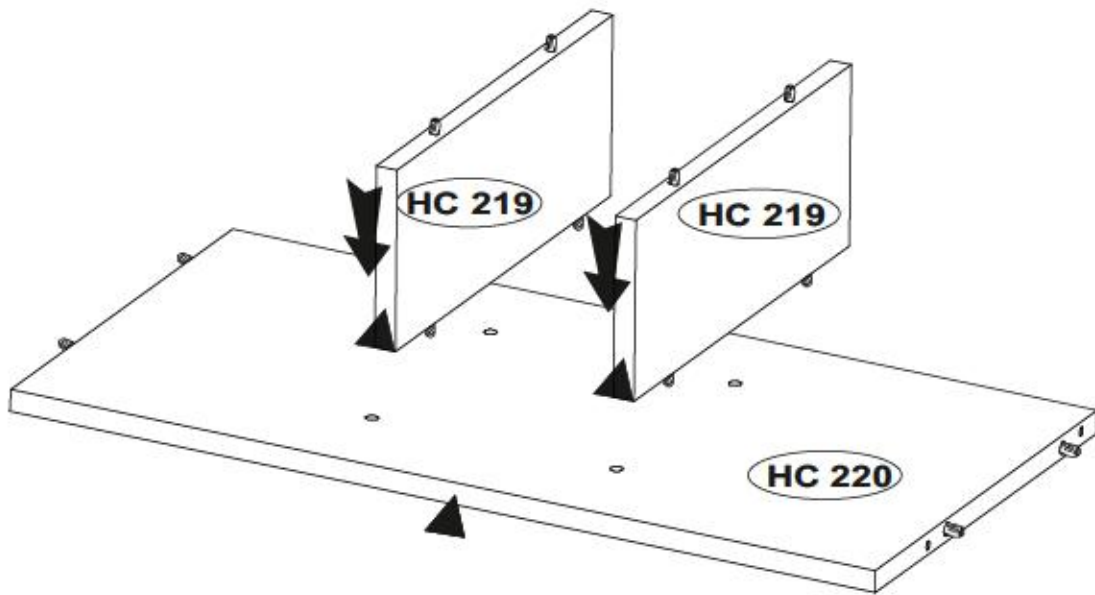



15

HCK1 1354  
7x50 x8

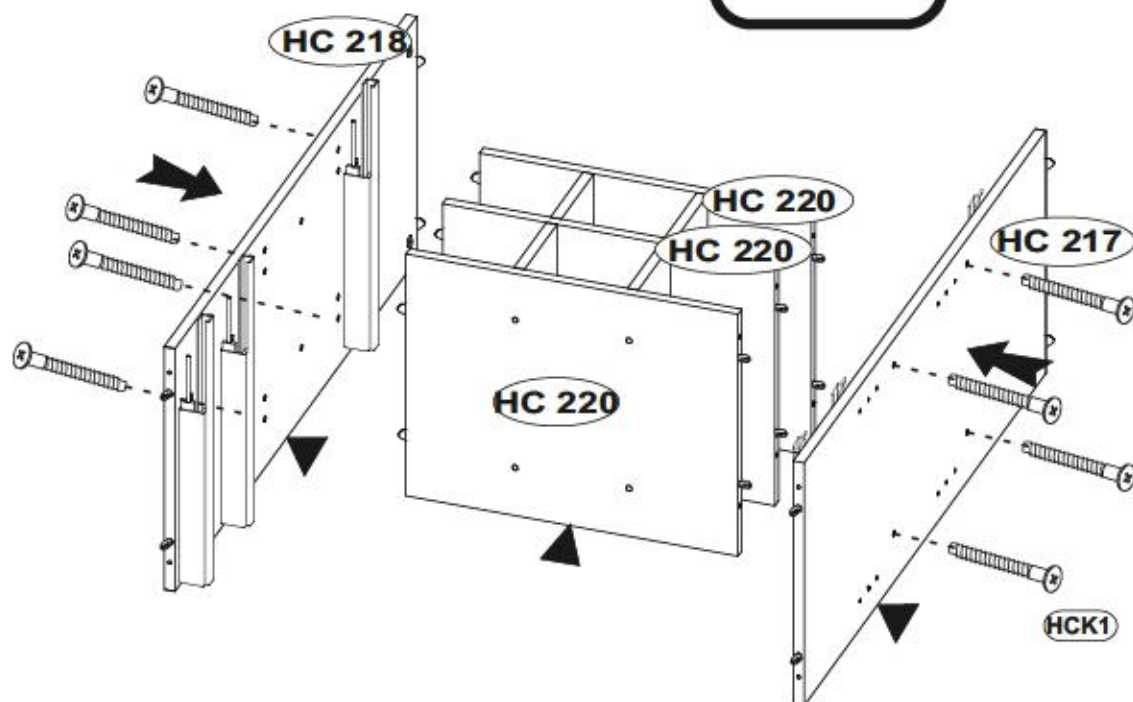

16

HCK1 1354  
7x50 x4

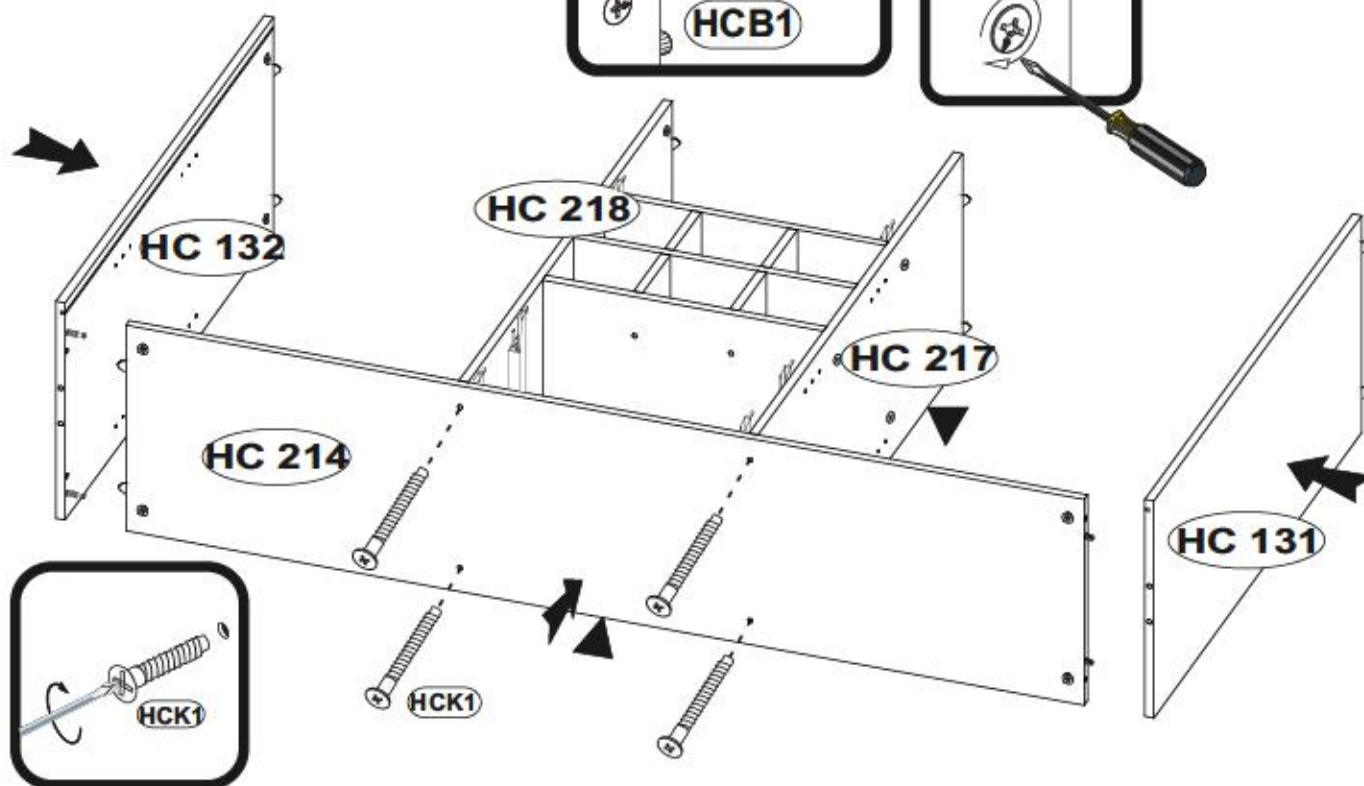
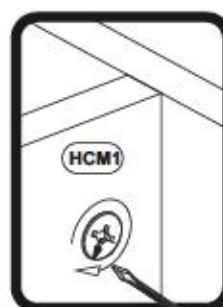
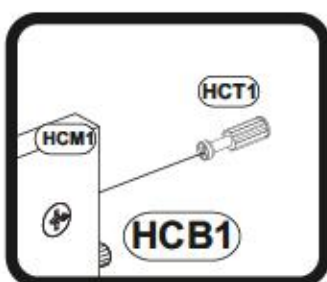

17

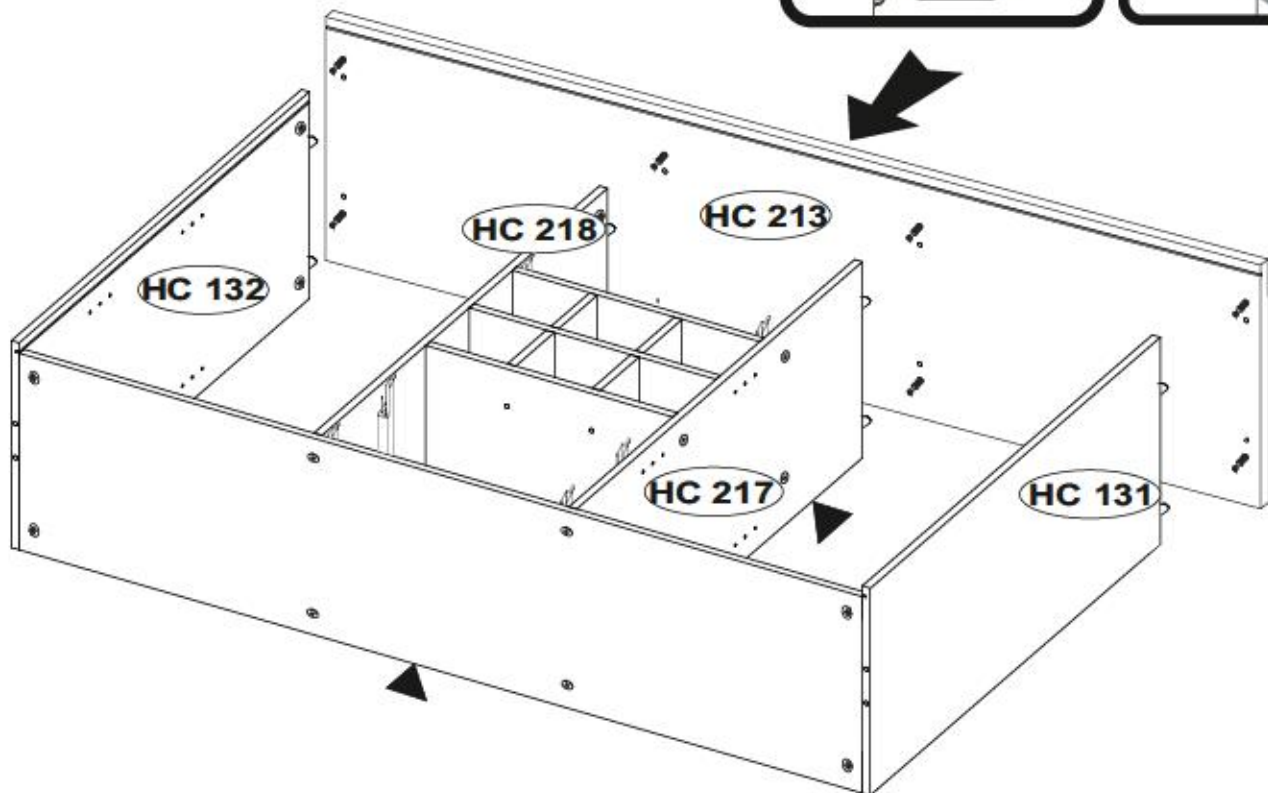
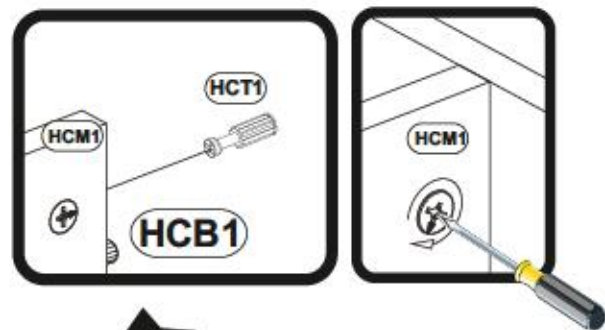

18

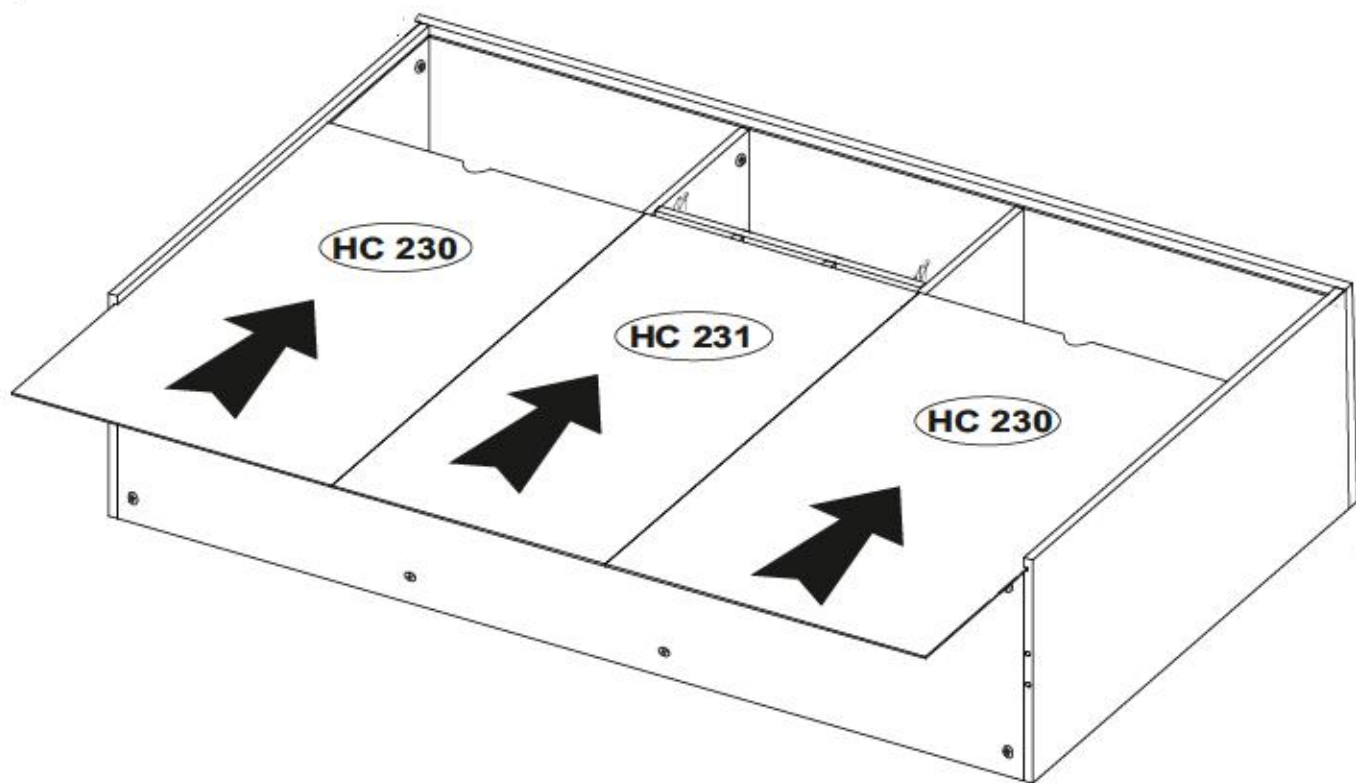

HCJ23		1302
		x12
HCP6		1096
	3x20	x25
HCF1		1485
		x10
HCS3		1011
	3,5x13	x16

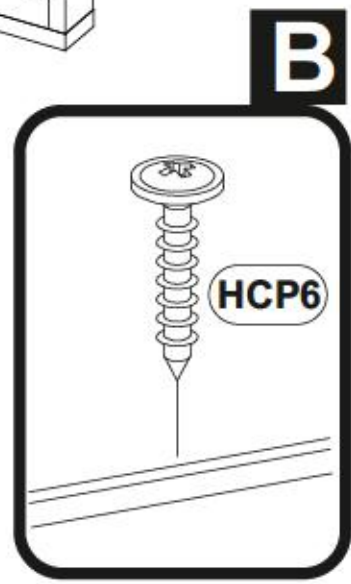
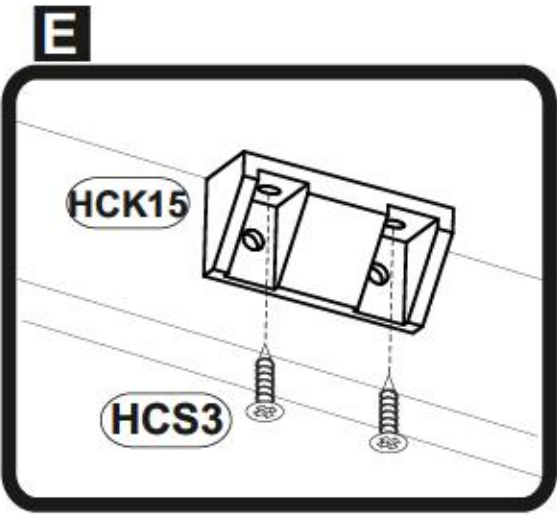
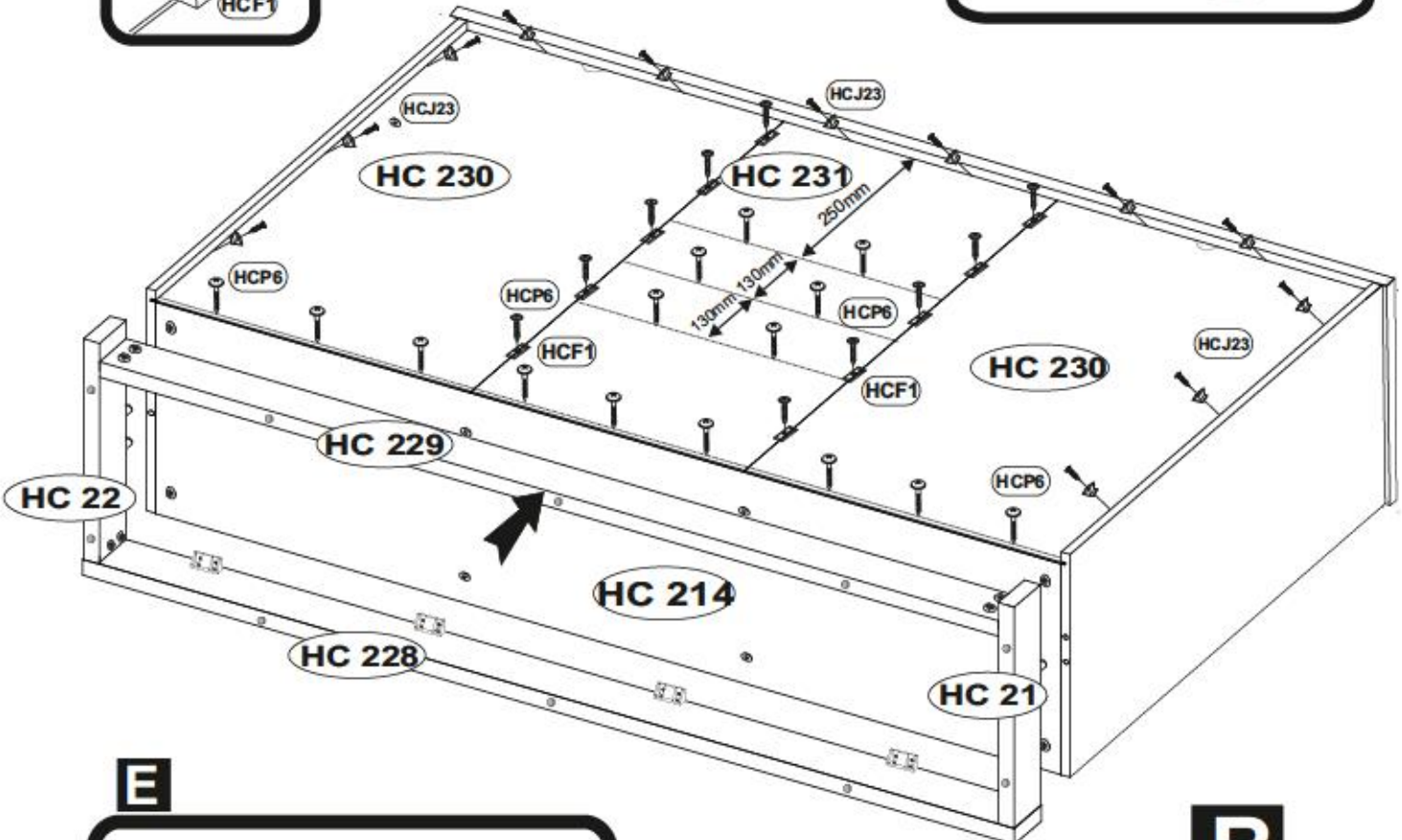
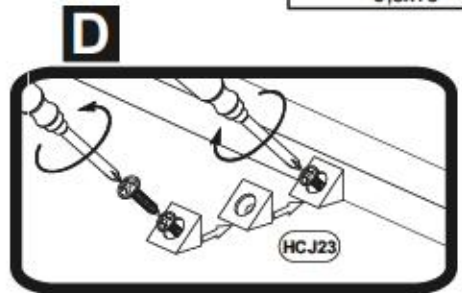
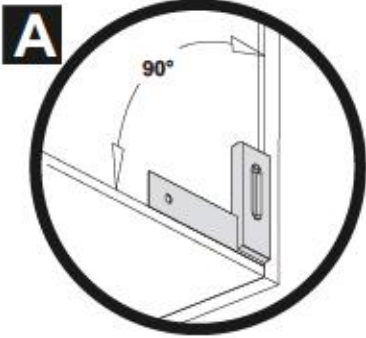



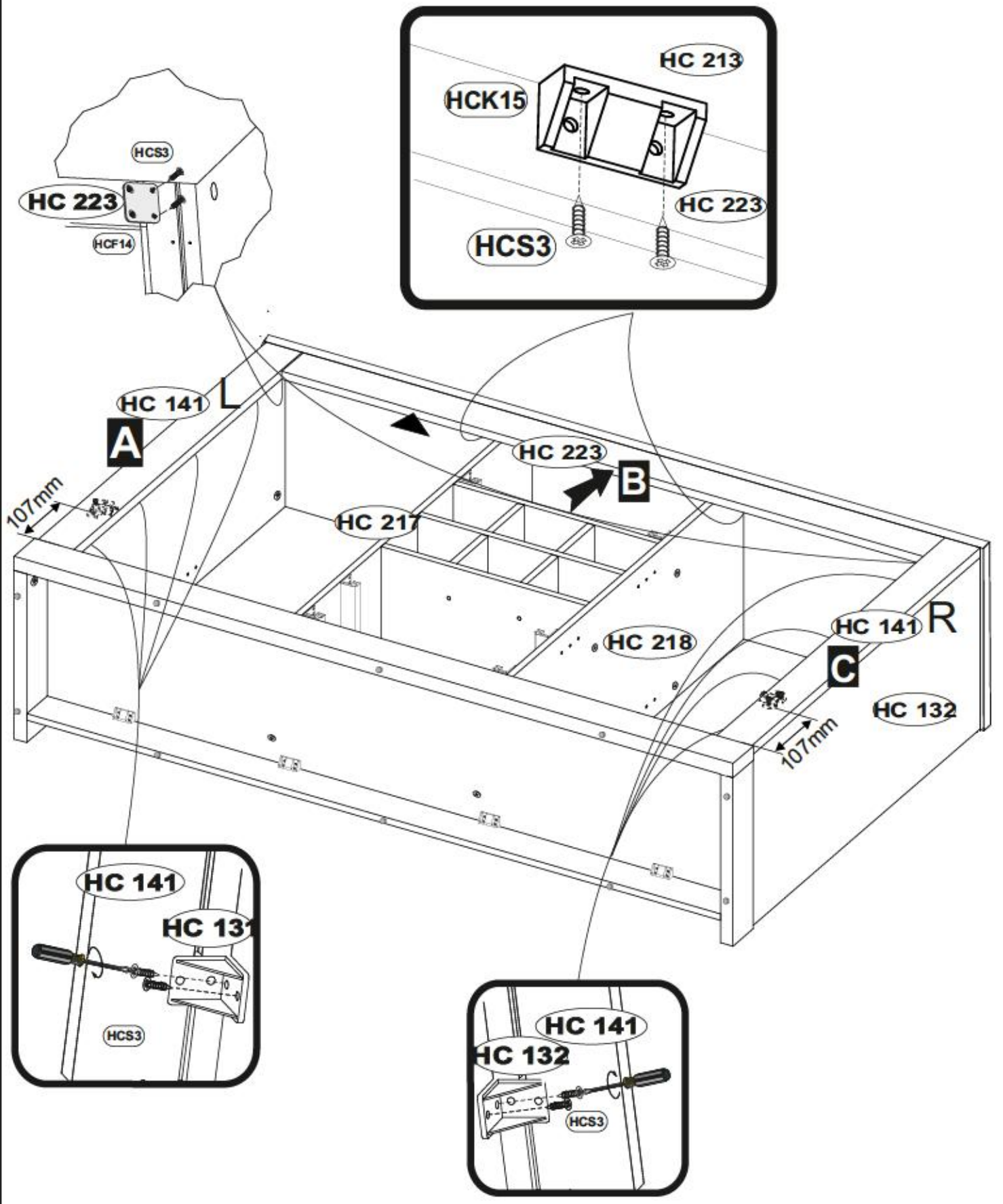



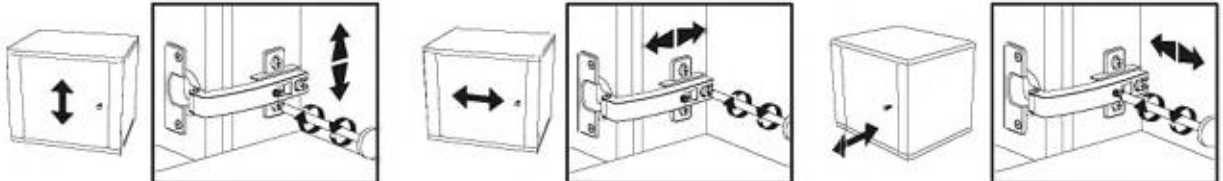
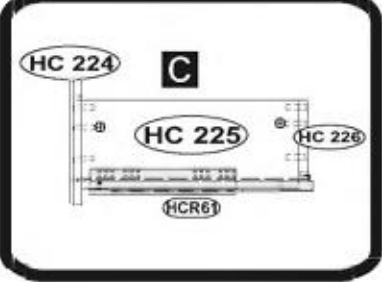
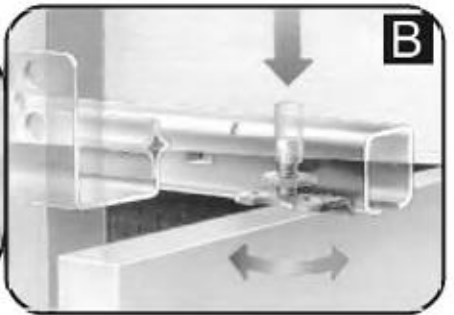
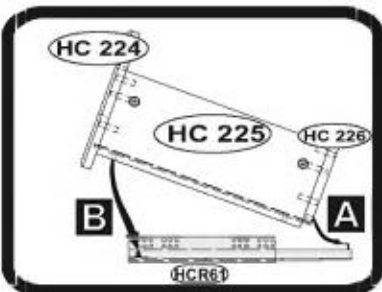
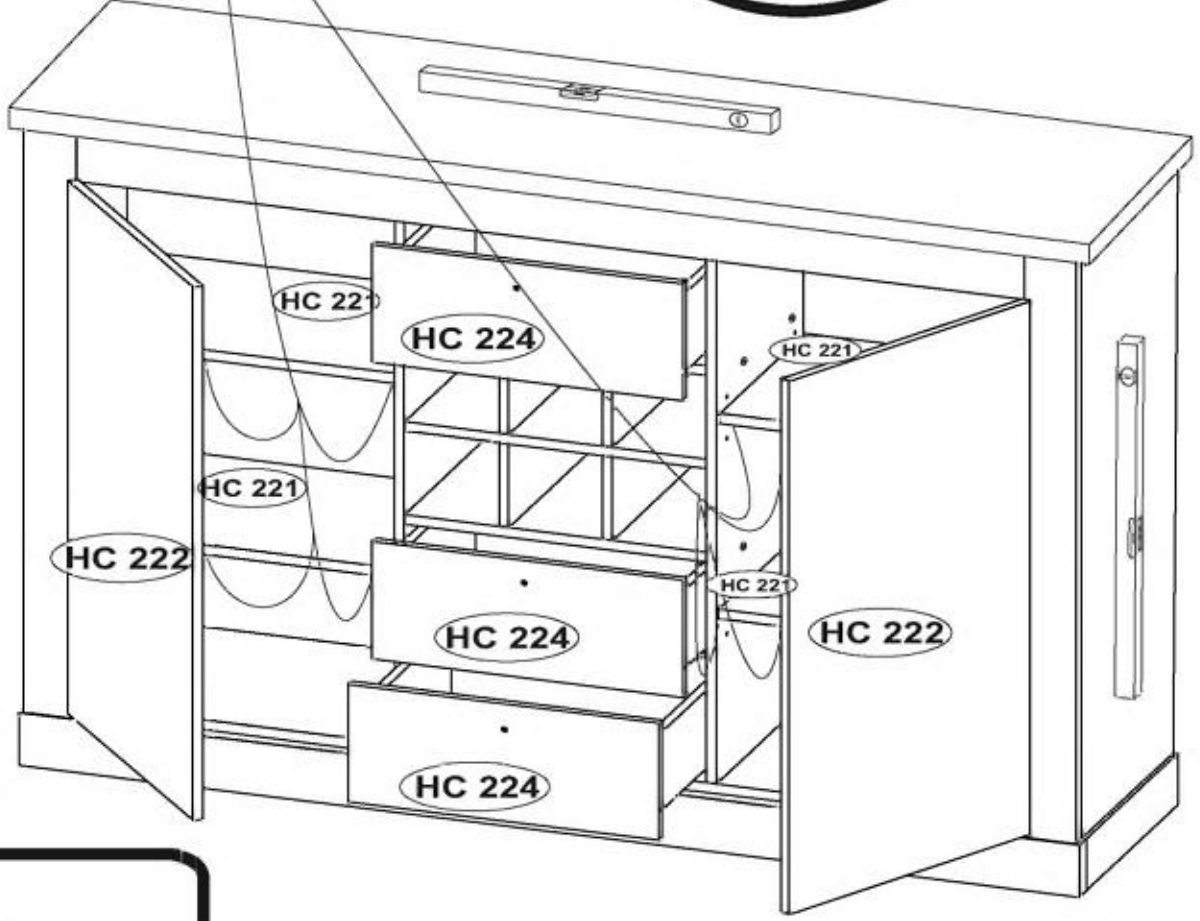
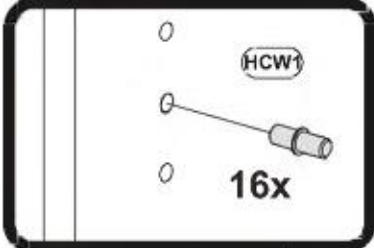

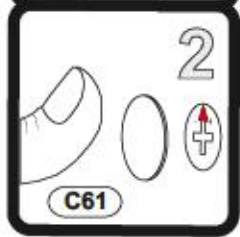
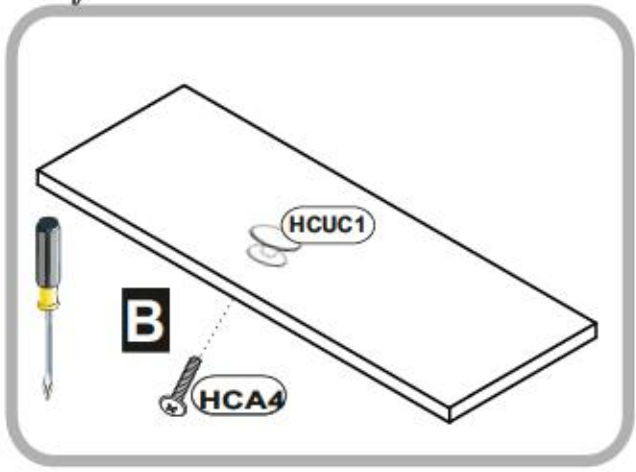
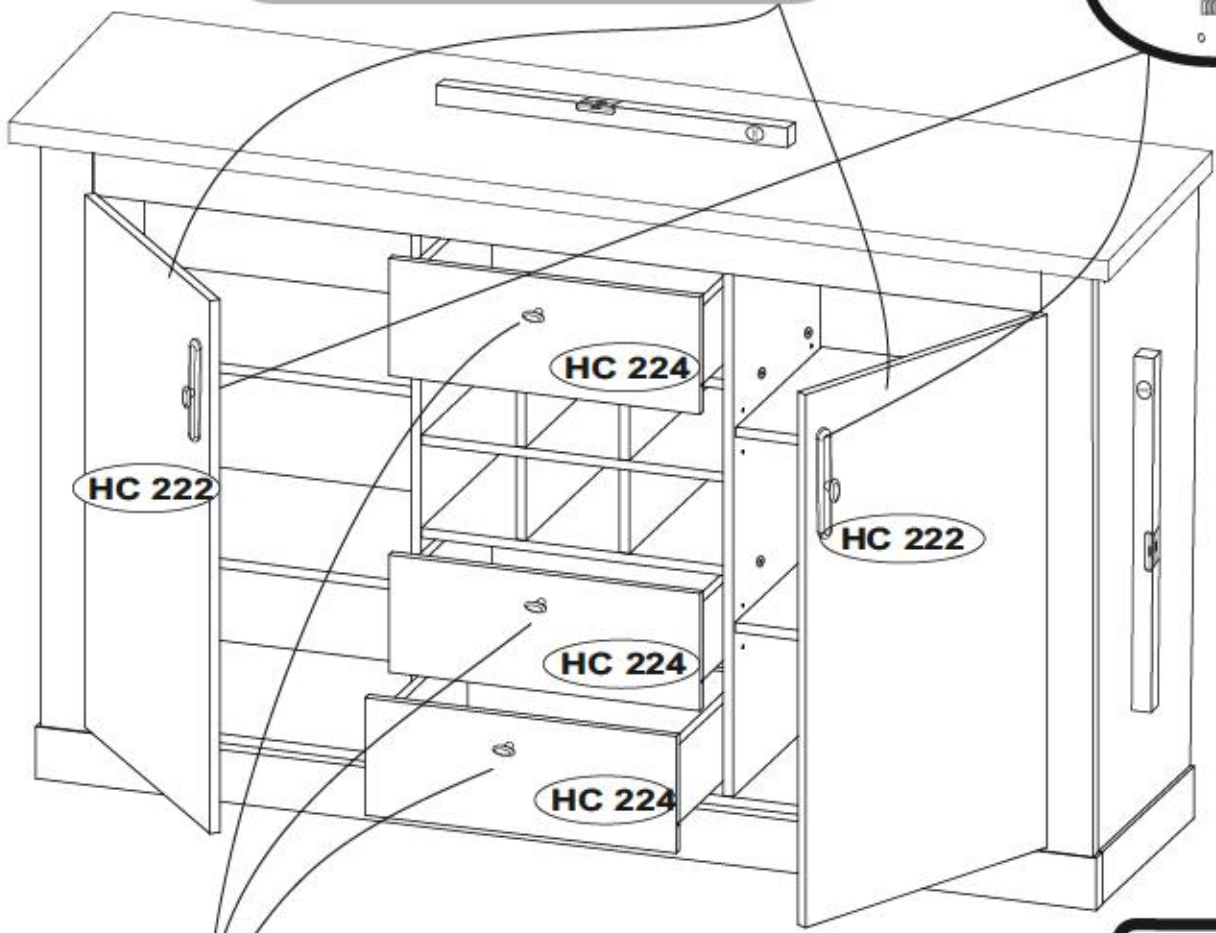
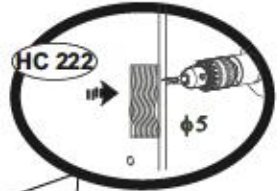
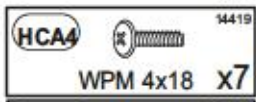
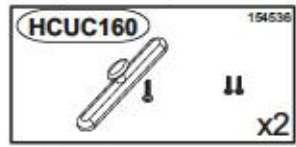
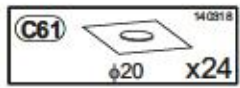
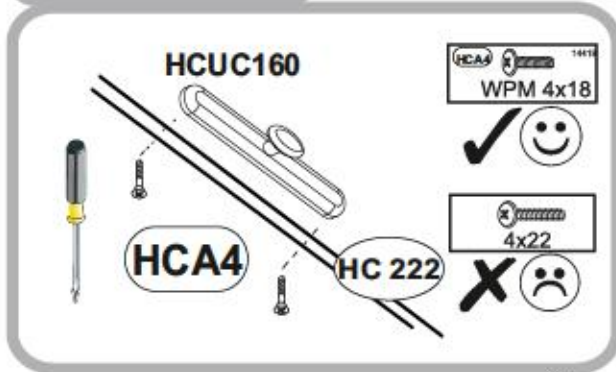
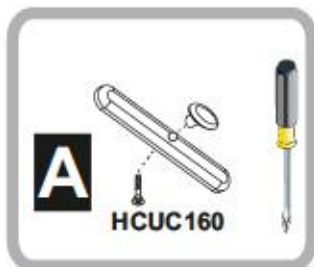

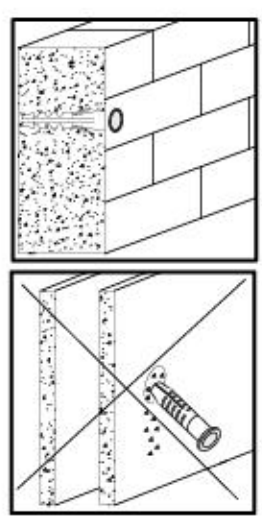
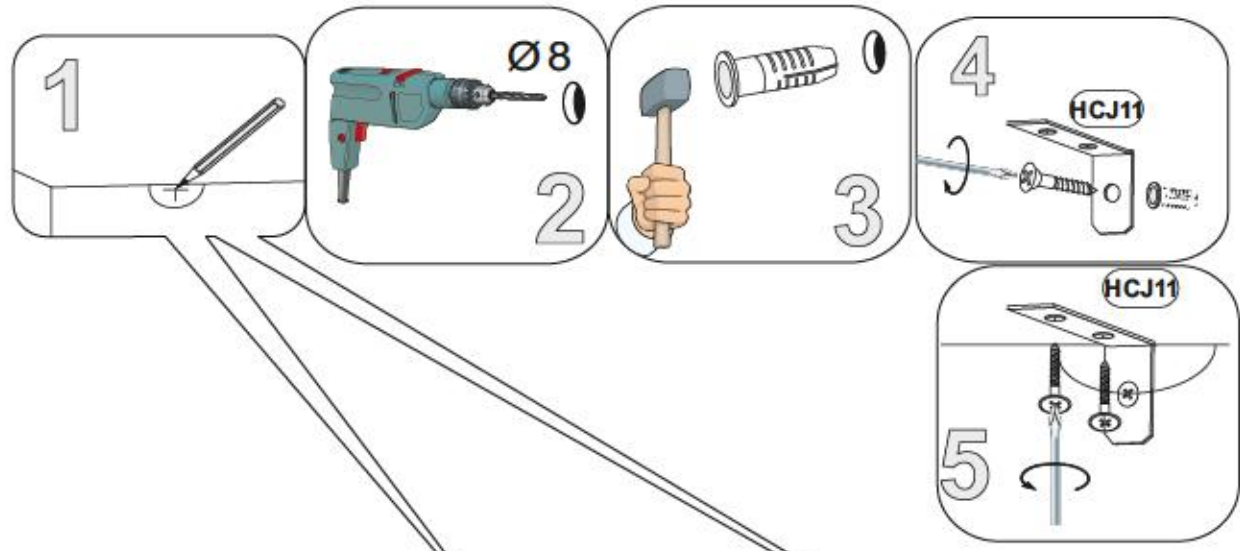



# RAVENNA 51

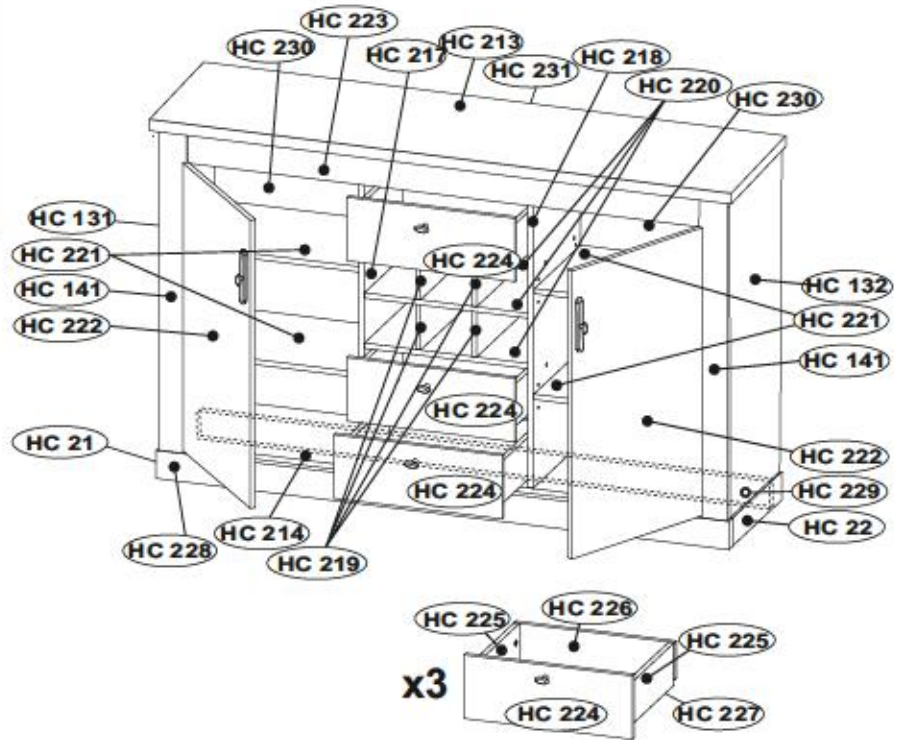

**D** Upper Directorate for Beech/glebe  
 Sollte Ihnen ein Beschädigte liegen, können Sie diese Servicekarte direkt an die untere Hand-Adresse mailen. Wir können allerdings nur Beschädigte auf diesem Wege verschicken. Sollten Sie eine andere Bezeichnung an Ihrem Möbelstück haben, so wenden Sie sich bitte direkt an Ihre Möbelhaus.

**GB** Our direct order service for fitting  
 If a fitting part is missing, you can e-mail this service card directly to the address below. However, we can only send fitting parts in this way. If you have any other cause for complaint concerning your item of furniture, please contact your furniture store directly.

**CZ** Náš přímý servis pro kování  
 Chybí-li vám nějaký díl z kování, můžete tuto servisní kartu odešlat e-mailem přímo na níže uvedenou adresu. Touto cestou však můžeme poslat jen díly kování. Pokud byste měli nějaký jiný druh nábytku, obraťte se přímo na svého prodejce nábytku.

**F** Bien sûr, nous pouvons vous envoyer directement la présente carte service à l'adresse e-mail indiquée ci-dessous. Cependant, ceci nous permet uniquement d'envoyer des pièces de rechange. Pour tout autre type de réclamation concernant votre meuble, veuillez contacter directement votre magasin d'ameublement.

**I** Il nostro servizio di rete per l'ordine delle forniture  
 Qualora vi dovesse mancare un pezzo di fissaggio, allora vi preghiamo di inviare questa cartolina servizio (in modo diretto) all'indirizzo sottostante. Possiamo inviare i pezzi di fissaggio solamente per mezzo di questo procedimento. Qualora dovete avere qualche altra reclamazione in merito al mobile, allora vi preghiamo di rivolgervi direttamente al Vostro Negozio di mobili.

**BG** Непосредствено поръчка на обнова  
 Ако липсват части от кovánek, можете да изпратите тази картичка директно на адреса по-долу. По този начин можем да доставим само запчастията за обнова. Ако установите други дефекти по мебелта, се съветваме да се обръщате към вашия магазин за мебелировка, от който сте закупили стаята.

**NL** Directe service voor reparatie  
 Wanneer er een onderdeel ontbreekt, kunt u deze servicekaart direct aan ons toesturen of e-mailen sturen. Wij kunnen langere tijd nog achterhalen welke onderdelen verloren zijn. Nadat u een ander probleem met uw meubel hebt, verzoeken wij u contact op te nemen met uw meubelwink.

**PL** Nasz bezpośredni serwis montażowy  
 Jeżeli brakuje jakiegoś elementu montażowego, prosimy o przesłanie nam niniejszej karty serwisowej na niżej podany e-mailowy. W ten sposób możemy przesyłać. Ponadto tylko elementy części. W przypadku innych reklamacji dotyczących mebla, prosimy zgłaszać się do własnego meblowego, w którym został dokonany zakup.

**HR** Servis za obnove  
 U slučaju da nedostaje neki od dijelova molimo vas da nas dođe u veštavanje mail adresom navedenom ovdje. Na ovaj način mogu se dostaviti samo dijelovi. U slučaju da imate i druge prigovore vezane uz komad namještaja molimo vas da se obratite (ravno trgovini) namještaja gdje je isti kupljen.

**HU** Közvetlen igénybejelentés  
 Ha hiányzik egy rész, azt a kövületi kártyával e-mail címen az alább látható címre. Azonban csak a visszaküldött kártyák igy küldeni. Amennyiben másfajta reklamációkat írnak bűntudatját írásban, forduljan közvetlenül a boltiáruházhoz.

**SK** Náš priamy servis pre kovanie  
 Ak by Vám chýbala nejaká časť kováni, môžete poslať túto servisnú kartu priamo e-mailom na nižšie uvedenú adresu. Chybí-li vám niektoré kováni, môžete poslať túto servisnú kartu priamo e-mailom na nižšie uvedenú adresu. Ak by ste mali iné reklamácie ohľadom Vašho nábytku, obráťte sa priamo na Vašu predajňu nábytku.

**SLO** Náš direkt servis za obnove  
 Če vam manjka kakikoli delov, lahko to sporočite na toleto pošiljate po e-pošti direktno na spodnji naslov. Po toleto lahko pošiljamo samo delov. Če imate kakikoli druge vrste pritožbe, se obrnite neposredno na vašo trgovino pohištva.

**RO** Serviciu directă pentru reparatie  
 În cazul în care vă lipseşte o piesă de înlocuire, puteţi să trimiteţi direct această card de serviciu prin e-mail la adresa de mai jos. Nu ne putem ocupa decât de furnizarea de piese de schimb. Dacă aveţi o altă reclamaţie referitoare la piesa de mobilier, atunci vă rugăm să vă adresaţi direct furnizorului dvs. de mobilier.

**RUS** Прямой сервис для поставки фурнитуры  
 Если отсутствует, что-либо из элементов кovánek, то вы можете отправить эту сервисную карточку по адресу, указанному ниже. Мы можем доставить только детали кovánek. Если у вас есть другая претензия относительно предмета мебели, пожалуйста, обратитесь непосредственно к продавцу.

**S** Vår direkteordre for beslagdelar  
 Om du saknar en beslagdel kan du skicka detta servicekort direkt till e-postadressen som anges nedan. Tänk på att detta är den enda möjligheten att skicka beslagdelar till dig. Om du vill reklamera din möbel annan anledning måste du kontakta ditt möbelslag direkt.

**ES** Nuestro servicio directo para accesorios  
 Si le falta algún accesorio, puede enviar esta tarjeta de servicio de mantenimiento a la siguiente dirección. No obstante, por este método solo podemos enviar accesorios. Si tiene alguna otra objeción sobre su mueble, consulte directamente con su mueblería.

**TR** Doğrudan sipariş verdiğimiz  
 Bir parçanın eksikliği veya servisini doğrudan aşağıdaki bulanan adrese doğrudan mail yoluyla istenebilir. Sadece bu yolla donatıları gönderilebilir. Mobilyanızda başka şikayetleriniz varsa diğer doğrudan mobilya satıcınıza danışın.

HC 21	x1	386	80	28	2/2	HC 221	x4	543	360	15	1/2
HC 22	x1	386	80	28	2/2	HC 222	x2	814	484	15	1/2
HC 131	x1	894	389	15	1/2	HC 223	x1	1455	74	18	2/2
HC 132	x1	894	389	15	1/2	HC 224	x3	477	180	15	2/2
HC 141	x2	894	80	22	1/2	HC 225	x6	313	125	15	2/2
HC 213	x1	1655	431	28	2/2	HC 226	x3	454	111	15	2/2
HC 214	x1	1583	369	15	2/2	HC 227	x3	435	334	2.5	2/2
HC 217	x1	879	368	15	1/2	HC 228	x1	1628	80	28	2/2
HC 218	x1	879	368	15	1/2	HC 229	x1	1570	80	28	2/2
HC 219	x4	126	366	15	1/2	HC 230	x2	899	558	2.5	1/2
HC 220	x3	464	367	15	2/2	HC 231	x1	899	478	2.5	1/2





# RAVENNA 71

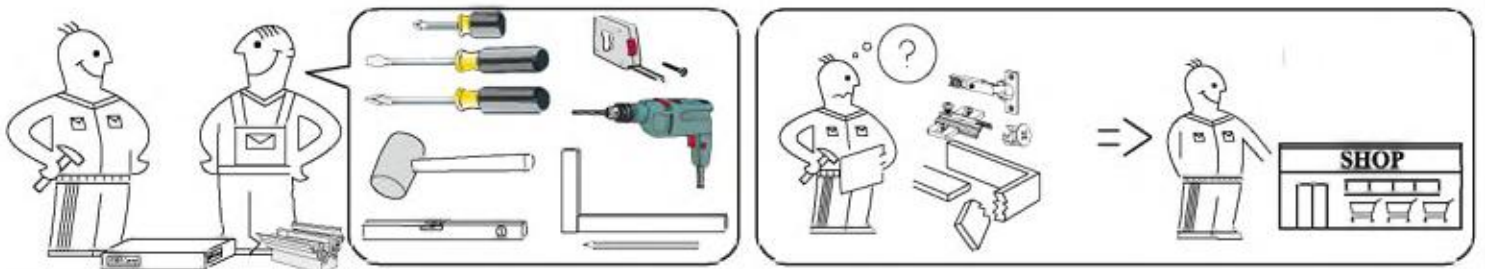
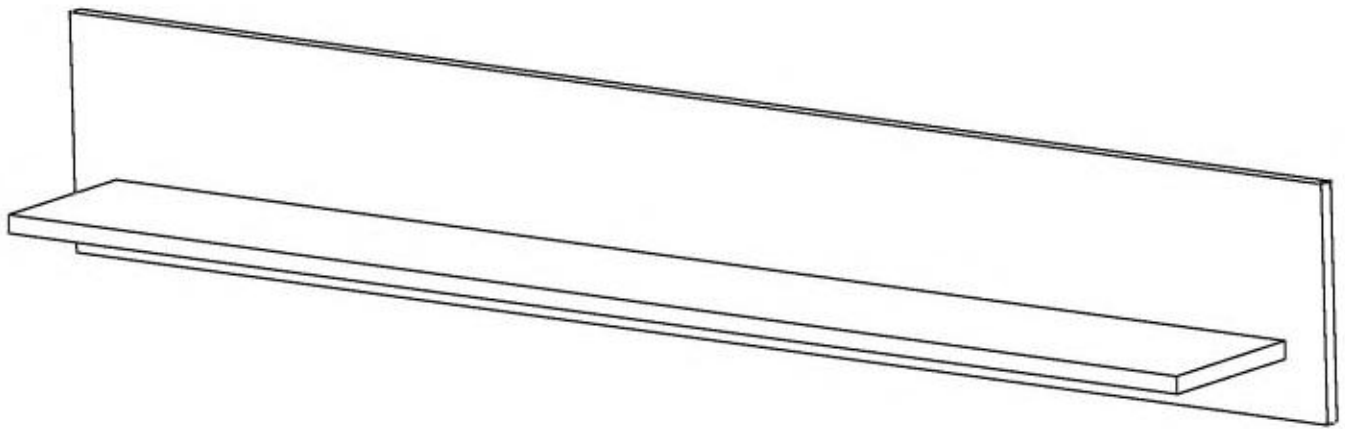

# RAVENNA 71

max.



**HC 56**

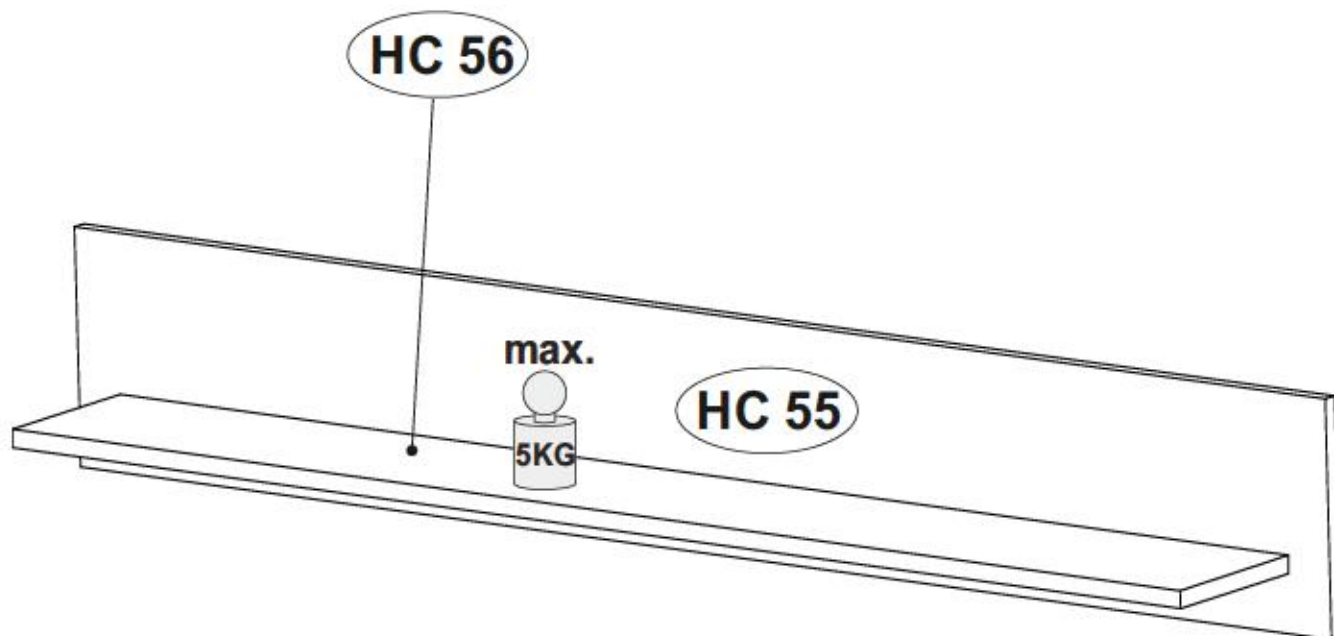

HC 55	x1	1500	200	15	1/1
HC 56	x1	1400	169	28	1/1

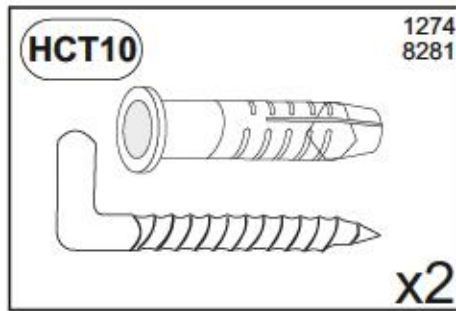
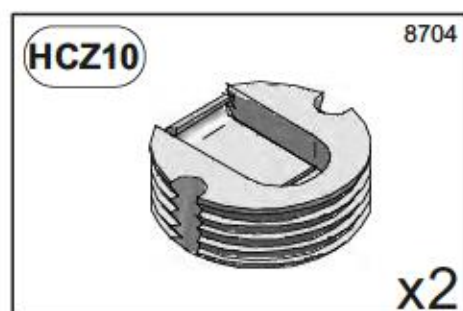
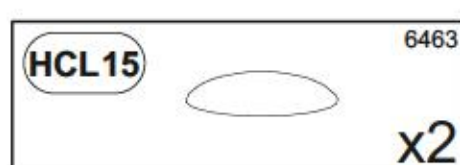
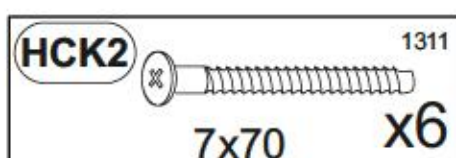

1

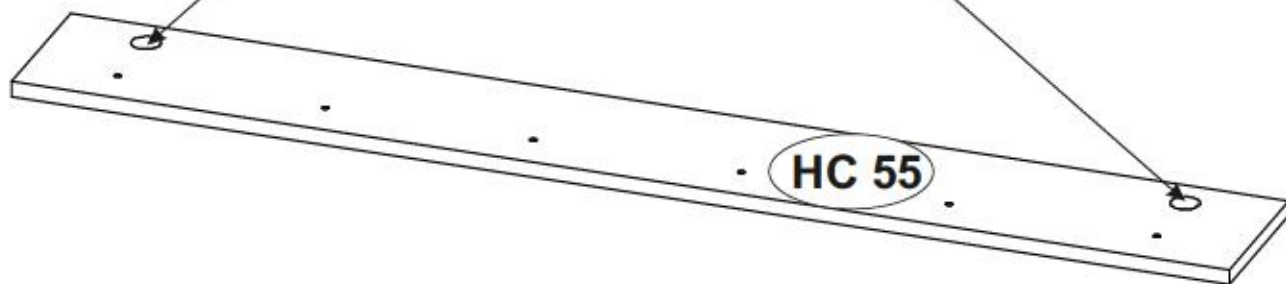
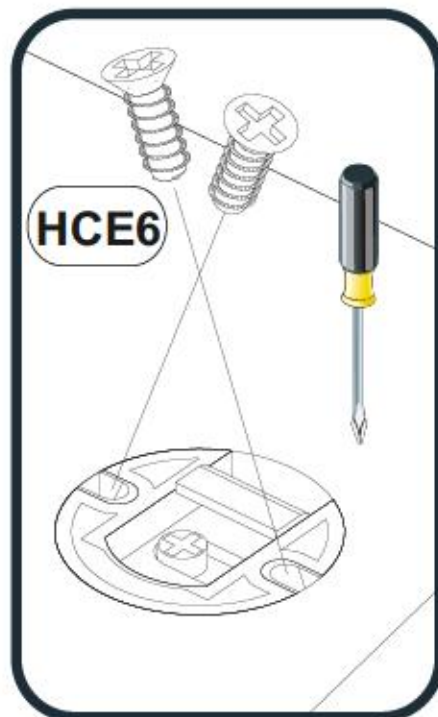
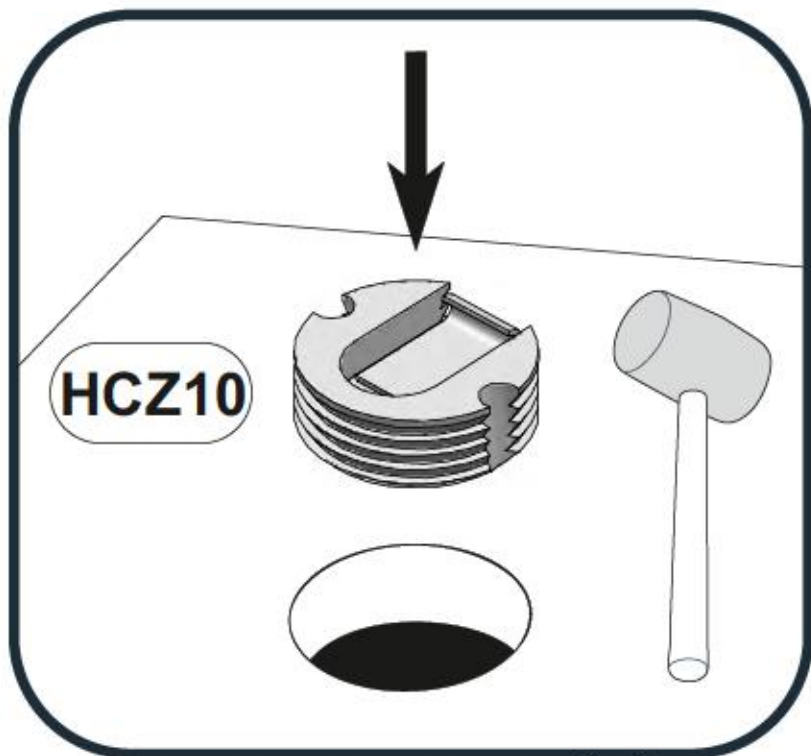
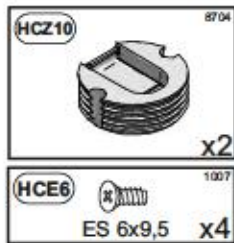



2

- HCK2 7x70 x6
- HCL15 9483 x2

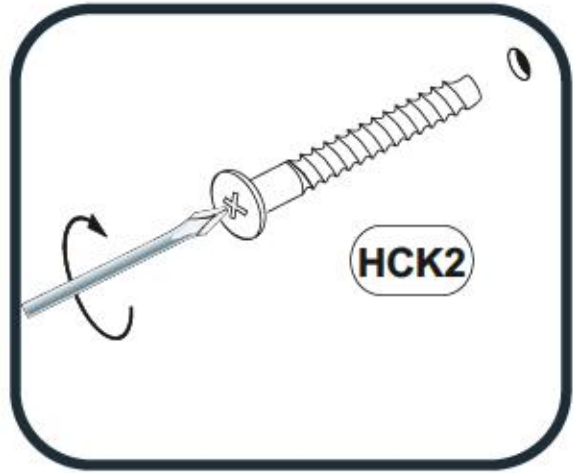
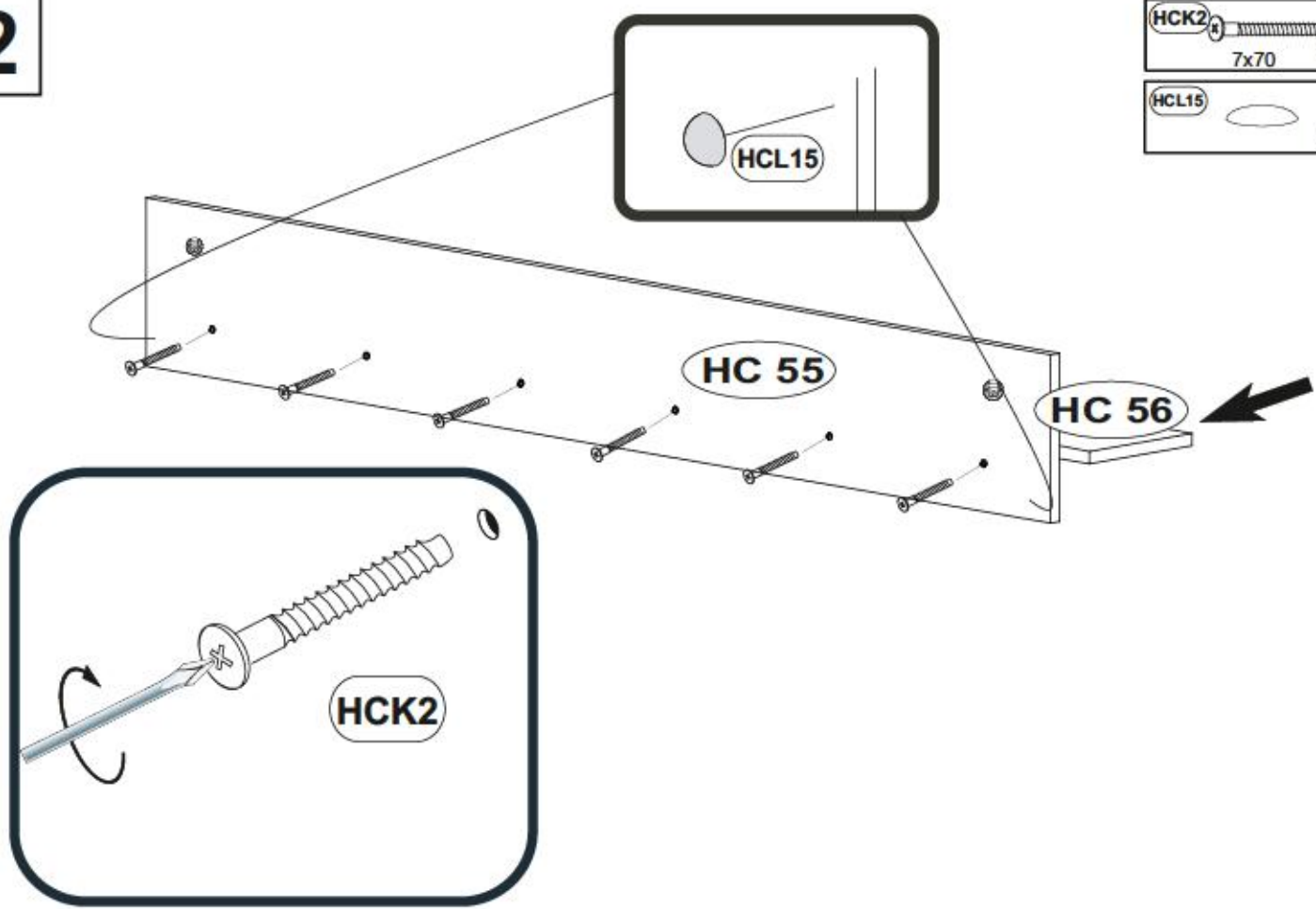

3

- HCT10 1274 8281 x2

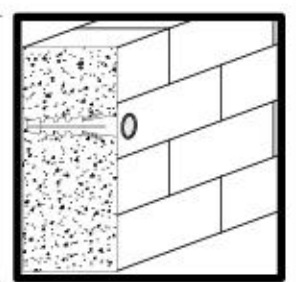
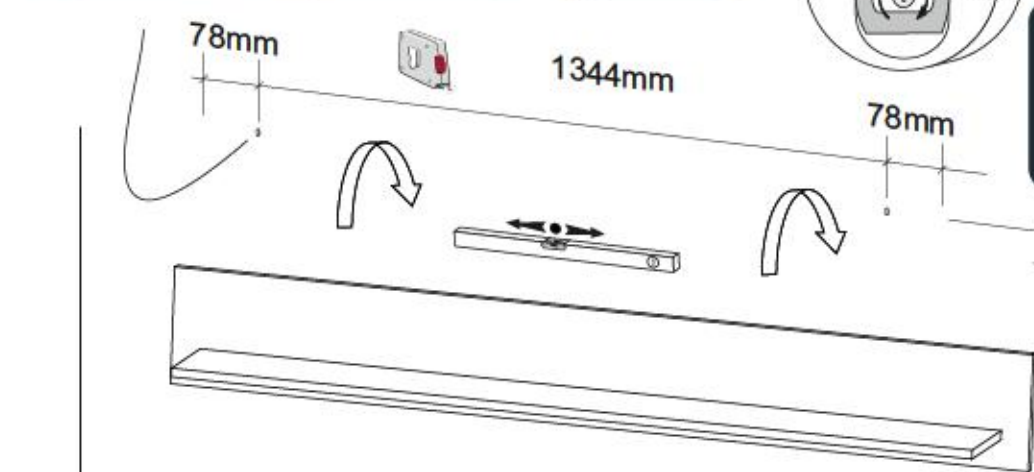
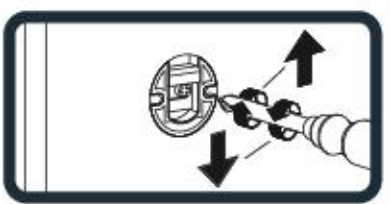
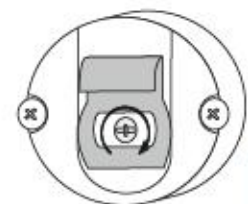
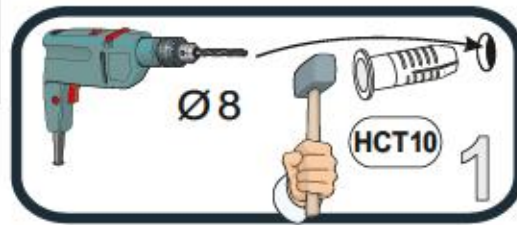

# RAVENNA 71

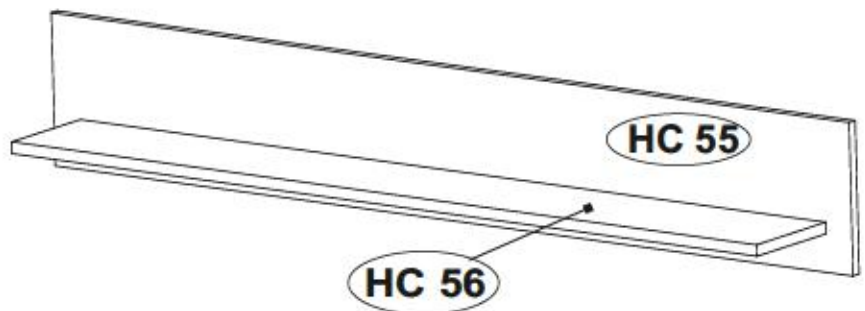

**D** Utwórz Drukowawcę lub Beesch bezpiele  
Sollte Ihnen ein Beschädigtes Teil, können Sie diese Servicekarte direkt an die untenstehende Adresse mailen. Wir können allerdings nur Beschädigte auf diesem Wege verschicken. Sollten Sie eine andere Beanstandung an Ihrem Möbelstück haben, so wenden sie sich bitte direkt an Ihre Möbelhaus.

**GB** Our direct and service for fitting  
If a fitting part is missing, you can e-mail this service card directly to the address below. However, we can only send fitting parts in this way. If you have any other cause for complaint concerning your item of furniture, please contact your furniture store directly.

**CZ** Naše přímá služba pro kování  
Chybí-li vám nějaký díl z kování, můžete tuto servisní kartu odeslat e-mailem přímo na níže uvedenou adresu. Toho ostatní však můžeme rozšířit jen díky kování. Pokud byste reklamovali jiný díl nábytku, obraťte se přímo na svého prodejce nábytku.

**F** Bien utiliser la notice de montage  
Si il vous manque une ferrure, veuillez envoyer directement la présente carte service à l'adresse e-mail indiquée ci-dessous. Cependant, ceci nous permet uniquement d'envoyer des ferrures. Pour tout autre type de réclamation concernant votre meuble, veuillez contacter directement votre magasin d'ameublement.

**I** Il nostro servizio diretto per l'ordine della ferramenta  
Qualora Vi dovesse mancare un pezzo di fissaggio, allora Vi preghiamo di inviare questa carta di servizio immediatamente all'indirizzo sottostante. Possiamo inviare in pezzi di fissaggio solamente per mezzo di questo procedimento. Qualora doveste avere qualche altra reclamazione in merito al mobile, allora Vi preghiamo di rivolgervi direttamente al vostro Negozio di mobili.

**BG** Прямата услуга за монтаж на обзавеждане  
Ако ви липне част от обзавеждането, потържете настоящата сервисна карта и не я пращайте на e-mail адреса, защото по-добре е от обзавеждането. Ако установите друга повреда по мебелите, се свържете директно с обзавеждания магазин.

**NL** Onze directe service voor het aanbrengen  
Wanneer er een onderdeel ontbreekt, kunt u deze servicekaart direct aan ons adres en e-mailadres sturen. Wij kunnen langzame weg echter alleen beschadigden verzenden. Mocht u een ander probleem aan uw meubel hebben, verzaken wij u contact op te nemen met uw meubeldealer.

**PL** Nasza bezpośrednia usługa montażowa  
Jeżeli brakuje części koniecznych do montażu, prosimy o przesłanie nam niniejszej karty serwisowej na niżej podany adres e-mailowy. W ten sposób możemy przesyłać jedynie uszkodzone części. W przypadku innych reklamacji dotyczących mebli, prosimy zgłosić się do naszego meblowego, w którym został do konan zakup.

**HR** Servis za uslugu  
U slučaju da nedostaje neki od dijelova meblu vas de ne doje navedenu mail adresu pošaljite ovaj servisni obrazac. Ne ovaj način mogu se dostaviti samo oštećeni. U slučaju da imate dodatne prigovore vezane uz komad namještaja molimo vas da se obratite izravno trgovini namještaja gdje je isti kupljen.

**HU** Direktusok a részletek hiányára  
Ha hiányzik egy részlet, azt a helyi értékesítőnél is kötheti az a részlet hiányát címre. Azonban csak a részleteket tudjuk így küldeni. Amennyiben másféle reklamációt állt lenn bátorodnánk a hiány, forduljon közvetlenül a boltjának.

**SK** Naše priamu službu pre štítu kovania  
Ak by Vám chýbala niekajá časť kovania, môžete poslať túto servisnú kartu priamo e-mailom na nižšie uvedenú adresu. Dňu kovania vieme poslať iba týmto spôsobom. Ak by ste mali inú reklamáciu ohľadom Vášho nábytku, obráťte sa priamo na Vašu predajňu nábytku.

**SLO** Naše direktna usluga za montažo  
Če vam manjka kakšno delce, lahko to serviso kartico pošljete po e-pošti direktno na spodnji naslov. Po želji pa vam lahko pošljemo samo oškodovane. Če želite reklamirati kakšen drug del pohištva, se obrnite neposredno na vašo trgovino pohištva.

**RO** Servisul direct pentru asamblare  
În cazul în care vă lipsește o piesă de mobilier, puteți să trimiteți direct această card de service prin e-mail la adresa de mai jos. Noi nu putem trimite pe această cale decât piese de mobilier avariate. Dacă aveți o altă reclamație referitoare la piesa de mobilier, atunci vă rugăm să vă adresați direct la magazinul dvs. de mobilier.

**RUS** Прямая служба для монтажа мебели  
Если окажется, что Вам не хватает того или иного элемента фурнитуры, Вы можете отправить сервисную карту по адресу непосредственно на наш производственный адрес электронной почты. Однако, таким образом мы можем предоставлять только фурнитуру. Если же у Вас возникнут иные претензии относительно приобретенной мебели, пожалуйста, обращайтесь непосредственно в магазин, осуществляющий продажу.

**S** Vår direkte service för beslag och delar  
Om du saknar en beslag eller kon du sakna de del servicekort direkt till e-postadressen som anges nedan. Men på ett delar och delar måste vi skicka till din beslag eller delar till dig. Om du vill reklamera din möbel av en annan anledning måste du kontakta ditt möbels butik.

**ES** Nuestro servicio directo para accesorios  
Si le falta algún accesorio, puede enviar esta tarjeta de servicio directamente a la siguiente dirección. No obstante, por este método solo podemos enviar accesorios. Si tiene alguna otra objeción sobre su mueble, consulte directamente con su mueblería.

**TR** Doğrudan hizmet için doğrudan servis kartı  
Bir donanım ya da aksesuar ya da servis kartını doğrudan aşağıdaki adrese doğrudan mail yoluyla bildirebilirsiniz. Sadece bu yolla donanım gönderilebilir. Mebelenize başka şikayetleriniz varsa diğer donanım taleplerinizi doğrudan mağazaya bildirmenizi öneririz.

HC 55	x1	1500	200	15	1/1
HC 56	x1	1400	169	28	1/1

# RAVENNA 71

**D** Unser Direktservice für Beschädigte  
Sollten Ihnen ein Beschädigtes fehlen, können Sie diese Servicekarte direkt an die untenstehende Adresse mailen. Wir können a landing nur Beschädigte auf diesem Wege verschicken. Sollten Sie eine andere Beschreibung an Ihrem Möbelstück haben, so wenden sie sich bitte direkt an Ihr Möbelhaus.

**GB** Our direct order service for fitting  
If a fitting part is missing, you can e-mail this service card directly to the address below. However, we can only send fitting parts in this way. If you have any other cause for complaint concerning your item of furniture, please contact your furniture store directly.

**CZ** Náš přímý službu pro kování  
Chybí-li vám nějaký díl z kování, můžete tuto službu i kartu adresát e-mailem přímo na níže uvedenou adresu. Tímto cestou však můžeme rozvést jen díly kování. Pokud byste měli jiné problémy, obraťte se přímo na svého prodejce nábytku.

**F** Bien servi en la notice de montage  
Si vous remarque une erreur, veuillez en voyer directement la présente carte ainsi que l'adresse e-mail indiquée ci-dessous. Cependant, ceci nous permet uniquement d'envoyer des pièces de rechange. Pour tout autre type de réclamation concernant votre meuble, veuillez contacter directement votre magasin d'ameublement.

**I** Il nostro servizio diretto per i condra delle forniture  
Qualora Vi dovesse mancare un pezzo di fissaggio, allora Vi preghiamo di inviare questa carta di servizio insieme alle istruzioni sotto elencate. Possiamo inviare i pezzi di fissaggio solamente per mezzo di questo procedimento. Qualora dovete avere qualche altra reclamo in merito al mobile, allora Vi preghiamo di rivolgerVi direttamente al Vostro Negozio di mobili.

**BG** Насят директен сервис за обнова  
Ако ви липне част от монтажната, потпишете нешто друго од сервисната карта и ја испратете на е-маил адресот, ние можеме да ви испратиме само деловите од обнова. Ако имате други проблеми со мебелот, се советуваме да се обратите кон вашиот продавач на мебелот, од којто сте купили мебелот.

**NL** Onze directservice voor de montage  
Wanneer er een onderdeel ontbreekt, kunt u deze servicekaart direct aan ons toesturen die meegezonden worden. Wij kunnen lange deze weg echter alleen beschadigden verzenden. Mocht u een ander probleem aan uw meubel hebben, verzaken wij u contact op te nemen met uw meubelwink.

**PL** Nasz bezpośredni serwis części montażowych  
Jeżeli brakuje części koniecznych do montażu, prosimy o przesłanie nam niniejszej karty wraz z adresem e-mailowym. W ten sposób możemy przesyłać. Prosimy tylko brakuje części. W przypadku innych reklamacji dotyczących mebla, prosimy zgłaszać się do sklepu meblowego, w którym został dokonany zakup.

**HR** Servis zaokona  
U slučaju da nedostaje neki od dijelova molimo vas da ne dajete novu adresu poštom već ovaj servisni obrazac. Na ovaj način mogu se dostaviti samo okona. U slučaju da imate dodatne prigovore vezane uz komad namještaja molimo vas da se obratite izvorno trgovini na mjestu gdje je isti kupljen.

**HU** Direktrendelésért a csatlakozásokért  
Ha hiányzik egy csatlakozó, azt a kártyát közvetlenül e-közvetlenül az alábbi e-mail címre. Azonban csak a csatlakozókat tudunk így elküldeni. Amennyiben más problémák merülnek fel a furnitúrát illetően, forduljon közvetlenül a bolti eladóhoz.

**SK** Náš přímý servis pro čisti kování  
Ak by Vám chýbala niekajá časť kování, môžete poslať túto službu i kartu adresát e-mailom na nižšie uvedenú adresu. Týmto spôsobom však môžeme rozveš iba kování. Ak by ste mali iné problémy s nábytkom, obráťte sa priamo na Vašu predajňu nábytku.

**SLO** Náš přímý servis zaokona  
Če vam manjka kakikoli delov, lahko to servisu i karti pošljete po e-pošti direktno na spodnji naslov. Po tej poti vam lahko pošljemo samo okona. Če želite reklamirati kakšen drug del pohištva, se obrnite neposredno na vašo trgovino pohištva.

**RO** Servisul direct pentru furnitură  
În cazul în care vă lipsește o piesă de furnitură puteți trimiteți această card de service prin e-mail la adresa de mai jos. Noi nu putem expedia piese de furnitură decât pe această cale. Dacă aveți o altă reclamație referitoare la piesa de mobilier, atunci vă rugăm să vă adresați direct la magazinul dvs. de mobilier.

**RUS** Наш прямой сервис для поставки фурнитуры  
Если отсутствует, что Вам не хватает того или иного элемента из фурнитуры, Вы можете отправить сервисную карту по адресу непосредственно на нижеприведенный адрес электронной почты. Однако, только в этом случае мы сможем доставить только фурнитуру. Если же у Вас имеются иные претензии относительно приобретенной мебели, пожалуйста, обращайтесь непосредственно в орган розничной, откуда заказывали и приобрели.

**S** Vår direkte service for beskadigede  
Om du sakner en beskadigede kan du skicka detta servicekort direkt till e-postadressen som anges nedan. Tänk på att det är den enda möjligheten att skicka beskadigede till dig. Tänk på att du vill reklamera in i möbeln av en annan anledning än för skadorna till ditt möbelhus direkt.

**ES** Nuestro servicio directo para accesorios  
Si le falta algún accesorio, puede enviarnos este tarjeta de servicio de reemplazo a la siguiente dirección. No obstante, por esta vía no podemos enviar accesorios. Si tiene alguna otra objeción sobre su mueble, consulte directamente con su mueblería.

**TR** Doğrudan hizmet için servis kartı  
Bir donanım eksikliği veya servise kartını doğrudan aşağıdaki bulunan adrese doğrudan mail ile gönderebilirsiniz. Sadece bu yolla donanım parçalarını gönderebiliriz. Mobilyanızla ilgili diğer problemlerinizi doğrudan mobilya satıcınıza danışın.

**HCZ10** 8704



X...

**HCL15** 6463



X...

**HCK2** 1311



7x70 X...

**HCT10** 1274  
8281

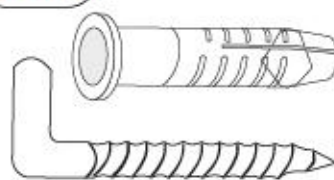

X...

**HCE6** 1007



ES 6x9,5 X...

