

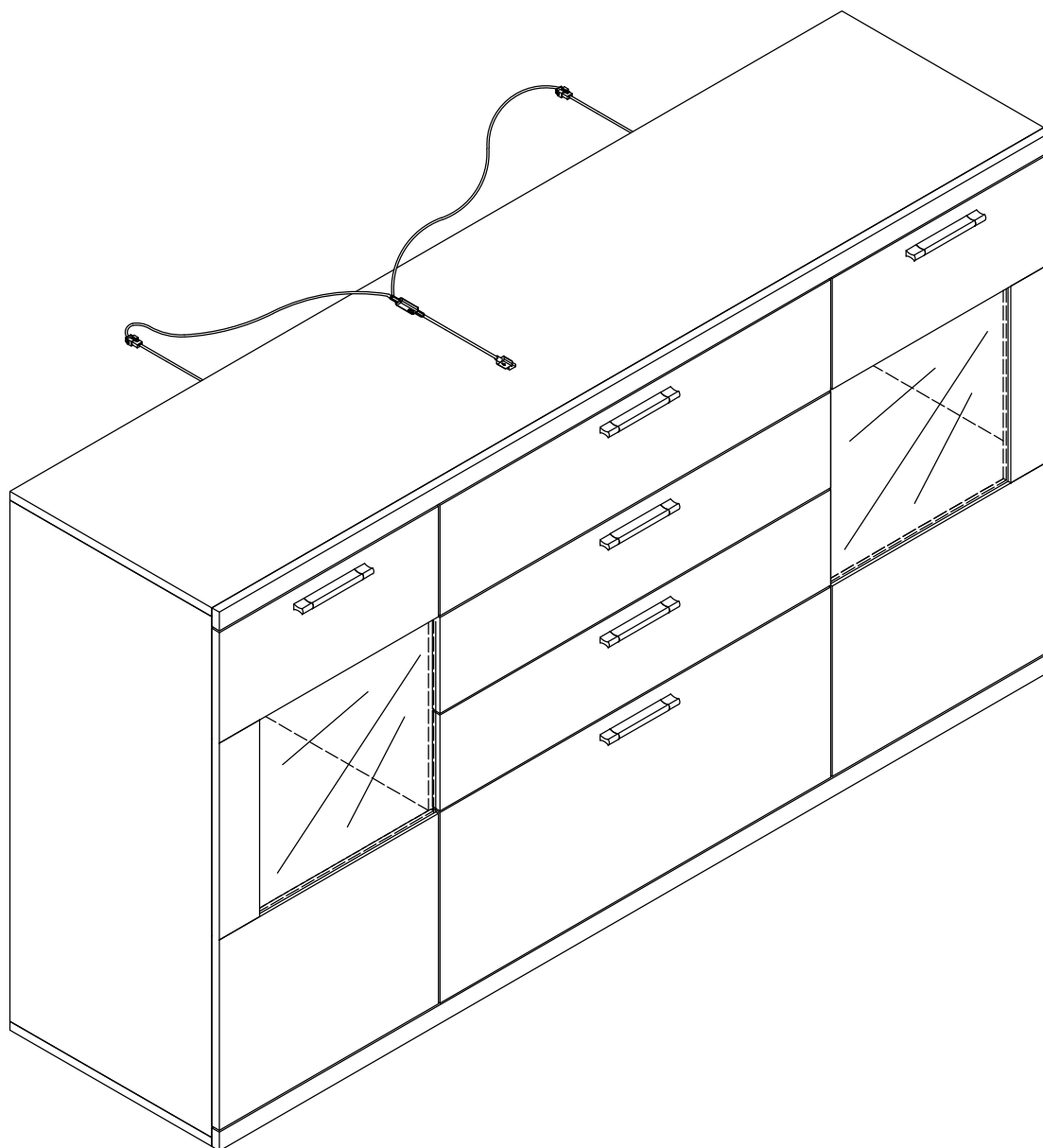



# ASSEMBLY INSTRUCTIONS

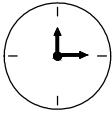
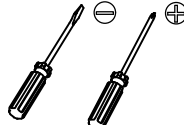
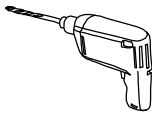
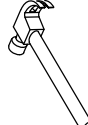

Packing Details: 3 Boxes In Total	
Box-1/3	WF296767
Box-2/3	WF296768
Box-3/3	WF296769

 2PERS	 120MIN	Tool Required Not Provided					
							

# Parts list

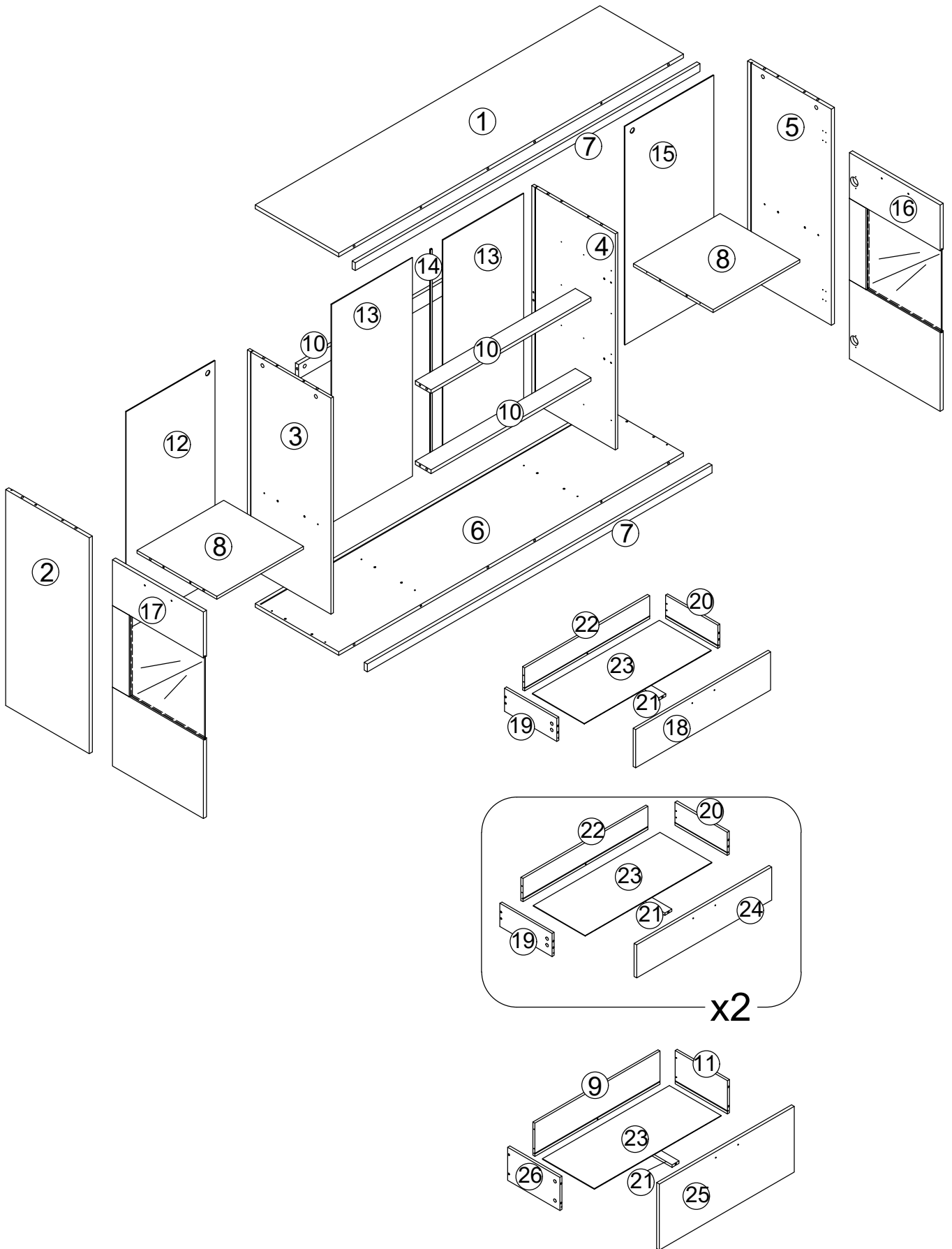

① x1

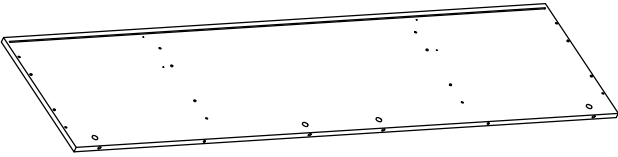

② x1

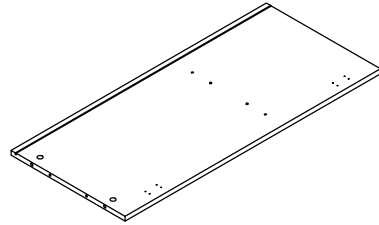

③ x1

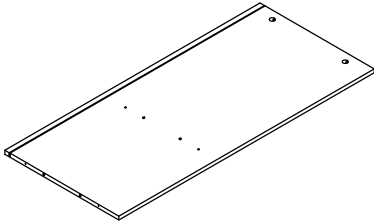

④ x1

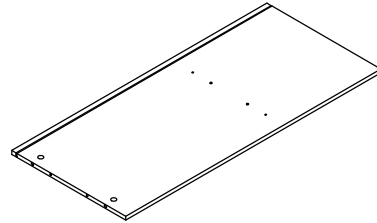

⑤ x1

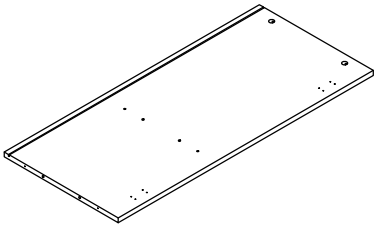

⑥ x1

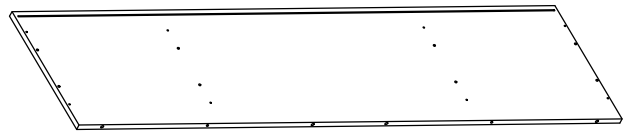

⑦ x2



⑧ x2

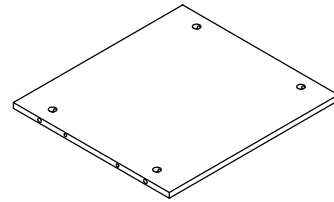

⑨ x1

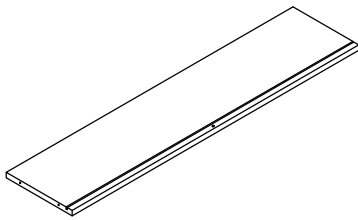

⑩ x3

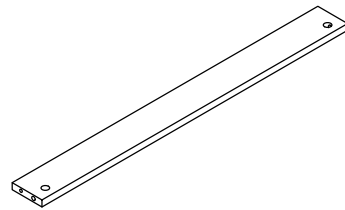

⑪ x1

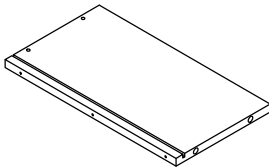

⑫ x1

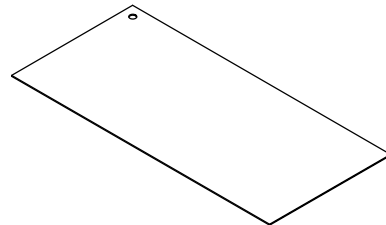

⑬ x2

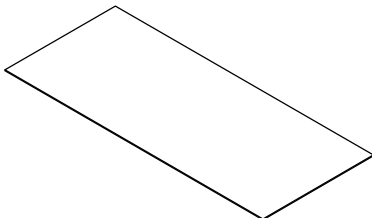

⑭ x1

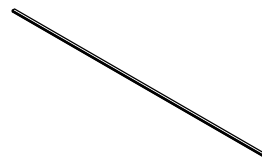

⑮x1

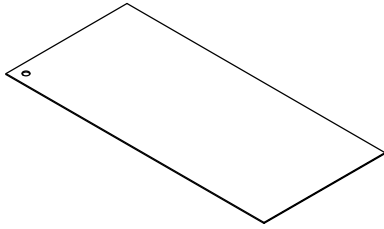

⑯x1

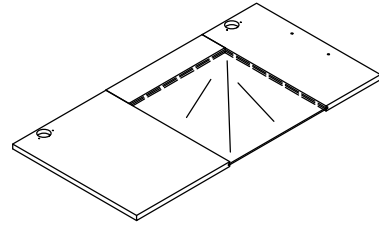

⑰x1

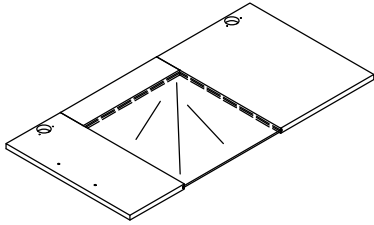

⑱x1

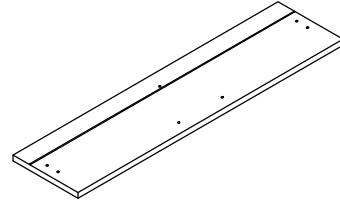

⑲x3

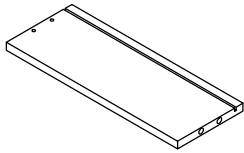

⑳x3

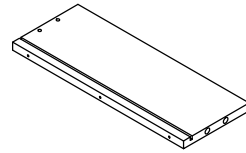

㉑x4

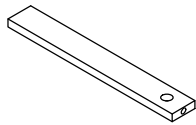

㉒x3

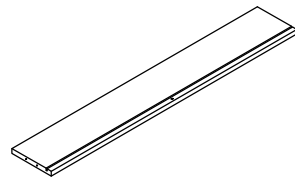

㉓x4

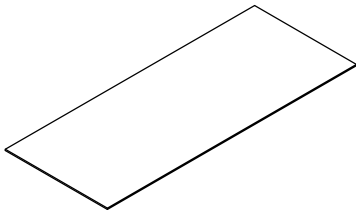

㉔x2

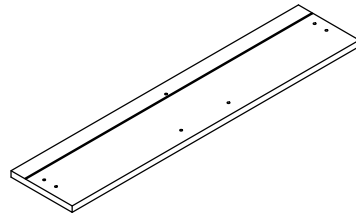

㉕x1

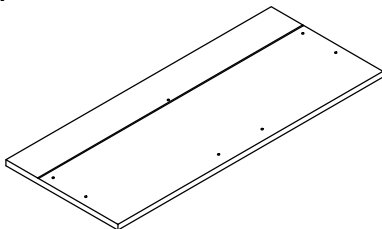

㉖x1

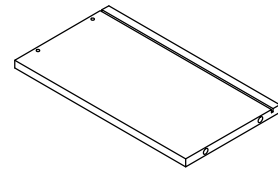



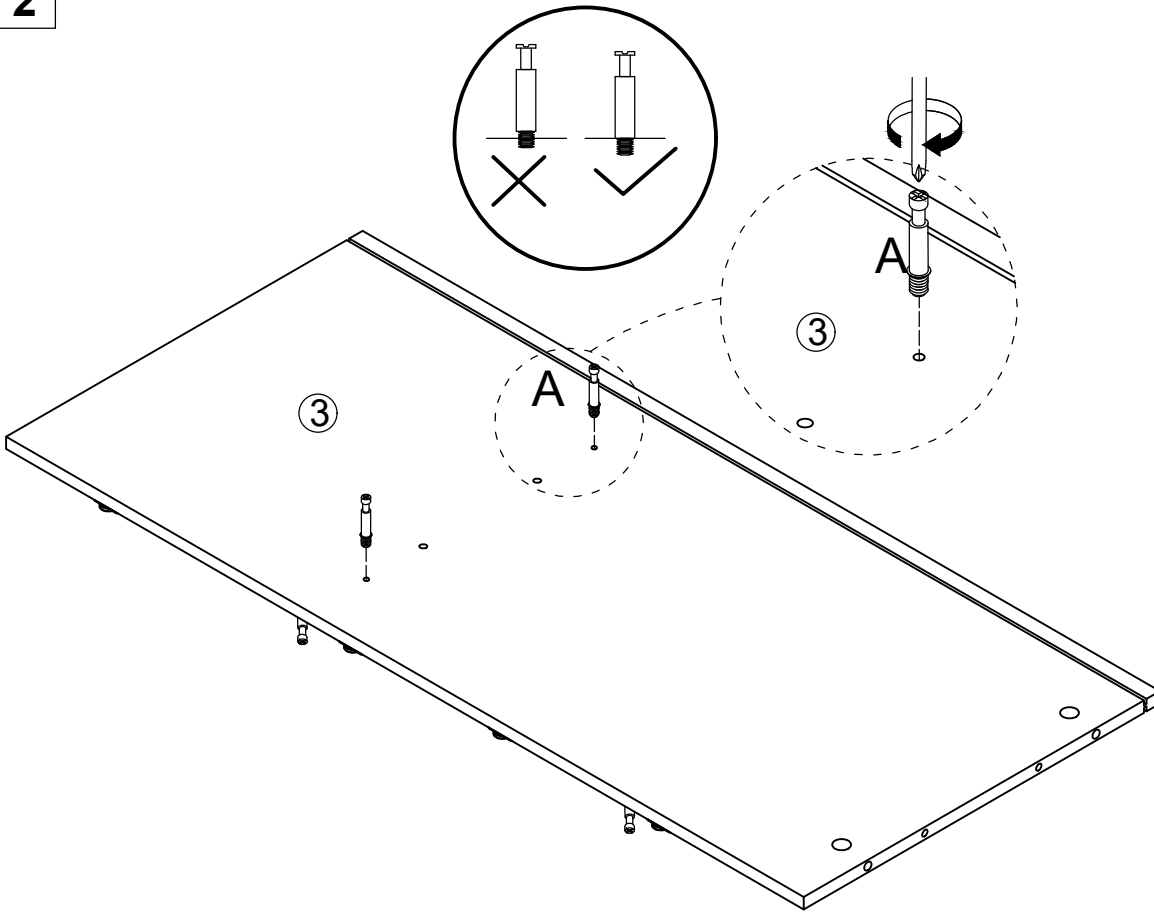

2

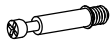

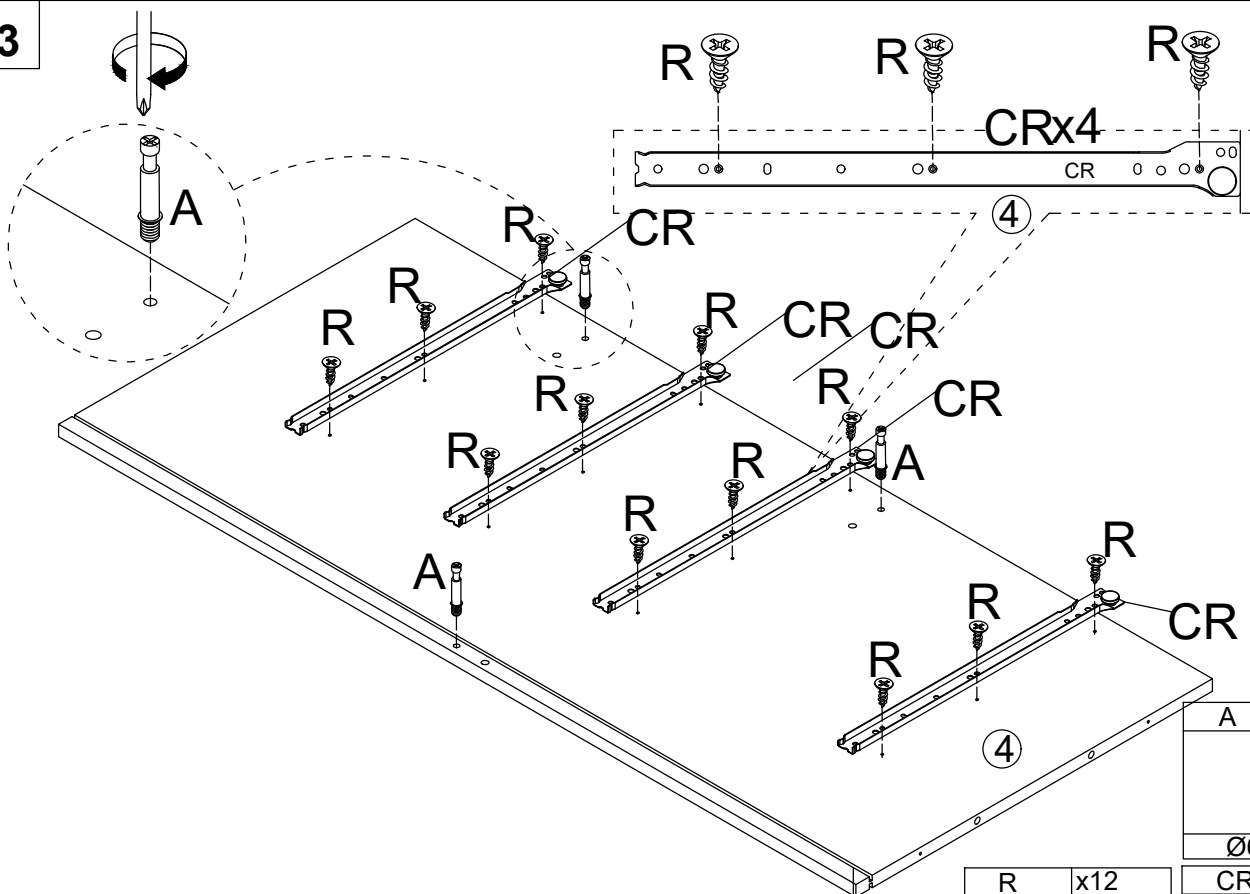

A	x2
	
Ø6x35mm	

3

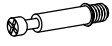

R	x12
	
Ø3.5x10mm	

A	x3
	
Ø6x35mm	
CR	x4
	
L300mm	

4

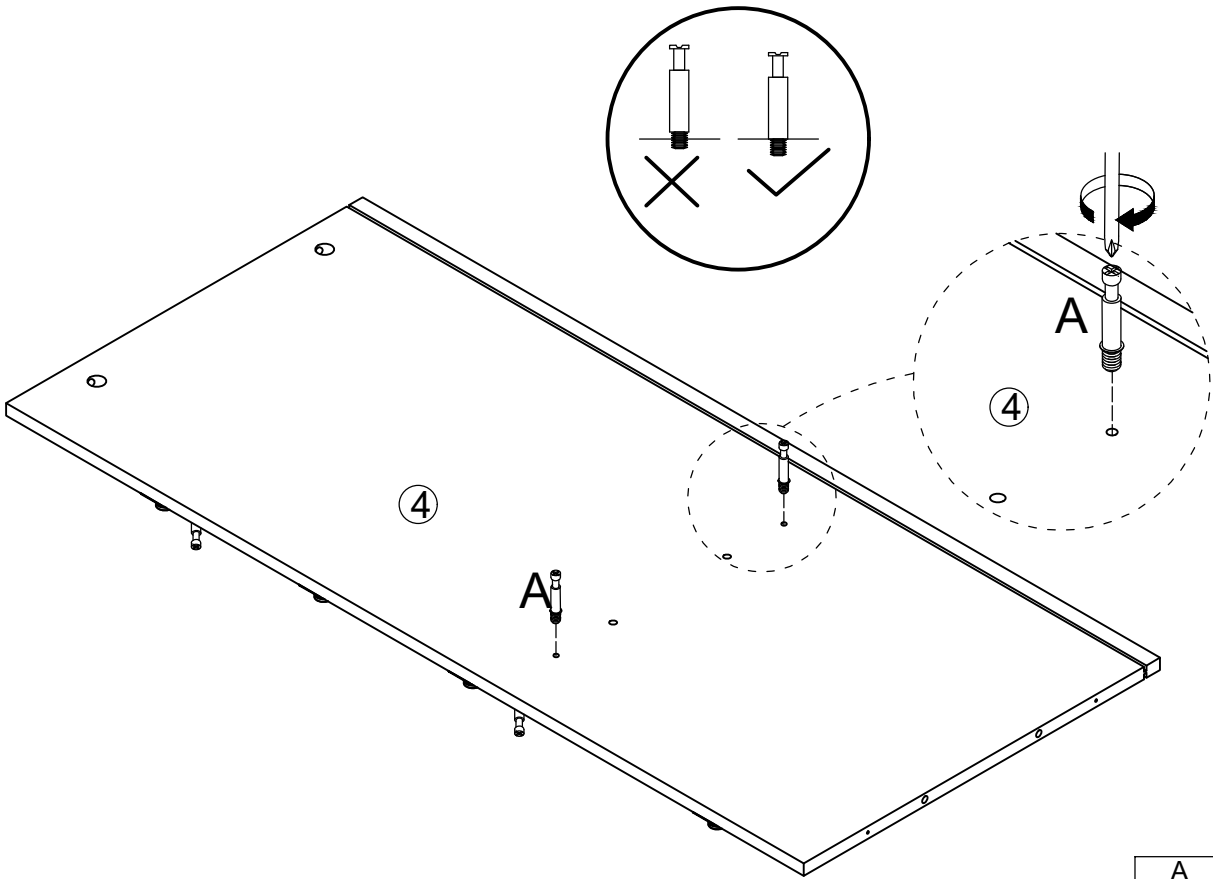

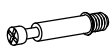
A	x2
	
Ø6x35mm	

5

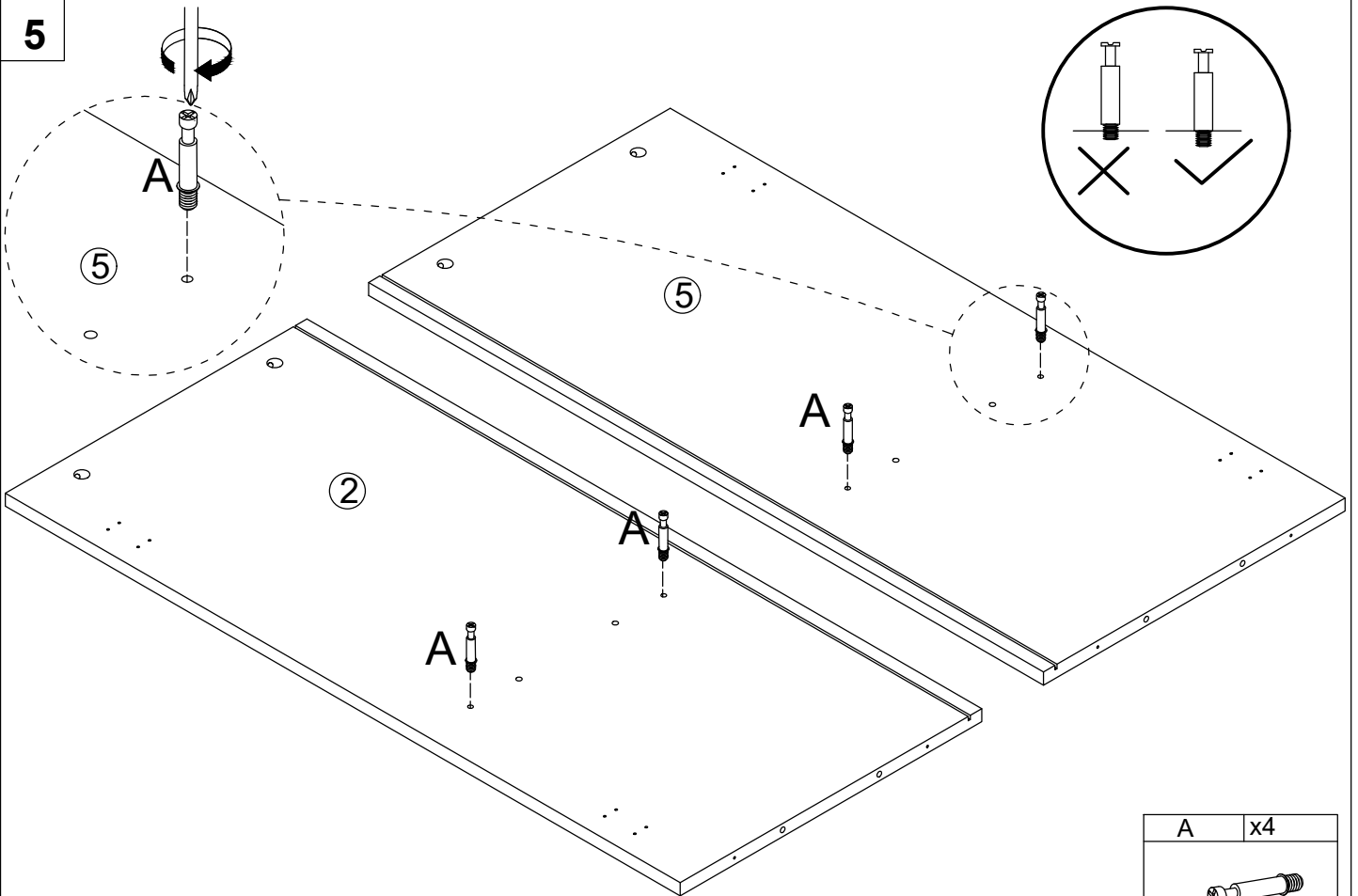

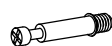

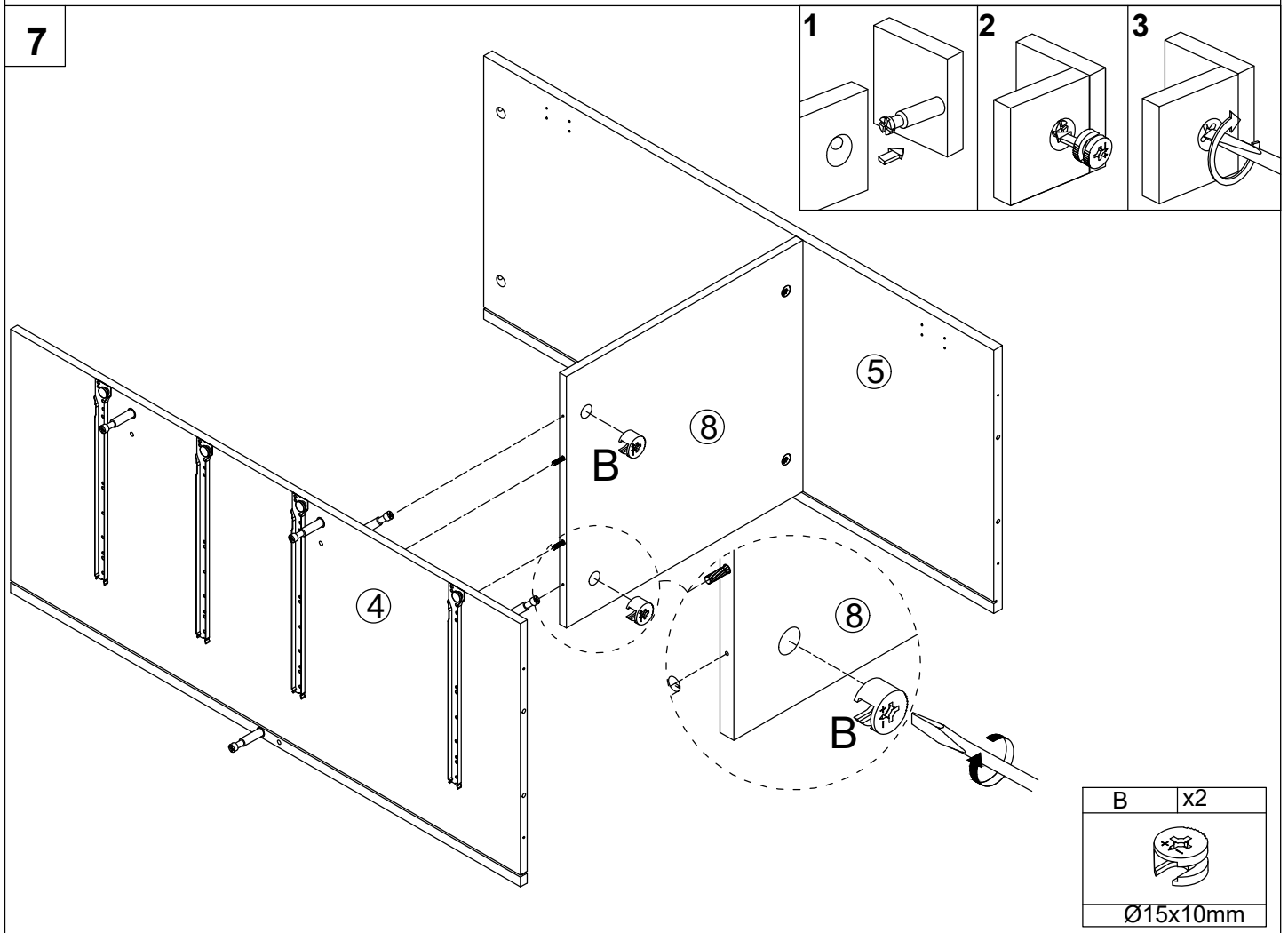
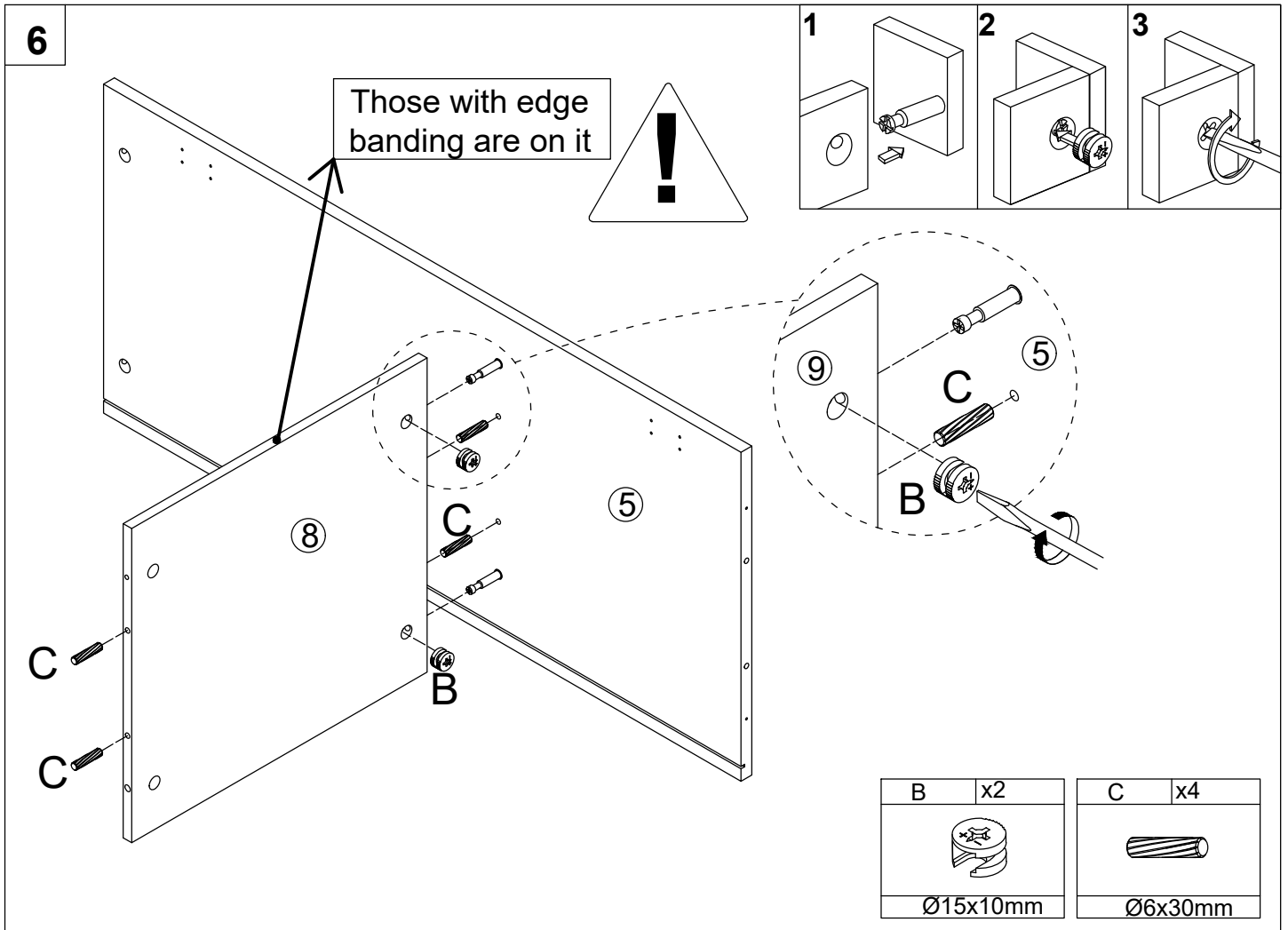
A	x4
	
Ø6x35mm	



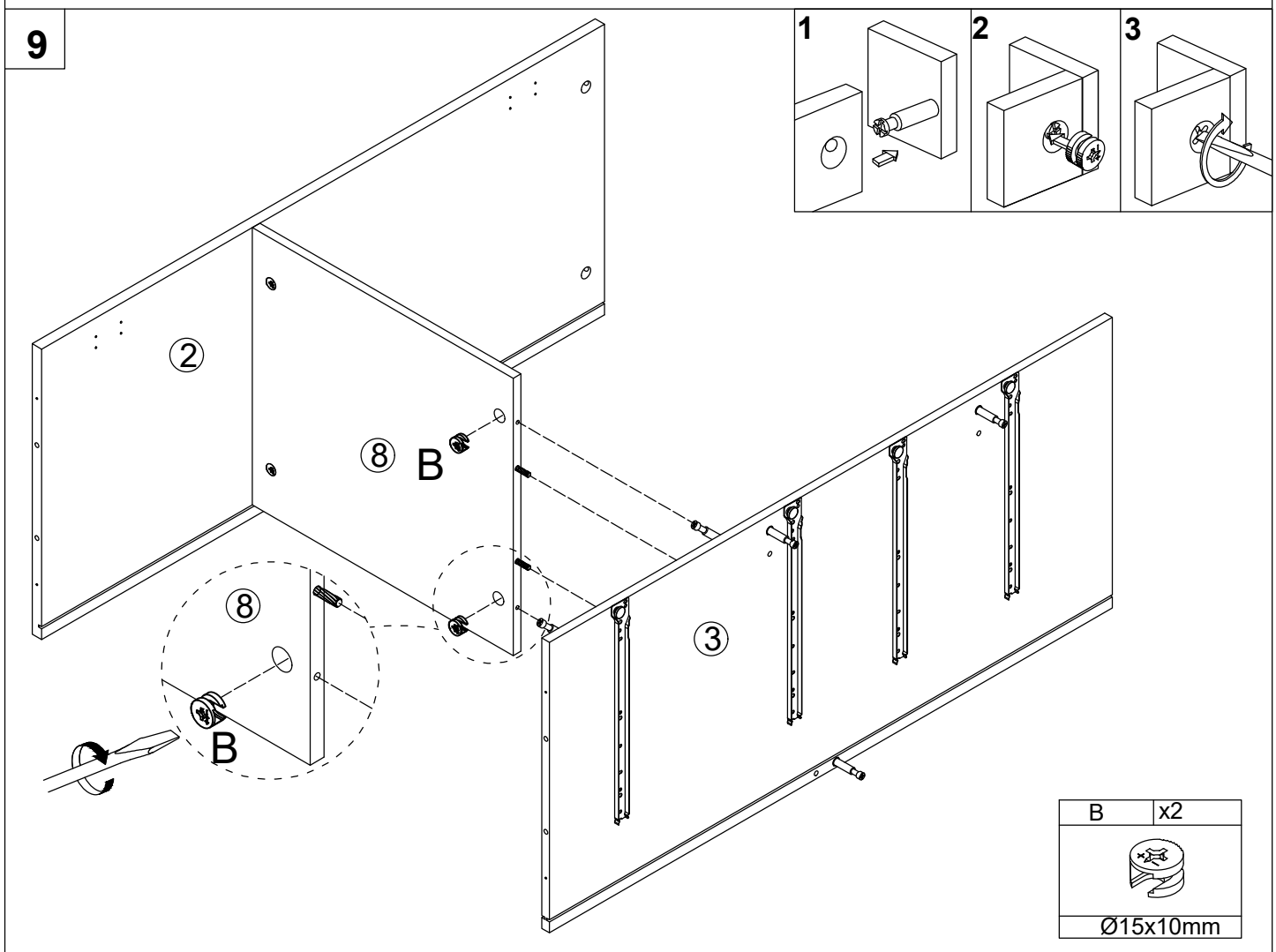
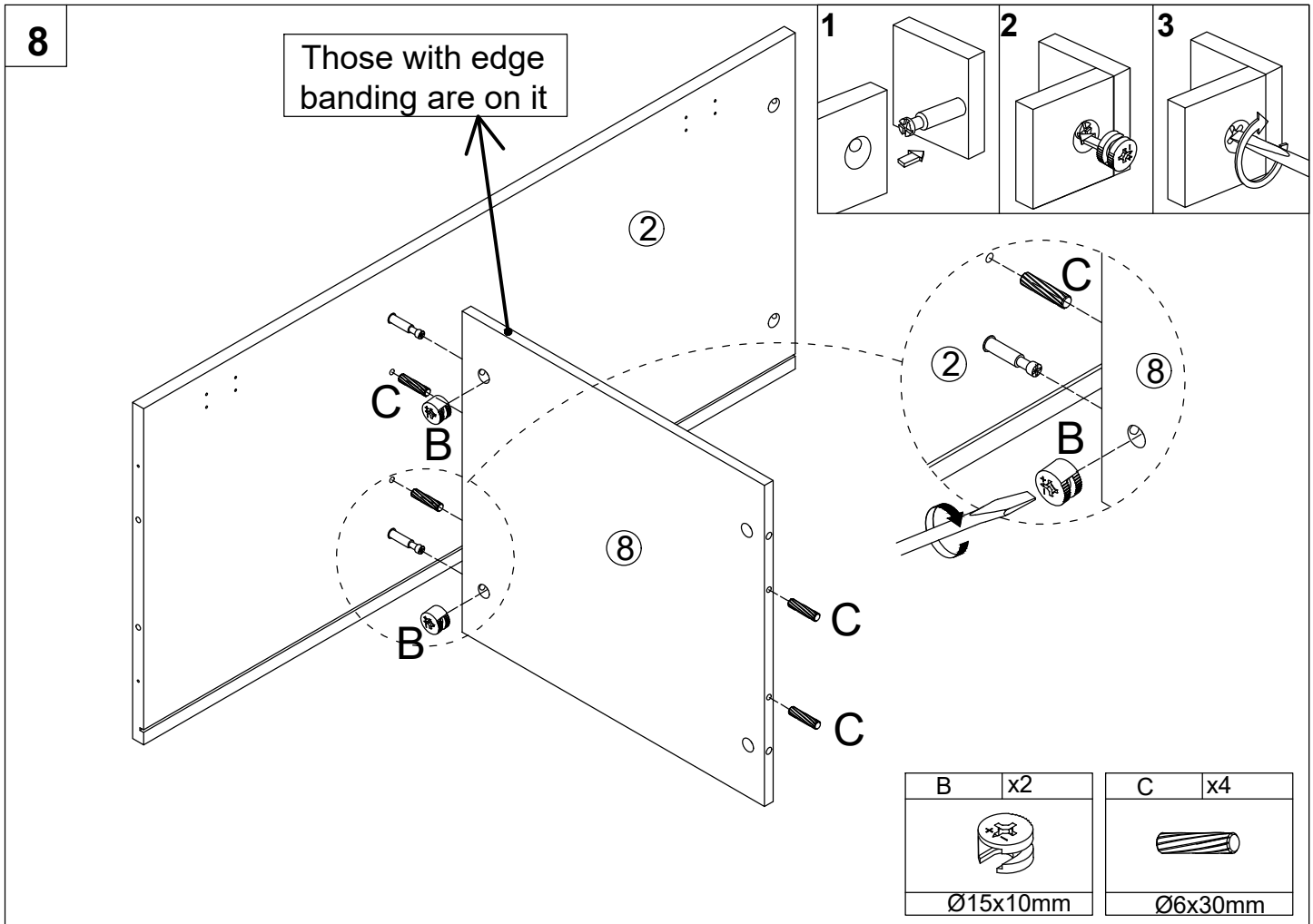

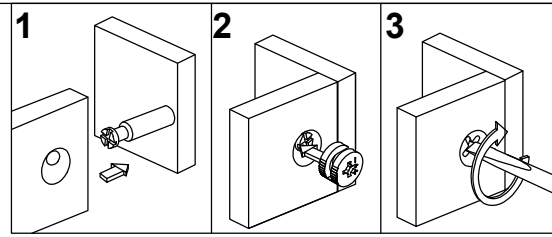
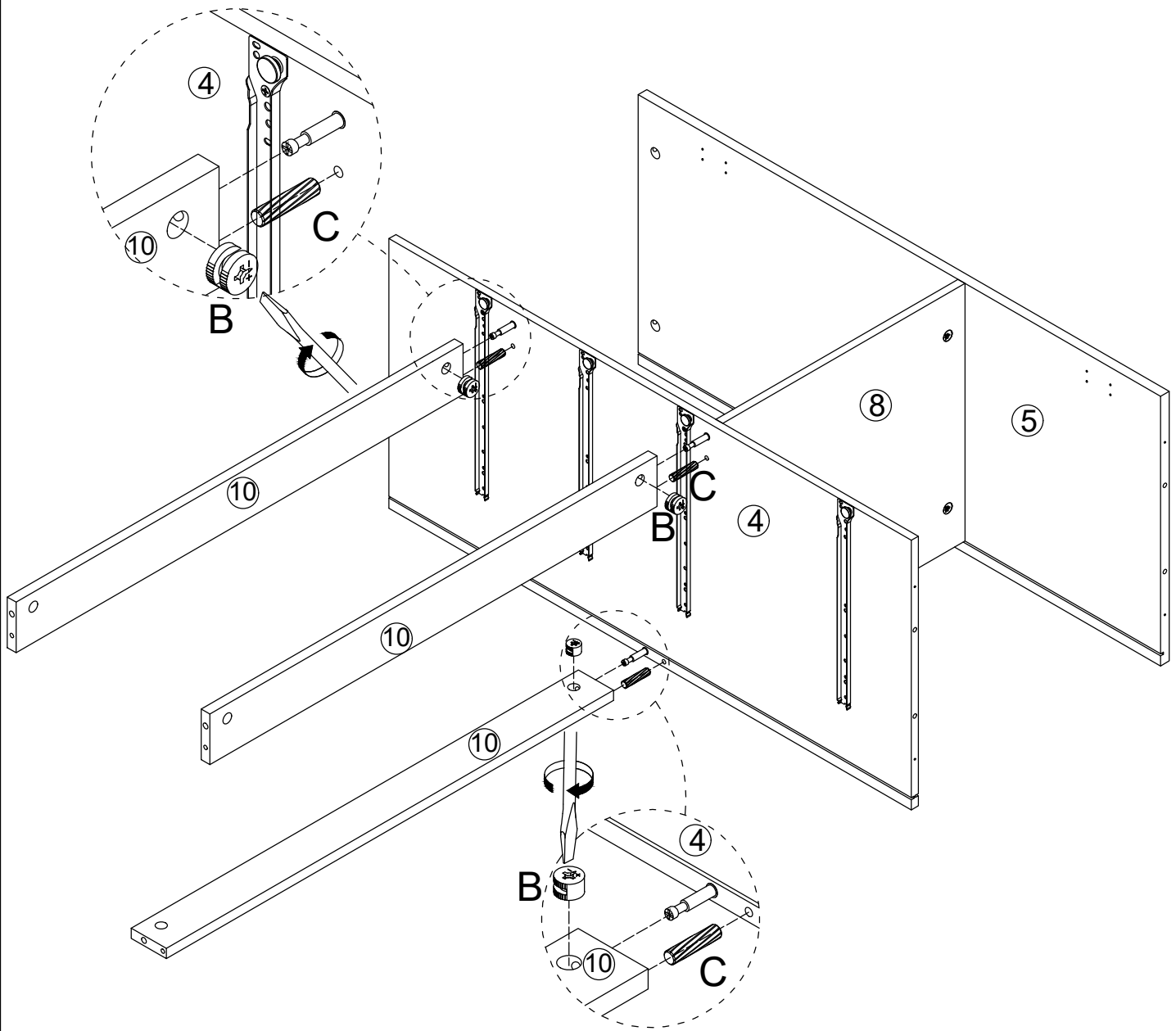



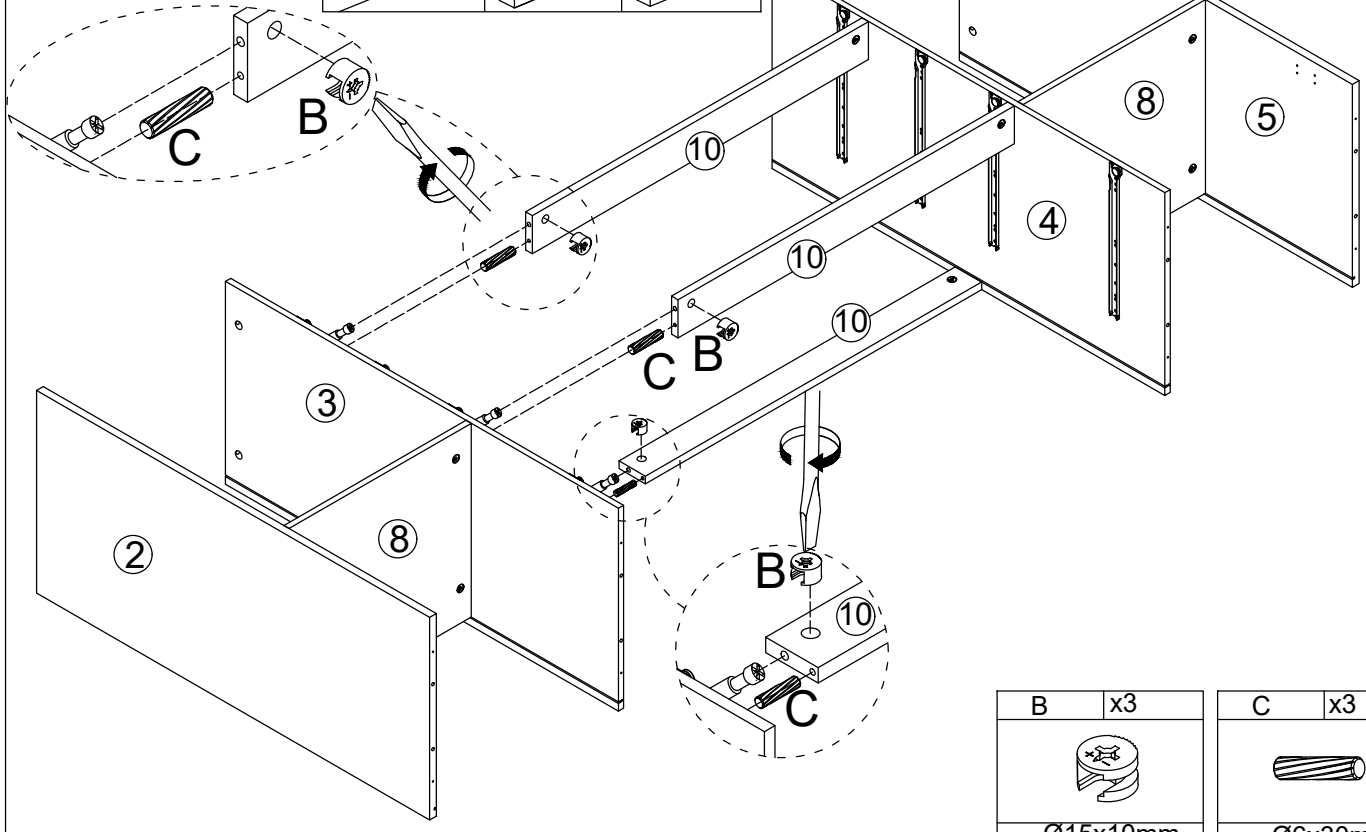
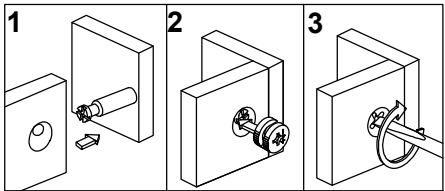

B	x3	C	x3
			
Ø15x10mm		Ø6x30mm	

11



B	x3	C	x3
			
Ø15x10mm		Ø6x30mm	

12

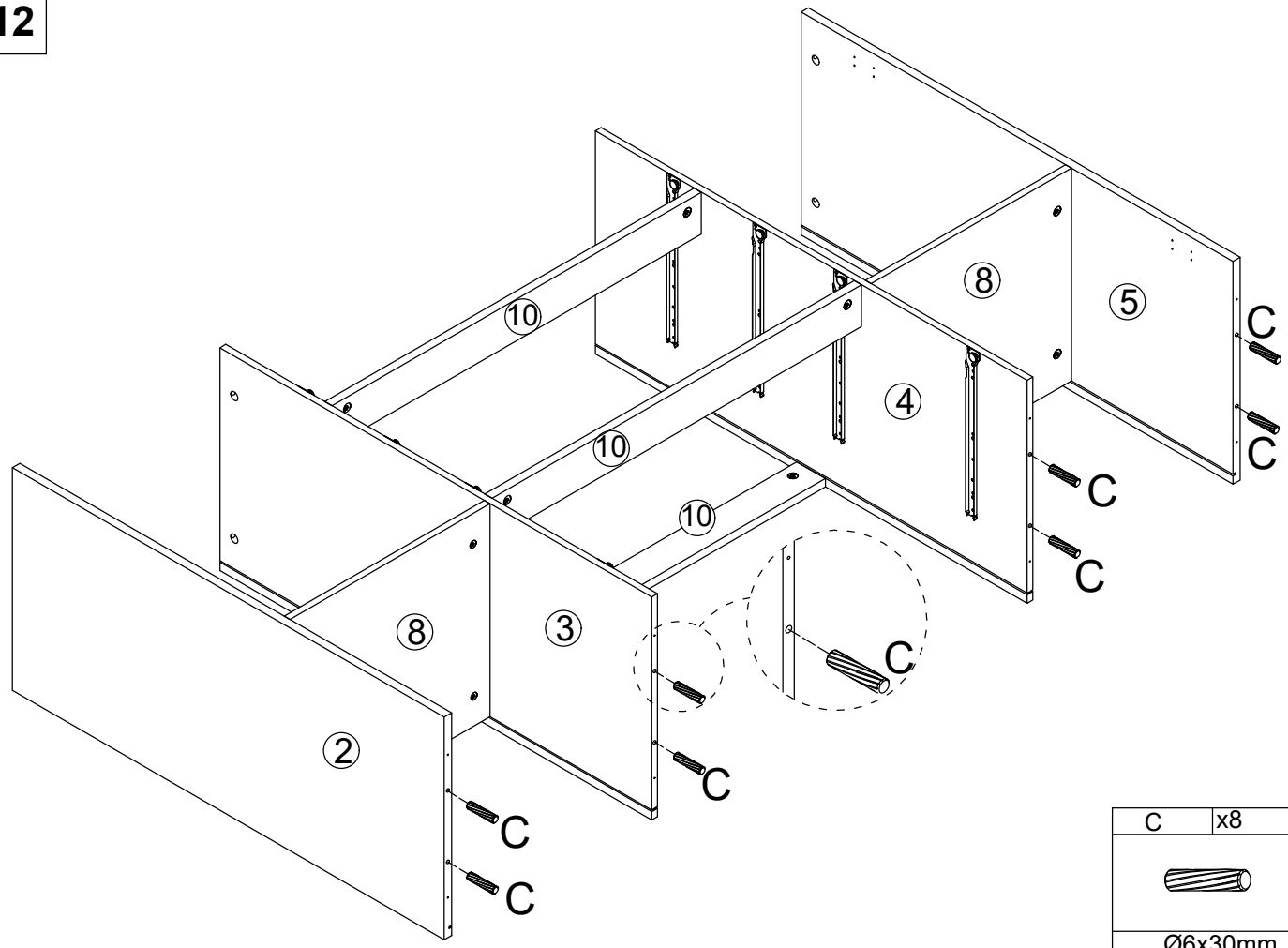

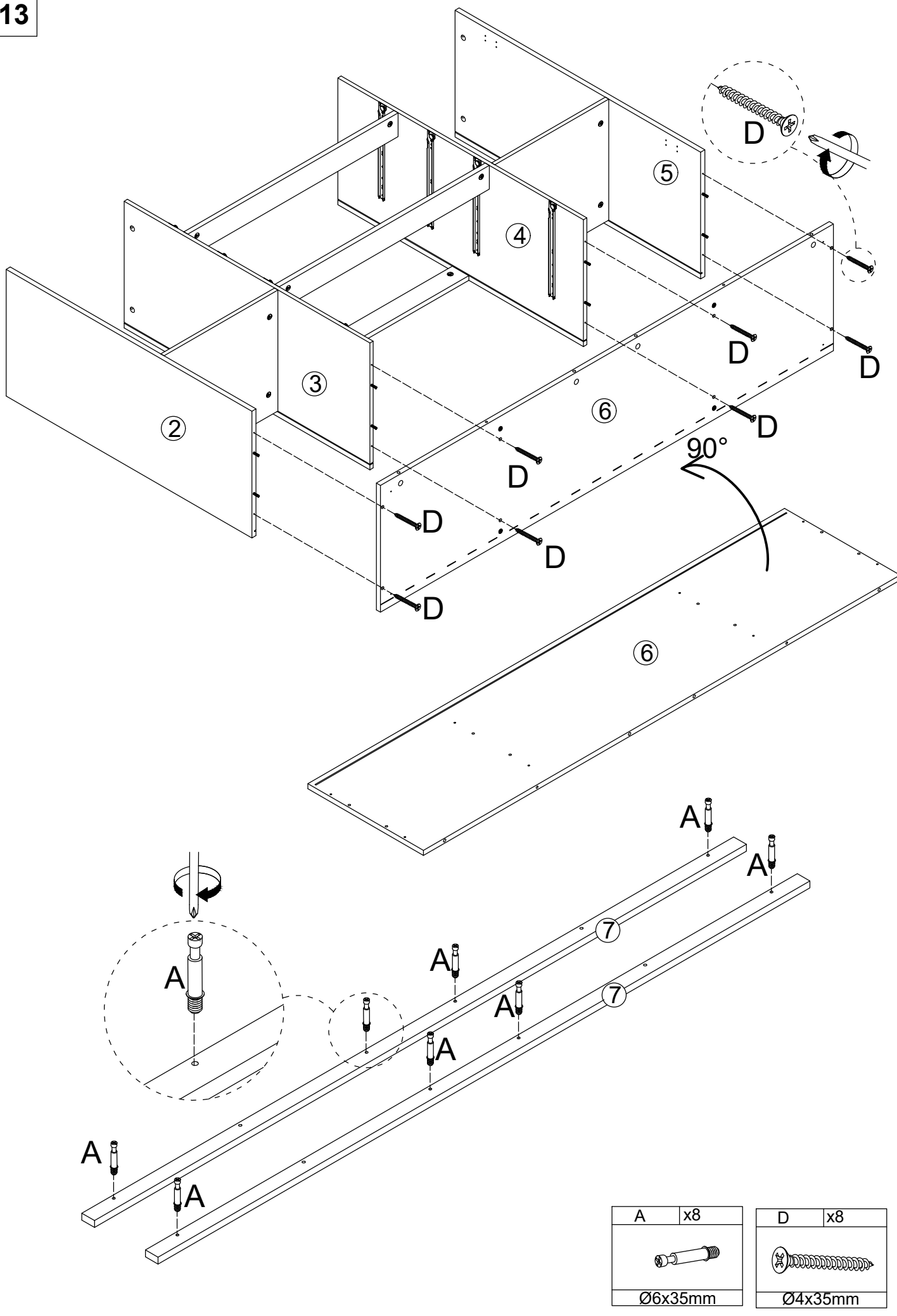

C	x8
	
Ø6x30mm	

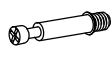

A	x8
	
Ø6x35mm	

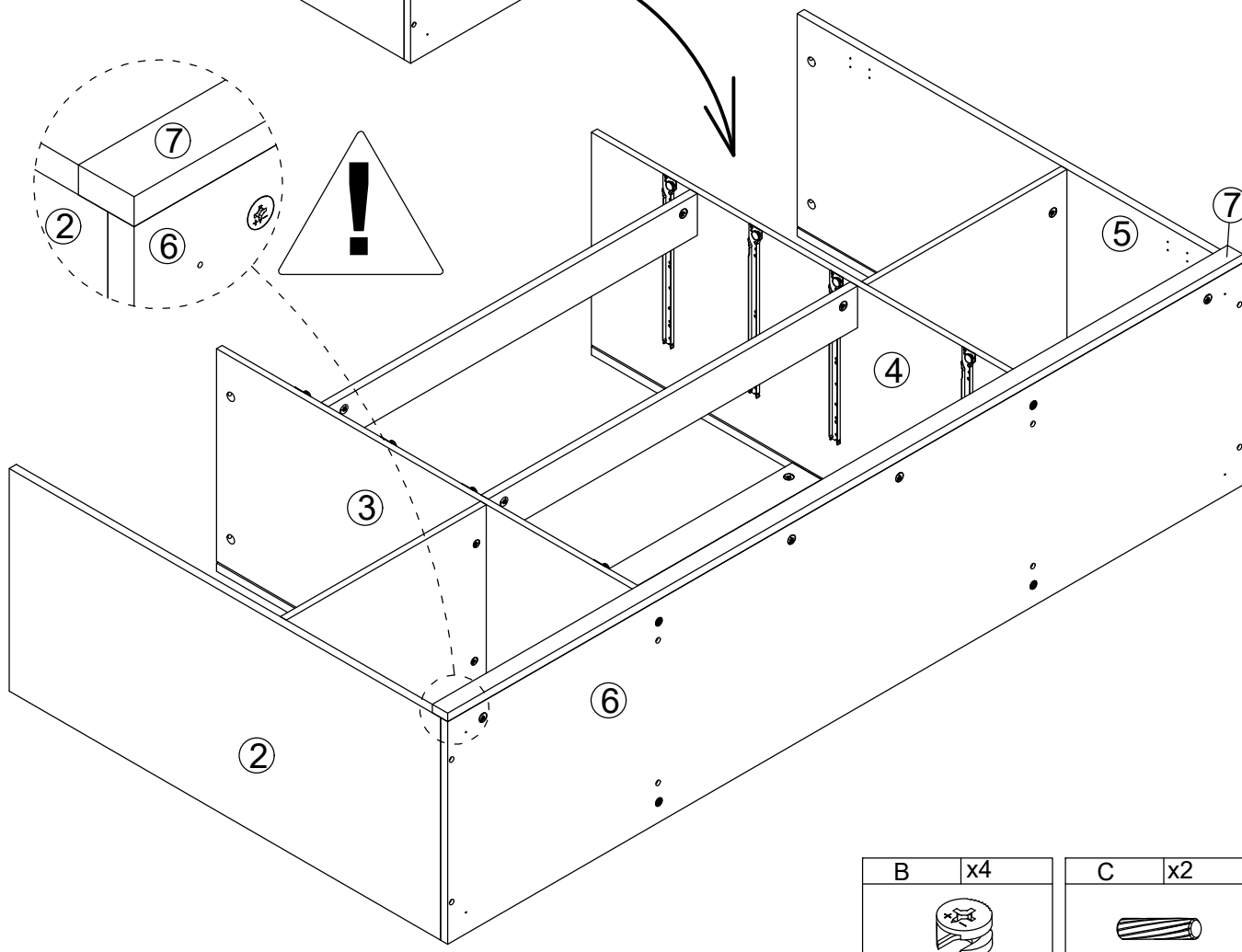
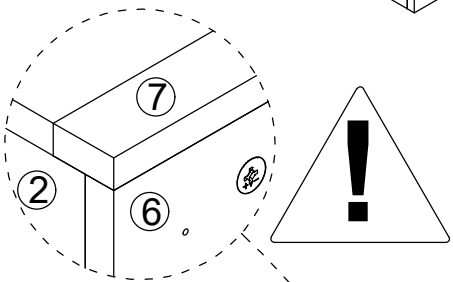
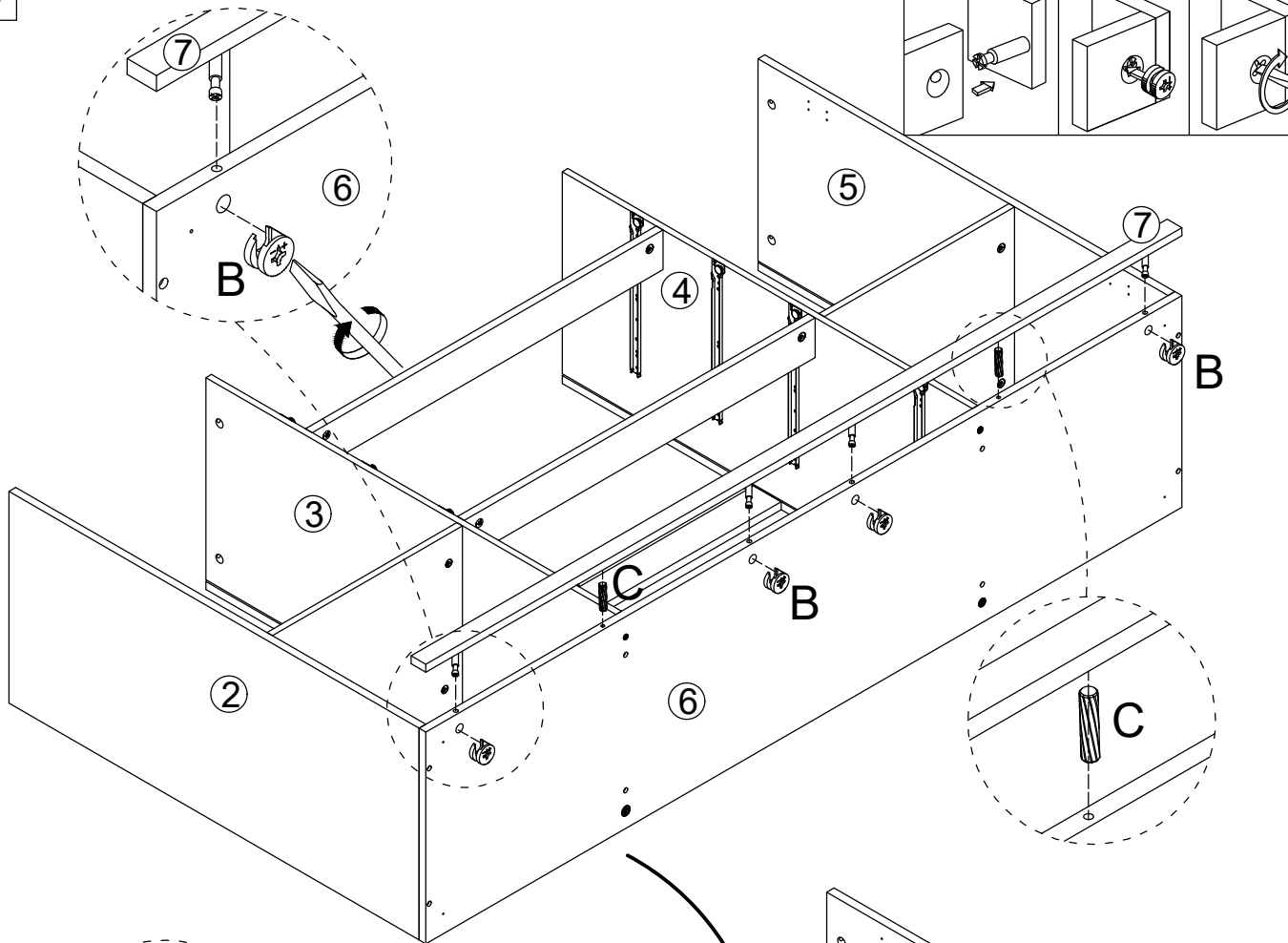
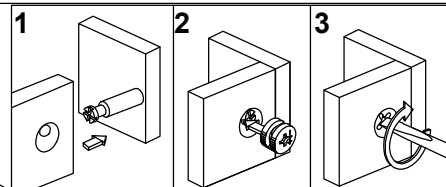
D	x8
	
Ø4x35mm	



B	x4	C	x2
			
Ø15x10mm		Ø6x30mm	

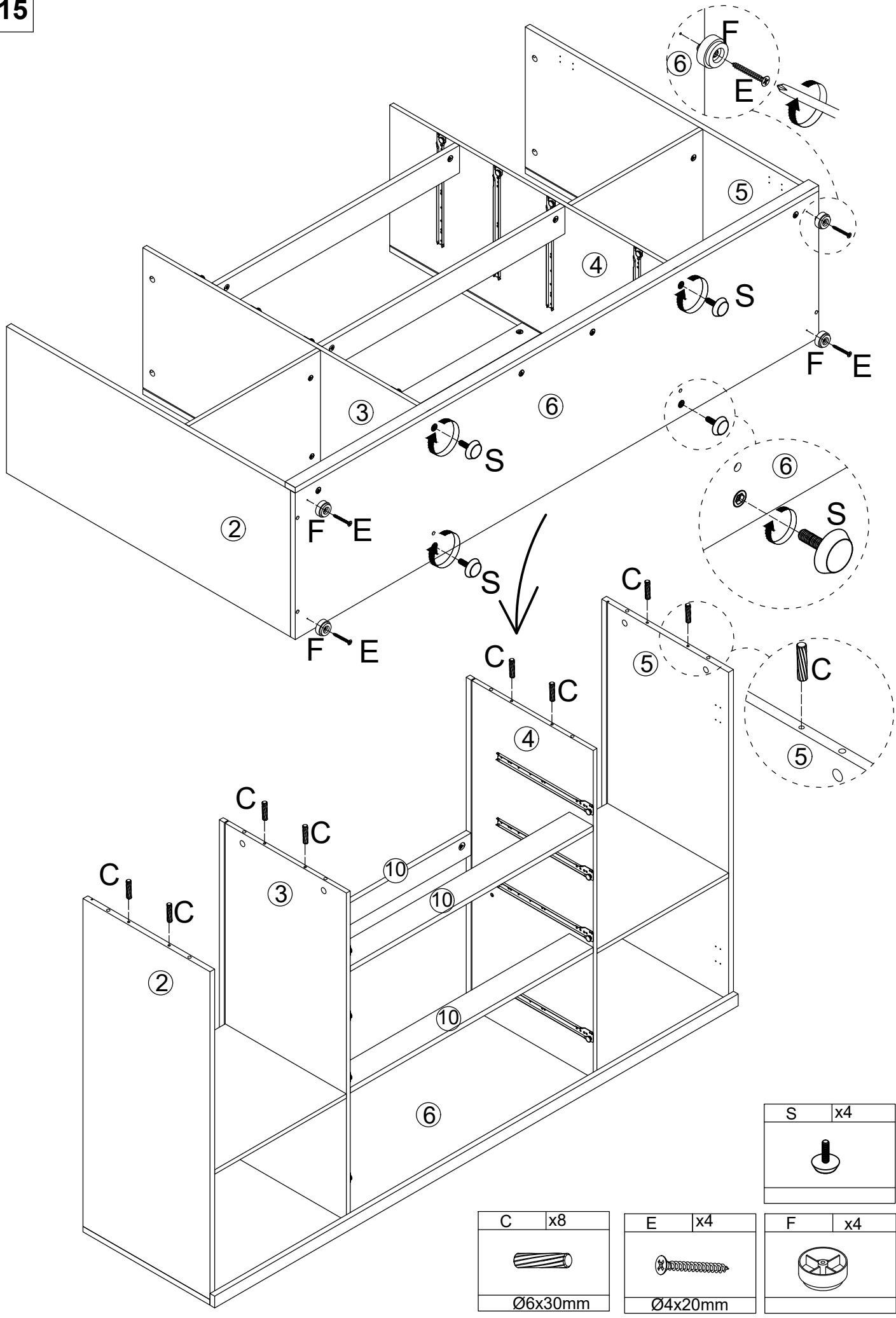

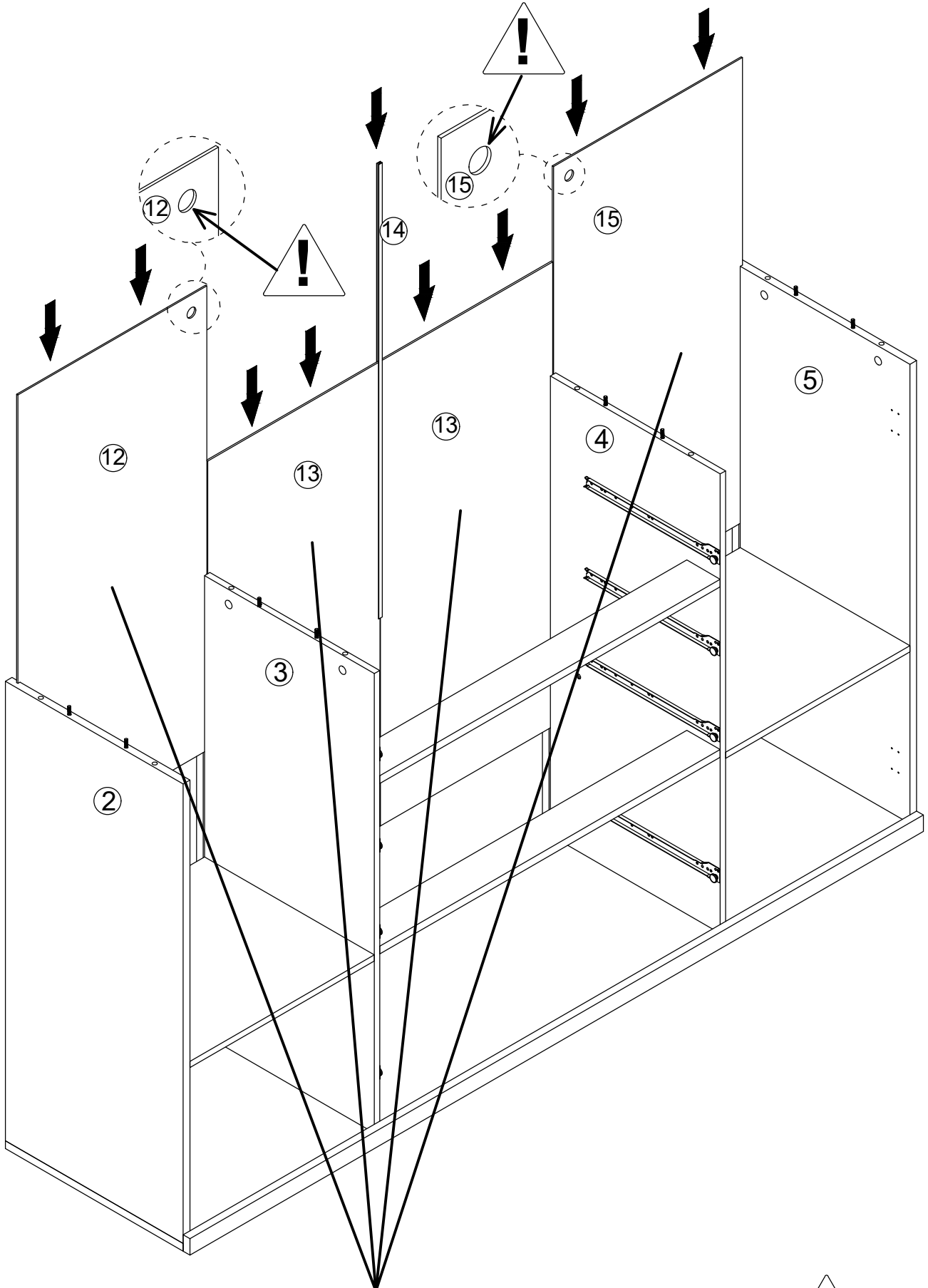



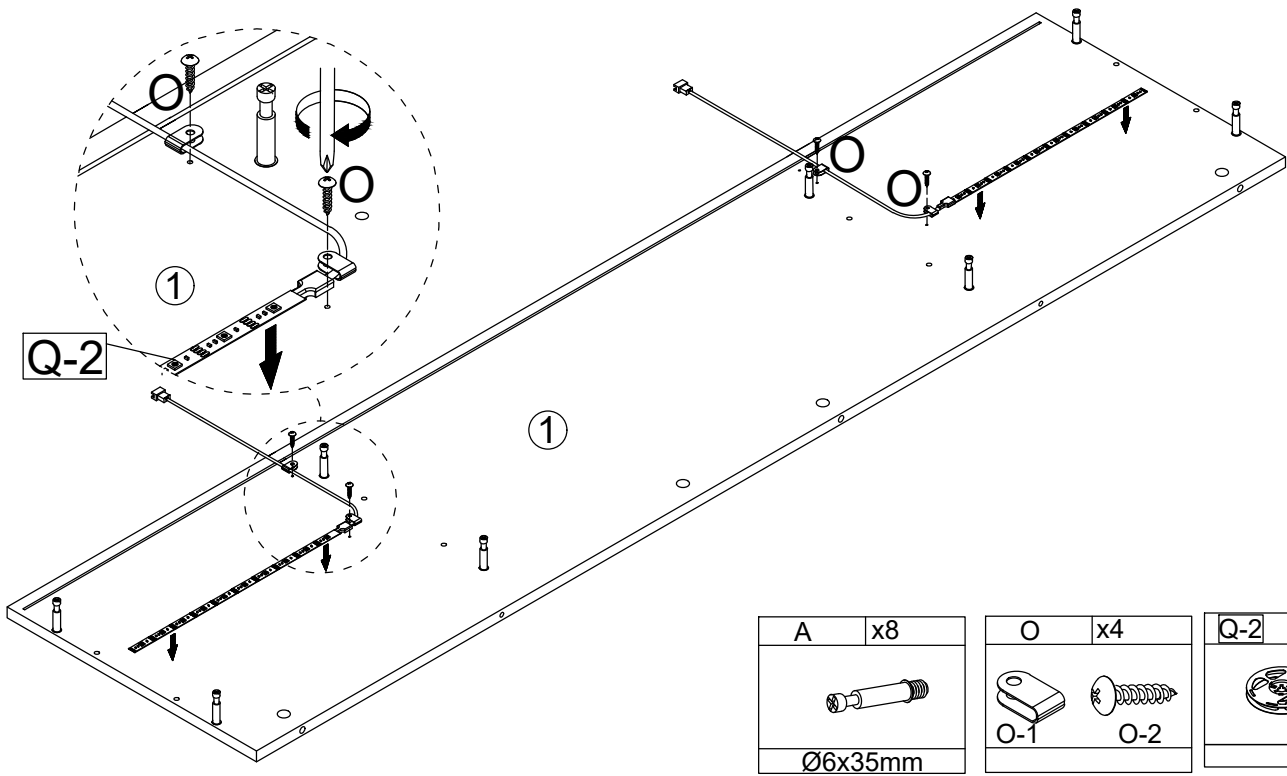
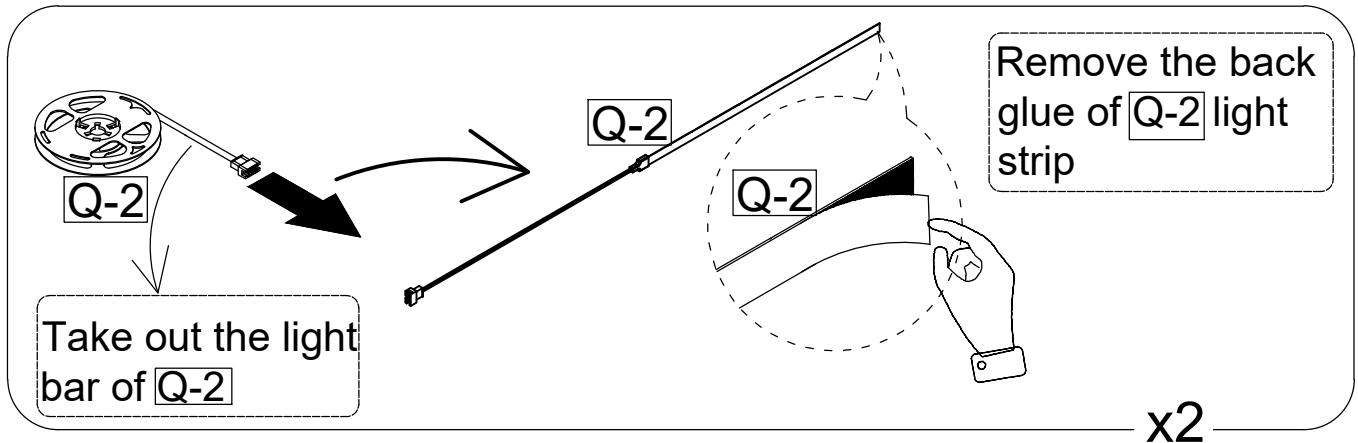
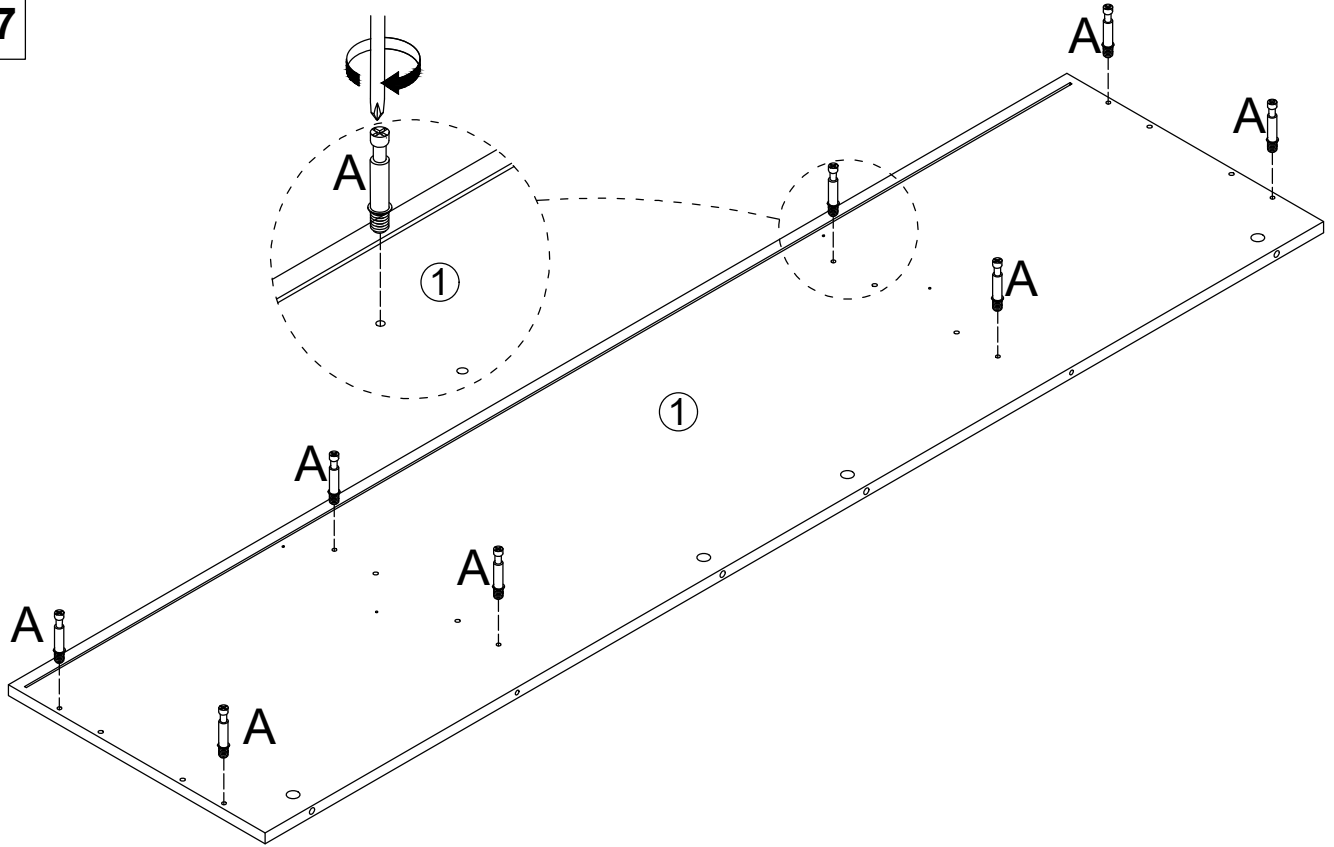

12、 13 # and 15 # backplates are black facing the front

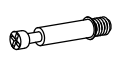





A	x8	O	x4	Q-2	x2
		 			
Ø6x35mm					

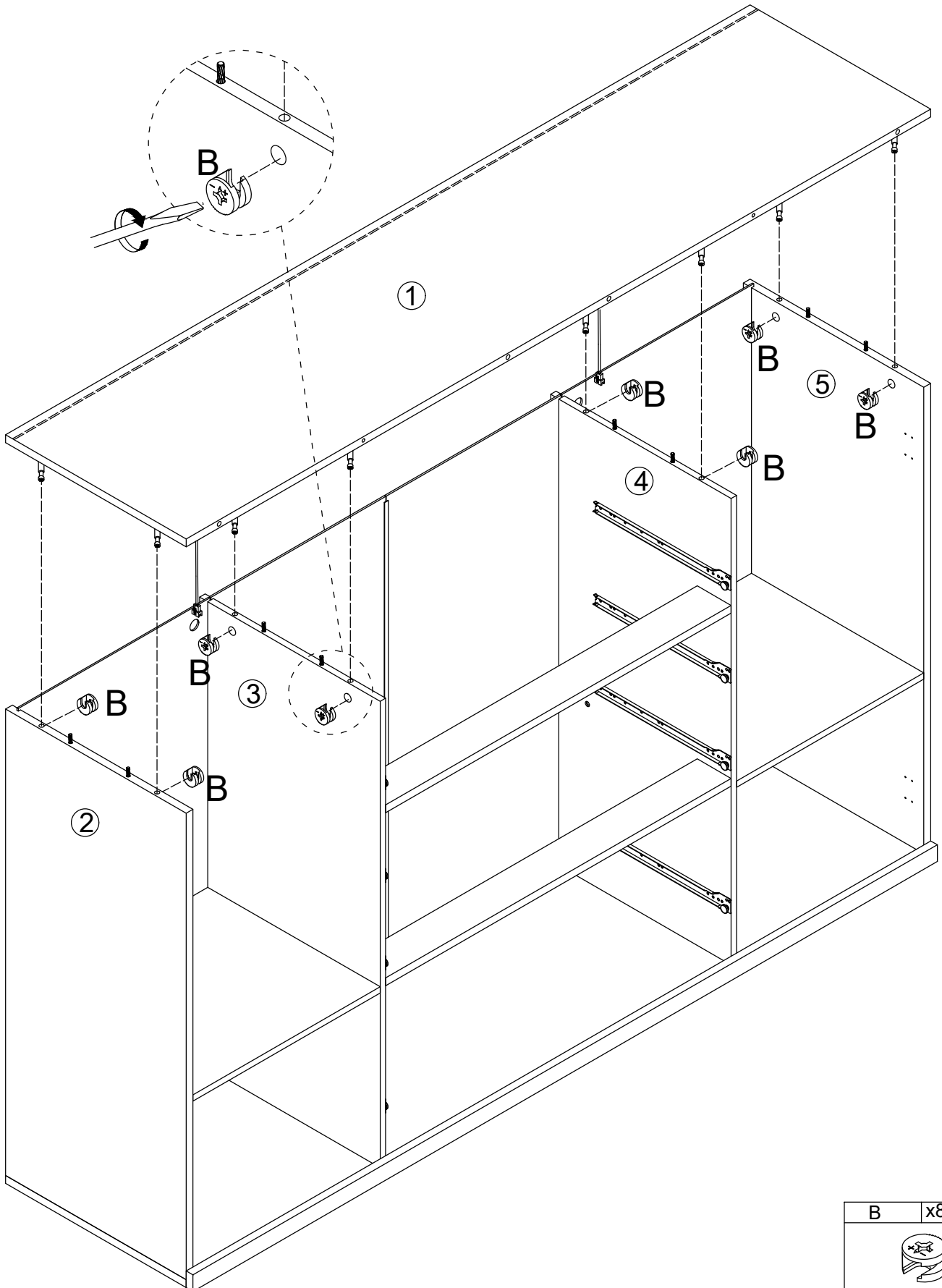
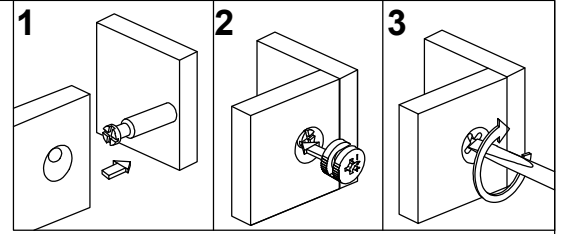



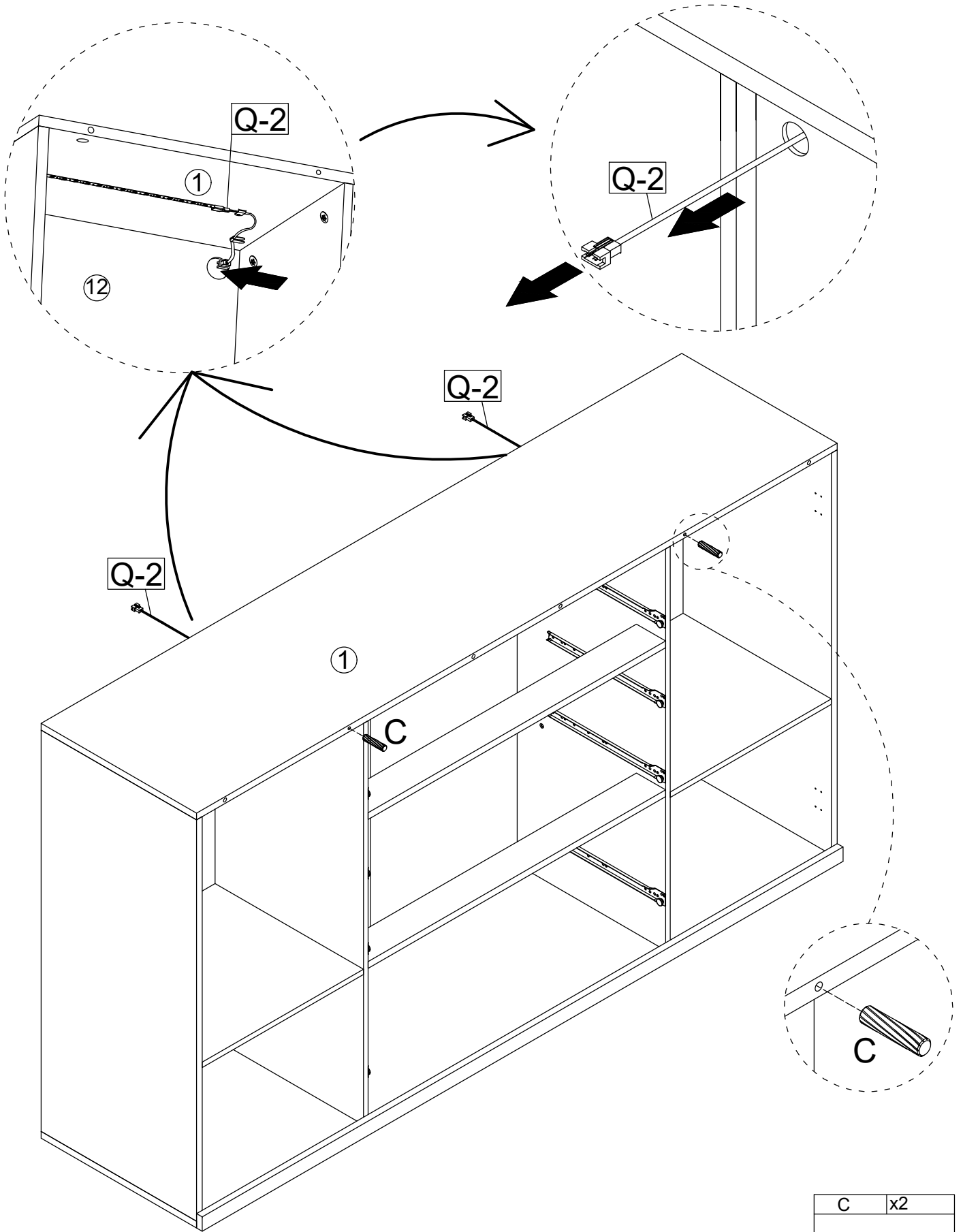

B	x8
Ø15x10mm	



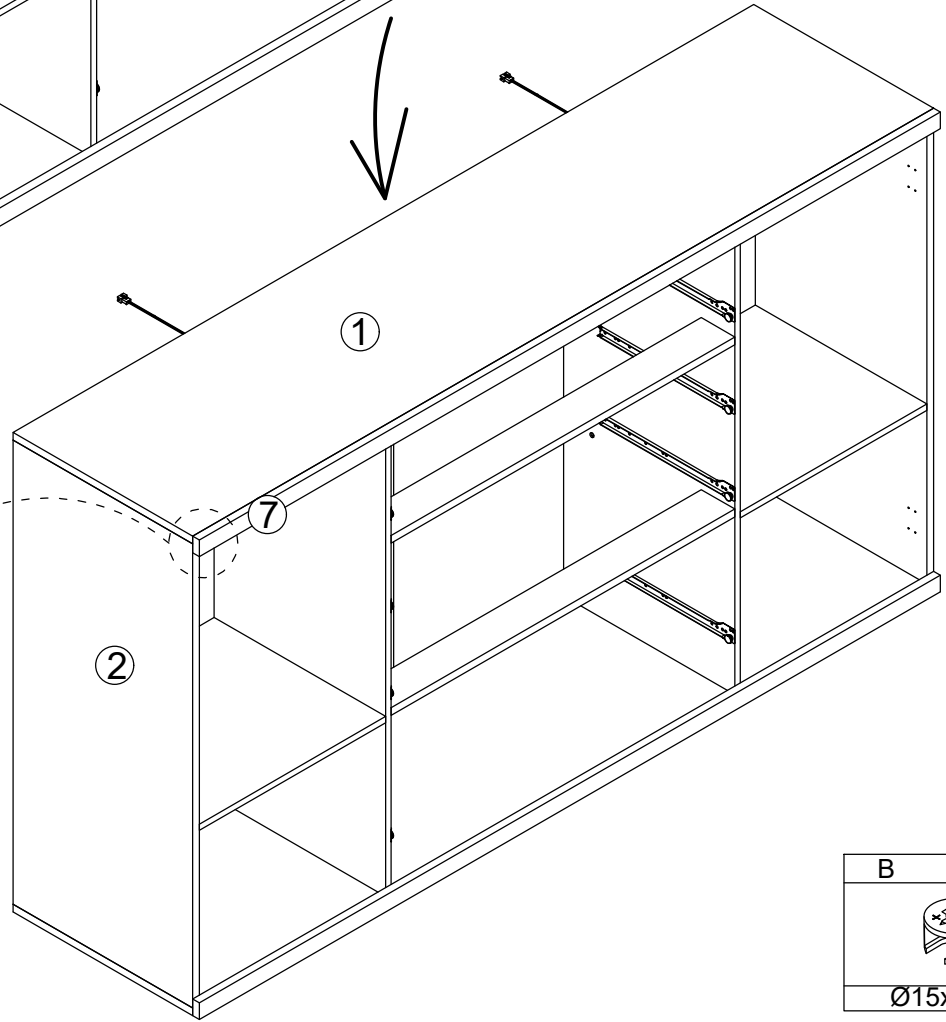
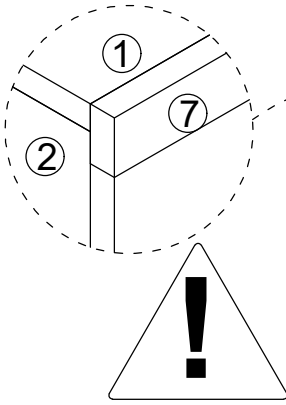
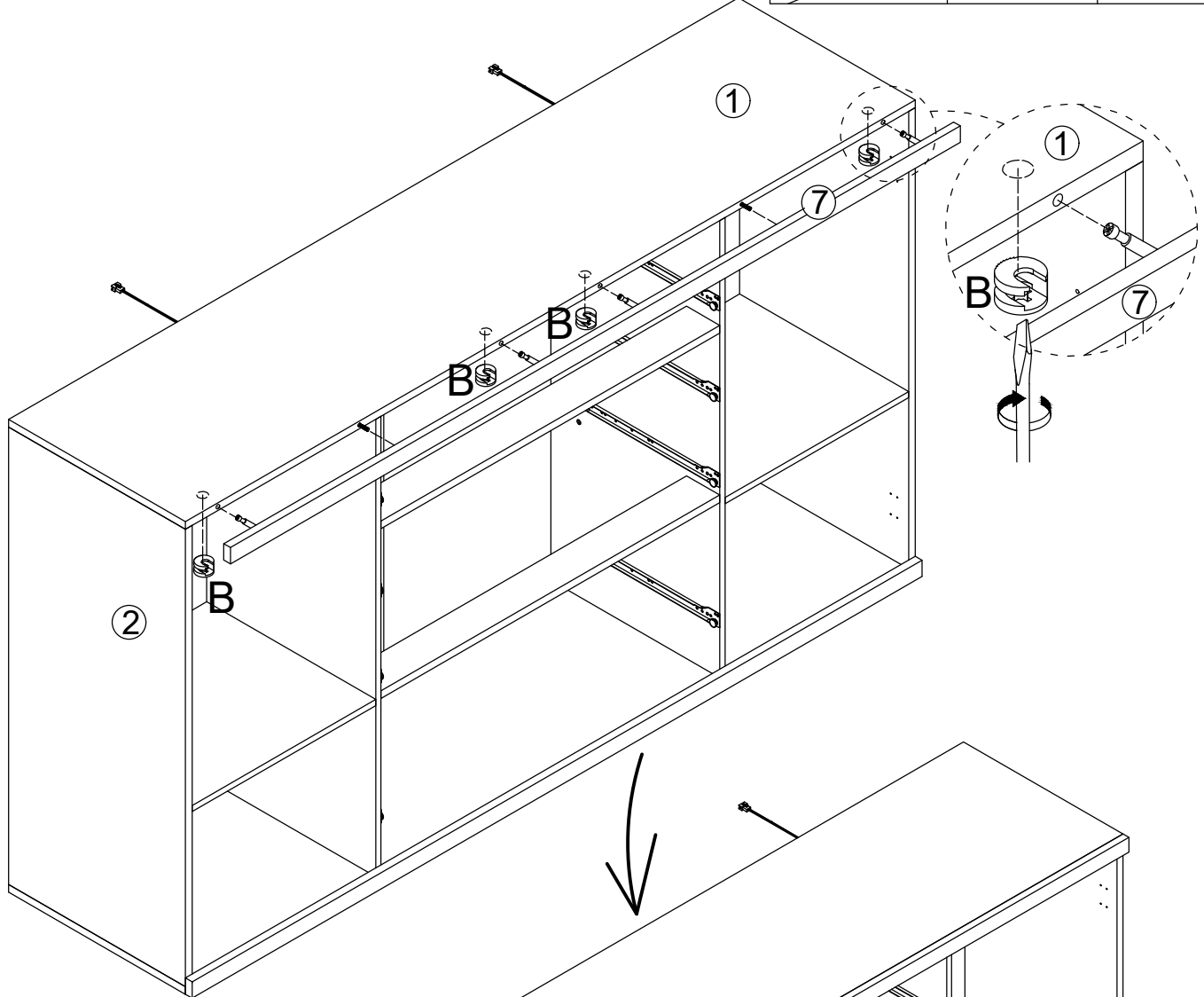
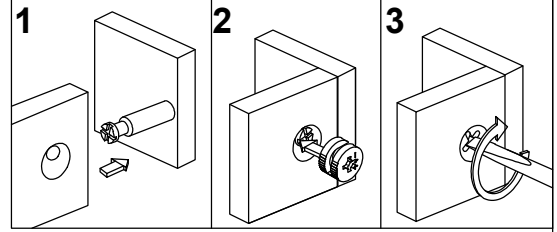



C	x2
	
Ø6x30mm	

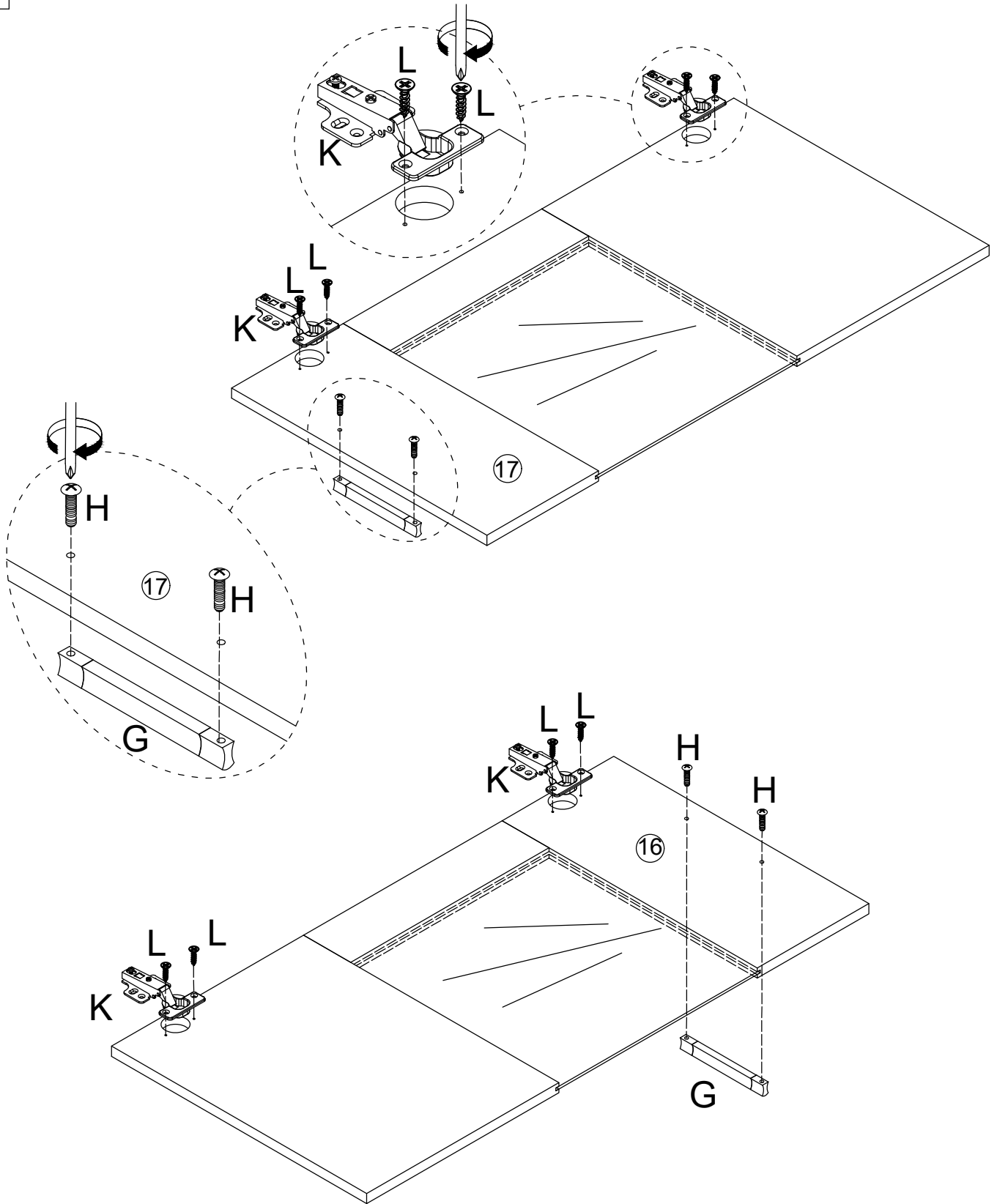

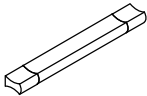
B	x4
	
Ø15x10mm	

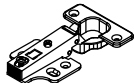



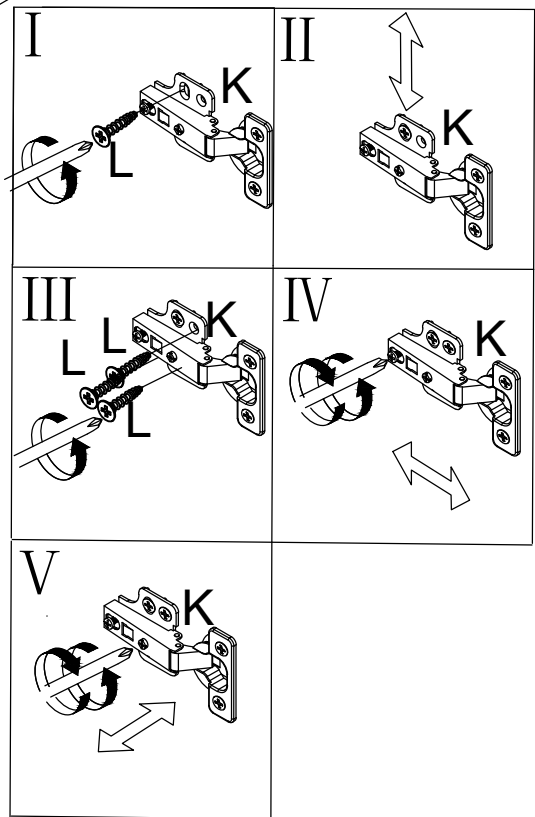
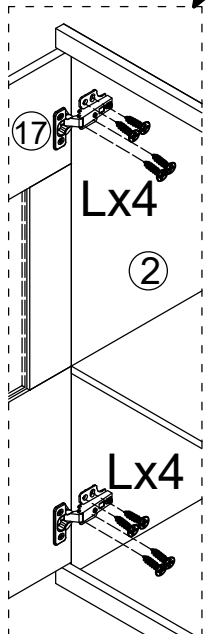
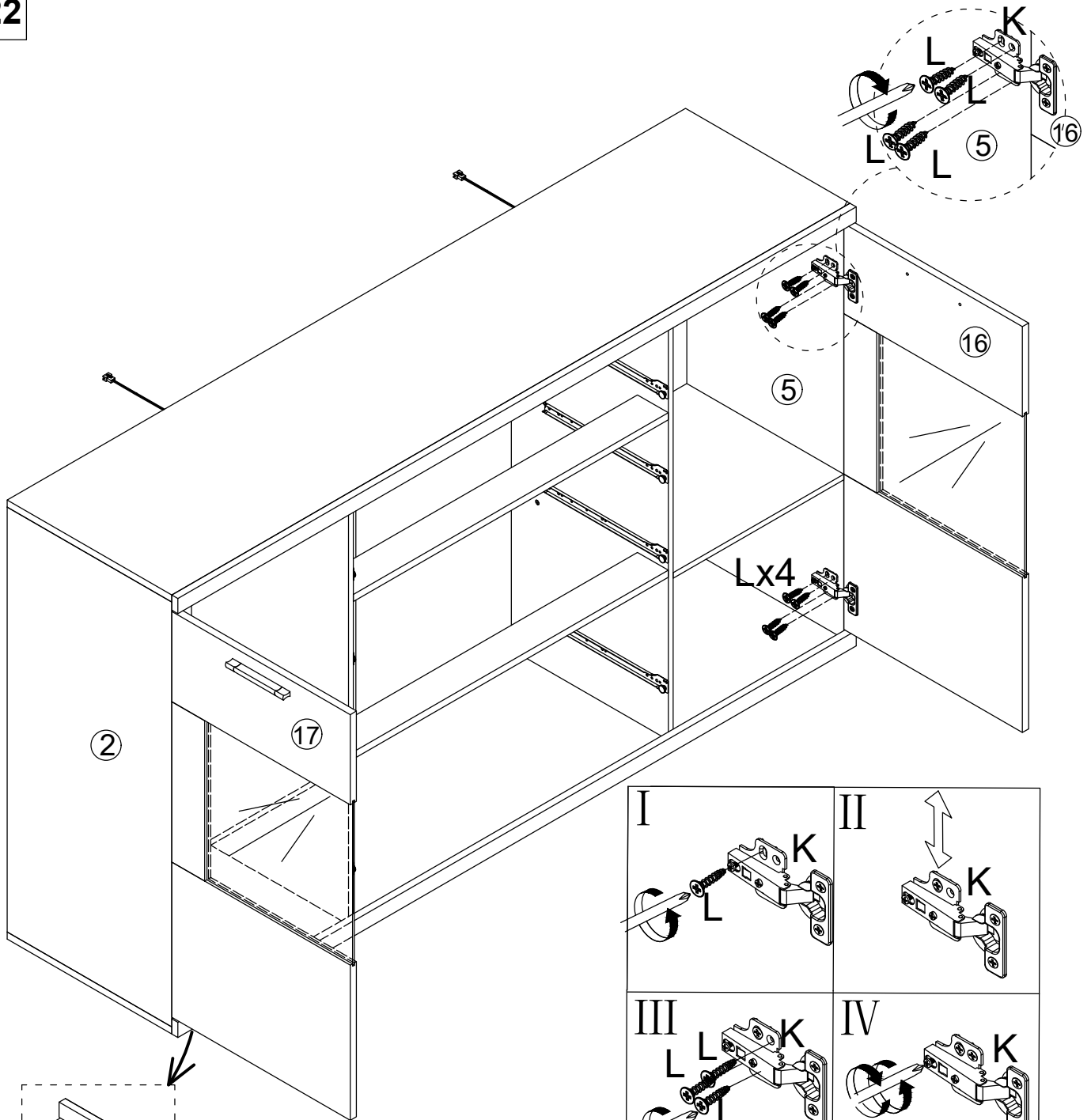

G	x2	H	x4	K	x4	L	x8
							

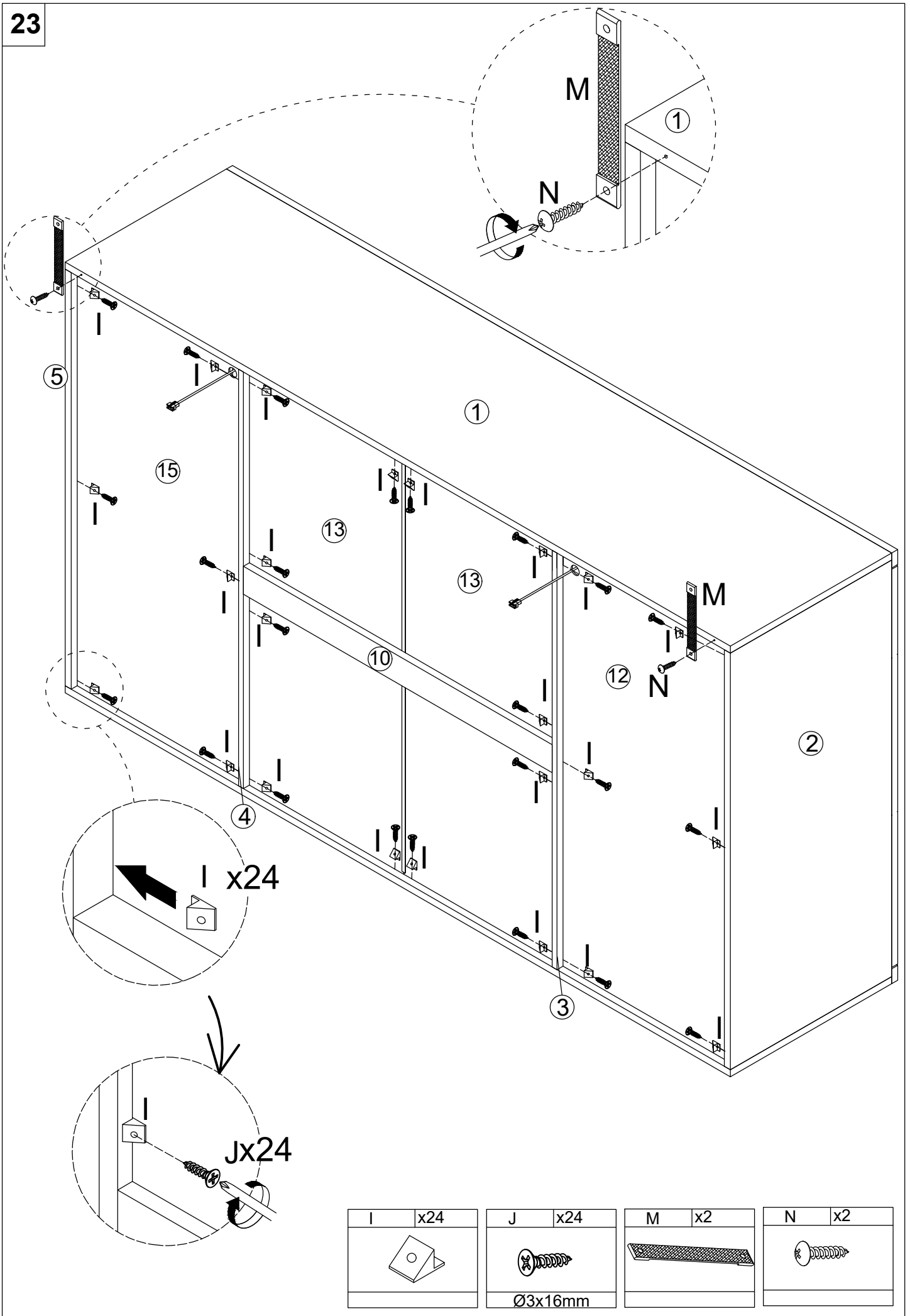

L	x16
	



I	x24	J	x24	M	x2	N	x2
							
		Ø3x16mm					

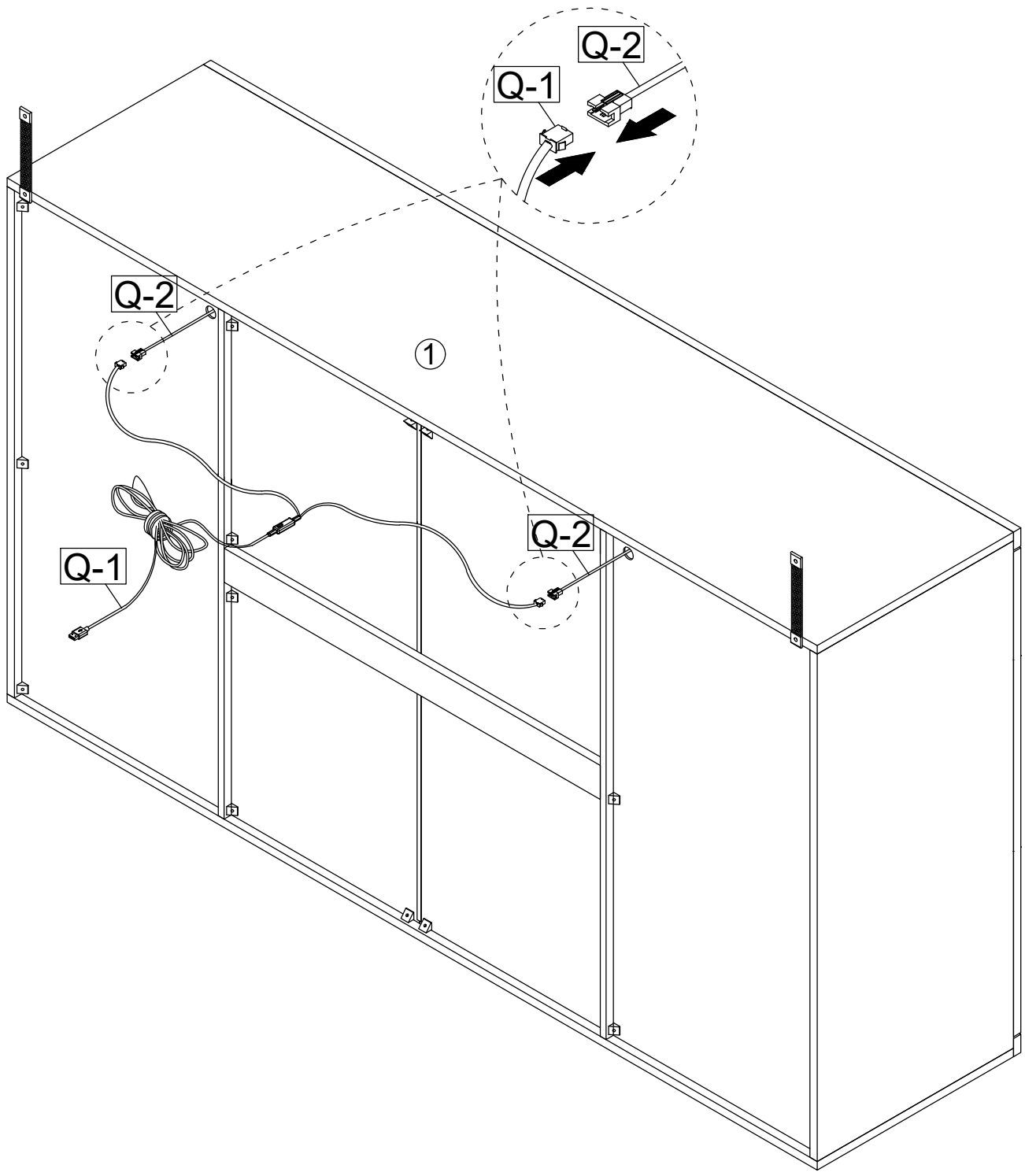

Q-1	x1

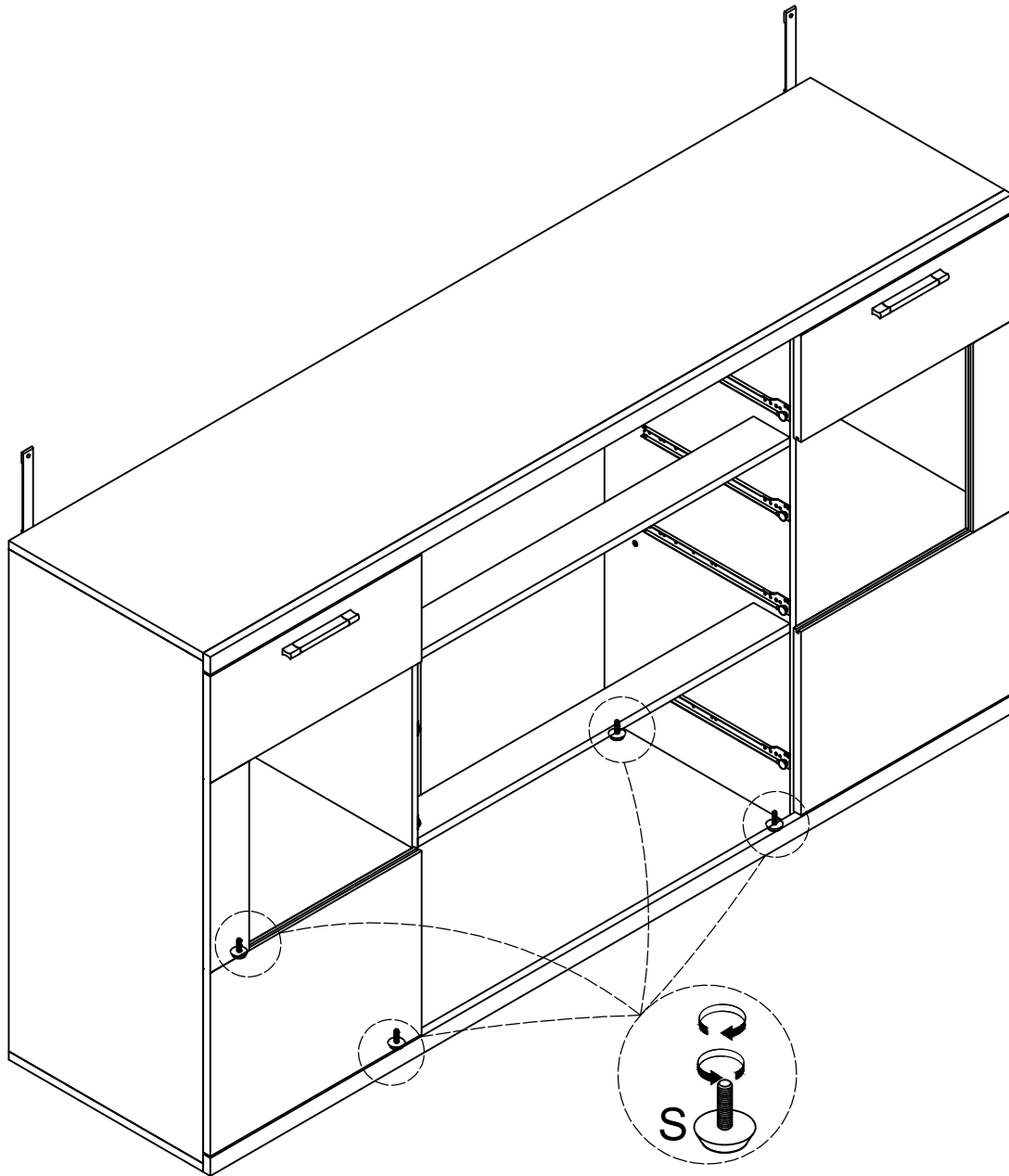

If the cabinet is not level with the ground,  
please adjust the bottom of the cabinet (S)

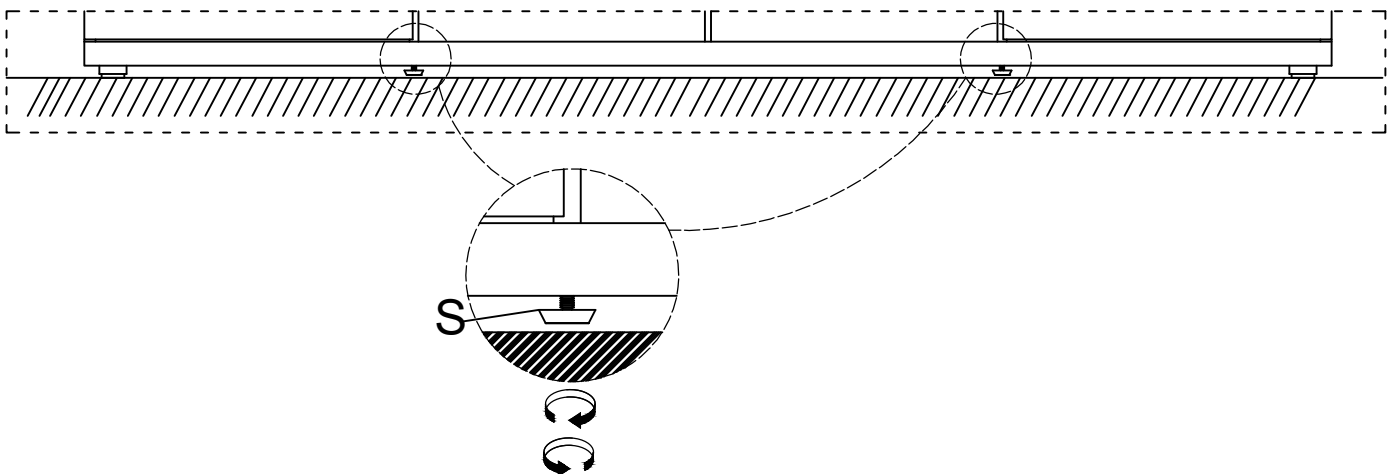



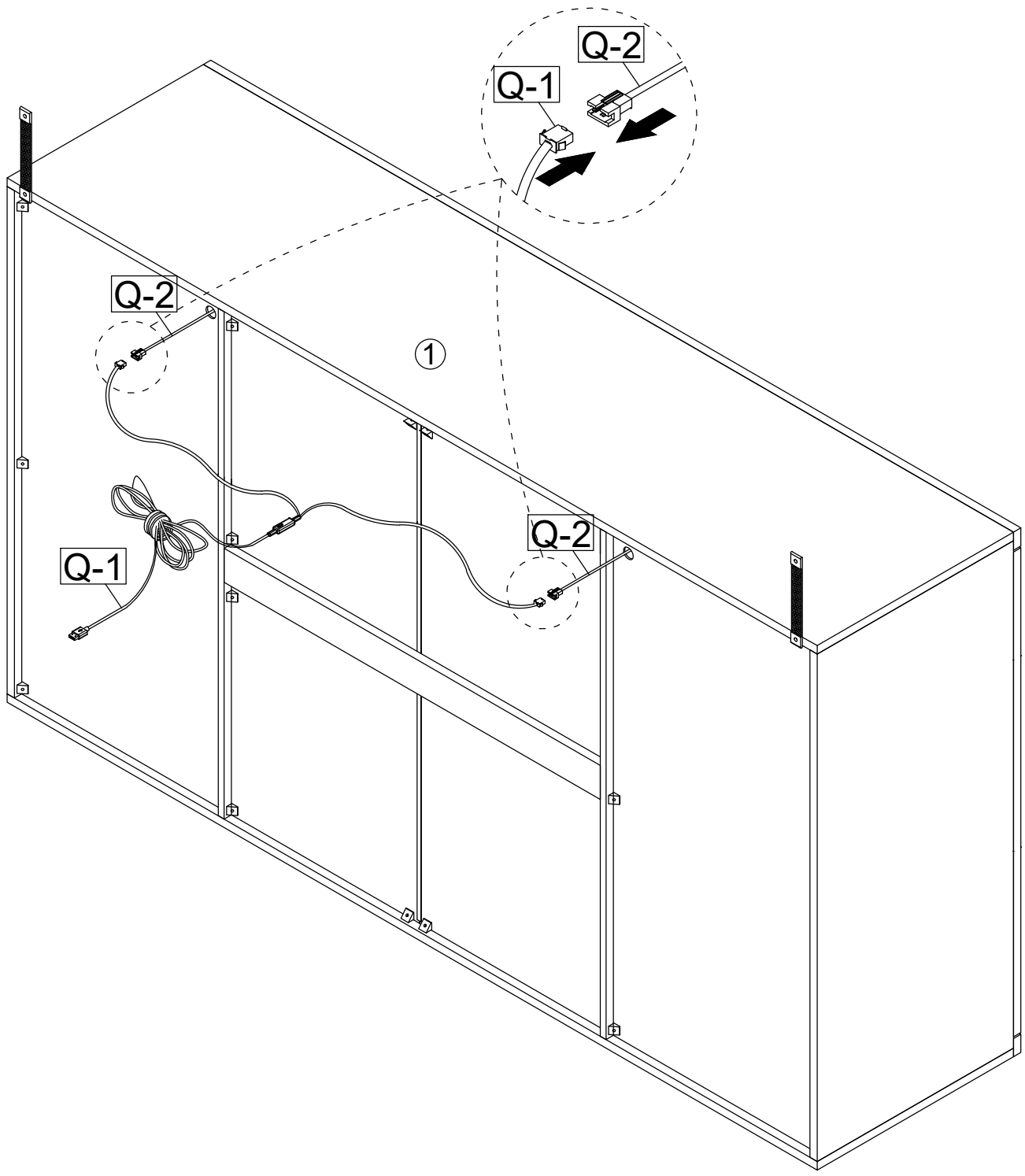

Q-1	x1

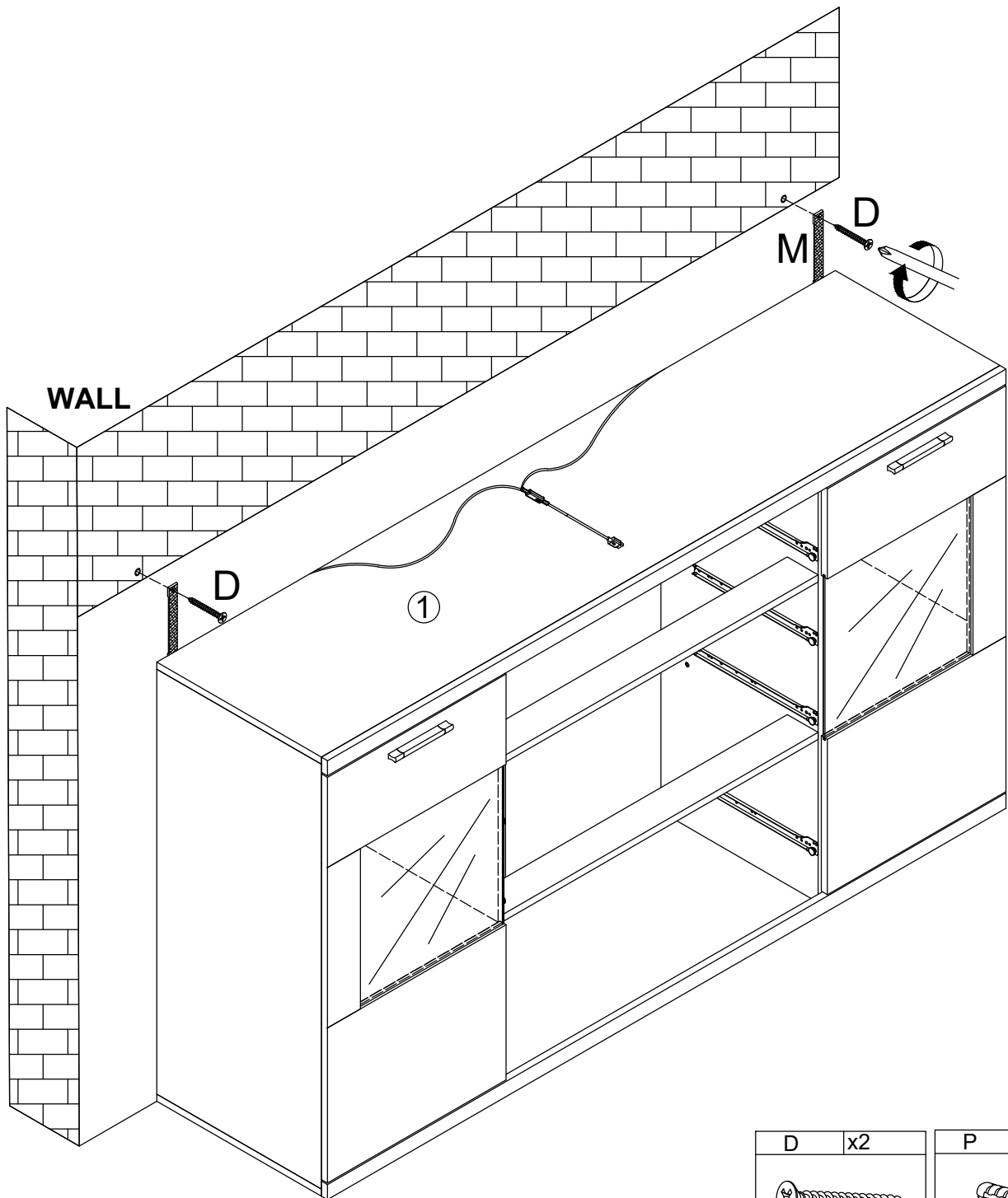
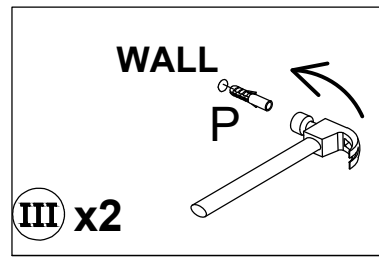
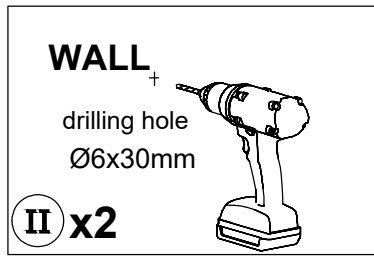
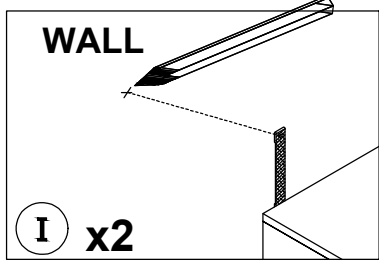

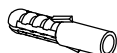
D	x2	P	x2
			
Ø4x35mm		Ø6x30mm	

27

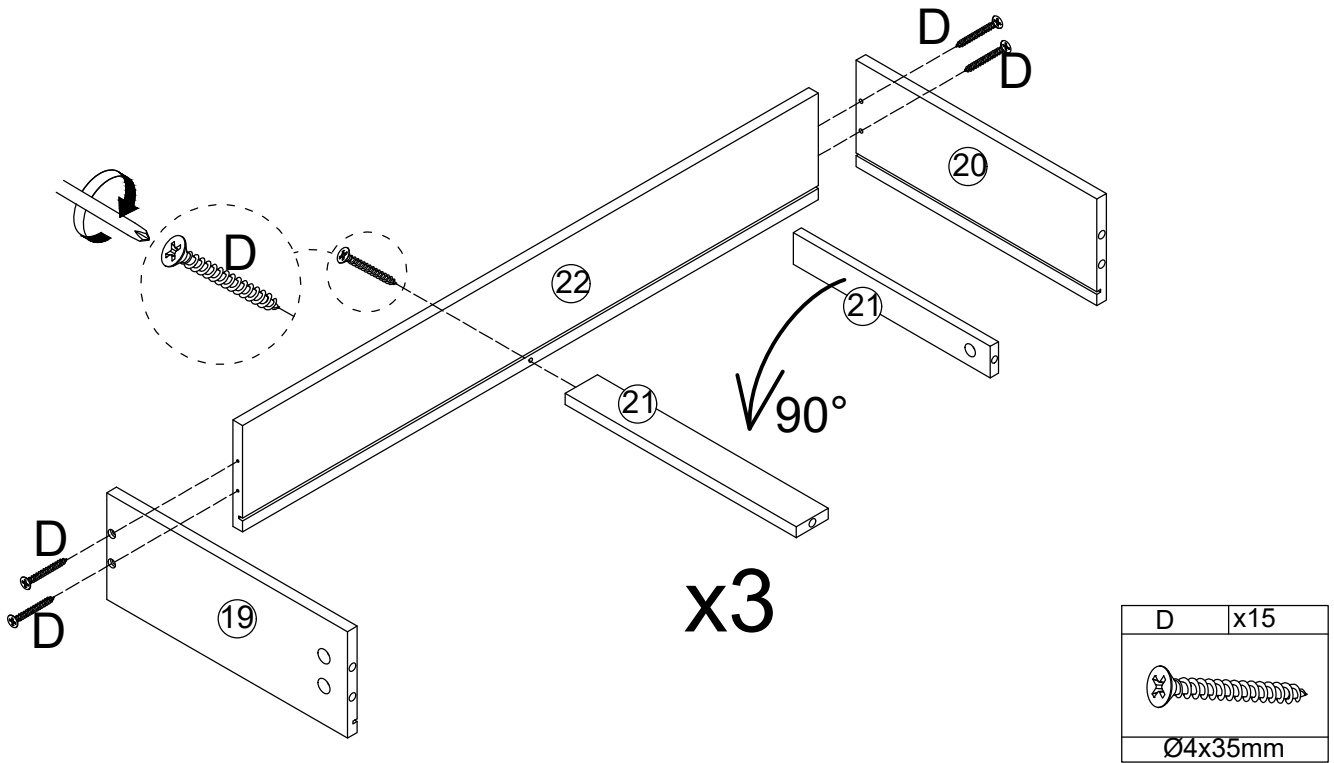

28

No wood grain is pasted on the 23 # pumping base plate, which faces the 21 # side

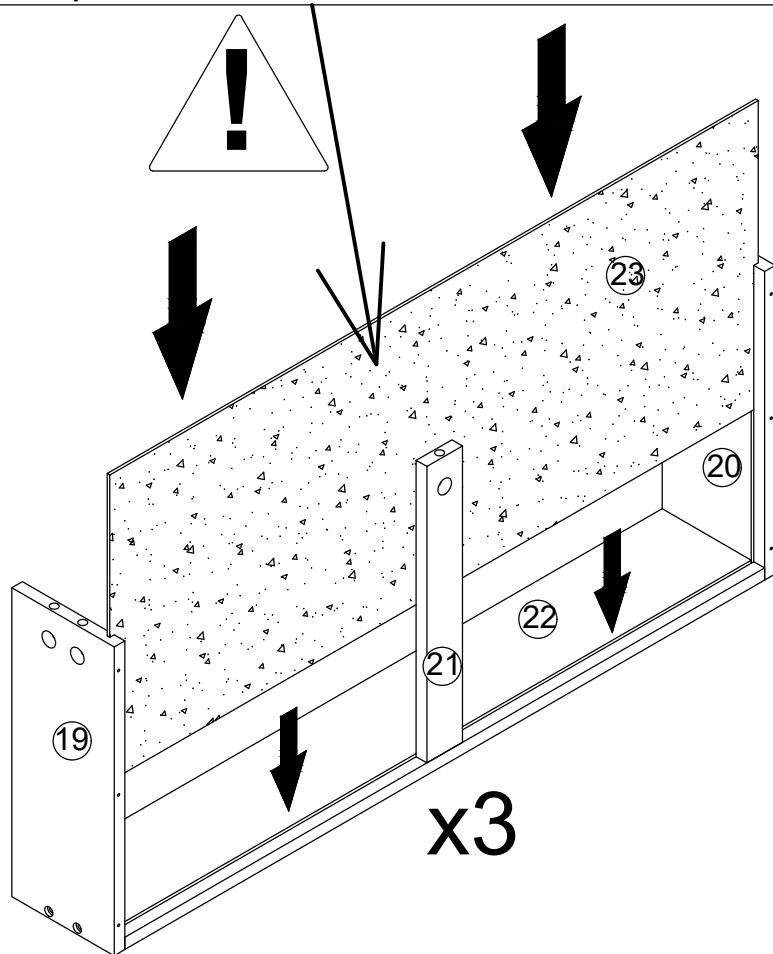

29

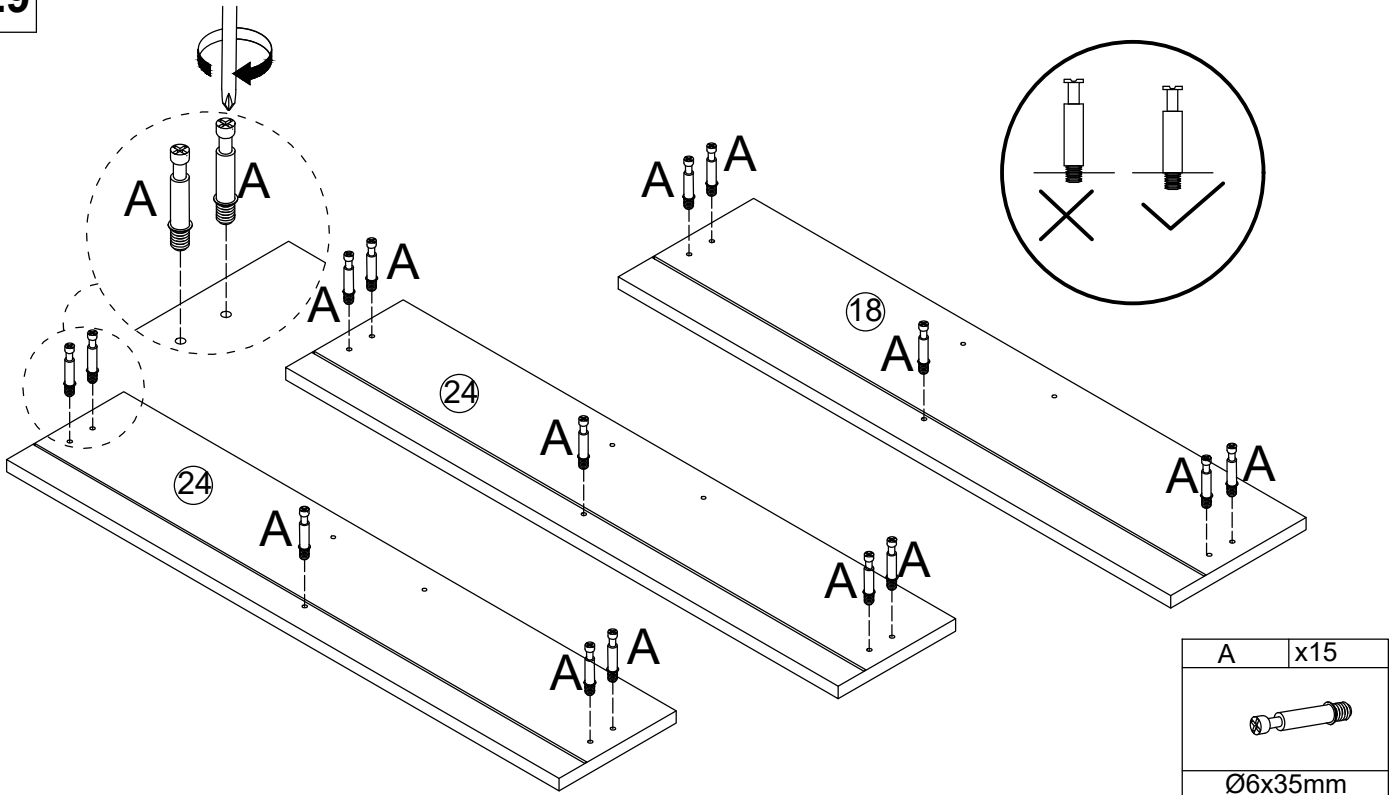

30

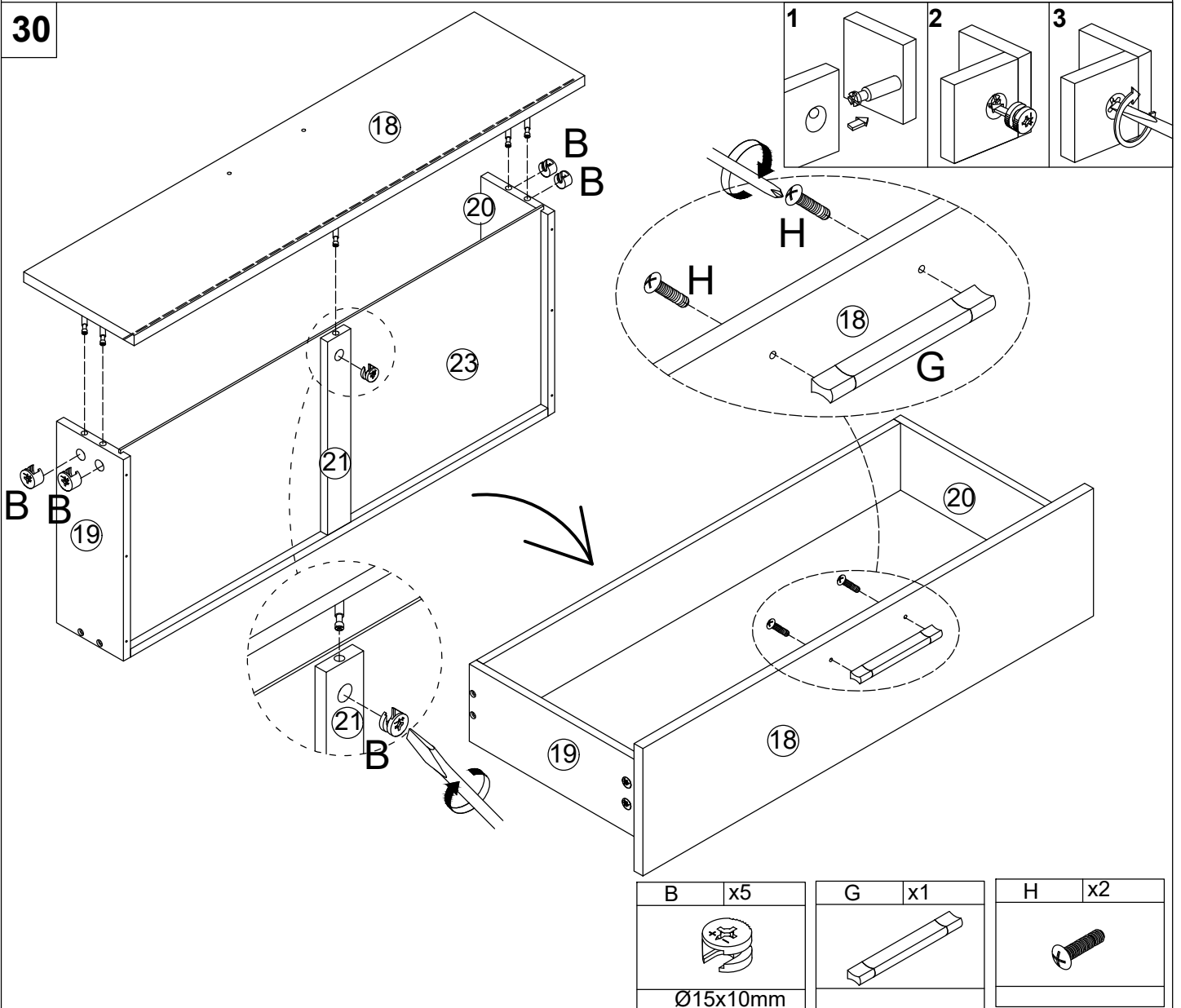

31

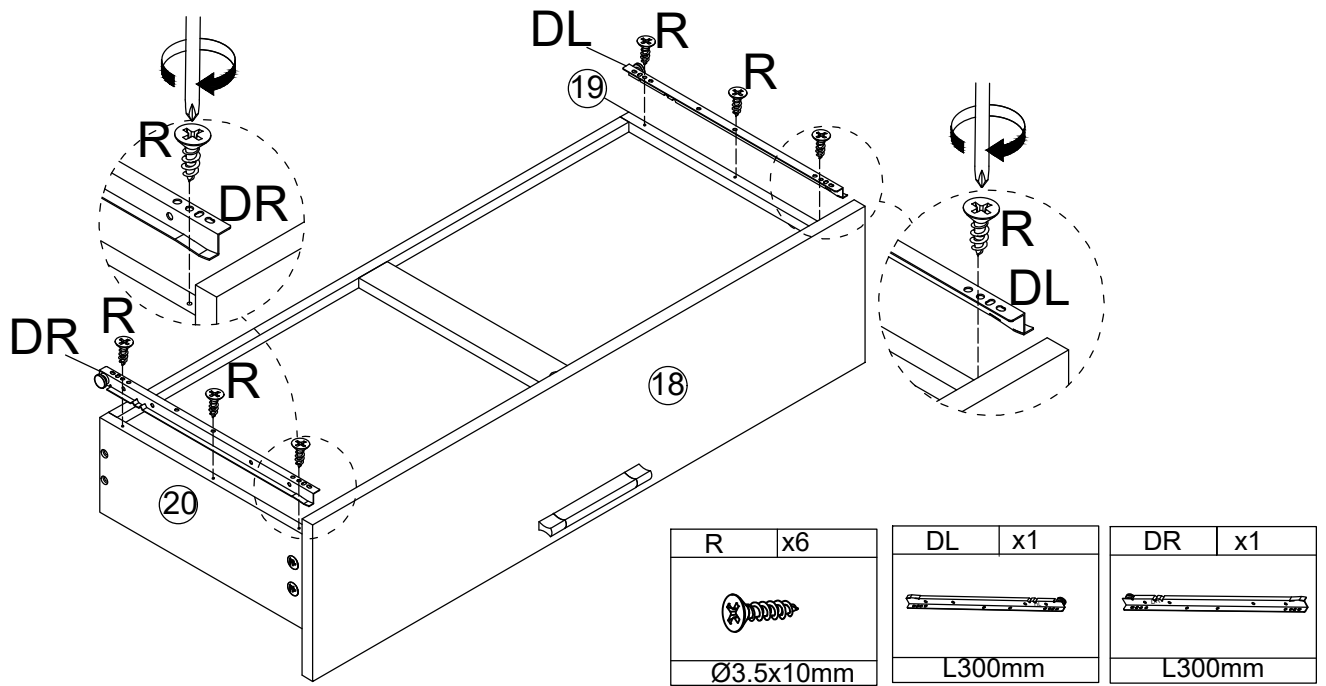

32

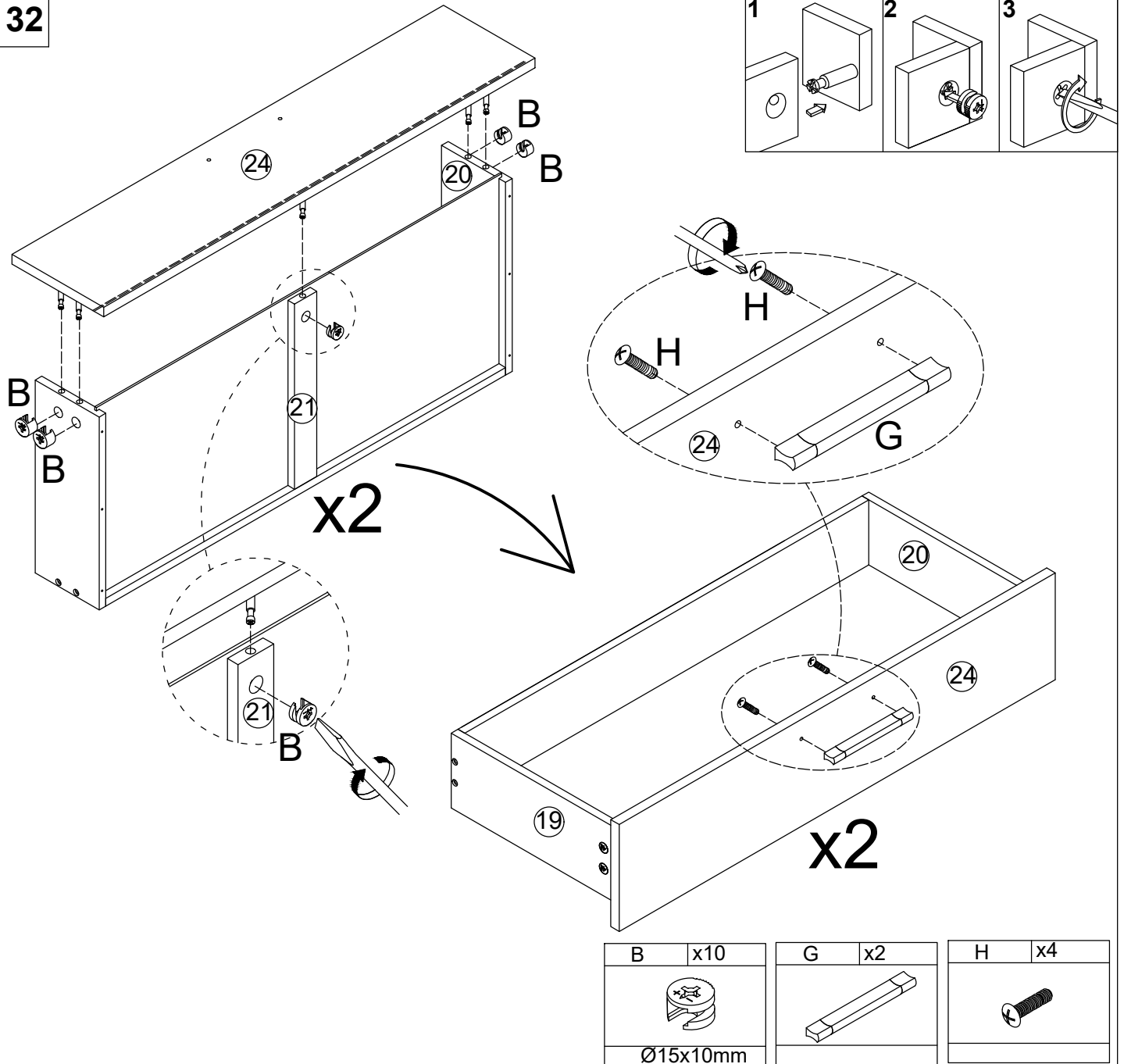



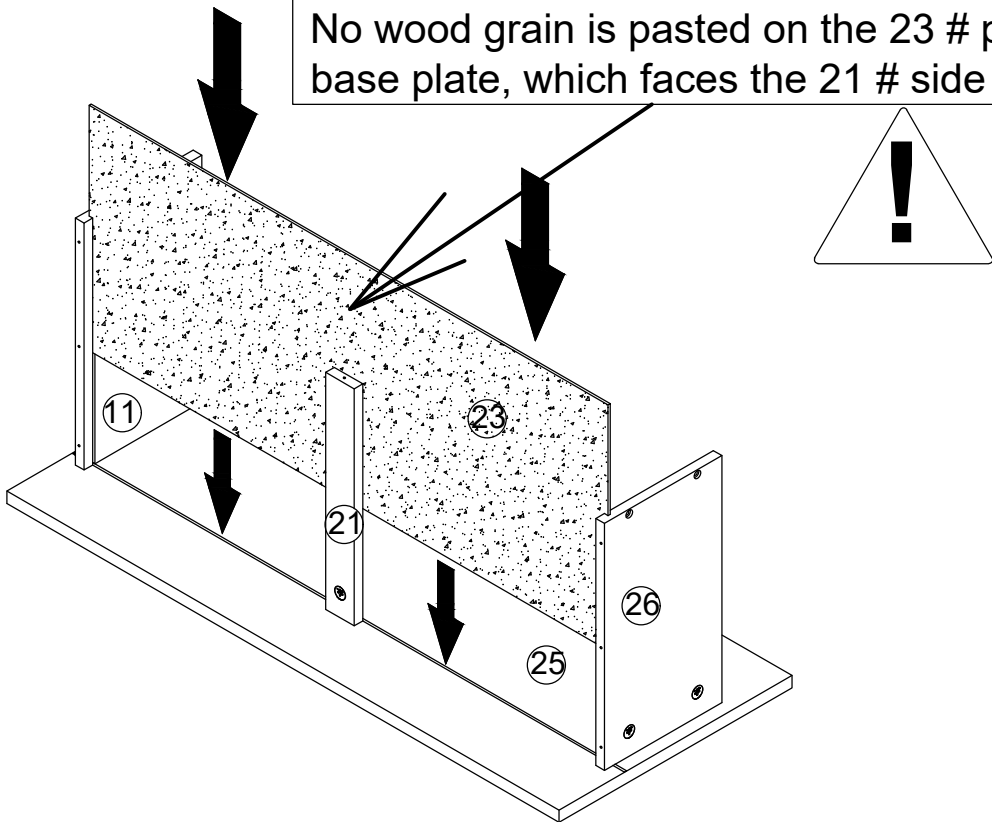

35

No wood grain is pasted on the 23 # pumping base plate, which faces the 21 # side



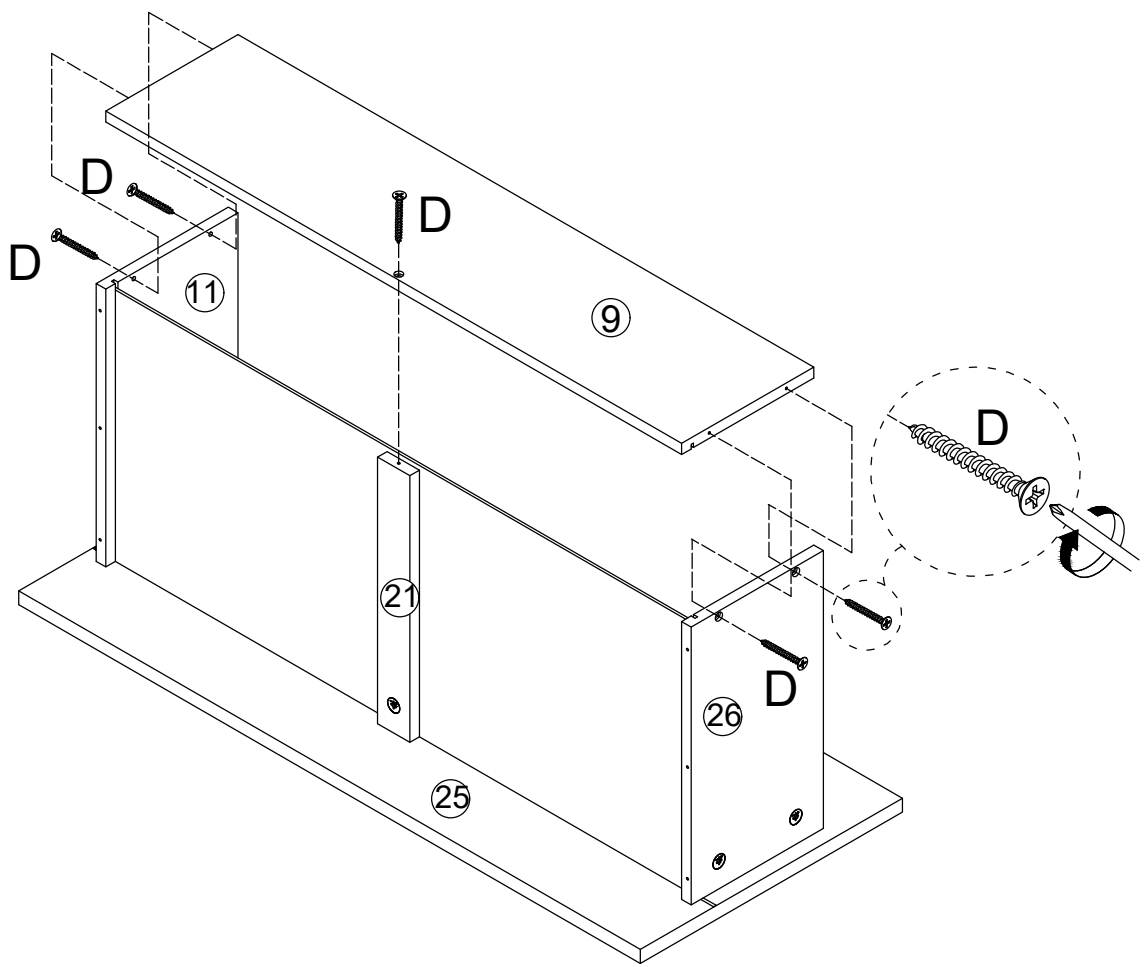

36



D	x5
	
Ø4x35mm	

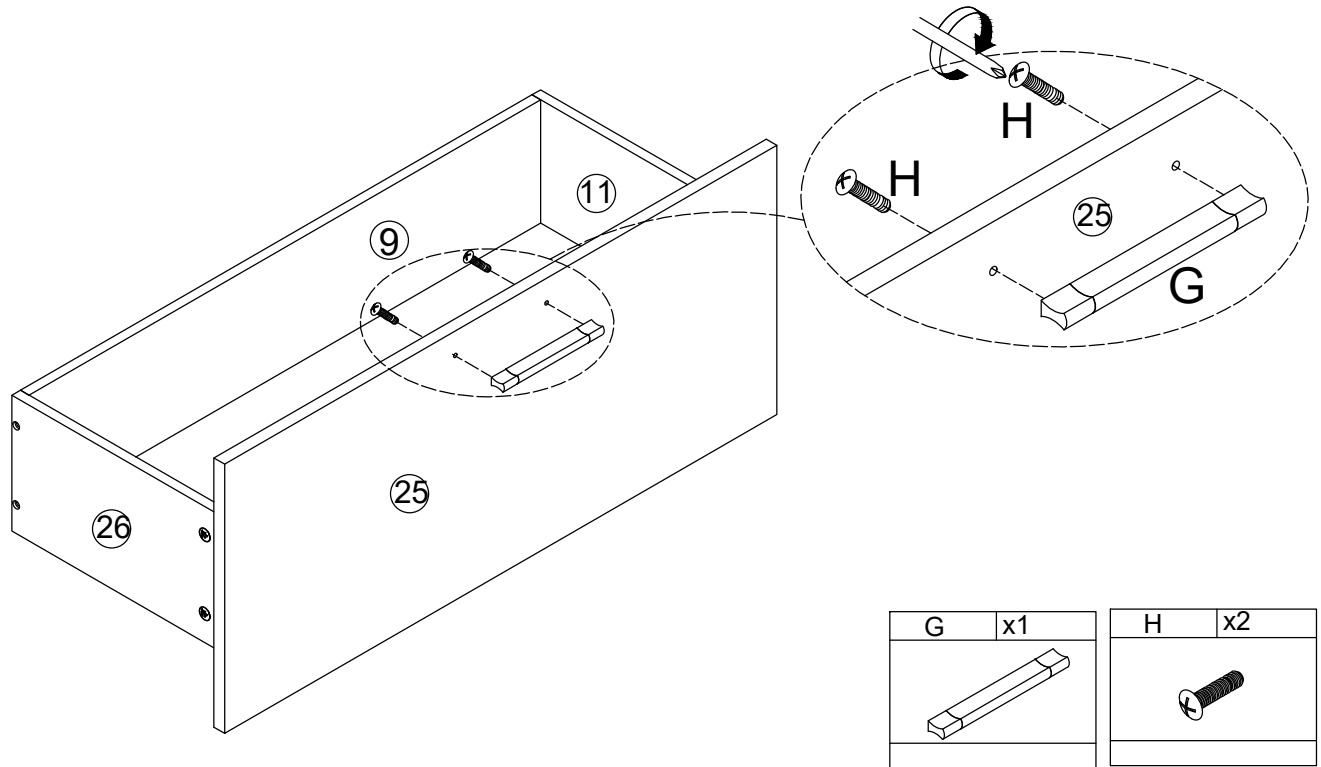

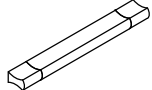
37

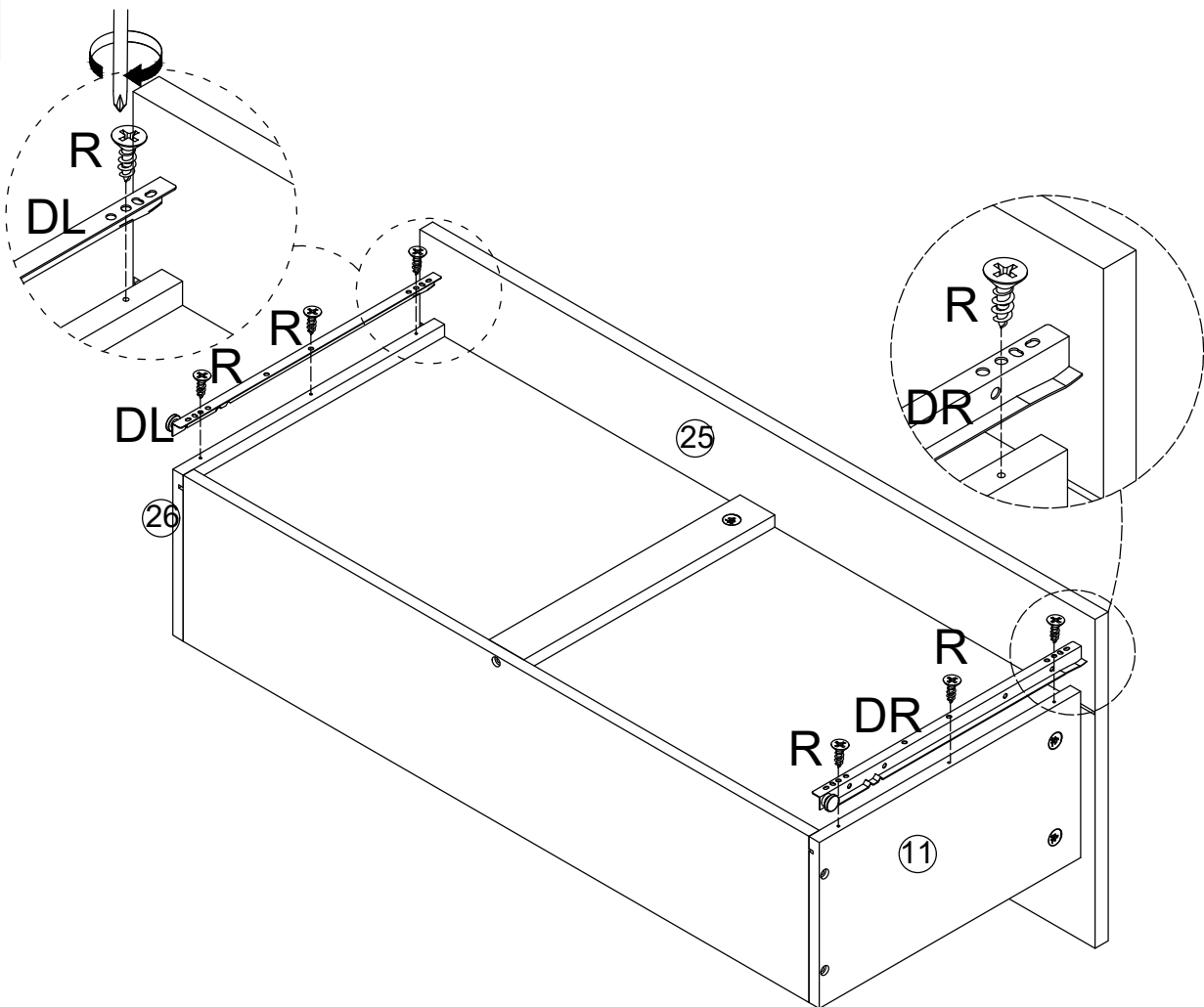

G	x1	H	x2
			

38



R	x6	DL	x1	DR	x1
					
Ø3.5x10mm		L300mm		L300mm	



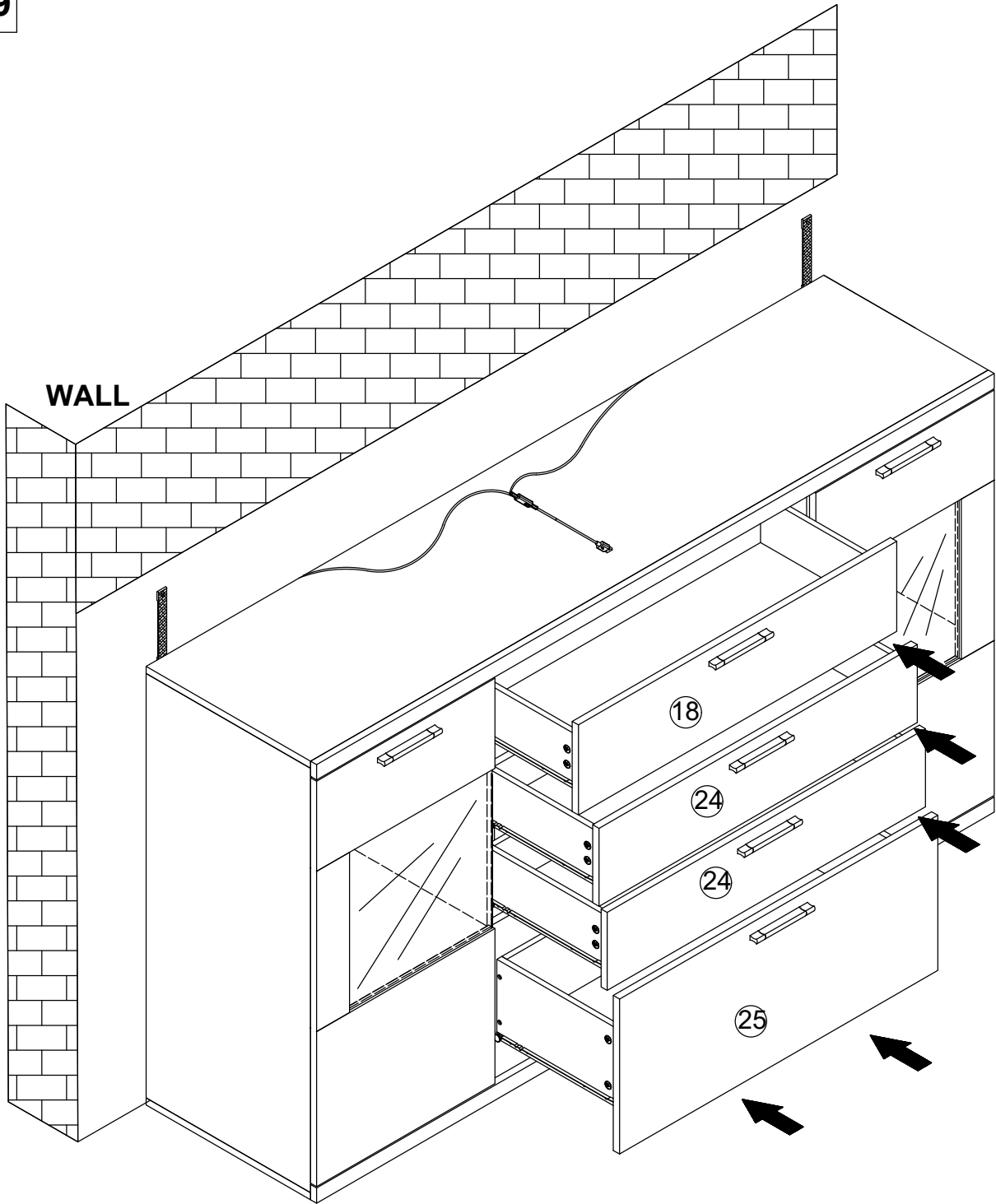

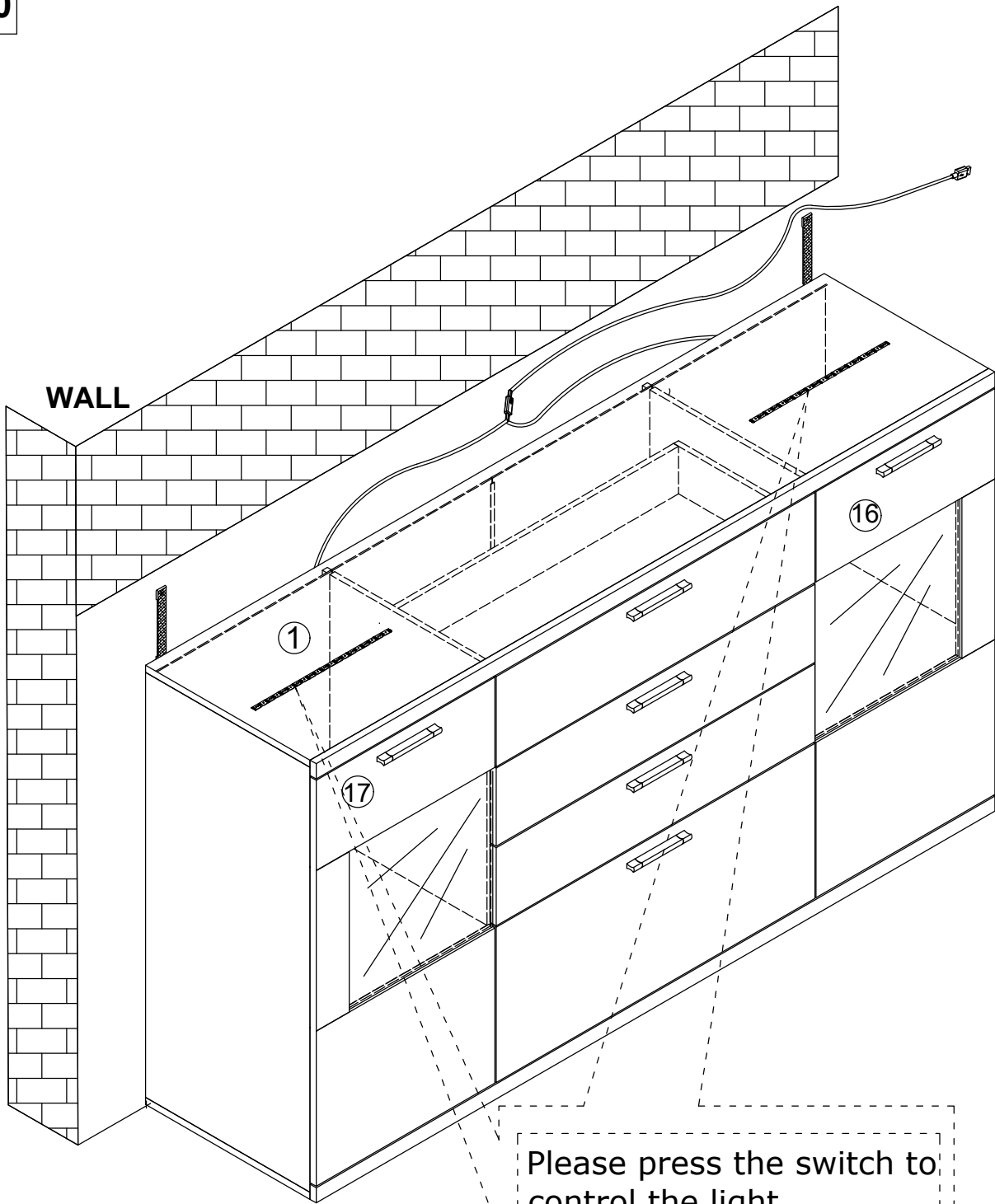

Please press the switch to control the light

