

ASSEMBLY INSTRUCTION

Item Number: WF317763 / WF317764

Upholstered Bed: 90x190

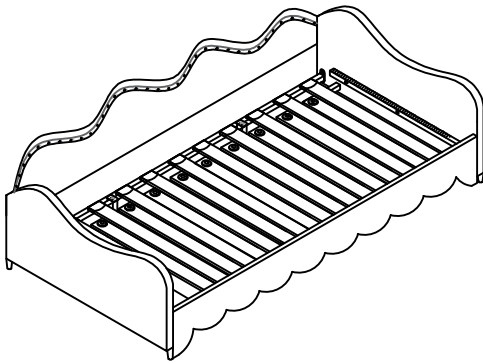

TIPS





1. This product is divided into 2 parcels for delivery. They may not arrive at the same time. Please wait patiently.

2. Please read the instructions fully before assembly. These instructions include important information which could ensure correct assembly. We have been working on providing high quality products for you. However, in the rare instance that your product is defective, missing parts or there are some issues, please don't hesitate to contact our customer service to submit parts requirements, assembly suggestion, or warranty claims, and we will give the best solution as soon as possible. If necessary, we need you to provide some more clear pictures of the issue.

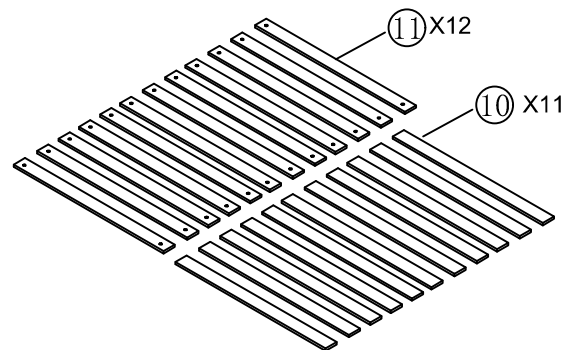
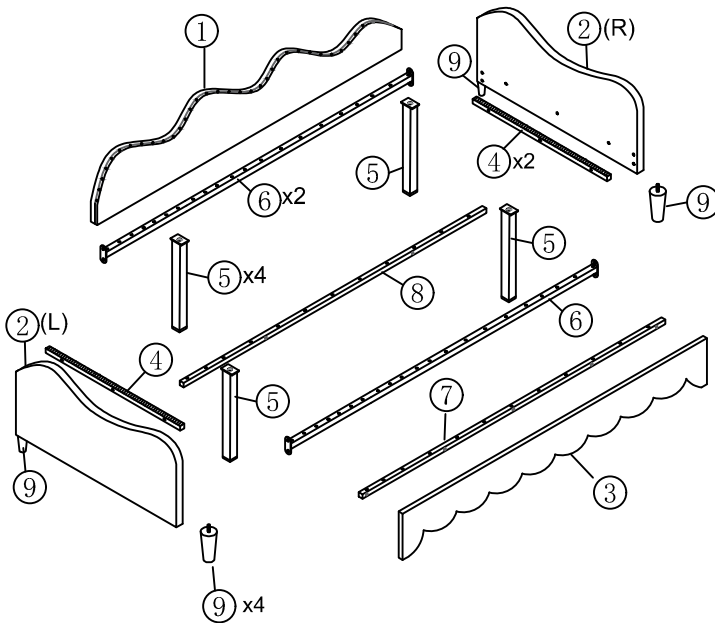
3. Insert the screws in holes and tighten the screws, but not too tight, 70%~80% is ok, finally tighten all the screws. If some issues happened that some screws can not target to the hole or some parts are difficult to install, please adjust the tightness of the screws.



4. 2 people are recommended to finish



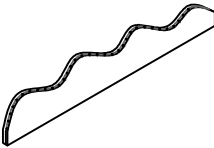
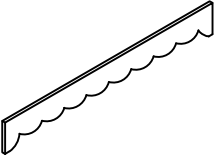

Parts List			Hardware List		
NO	ITEM	QTY	NO	ITEM	QTY
1	Backrest	1	A	Allen Key 	1
2	Armrest	2	B	Bolts (M8x50mm) 	15
3	Front board	1	C	Bolts (M8x25mm) 	22
4	Armrest support bar	2	D	Bolts (M8x18mm) 	16
5	Support legs	4	E	Power adapter 	1
6	Metal bar	2	F	Four hole iron 	2
7	Front board bar	1	G	End slats cap 	22
8	Middle bar	1	H	Remote control 	1
9	Legs	4			
10	Slats	11			
11	Slats	12			

Part List

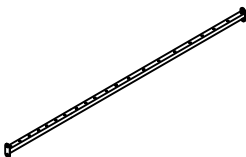
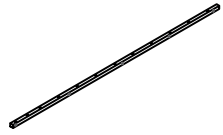
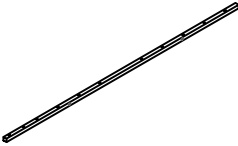
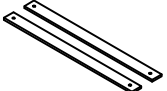
WF317764

1  Backrest-1pc	3  Front board-1pc	4  Armrest support bar-2pcs
6  Metal bar-2pcs	7  Front board bar-1pc	8  Middle bar-1pc
11  Slats-2pcs		

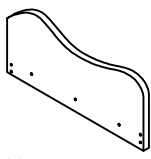
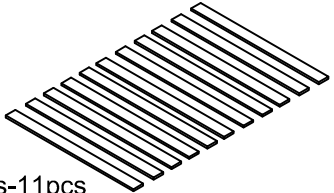
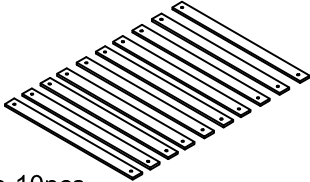
Hardware List+WF317763

2  Armrest-2pcs	10  Slats-11pcs	11  Slats-10pcs
9  Legs-4pcs	5  Support legs-4pcs	

Attention: Do not tighten the screws before completing the entire installation. If you have any difficulty with the installation process, please feel free to contact us.

Step 1 x2

Fix the legs ⑨ to the Armrest ② .

(Befestigen Sie die Beine ⑨ an der Armlehne ②.)

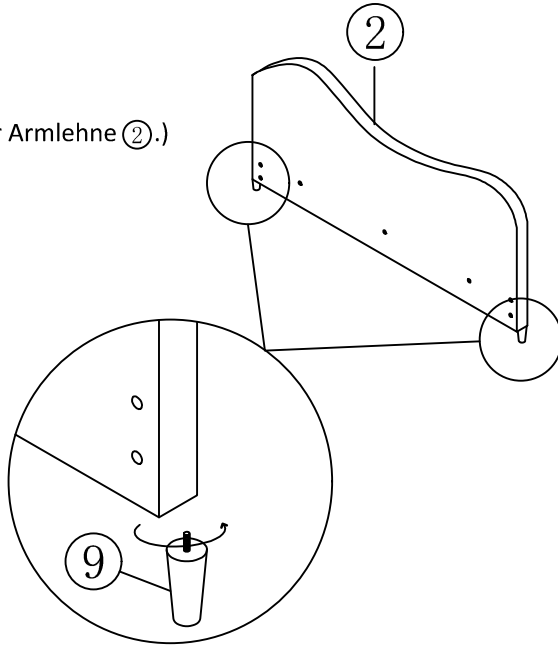



Step 2X2

Connect Armrest support bar ④ to the Armrest ② with Bolts B by using Allen key A.

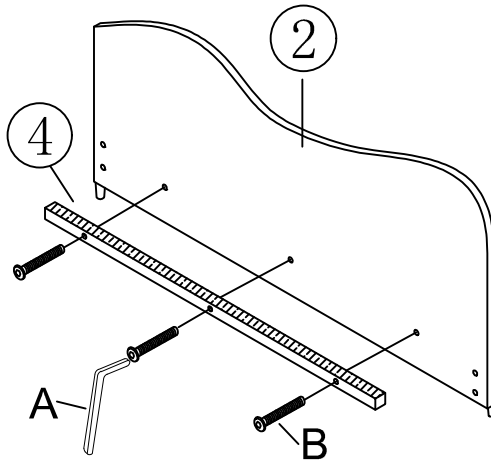
(Verbinden Sie Armlehnenstütze ④ mit der Armlehne ② mit Schrauben B mit Inbusschlüssel A.)





A Allen Key	B Bolts x 6
	 M8X50mm

Step 3

Fix the Metal bar ⑥ to the Armrest ② with Bolts D by using Allen key A.

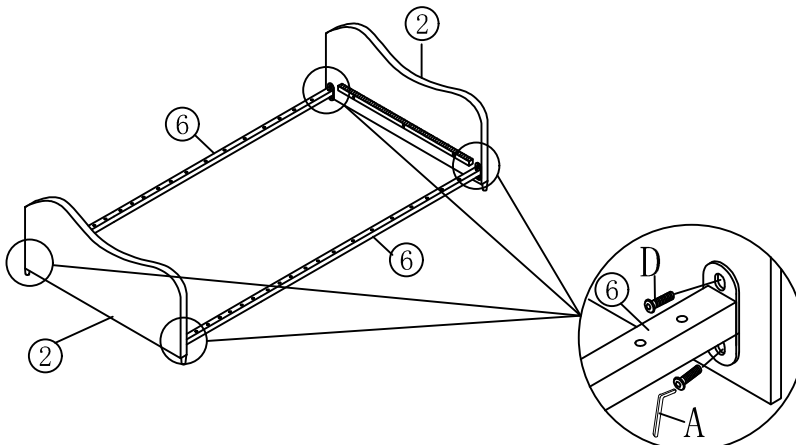
(Fixieren Sie die Metallstange ⑥ mit Schrauben D an der Armlehne ② mit Inbusschlüssel A.)







Allen Key	D Bolts x 8
	 M8X18mm

Step 4

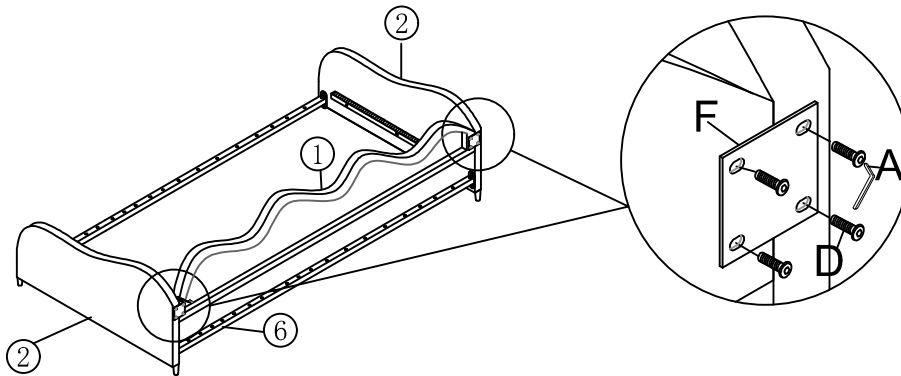
Fix the Backrest ① to the Armrest ② with Bolts D and Four hole iron F by using Allen key A.

(Fixieren Sie die Rückenlehne ① an der Armlehne ② mit Schrauben D und Vierloch Eisen F mit Inbusschlüssel A.)





Allen Key 	F Four hole iron x 2 	D Bolts x 8  M8X18mm
--	---	---

Step 5

Fix the two Support legs ⑤ to the Metal bar ⑥ which under the backrest with Bolts B by using Allen key A.

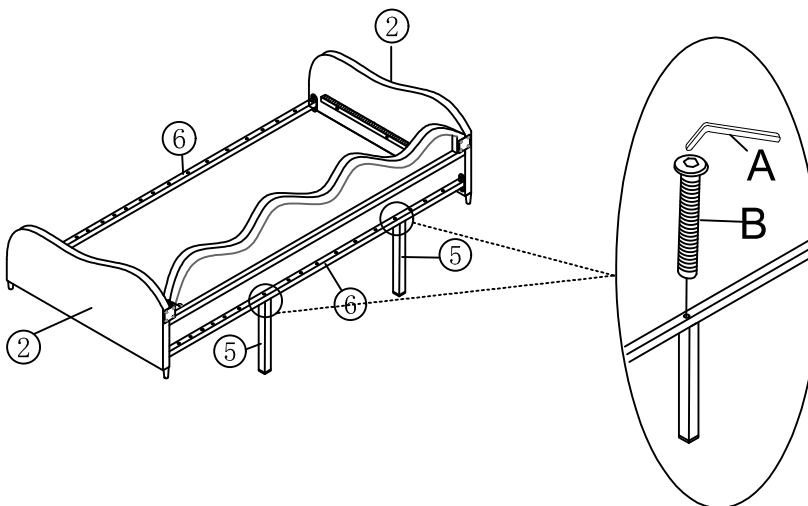
(Befestigen Sie die beiden Stützbeine ⑤ an der Metallstange ⑥, die unter der Rückenlehne mit Schrauben B mit Inbusschlüssel A liegt.)





Allen Key 	B Bolts x 2  M8X50mm
--	---

Step 6

Fix the Front board bar ⑦ to the Front board ③ with Bolts B by using Allen key A.

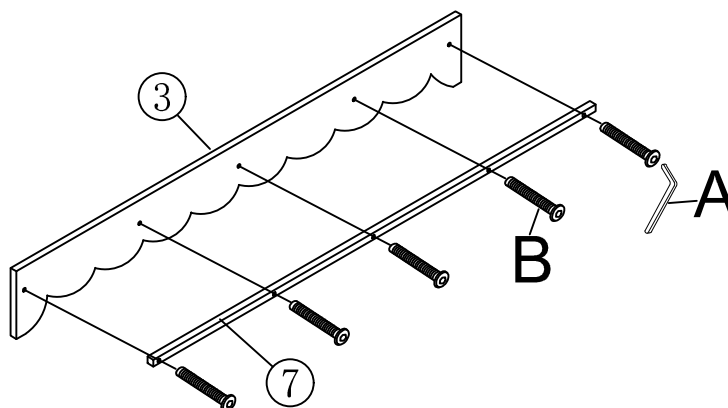
(Befestige die Front Board Bar ⑦ mit Schrauben B mit Inbusschlüssel A an der Front Board ③.)



Allen Key 	B Bolts x 5  M8X50mm
--	---

Step 7

Put Middle bar ⑧ on the Armrest support bar ④, then fix the Slats ⑪ to the Middle bar ⑧ and Front board bar ⑦ with Bolts C by using Allen Key A.
Fix another two support legs ⑤ to the Middle bar ⑧ with Bolts B by using Allen Key A. Please notice that the legs ⑤ and the forth slat (from each side) use the same hole.

(Setzen Sie Mittelleiste ⑧ auf die Armlehne Stützleiste ④, dann befestigen Sie die Lamellen ⑪ an der Mittelleiste ⑧ und Vorderbordleiste ⑦ mit Schrauben C mit Inbusschlüssel A.

Befestigen Sie weitere zwei Stützbeine ⑤ mit Schrauben B am Mittelbalken ⑧ mit Inbusschlüssel A. Bitte beachten Sie, dass die Beine ⑤ und die vierte Lamelle (von jeder Seite) das gleiche Loch verwenden.)

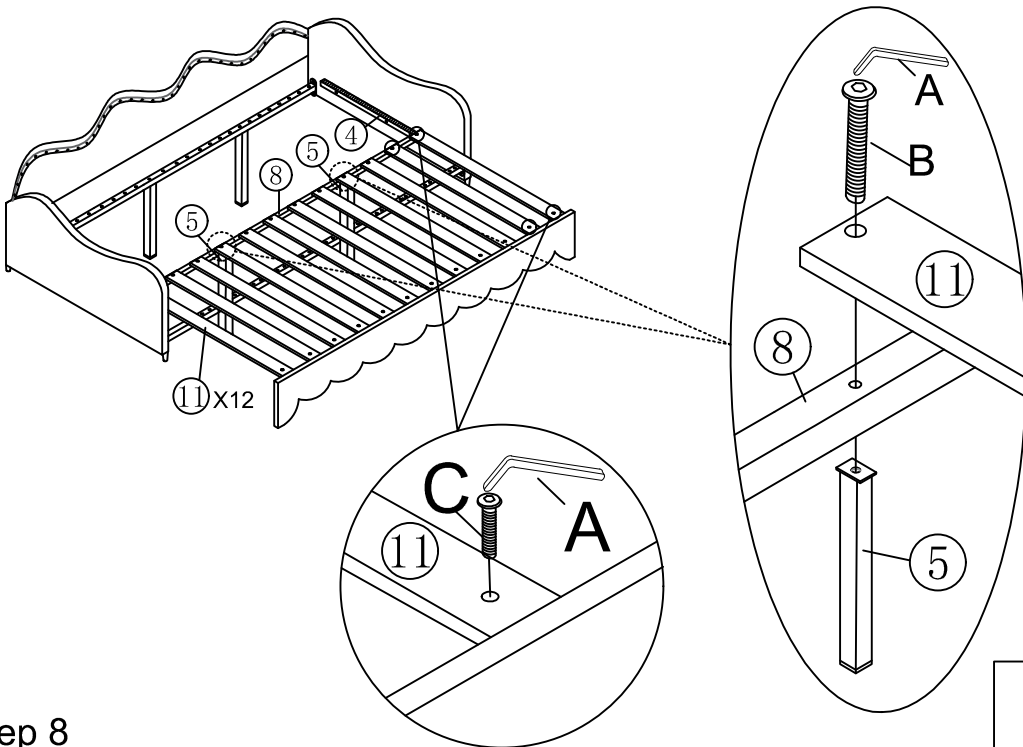

Step 8

Fix the slats ⑩ to the metal bar ⑥ with slats cap G.
(Fixieren Sie die Lamellen ⑩ an der Metallstange ⑥ mit Lamellenkappe G.)

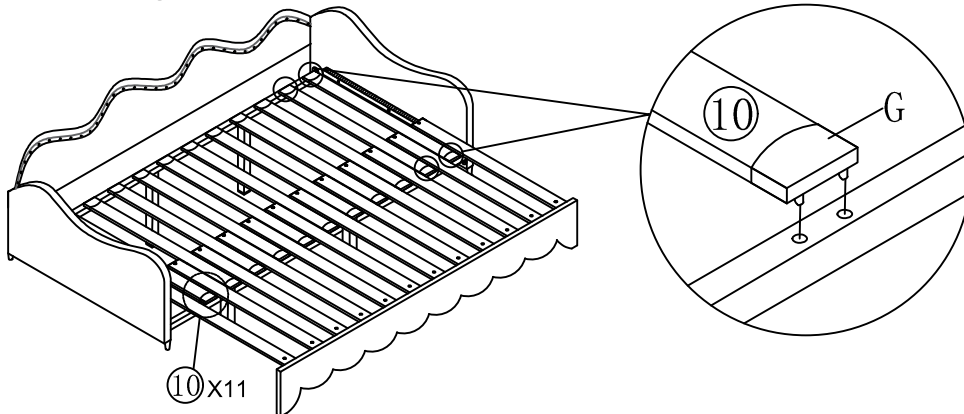

Step 9

Fix the Power adapter E to the LED strip and connect the Power, then assembly is finished. Please enjoy your bed.
(Befestigen Sie das Netzteil E am LED-Streifen und schließen Sie das Netzteil an, dann ist die Montage abgeschlossen. Bitte genießen Sie Ihr Bett.)

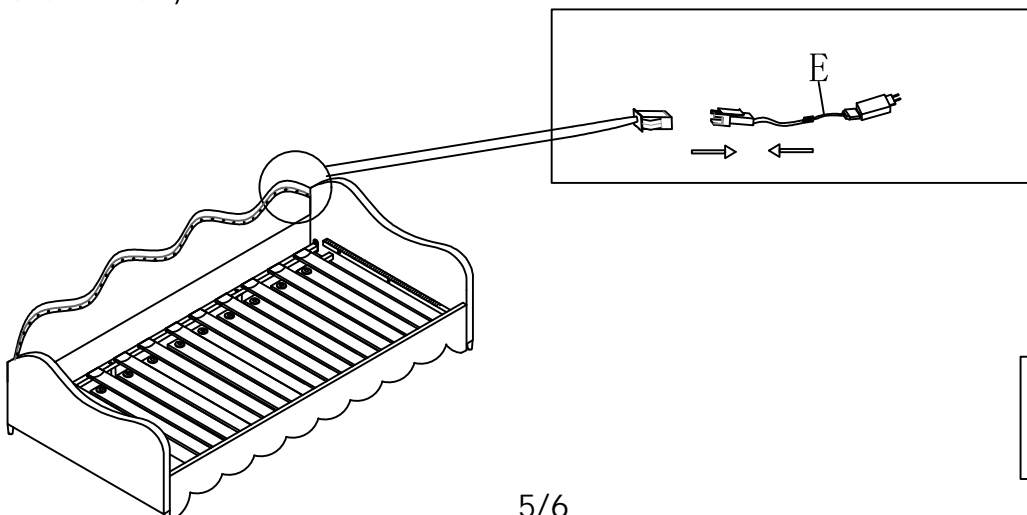

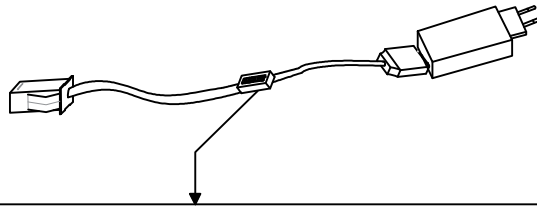

NOTICE:

You can scan the QR code here and download an app that can control the color of the light strip like a remote control. When your phone plays music through the app, the color of the light strip will also change according to the strength of the music

