

(D) *Montageanleitung*

(NL) *Handleiding voor de montage*

(TR) *Montaj talimatı*

(FR) *Notice de montage*

(CZ) *Montážní návod*

(HU) *Szerelési útmutató*

(GB) *Assembly instructions*

(PL) *Instrukcja montażu*

(RU) *Инструкция по монтажу*

(IT) *Istruzioni di montaggio*

(SK) *Návod na montáž*

(RO) *Instrucțiuni de montaj*

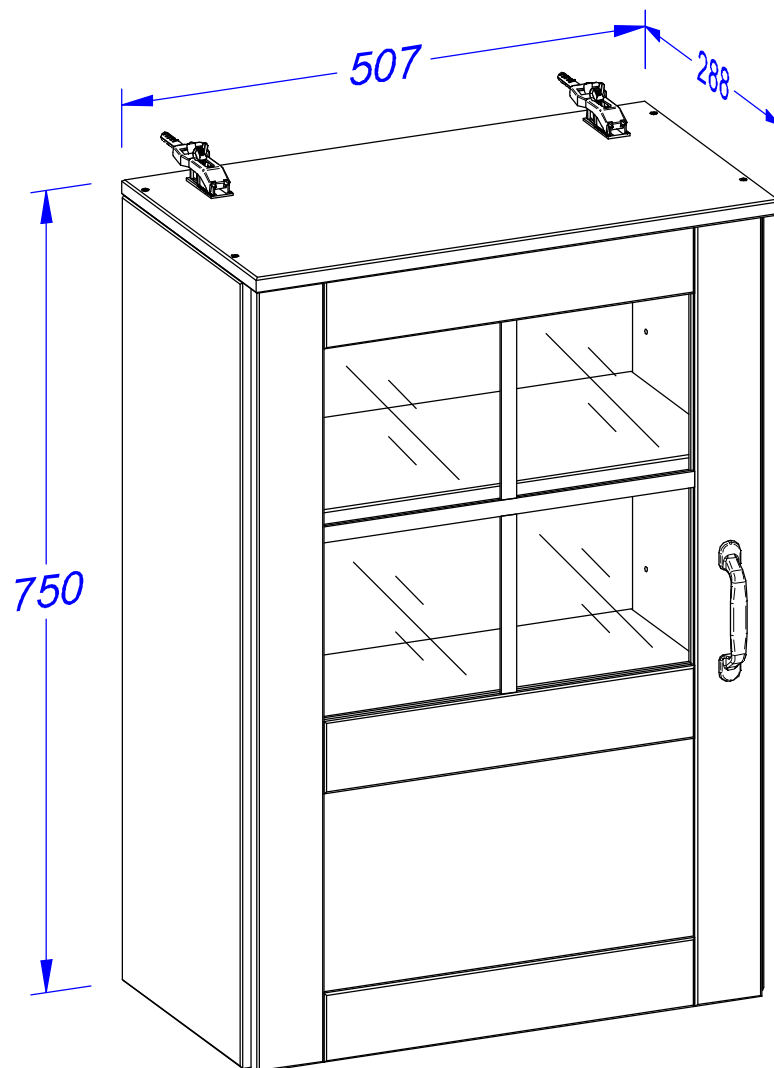

(D) *Montageanleitung*

(NL) *Handleiding voor de montage*

(TR) *Montaj talimatı*

(FR) *Notice de montage*

(CZ) *Montážní návod*

(HU) *Szerelési útmutató*

(GB) *Assembly instructions*

(PL) *Instrukcja montażu*

(RU) *Инструкция по монтажу*

(IT) *Istruzioni di montaggio*

(SK) *Návod na montáž*

(RO) *Instrucțiuni de montaj*

Name • Nom • Nome • Naam • Nazwa • Jméno •
Názov • Név • Denumire • Isim • Название

Nr. • No. • N° • Номер • Č • Sz

Typ • Type • Tip • Típus • Tipo • Тип

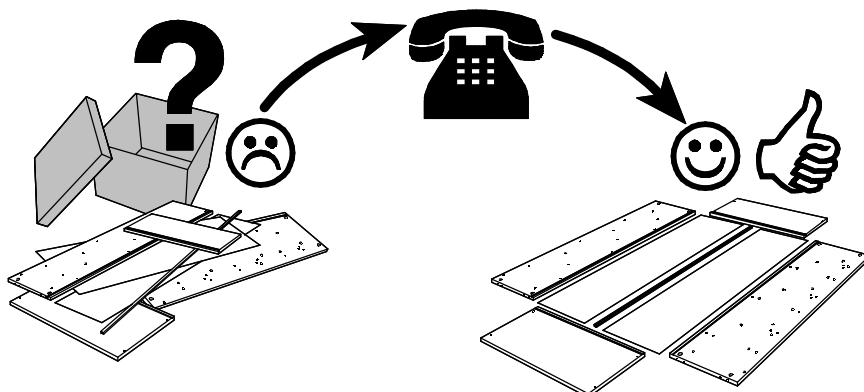
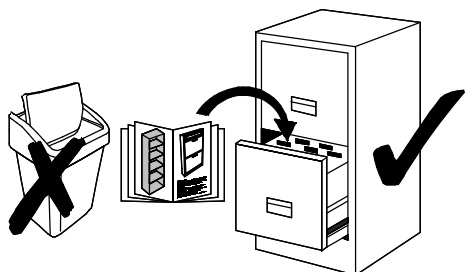

A	8 x	C	2 x	Ce	2 x	Dd	2 x	Ea	4 x	Fb	1 x
G	4 x	Ga	4 x	Hc	4 x	I	25 x	lb	1 x	Lk	1 x
N	8 x	No	1 x								

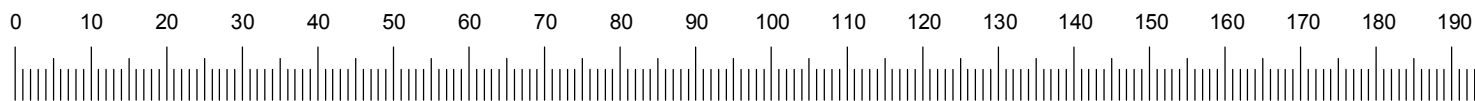
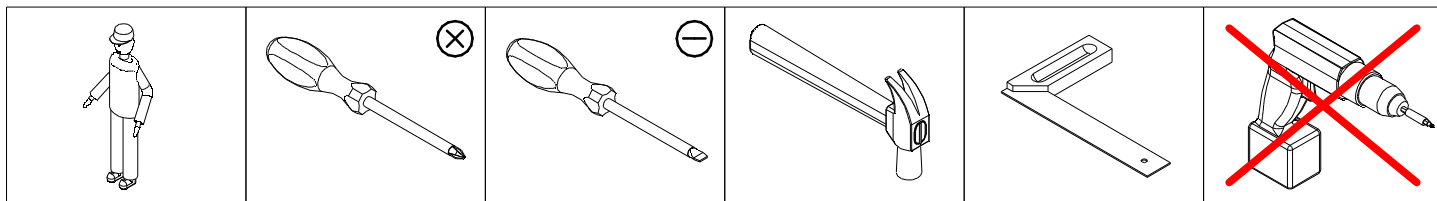

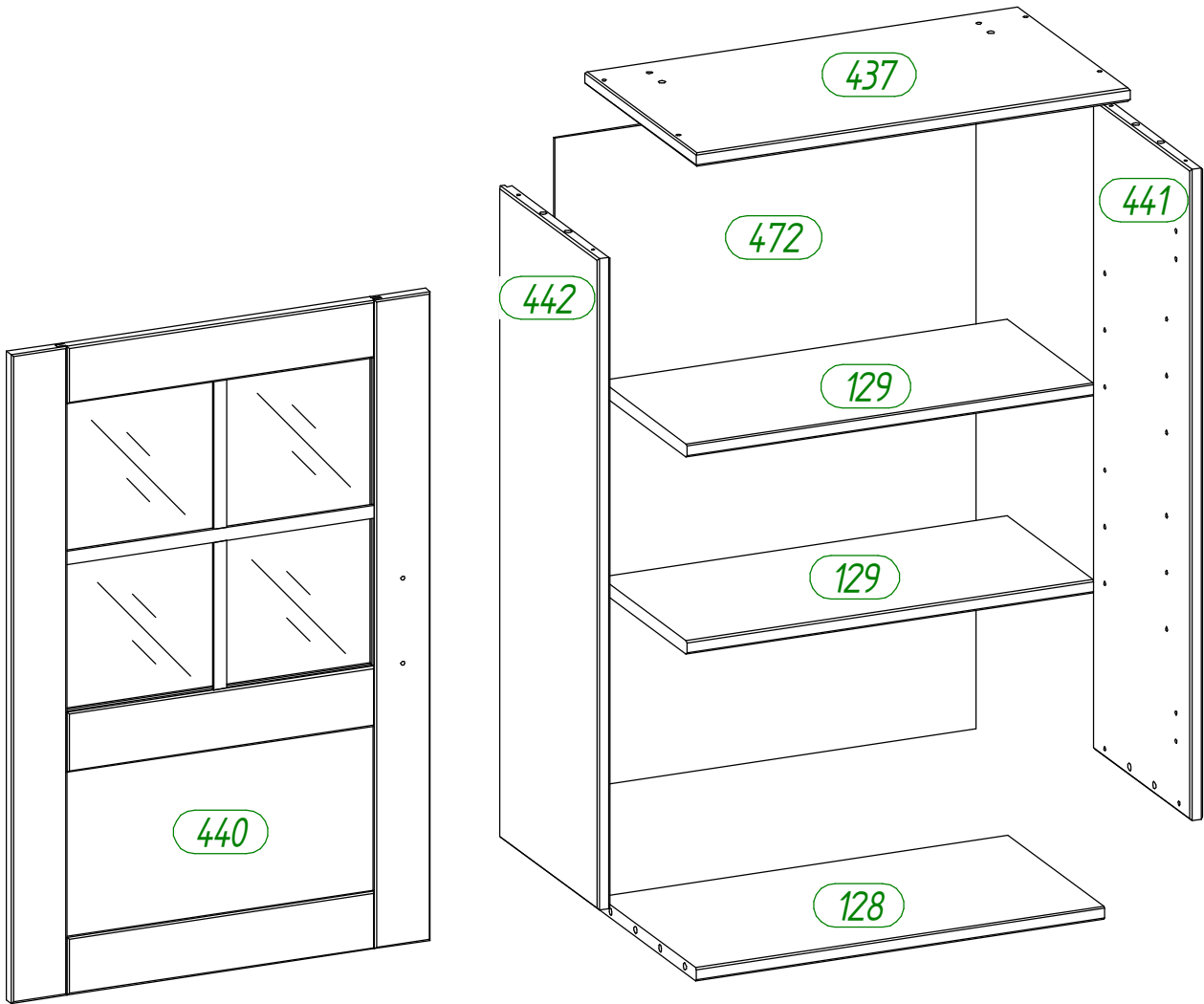

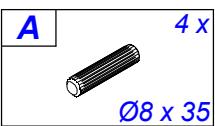
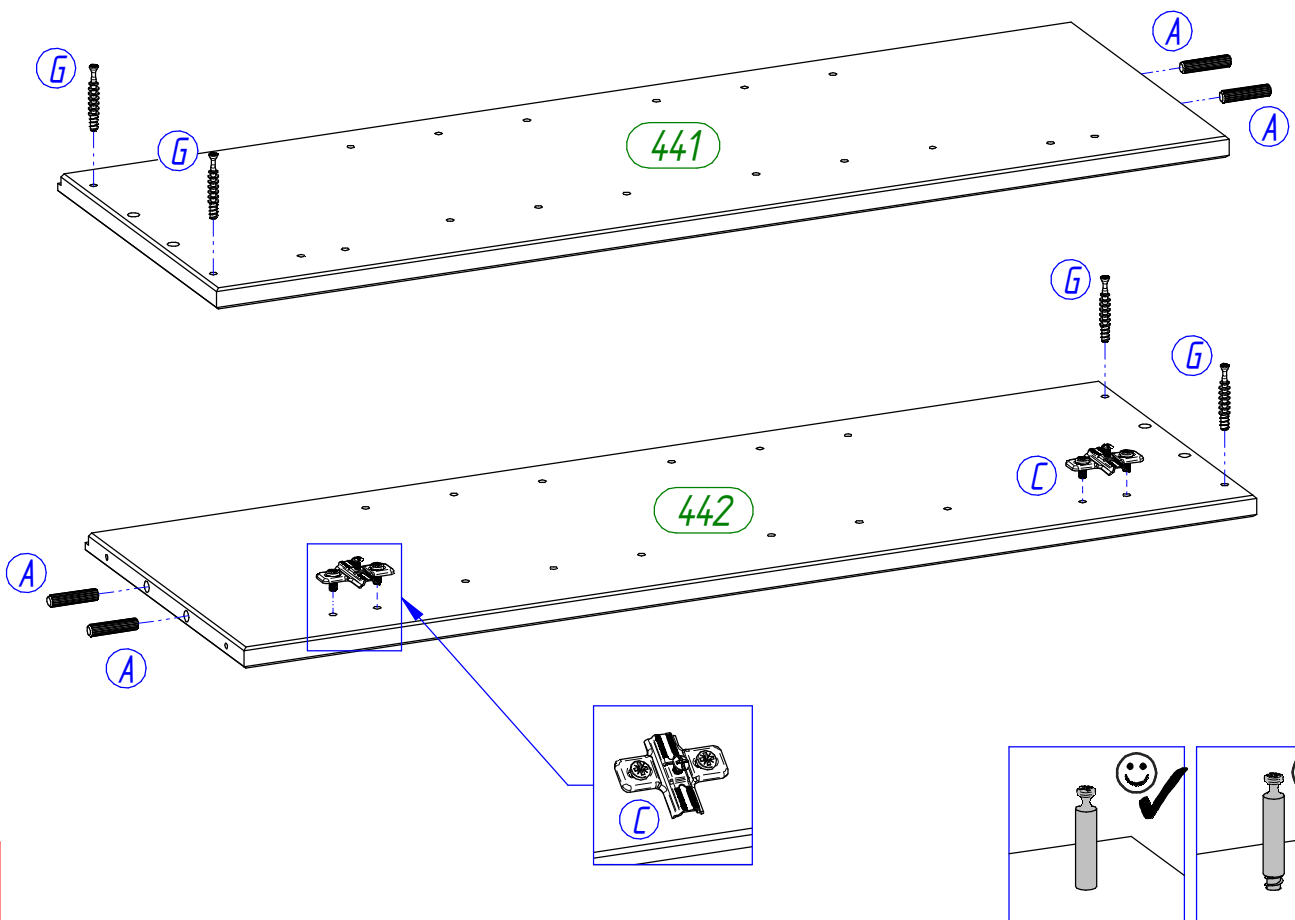
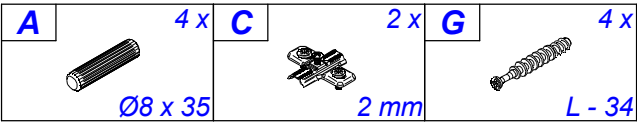
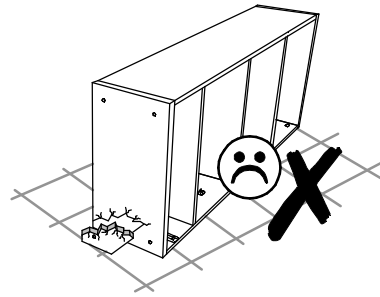
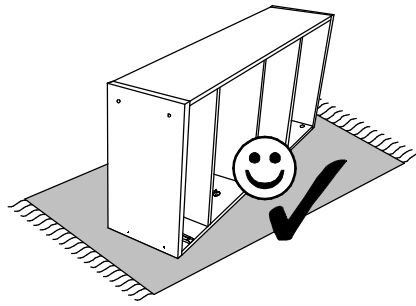

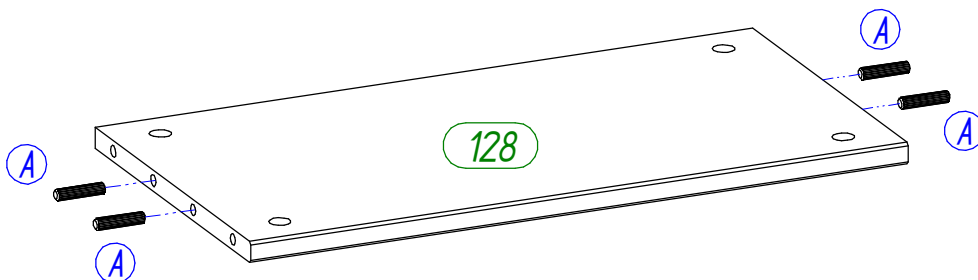

2

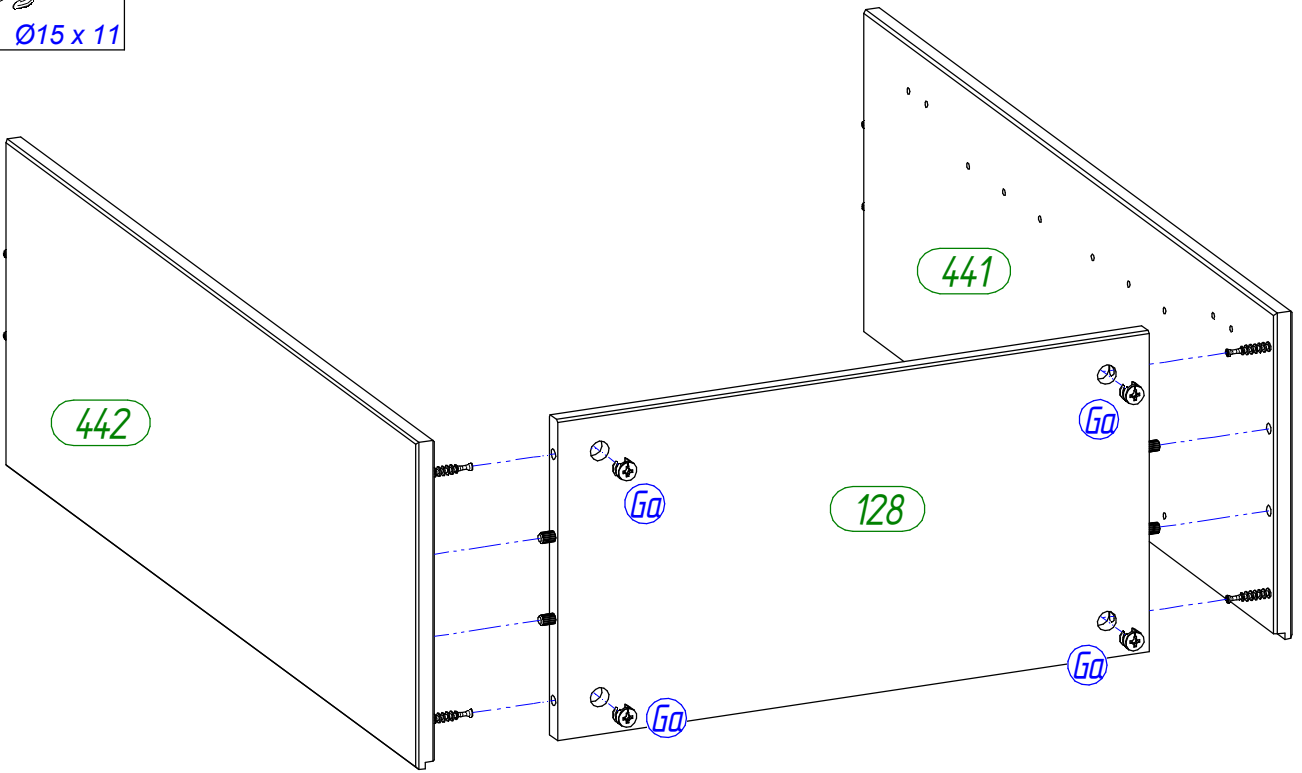

Ga 4 x

Ø15 x 11

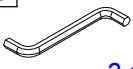

3

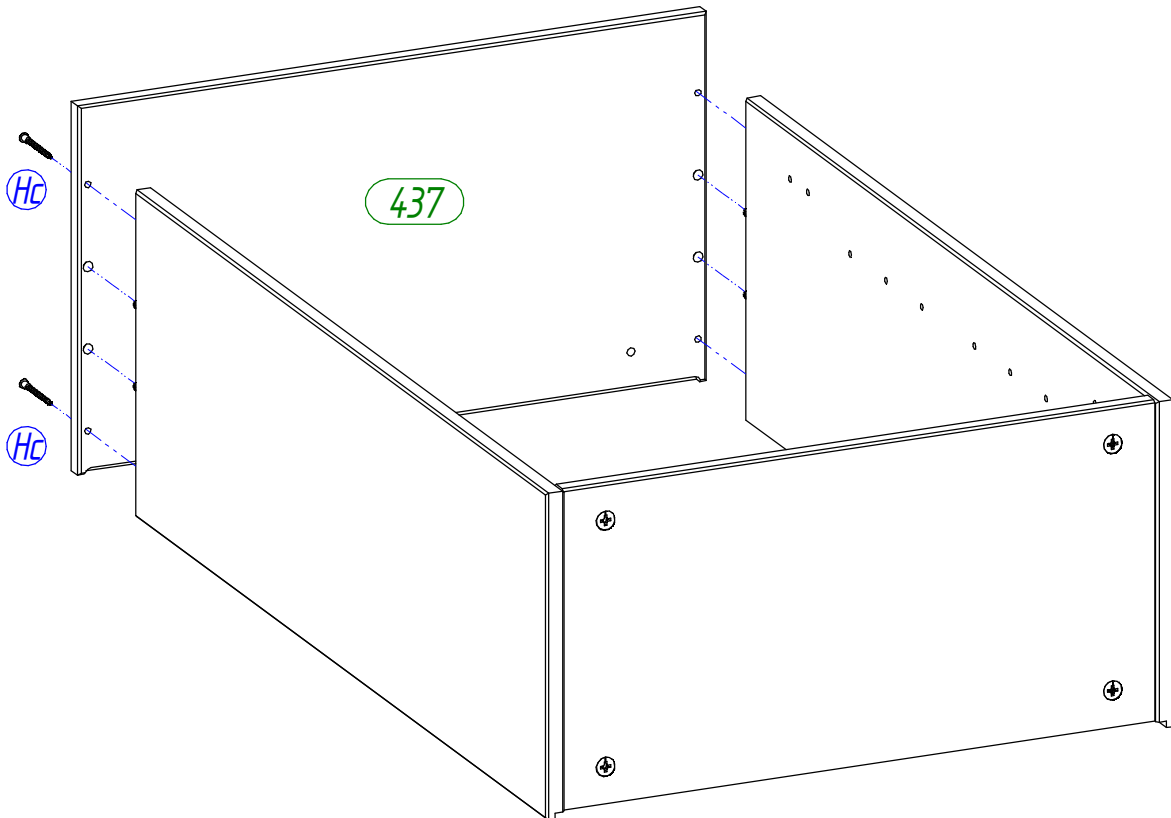
Fb 1 x **Hc** 4 x
 3 mm  Ø5 x 50





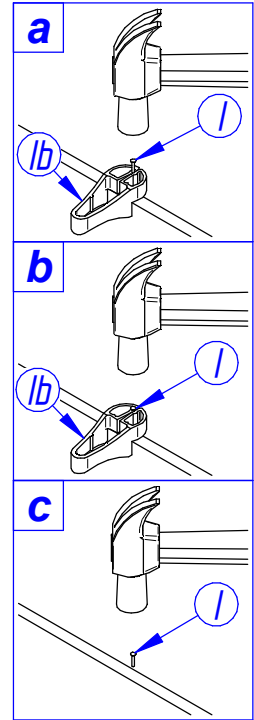
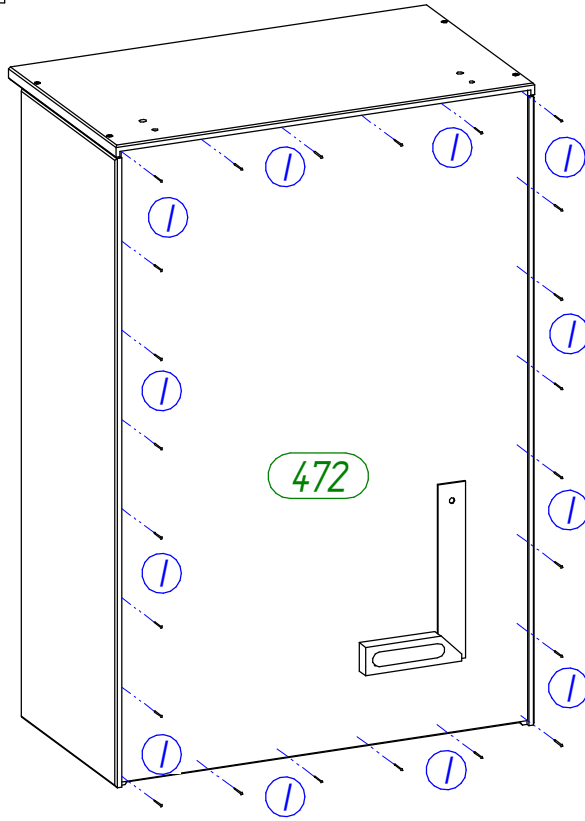
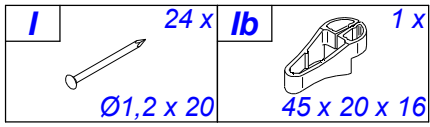

4

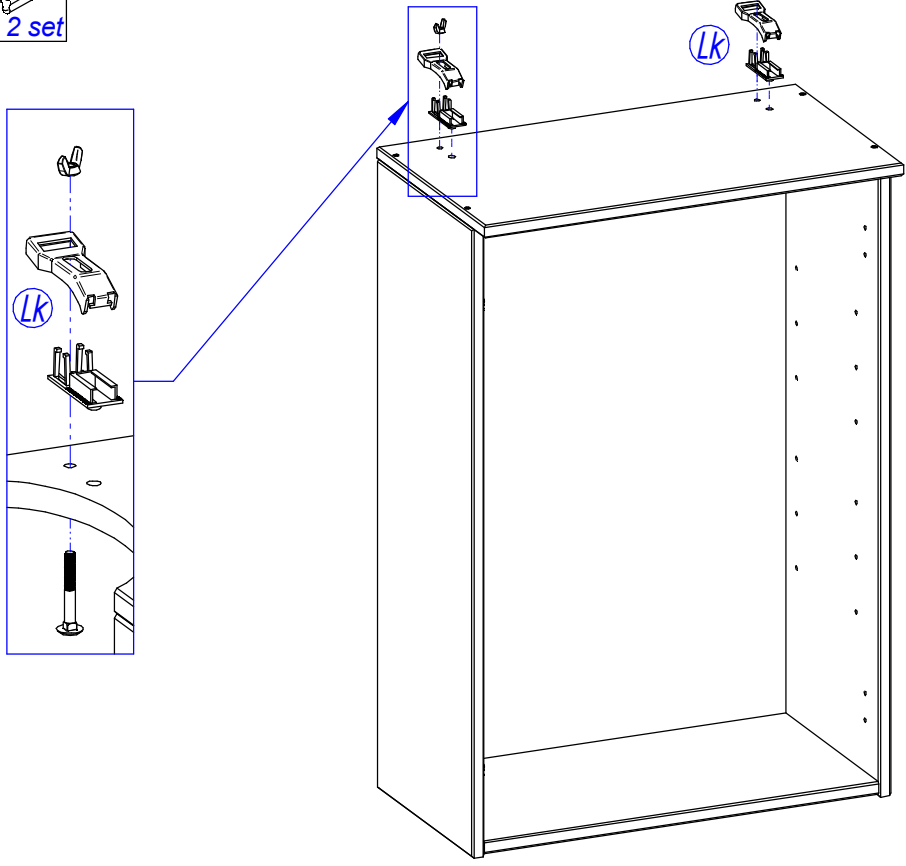
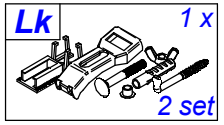

5

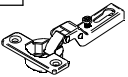

6

Ce	2 x	Dd	2 x	Ea	4 x	No	1 x
							
fk.9		M4 x 20		Ø3,5 x 15		131 x 20	

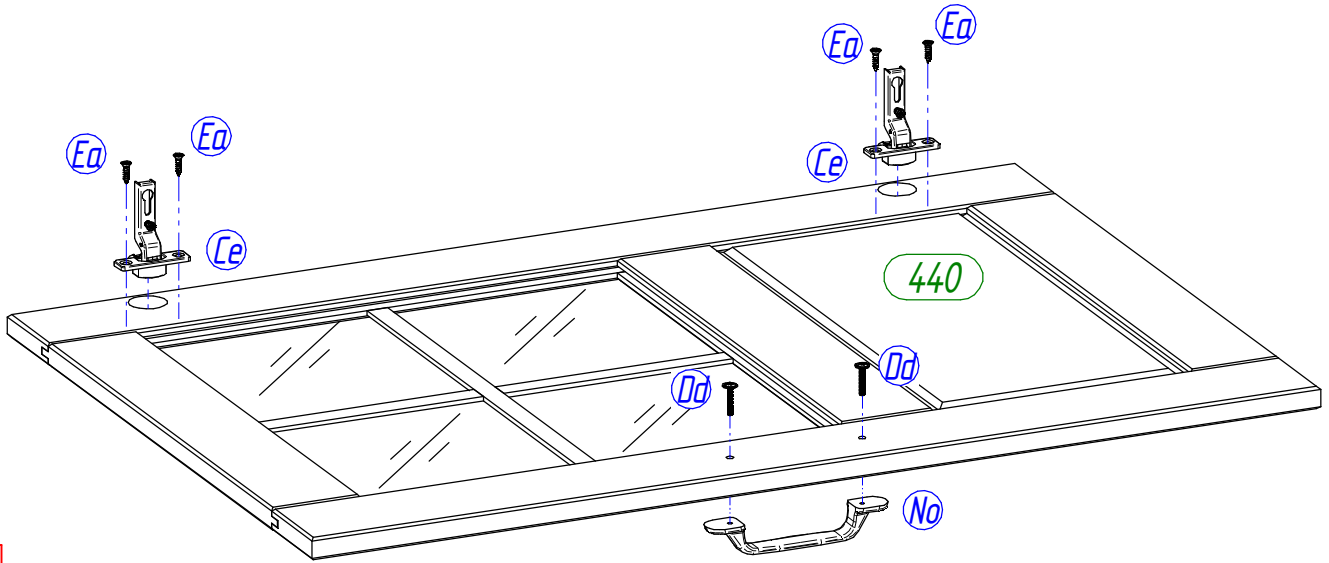

7

N	8 x
	
Ø5 / Ø5	

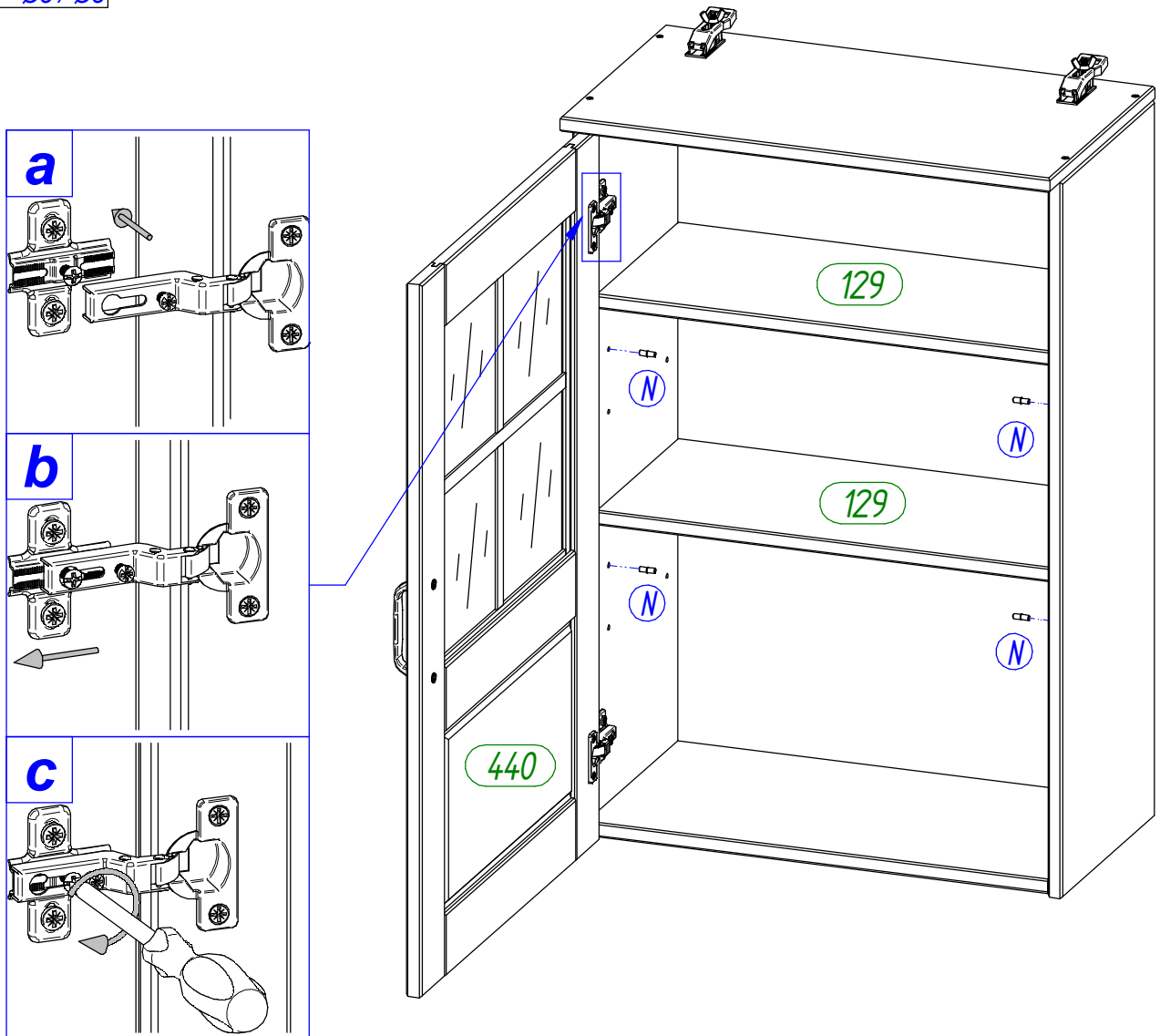

8

(D)	Bei einigen Wandtypen kann ein Spezialdübel erforderlich sein!
(GB)	For certain wall types, a special dowel may be necessary!
(NL)	Bij enkele muurtypes is een speciale plug misschien vereist!
(PL)	Do niektórych rodzajów ścian konieczne mogą być specjalne wkręty!
(TR)	Bazı duvar tiplerinde bunun için özel bir dübel gerekli olabilir!
(RU)	Для некоторых типов стен может потребоваться специальный дюбель!
(FR)	Pour certains types de murs il faut des chevilles spéciales !
(IT)	Per alcune strutture di parete può essere necessario un tassello speciale!
(CZ)	U některých typů stěn může být zapotřebí speciální hmoždinka!
(SK)	Pre niektoré druhy stien môže byť potrebná špeciálna hmoždinka!
(HU)	Egyes faltípusoknál speciális tiplít kell használni!
(RO)	Pentru unele tipuri de pereți este posibil să fie necesar un diblu special!

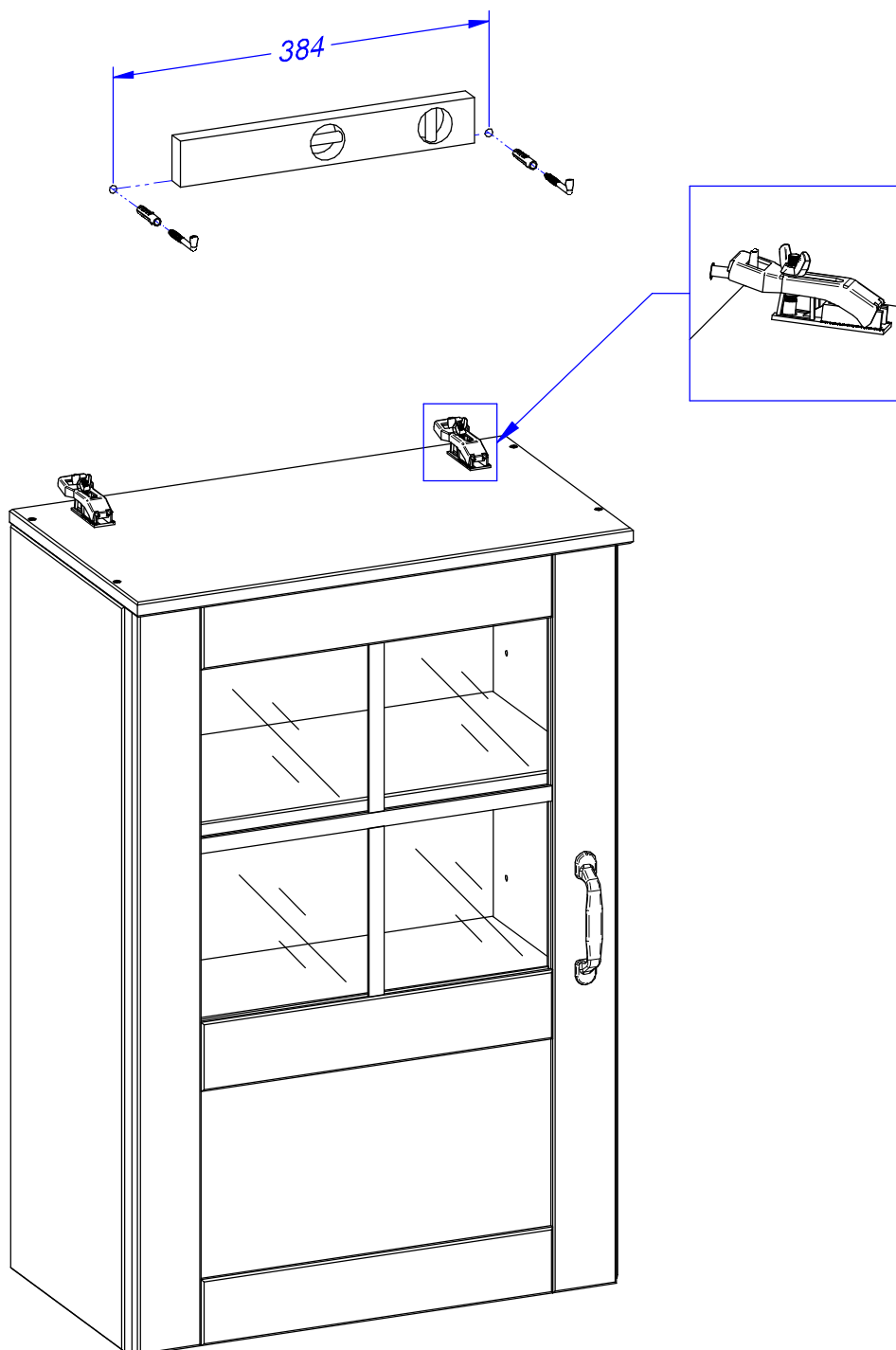

D	Türen einstellen (Scharniere justieren)
GB	Adjusting the doors (adjusting the hinges)
NL	Deuren instellen (scharnieren afstellen)
PL	Nastawić drzwi (wyrównać zawiasy)
TR	Kapıların ayarlanması (menteşelerin seviye ayarı)
RU	Регулировка дверей (регулировка шарнира)
FR	Régler les portes (ajuster les charnières)
IT	Sistemare le porte (regolare le cerniere)
CZ	Vyrovnejte dvířka (seřídte závěsy)
SK	Nastavenie dverí (nastavenie závesov)
HU	Állítsa be az ajtókat (állítsa be a zsanérokat)
RO	Reglare ușii (ajustare balamale)

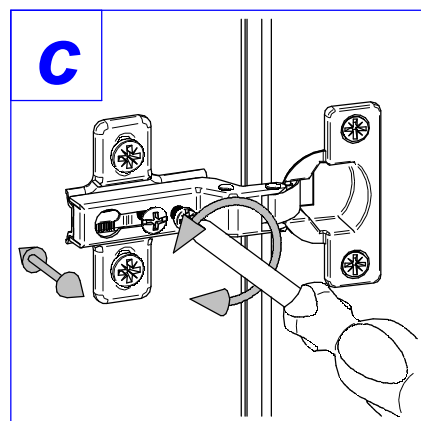
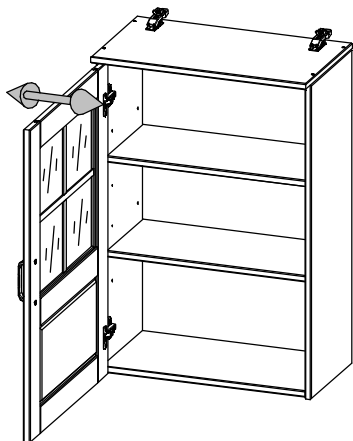
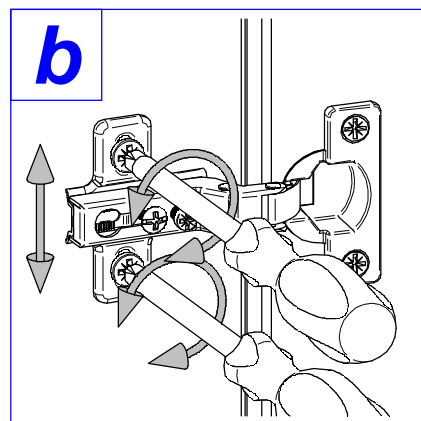
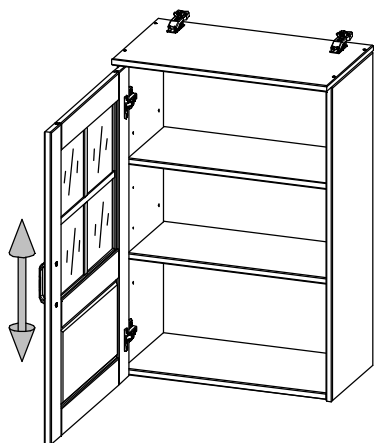
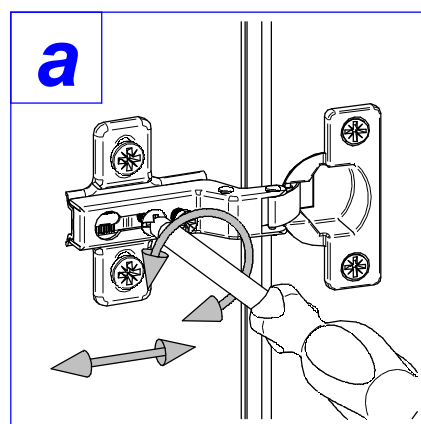
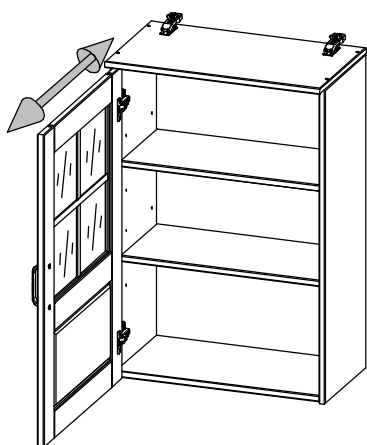







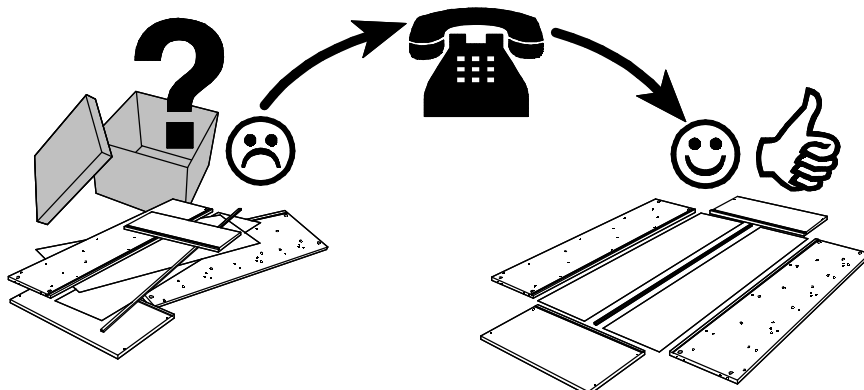
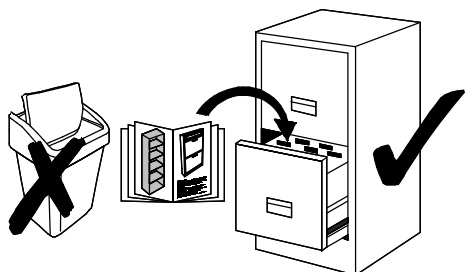

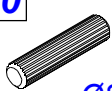
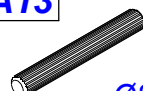

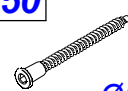
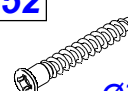
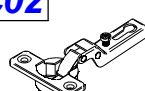

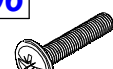

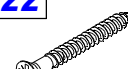

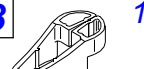

Name • Nom • Nome • Naam • Nazwa • Jméno •
Názov • Név • Denumire • Isim • Название

Nr. • No. • N° • Номер • Č • Sz

Typ • Type • Tip • Tipus • Tipo • Тип

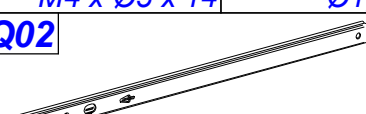

A10 18 x  Ø8 x 35	A13 2 x  Ø8 x 60	B03 6 x  Ø5,8 x 11	B50 12 x  Ø5 x 50	B52 4 x  Ø7 x 50	C02 4 x  fk.9
C20 4 x  2 mm	D02 2 x  M4 x 10	D06 6 x  M4 x 20	E17 10 x  Ø3,5 x 15	E22 4 x  Ø3,5 x 35	E38 1 x  Ø4,0 x 60
F02 1 x  3 mm	F04 1 x  4 mm	F08 1 x  45 x 20 x 16	G02 20 x  Ø15 x 11	G06 14 x  L - 34	G08 6 x  M4 / 7,0 x 34
G12 3 x  M4 x Ø5 x 14	I01 75 x  Ø1,2 x 20	K03 1 x  20 x 42 x 70	N01 28 x  Ø5 / Ø5	P23 3 x  131 x 20	
Q02 2 x  17 x 430					

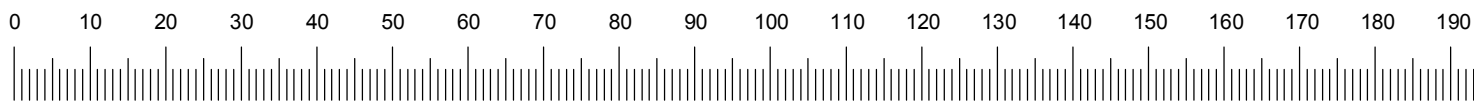
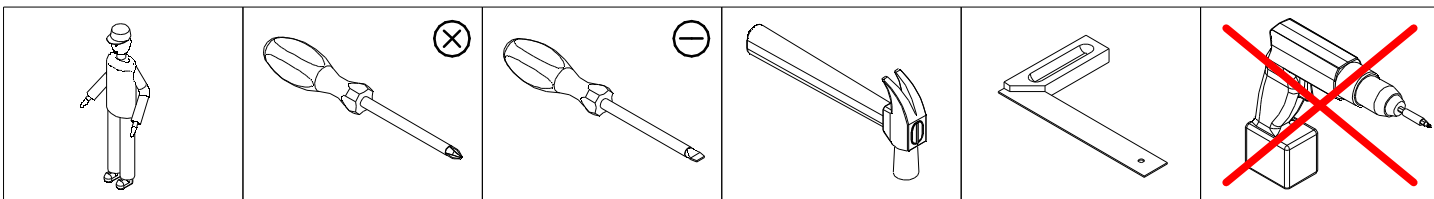

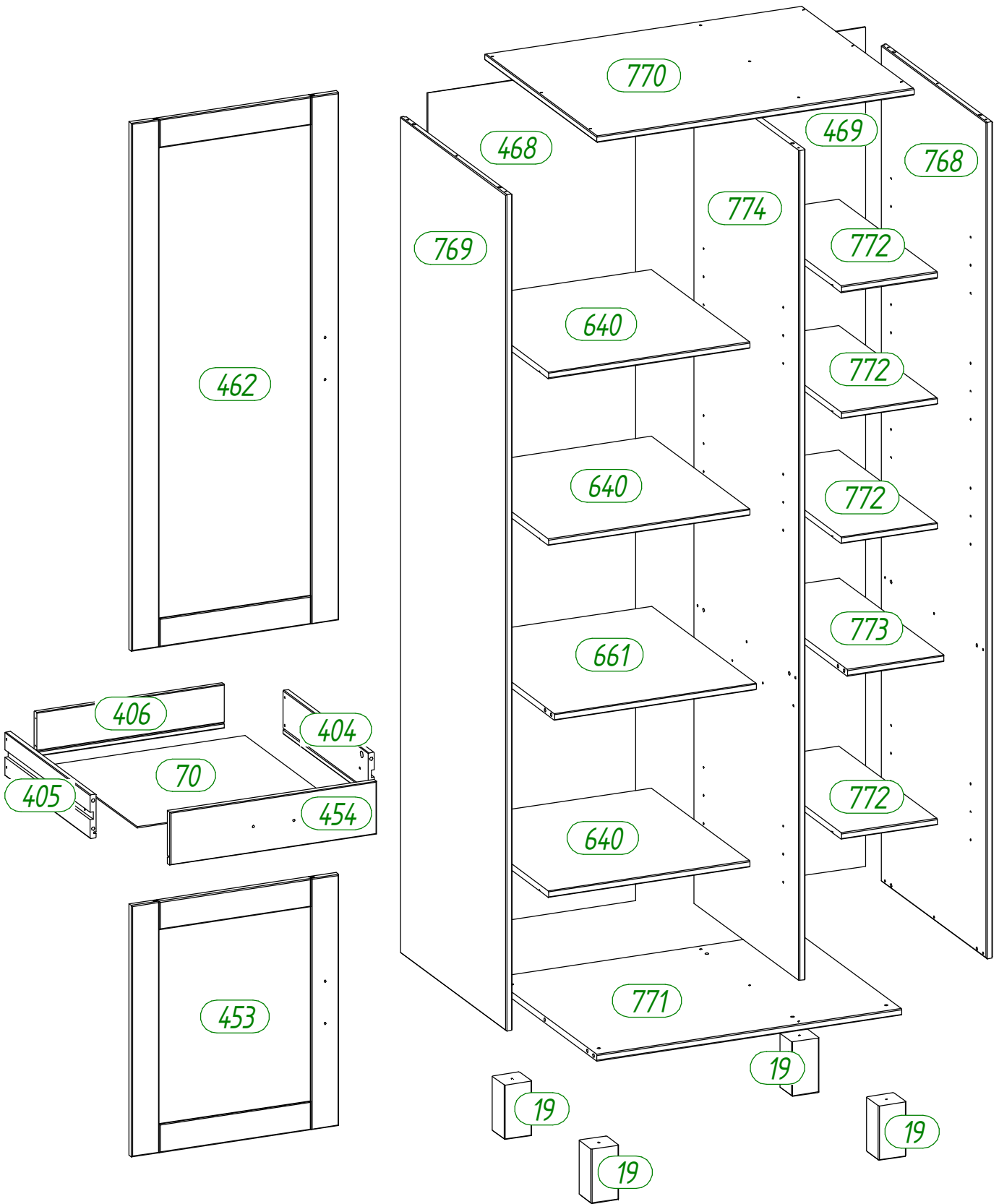

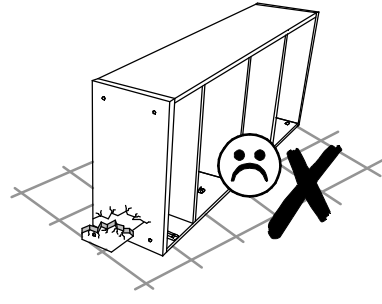
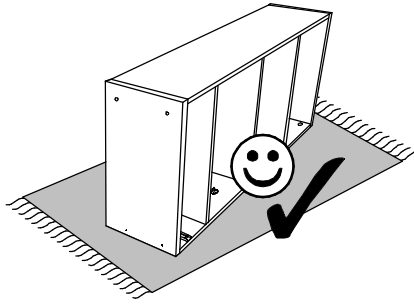

A10	4 x	B03	3 x	C20	4 x	G06	12 x	Q02	1 x
Ø8 x 35		Ø5,8 x 11		2 mm		L - 34		17 x 430	

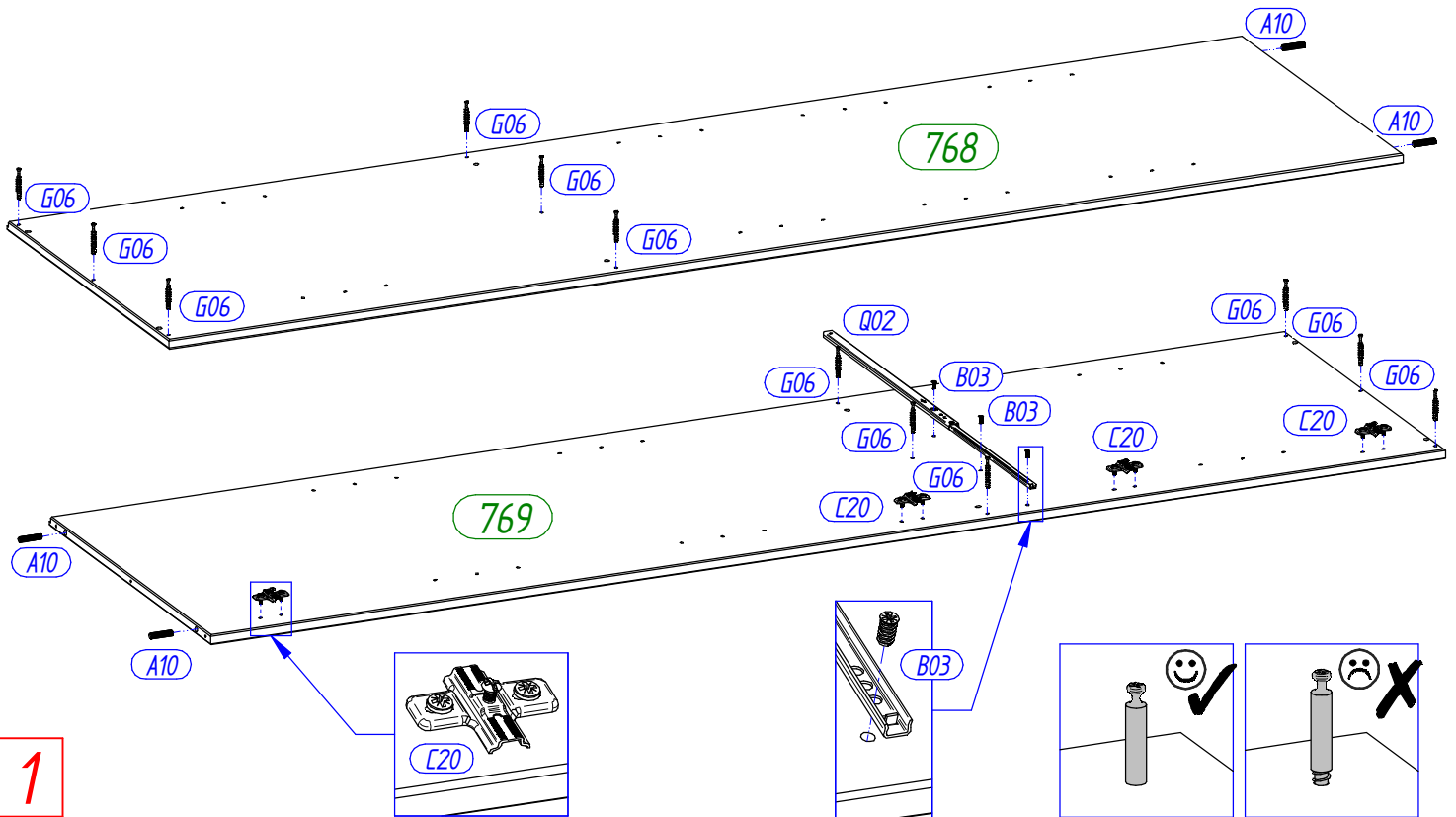

A10	4 x	B03	3 x	G08	6 x	G12	3 x	Q02	1 x
Ø8 x 35		Ø5,8 x 11		M4 / 7,0 x 34		M4 x Ø5 x 14		17 x 430	

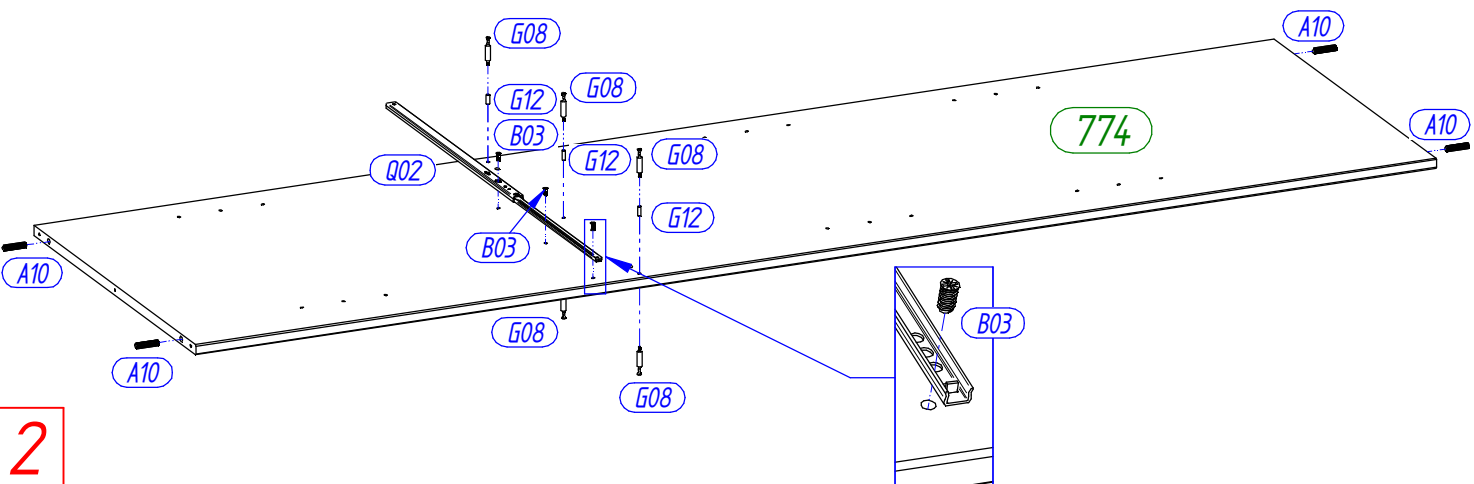

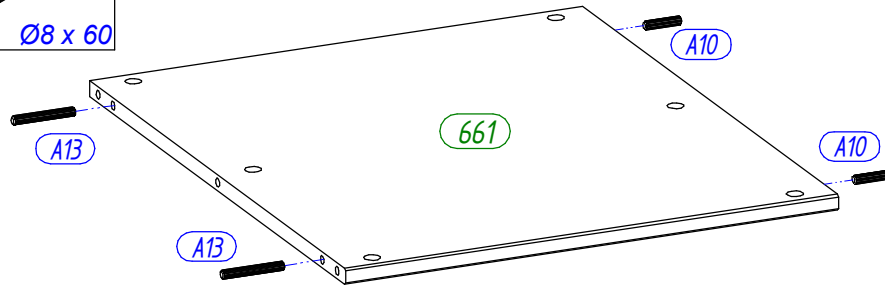
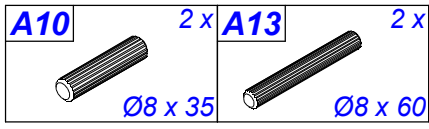

3

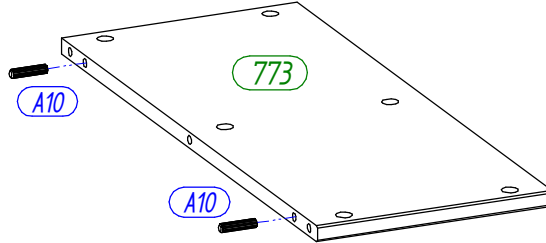
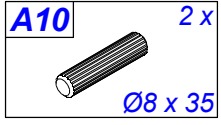

4

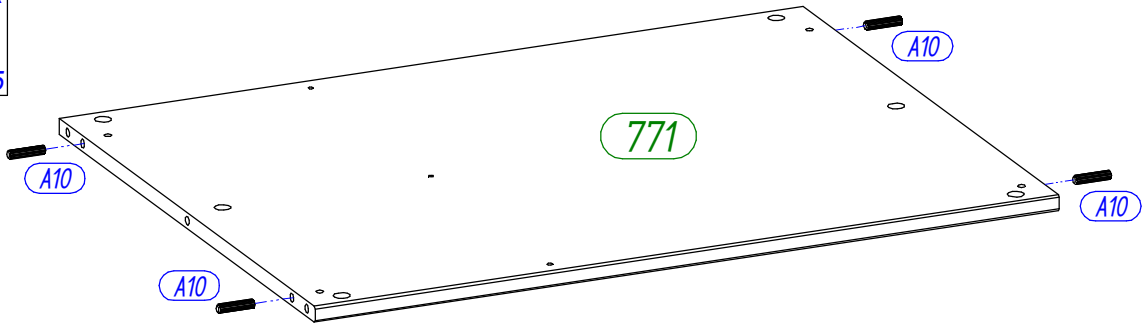
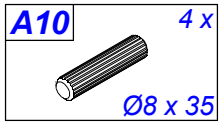

5

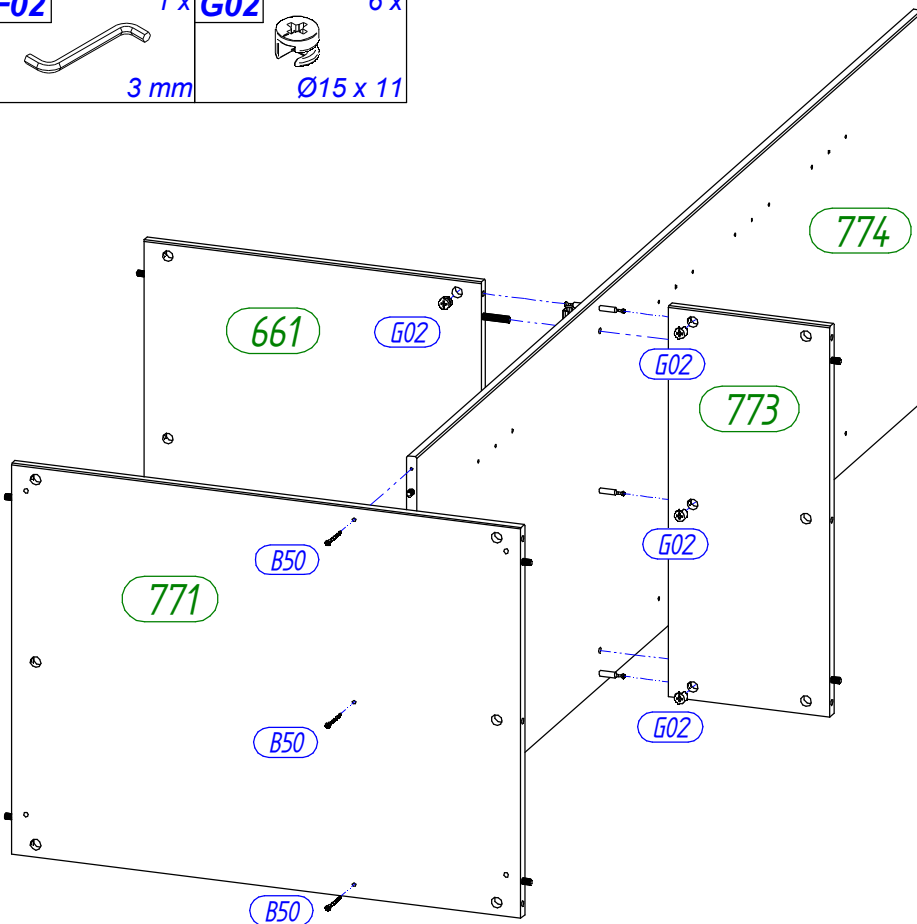
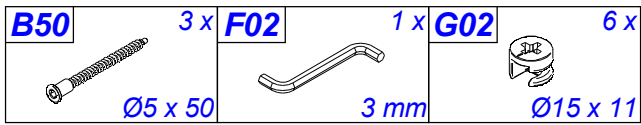

6

G02 12 x

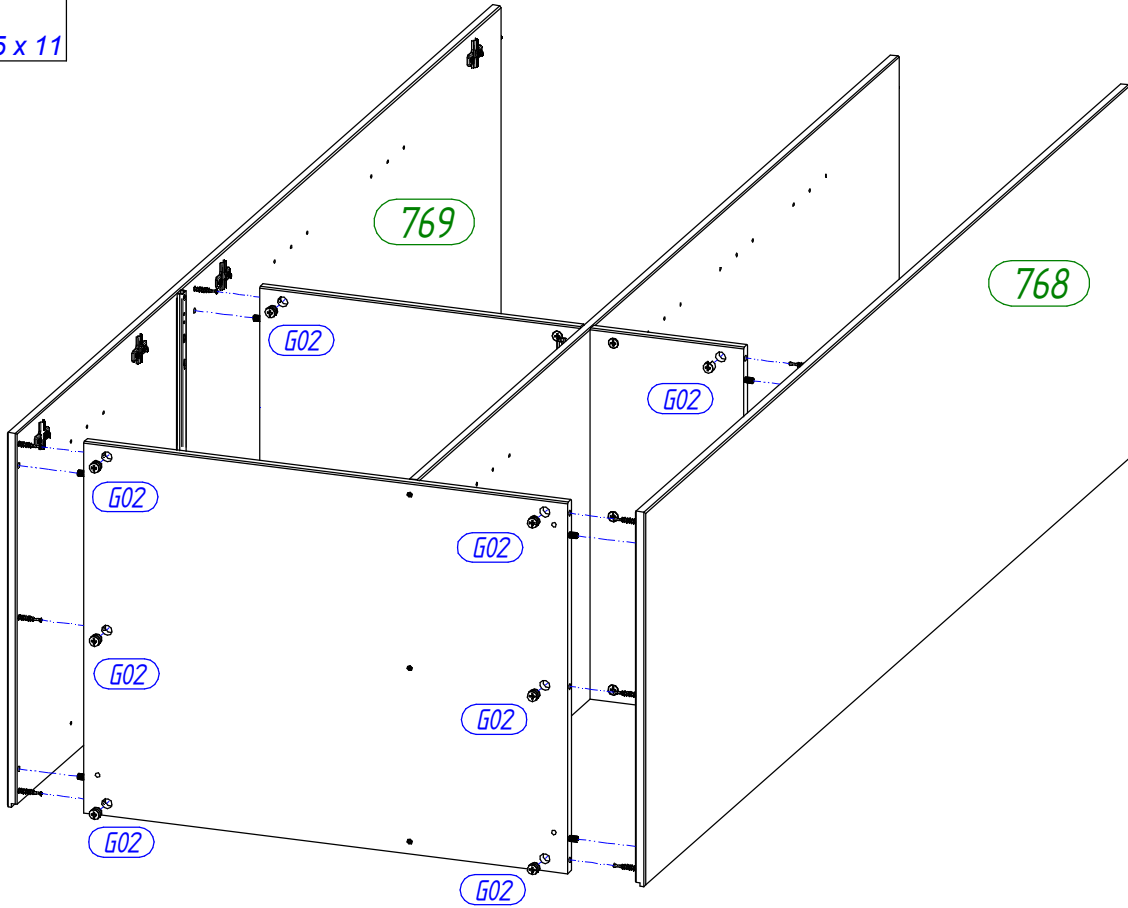
 Ø15 x 11

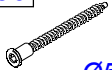
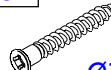
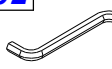
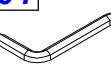

7

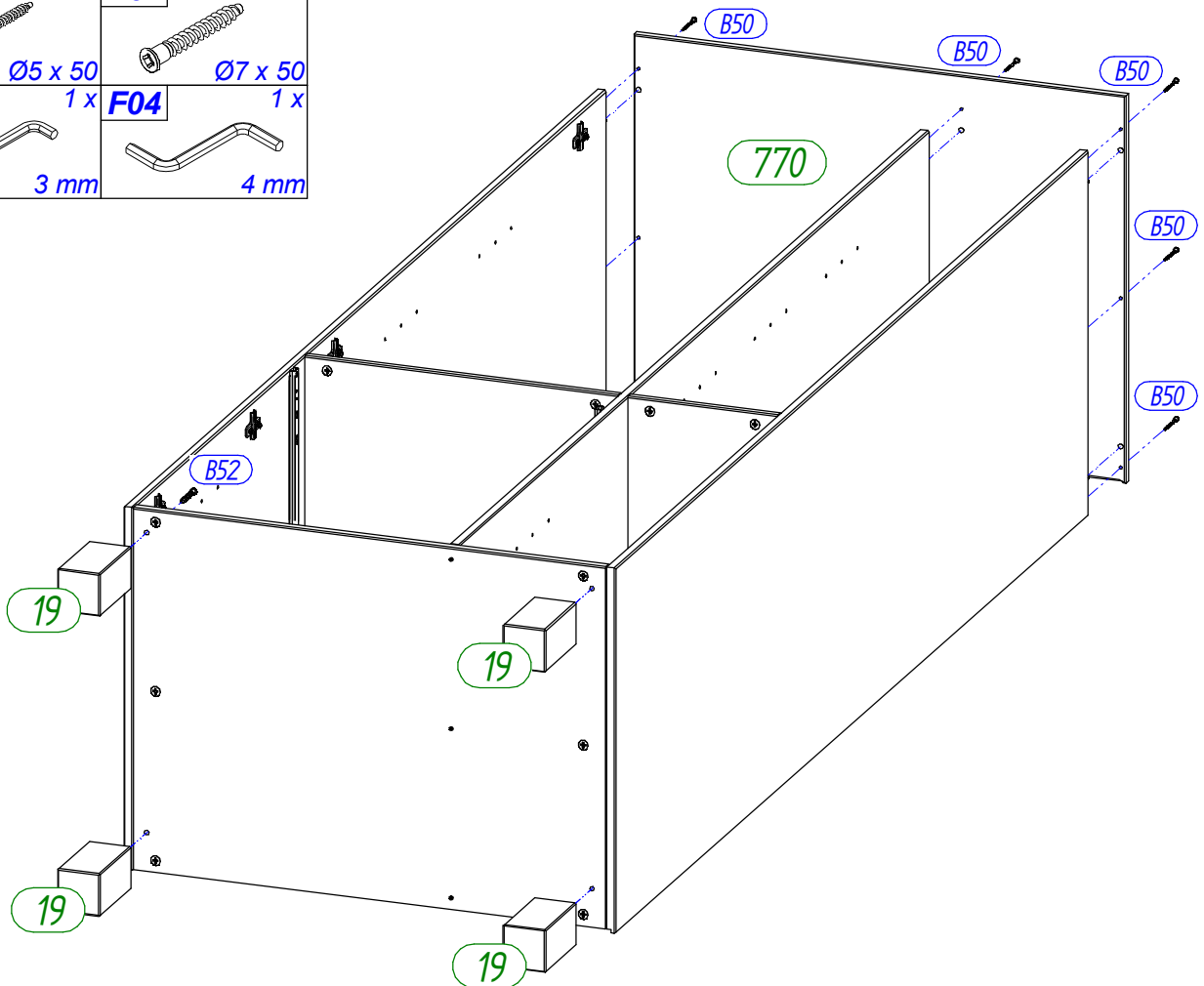
B50 9 x  Ø5 x 50	B52 4 x  Ø7 x 50
F02 1 x  3 mm	F04 1 x  4 mm



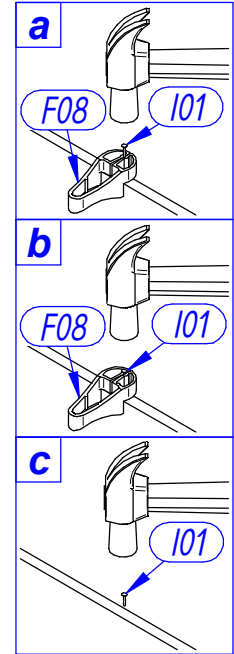
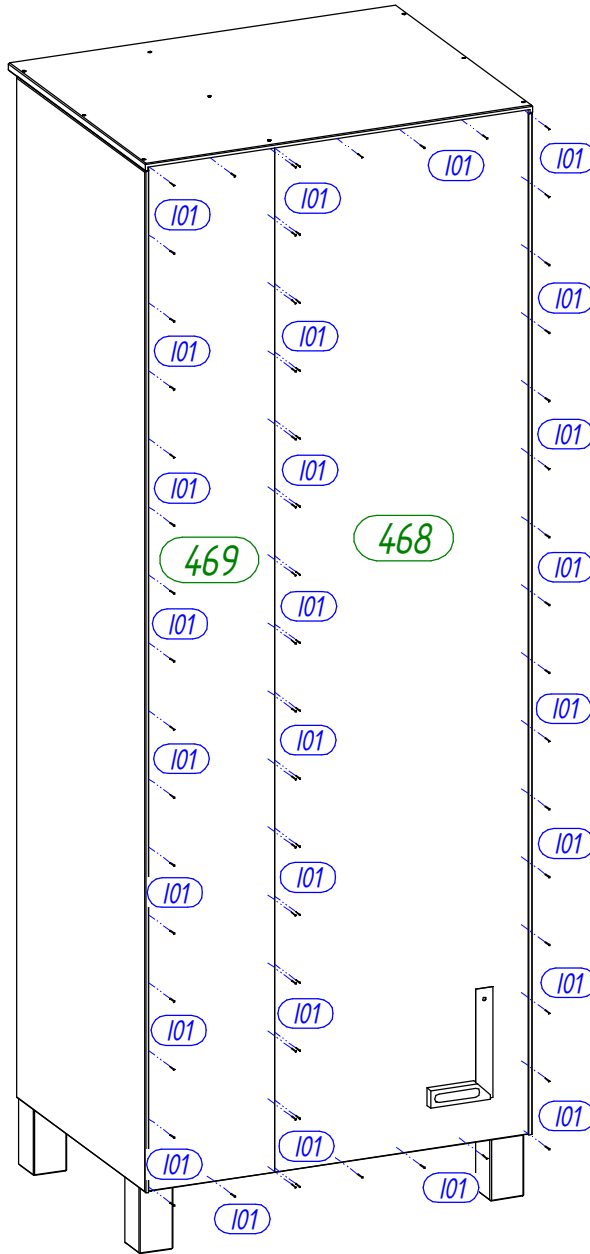
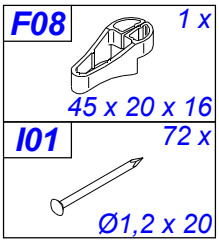

8

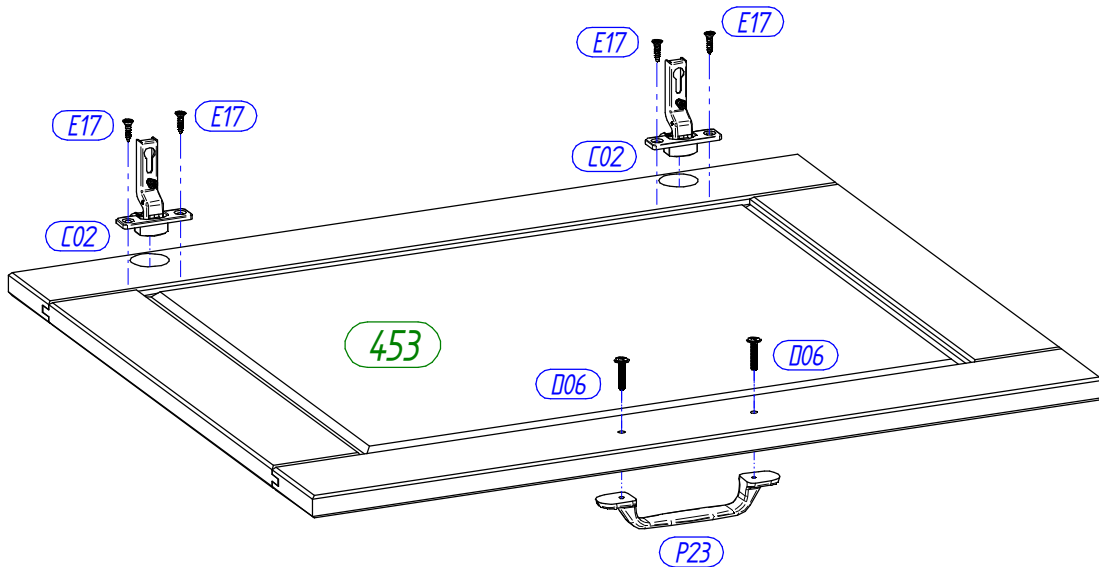
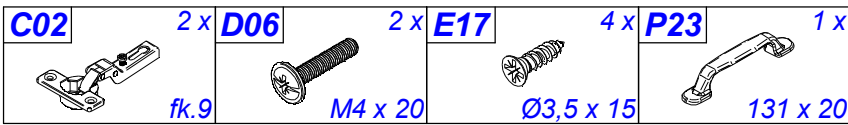

9



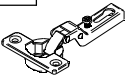

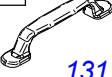

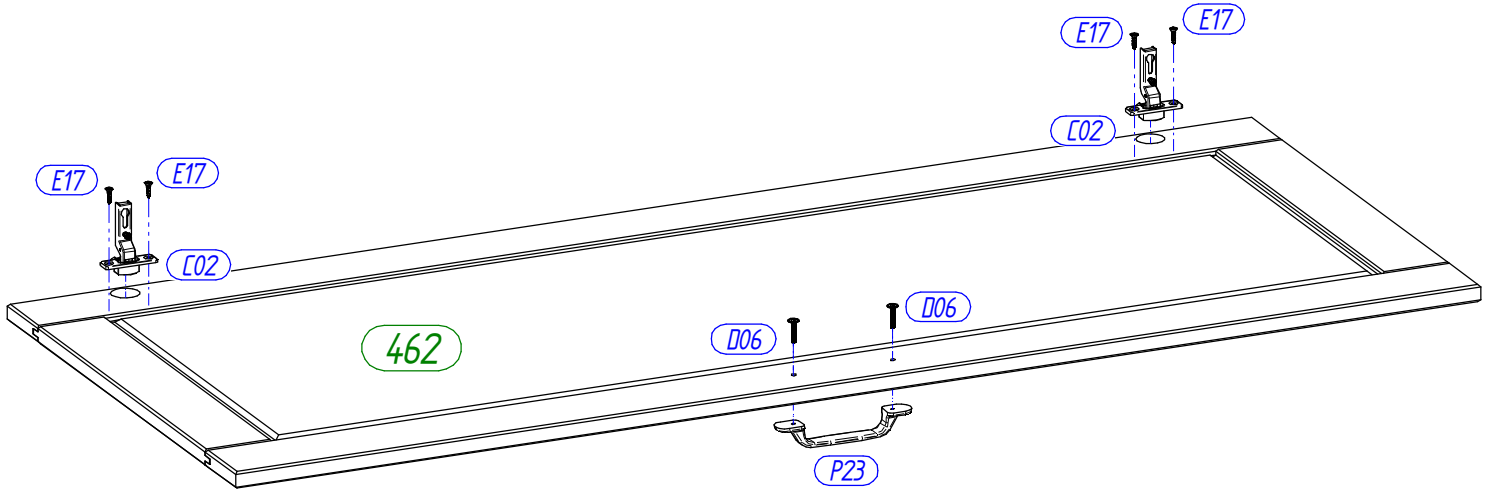

10

C02	2 x	D06	2 x	E17	4 x	P23	1 x
	fk.9		M4 x 20		Ø3,5 x 15		131 x 20

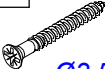

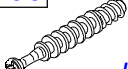
11

A10	2 x	D06	2 x	E22	4 x	G02	2 x	G06	2 x	P23	1 x
	Ø8 x 35		M4 x 20		Ø3,5 x 35		Ø15 x 11		L - 34		131 x 20

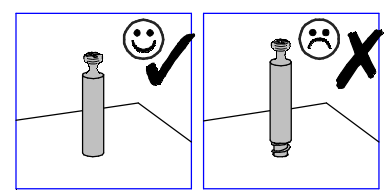
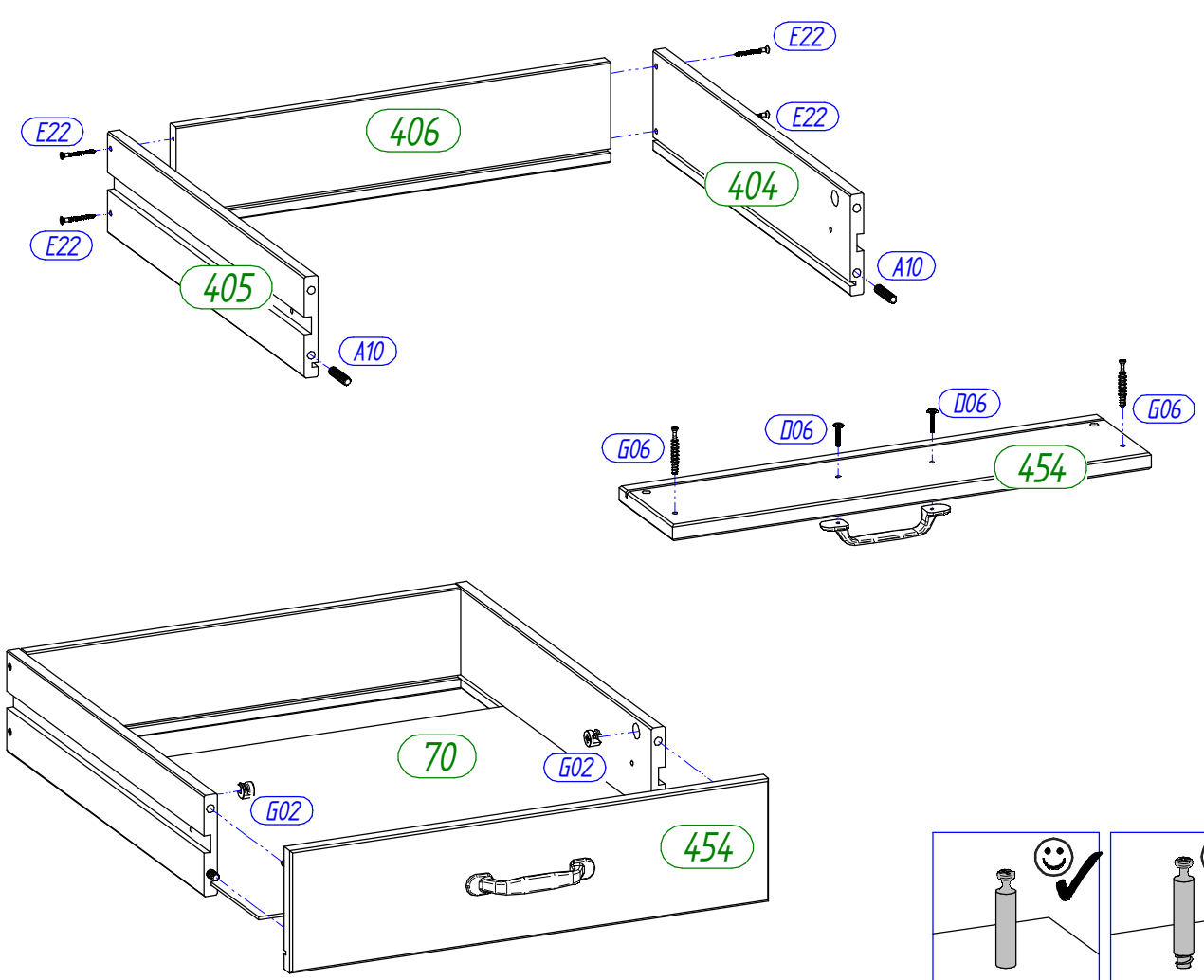

12

Achtung • Attention • Attenzione • Opgelet • Uwaga • Pozor • Figyelem • Atenție • Dikkat • Внимание

(D)	Wandbefestigung dient als Kippschutz – unbedingt anbringen! Bei einigen Wandtypen kann ein Spezialdübel erforderlich sein!
(GB)	The wall fastening serves to prevent tipping – be absolutely sure to mount it! For certain wall types, a special dowel may be necessary!
(NL)	Bevestiging aan de muur dient als kantelbescherming – zeker en vast bevestigen! Bij enkele muurtypen is een speciale plug misschien vereist!
(PL)	Mocowanie do ściany jest jednocześnie zabezpieczeniem przed przewróceniem – koniecznie zamontować! Do niektórych rodzajów ścian konieczne mogą być specjalne wkręty!
(TR)	Duvardaki sabitleme, devrilmeye karşı bir emniyet tedbiridir ve mutlaka monte edilmelidir! Bazı duvar tiplerinde bunun için özel bir dübel gerekli olabilir!
(RU)	Обязательно установите крепление на стене во избежание опрокидывания! Для некоторых типов стен может потребоваться специальный дюбель!
(FR)	La fixation murale sert de protection contre le basculement – à installer impérativement ! Pour certains types de murs il faut des chevilles spéciales !
(IT)	Il fissaggio alla parete serve da protezione anti-ribaltamento – attaccarla assolutamente! Per alcune strutture di parete può essere necessario un tassello speciale!
(CZ)	Montáž na stěnu slouží jako ochrana proti převrnutí – bezpodmínečně umístěte! U některých typů stěn může být zapotřebí speciální hmoždinka!
(SK)	Upevnenie na stenu slúži ako ochrana proti prevráteniu – bezpodmienečne použite! Pre niektoré druhy stien môže byť potrebná špeciálna hmoždinka!
(HU)	A terméket a falhoz kel rögzíténi, különben az felborulhat! Egyes faltípusoknál speciális tiplít kell használni!
(RO)	Sistemul de fixare la perete servește ca protecție la răsturnarede montat obligatoriu! Pentru unele tipuri de pereți este posibil să fie necesar un diblu special!

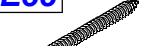
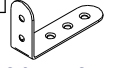
E17	2 x	E38	1 x	K03	1 x
					
Ø3,5 x 15		Ø4,0 x 60		20 x 42 x 70	

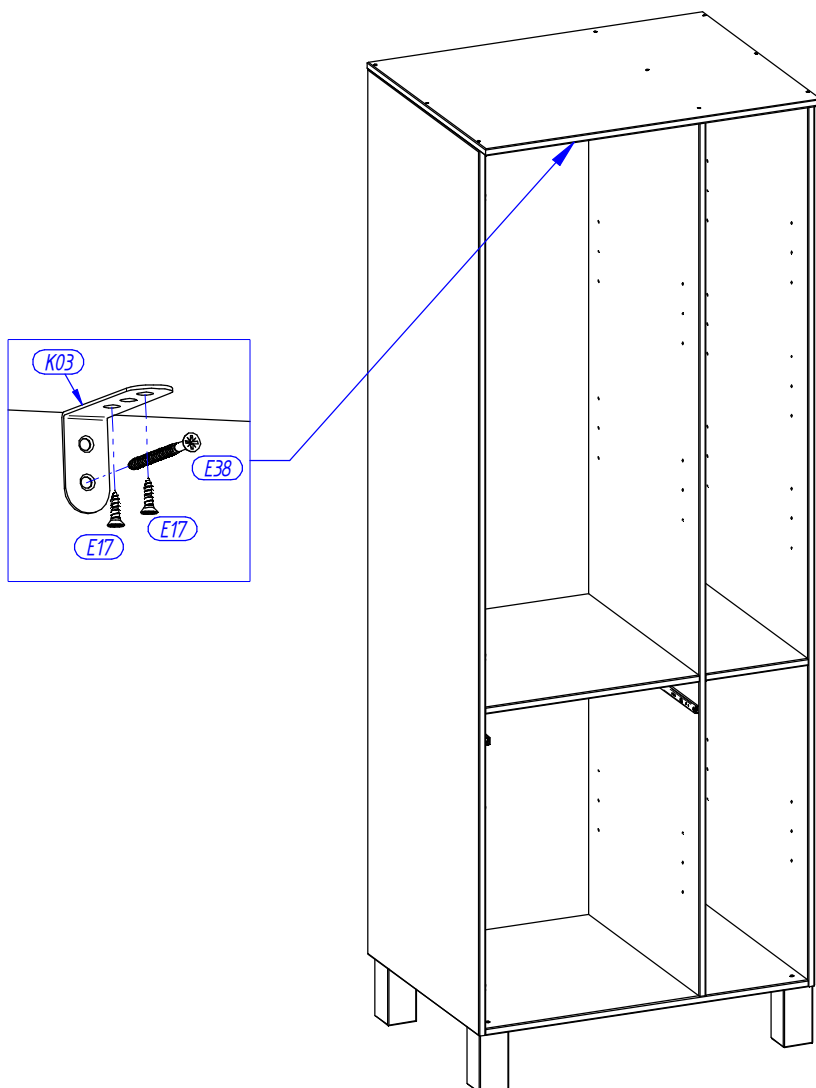

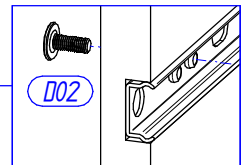
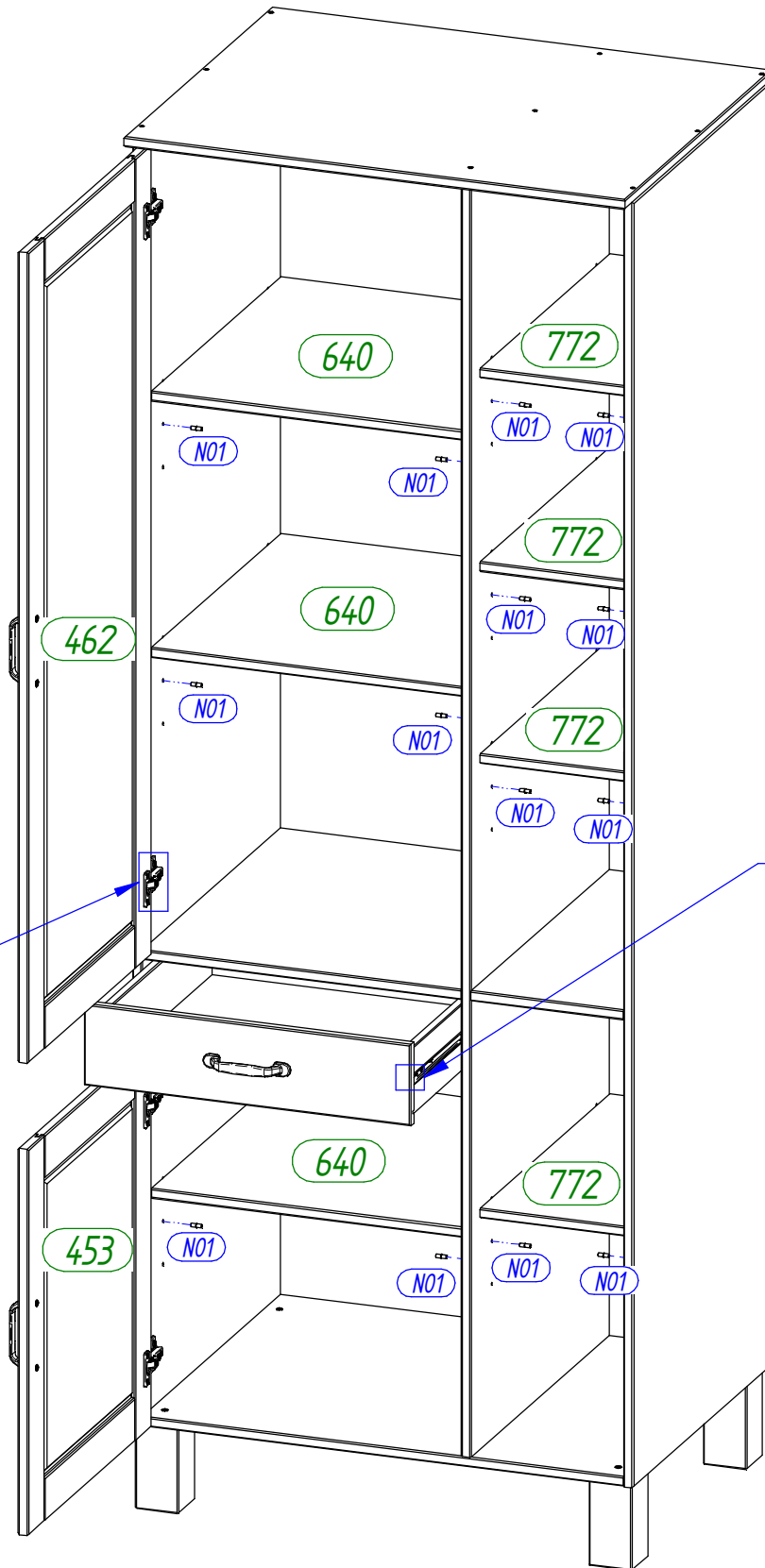
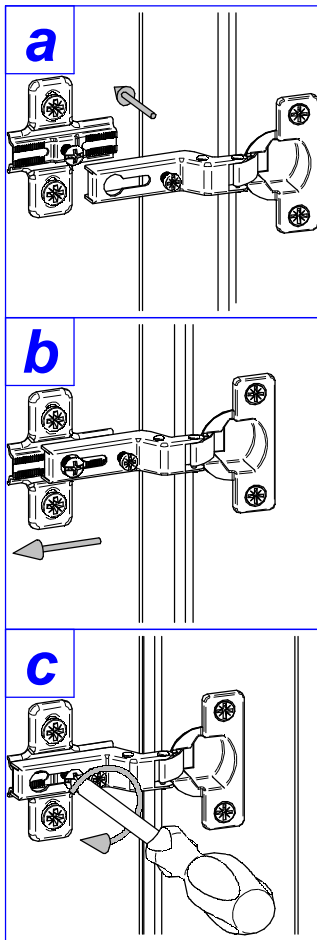
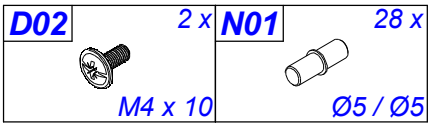

D	Türen einstellen (Scharniere justieren)
GB	Adjusting the doors (adjusting the hinges)
NL	Deuren instellen (scharnieren afstellen)
PL	Nastawić drzwi (wyrównać zawiasy)
TR	Kapıların ayarlanması (menteşelerin seviye ayarı)
RU	Регулировка дверей (регулировка шарнира)
FR	Régler les portes (ajuster les charnières)
IT	Sistemare le porte (regolare le cerniere)
CZ	Vyrovnejte dvířka (seřídte závěsy)
SK	Nastavenie dverí (nastavenie závesov)
HU	Állítsa be az ajtókat (állítsa be a zsanérokat)
RO	Reglare ușii (ajustare balamale)

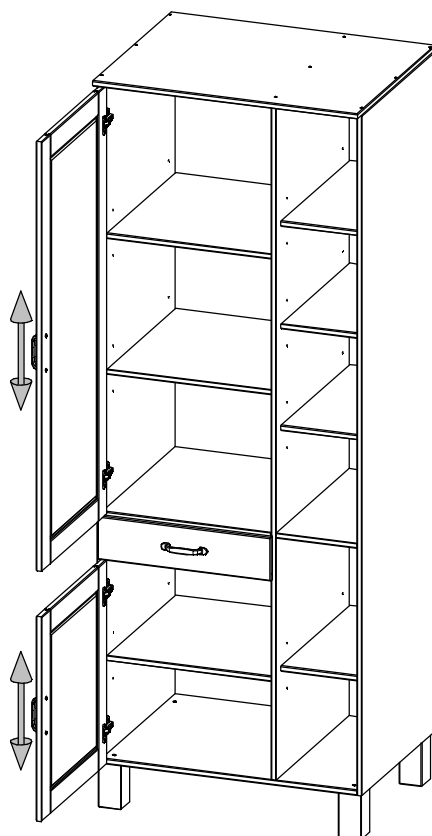
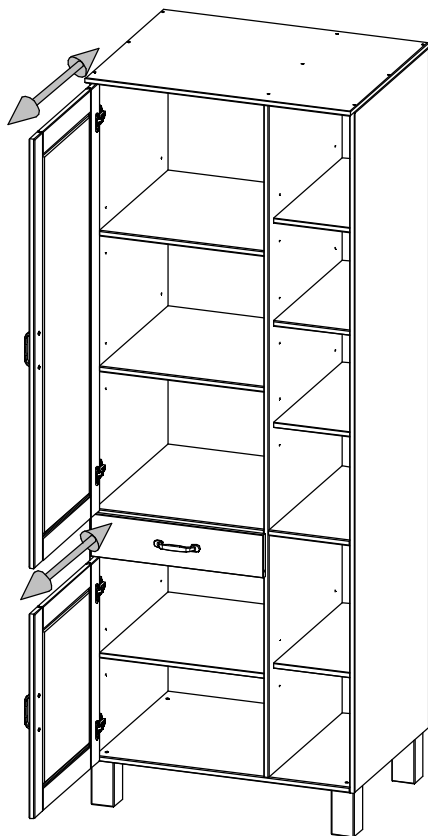
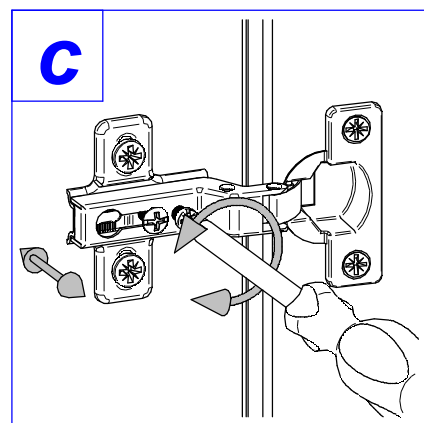
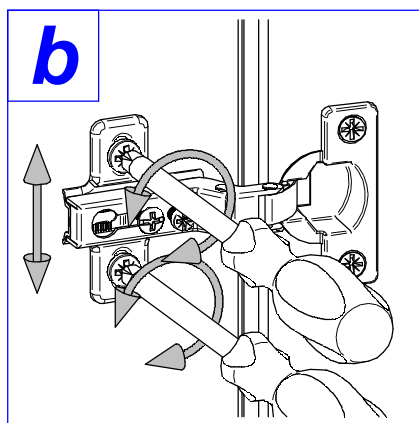
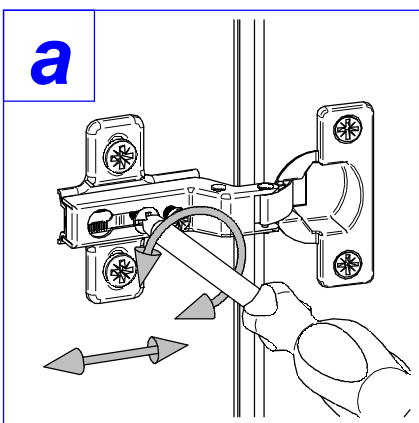

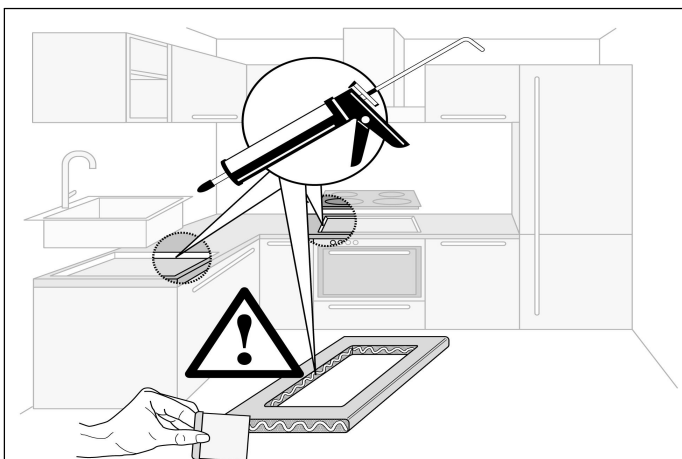
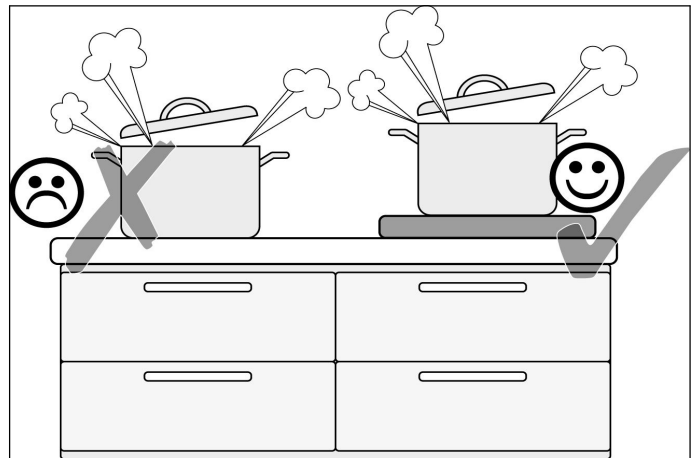
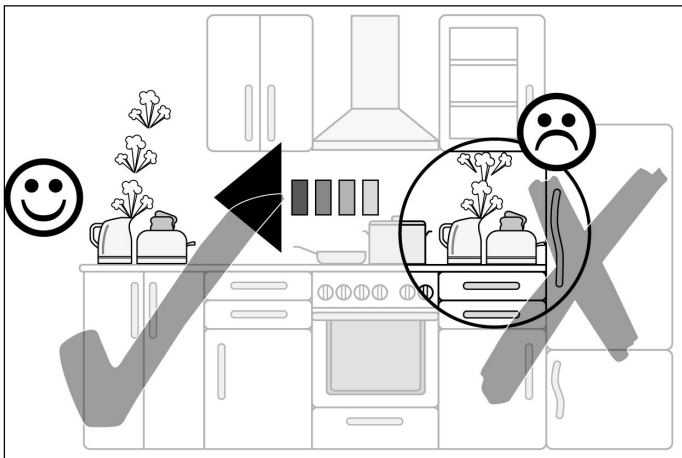
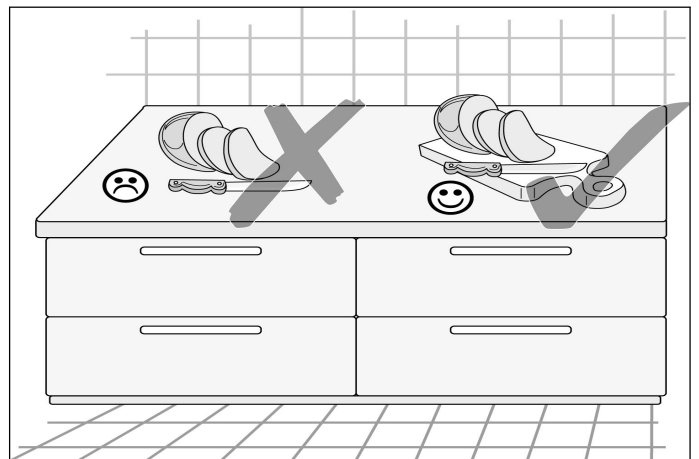
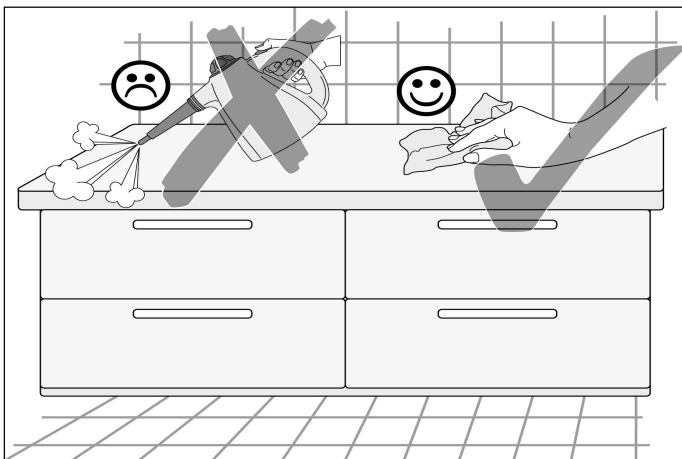
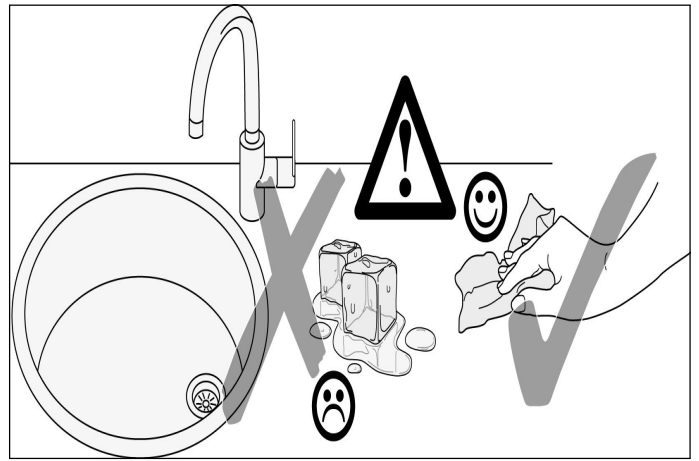
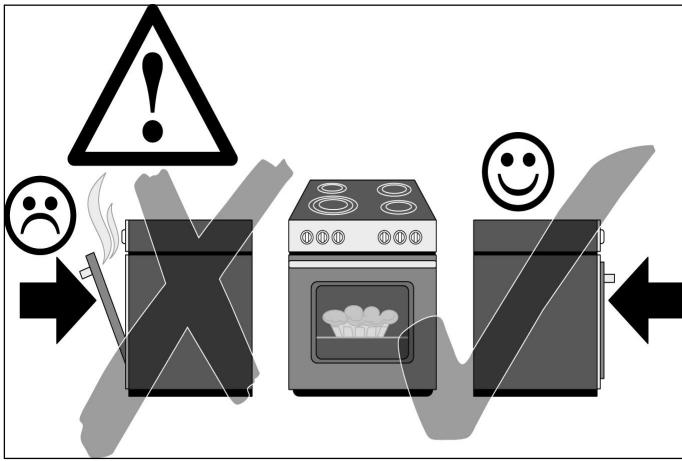

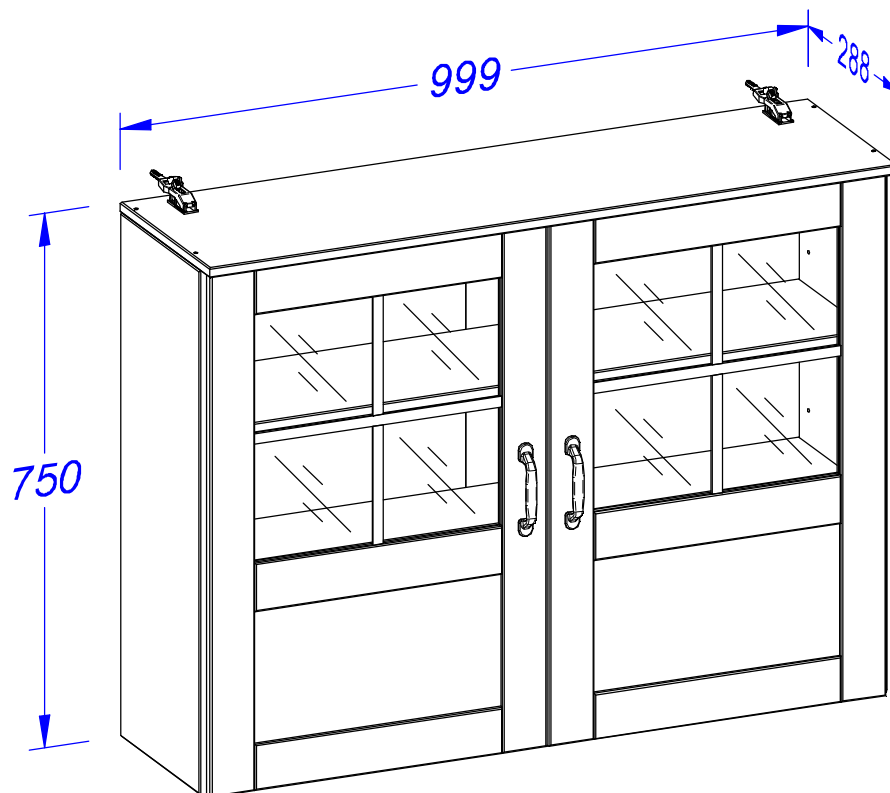

(D) *Montageanleitung*

(NL) *Handleiding voor de montage*

(TR) *Montaj talimatı*

(FR) *Notice de montage*

(CZ) *Montážní návod*

(HU) *Szerelési útmutató*

(GB) *Assembly instructions*

(PL) *Instrukcja montażu*

(RU) *Инструкция по монтажу*

(IT) *Istruzioni di montaggio*

(SK) *Návod na montáž*

(RO) *Instrucțiuni de montaj*

Name • Nom • Nome • Naam • Nazwa • Jméno •
Názov • Név • Denumire • Isim • Название

Nr. • No. • N° • Номер • Č • Sz

Typ • Type • Tip • Tipus • Tipo • Тип

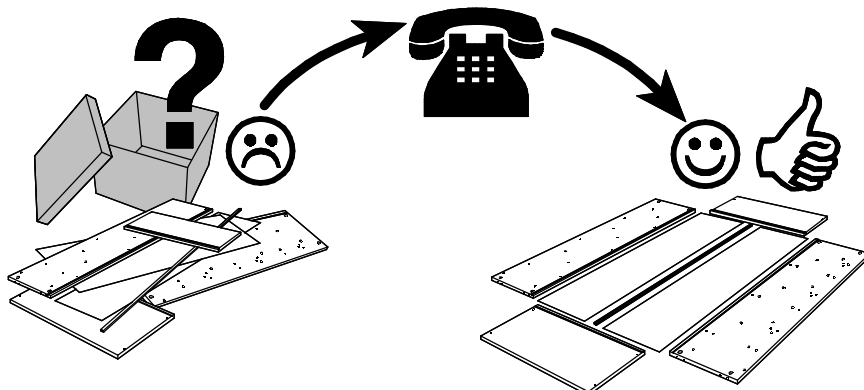
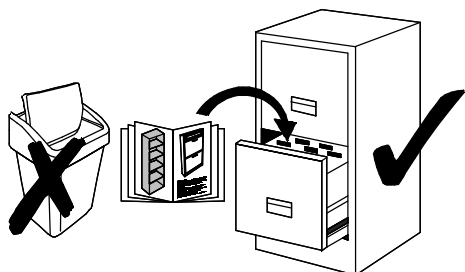

A	8 x	C	4 x	Ce	4 x	Dd	4 x	Ea	8 x	Fb	1 x
Ø8 x 35		2 mm		fk.9		M4 x 20		Ø3,5 x 15		3 mm	
G	4 x	Ga	4 x	Hc	4 x	I	50 x	lb	1 x	Lk	1 x
L - 34		Ø15 x 11		Ø5 x 50		Ø1,2 x 20		45 x 20 x 16		2 set	
N	8 x	No	2 x								
Ø5 / Ø5		131 x 20									

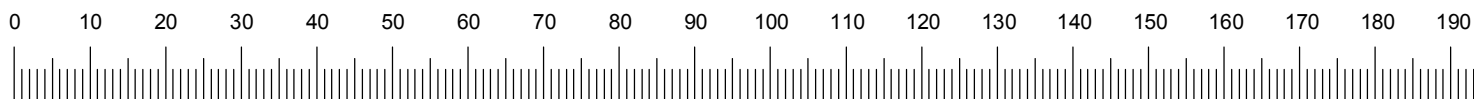
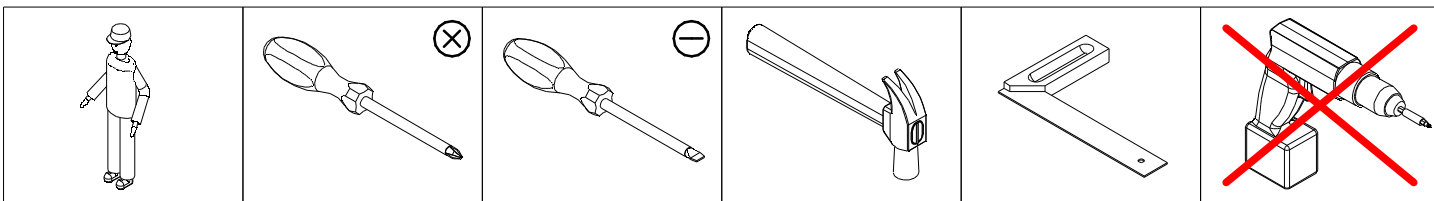

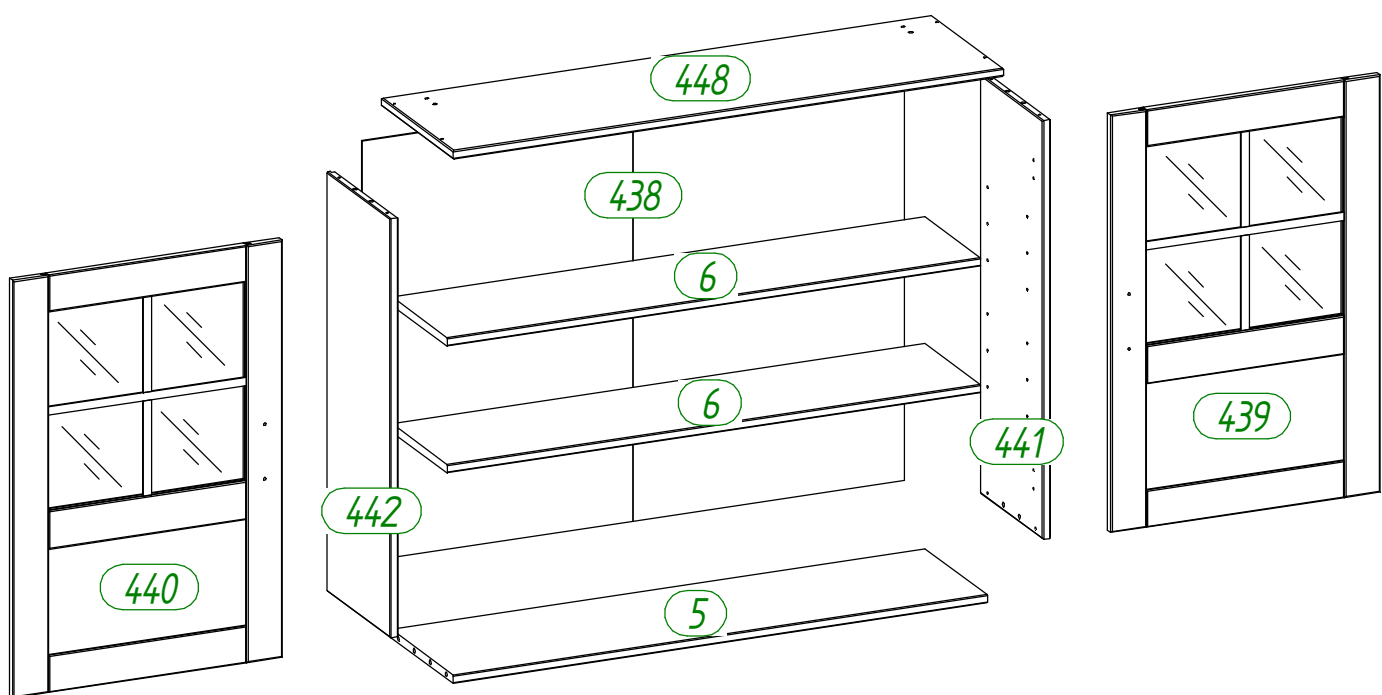

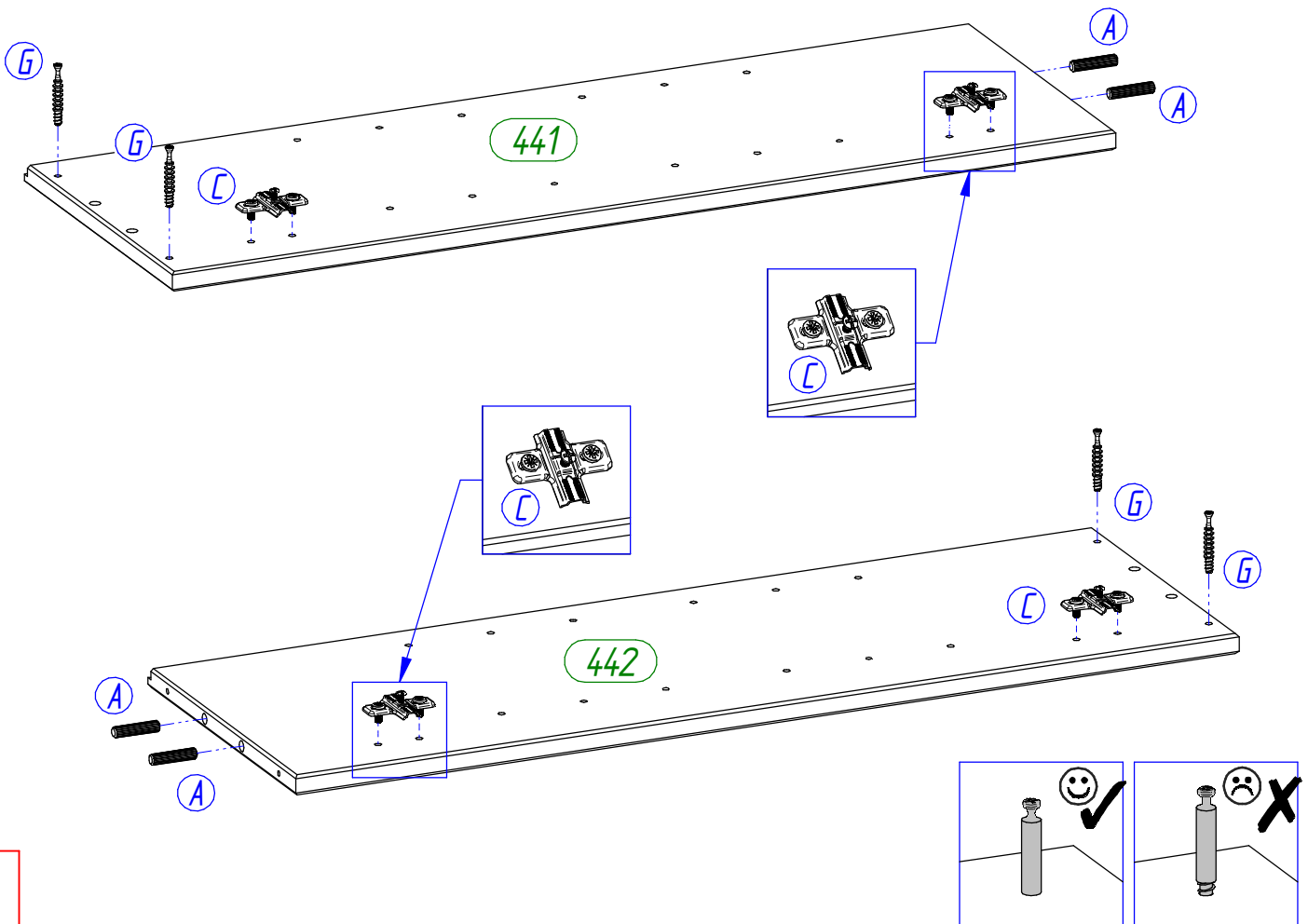
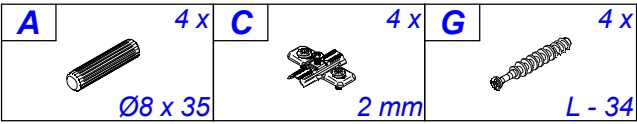
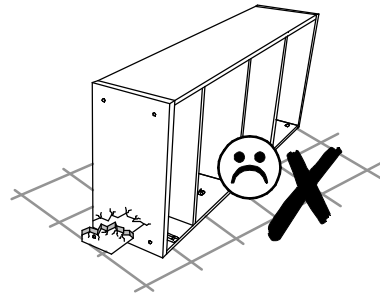
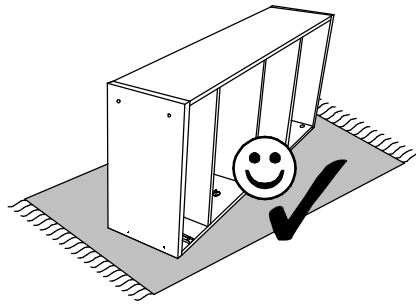

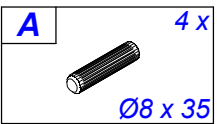

1



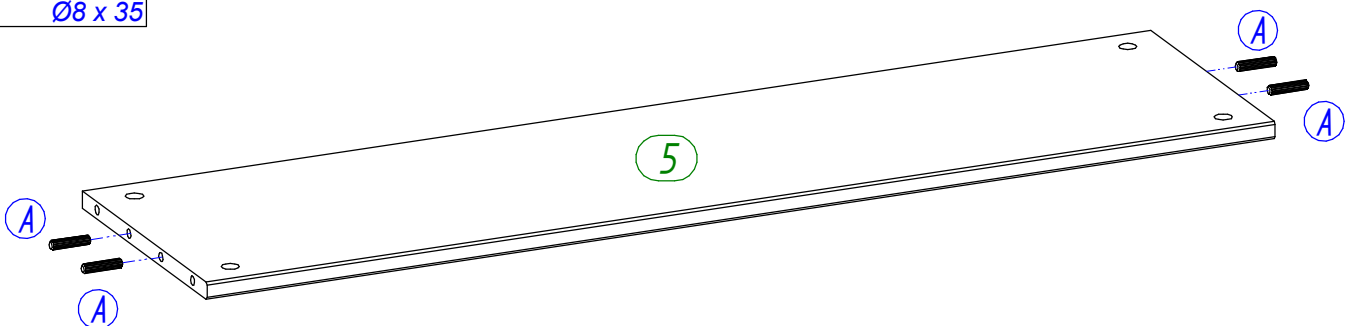

2

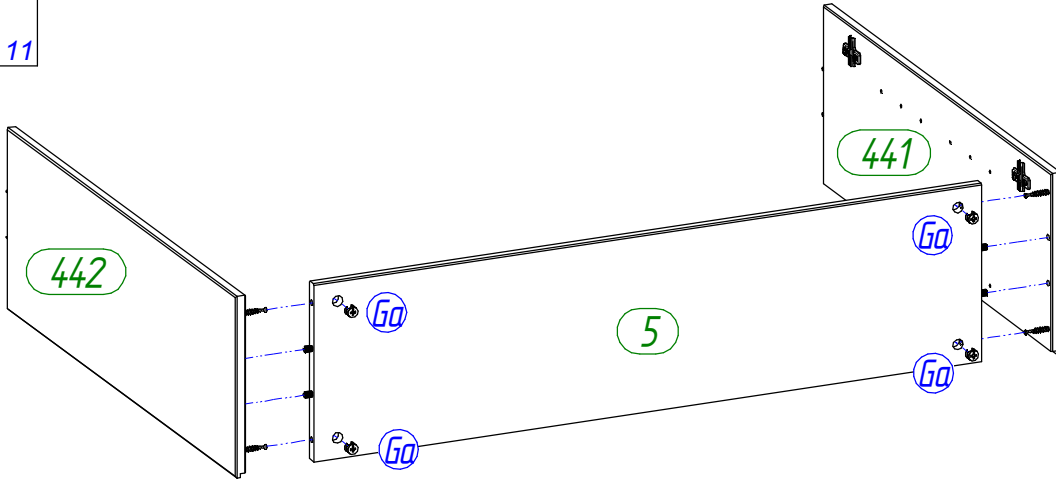

Ga 4 x

 Ø15 x 11



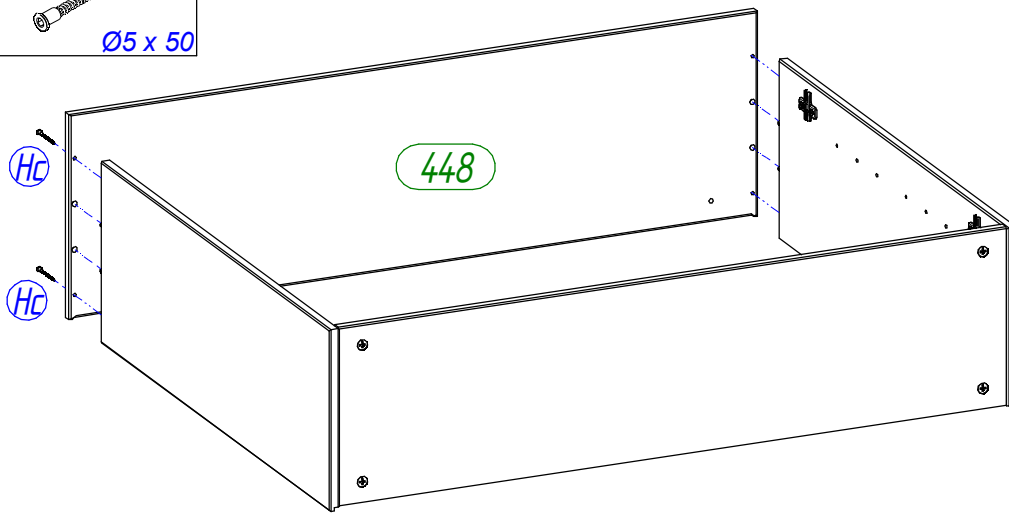

3

Fb 1 x **Hc** 4 x

 3 mm 
 Ø5 x 50

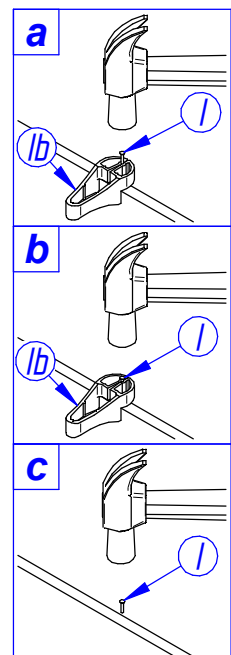
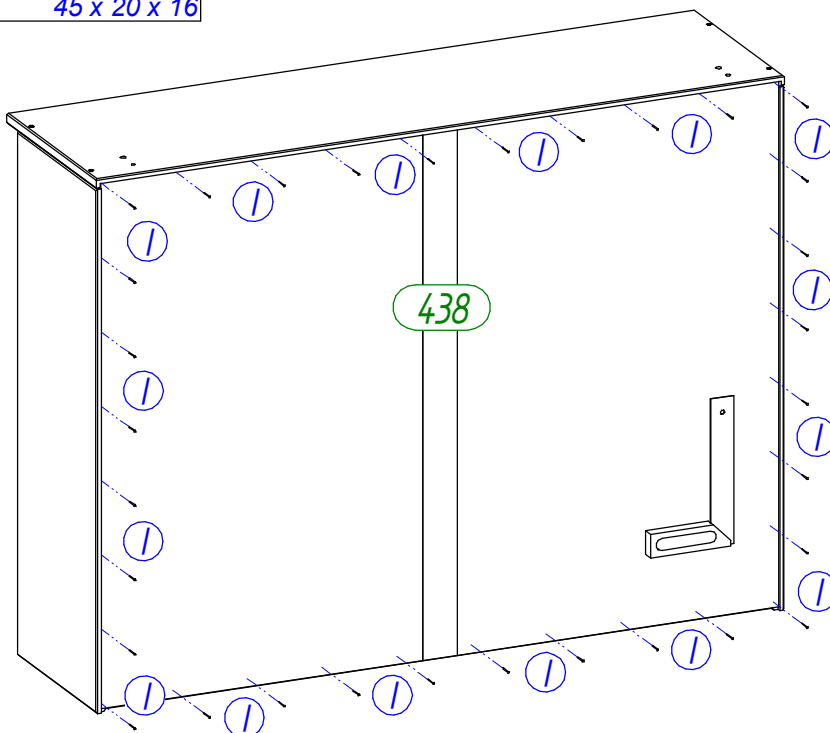

4

I 32 x **lb** 1 x

 Ø1,2 x 20 
 45 x 20 x 16

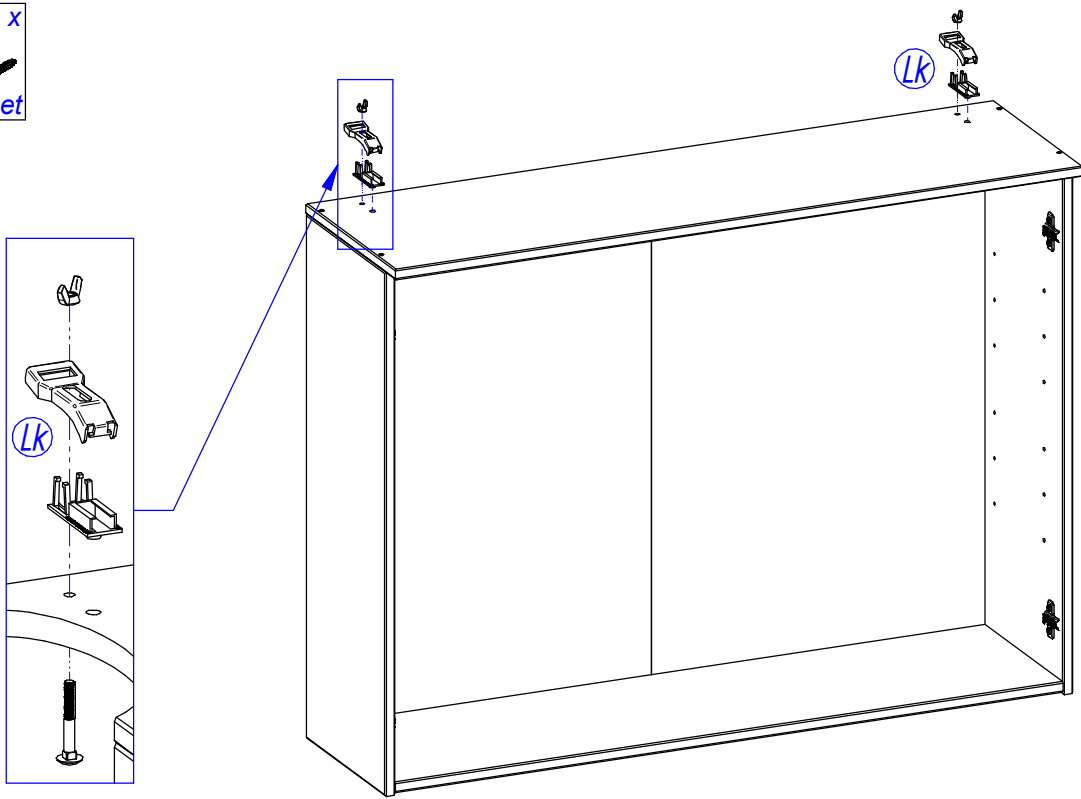
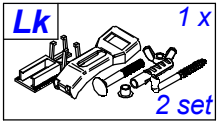

5

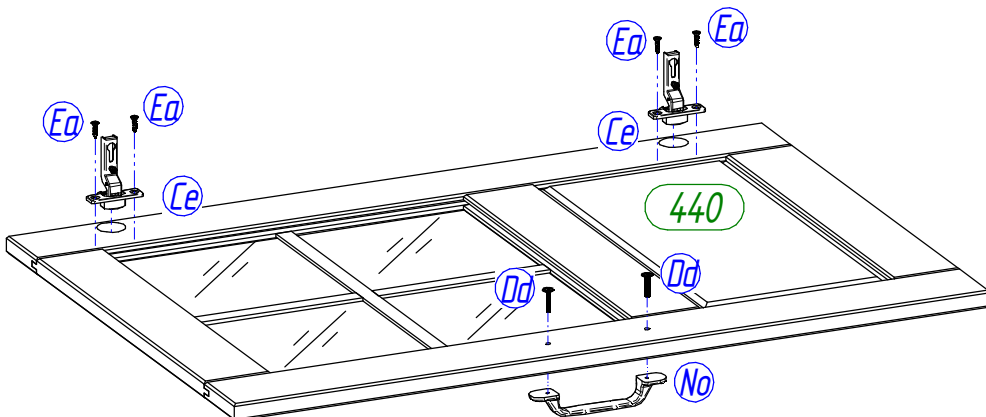
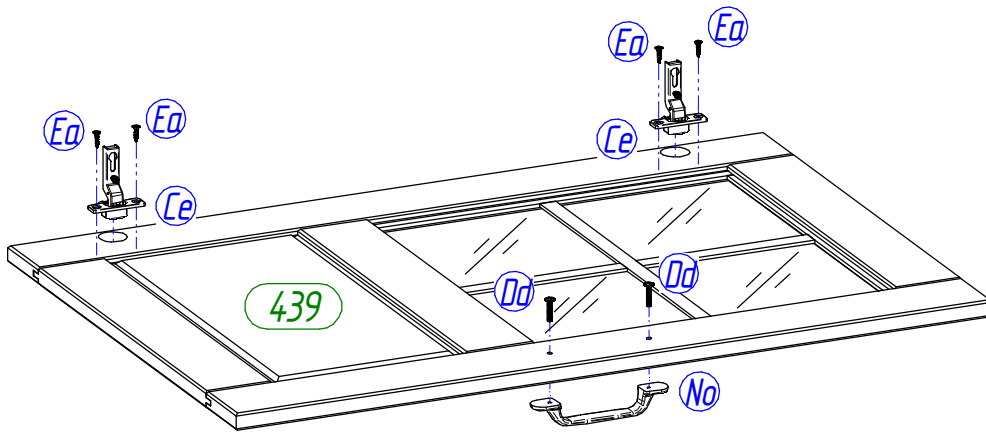
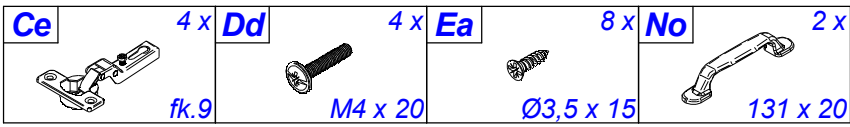

6



7

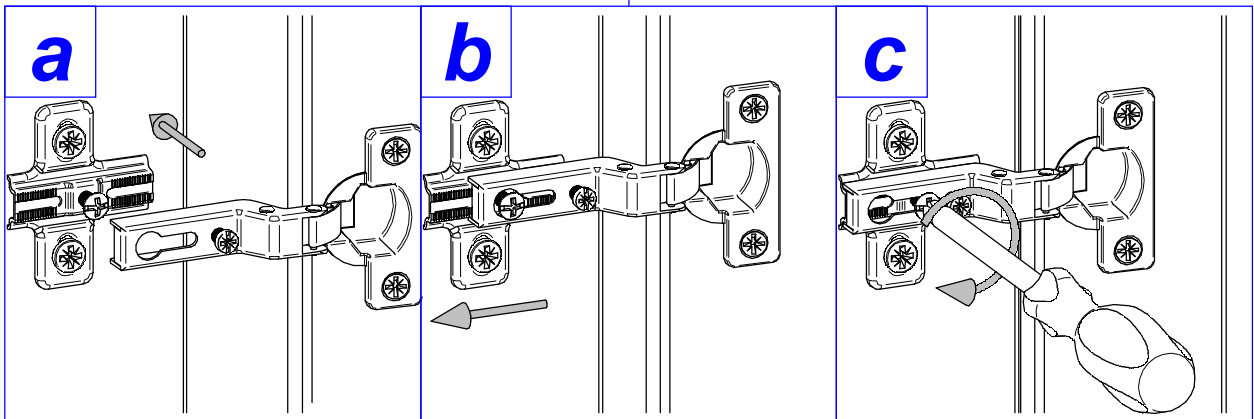
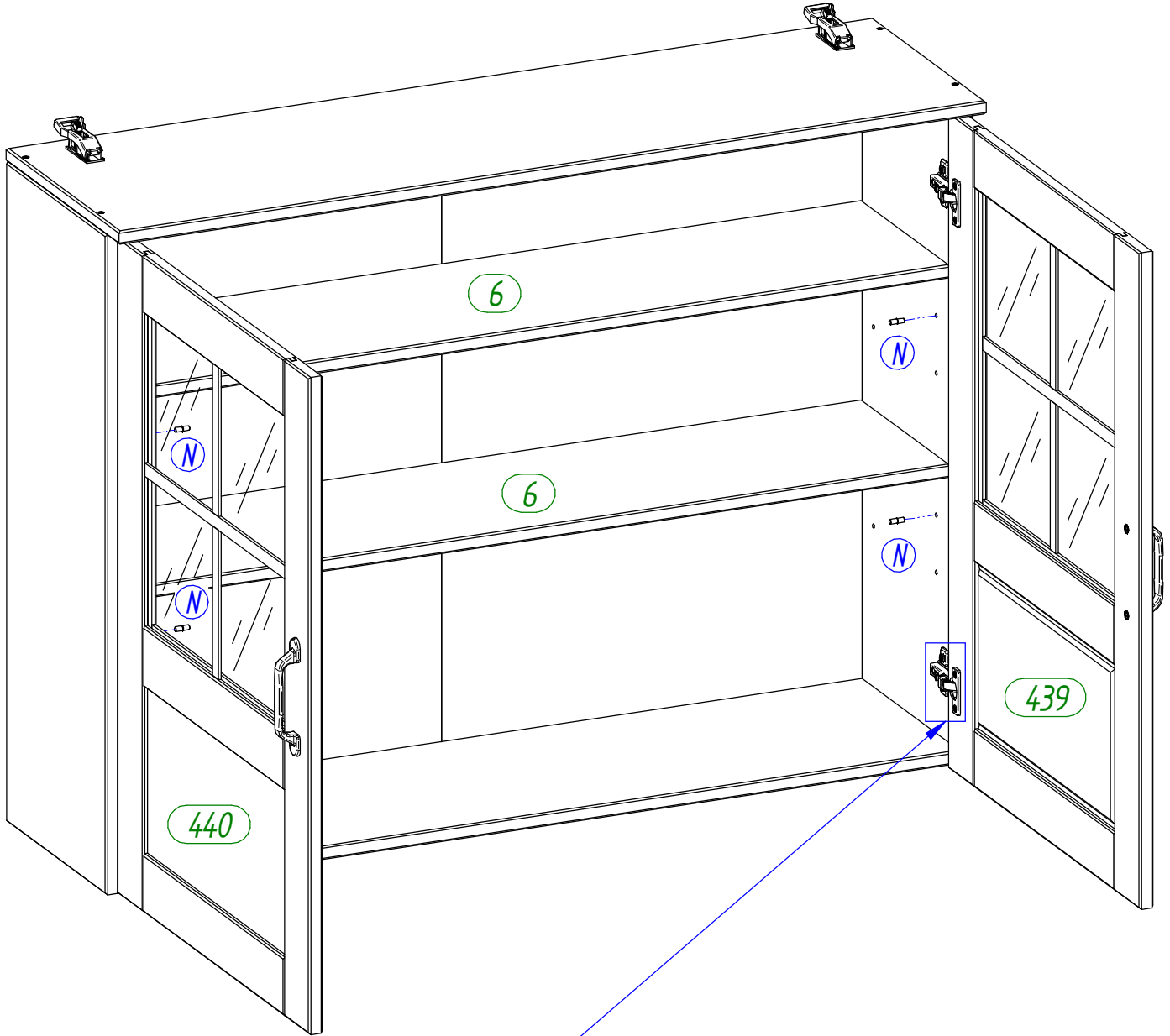
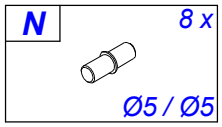

8

(D)	Bei einigen Wandtypen kann ein Spezialdübel erforderlich sein!
(GB)	For certain wall types, a special dowel may be necessary!
(NL)	Bij enkele muurtypes is een speciale plug misschien vereist!
(PL)	Do niektórych rodzajów ścian konieczne mogą być specjalne wkręty!
(TR)	Bazı duvar tiplerinde bunun için özel bir dübel gerekli olabilir!
(RU)	Для некоторых типов стен может потребоваться специальный дюбель!
(FR)	Pour certains types de murs il faut des chevilles spéciales !
(IT)	Per alcune strutture di parete può essere necessario un tassello speciale!
(CZ)	U některých typů stěn může být zapotřebí speciální hmoždinka!
(SK)	Pre niektoré druhy stien môže byť potrebná špeciálna hmoždinka!
(HU)	Egyes faltípusoknál speciális tiplít kell használni!
(RO)	Pentru unele tipuri de pereți este posibil să fie necesar un diblu special!

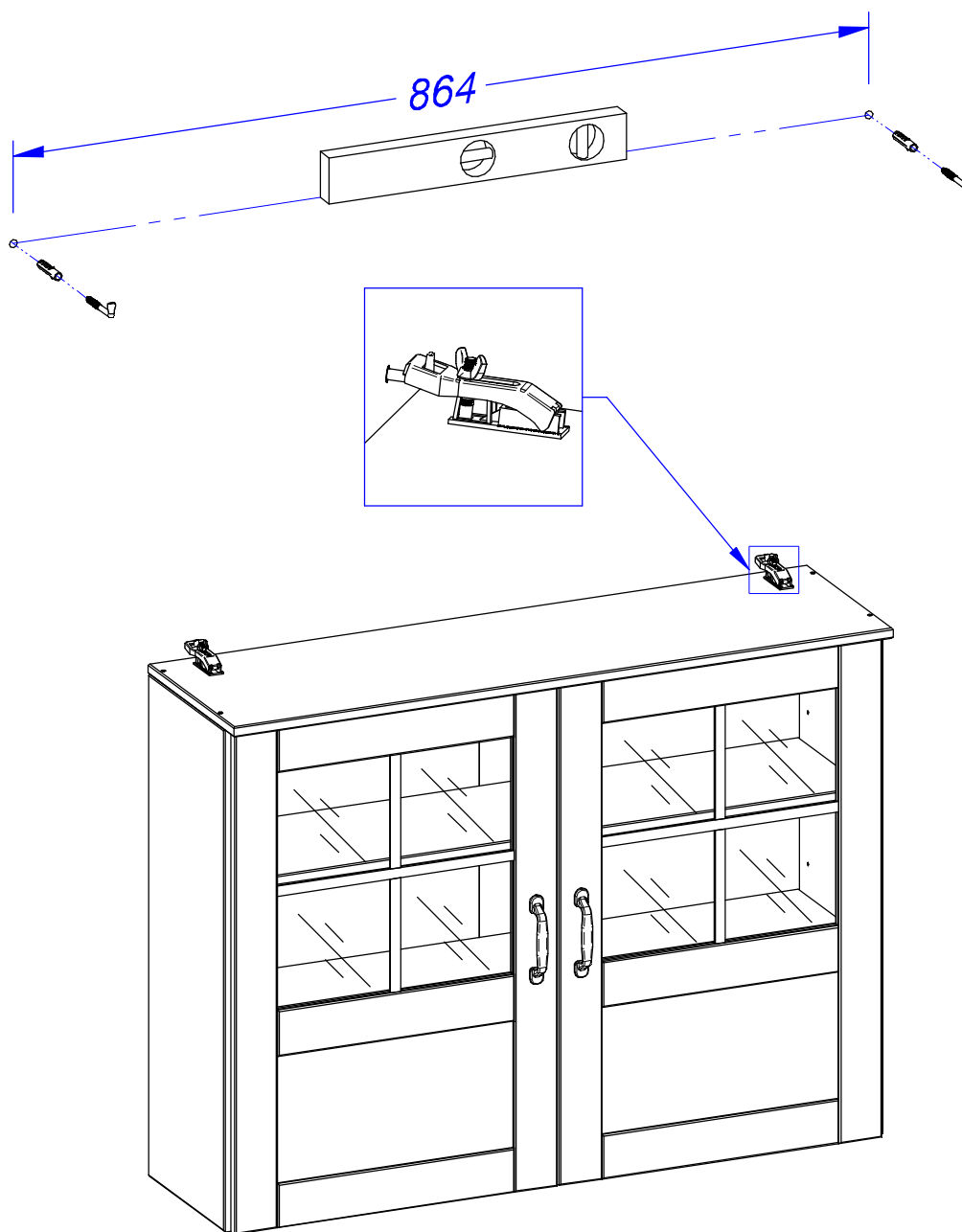

D	Türen einstellen (Scharniere justieren)
GB	Adjusting the doors (adjusting the hinges)
NL	Deuren instellen (scharnieren afstellen)
PL	Nastawić drzwi (wyrównać zawiasy)
TR	Kapıların ayarlanması (menteşelerin seviye ayarı)
RU	Регулировка дверей (регулировка шарнира)
FR	Régler les portes (ajuster les charnières)
IT	Sistemare le porte (regolare le cerniere)
CZ	Vyrovnejte dvířka (seřídte závěsy)
SK	Nastavenie dverí (nastavenie závesov)
HU	Állítsa be az ajtókat (állítsa be a zsanérokat)
RO	Reglare ușii (ajustare balamale)

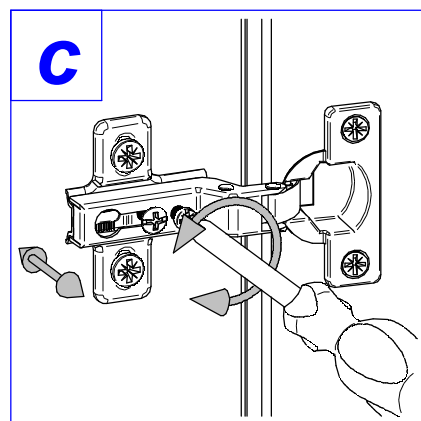
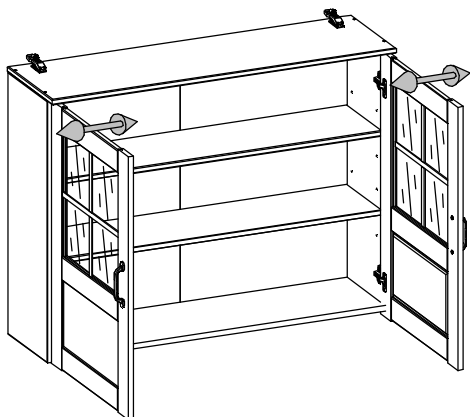
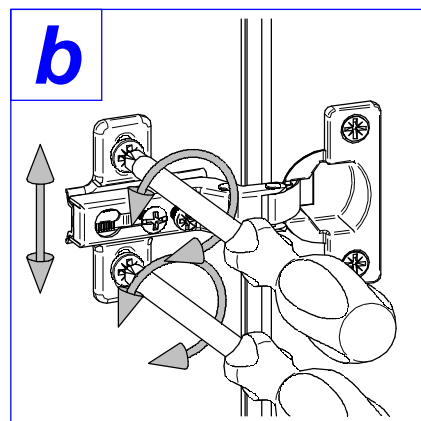
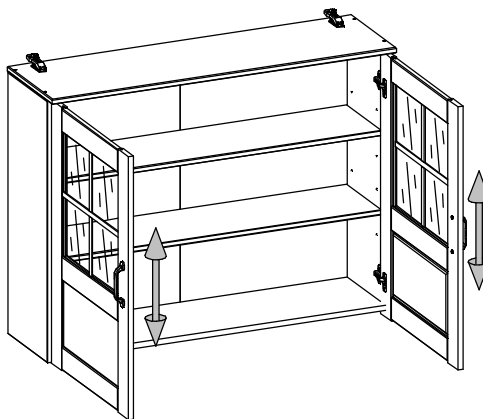
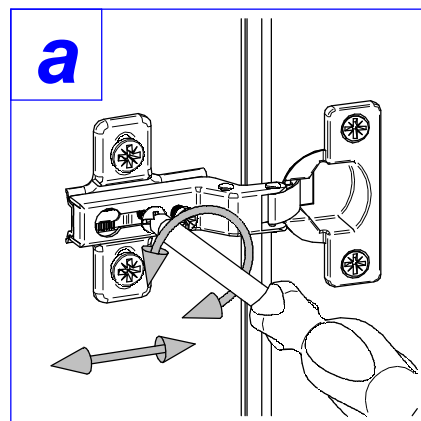
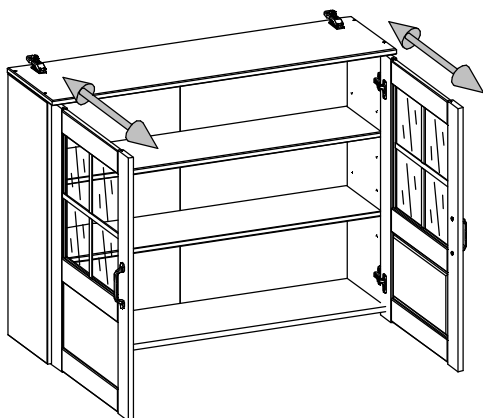

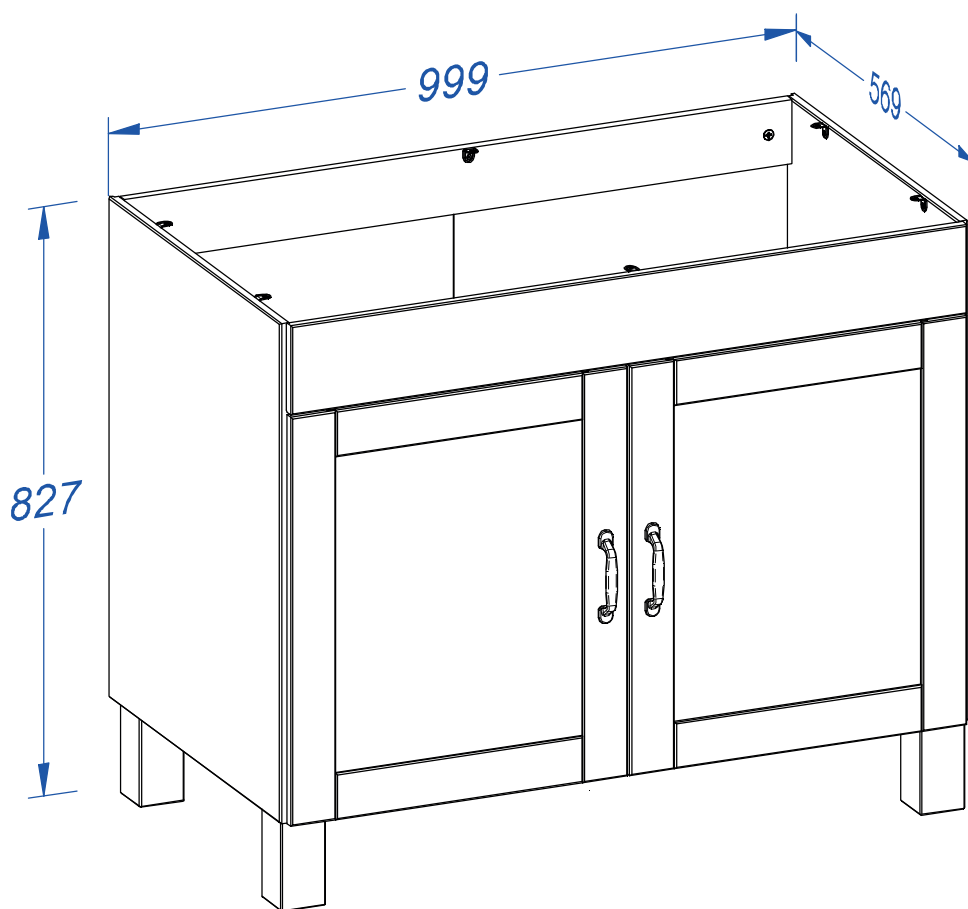

(D) *Montageanleitung*

(NL) *Handleiding voor de montage*

(TR) *Montaj talimatı*

(FR) *Notice de montage*

(CZ) *Montážní návod*

(HU) *Szerelési útmutató*

(GB) *Assembly instructions*

(PL) *Instrukcja montażu*

(RU) *Инструкция по монтажу*

(IT) *Istruzioni di montaggio*

(SK) *Návod na montáž*

(RO) *Instrucțiuni de montaj*



Name • Nom • Nome • Naam • Nazwa • Jméno •
 Nàzov • Név • Denumire • Isim • Название

Nr. • No. • N° • Номер • Č • Sz

Typ • Type • Tip • Tipus • Tipo • Тип

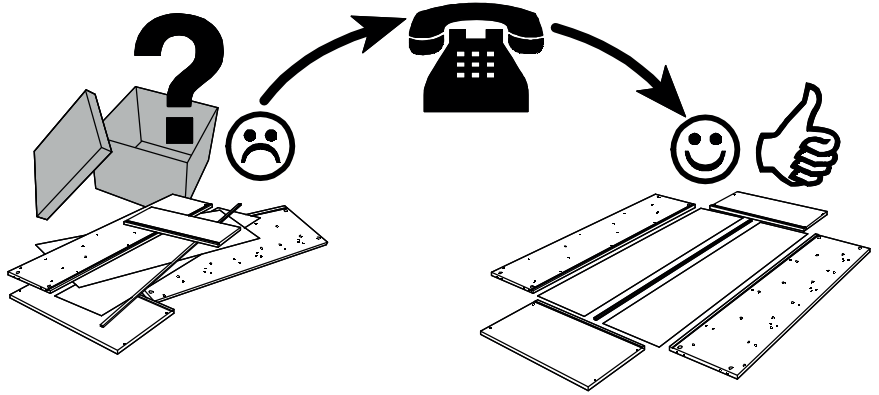
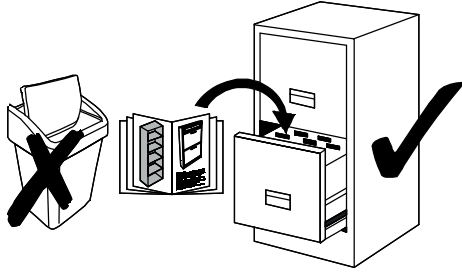

A10 8 x Ø8 x 35	B06 8 x Ø6,3 x 13	B52 4 x Ø7 x 50	C02 4 x fk.9	C20 4 x 2 mm	E05 4 x Ø3,0 x 12
I01 25 x Ø1,2 x 20	E17 22 x Ø3,5 x 15	F04 1 x 4 mm	F08 1 x 45 x 20 x 16	G02 8 x Ø15 x 11	G06 8 x L - 34
K01 4 x 20 x 20 x 16 / 6,5	K07 6 x 20 x 20 x 16 / 4,5	No 2 x 131 x 20	R19 1 x 35 x 40	Dd 4 x M4 x 20	

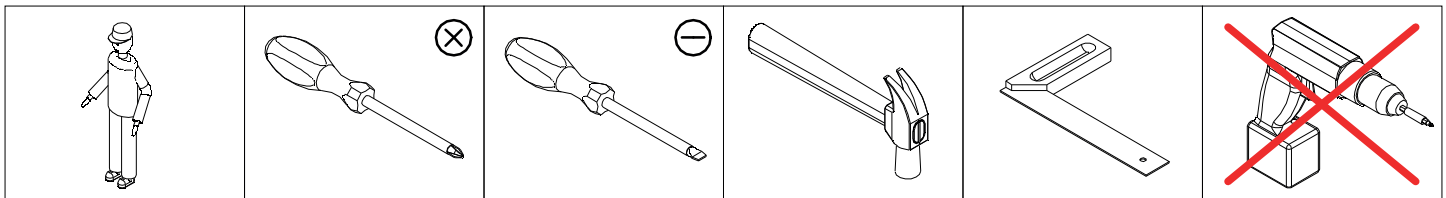

0 10 20 30 40 50 60 70 80 90 100 110 120 130 140 150 160 170 180 190

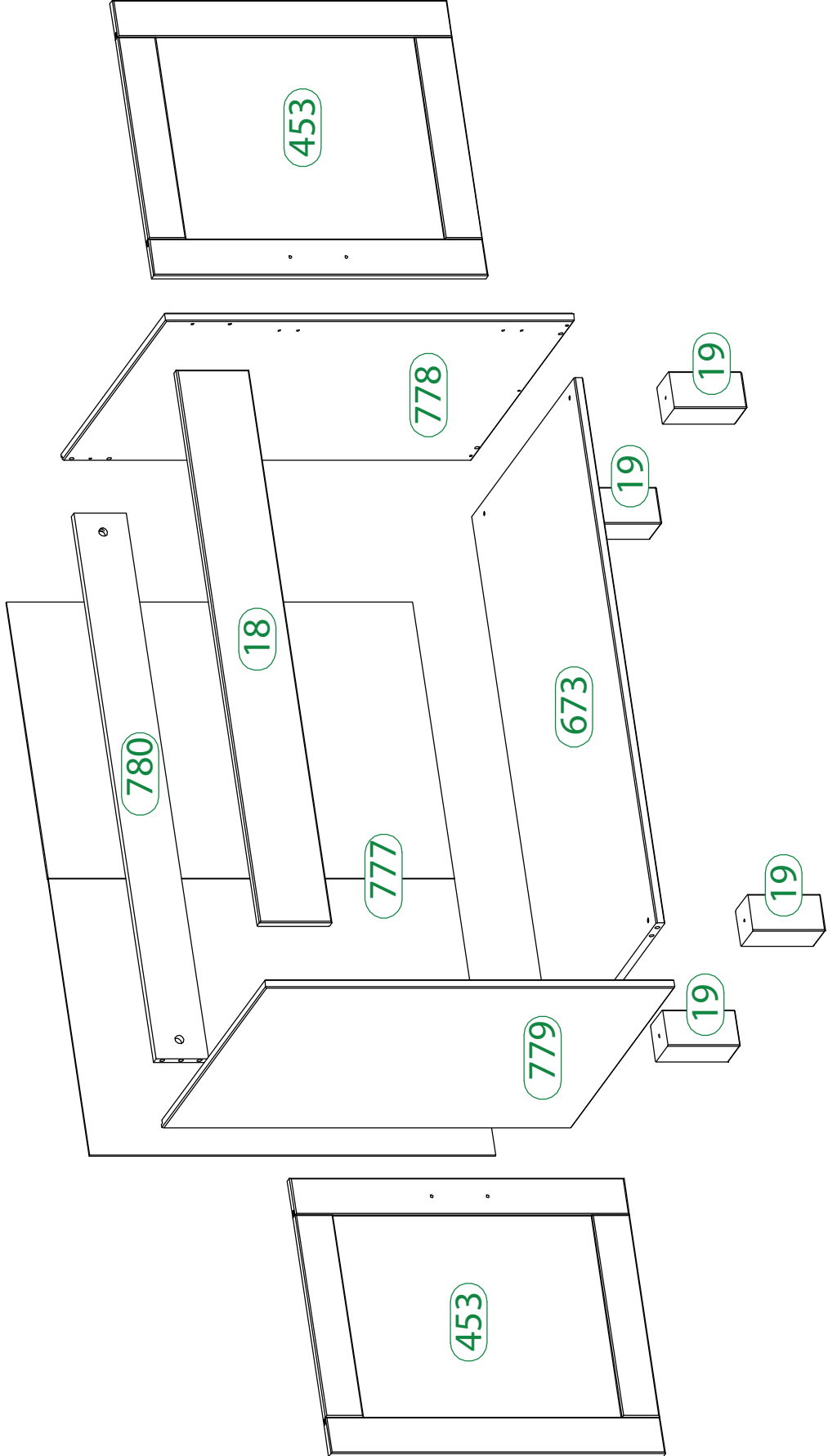

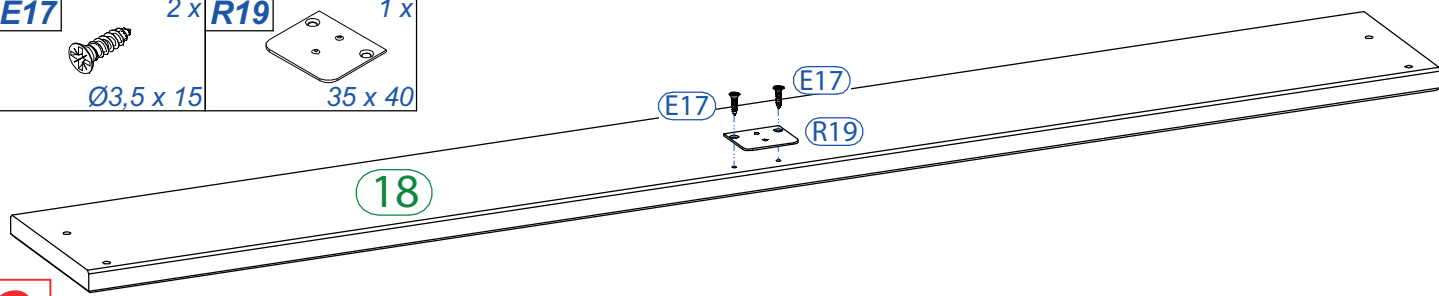
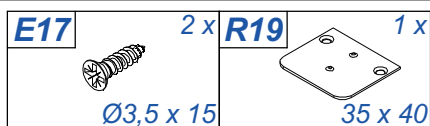
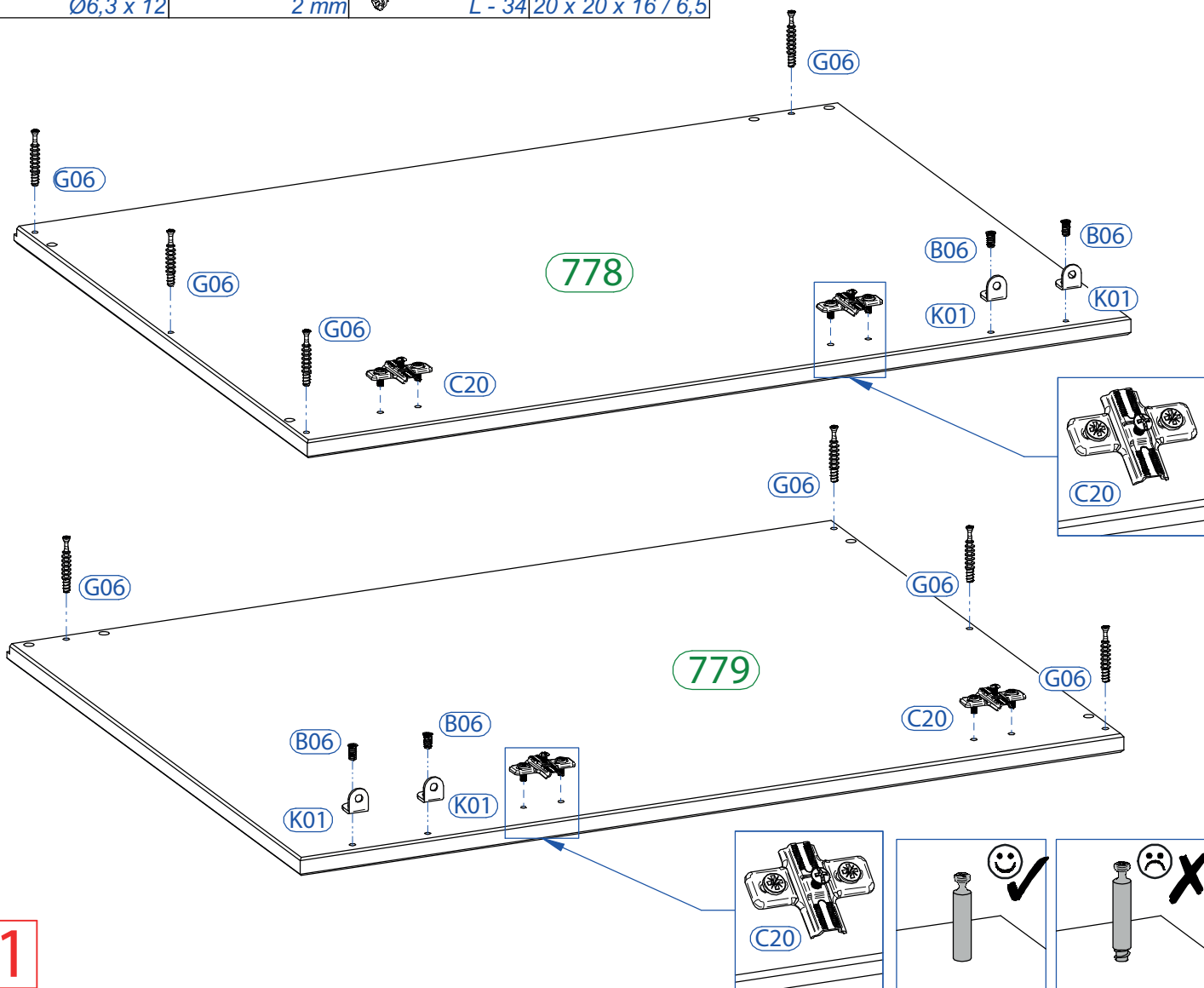
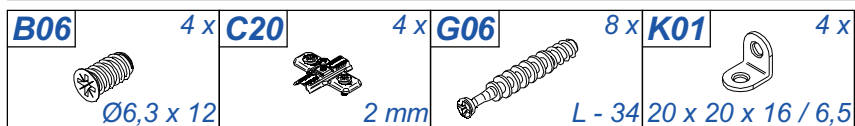
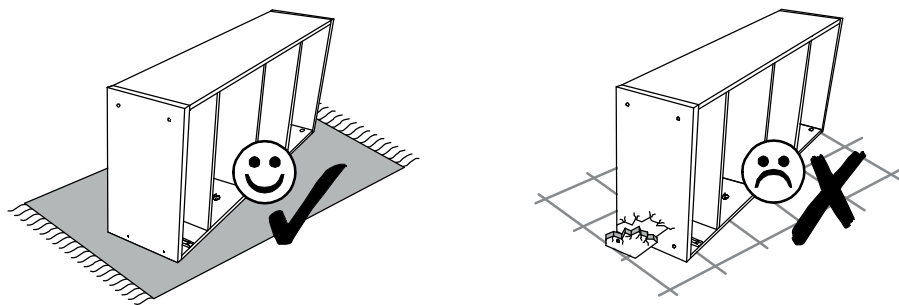

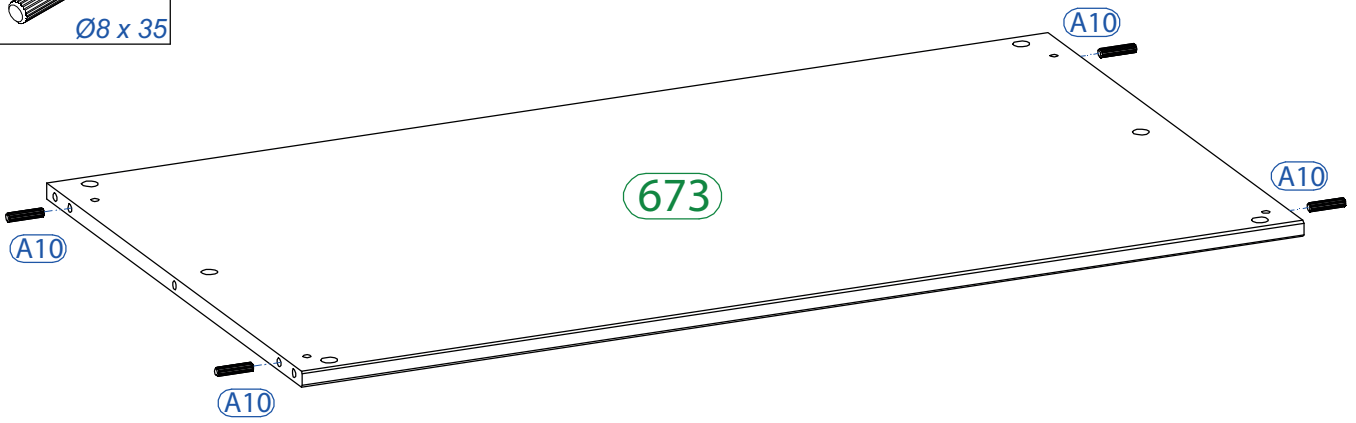
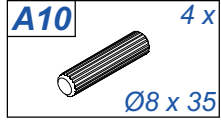

3

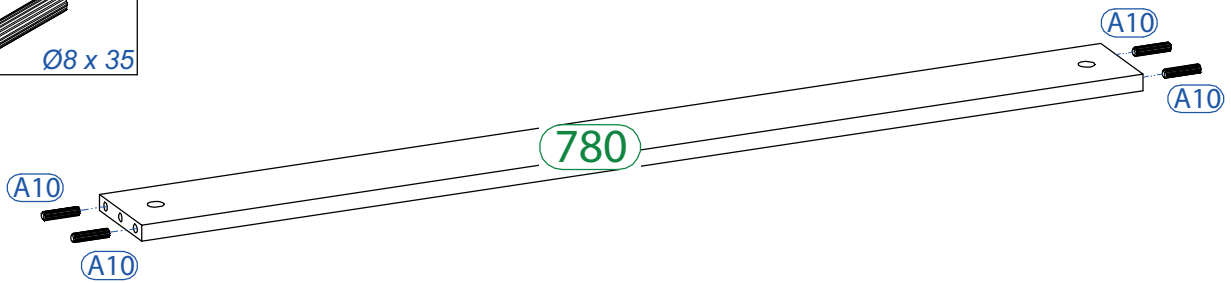
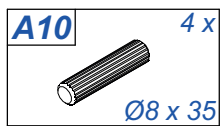

4

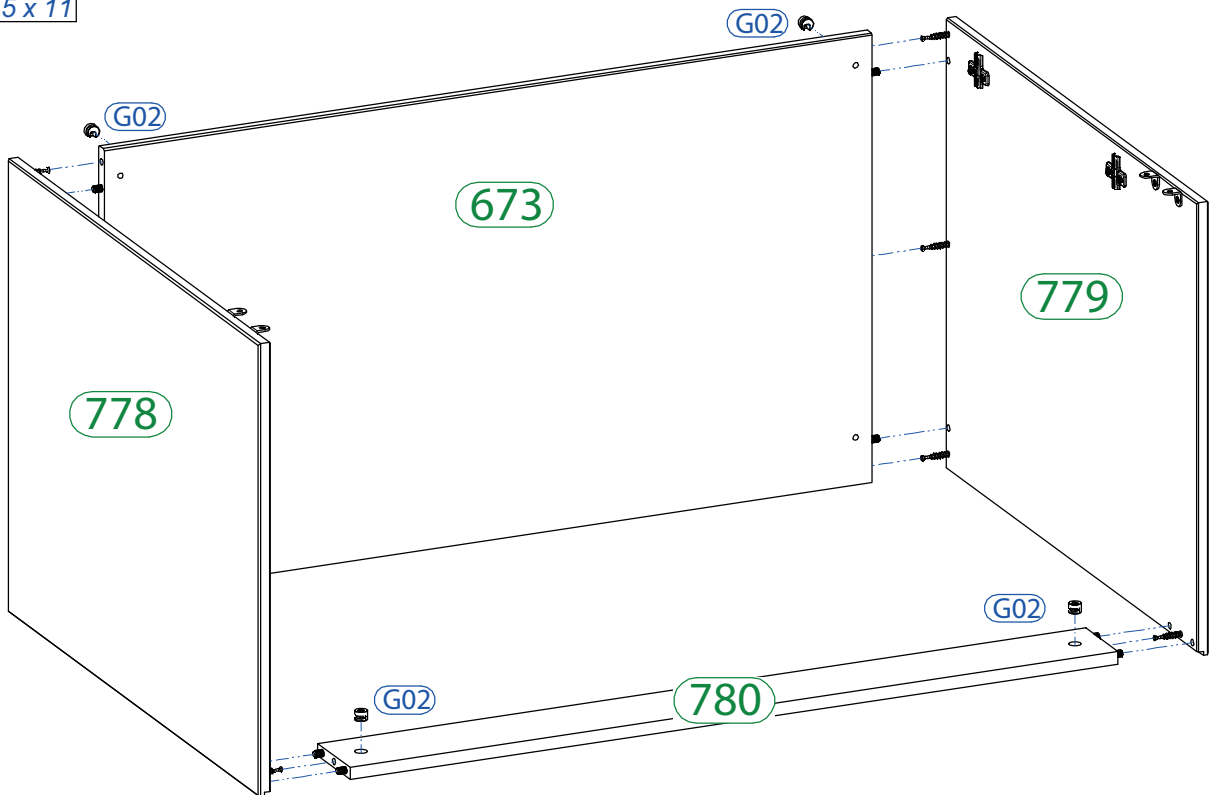
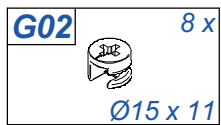

5

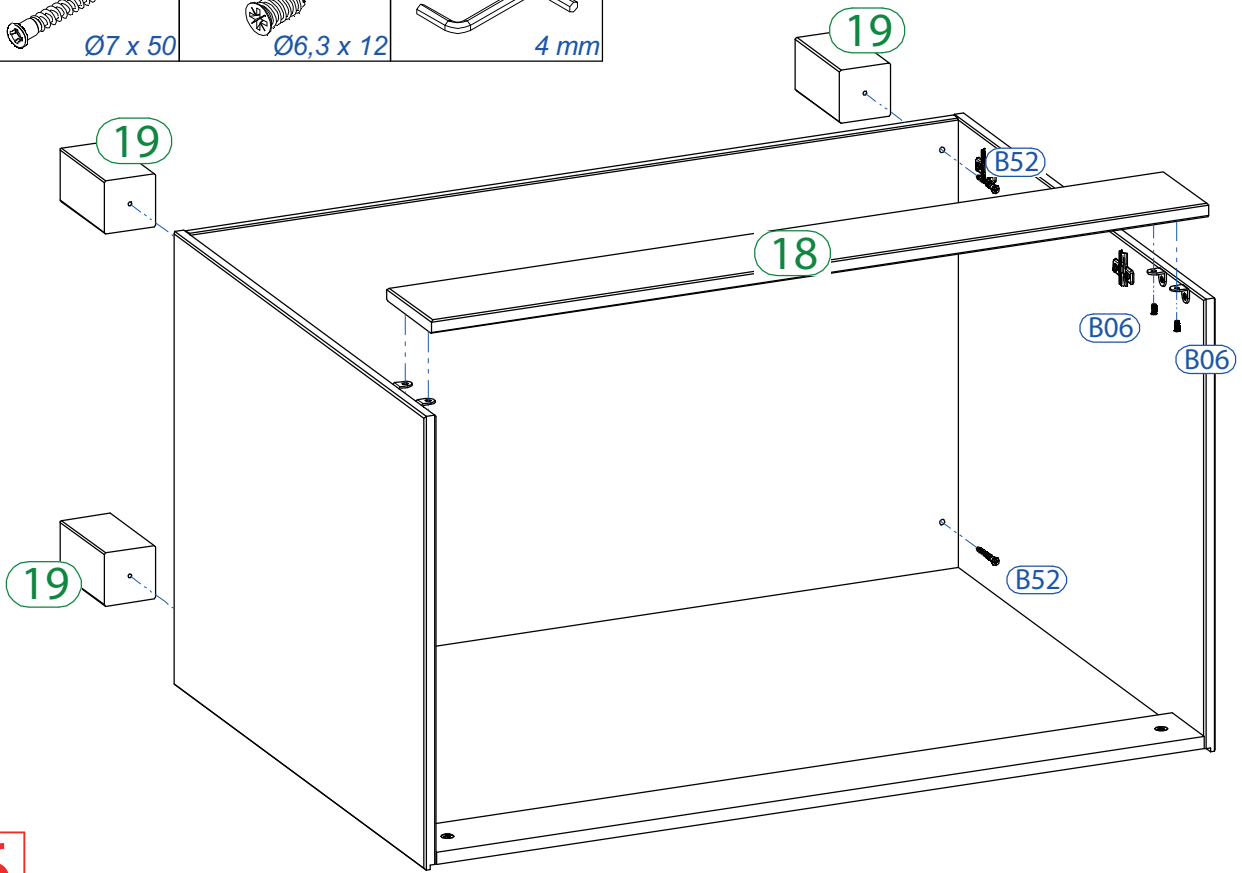
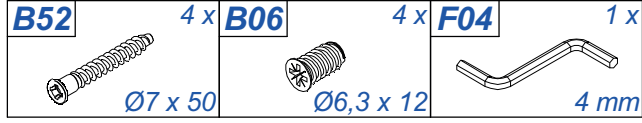

6

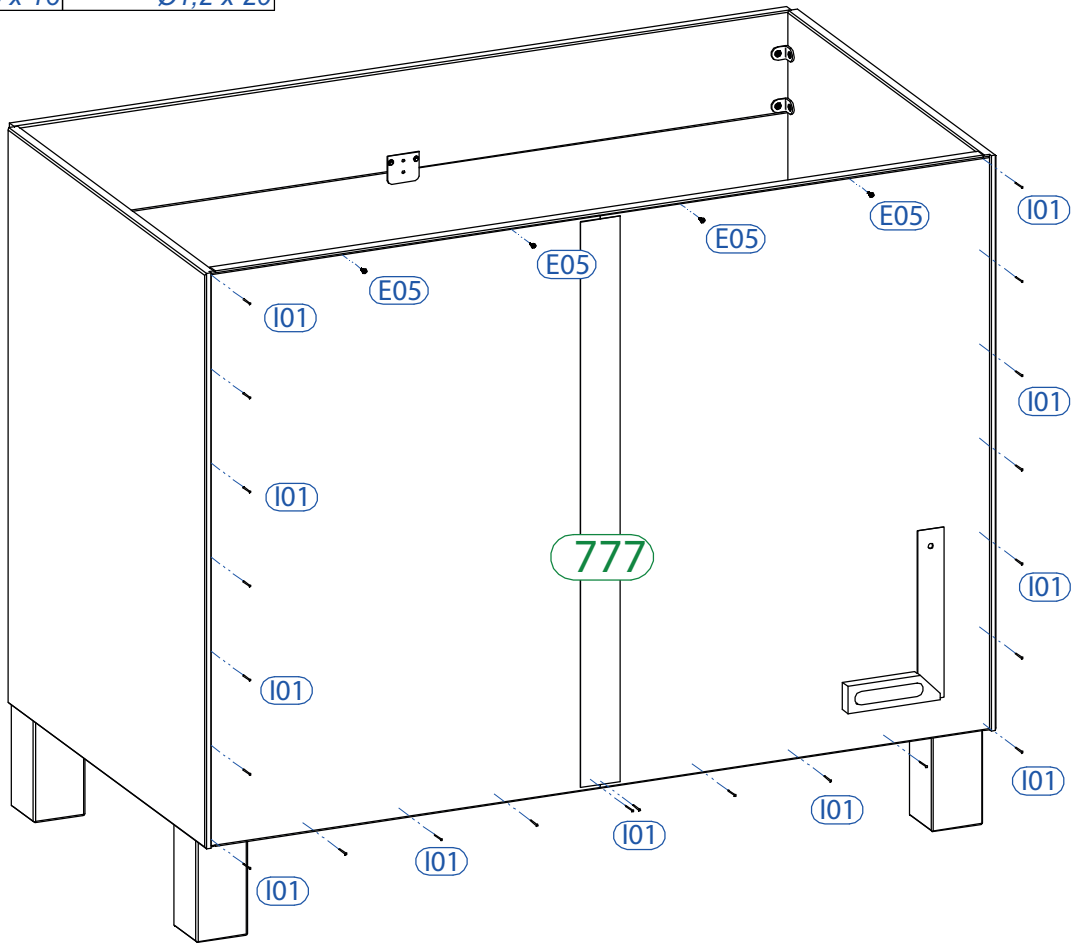
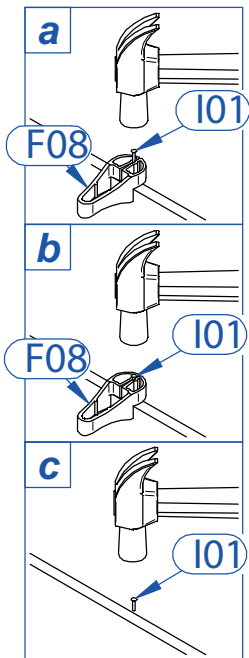
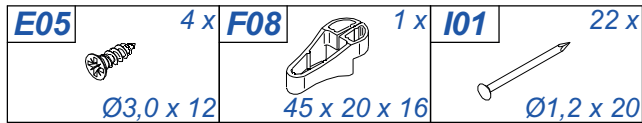

7

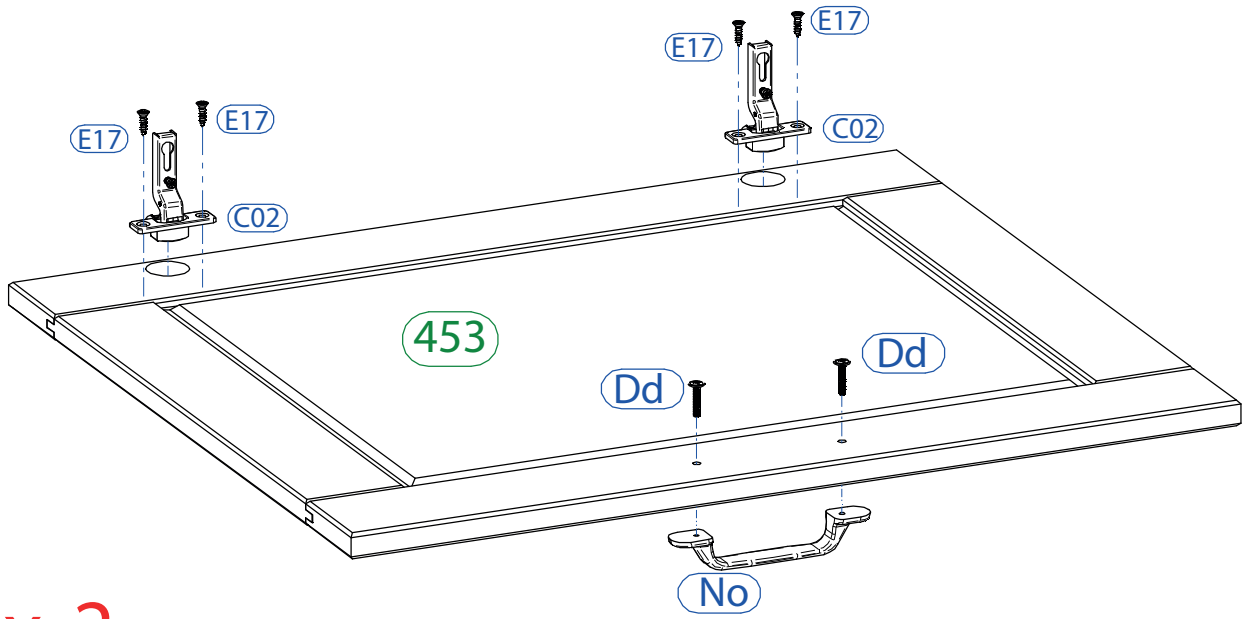
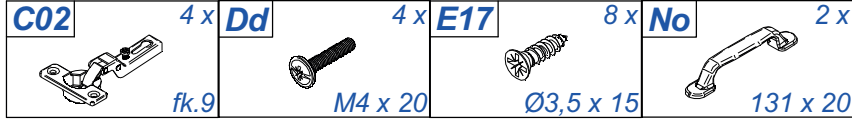

8 x 2

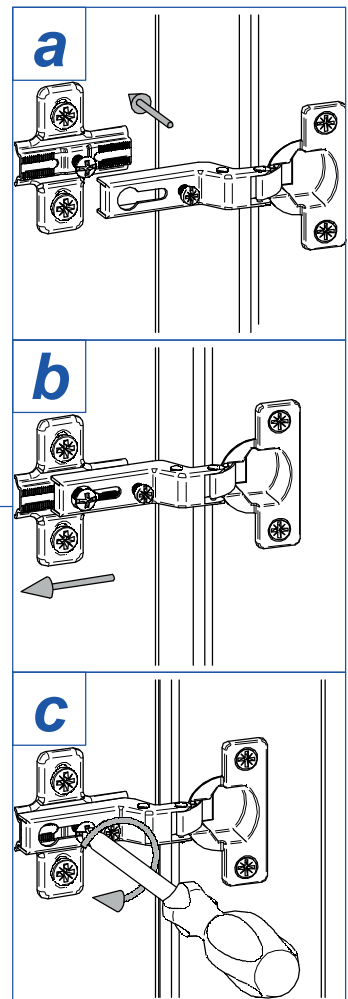
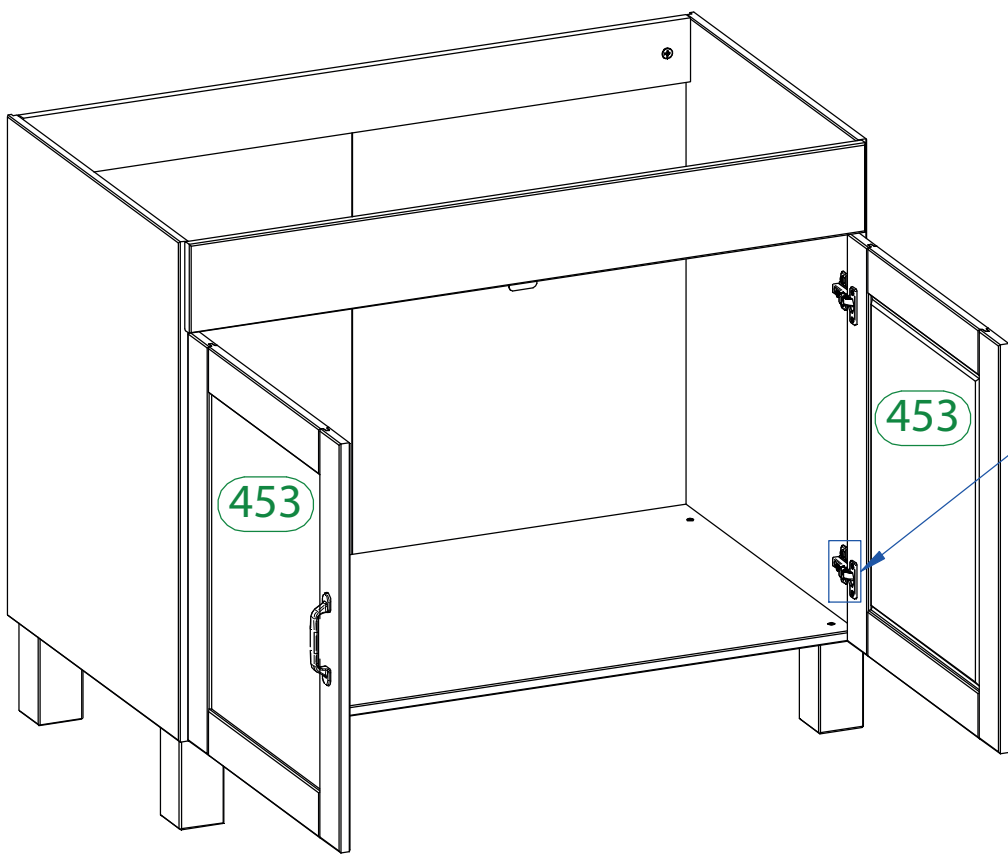

9

E17

6 x

K07

6 x



Ø3,5 x 15 20 x 20 x 16 / 4,5

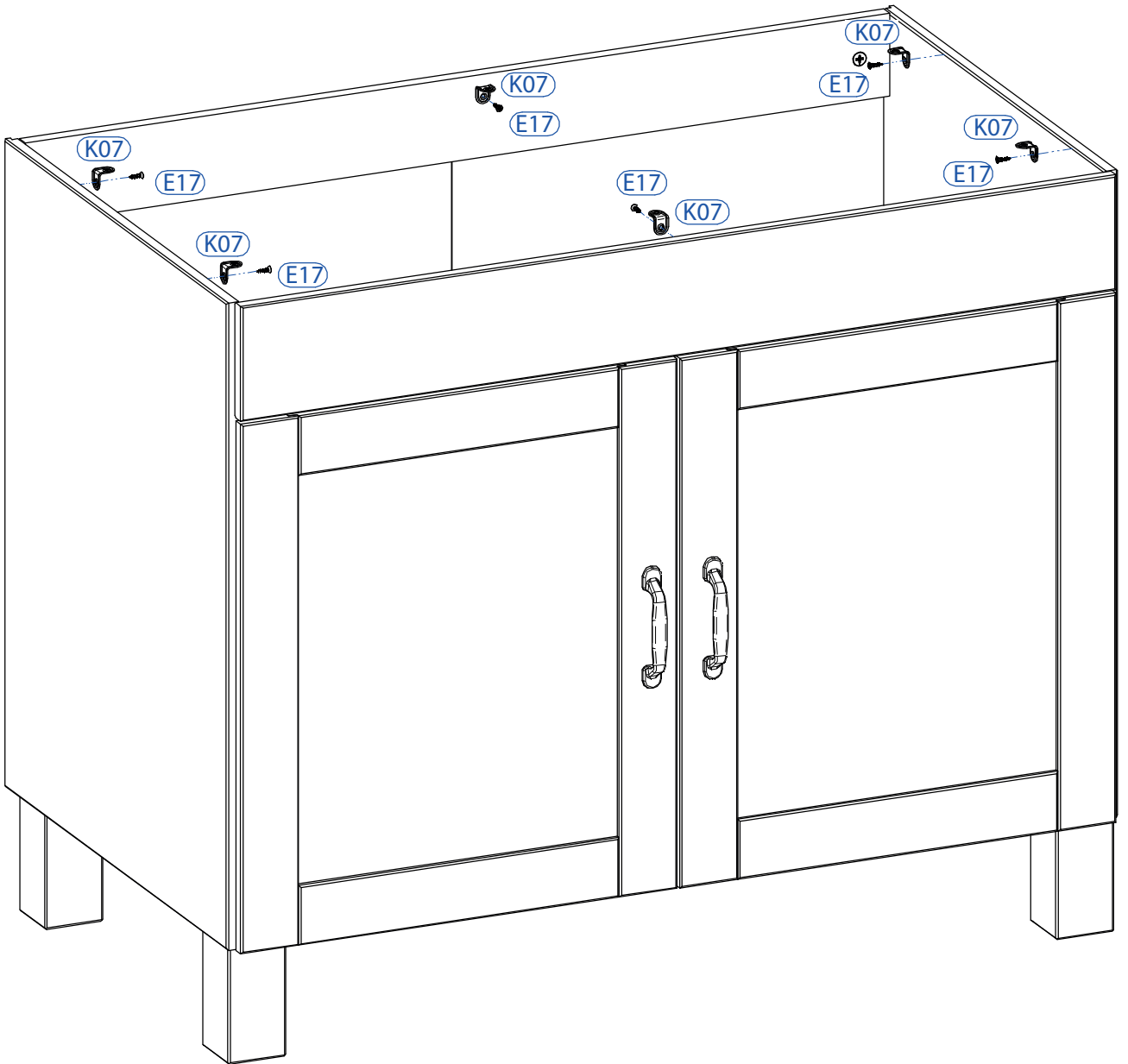

E17 6 x
Ø3,5 x 15

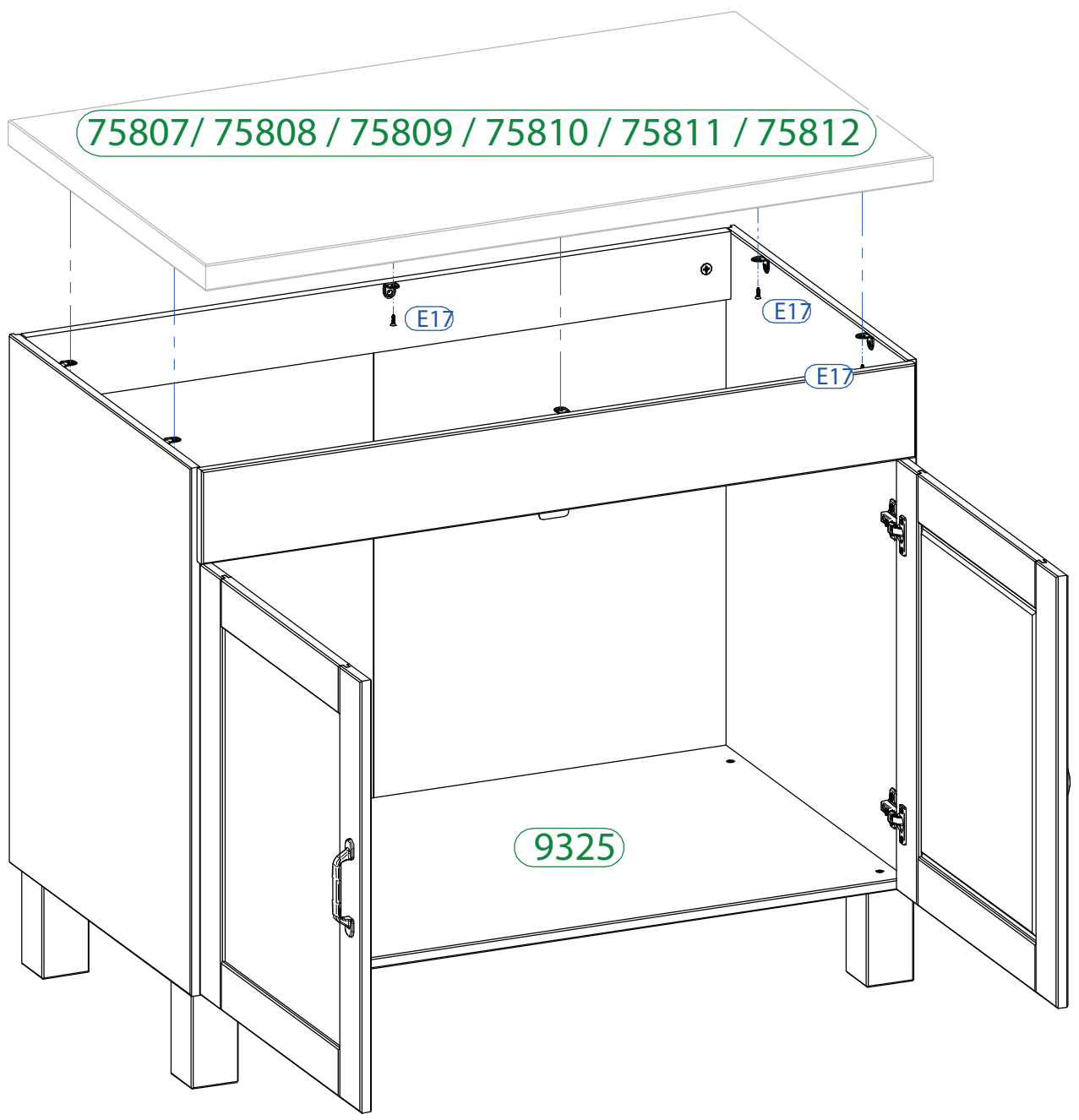



D	Türen einstellen (Scharniere justieren)
GB	Adjusting the doors (adjusting the hinges)
NL	Deuren instellen (scharnieren afstellen)
PL	Nastawić drzwi (wyrównać zawiasy)
TR	Kapıların ayarlanması (menteşelerin seviye ayarı)
RU	Регулировка дверей (регулировка шарнира)
FR	Régler les portes (ajuster les charnières)
IT	Sistemare le porte (regolare le cerniere)
CZ	Vyrovňte dvířka (seřďte závěsy)
SK	Nastavenie dverí (nastavenie závesov)
HU	Állítsa be az ajtókat (állítsa be a zsanérokot)
RO	Reglare ușii (ajustare balamale)

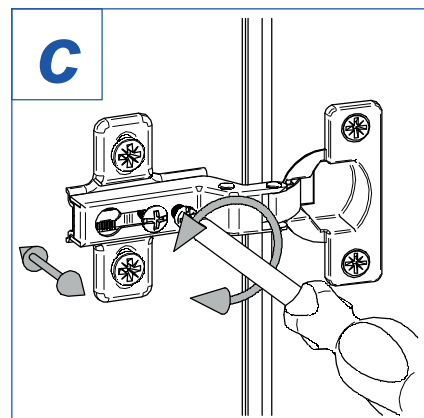
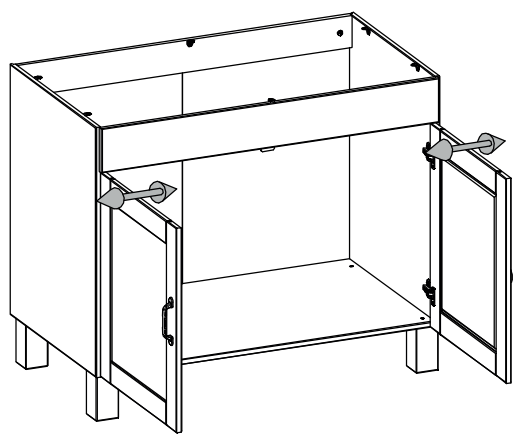
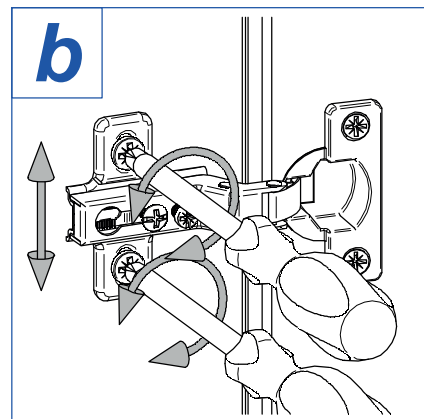
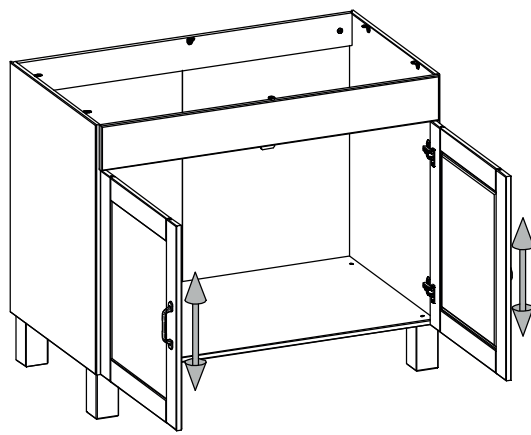
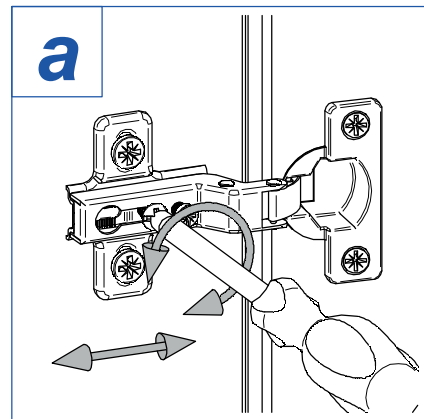
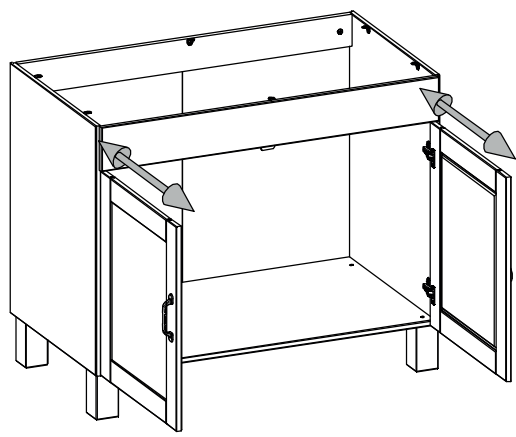

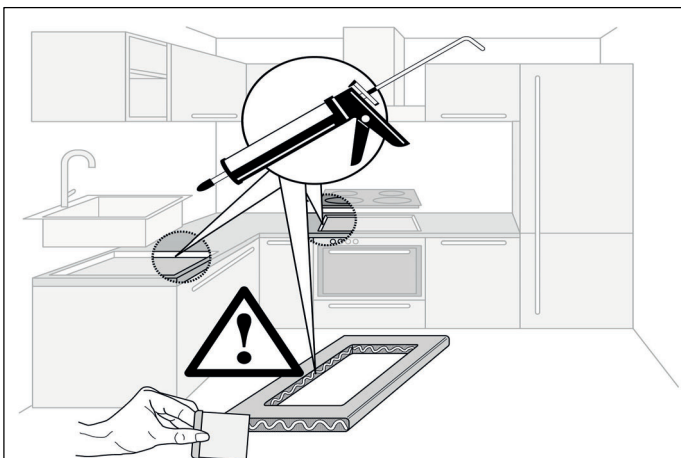
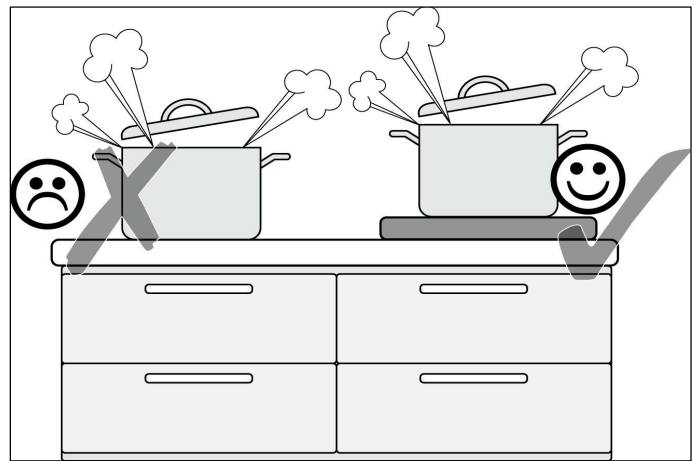
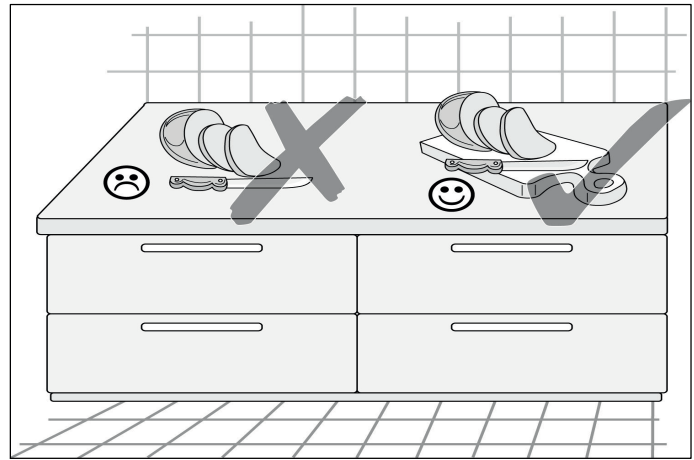
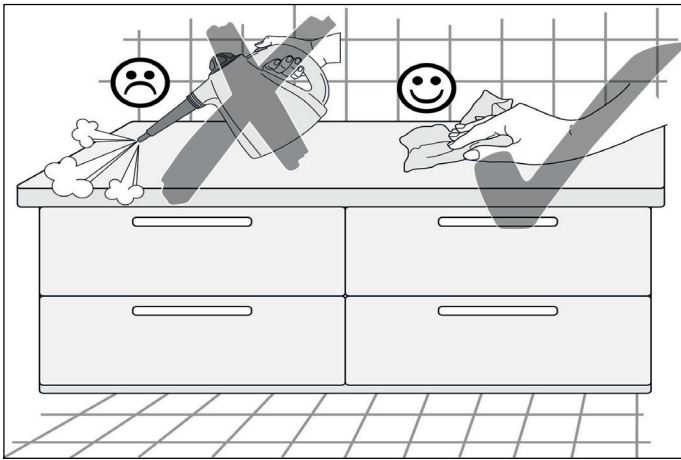
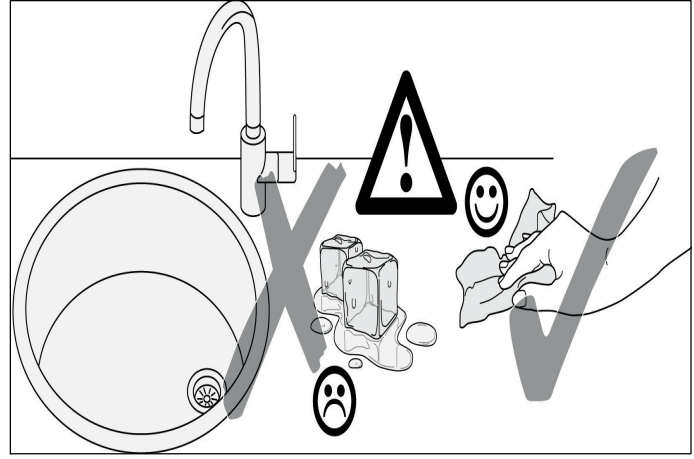
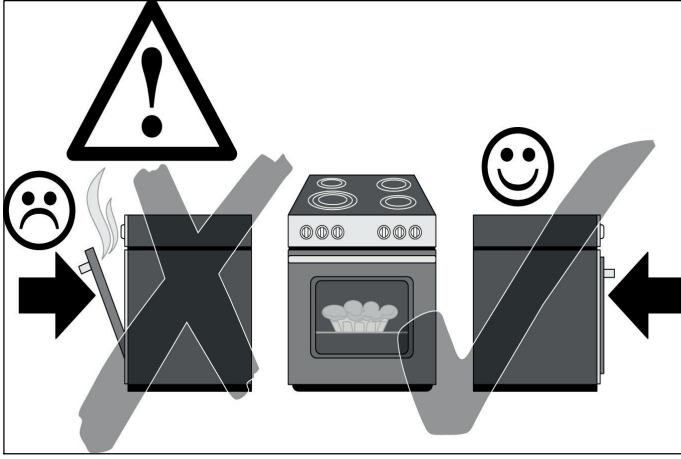

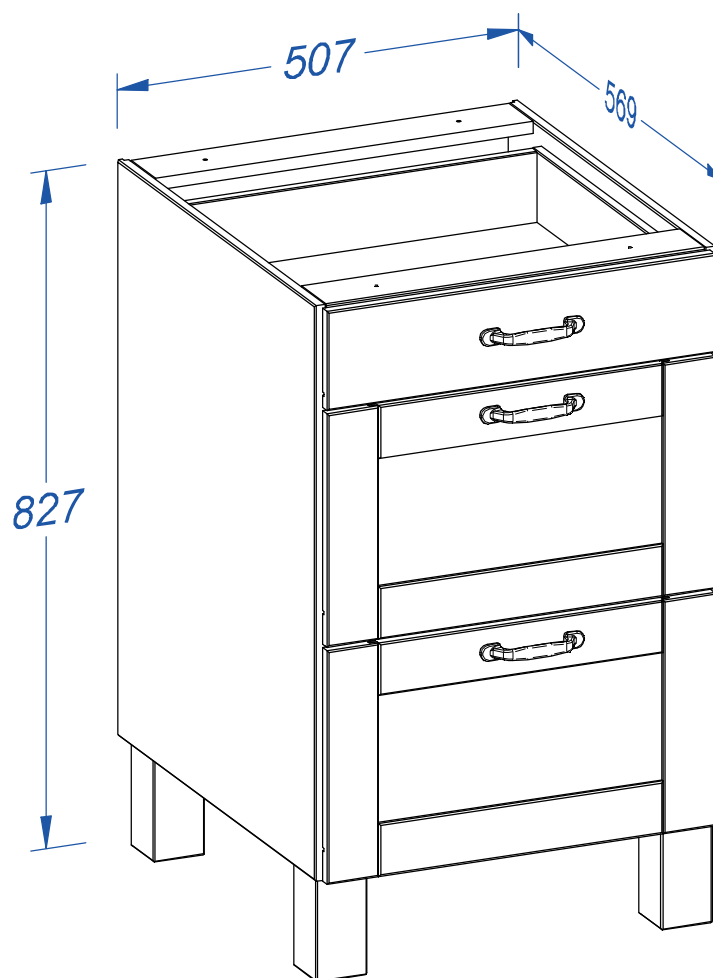

(D) *Montageanleitung*

(NL) *Handleiding voor de montage*

(TR) *Montaj talimatı*

(FR) *Notice de montage*

(CZ) *Montážní návod*

(HU) *Szerelési útmutató*

(GB) *Assembly instructions*

(PL) *Instrukcja montażu*

(RU) *Инструкция по монтажу*

(IT) *Istruzioni di montaggio*

(SK) *Návod na montáž*

(RO) *Instrucțiuni de montaj*



Name • Nom • Nome • Naam • Nazwa • Jméno •
 Názov • Név • Denumire • Isim • Название

Nr. • No. • N° • Номер • Č • Sz

Typ • Type • Tip • Tipus • Tipo • Тип

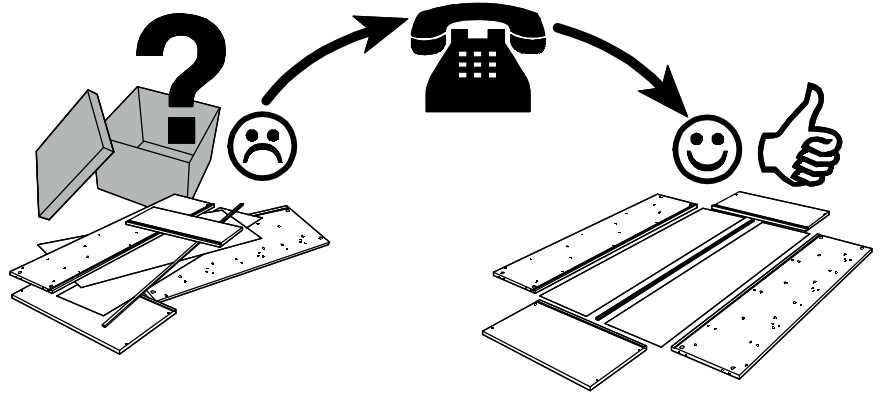
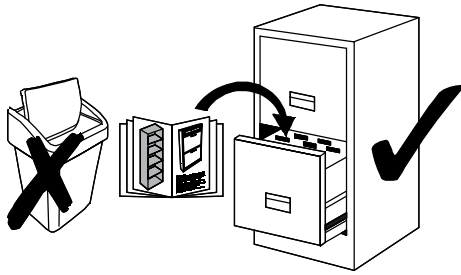

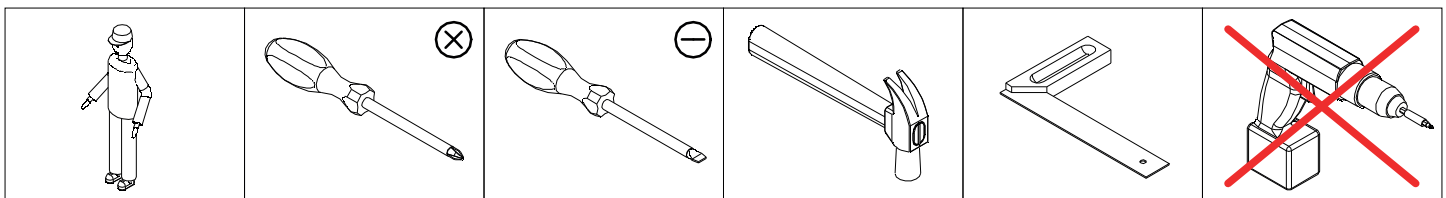

A10 22 x Ø8 x 35	B01 18 x Ø5,8 x 11	B52 4 x Ø7 x 50	D02 2 x M4 x 10	Dd 6 x M4 x 20	E17 12 x Ø3,5 x 15
E22 16 x Ø3,5 x 35	E32 4 x Ø4,0 x 30	F04 1 x 4 mm	F08 1 x 45 x 20 x 16	G02 20 x Ø15 x 11	G06 20 x L - 34
I01 25 x Ø1,2 x 20	No 3 x 131 x 20	Q02 2 x 17 x 430	Q16 2 x 400 mm, L + R		
Q17 2 x 400 mm, L + R					

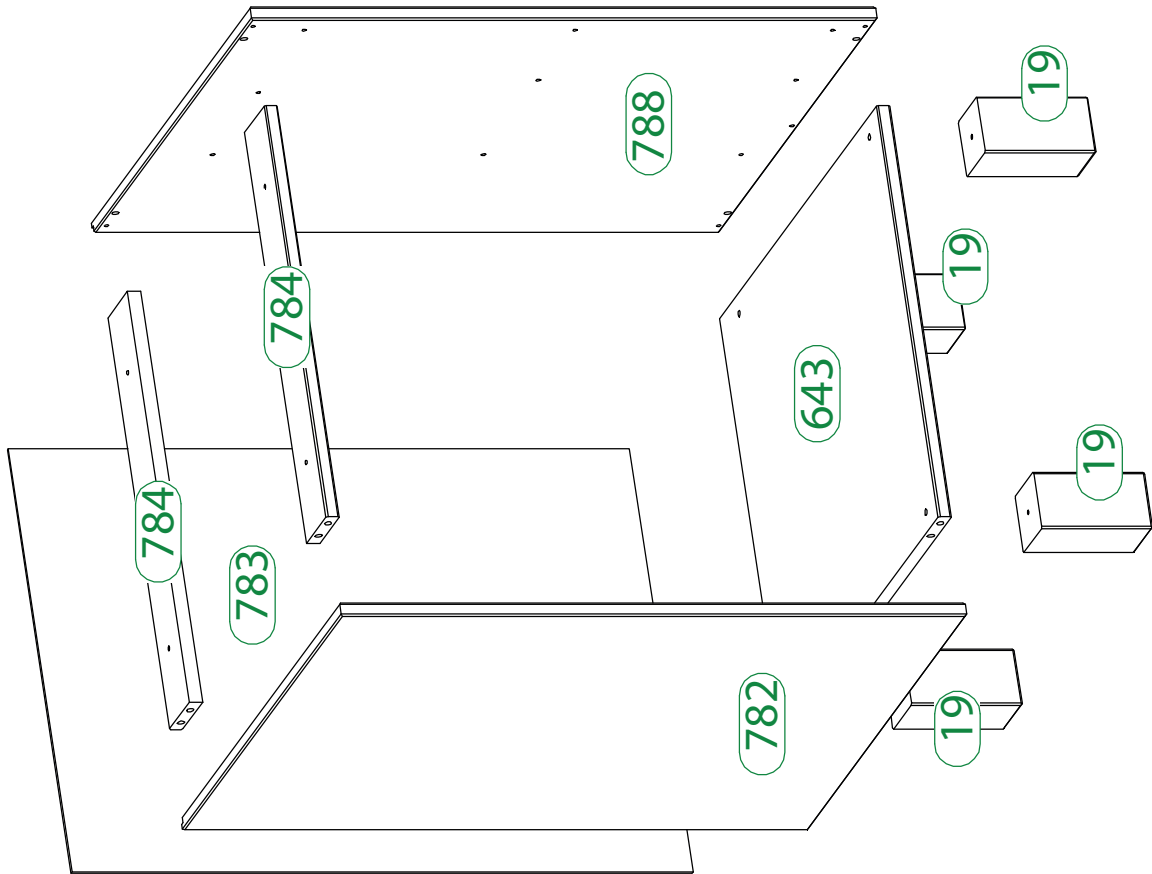
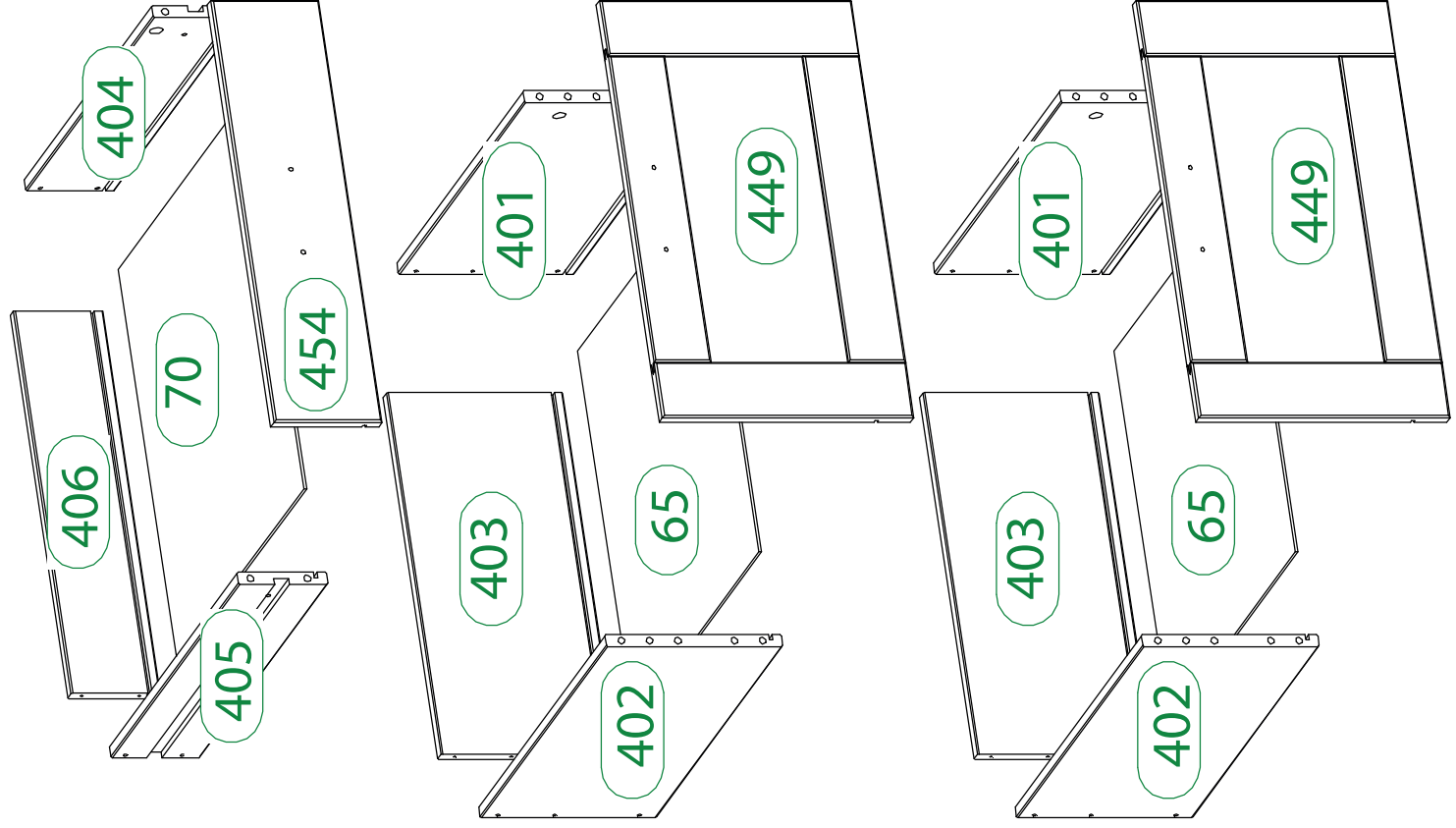

0 10 20 30 40 50 60 70 80 90 100 110 120 130 140 150 160 170 180 190

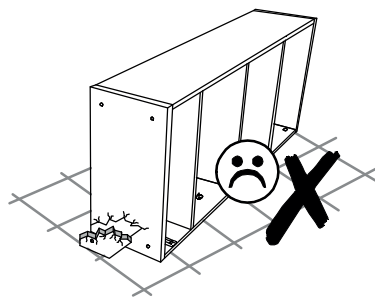
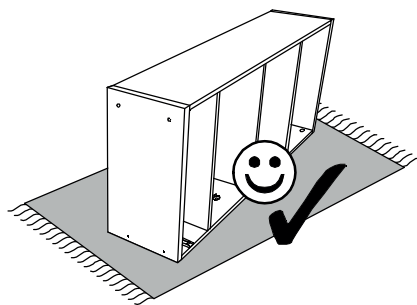

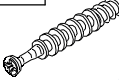
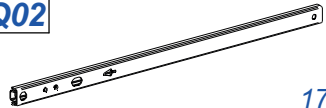
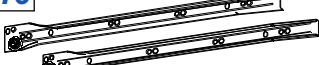

B01	18 x	G06	10 x	Q02	2 x	Q16	2 x
	$\text{Ø}5,8 \times 11$		L - 34		17 x 430		400 mm, L + R

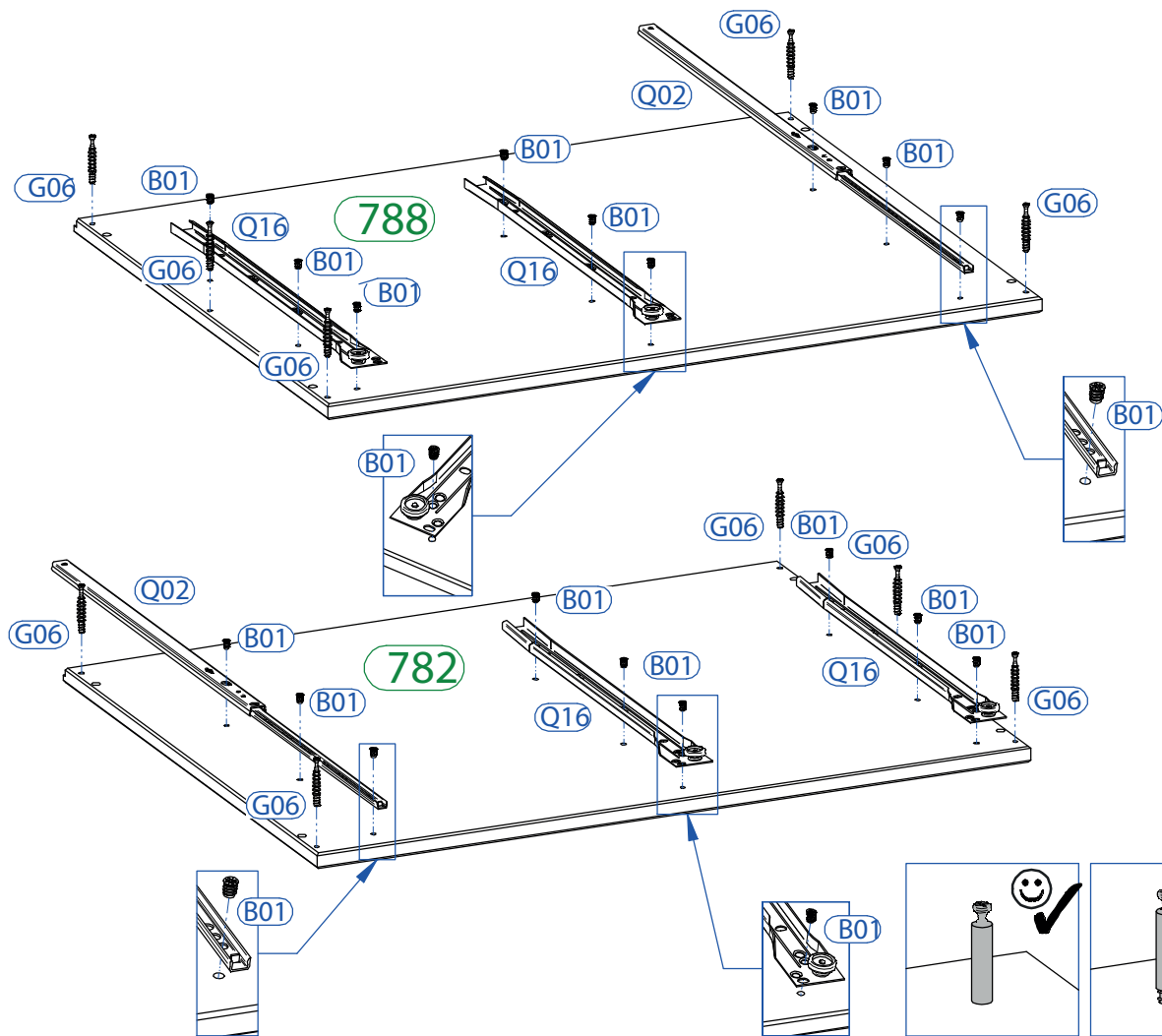

1

A10	4 x
	$\text{Ø}8 \times 35$

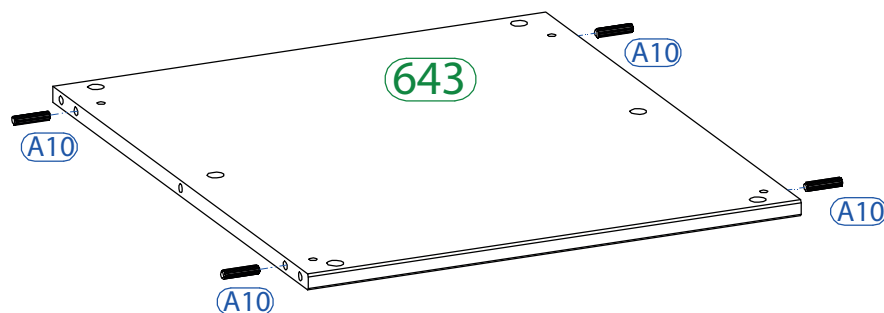

2

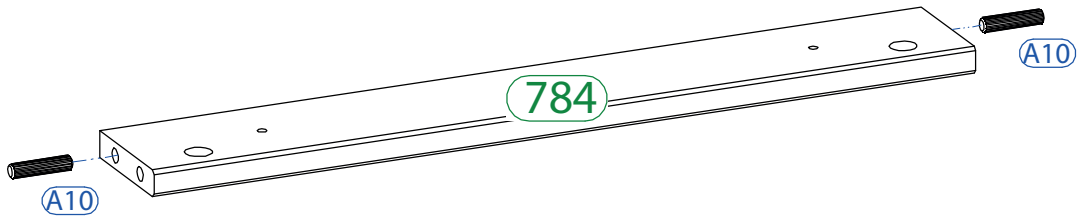
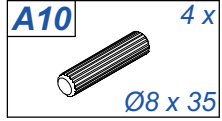

3 x2

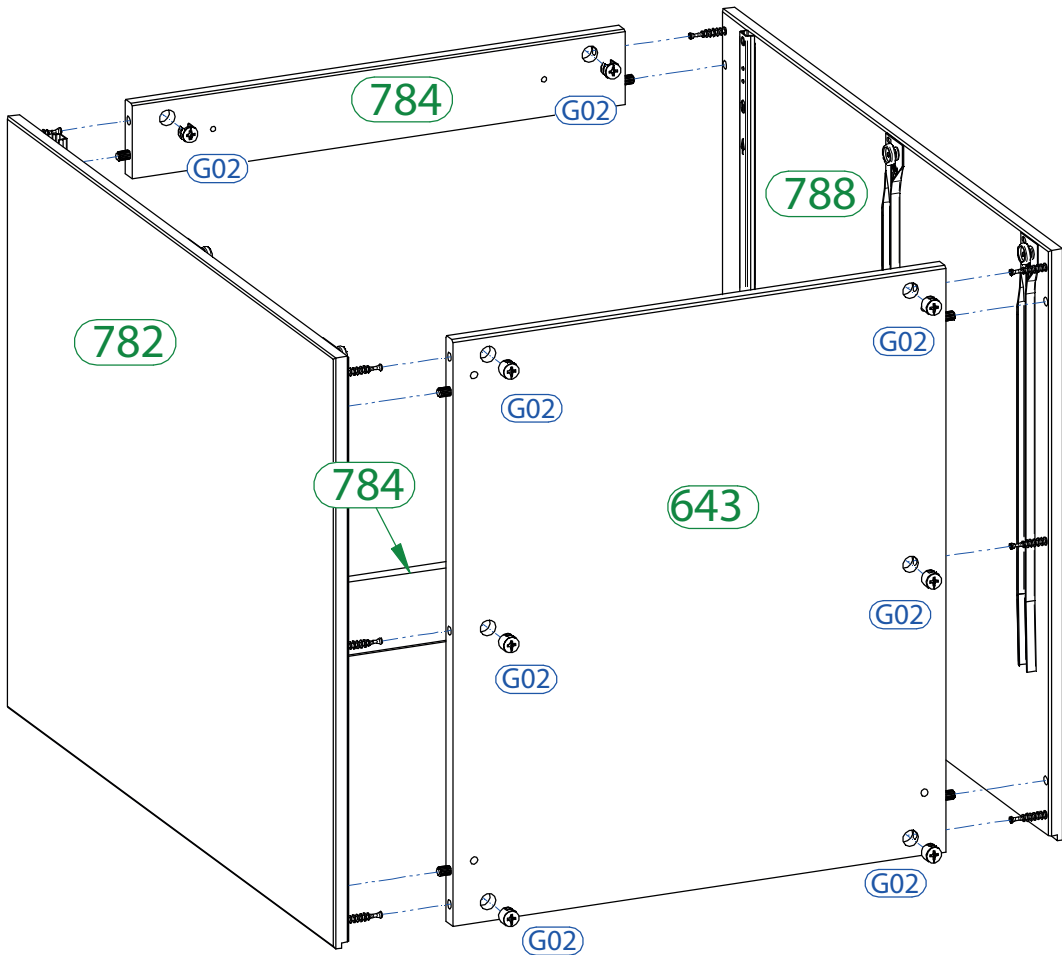
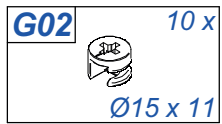

4

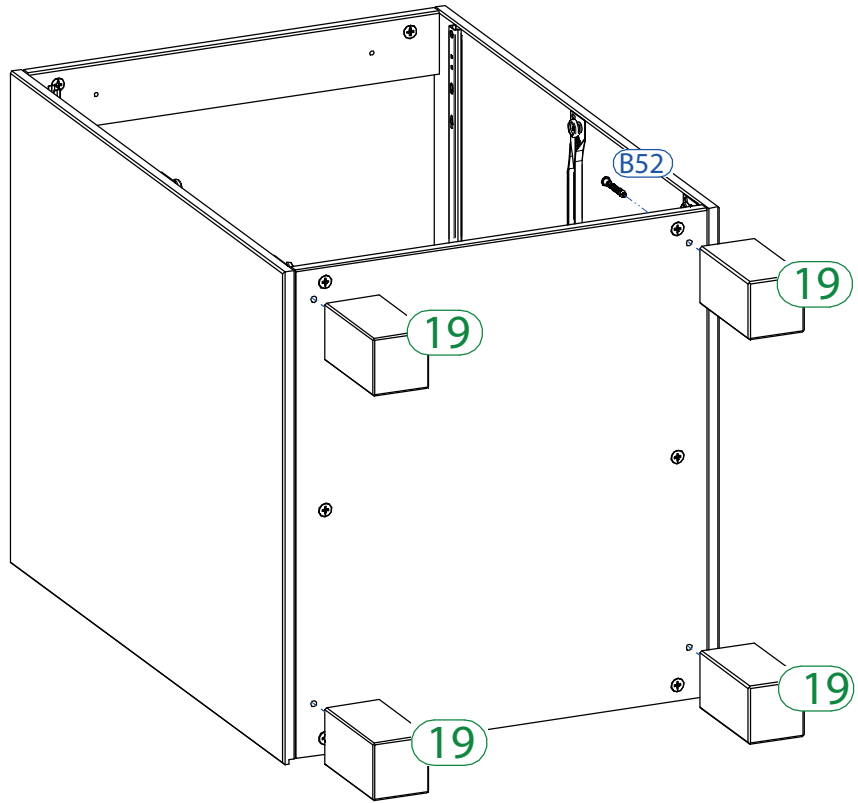
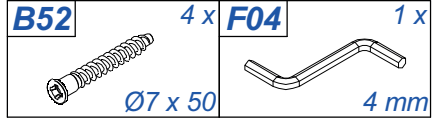

5

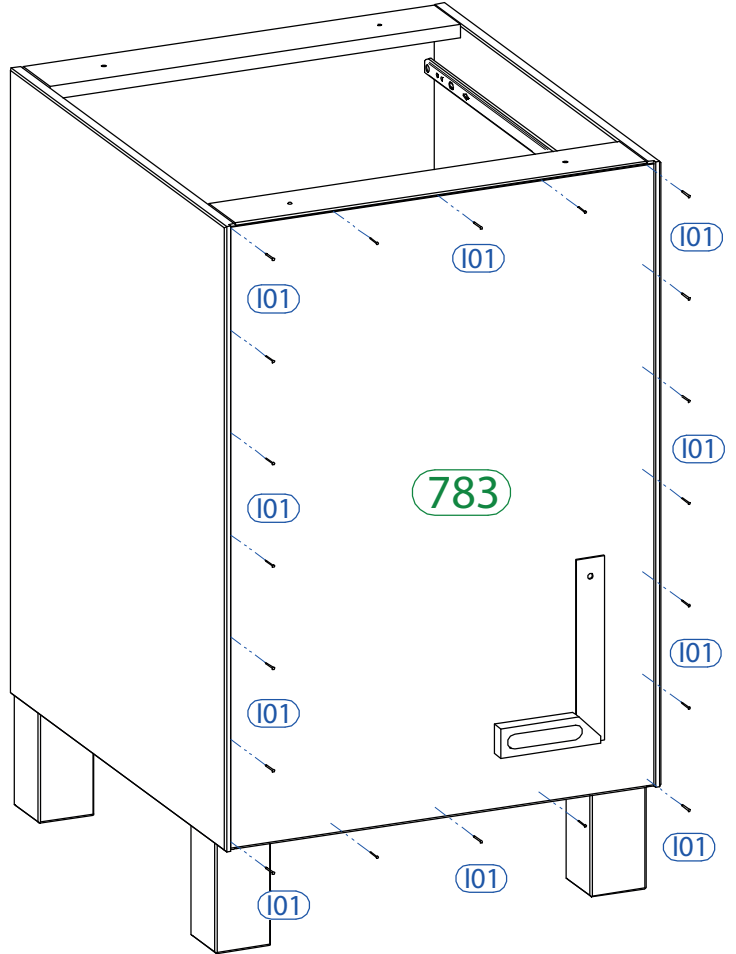
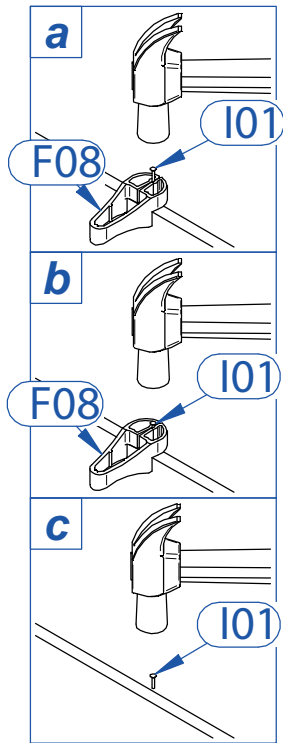
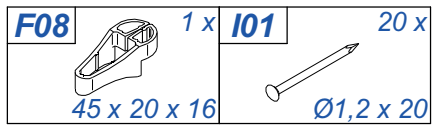



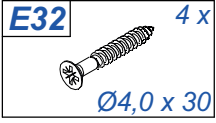

6

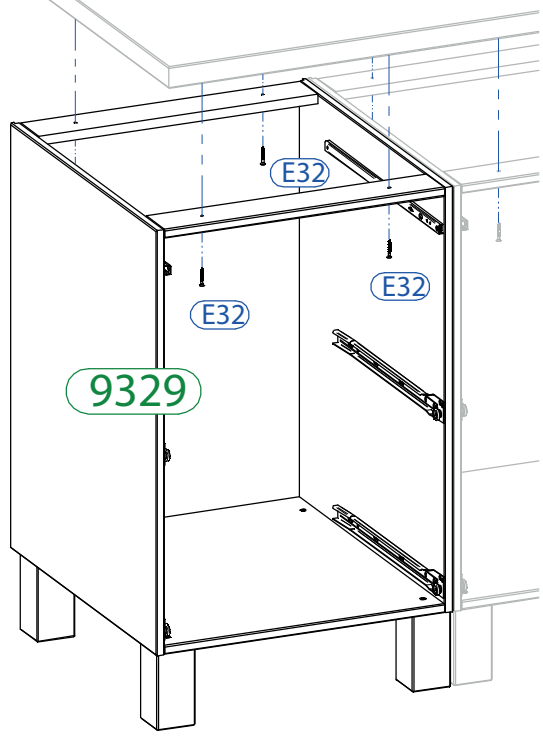

75807/75808/75809/75810/75811/75812

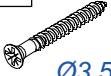

7

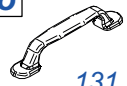
A10 2 x  Ø8 x 35	Dd 2 x  M4 x 20	E22 4 x  Ø3,5 x 35	G06 2 x  L - 34	G02 2 x  Ø15 x 11	No 1 x  131 x 20
--	---	--	---	--	--

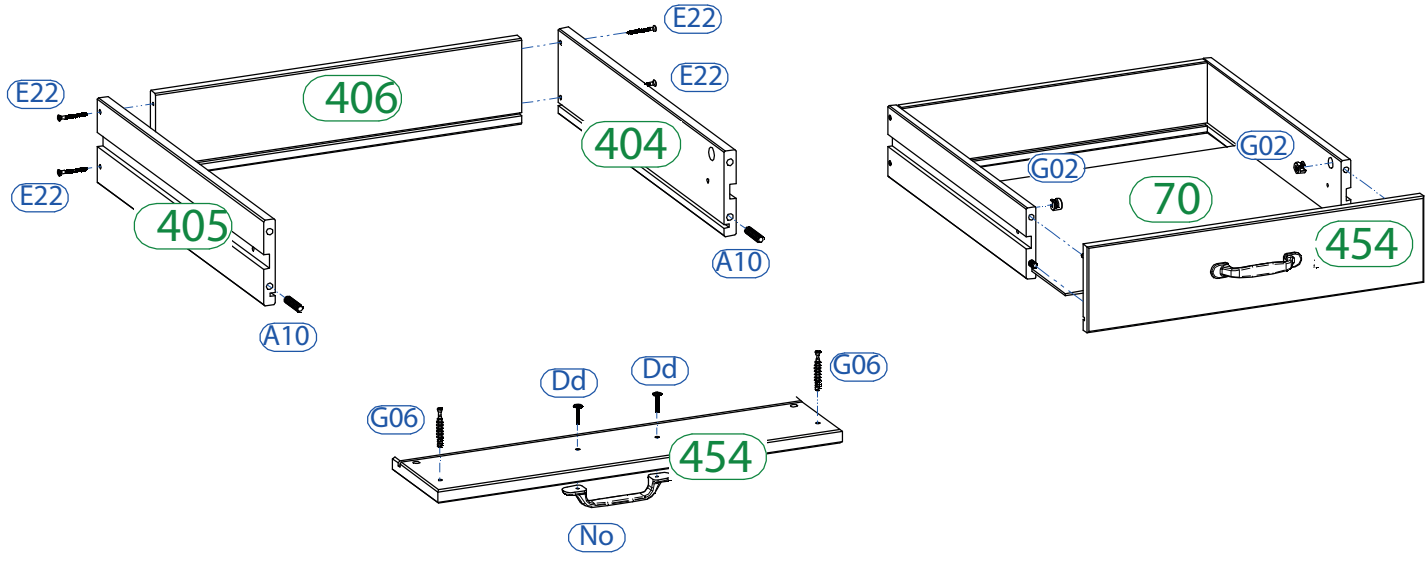

8

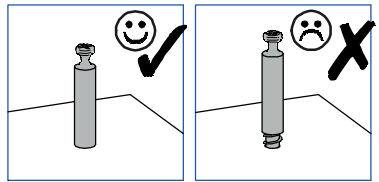

A10	12 x	Dd	4 x	E17	12 x	E22	12 x	G02	8 x	G06	8 x
	Ø8 x 35		M4 x 20		Ø3,5 x 15		Ø3,5 x 35		Ø15 x 11		L - 34
No	2 x	Q17			2 x						
	131 x 20					400 mm, L + R					

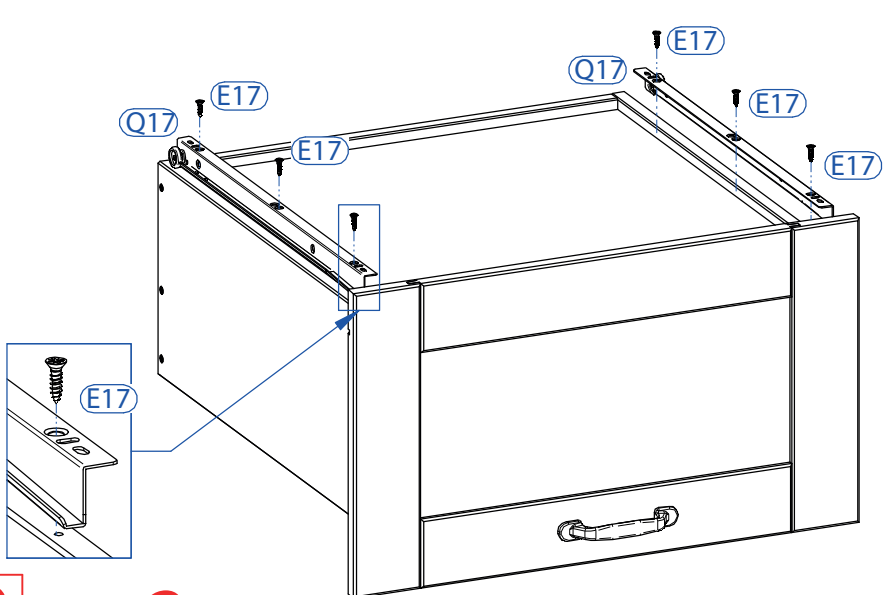
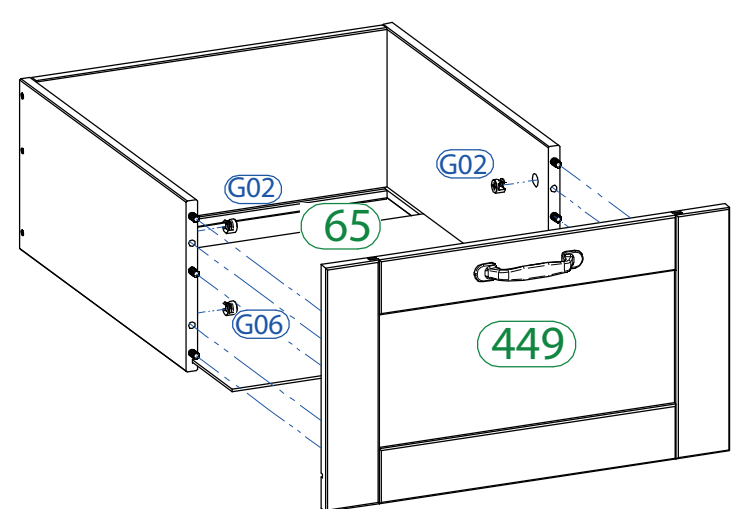
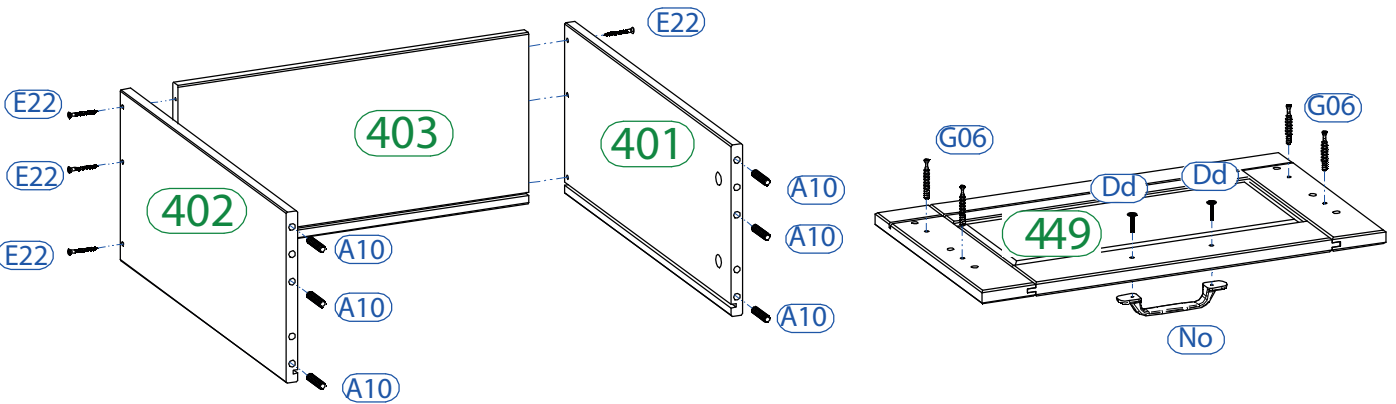

9 x 2

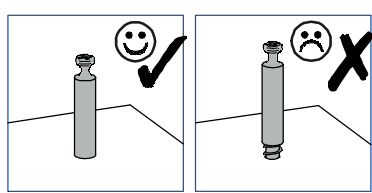

D02

2 x



M4 x 10

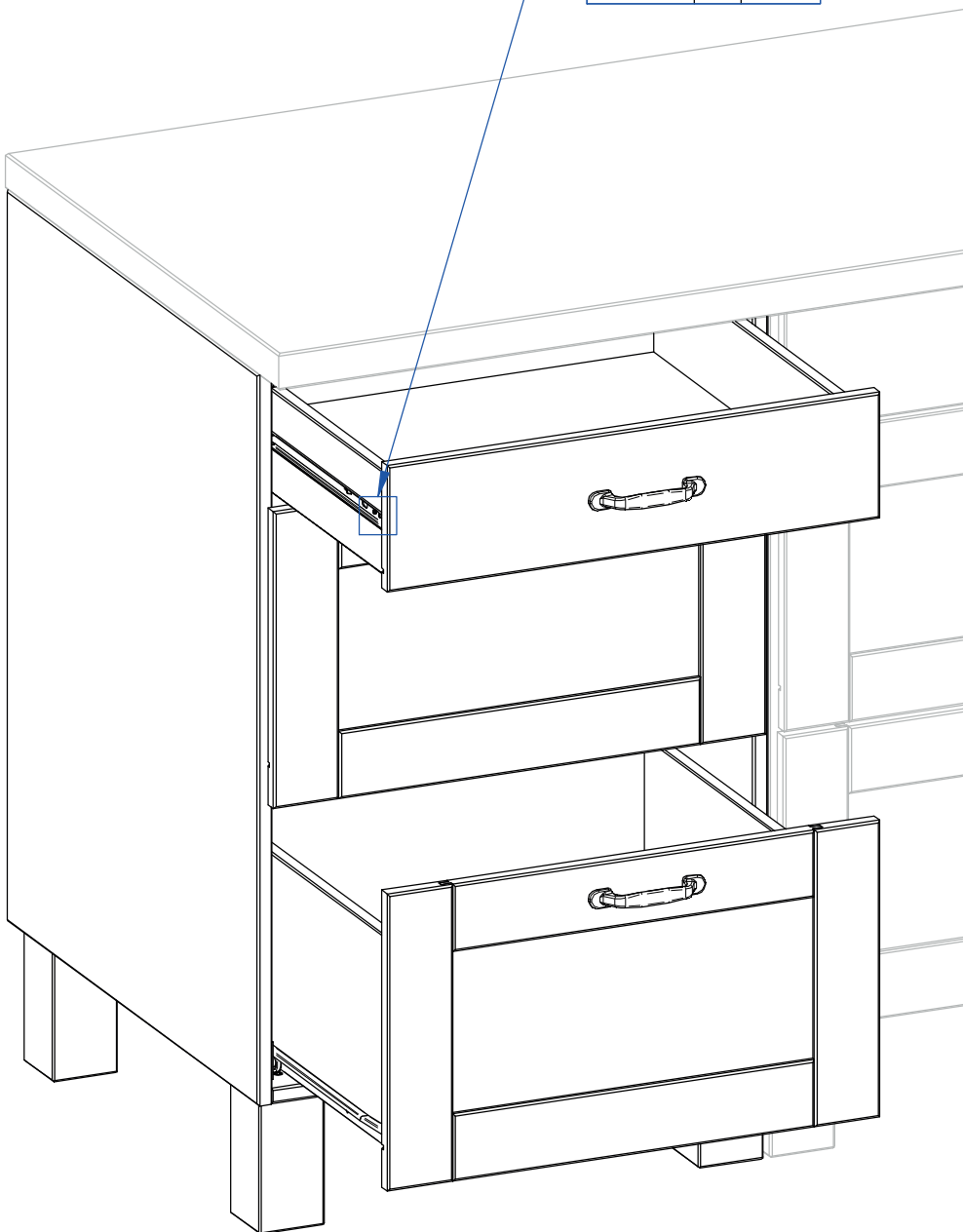
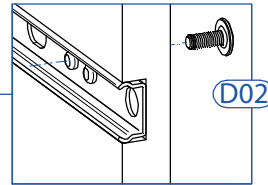

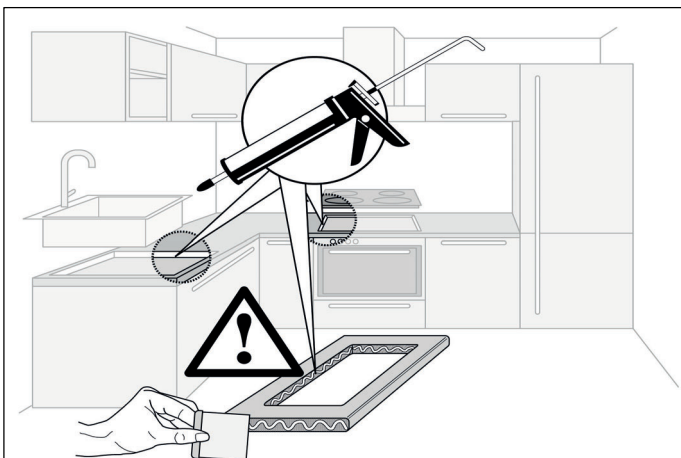
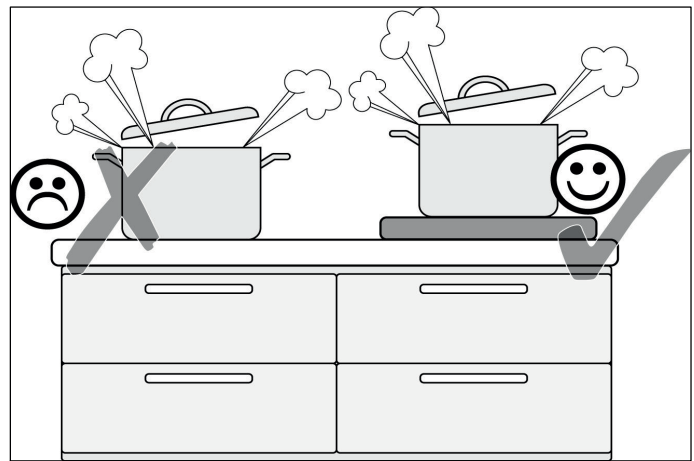
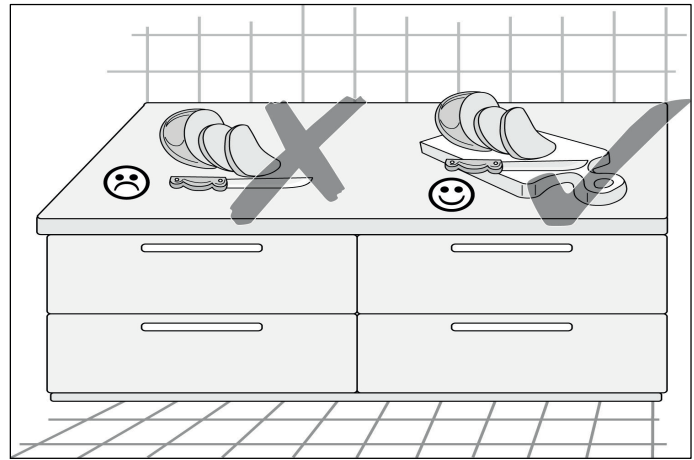
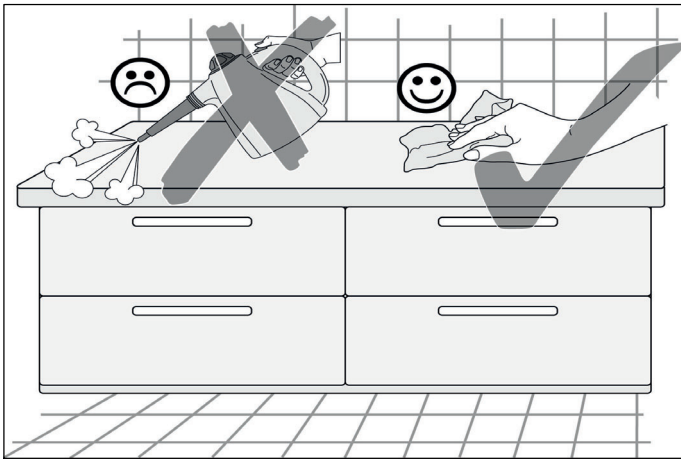
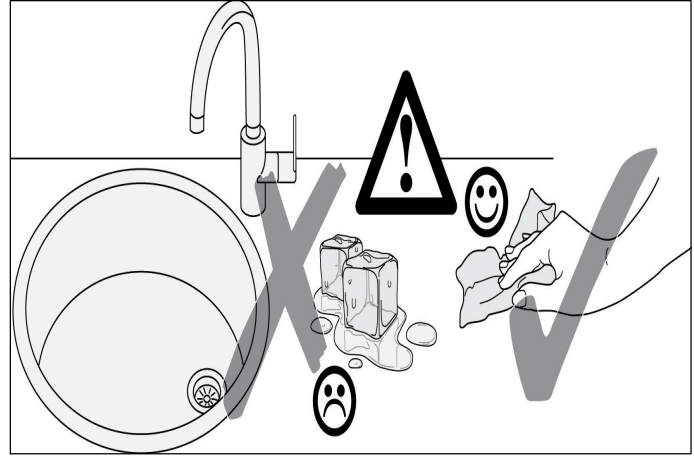
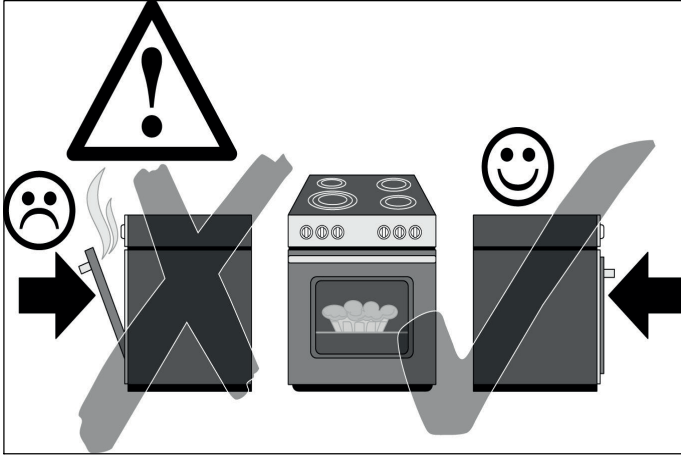

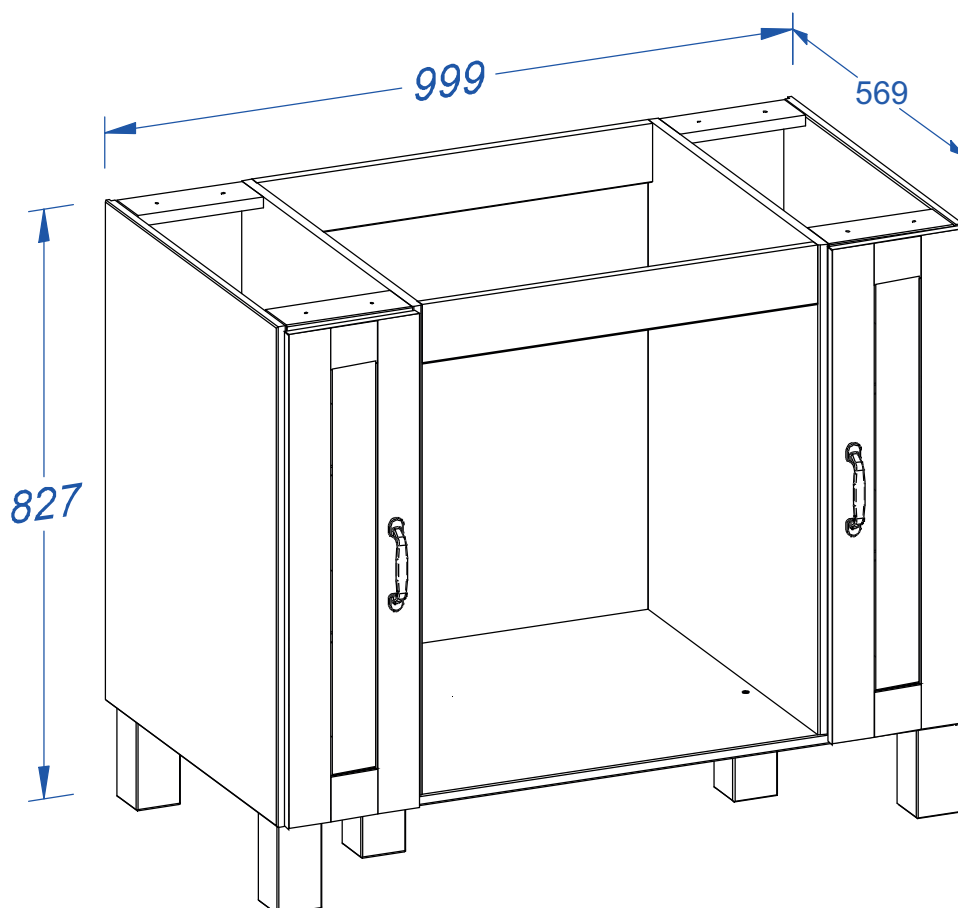

(D) *Montageanleitung*

(NL) *Handleiding voor de montage*

(TR) *Montaj talimatı*

(FR) *Notice de montage*

(CZ) *Montážní návod*

(HU) *Szerelési útmutató*

(GB) *Assembly instructions*

(PL) *Instrukcja montażu*

(RU) *Инструкция по монтажу*

(IT) *Istruzioni di montaggio*

(SK) *Návod na montáž*

(RO) *Instrucțiuni de montaj*



Name • Nom • Nome • Naam • Nazwa • Jméno •
 Názov • Név • Denumire • Isim • Название

Nr. • No. • N° • Номер • Č • Sz

Typ • Type • Tip • Tipus • Tipo • Тип

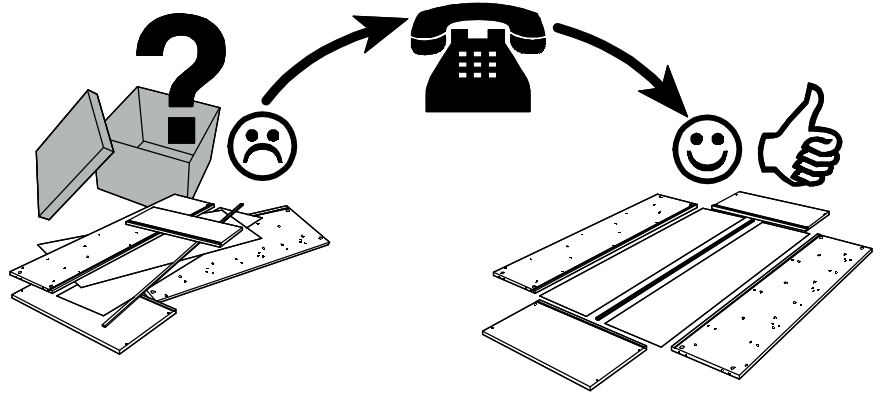
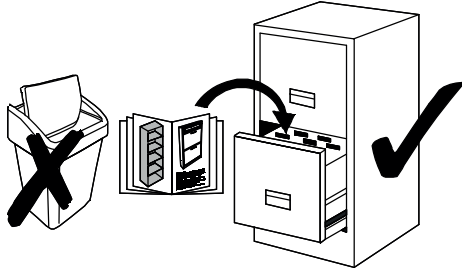



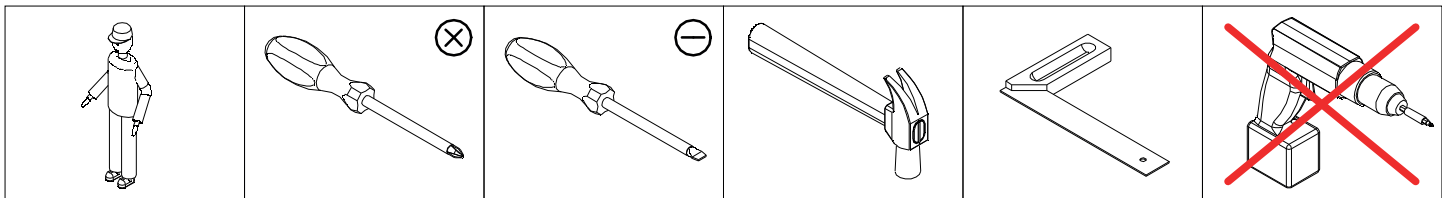

A10 22 x Ø8 x 35	E32 8 x Ø4,0 x 30	B52 12 x Ø7 x 50	C02 4 x fk.9	C20 4 x 2 mm	Dd 4 x M4 x 20
E17 8 x Ø3,5 x 15	F04 1 x 4 mm	F08 1 x 45 x 20 x 16	G02 18 x Ø15 x 11	G06 18 x L - 34	I01 50 x Ø1,2 x 20
N01 24 x Ø5 / Ø5	No 2 x 131 x 20				

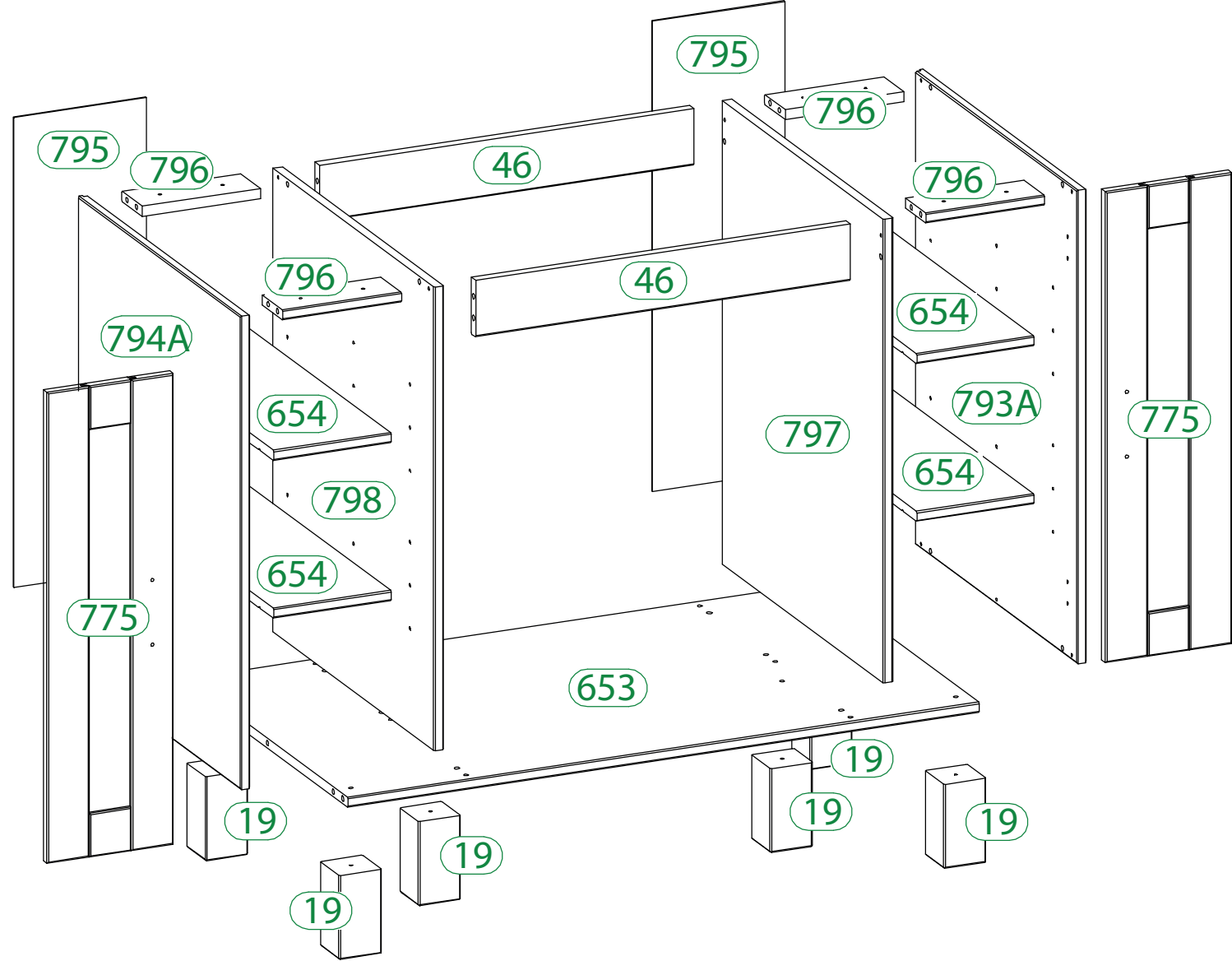

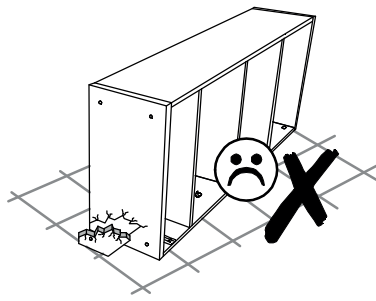
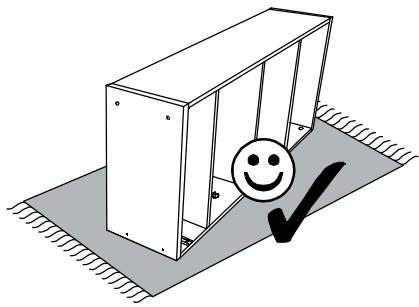
0 10 20 30 40 50 60 70 80 90 100 110 120 130 140 150 160 170 180 190



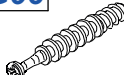

A10	6 x	G06	18 x	C20	4 x
			L - 34		2 mm
Ø8 x 35					

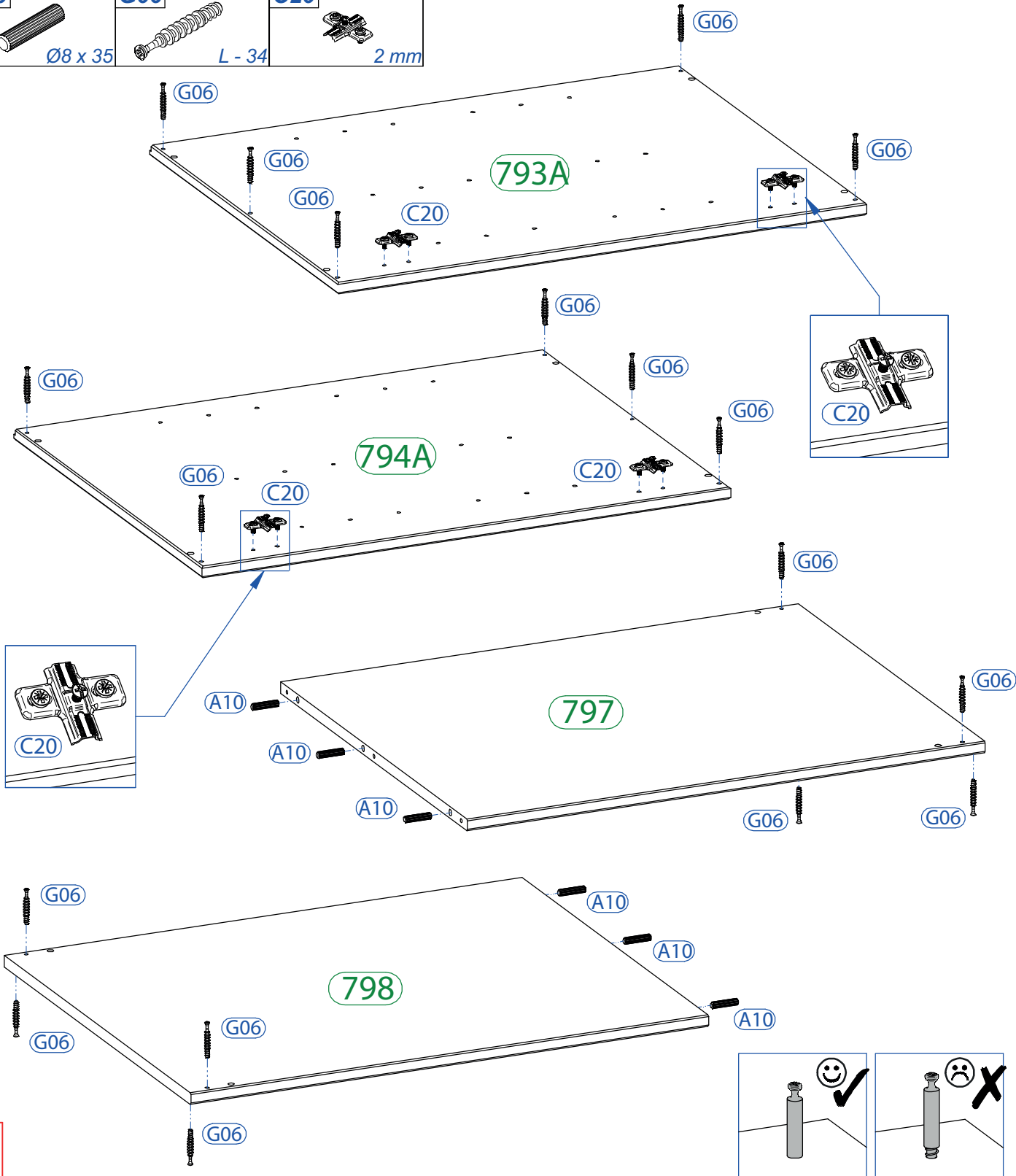

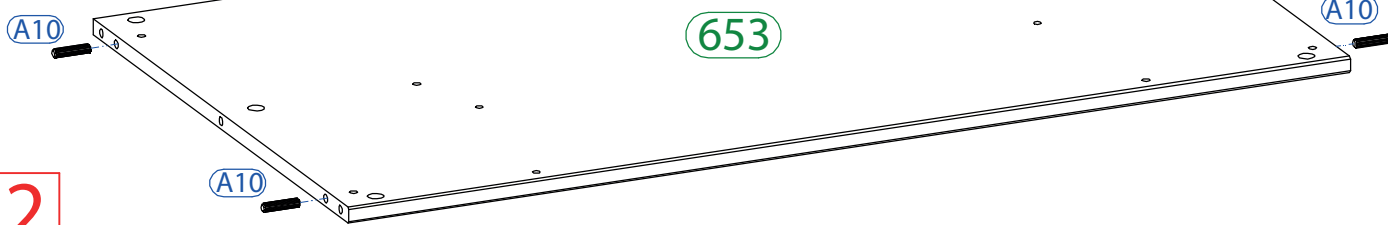
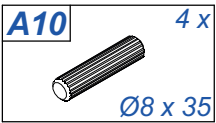

2

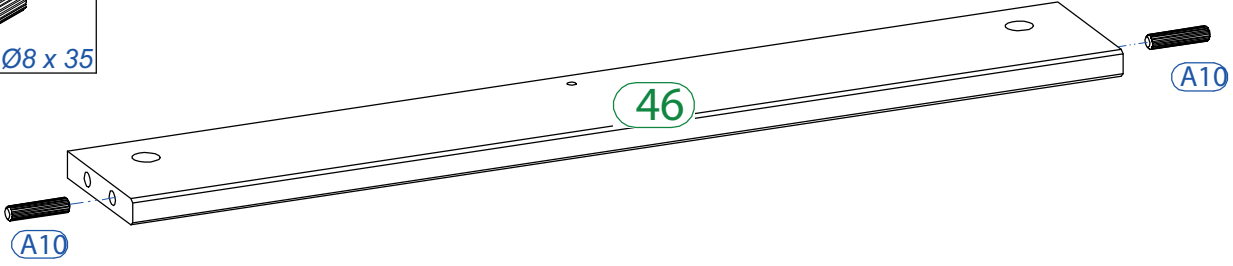
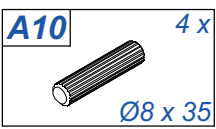

3 x 2

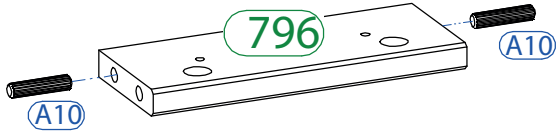
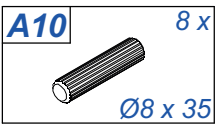

4 x 4

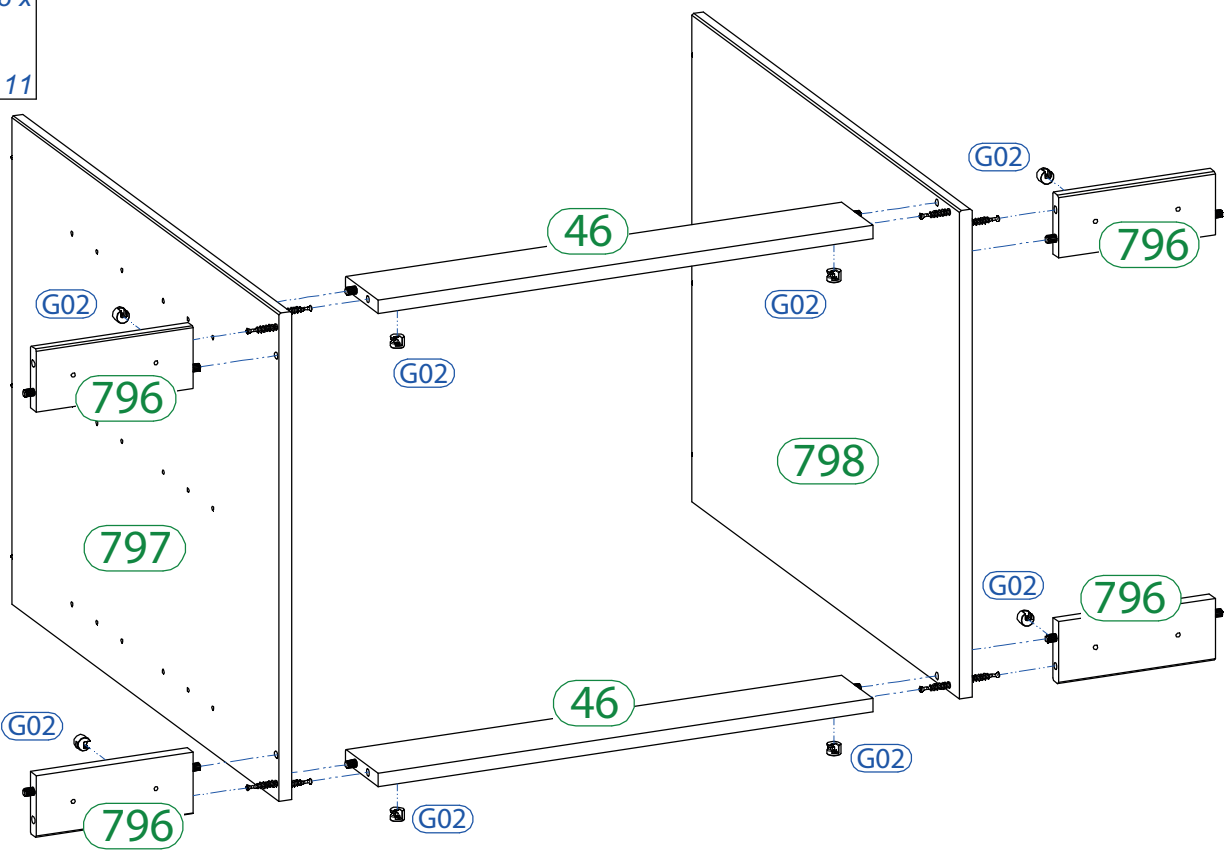
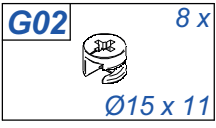

5

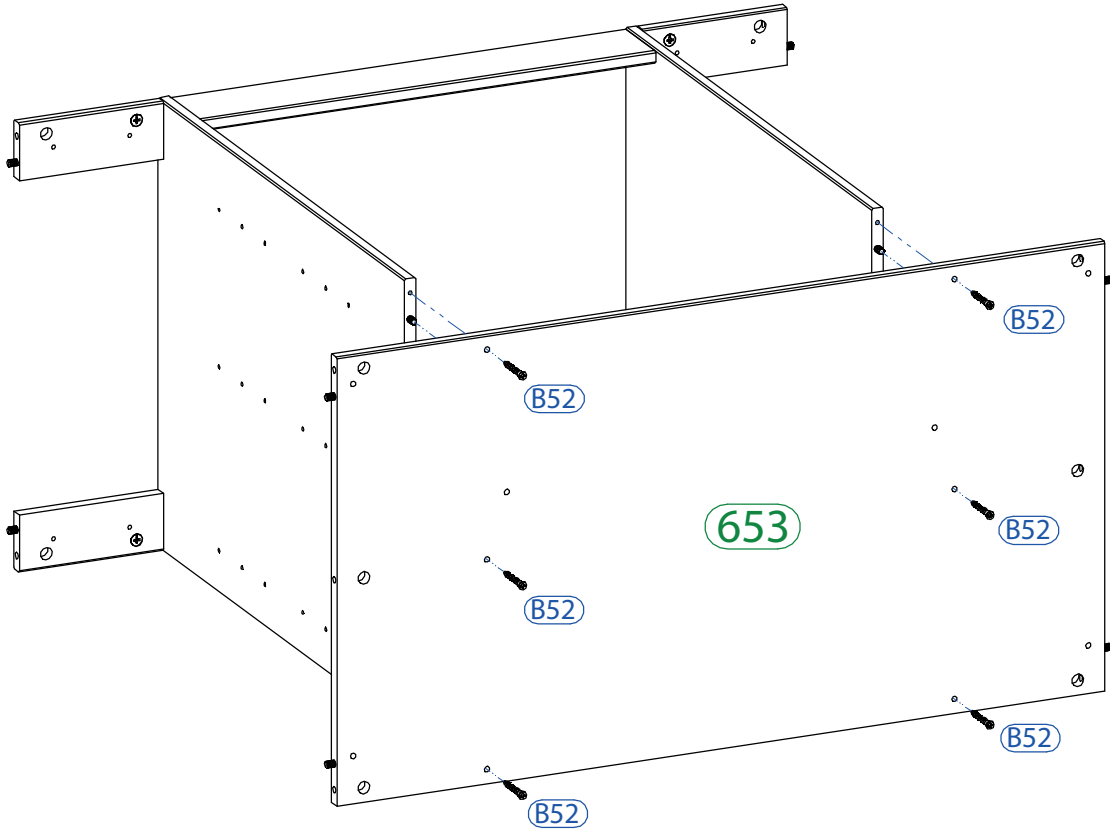
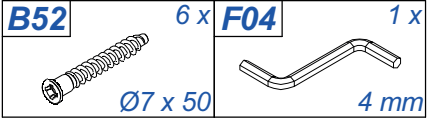

6

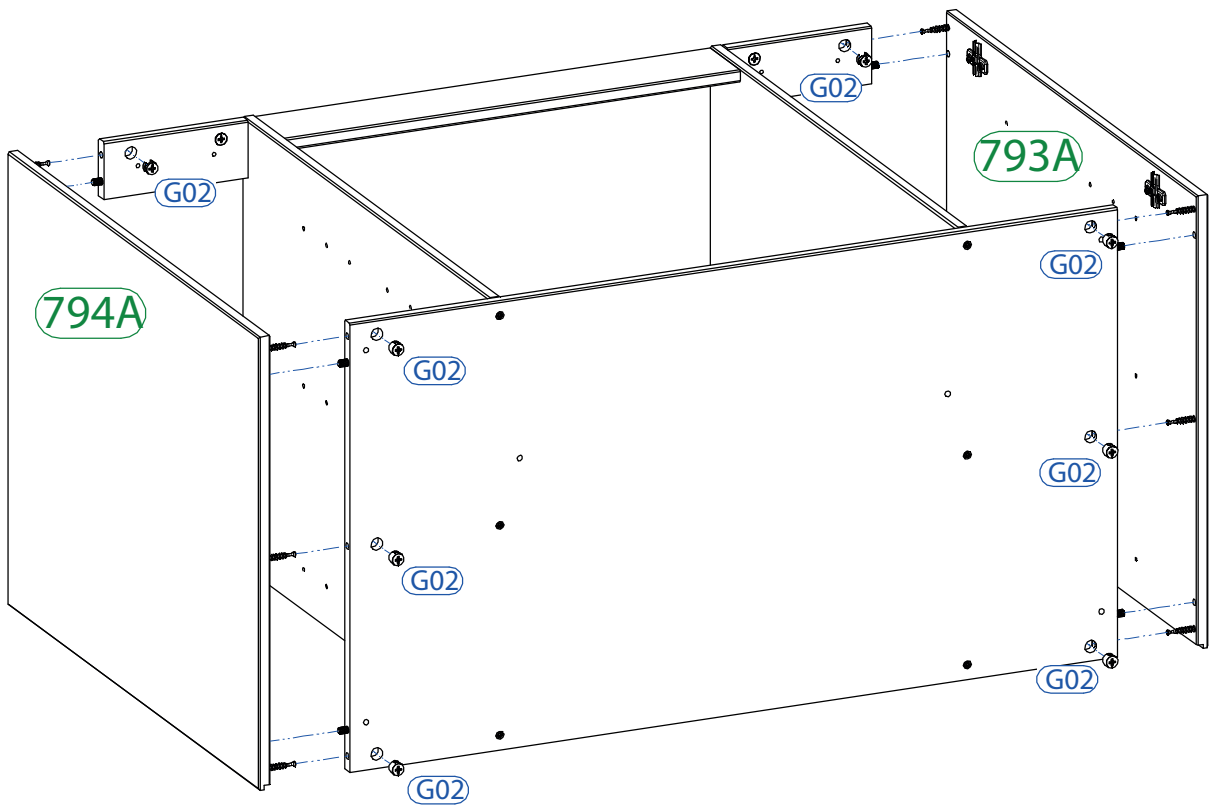
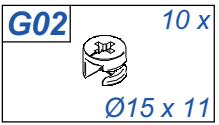

7

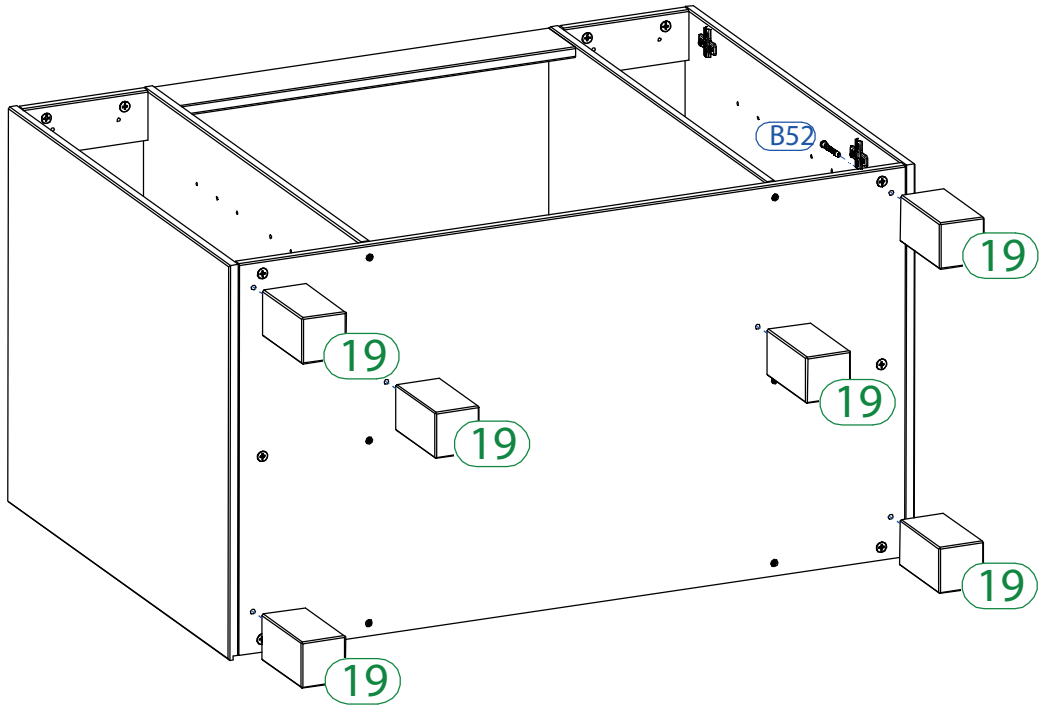
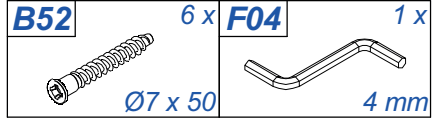

8

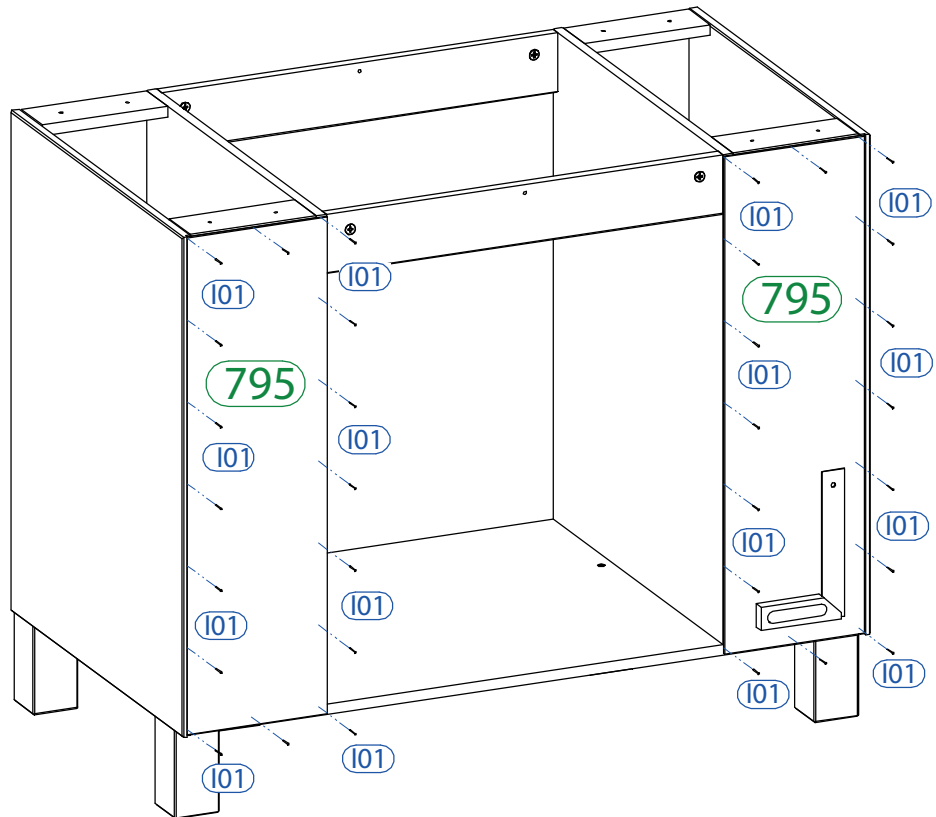
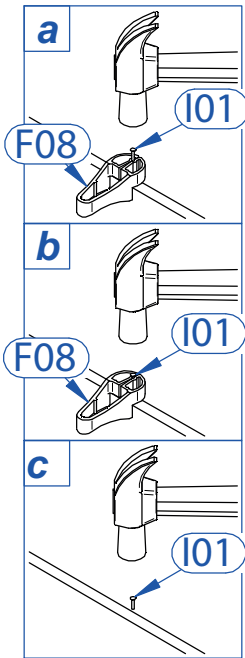
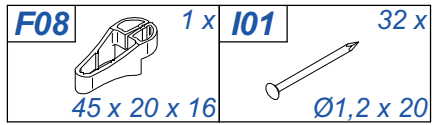

9

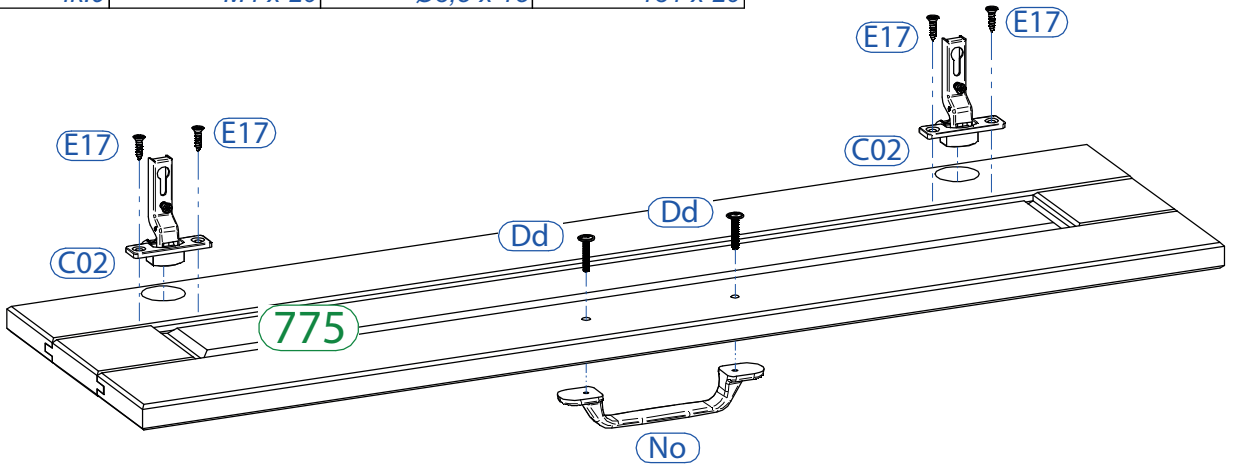
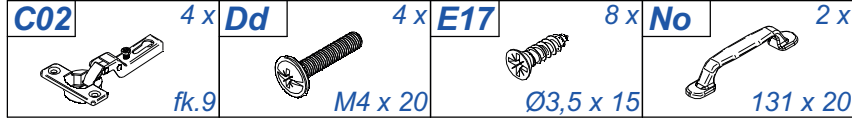

10x 2

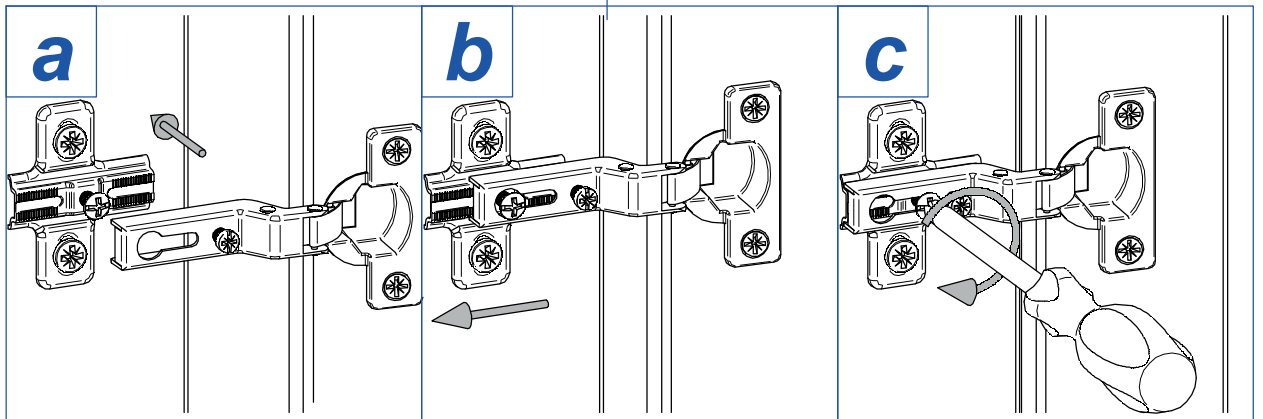
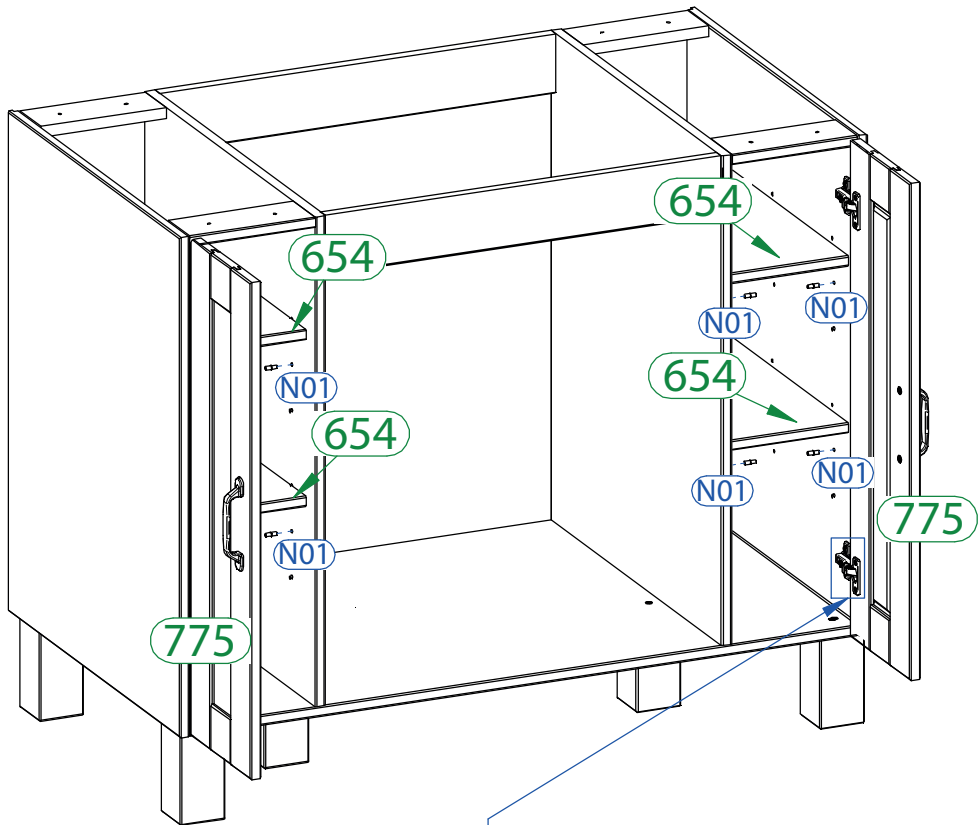
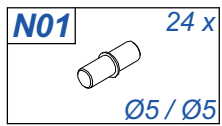

11

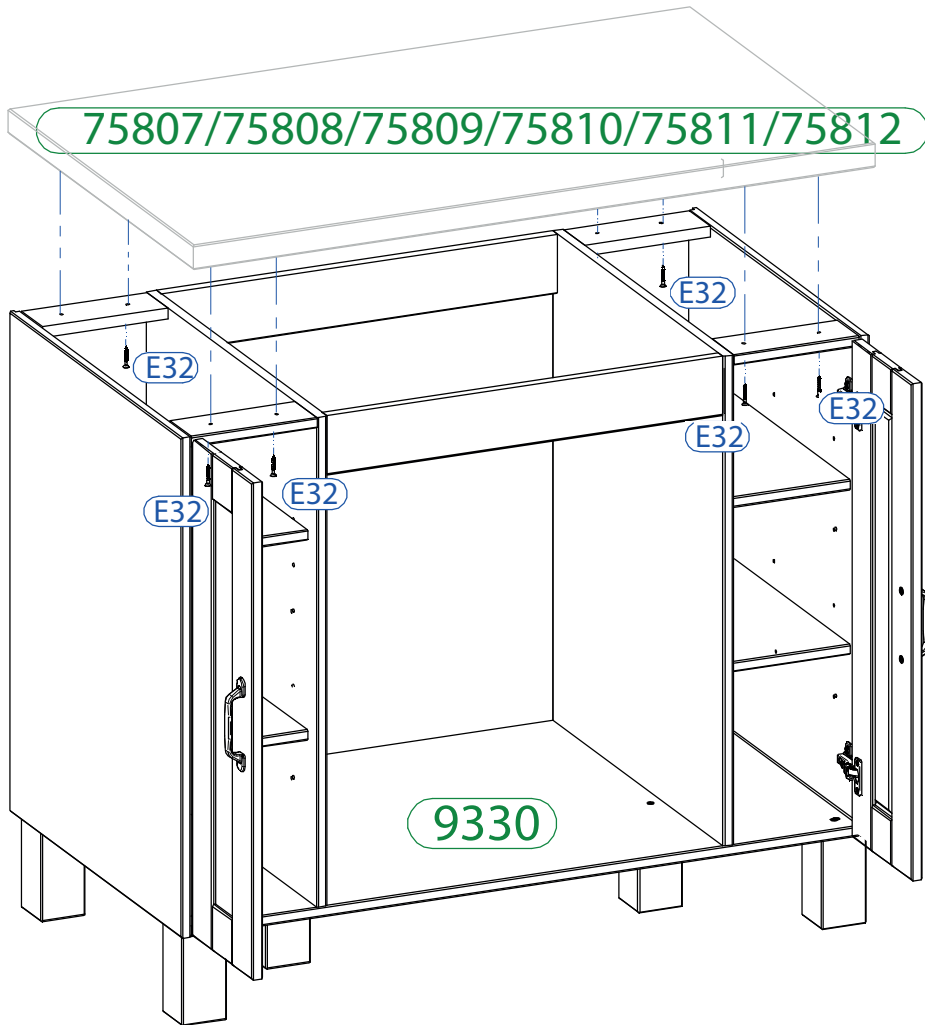
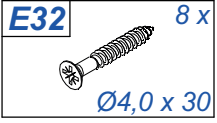



D	Türen einstellen (Scharniere justieren)
GB	Adjusting the doors (adjusting the hinges)
NL	Deuren instellen (scharnieren afstellen)
PL	Nastawić drzwi (wyrównać zawiasy)
TR	Kapıların ayarlanması (menteşelerin seviye ayarı)
RU	Регулировка дверей (регулировка шарнира)
FR	Régler les portes (ajuster les charnières)
IT	Sistemare le porte (regolare le cerniere)
CZ	Vyrovňte dvířka (seřďte závěsy)
SK	Nastavenie dverí (nastavenie závesov)
HU	Állítsa be az ajtókat (állítsa be a zsanérokot)
RO	Reglare ușii (ajustare balamale)

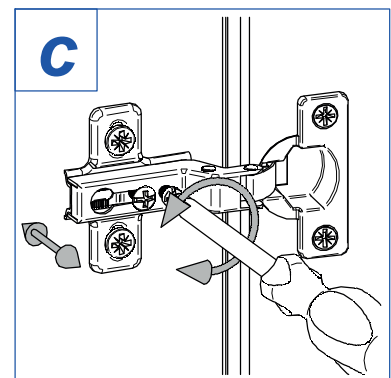
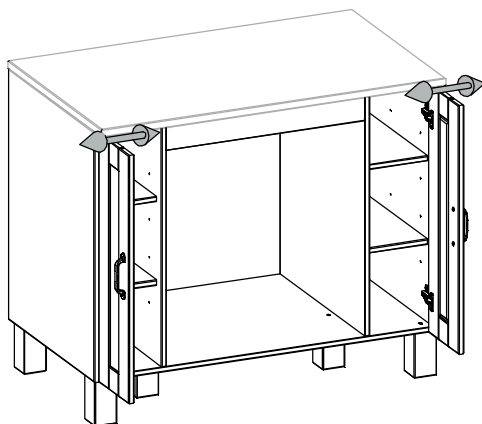
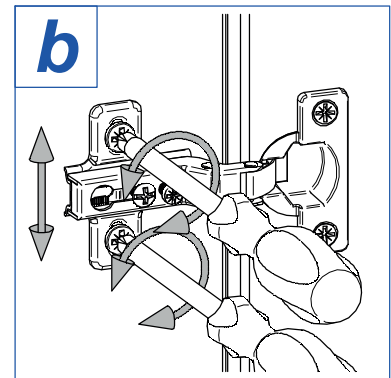
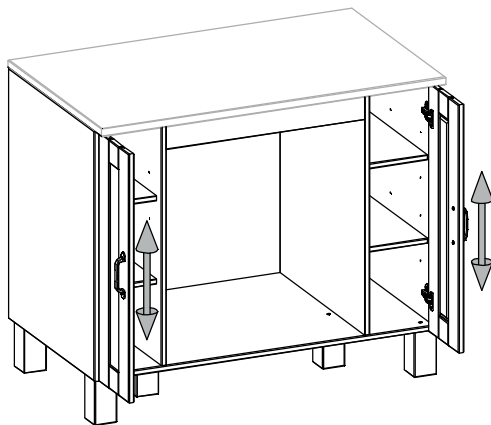
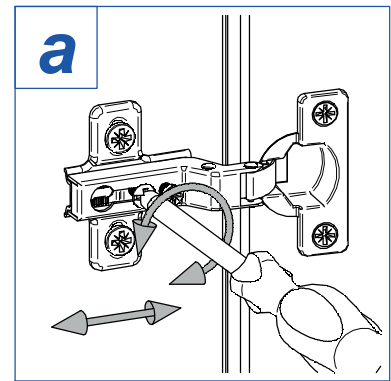
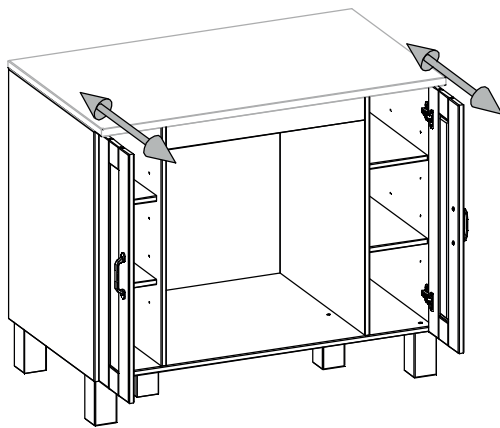

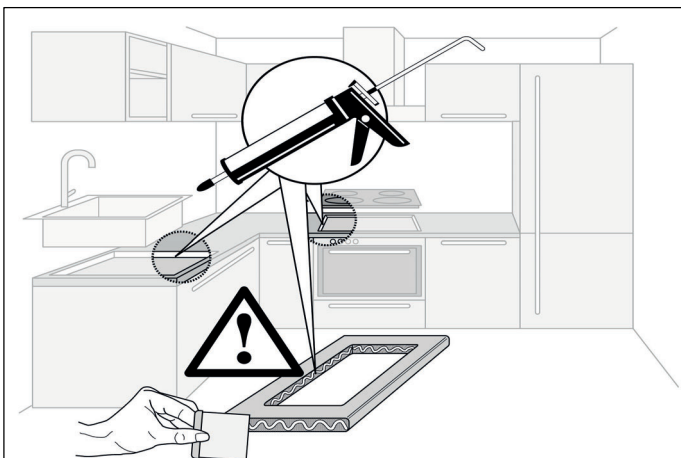
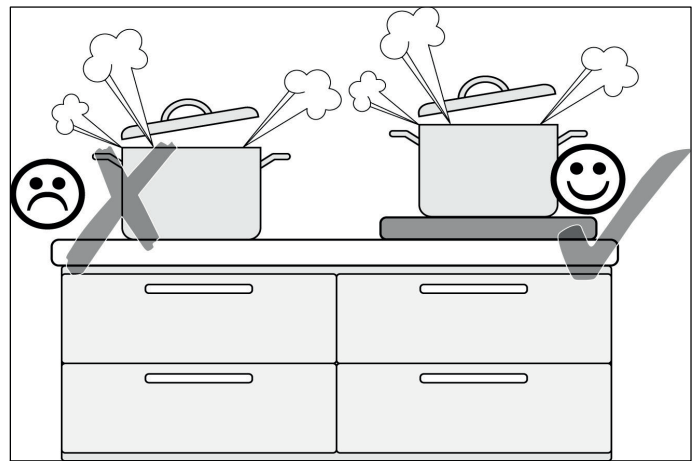
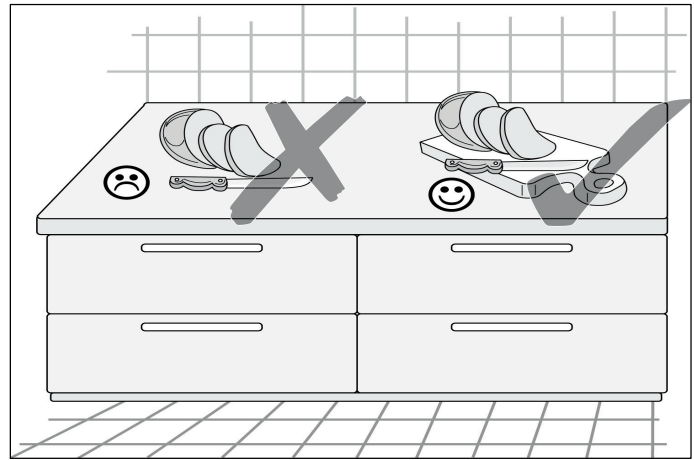
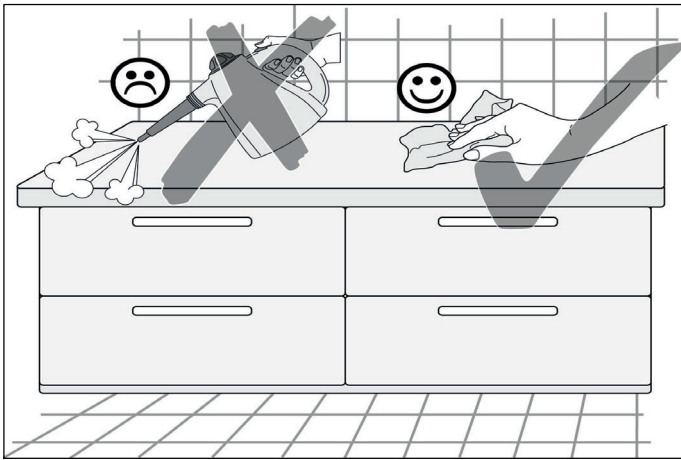
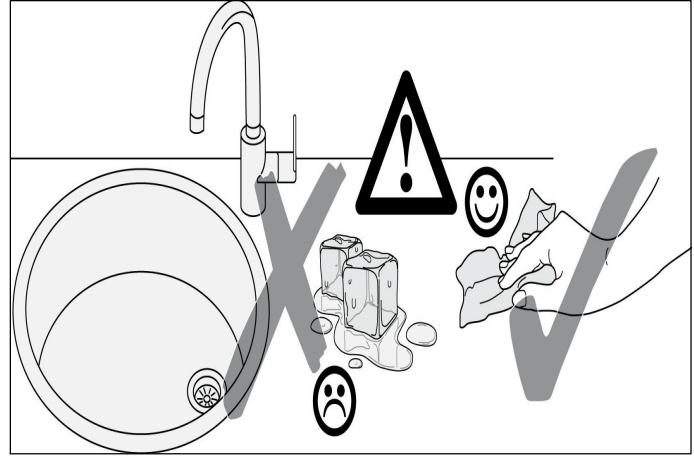
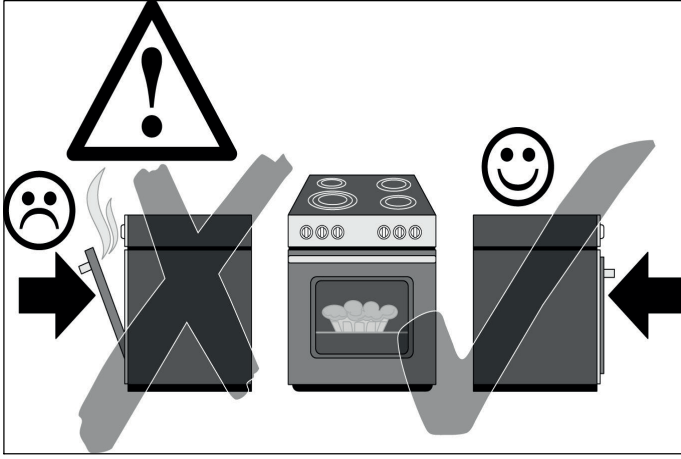

»75807 / 75808 / 75809 / 75810 / 75811 / 75812«

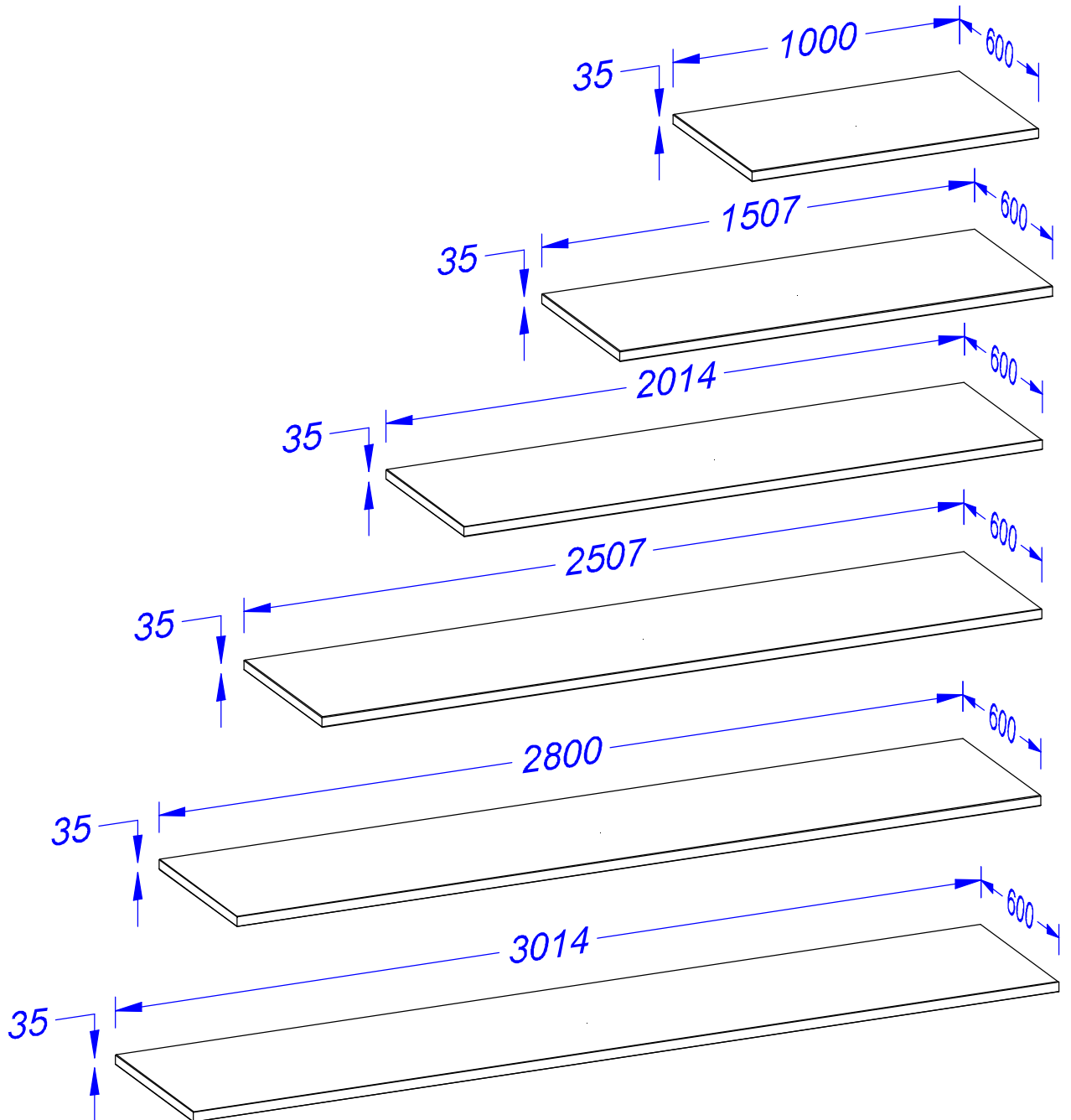

(D) *Montageanleitung*

(NL) *Handleiding voor de montage*

(TR) *Montaj talimatı*

(FR) *Notice de montage*

(CZ) *Montážní návod*

(HU) *Szerelési útmutató*

(GB) *Assembly instructions*

(PL) *Instrukcja montażu*

(RU) *Инструкция по монтажу*

(IT) *Istruzioni di montaggio*

(SK) *Návod na montáž*

(RO) *Instrucțiuni de montaj*

Name • Nom • Nome • Naam • Nazwa • Jméno •
Názov • Név • Denimire • Isim • Название

Nr. • No. • N° • Номер • Č • Sz

Typ • Type • Tip • Tipus • Tipo • Тип

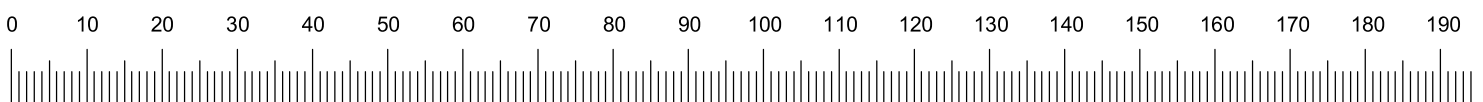
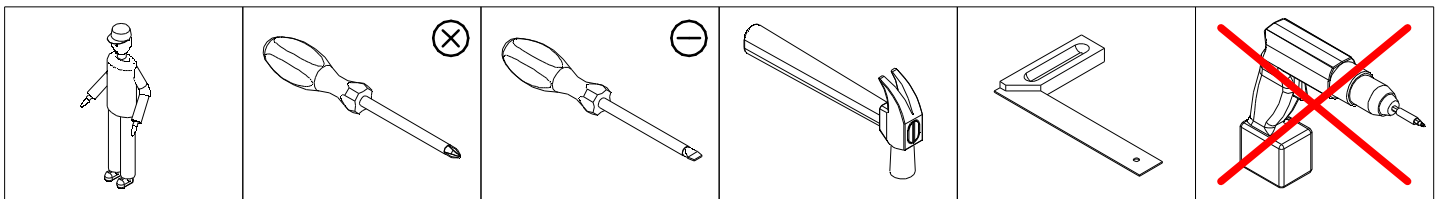
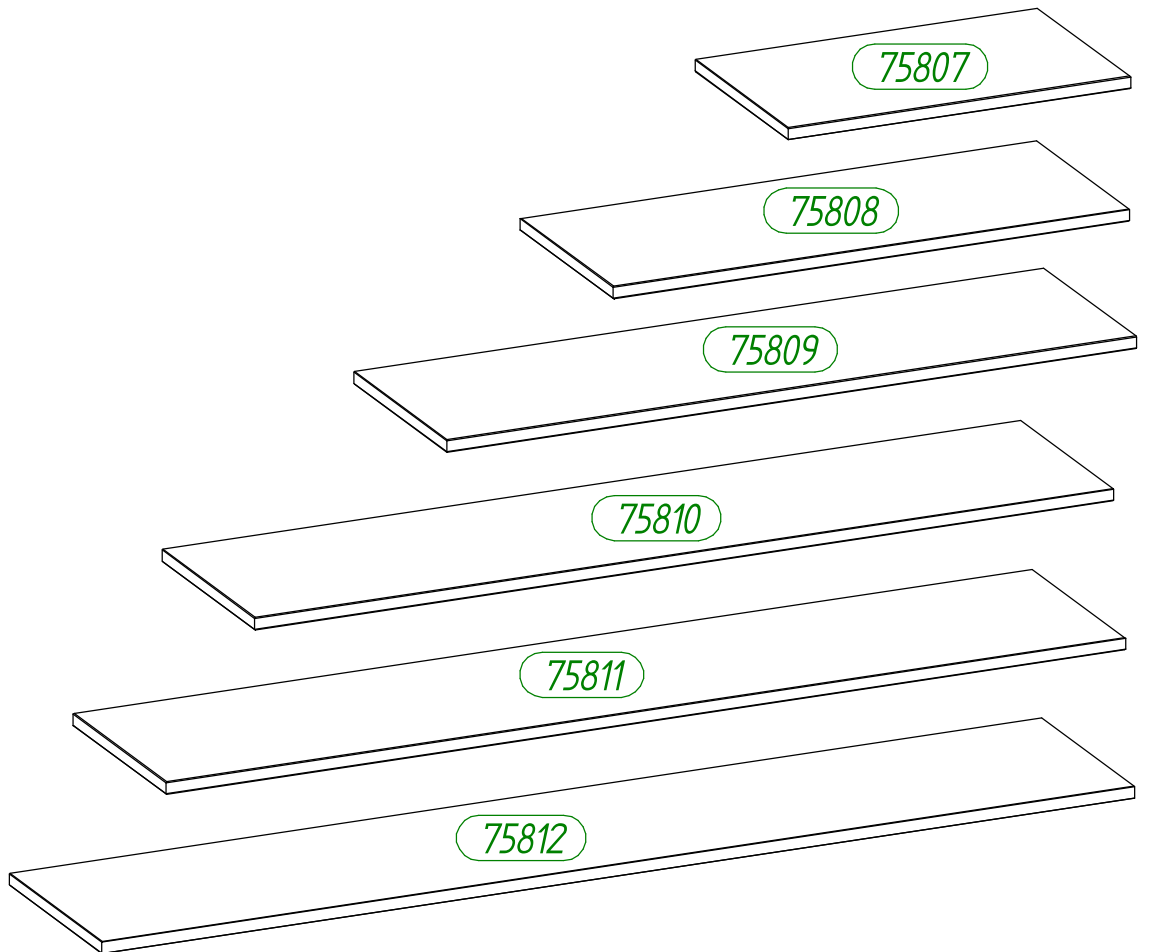
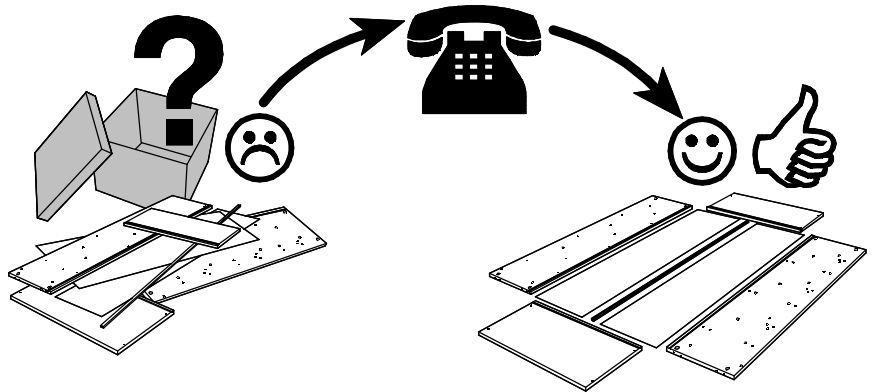
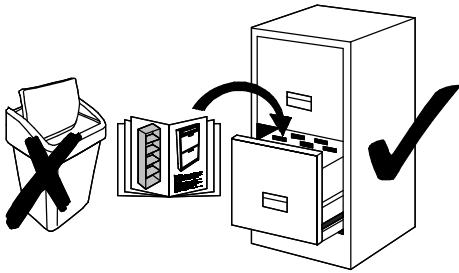



Achtung • Attention • Attenzione • Opgelet • Uwaga • Pozor • Figyelem • Atenție •
Dikkat • Внимание

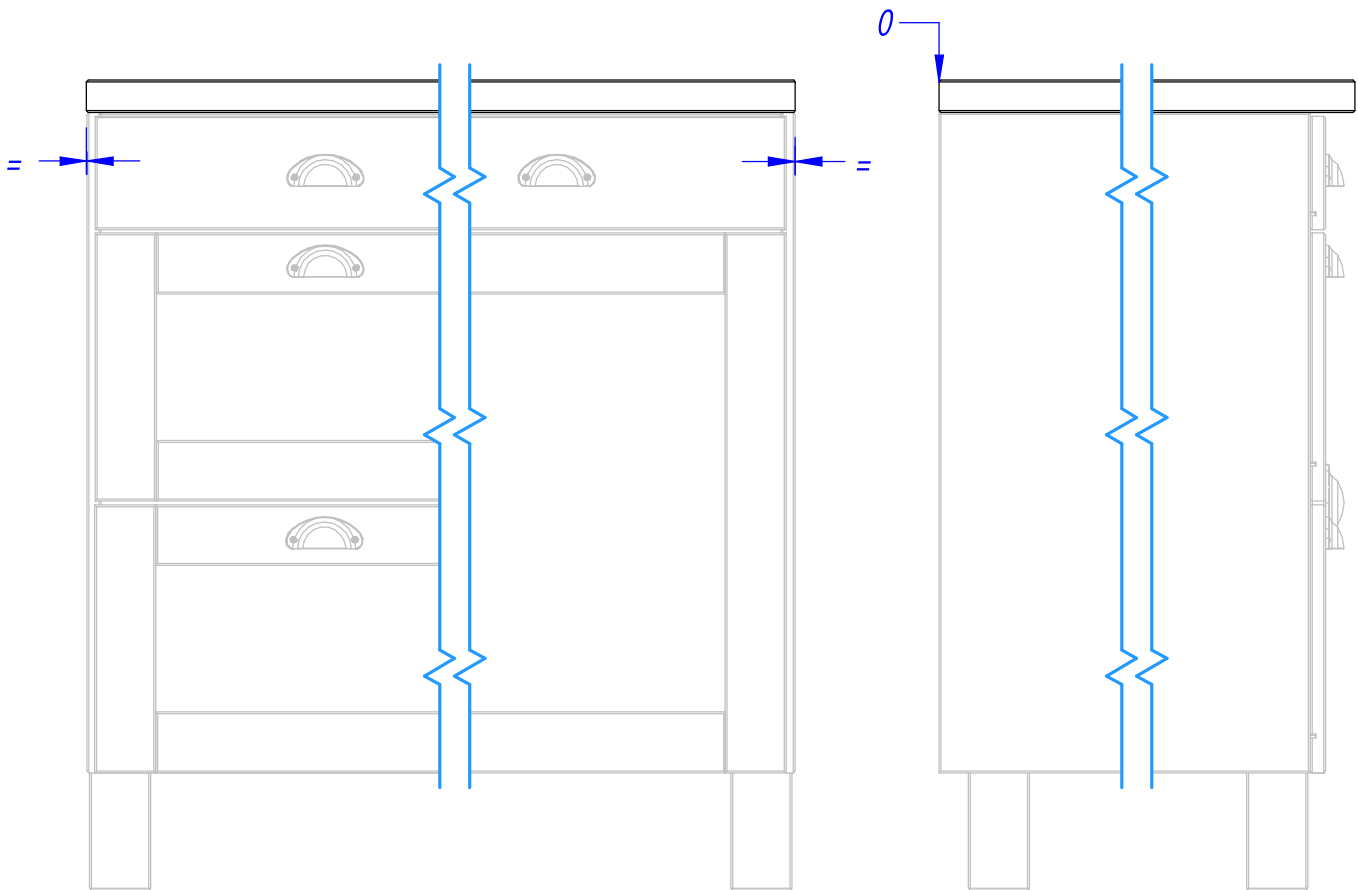
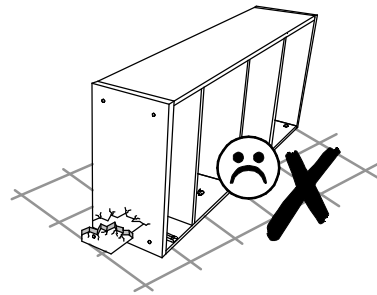
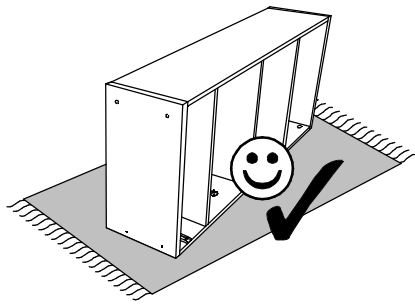

1