

Installation sanleitung Installation Instruction Instruction d'installation

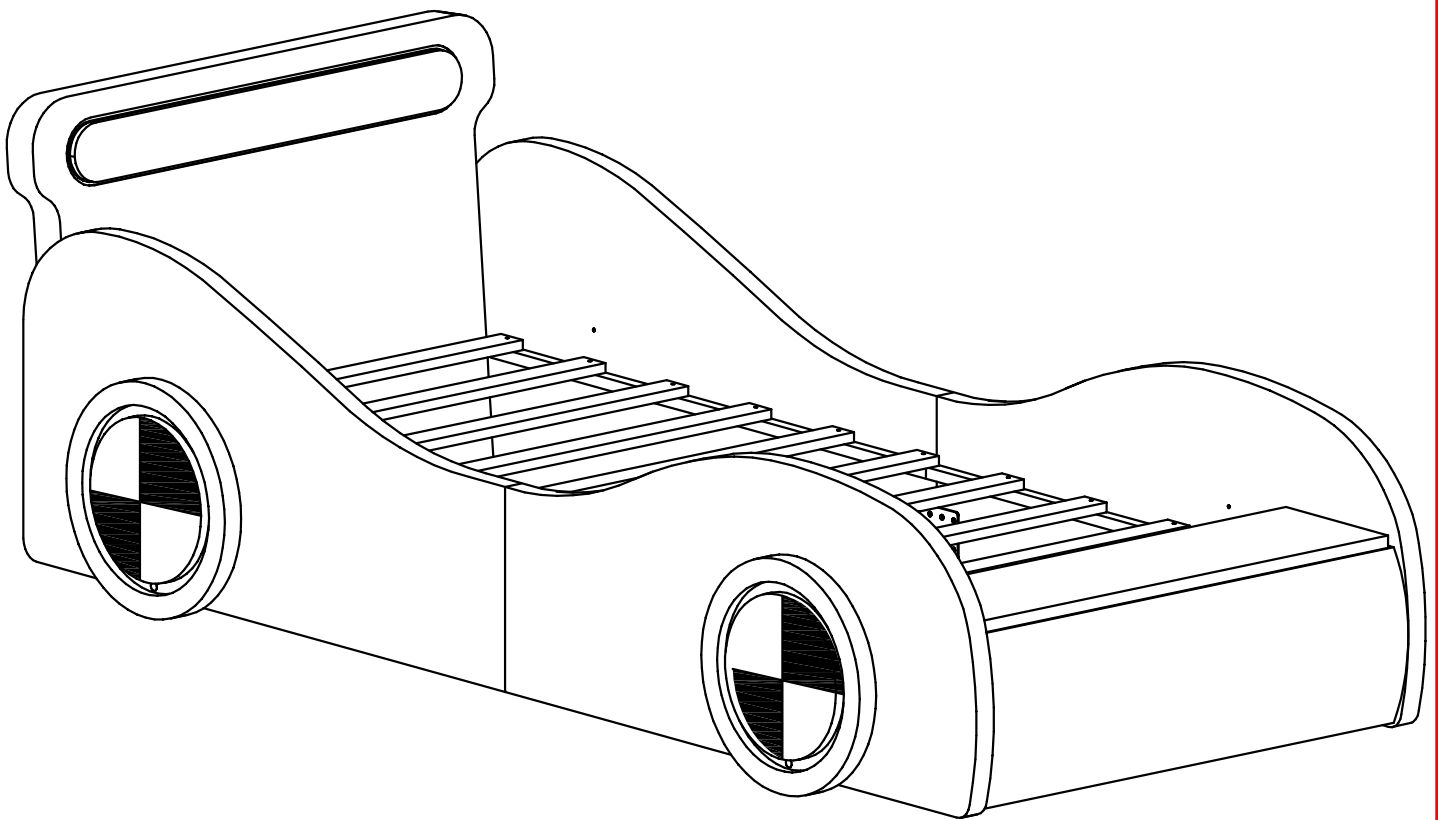

Unser Produkt wird Ihnen in **3** Paketen geliefert. Die Lieferzeiten dieser **3** Pakete können abweichen, bitte haben Sie etwas Geduld und vielen Dank für Ihr Verständnis.

Our product will be delivered to you in **3** packages. The delivery times of these **3** packages may differ, please be patient and thank you for your understanding.

Notre produit vous sera livré en **3** colis. Les délais de livraison de ces **3** colis peuvent différer, soyez patient et merci pour votre compréhension.

SKU CODE: (N636P199155-N636P199156-N636P199157)

English IMPORTANT ! KEEP FOR FUTURE REFERENCE : READ CAREFULLY

- To be assembled by an adult. Assembly must be checked by an adult before use
- WARNING ! Keep all screws, small parts and plastic bags out of the reach of children
- Properly identify all parts before assembling
- Never use your item if any of its parts are broken or missing
- Should any problems arise, please contact our After Sales Service
- Manufacturer's instructions shall be followed at all times
- Care: Clean with a soft, dry cloth. In case of larger stains, carefully rub with a slightly damp, non-abrasive sponge
- Avoid the risk of fire by not placing furniture near sources of ignition or hot items
- Do not jump on the bed

Deutsch WICHTIG ! ZUM SPÄTEREN NACHSCHLAGEN AUFBEWAHREN: SORGFÄLTIG LESEN

- Muss von einem Erwachsenen zusammengebaut werden. Der Zusammenbau muss vor dem Gebrauch von einem Erwachsenen überprüft werden
- WARNUNG! Bewahren Sie alle Schrauben, Kleinteile und Plastikbeutel außerhalb der Reichweite von Kindern auf
- Kennzeichnen Sie vor dem Zusammenbau alle Teile richtig
- Benutzen Sie Ihren Artikel niemals, wenn Teile gebrochen sind oder fehlen
- Sollten Probleme auftreten, wenden Sie sich bitte an unseren Kundendienst
- Die Anweisungen des Herstellers sind stets zu befolgen
- Pflege: Mit einem weichen, trockenen Tuch reinigen. Bei größeren Flecken vorsichtig mit einem leicht feuchten, nicht scheuernden Schwamm abreiben. nicht scheuernden Schwamm
- Vermeiden Sie die Gefahr eines Brandes, indem Sie die Möbel nicht in der Nähe von Zündquellen oder heißen Gegenständen aufstellen
- Nicht auf das Bett springen

Français IMPORTANT ! CONSERVER POUR RÉFÉRENCE ULTÉRIEURE : LIRE ATTENTIVEMENT

- Le montage doit être effectué par un adulte. Le montage doit être vérifié par un adulte avant Utilisation
- ATTENTION ! Tenir les vis, les petites pièces et les sachets en plastique hors de portée des enfants
- Identifiez correctement toutes les pièces avant de les assembler
- N'utilisez jamais votre article si l'une de ses pièces est cassée ou manquante
- En cas de problème, veuillez contacter notre service après-vente
- Les instructions du fabricant doivent être respectées à tout moment
- Entretien : nettoyer avec un chiffon doux et sec. En cas de taches plus importantes, frotter soigneusement avec une éponge non abrasive légèrement humide. légèrement humide et non Abrasive
- Évitez les risques d'incendie en ne plaçant pas les meubles à proximité de sources d'inflammation ou d'objets chauds
- Ne pas sauter sur le lit

Italiano **IMPORTANTE!** CONSERVARE PER RIFERIMENTO FUTURO: LEGGERE ATTENTAMENTE

- Deve essere assemblato da un adulto. L'assemblaggio deve essere controllato da un adulto prima dell'uso
- ATTENZIONE! Tenere tutte le viti, le piccole parti e i sacchetti di plastica fuori dalla portata dei bambini
- Identificare correttamente tutte le parti prima dell'assemblaggio
- Non utilizzare mai l'articolo se alcune parti sono rotte o mancanti
- In caso di problemi, si prega di contattare il nostro Servizio Post Vendita
- Le istruzioni del produttore devono essere sempre seguite
- Cura: Pulire con un panno morbido e asciutto. In caso di macchie più estese, strofinare accuratamente con una spugna leggermente umida e nonspugna leggermente umida e non abrasiva
- Evitare il rischio di incendio, non collocando i mobili vicino a fonti di accensione o a oggetti caldi
- Non saltare sul letto

Español ¡**IMPORTANTE !** CONSÉRVELO PARA FUTURAS CONSULTAS: LEA ATENTAMENTE

- Debe ser montado por un adulto. El montaje debe ser comprobado por un adulto antes del uso
- ADVERTENCIA Mantenga todos los tornillos, piezas pequeñas y bolsas de plástico fuera del alcance de los niños.
- Identifique correctamente todas las piezas antes de montarlas
- Nunca utilice su artículo si alguna de sus piezas está rota o falta
- Si surge algún problema, póngase en contacto con nuestro Servicio Postventa
- Las instrucciones del fabricante deben seguirse en todo momento
- Cuidado: Limpiar con un paño suave y seco. En caso de manchas más grandes, frote cuidadosamente con una esponja no abrasiva ligeramente humedecida.
- Evite el riesgo de incendio no colocando los muebles cerca de fuentes de ignición u objetos calientes.
- No saltar sobre la cama.

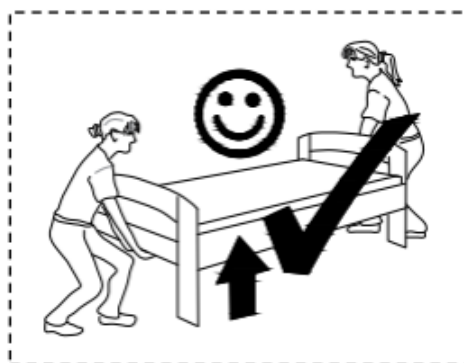
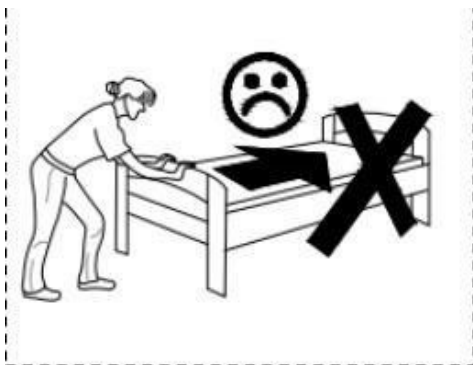

Vor dem Einbau die Schrauben in die Löcher stecken und festziehen, aber nicht bis 100%, 70% bis 80% anziehen reicht aus. Schließlich, nachdem alle Schrauben installiert sind, ziehen Sie alle Schrauben auf 100%.

Wenn Sie auf diese Probleme stoßen, wie z. B. Fehlausrichtung der Löcher oder Unfähigkeit, bestimmte Teile zu installieren, überprüfen Sie bitte, ob die Schrauben korrekt verwendet werden und passen Sie die Dichtigkeit der Schrauben an.

Before installation, insert the screws into the holes and tighten them, but do not tighten them to 100%, 70% to 80% is sufficient. Finally, after all screws are installed, tighten all screws to 100%.

If you encounter these issues, such as if the holes cannot be aligned or some parts cannot be installed, please check if the screws are used correctly and adjust the tightness of the screws.

Insérer la vis dans le trou avant la fin de l'assemblage, serrer la vis, mais ne pas serrer à 100%, 70% ~ 80% est correct. Enfin, une fois que toutes les vis sont bien serrées, toutes les vis sont serrées à 100%.

Si vous rencontrez ces problèmes, par exemple si les trous ne sont pas alignés ou si certaines pièces ne peuvent pas être montées, vérifiez que les vis sont utilisées correctement et Ajustez leur serrage.

BAUANLEITUNG

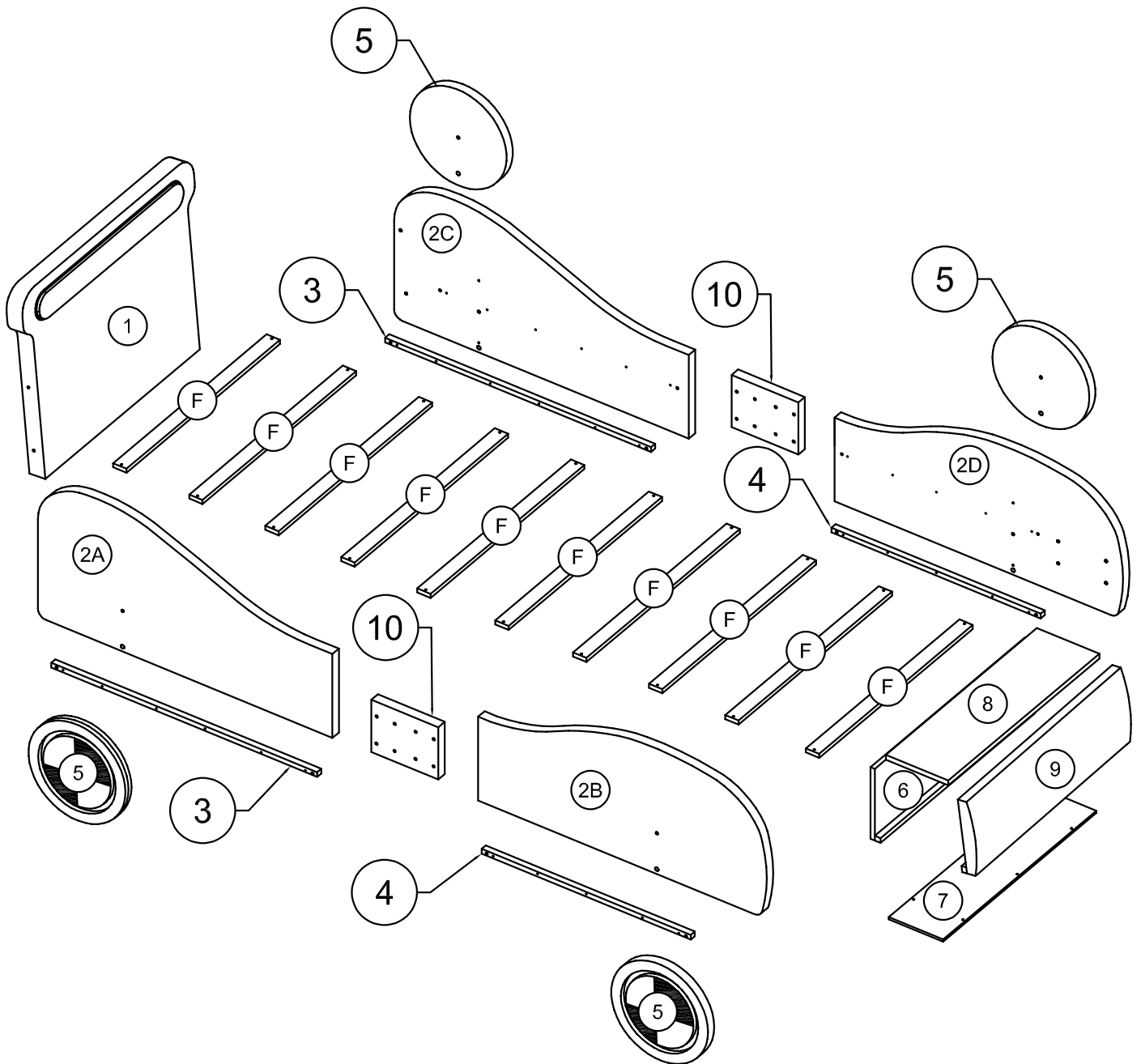

Stückliste (N636P199155)

1

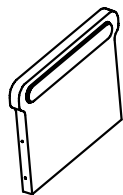

Kopfteil - 1Stk

5



Seitenschiene - 4Stk

10

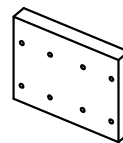

Querstange - 2Stk

Stückliste (N636P199156)

2B

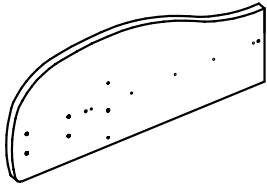

Seitenschiene - 1Stk

2D

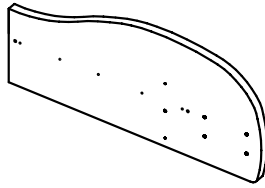

Seitenschiene - 1Stk

F

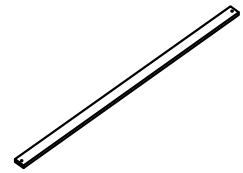

Lamellen - 4Stk

6

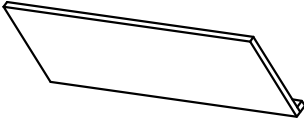

Trittbrett -1Stk

9

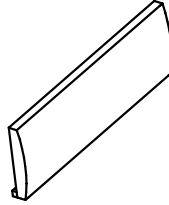

Trittbrett -1Stk

Stückliste (N636P199157)

2A

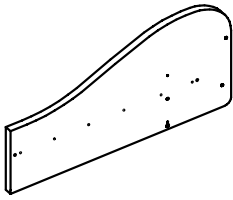

Seitenschienen - 1Stk

2C

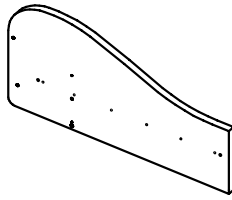

Seitenschienen - 1Stk

3

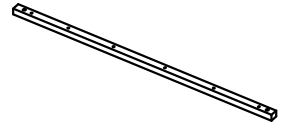

Barunterstützung - 2Stk

4

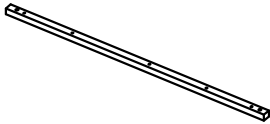

Barunterstützung - 2Stk

7

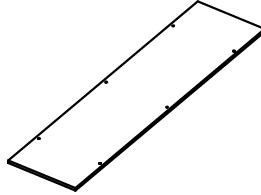

Querstange - 1Stk

8

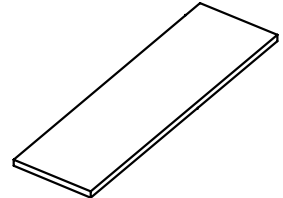





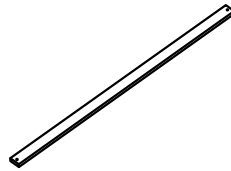



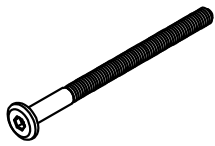
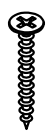

Querstange - 1Stk

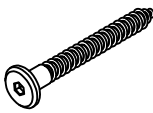
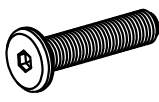
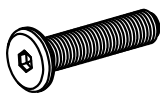
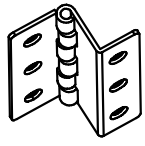
F

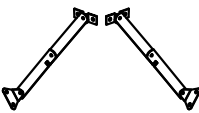

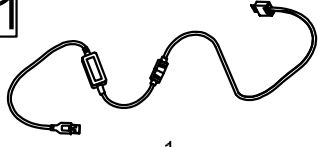
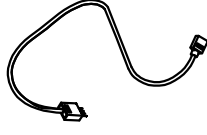
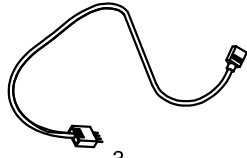
Lamellen - 6Stk

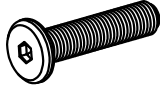
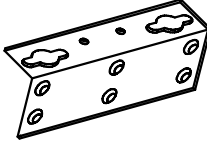
Hardwareliste (N636P199157)

<p>A</p>  <p>1/4" x 80 mm Sechskantschrauben 4Stk</p>	<p>B</p>  <p>#4 x 70 mm Holzschrauben 8Stk</p>	<p>C</p>  <p>#4 x 20 mm Holzschrauben 54Stk</p>
<p>D</p>  <p>Ø1/4" x 50 mm Wood Screws 16Stk</p>	<p>E</p>  <p>1/4" x 50 mm Sechskantschrauben 4Stk</p>	<p>G</p>  <p>1/4" x 30 mm Sechskantschrauben 8Stk</p>
<p>H</p>  <p>Scharnier 60mm 2Stk</p>	<p>I</p>  <p>#4 x 30 mm Holzschrauben 20Stk</p>	<p>K</p>  <p>Kurbelwelle 1 Satz (1L-1R)</p>
<p>L</p>  <p>1 2 Festsitzende Zahnspanne 30Stk</p>	<p>M-1</p>  <p>1 Draht 1000mm 1Stk</p>	<p>M-2</p>  <p>2 Draht 1650mm 2Stk</p>
<p>M-3</p>  <p>3 Draht 1350mm 1Stk</p>	<p>N</p>  <p>Inbusschlüssel 1Stk</p>	<p>S</p>  <p>1/4" x 40 mm Sechskantschrauben 8Stk</p>
<p>P</p>  <p>Eisenplatte 4Stk</p>	<p>T</p>  <p>#4 x 50 mm Holzschrauben 22Stk</p>	

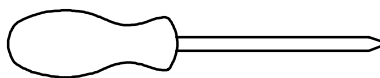

Montagewerkzeuge erforderlich (nicht im Lieferumfang enthalten)

Hardwareliste (N636P199157)

B

#4 x 70 mm Holzschrauben 8Stk

I

#4 x 30 mm Holzschrauben 20 Stk

T

#4 x 50 mm Holzschrauben 22Stk

Bitte beachten Sie, dass die Formen der Schrauben B und I, T ähnlich sind. Bitte installieren Sie entsprechend der Anleitung und unterscheiden Sie sie!

Please note that the shapes of screws B und I, T are similar. Please install according to the instructions and distinguish them!

Notez que les vis B und I, T ont des formes similaires. Veuillez les installer en suivant les instructions pour les séparer!

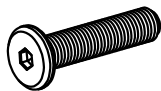
E

1/4" x 50 mm Sechskantschrauben 4Stk

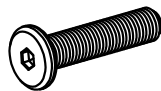
G

1/4" x 30 mm Sechskantschrauben 8Stk

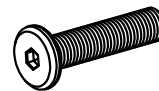
S

1/4" x 40 mm Sechskantschrauben 8Stk

Bitte beachten Sie, dass die Formen der Schrauben E und G, S ähnlich sind. Bitte installieren Sie entsprechend der Anleitung und unterscheiden Sie sie!

Please note that the shapes of screws E und G, S are similar. Please install according to the instructions and distinguish them!



Notez que les vis E und G, S ont des formes similaires. Veuillez les installer en suivant les instructions pour les séparer!

SCHRITT 1: Nachfolgende Abbildung:

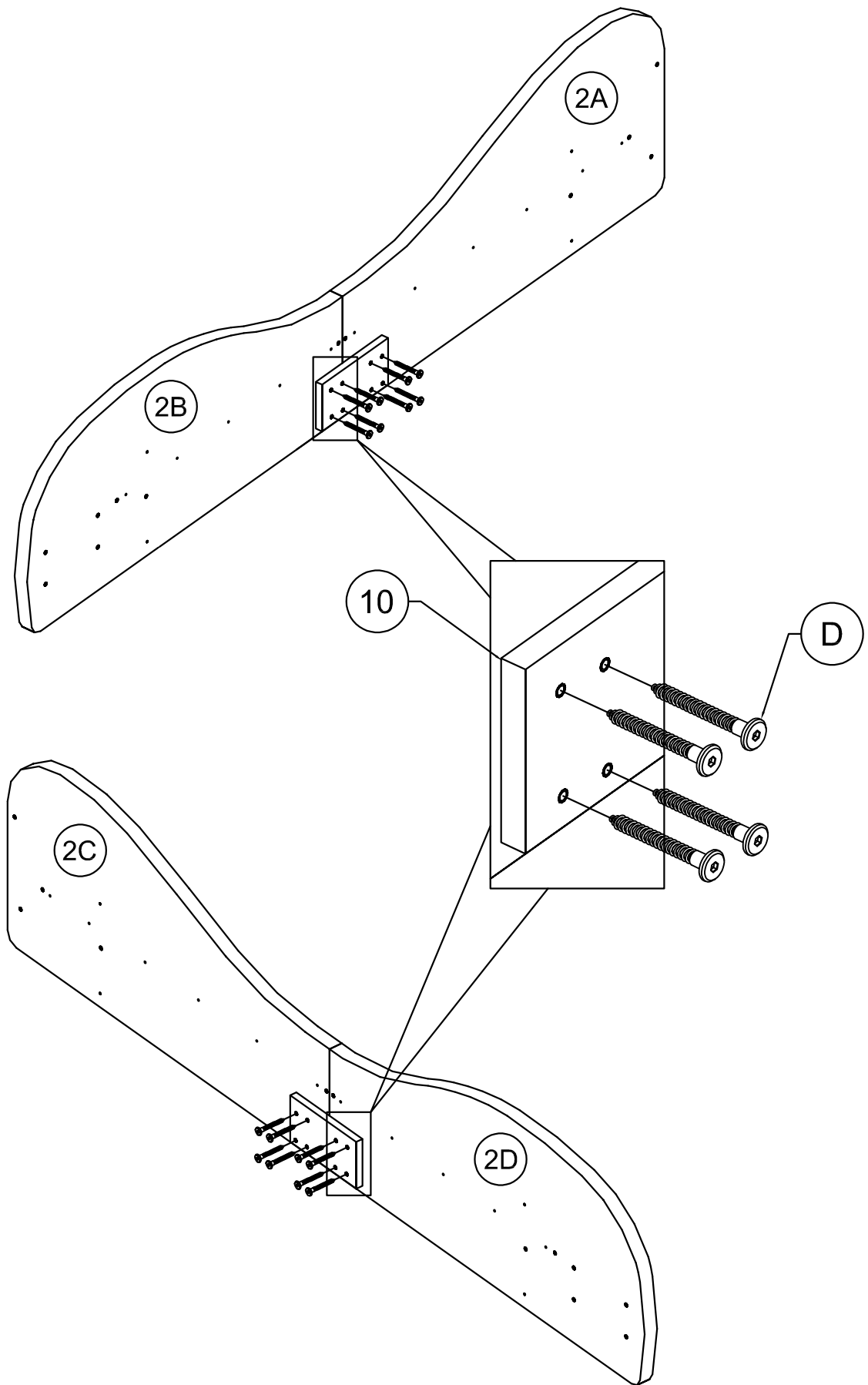
D

16stk



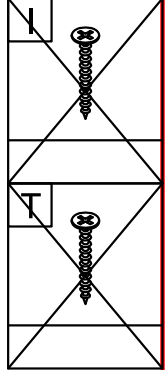

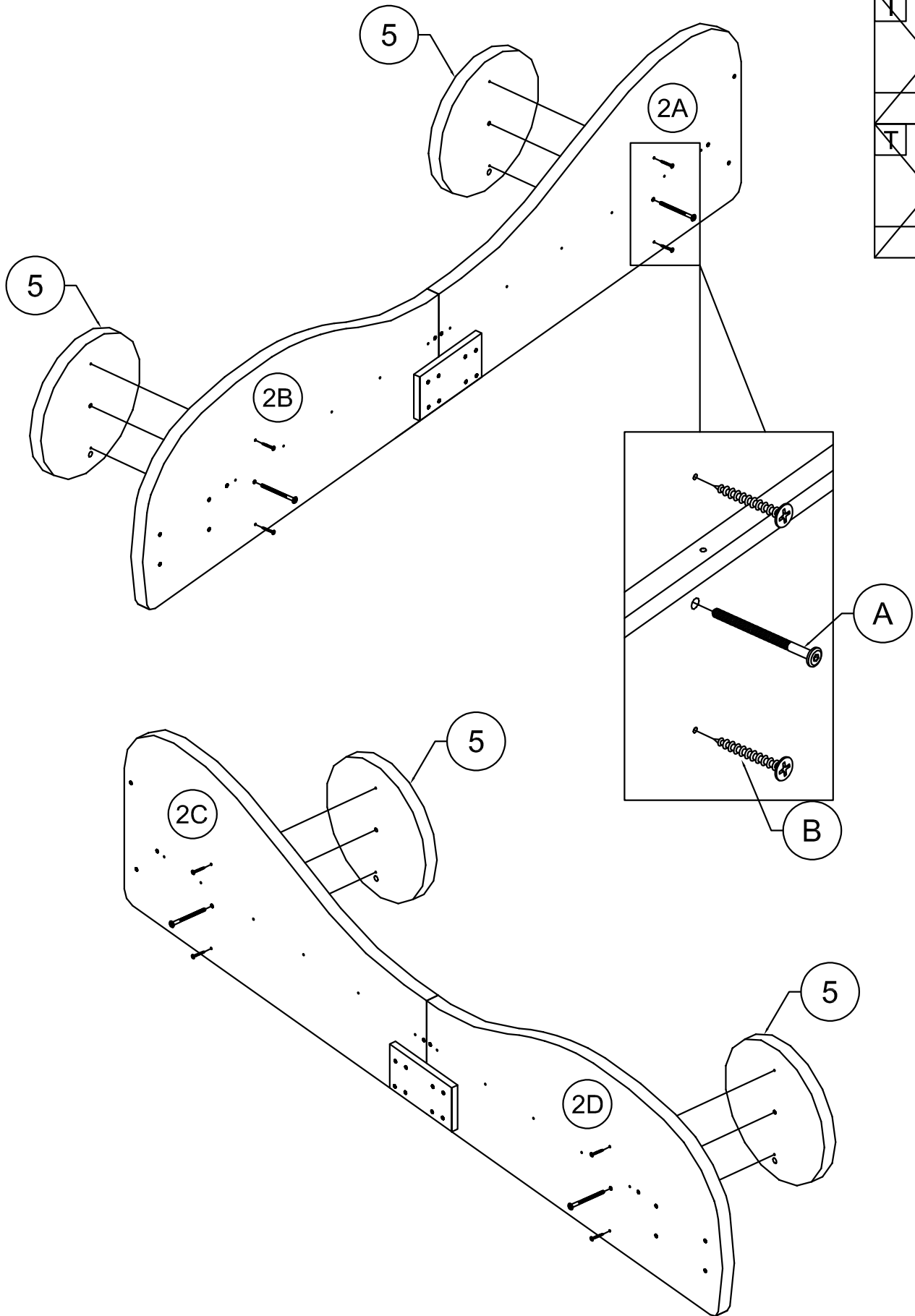

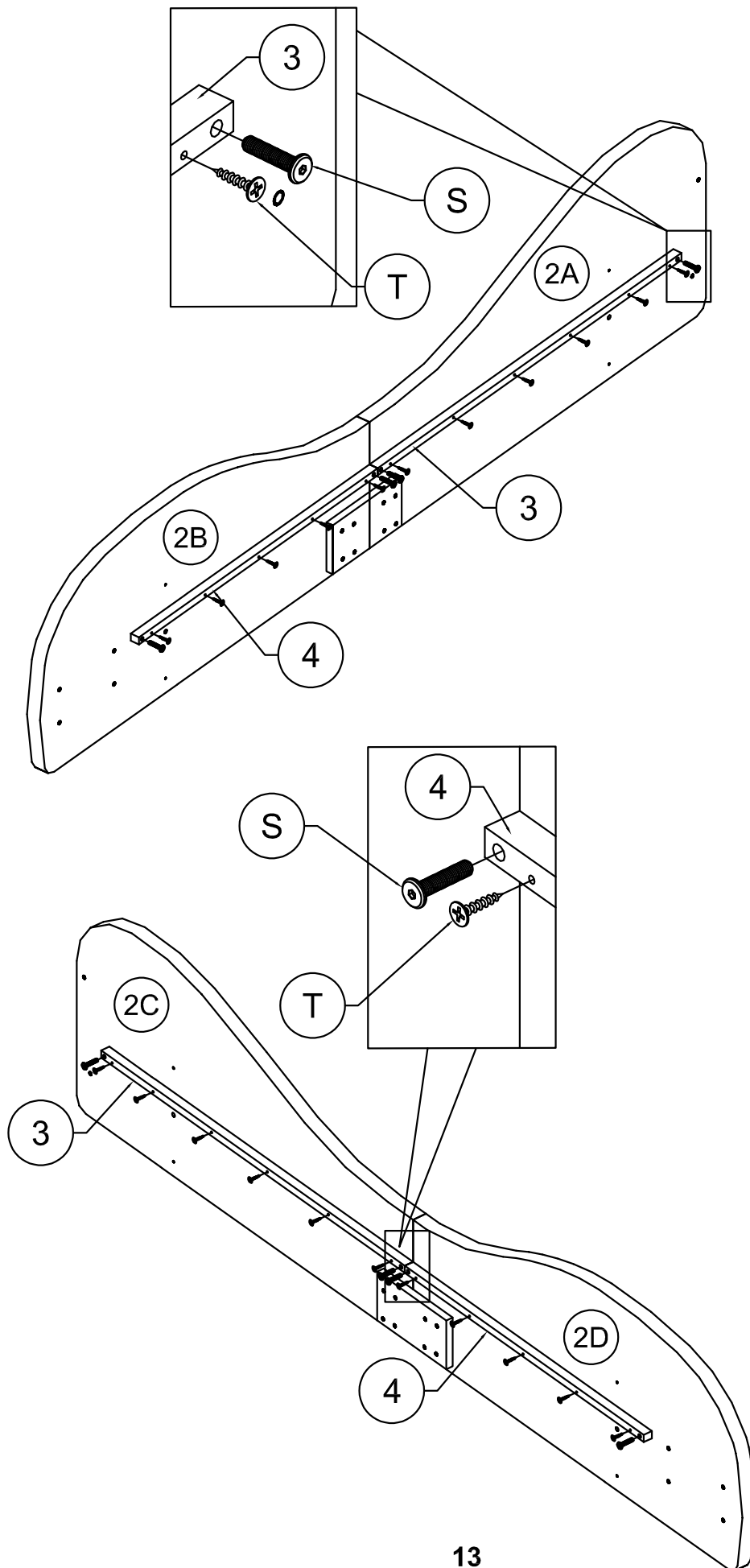

SCHRITT 2: Nachfolgende Abbildung:

A 	B 
4stk	8stk
	





SCHRITT 3: Nachfolgende Abbildung:





T		S	
	22stk		8stk
G		E	
T		L	

SCHRITT 4: Nachfolgende Abbildung:

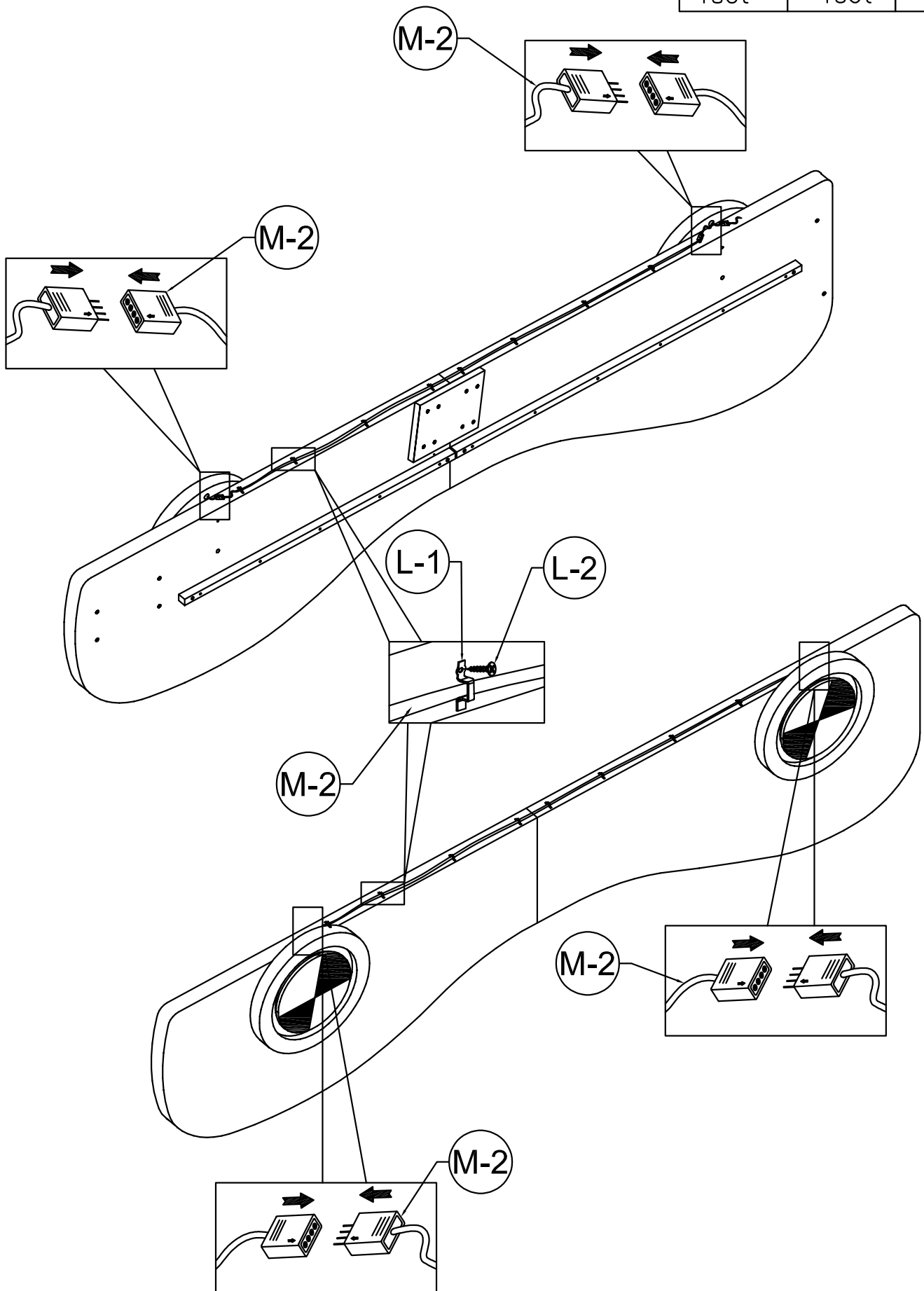
L-1	L-2	M-2
		
1set	1set	2stk



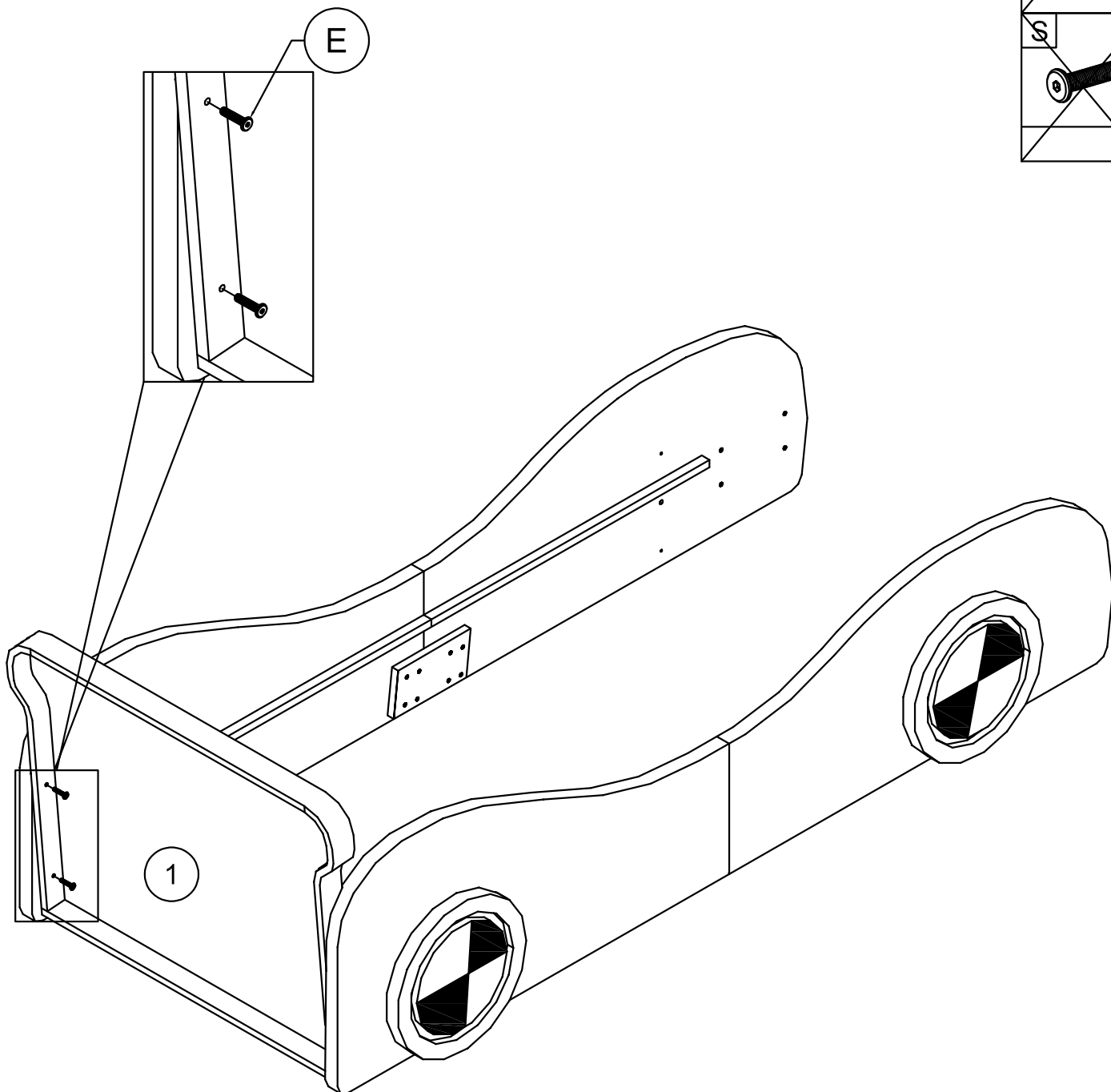

SCHRITT 5: Nachfolgende Abbildung:

E	
4stk	
G	
S	



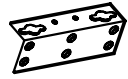

SCHRITT 6.1: Nachfolgende Abbildung:

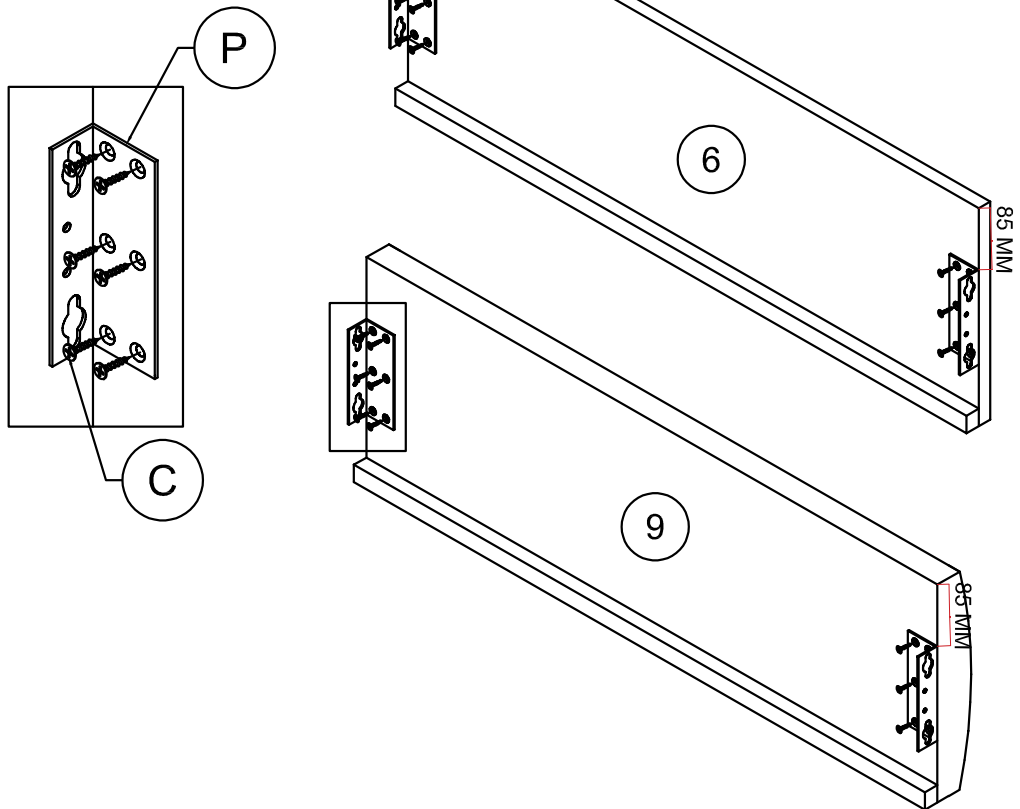
P	C
	
4stk	24stk



SCHRITT 6.2: Nachfolgende Abbildung:

G	
8stk	
E	
S	

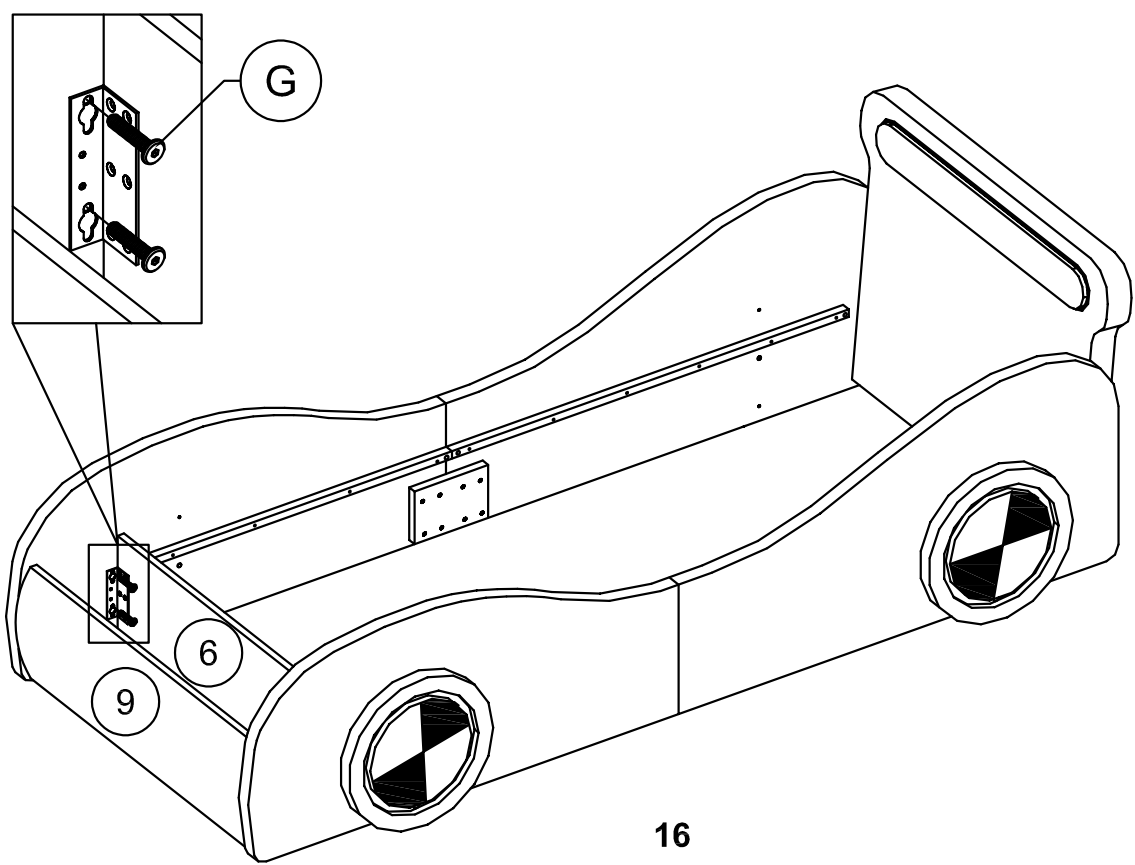

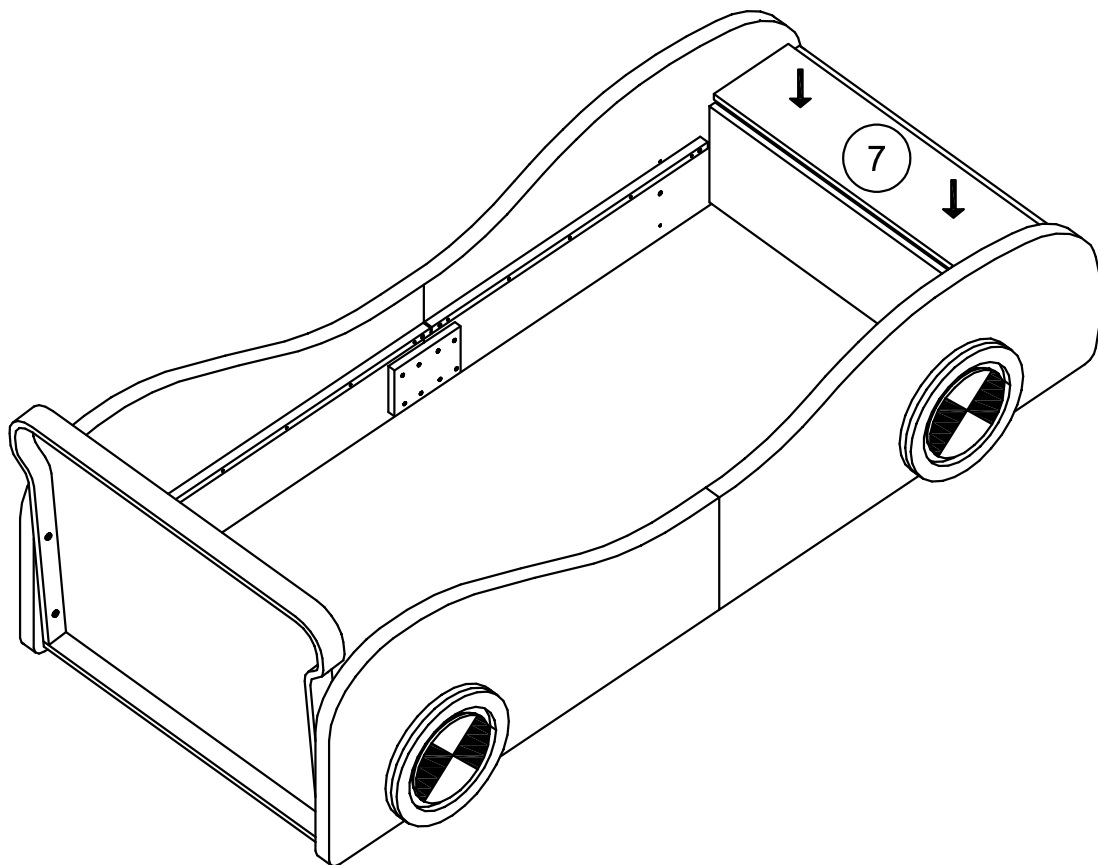

SCHRITT 7.1: Nachfolgende Abbildung:

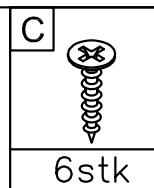
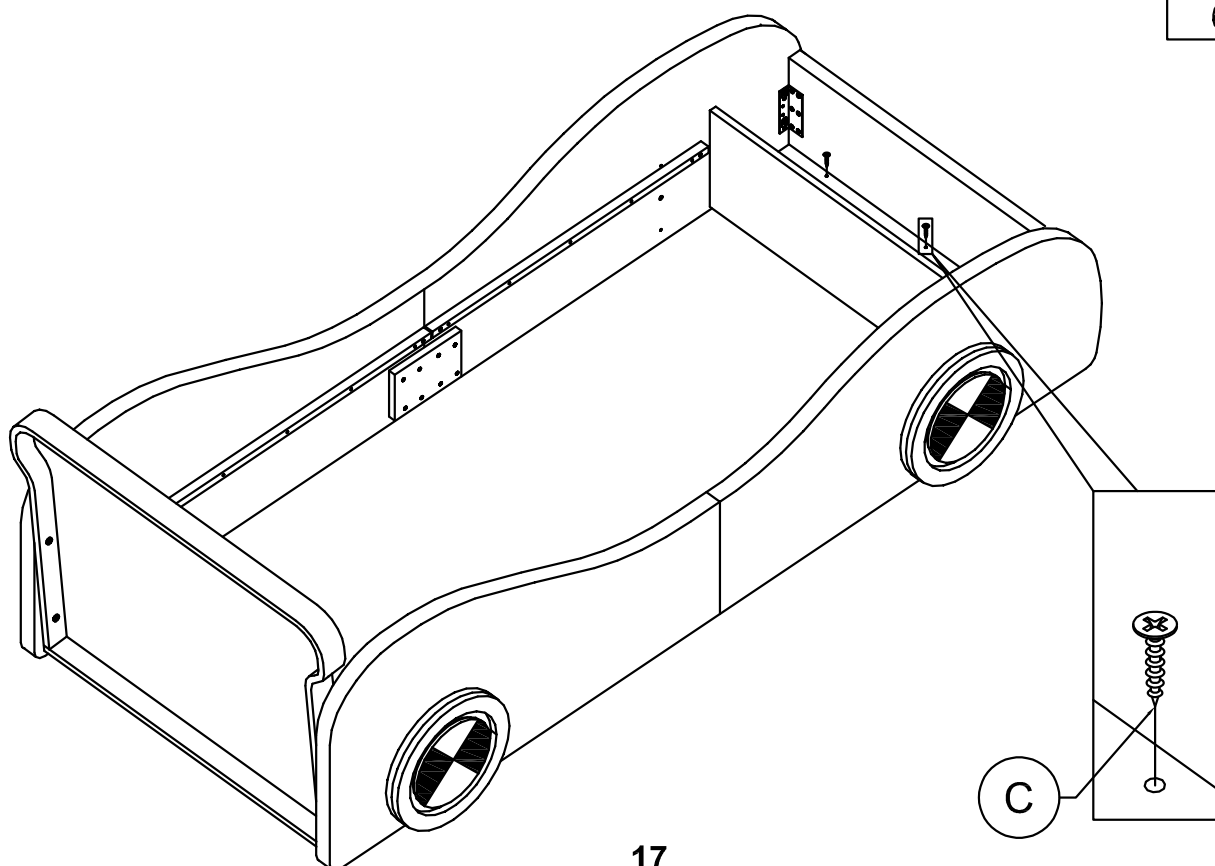

SCHRITT 7.2: Nachfolgende Abbildung:



SCHRITT 8: Nachfolgende Abbildung:

H	C
	
2stk	10stk

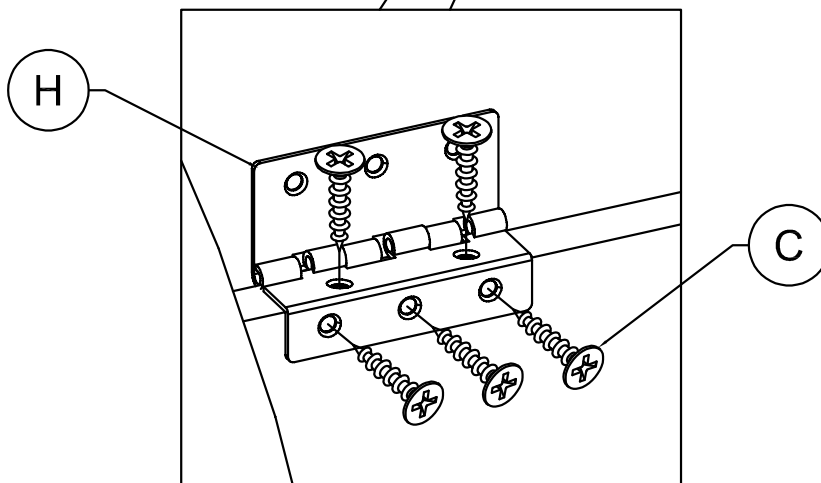
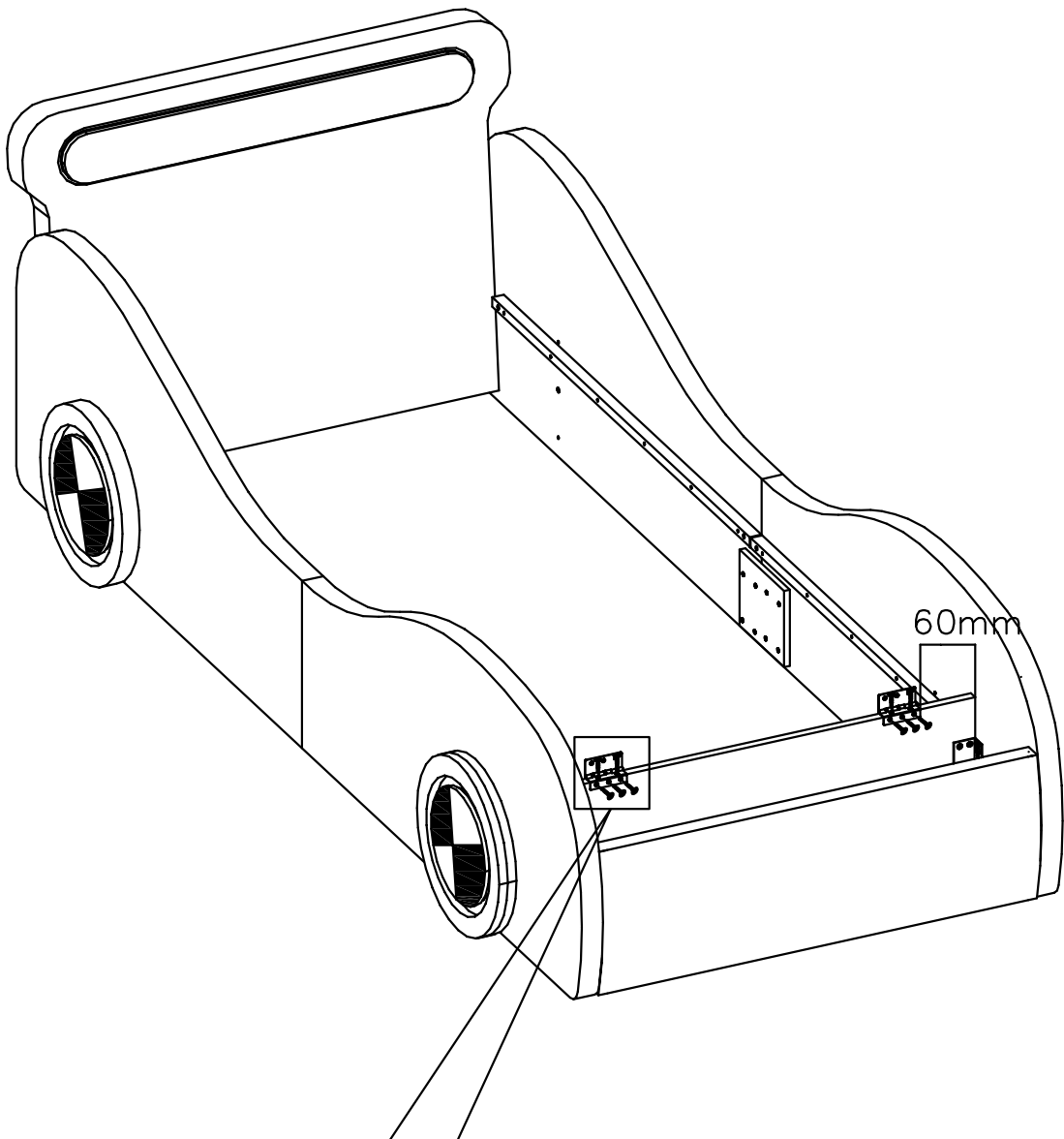

SCHRITT 9: Nachfolgende Abbildung:

C

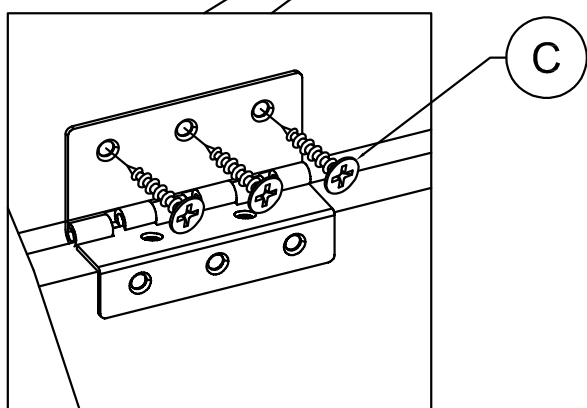
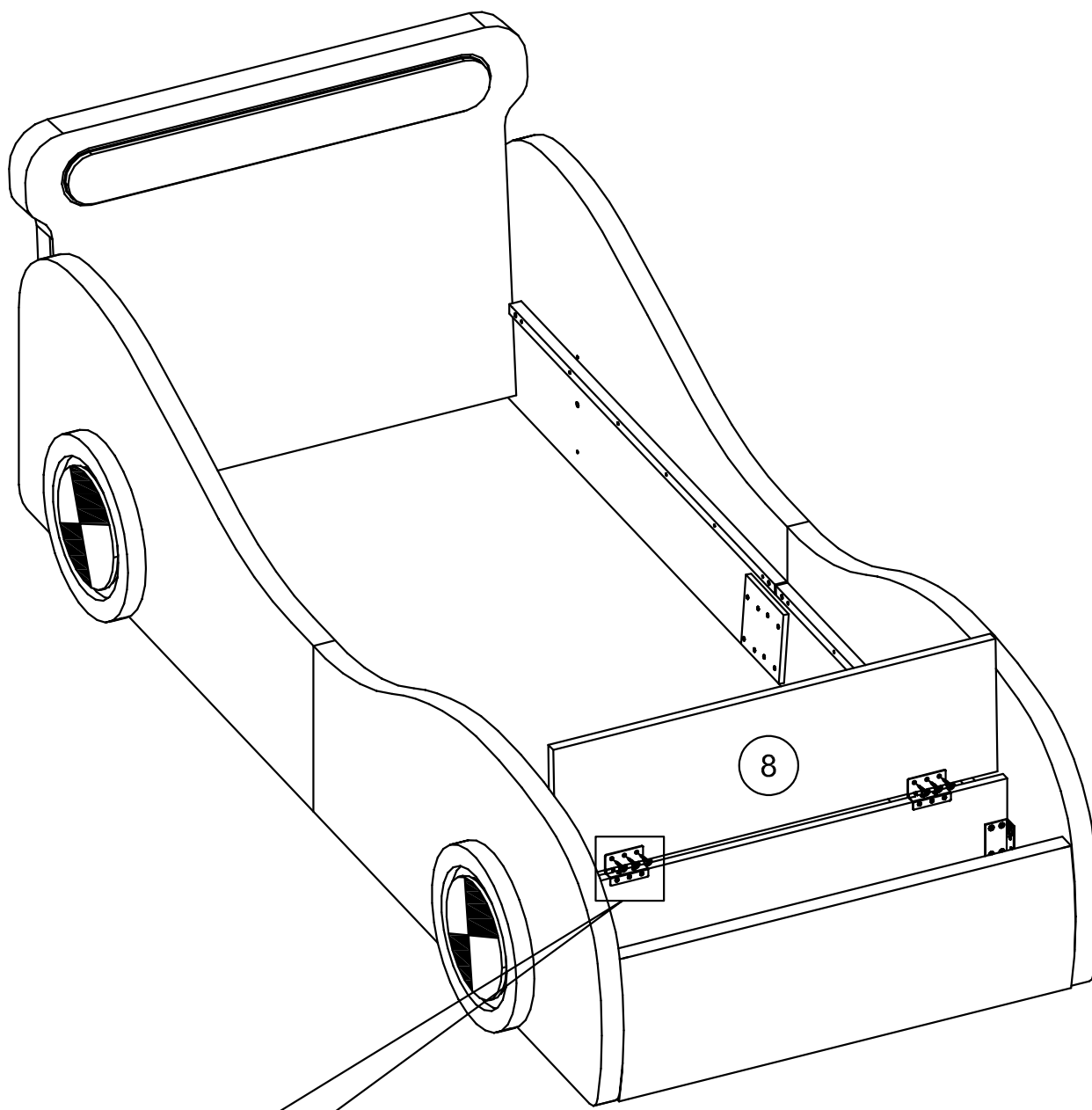
6stk



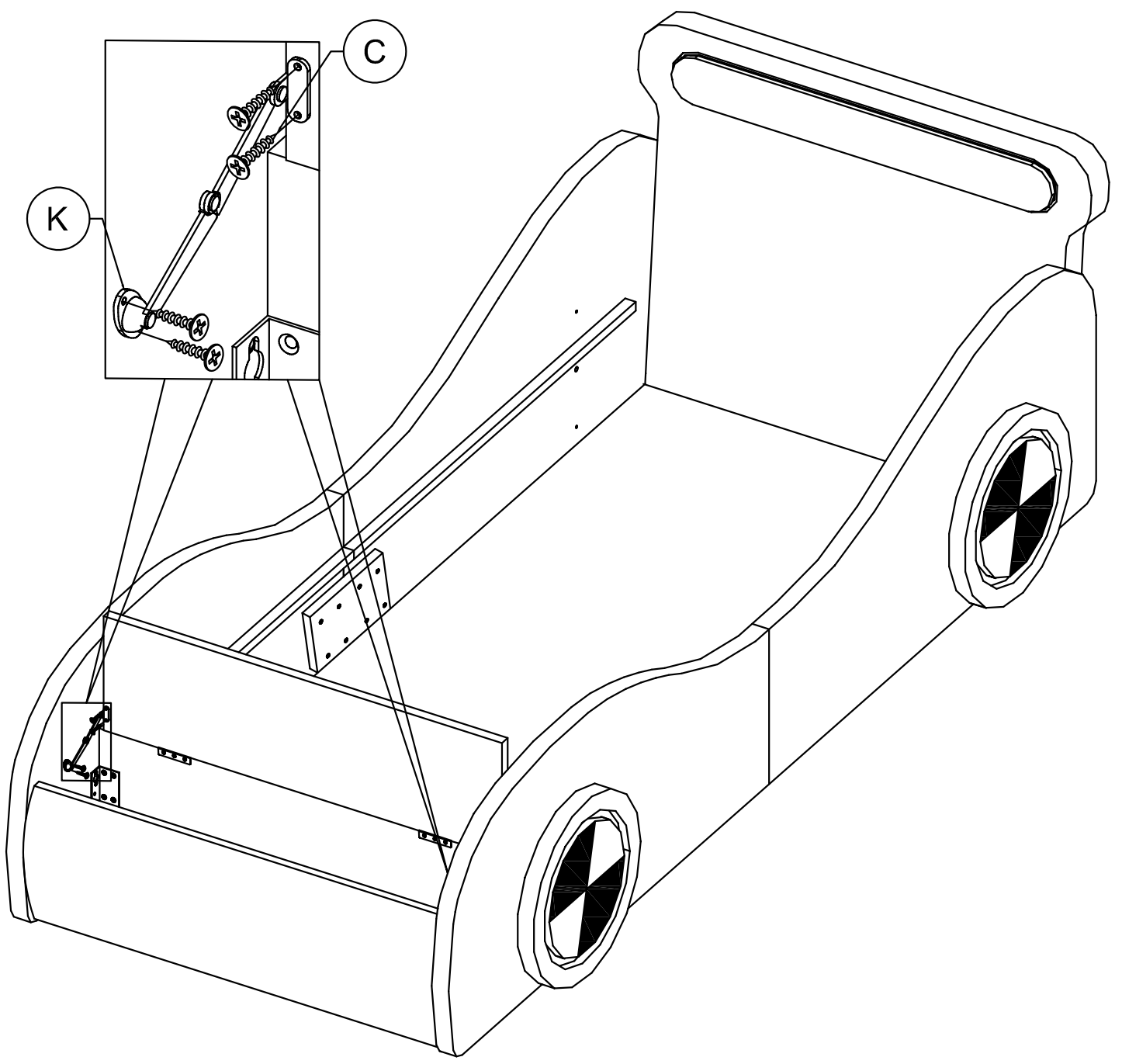

SCHRITT 10: Nachfolgende Abbildung:

K	C
1set	8stk



SCHRITT 11: Nachfolgende Abbildung:

M-1	M-3
	
1stk	1stk

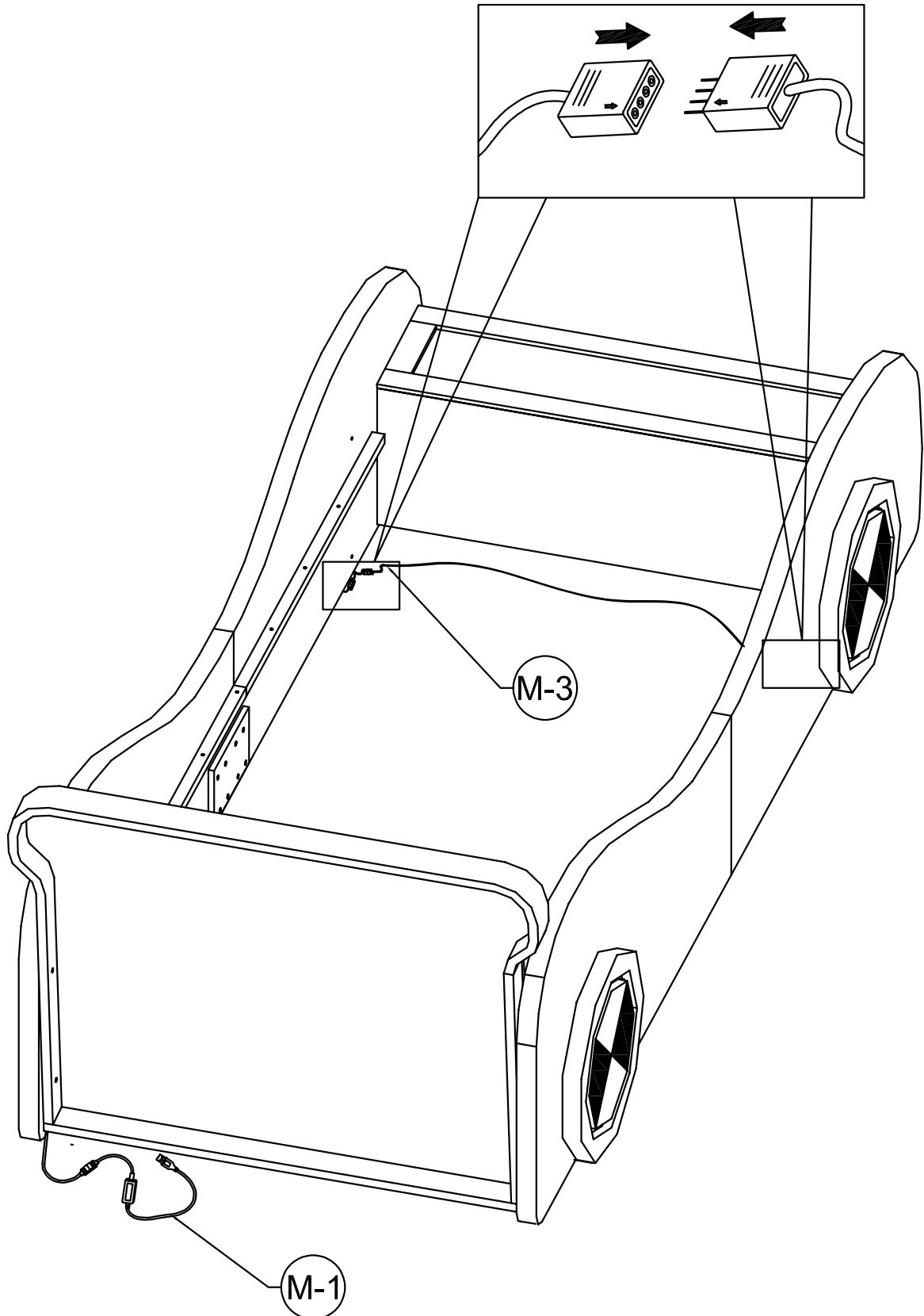

SCHRITT 12: Nachfolgende Abbildung:

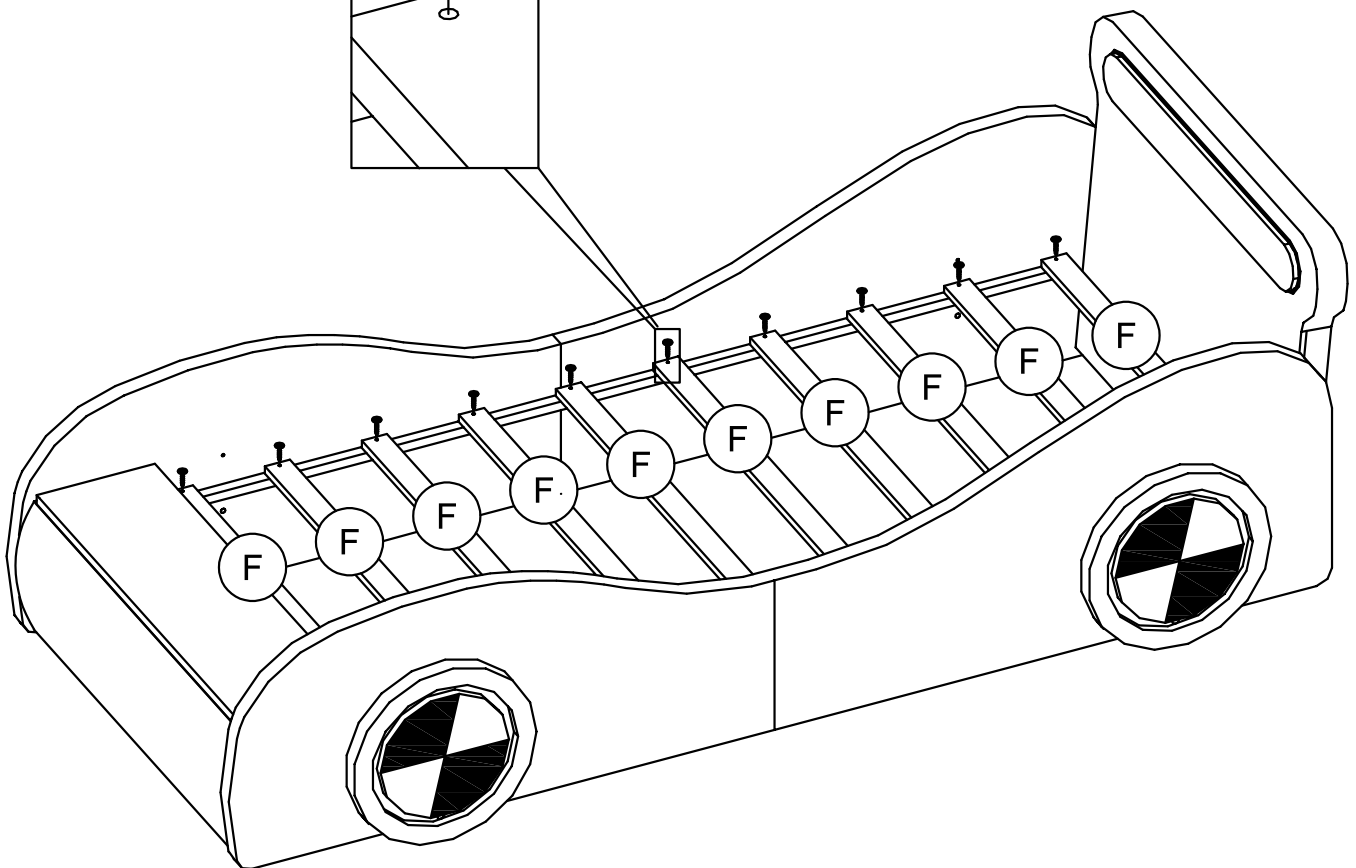
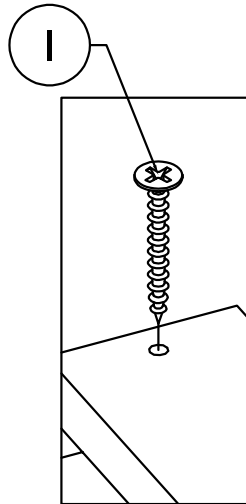
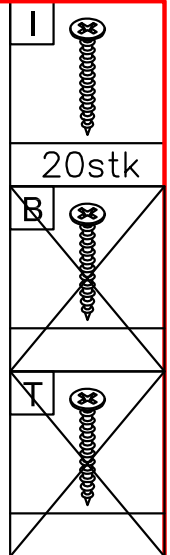

BEENDEN

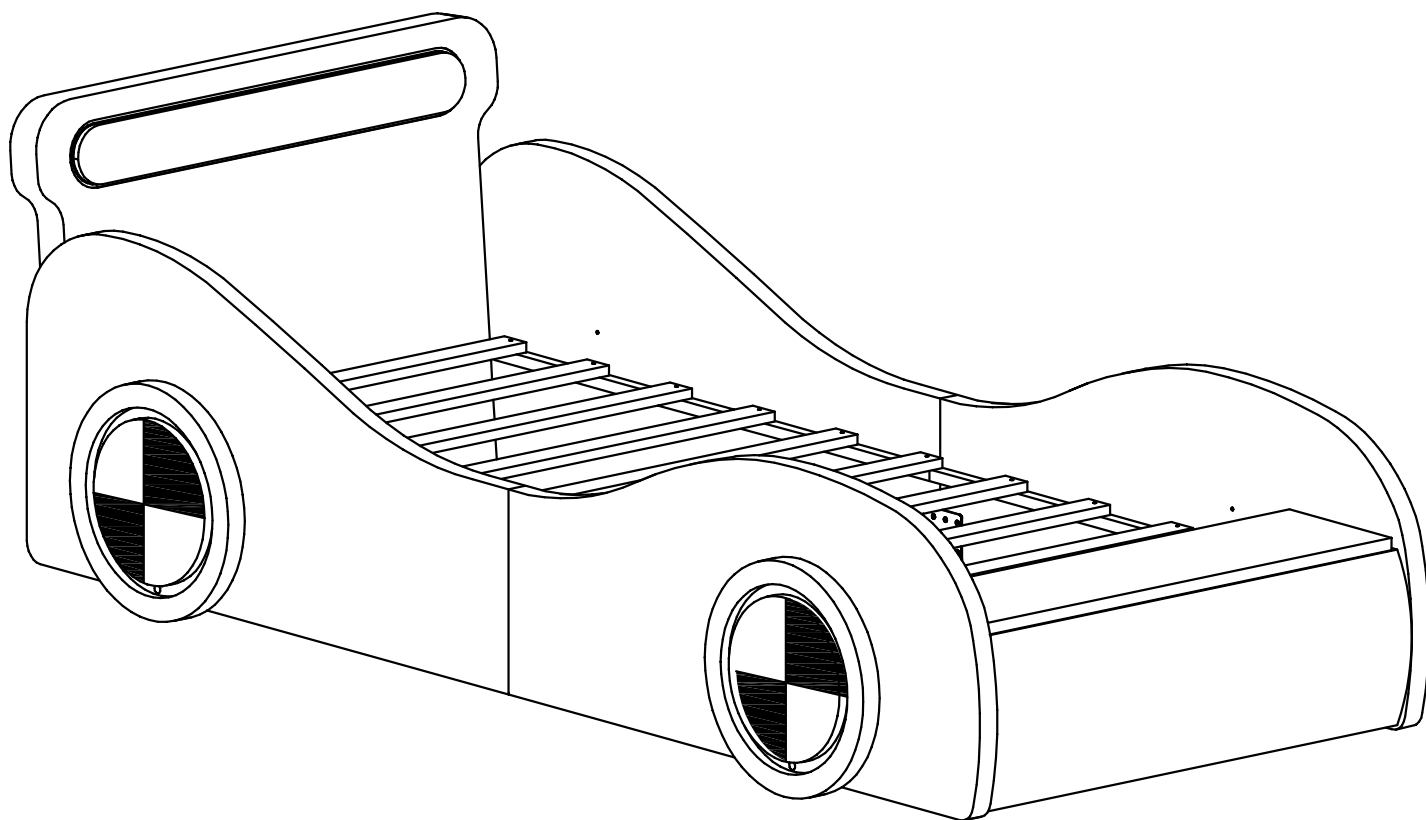



EMC TEST REPORT

Application No. : HXT240611121032

Applicant : Shenzhen South tiger photoelectric technology Co., LTD

Equipment Under Test (EUT)

EUT Name : LED strip

Model No. : 5050RGB

Serial No. : N/A

Trademark : N/A

Receipt Date : 2024-06-06

Test Date : 2024-06-06 to 2024-06-12

Issue Date : 2024-06-12

Standards : EN IEC 55015:2019/A11:2020;
EN IEC 61547:2023.

Conclusions : **PASS**

In the configuration tested, the EUT complied with the standards specified above. The EUT technically complies with the 2014/30/EU directive requirements.

Test/Witness Engineer :



Approved & Authorized :

Andy Zhang

This report details the results of the testing carried out on one sample. The results contained in this test report do not relate to other samples of the same product. The manufacturer should ensure that all products in series production are in conformity with the product sample detailed in the report.