

# GOFFY

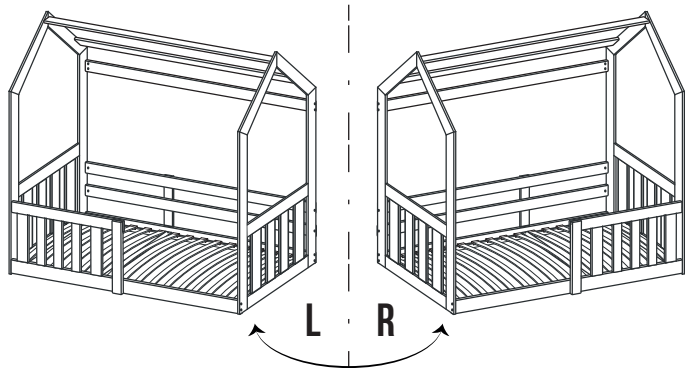

E0101 ACT 180923

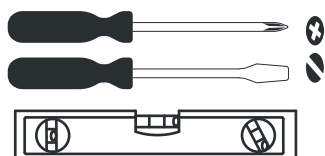
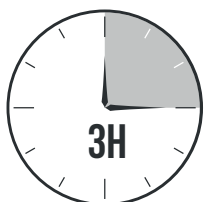
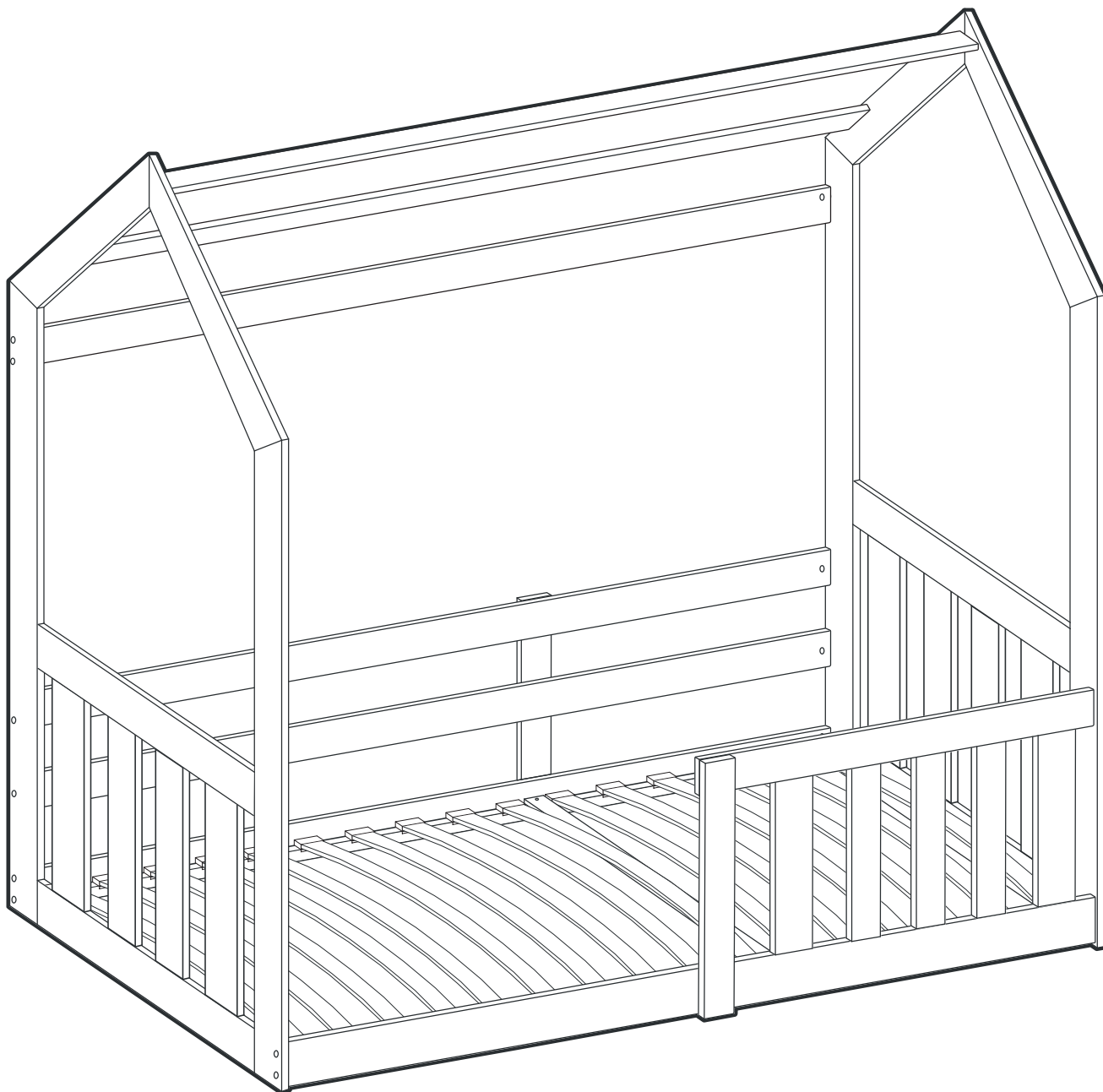

Producent:  
EUROTEL Sp. z o.o.  
Wyprodukowano w Polsce

Manufactured by:

EUROTEL Sp. z o.o.  
MADE IN POLAND

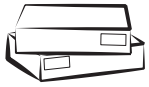

: 1/X

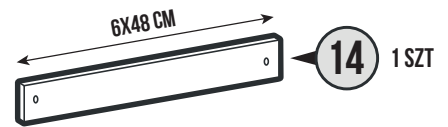
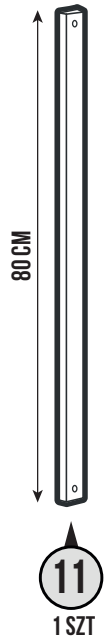
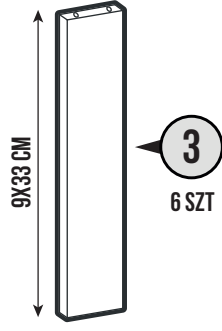
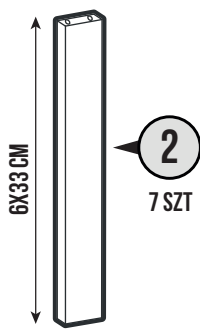

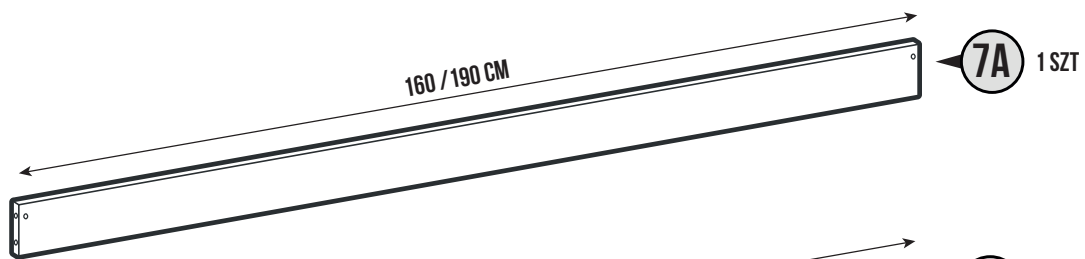

**7A** 1 SZT

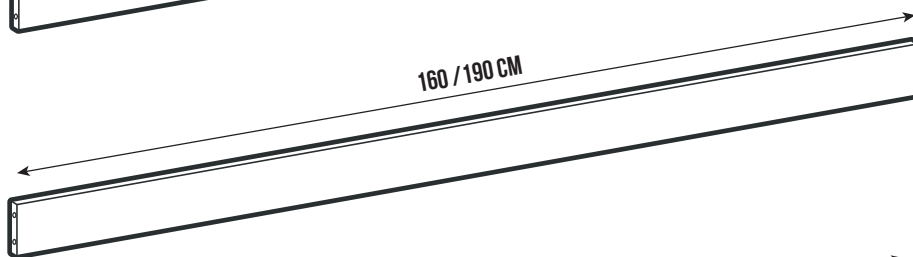

**7B** 1 SZT

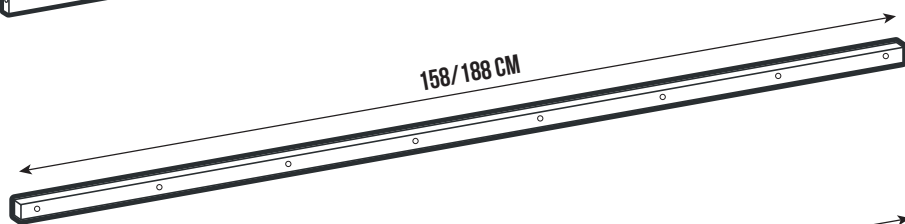

**8** 2 SZT

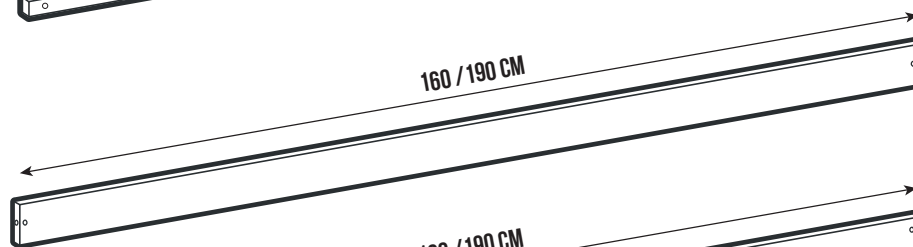

**9** 2 SZT

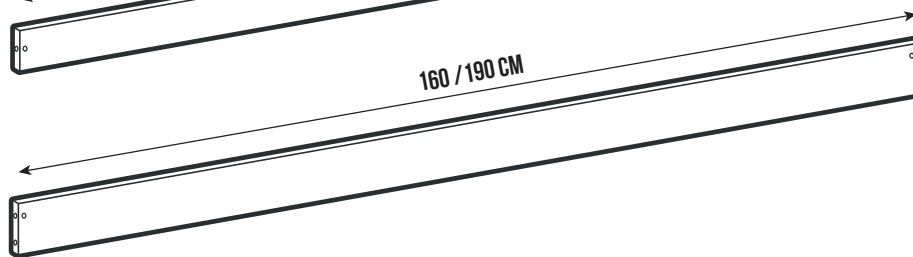

**10** 3 SZT

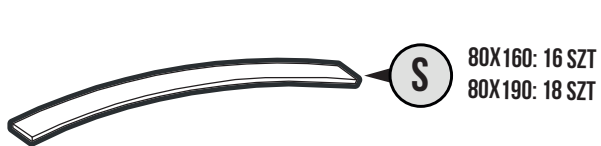

**S** 80X160: 16 SZT  
80X190: 18 SZT

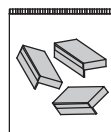

**H** 80X160: 32 SZT  
80X190: 36 SZT

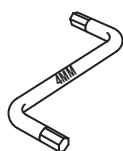

**B-1** SZT



**C-86** SZT



**G-21** SZT



**I-5** SZT



**J-13** SZT

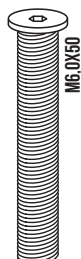

**K-12** SZT



**N-2** SZT



**O-2** SZT



**R-12** SZT

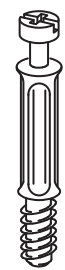

**U-8** SZT



**Y-8** SZT

80X160: **W-32** SZT

80X190: **W-36** SZT



# 1

# 2X

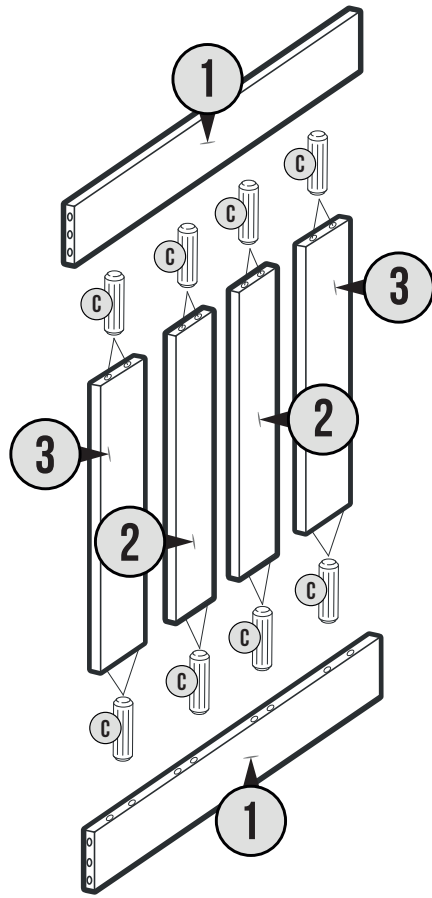

I-1 SZT



C-32 SZT

# 2

# 2X

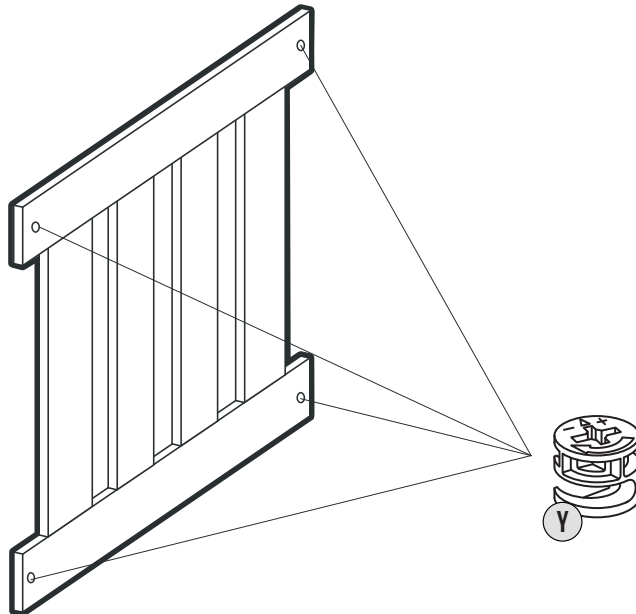

Y-8 SZT

## 3

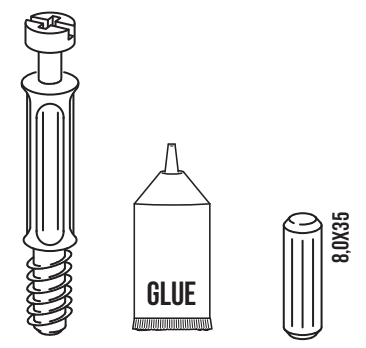
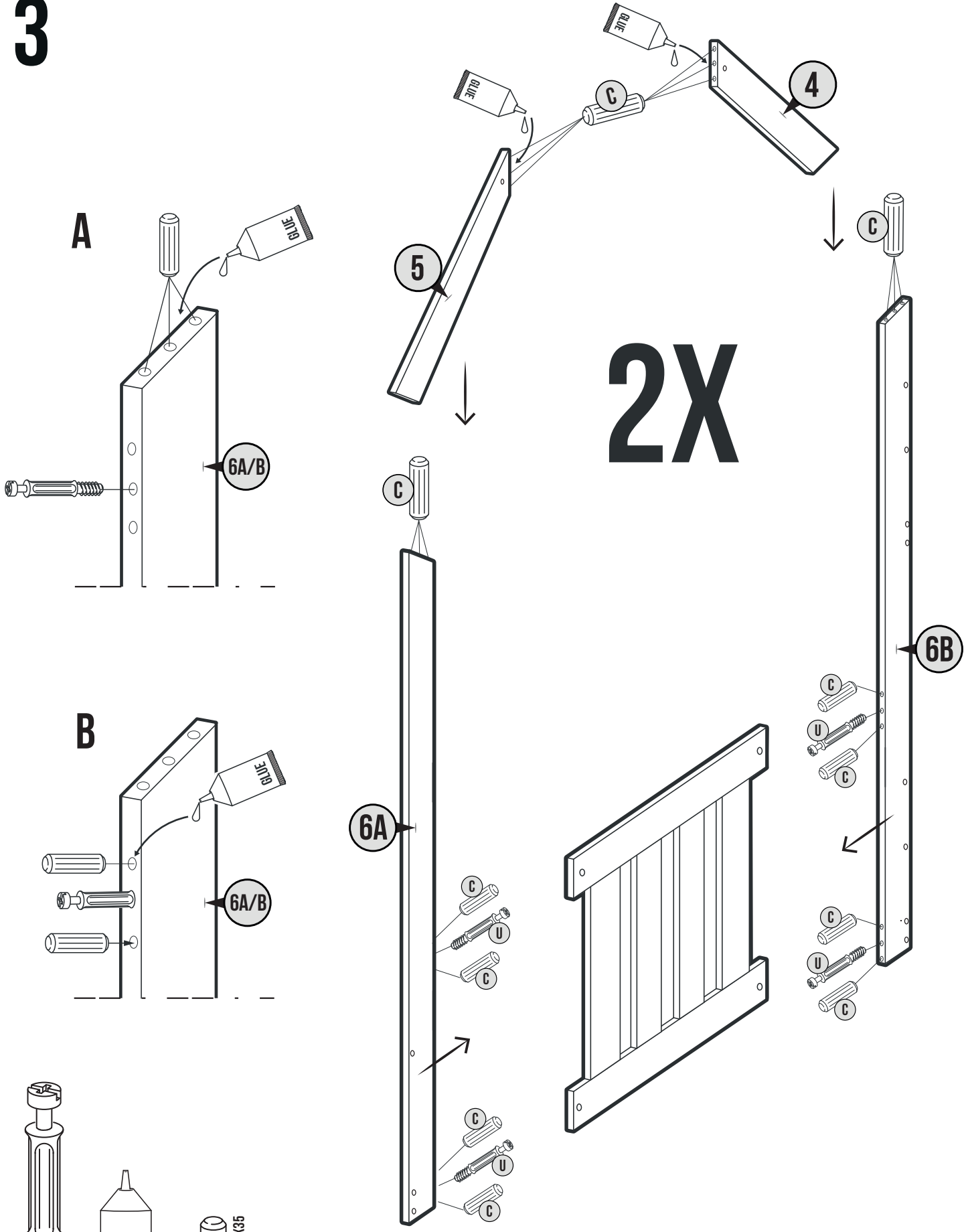

U-8 SZT I-1 SZT C-34 SZT

## 5

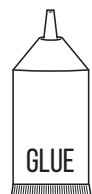

GLUE  
1-2 SZT

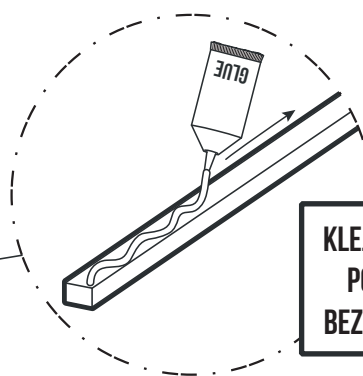
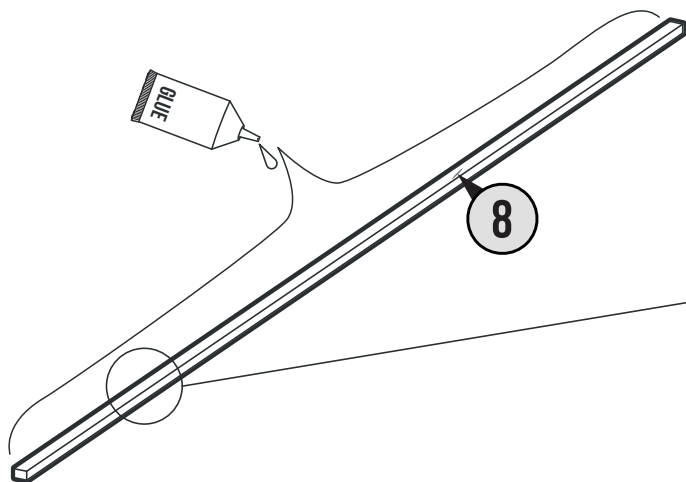

**KLEJ APLIKOWAĆ  
PO STRONIE  
BEZ NAWIERTÓW**

## 6

**! PAMIĘTAJ O DOKŁADYM  
WKRĘCENIU  
ELEMENTU G**

# 2X

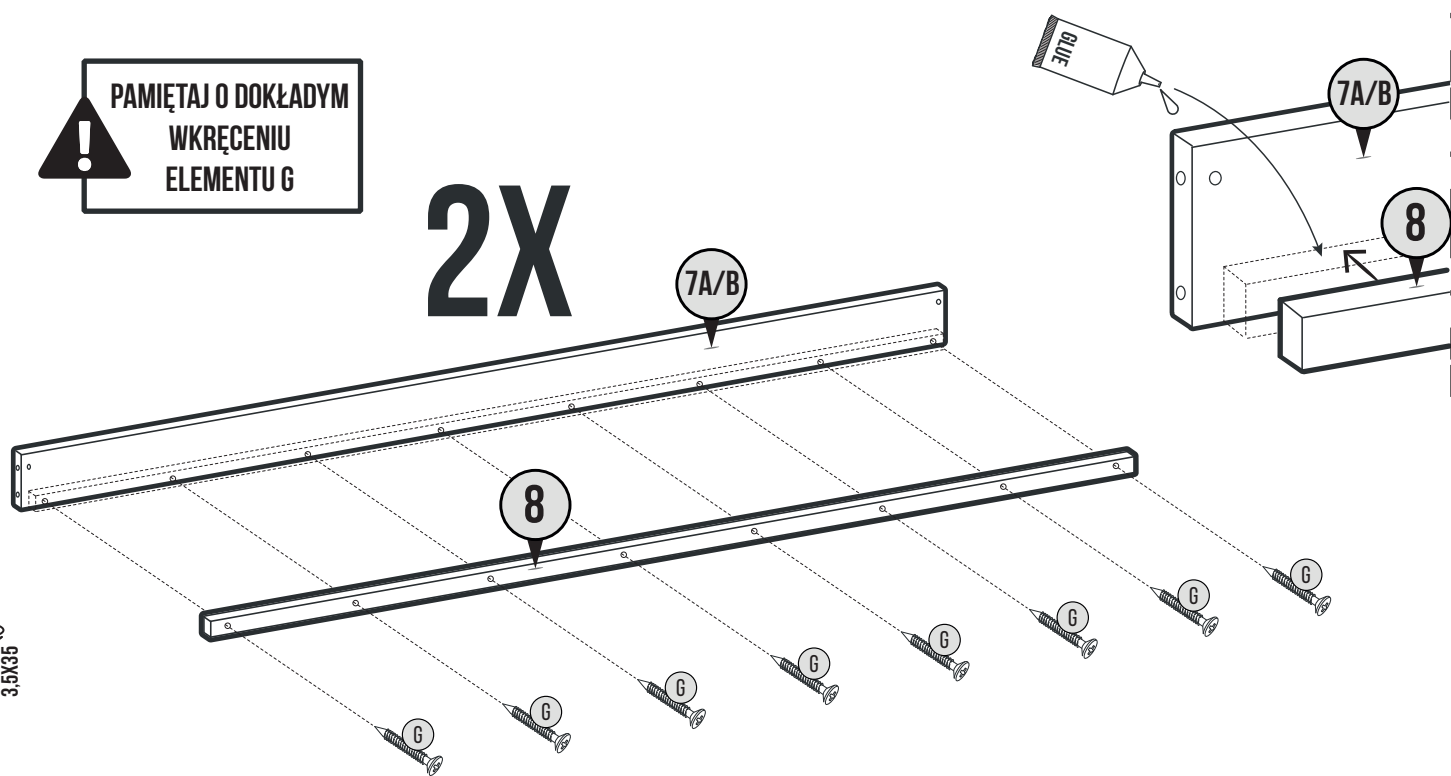

G-16 SZT

## 7

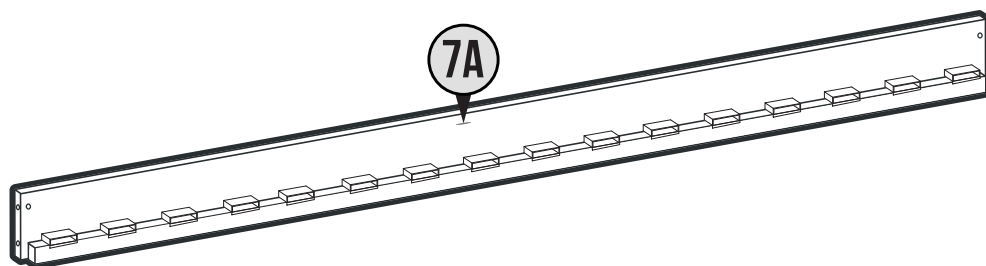
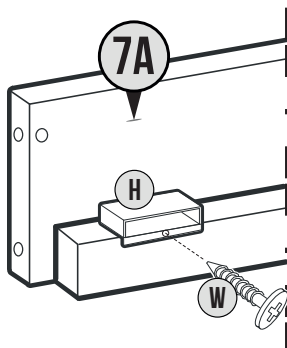

# 16/18X

80X160: H-16 SZT W-16 SZT  
80X190: H-18 SZT W-18 SZT

## 8

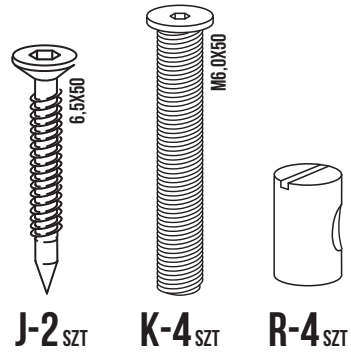
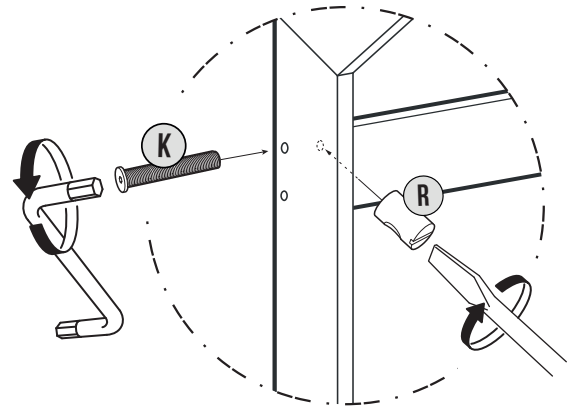
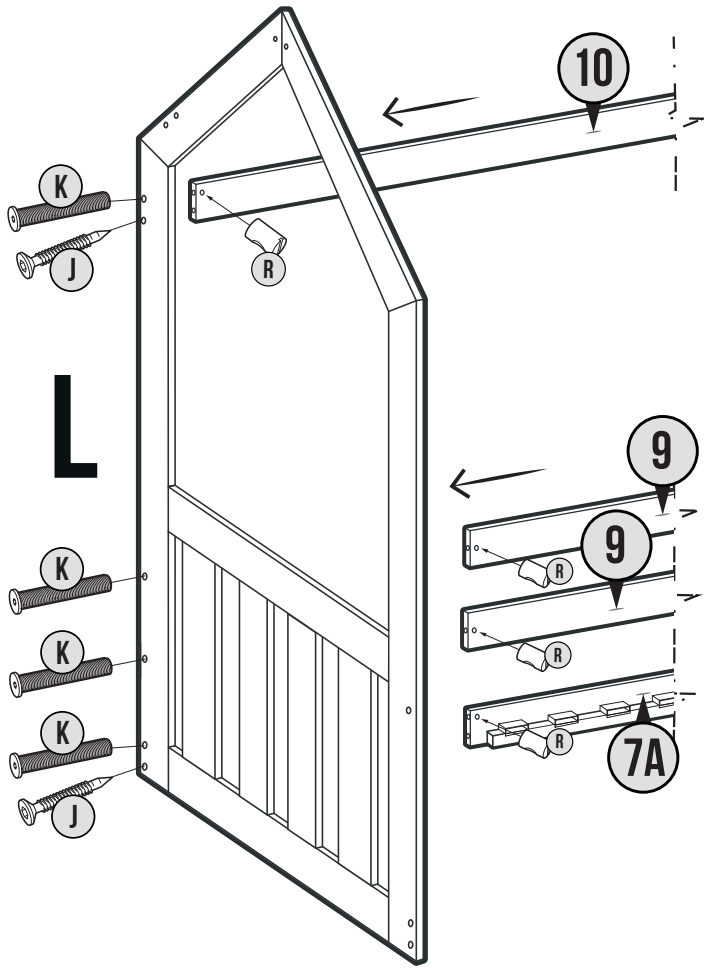

## 9

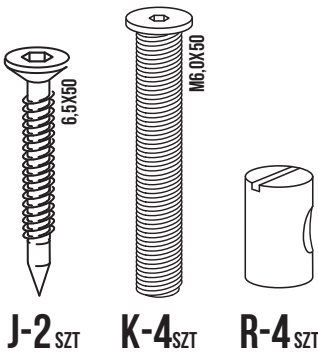
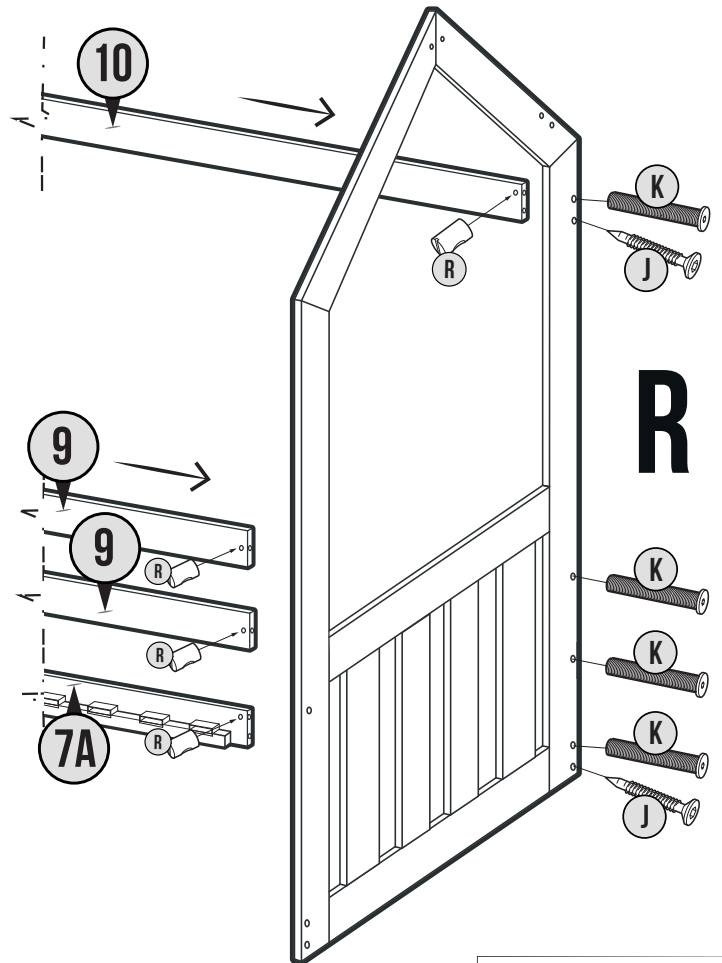
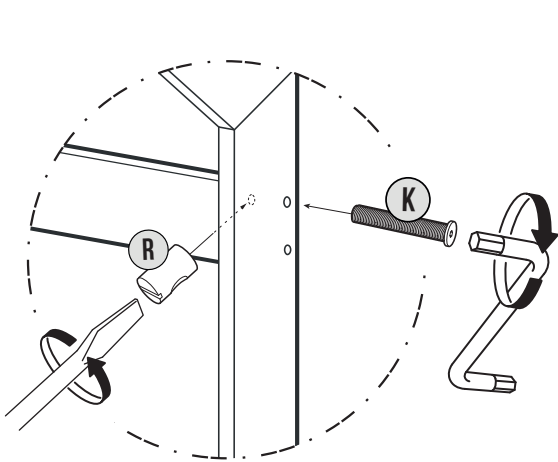

## 10

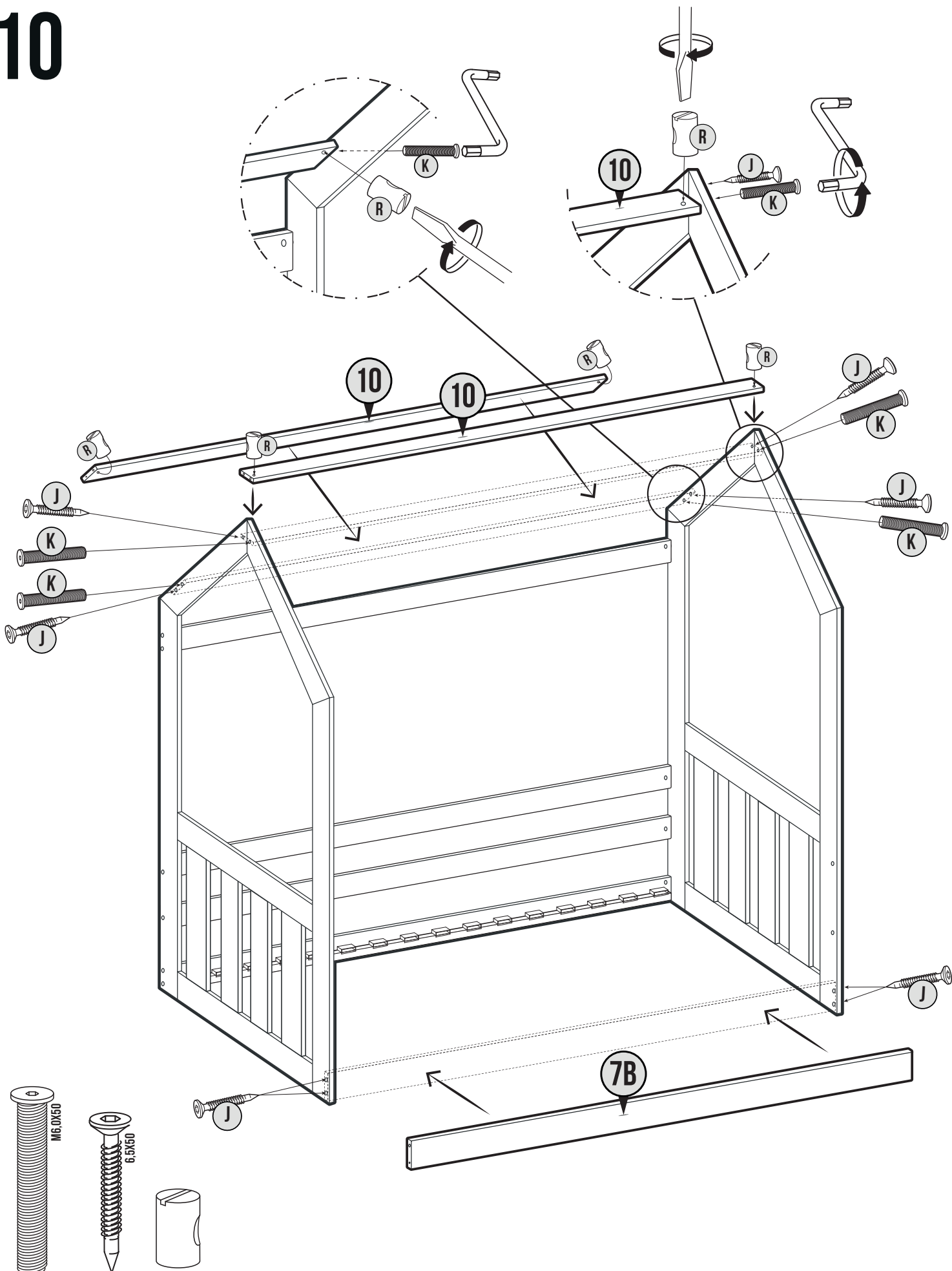

K-4 szt

J-8 szt

R-4 szt



## 11

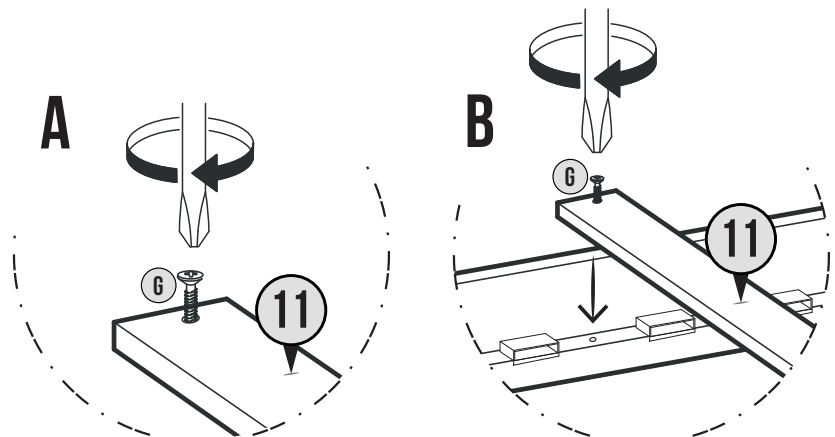
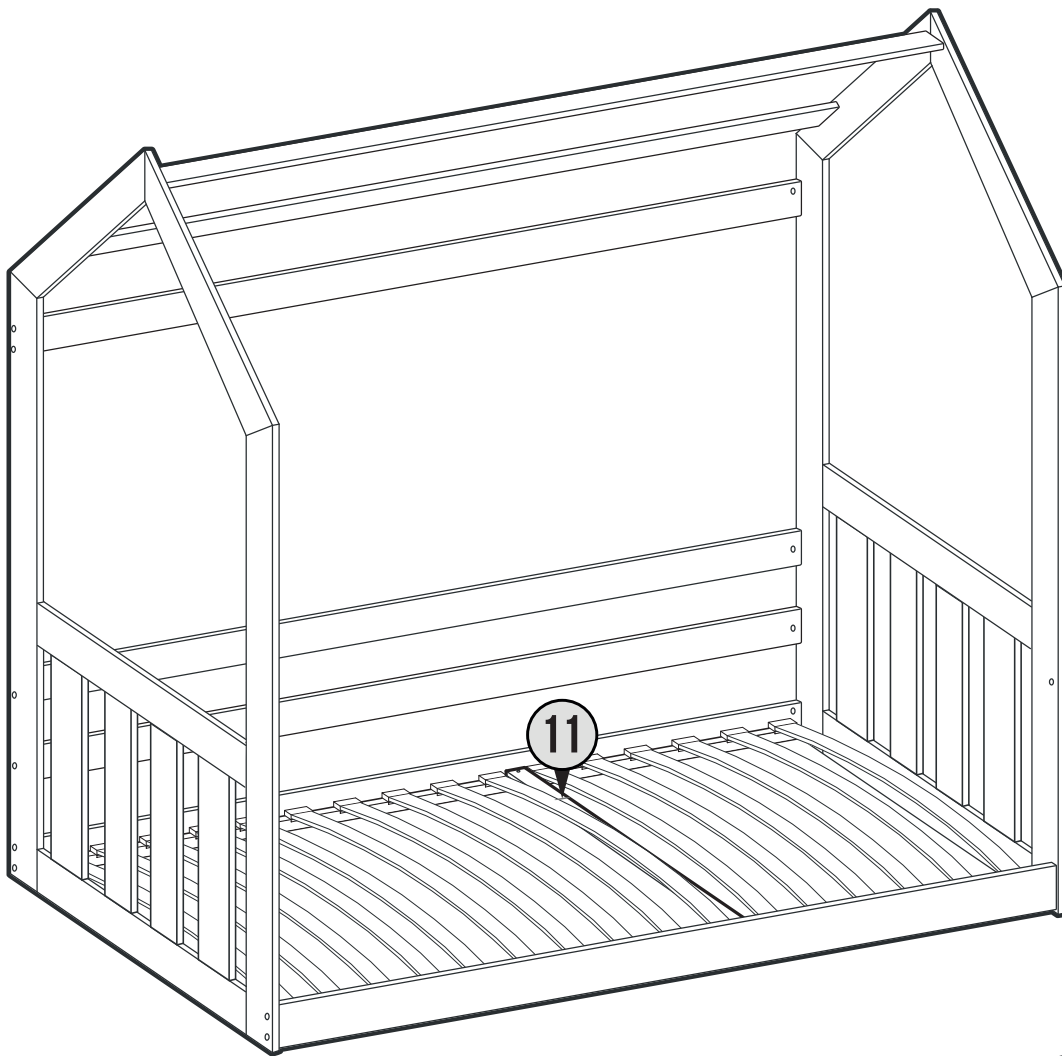
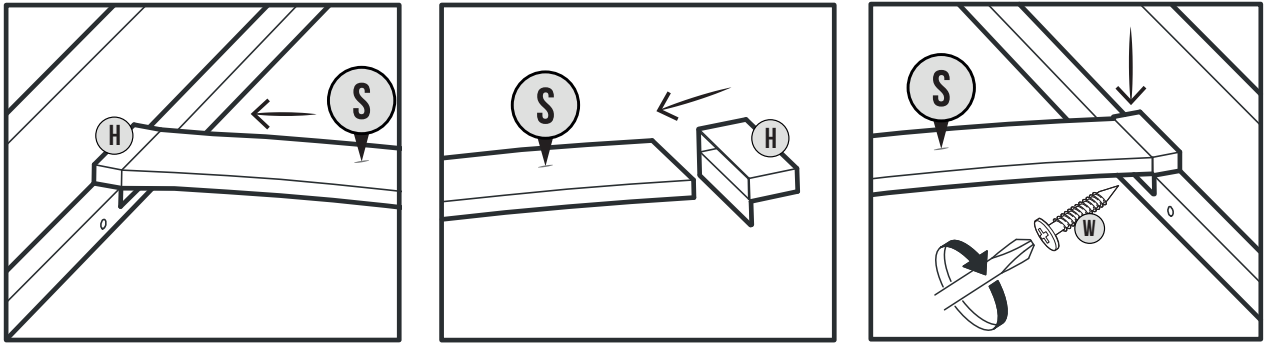

80X160: H-16<sub>SZT</sub>

W-16<sub>SZT</sub>

80X190: H-18<sub>SZT</sub>

W-18<sub>SZT</sub>

G-2<sub>SZT</sub>

## 12

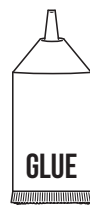
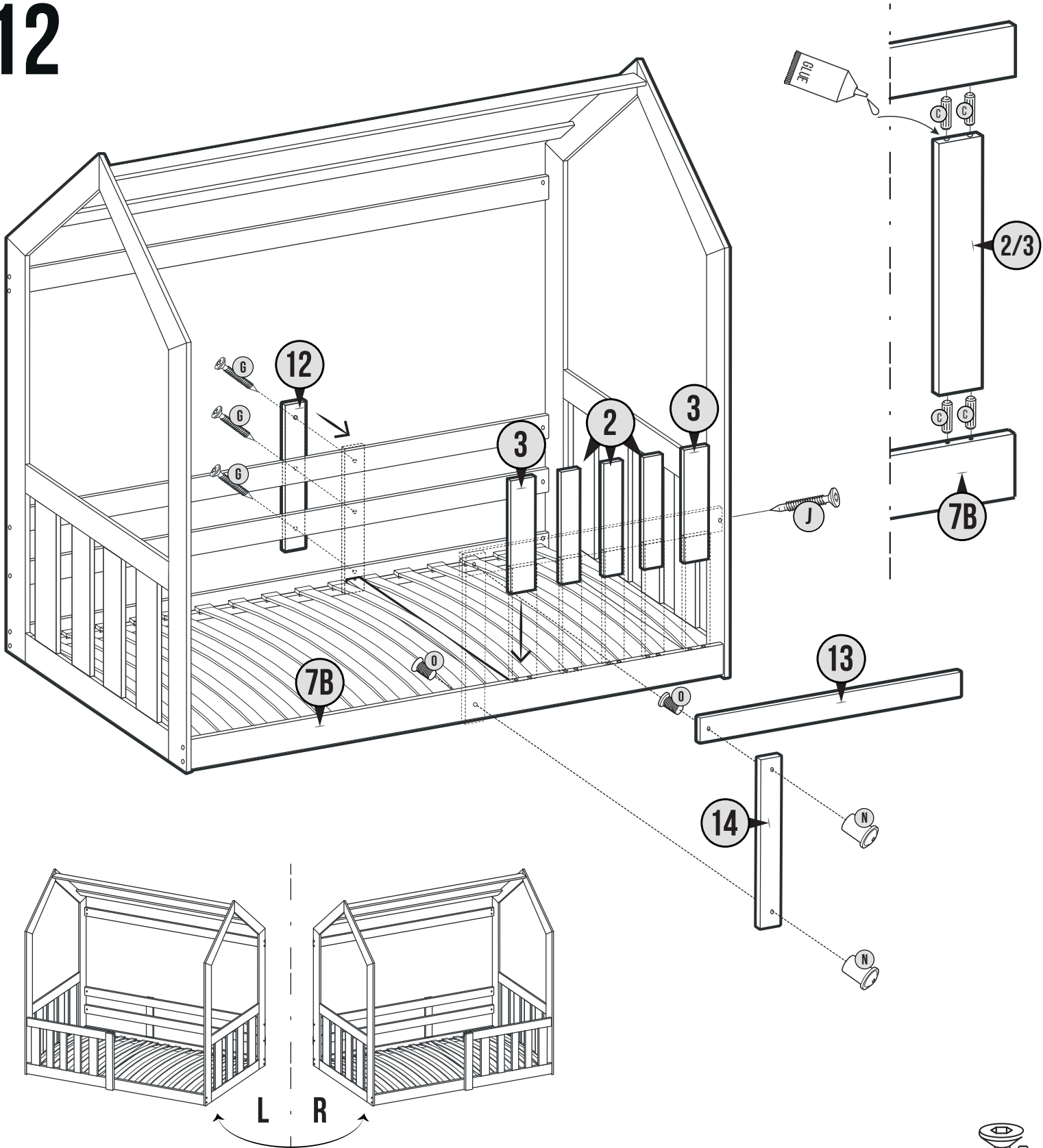

I-1 SZT



O-20 SZT

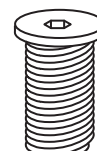

N-2 SZT



C-3 SZT



J-1 SZT



G-3 SZT



