

MONTAGEANLEITUNG

Artikelnummer: WF530685/WF530686

Dieses Set ist in 2 Boxen enthalten. Wenn Sie keine vollen 2 Boxen erhalten wenden Sie sich bitte an unseren Kundenservice.

This set comes in 2 boxes. If you do not receive a full 2 boxes, please contact our customer service.

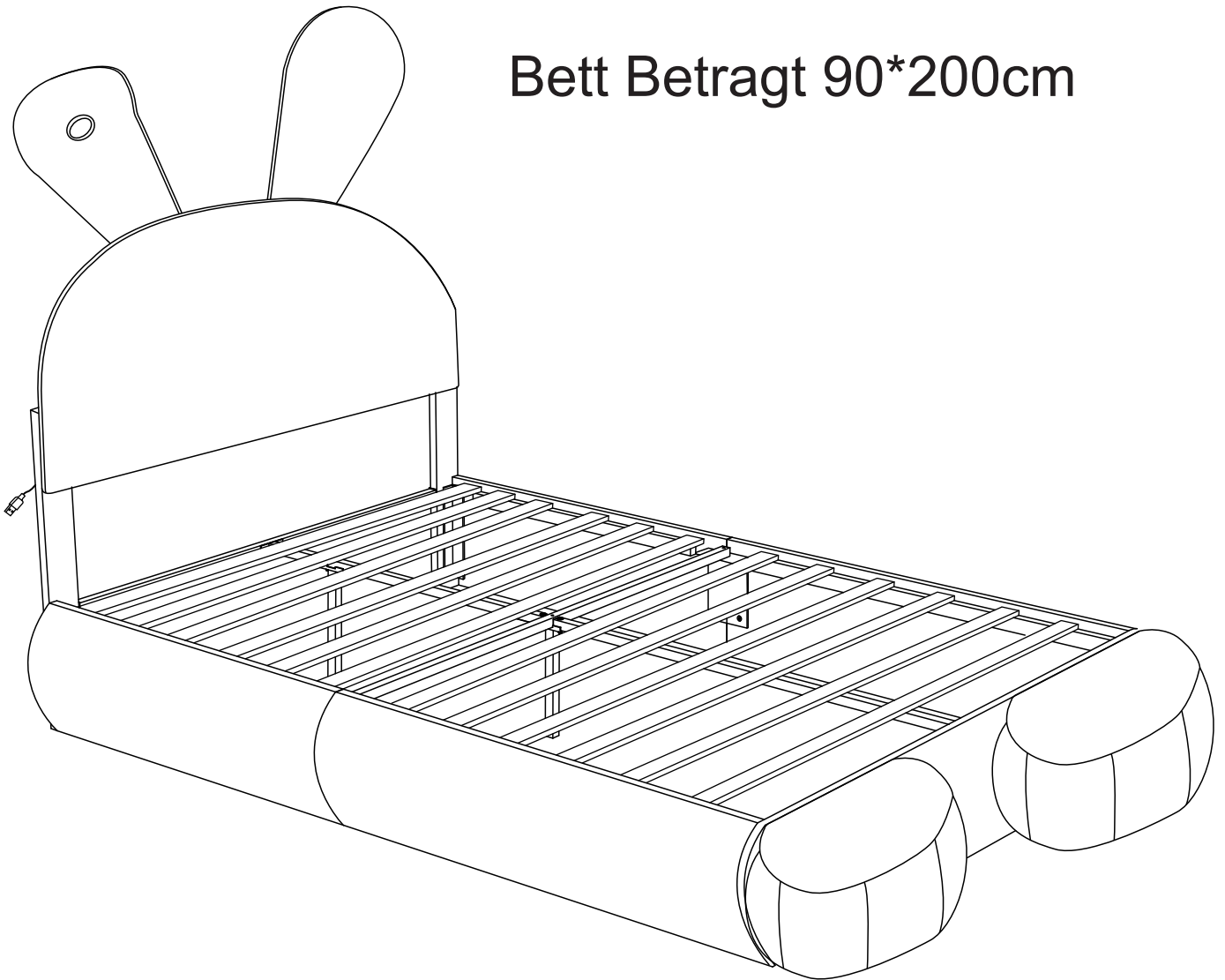

Bett Betragt 90*200cm

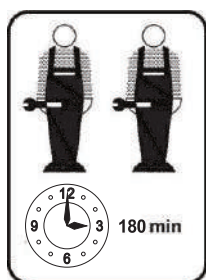

Stückliste

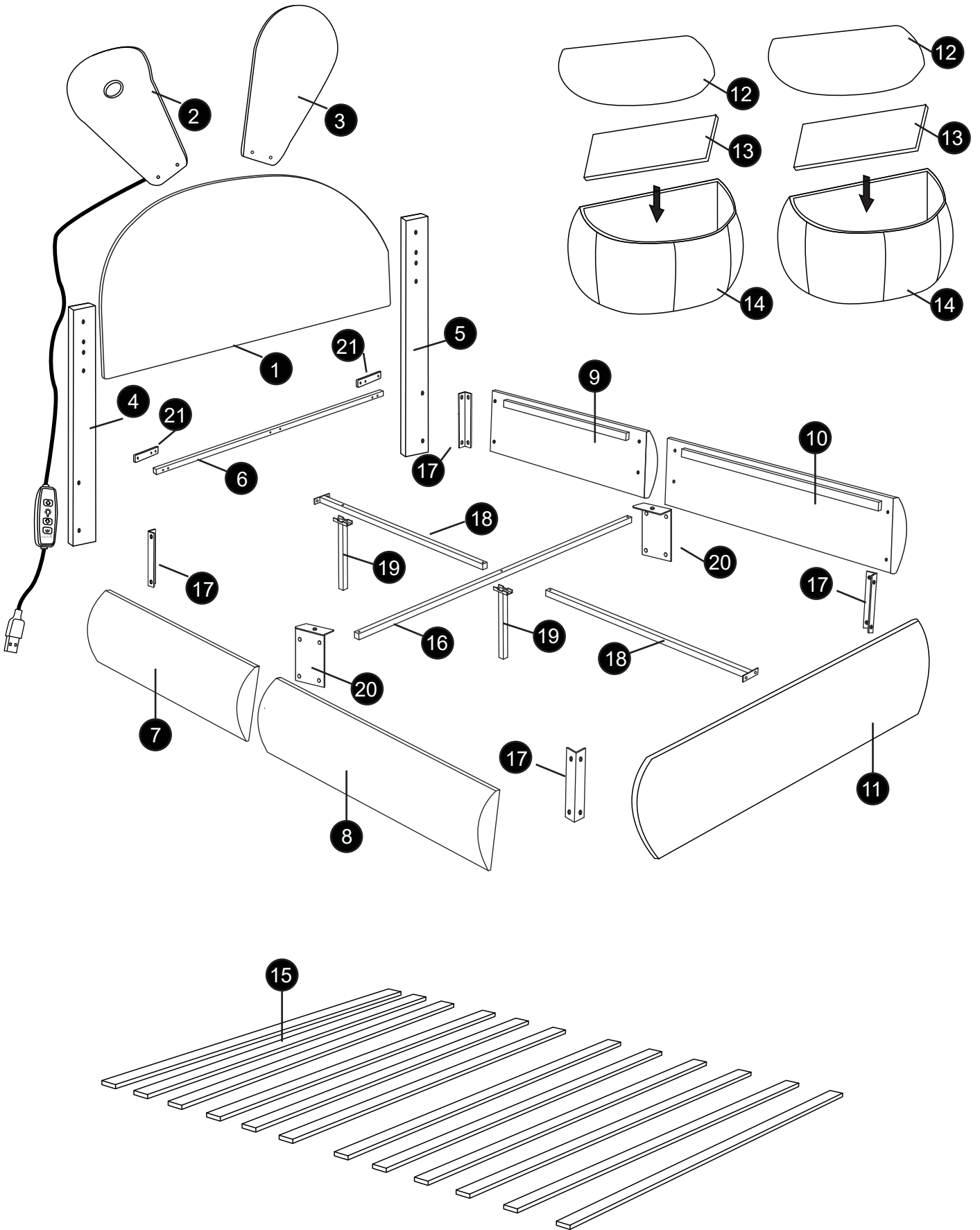

INSTRUCTIONS

IMPORTANT-READ CAREFULLY-RETAIN FOR FUTURE REFERENCE

- a) **WARNING** -Children can become trapped between the bed and the wall, the adjoining pieces of furniture (e.g. cupboards) and the like. To avoid risk of serious injury the distance between the safety barrier and the adjoining structure shall not exceed 75 mm or shall be more than 230 mm.
- b) **WARNING**-Do not use the bed if any structural part is broken or missing; Replacement parts are between requested from the manufacturer or the store.
- c) **WARNING**-Do not climb or wiggle on any non-designated structures.
- d) It is imperative to always follow the installation instructions and manufacturer's use.
- e) The recommended size of the mattress to be used with the bed is **90x200cm**, maximum thickness mattress:**20cm**.
- f) It is necessary to ventilate the room in order to maintain a low level moisture and prevent mold growth in the bed and its periphery.
- g) Joining devices should always be tightened properly and regularly verified. Tighten if necessary.



ANLEITUNGEN

WICHTIG - SORGFÄLTIG LESEN - FÜR SPÄTERE VERWENDUNG AUFBEWAHREN

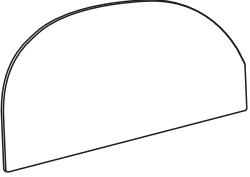
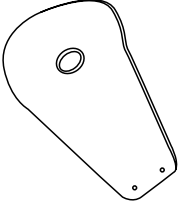
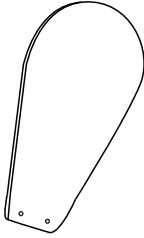

- a) **WARNUNG**-Kinder können zwischen dem Bett und der Wand, den angrenzenden Möbelstücken (z. B. Schränken) und der Lücke eingeklemmt werden. Um die Gefahr schwerer Verletzungen zu vermeiden, darf der Abstand zwischen der Sicherheitsbarriere und der angrenzenden Struktur nicht mehr als 75 mm oder mehr als 230 mm betragen.
- b) **WARNUNG**-Das Bett darf nicht benutzt werden, wenn ein Bauteil gebrochen ist oder fehlt;
Ersatzteile sind beim Hersteller oder im Geschäft anzufordern.
- c) **WARNUNG**-Klettern oder wackeln Sie nicht auf nicht dafür vorgesehenen Strukturen.
- d) Befolgen Sie unbedingt die Installationsanweisungen und die Gebrauchsanweisungen des Herstellers.
- e) Die empfohlene Größe der Matratze für das Bett beträgt **90x200cm**, maximale Dicke der Matratze: **20cm**.
- f) Es ist notwendig, den Raum zu lüften, um die Feuchtigkeit niedrig zu halten und Schimmelbildung im Bett und seiner Umgebung zu verhindern.
- g) Die Verbindungselemente sollten immer richtig angezogen sein und regelmäßig überprüft werden. Ziehen Sie sie gegebenenfalls nach.

PARTS LIST

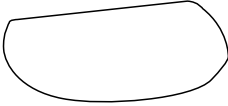
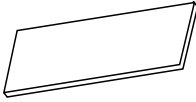
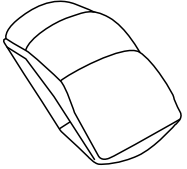
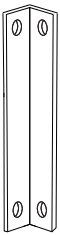
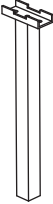
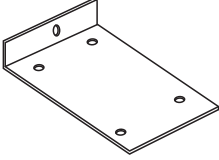
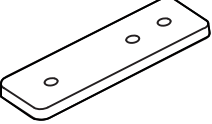
WF530686

1 x1 	2 x1 	3 x1 	4 x1 	
5 x1 	12 x2 	13 x2 	14 x2 	
17 x4 	19 x2 	20 x2 	21 x2 	

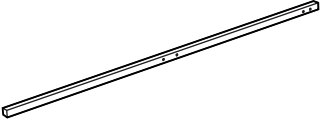
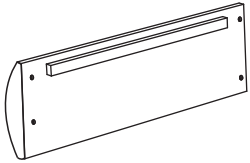
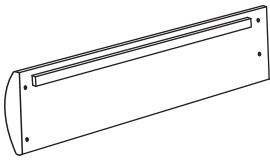
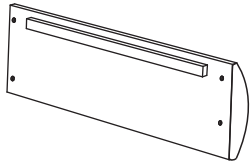
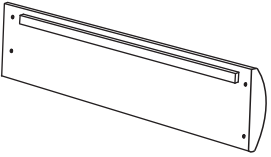
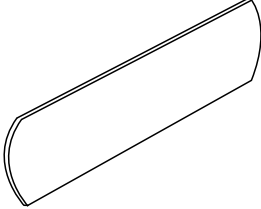
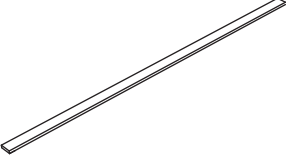
WF530685

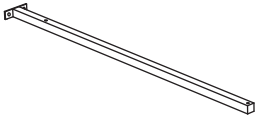
6 x1 	7 x1 	8 x1 	9 x1 
10 x1 	11 x1 	15 x12 	16 x1 
18 x2 			

PARTS LIST

WF530686

A: x14

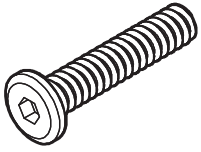

M8*40mm

B: x34

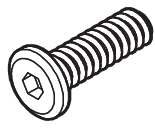

M8*20mm

D: x1

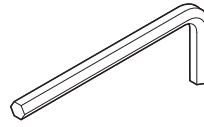

Allen Key M8

ASSEMBLY

Note: Please do not tighten all bolts until the bed is assembled completely.

Hinweis: Bitte ziehen Sie alle Schrauben erst an, wenn das Bett vollständig montiert ist.

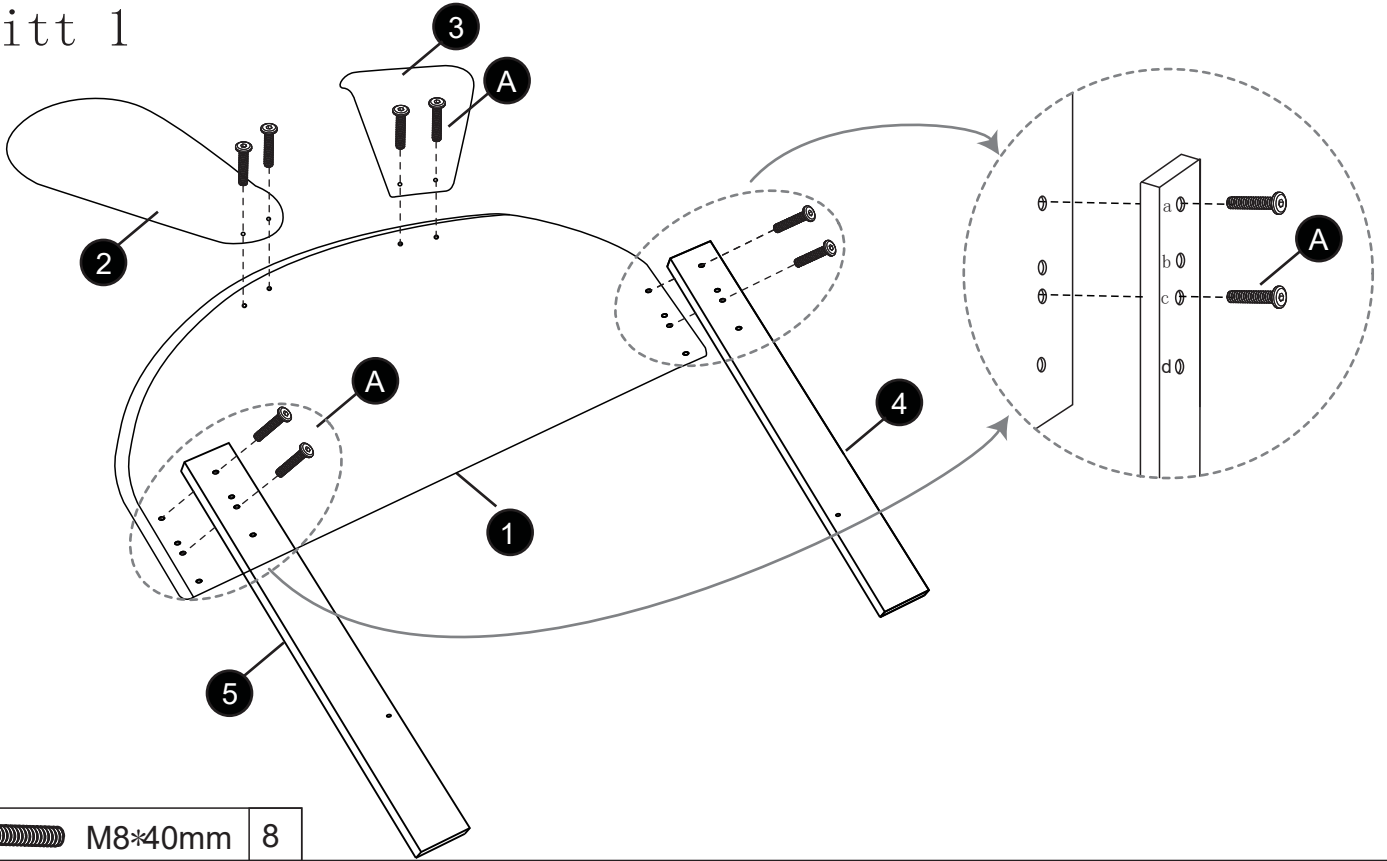

Schritt 1

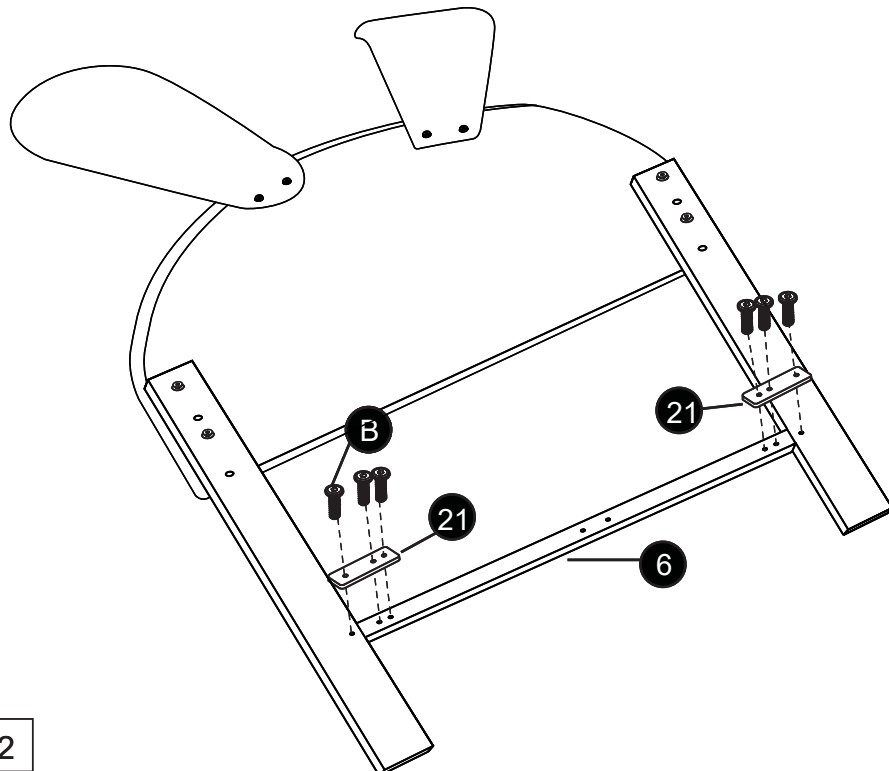

A		M8*40mm	8
---	---	---------	---

Schritt 2





21			2
B		M8*20mm	6

Schritt 3

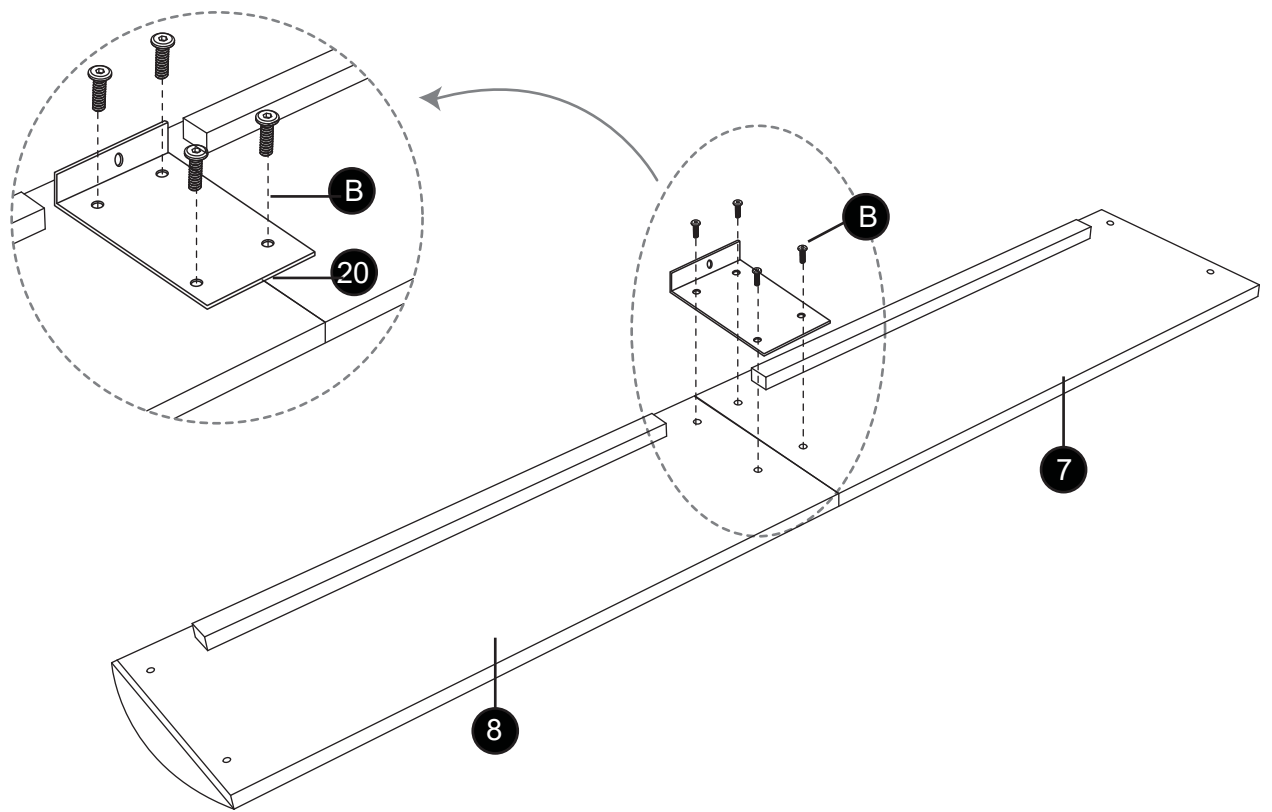
Left





20		1
B	 M8*20mm	4

Schritt 4

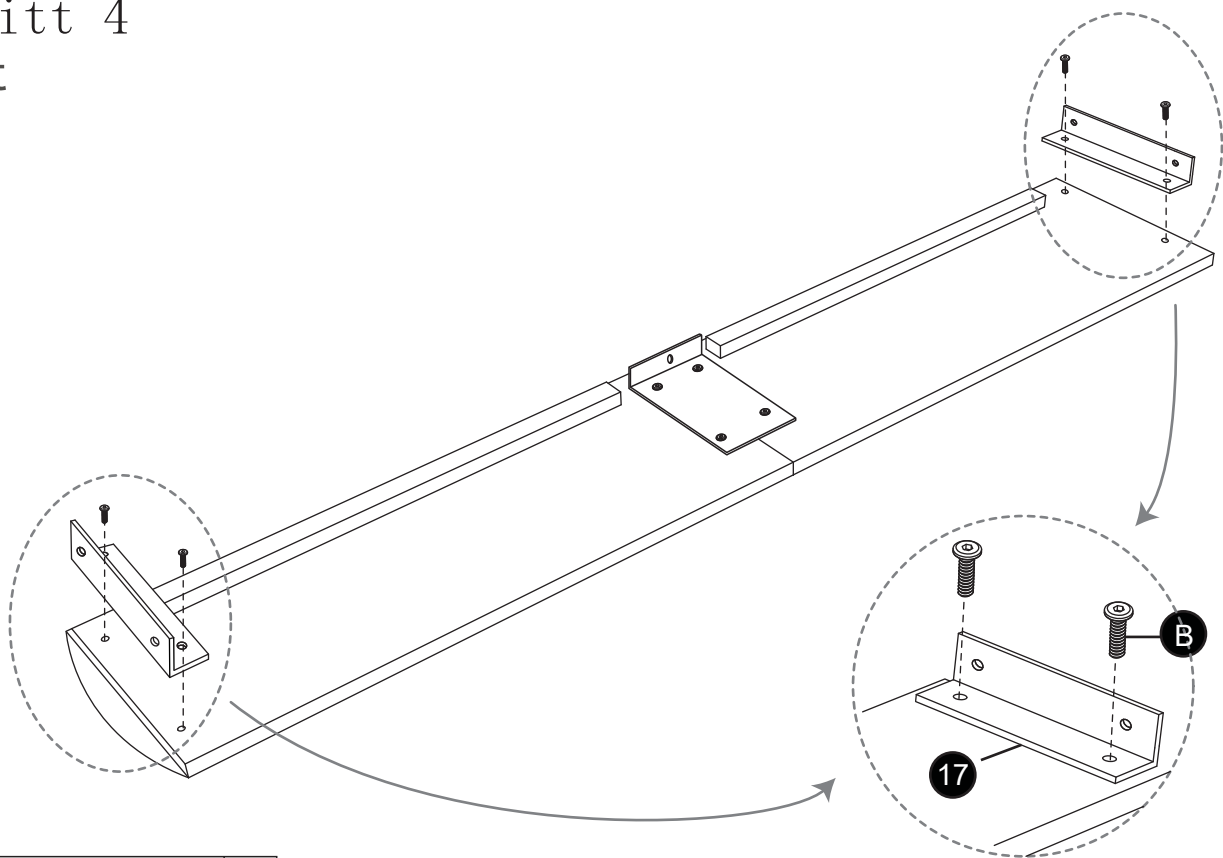

Left



17		2
B	 M8*20mm	4

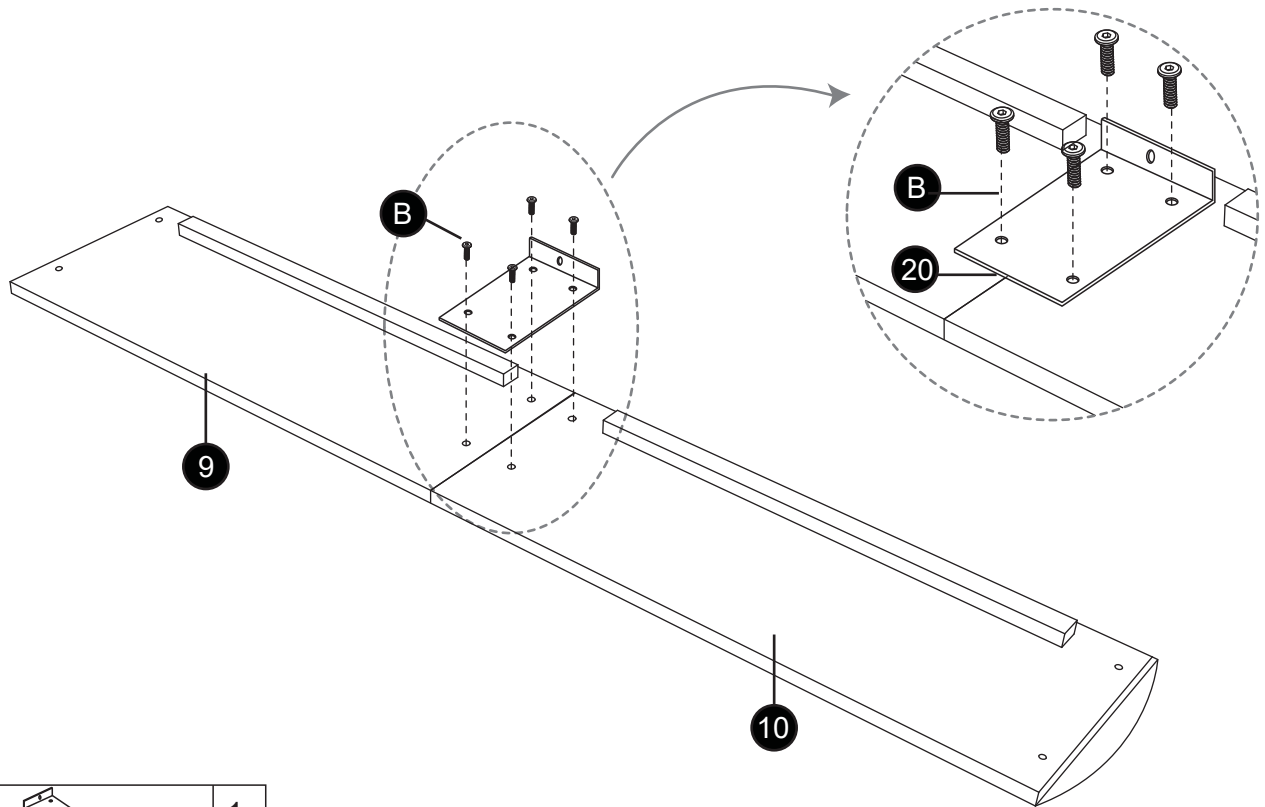

Schritt 5 Right

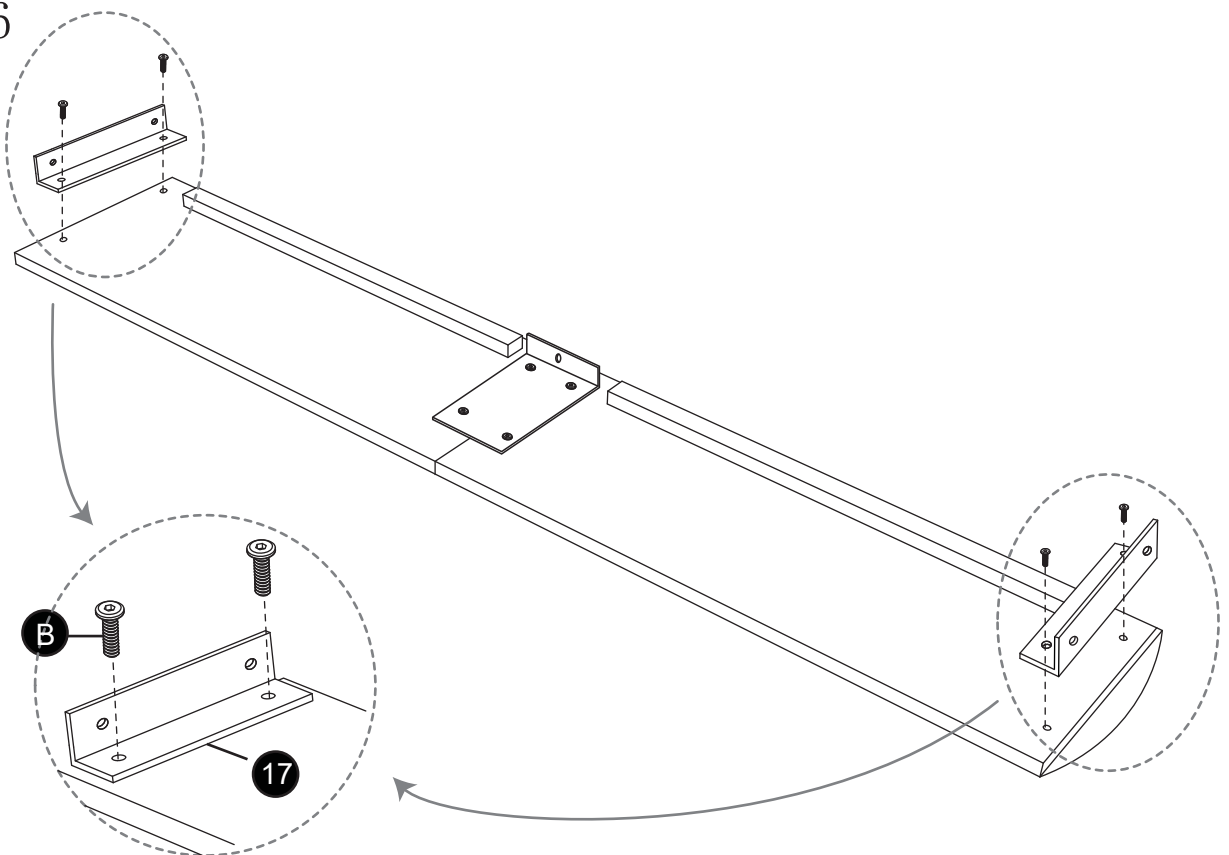

20		1
B	 M8*20mm	4

Schritt 6 Right



17		2
B	 M8*20mm	4

Schritt 7

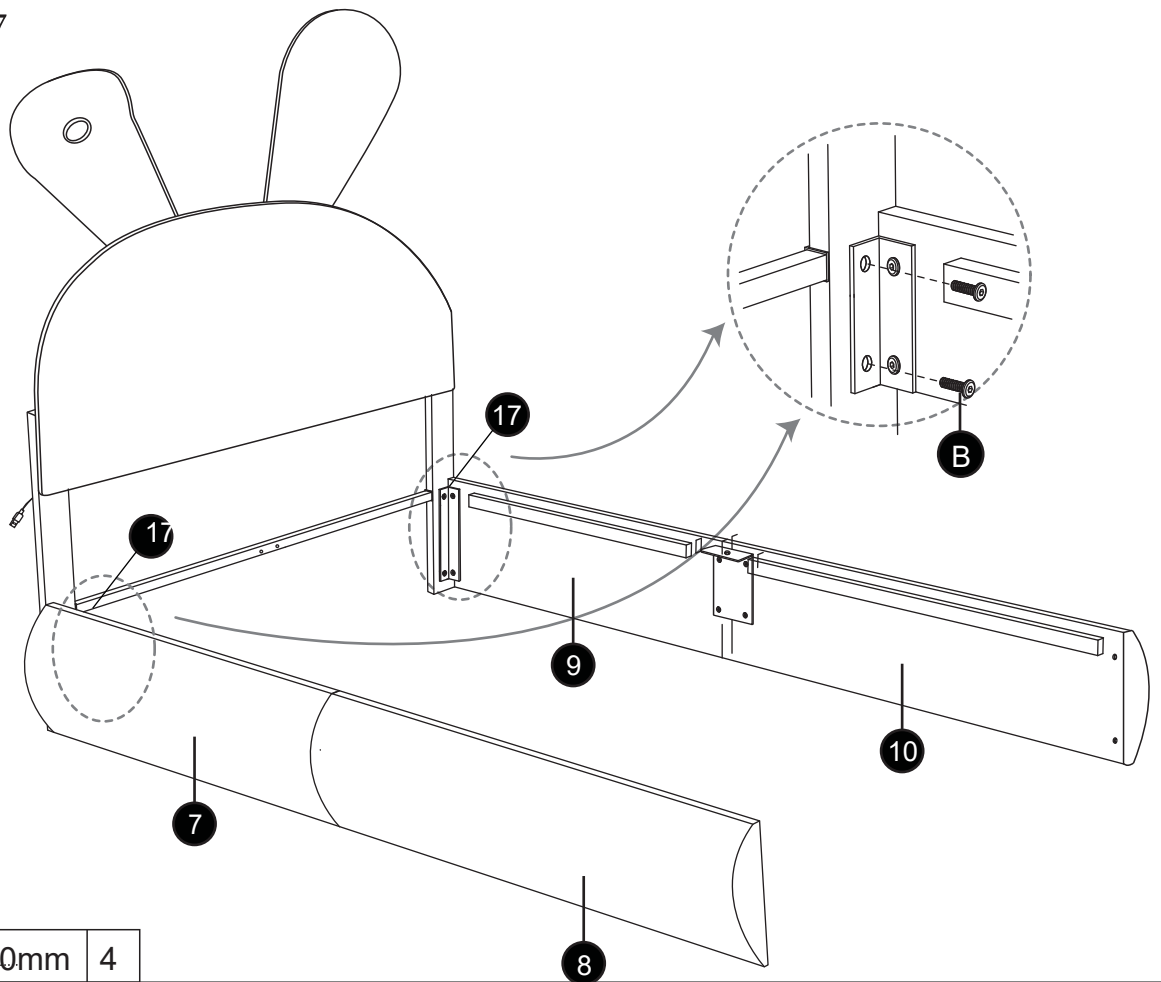

B  M8*20mm 4

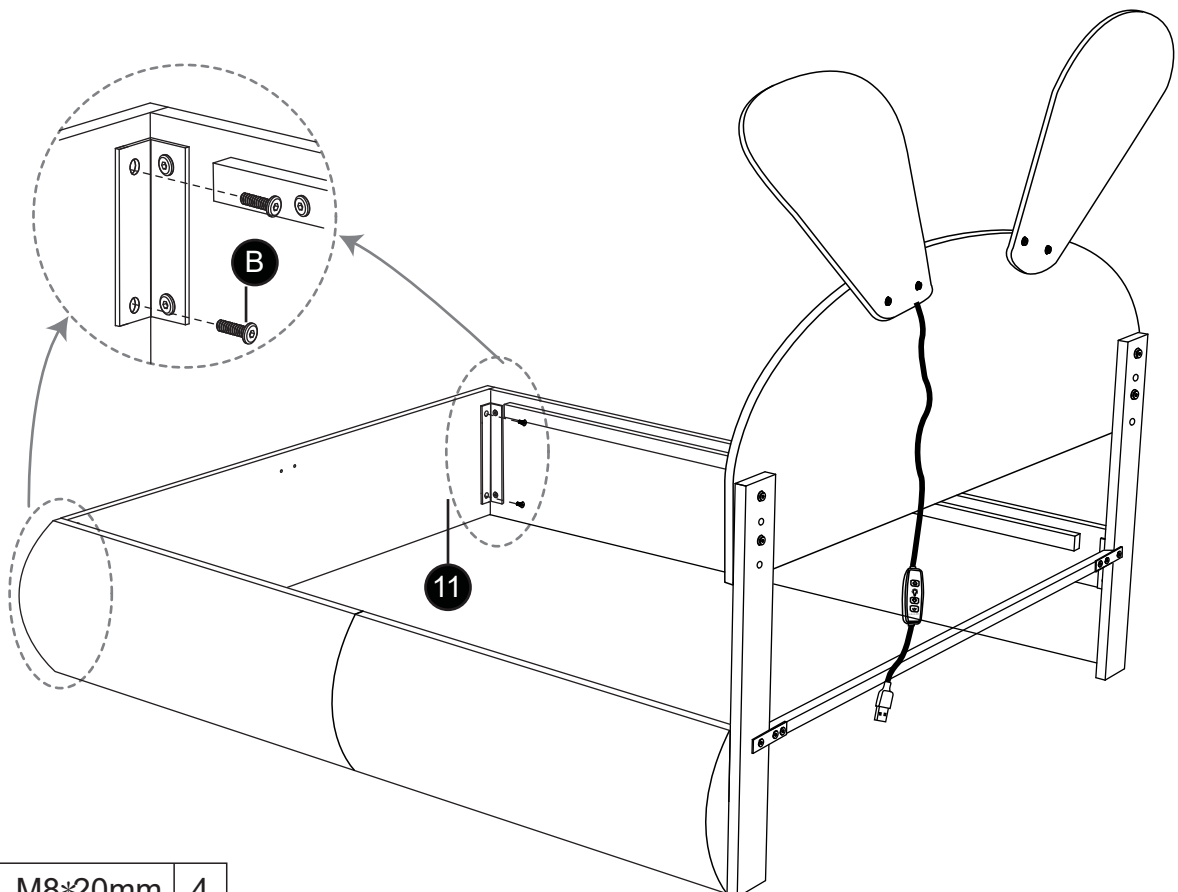

Schritt 8

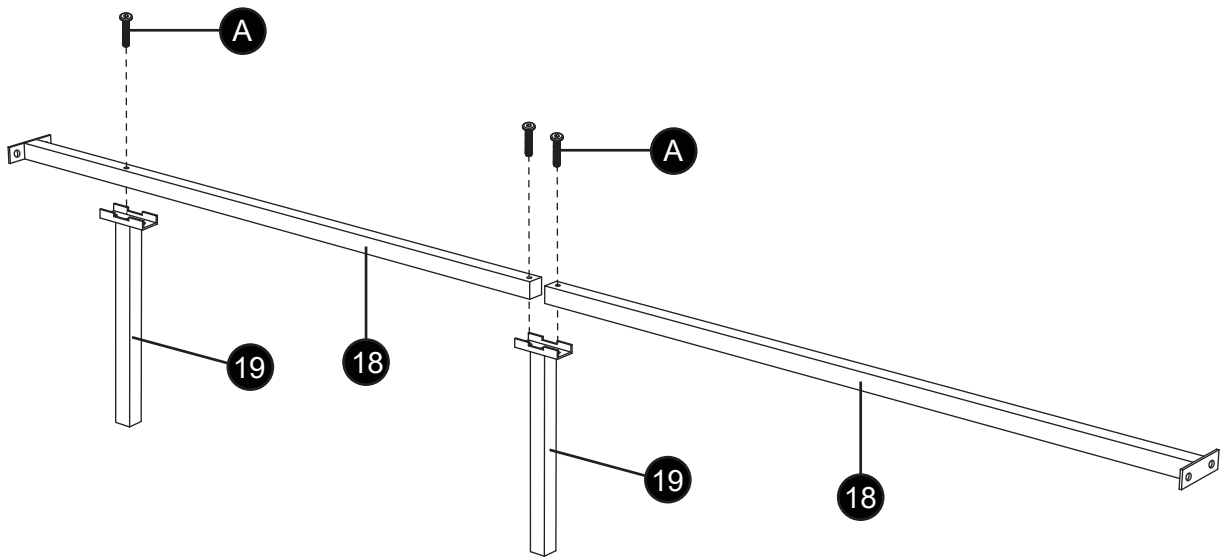

B  M8*20mm 4

Schritt 9



19		2
A	 M8*40mm	3

Schritt 10

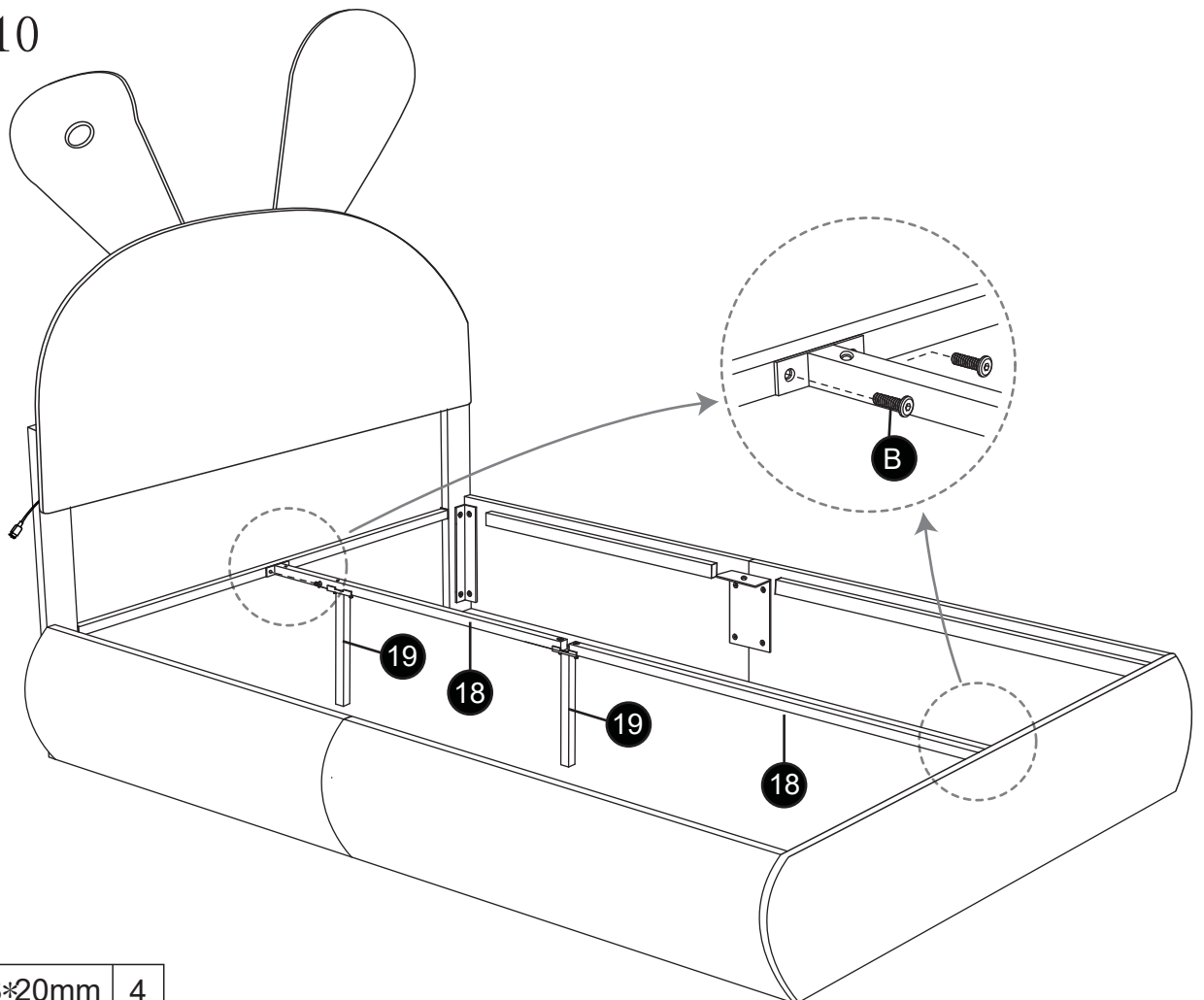

B	 M8*20mm	4
---	---	---

Schritt 11

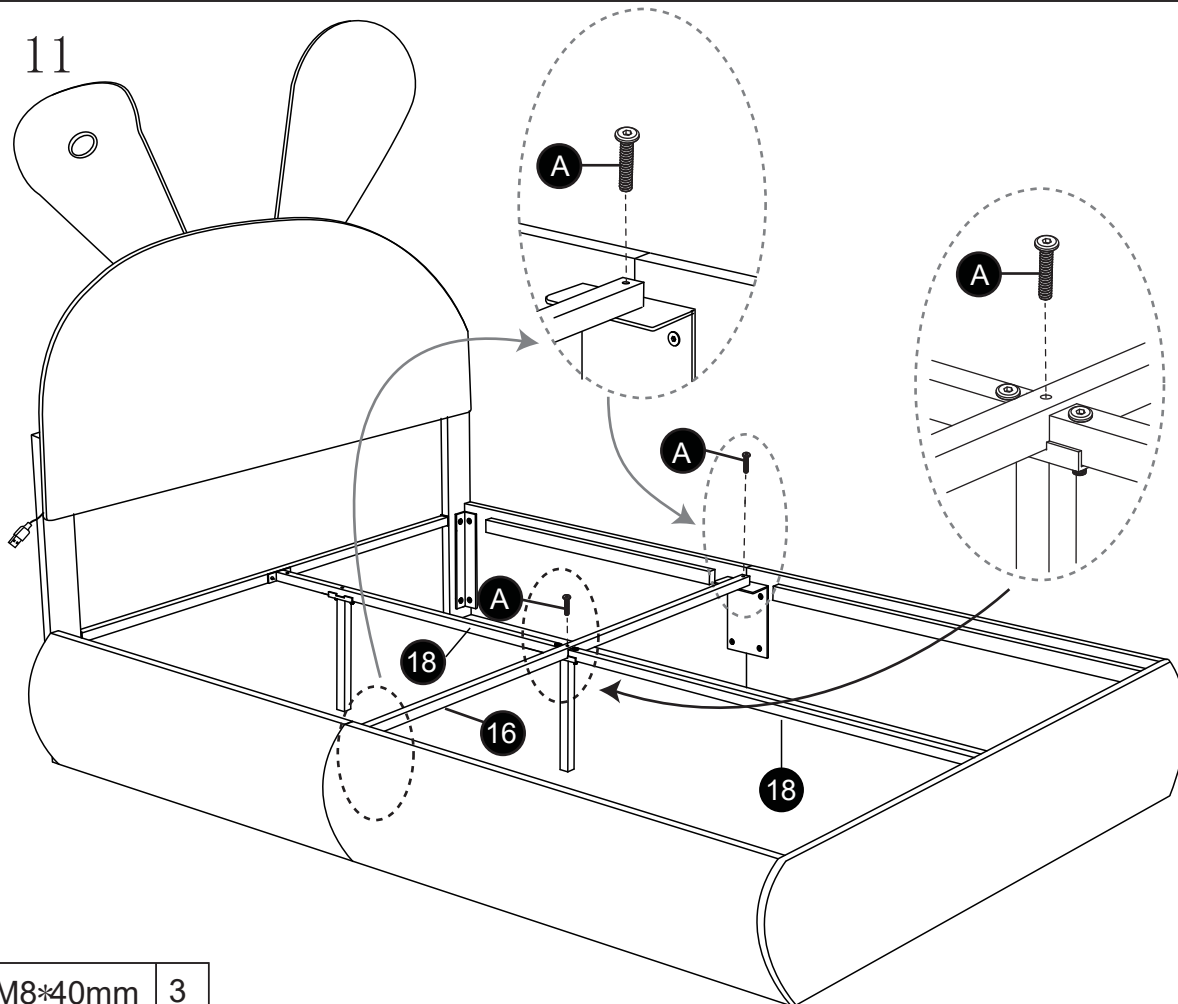

A  M8*40mm 3

Schritt 12

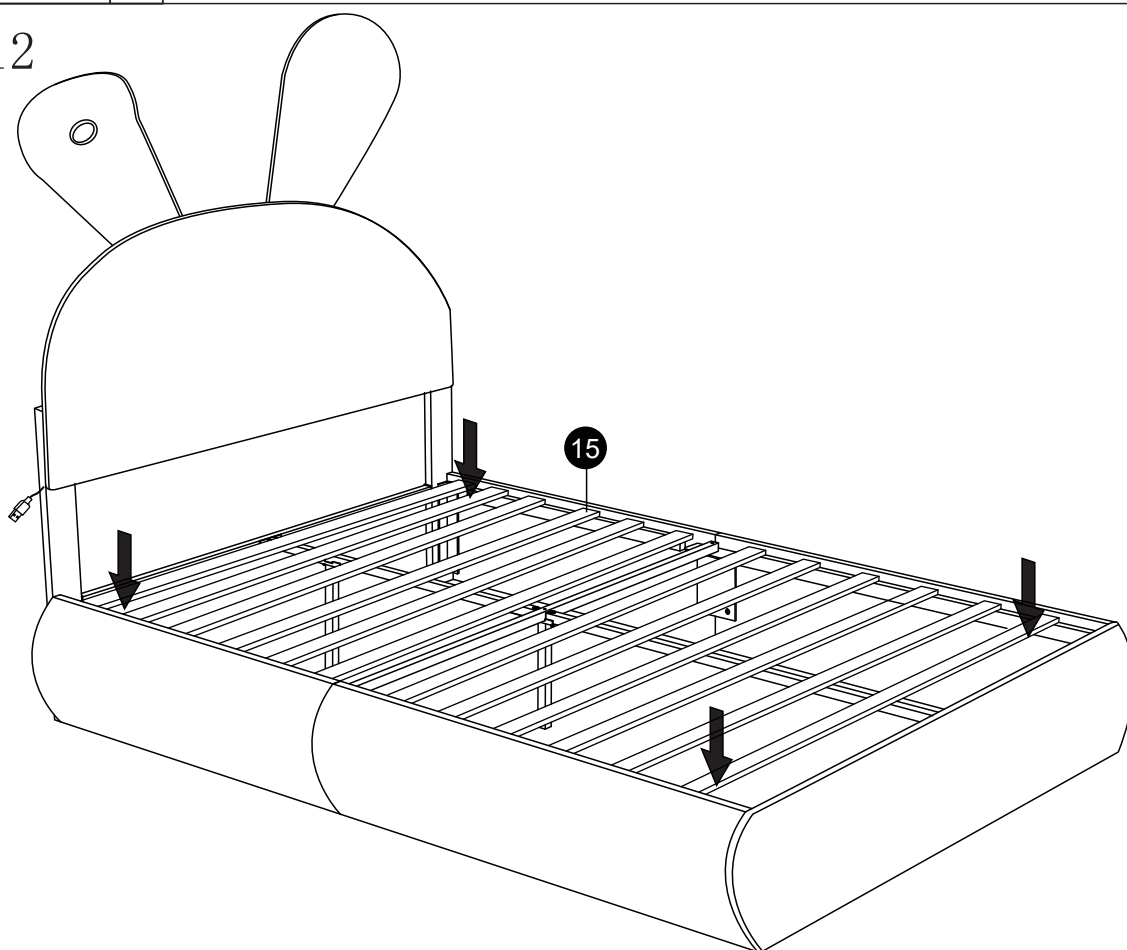

Schritt 13

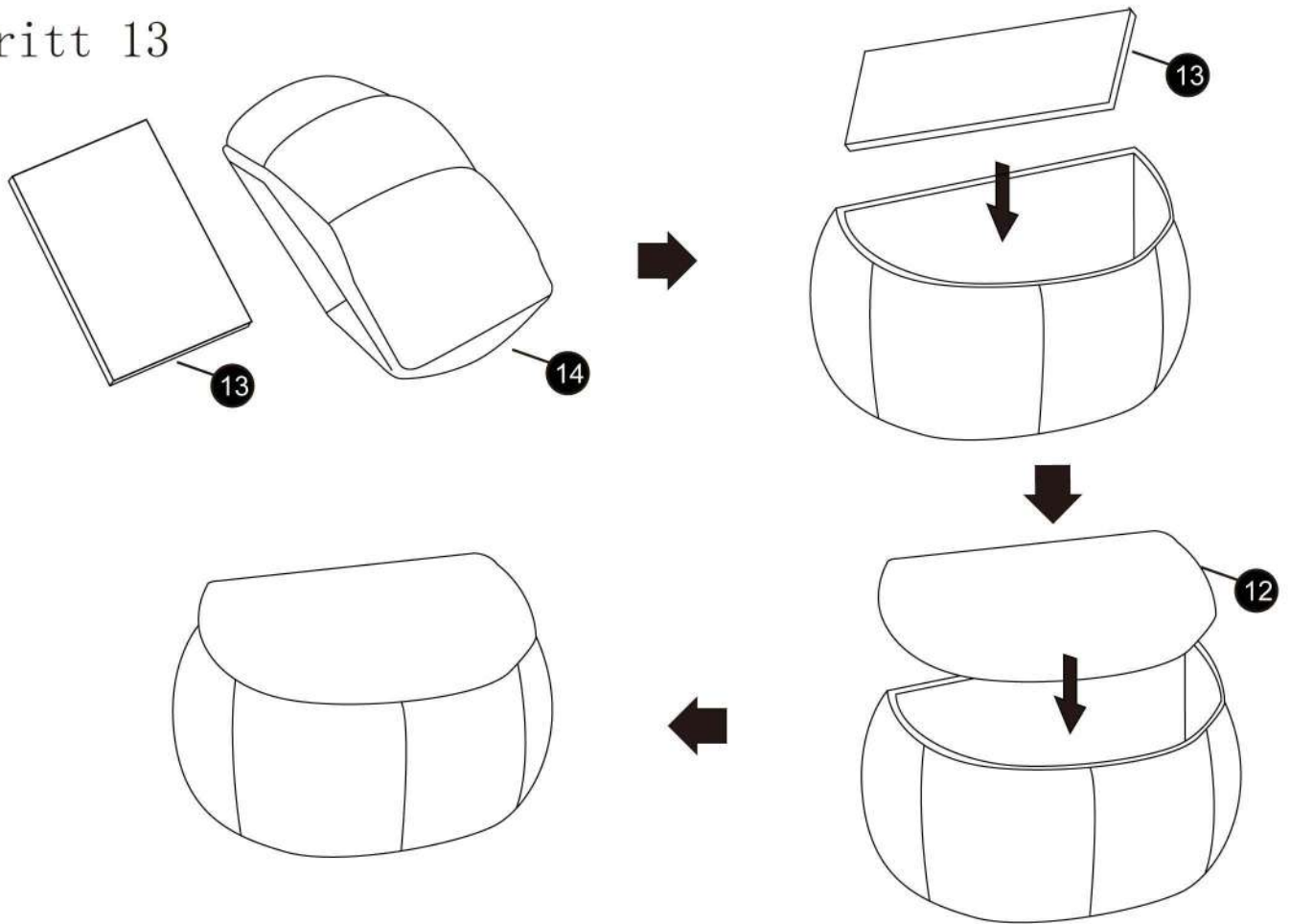

Schritt 14

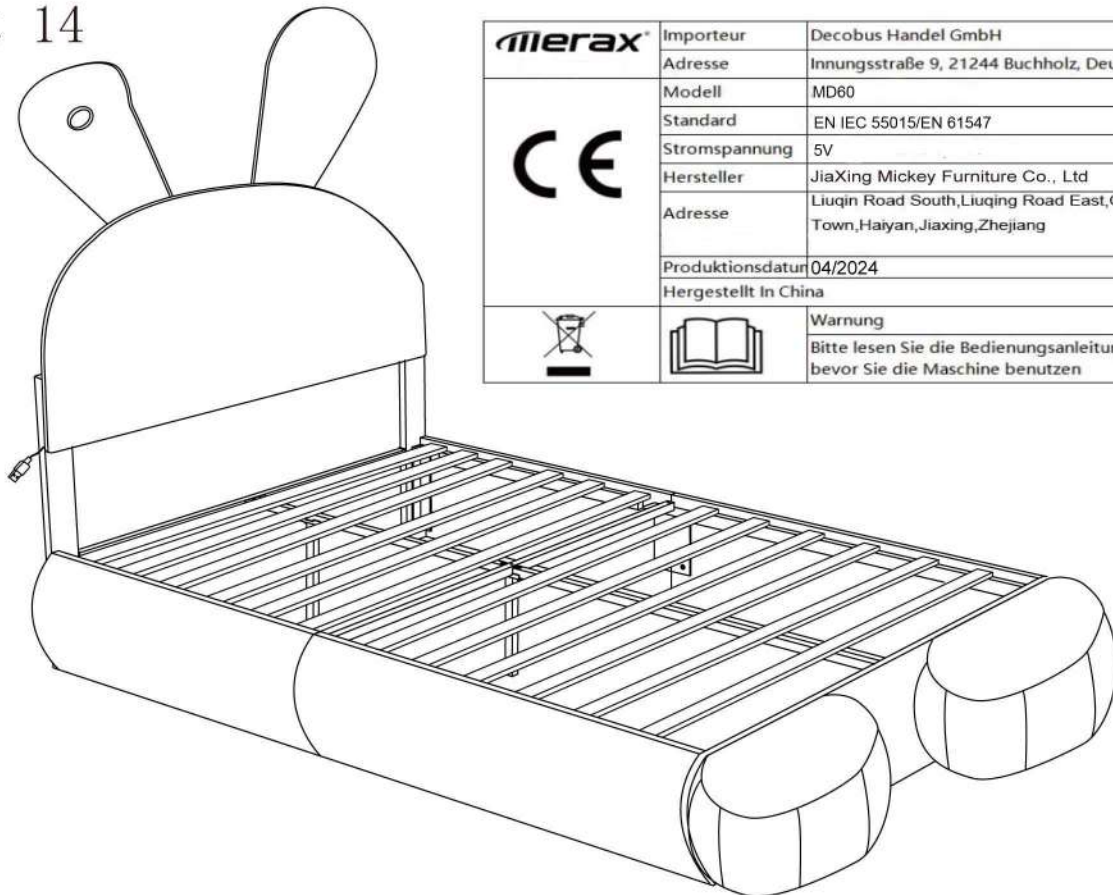

	ilerax	Importeur	Decobus Handel GmbH
		Adresse	Innungsstraße 9, 21244 Buchholz, Deutschland
		Modell	MD60
		Standard	EN IEC 55015/EN 61547
		Stromspannung	5V
		Hersteller	JiaXing Mickey Furniture Co., Ltd
		Adresse	Liuqin Road South, Liuqing Road East, Ganpu Town, Haiyan, Jiaxing, Zhejiang
		Produktionsdatum	04/2024
	Hergestellt In	China	
		Warnung	
		Bitte lesen Sie die Bedienungsanleitung sorgfältig durch, bevor Sie die Maschine benutzen	

Certificate

Certificate Number: UNIA22022135EC-11



Product: Ultrathin cabinet light
Applicant: Foshan Wei Guang Te Lighting Technology Co.,Ltd.
No.177, Bai'an South Road, Cangmen community Jun'an Town, Shunde District, Foshan City, Guangdong Province, China
Manufacturer: Foshan Wei Guang Te Lighting Technology Co.,Ltd.
No.177, Bai'an South Road, Cangmen community Jun'an Town, Shunde District, Foshan City, Guangdong Province, China
Model No.: MD60, MD45, MD70, MD80
Trade Name: N/A
Test Methods: EN IEC 55015:2019/A11:2020
EN 61547:2009

The laboratory tested the product provided by the applicant according to the above test methods. According to the test results, the product conforms to EMC Directive (2014/30/EU) issued by the European Commission. It is possible to use CE marking to demonstrate the compliance with EMC Directive.

The certificate applies to the tested sample above mentioned only and shall not imply an assessment of the whole production. It is only valid in connection with the test report number: UNIA22022135ER-11.

Mar. 04, 2022
Issue Date



Shenzhen United Testing Technology Co., Ltd.

Shenzhen: 2/F., Annex Building, Jiahuangyuan Tech Park, No.365, Baotian 1st Road, Tiegang, Xixiang Street, Bao'an District, Shenzhen, Guangdong, China/518050

Guangzhou: No 47-3, Industrial Road, Zhushan, Dalong Street, Panyu District, Guangzhou, Guangdong, China/511450

Tel: +86-755-86180996/+86-020-39277769 Fax: +86-0755-86180156

Web Site: www.uni-lab.hk/ E-mail: hofferlau@uni-lab.hk



Certificate of Compliance