

HPL 2

V.7

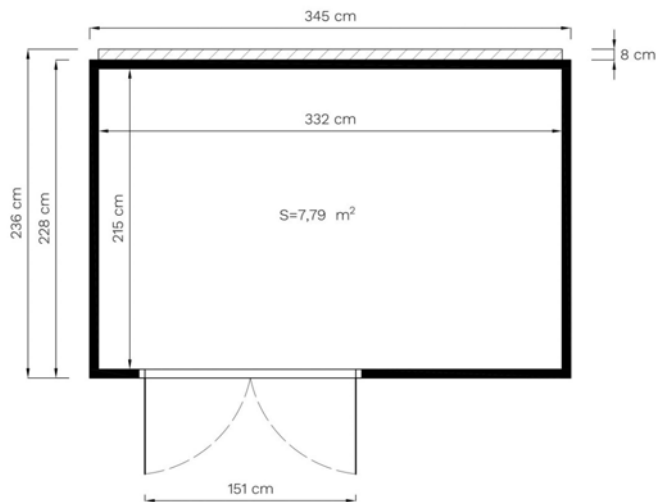
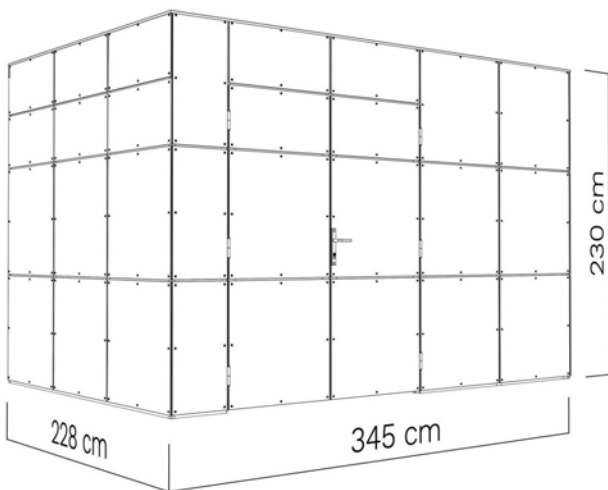

DE - Technische Änderungen vorbehalten.

Alle Maße sind ca. Maße.

EN - Technical modifications reserved.

All dimensions are approximate dimensions.



HPL 2

DE Bevor Sie beginnen

• Es ist empfehlenswert sich etwas Zeit zu nehmen, um die Aufbauanleitung anzusehen, bevor mit dem Aufbau begonnen wird. • Alle Schritte für den Aufbau werden – auch in Detailbildern – dargestellt. • Die vorgegebene Reihenfolge ist zu beachten. • Bitte prüfen Sie vor dem Aufbau anhand der Teileliste die Vollständigkeit und den Zustand der Lieferung. • Besonders wichtig ist der Holzschutz! Die Boden-elemente sind vor dem Aufbau von unten mit einem geeigneten Holzschutz zu behandeln! • Das für die meisten Produkte online verfügbare Datenblatt bietet weitere wichtige Hinweise für den Aufbau. • Beigefügt sind auch die Garantiebedingungen.

FR Avant de commencer

• il est recommandé de prendre le temps de lire les instructions de montage avant de commencer. • Toutes les étapes du montage sont présentées, y compris sur des illustrations détaillées. • L'ordre prescrit doit être respecté. • Avant le montage, vérifiez l'exhaustivité et l'état de la livraison à l'aide de la liste des pièces. • La protection du bois est particulièrement importante! Avant le montage, les éléments de plancher doivent être traités par le bas avec un produit de protection du bois approprié! • La fiche technique disponible en ligne pour la plupart des produits fournit d'autres informations importantes pour le montage. • Les conditions de garantie y sont également jointes.

CZ Než začnete

• Doporučujeme, abyste si vzali trochu času k prohlédnutí montážního návodu, než s montáží začnete. • Všechny montážní kroky jsou zobrazeny – také na podrobných obrázcích. • Je nutné dodržovat uvedený postup. • Před montáží zkontrolujte podle seznamu dílů, zda jste obdrželi všechny díly a zda je dodávka v dobrém stavu. • Obzvlášť důležitá je dřevěná botka! Podlahové prvky musí být před montáží zespoda ošetřeny vhodným ochranným přípravkem na dřevo! • Datový list, který je k dispozici online pro většinu produktů, poskytuje další důležité pokyny k montáži. • V příloze naleznete také záruční podmínky.

DK Før du starter

• Det kan anbefales at tage sig tid til at kigge på samlevejledningen, før du starter samlingen. • Alle trin i samlingen bliver vist – også i detaljerede billeder. • Overhold den angivne rækkefølge. • Kontrollér, at leveringen er fuldstændig og i den rette tilstand ved hjælp af delelisten, før du starter samlingen. • Særligt vigtig er træbeskyttelsen! Gulvelementerne skal behandles med egnet træbeskyttelse nedefra, før du starter samlingen! • Til de fleste produkter kan du finde datablade online, der indeholder yderligere vigtige informationer til samlingen. • Garantibetingelserne er også vedlagt.

NL Voordat u begint

• Het is aan te bevelen om de tijd te nemen om de opbouwhandleiding door te nemen voordat er met het opbouwen wordt begonnen. • Alle stappen voor het opbouwen worden – ook met gedetailleerde afbeeldingen – weergegeven. • Neem de aangegeven volgorde in acht. • Controleer voor het opbouwen aan de hand van de onderdelenlijst de volledigheid en de hoedanigheid van de levering. • Bijzonder belangrijk is de bescherming van het hout! De vloerelementen moeten voor het opbouwen van onderen met een geschikt houtbeschermingsmiddel worden behandeld! • Het voor de meeste producten online beschikbare gegevensblad bevat verdere belangrijke aanwijzingen voor de opbouw. • Bijgevoegd zijn ook de

PL Przed rozpoczęciem

• Wskazane jest, aby przed przystąpieniem do montażu zapoznać się z instrukcją montażu. • Pokazane są wszystkie etapy montażu – również na szczegółowych zdjęciach. • Należy przestrzegać podanej kolejności. • Przed montażem należy skorzystać z listy części, aby sprawdzić, czy dostawa jest kompletna i w dobrym stanie. • Ochrona drewna jest szczególnie ważna! Przed montażem elementy podłogowe należy zabezpieczyć od dołu odpowiednim środkiem do konserwacji drewna! • Arkusz danych, który jest dostępny online dla większości produktów, zawiera dalsze ważne informacje dotyczące montażu. • Załączone są również warunki gwarancji.

SV Innan du börjar

• Vi rekommenderar att du åsidosätter lite tid för att titta igenom monteringsanvisningen innan du påbörjar monteringen. • Alla monteringsstegen visas – även med detaljerade bilder. • Den angivna ordningen måste följas. • Kontrollera att leveransen är komplett och i gott skick innan monteringen påbörjas med hjälp av listan över delar. • Träskyddet är av yttersta vikt! Golvelementen ska behandlas underifrån med lämpligt träskyddsmedel före monteringen! • Annan viktig information före montering finns i databladet (tillgängligt online för de flesta produkter). • Garantivillkoren bifogas också.

RO Înainte să începeți

• Vă recomandăm să dedicați puțin timp pentru a consulta Instrucțiunile de asamblare înainte de a începe asamblarea. • Toate etapele de asamblare sunt prezentate amănunțit - și în forma unor figuri detaliate. • Respectați ordinea specificată. • Înainte de asamblare, vă rugăm să verificați lista de componente pentru a vă asigura că furnitura este completă și în stare bună. • Acordați o deosebită atenție protecției lemnului! Elementele de podea trebuie tratate de dedesubt cu o substanță conservantă adecvată pentru protecția lemnului înainte de asamblare! • Fișa de date, care este disponibilă și online pentru majoritatea produselor, oferă informații suplimentare importante cu privire la asamblare. • Atașat veți găsi și condițiile de garanție.











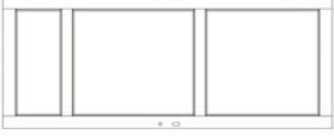

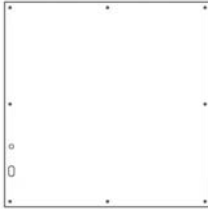











EE Soovitused enne paigalduse alustamist

• Soovitame enne paigalduse alustamist võtta aega ja tutvuda paigaldusjuhendiga. • Kõik kokkupaneku etapid on näidatud ka üksikasjalikel piltidel. • Paigaldustööd tuleks teha etteantud järjekorras. • Enne paigalduse alustamist kontrollige detailide nimekirja alusel, kas kõik elemendid on olemas ja ega need pole kahjustada saanud. • Puidukaitse on eriti oluline! Põrandaelemente tuleb enne kokkupanekut töödelda altpoolt sobiva puidukaitsevahendiga! • Andmeleht, mis on enamiku toodete kohta internetis saadaval, pakub kokkupanekuks täiendavat olulist teavet. • Lisatud on ka garantiitingimused.







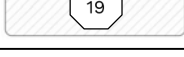
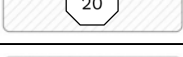
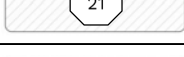
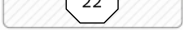
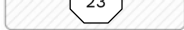



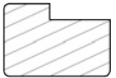







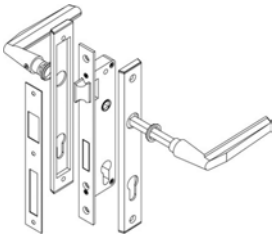



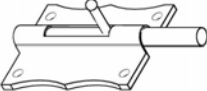
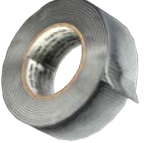

EN Before assembly

• We recommend that time is taken to read the assembly instructions prior to assembly. • All assembly steps are shown – also in detailed images. • The step-by-step instructions must be followed. • Before assembly, please use the parts list to check that all components are accounted for and in good condition. • Wood protection is particularly important! The floor elements must be treated from below with a suitable wood preservative before assembly! • The data sheet, which is available online for most products, offers further important information for assembly. • The guarantee conditions are also attached.

HPL 2

ID	Details in mm (Tolerance/Toleranz ...+ 2mm)	Pcs.	ID	Details in mm (Tolerance/Toleranz ...+ 2mm)	Pcs.
60	32 x 760 x 1893 	x 1	61	32 x 760 x 1893 	x 1
1059	6 x 754 x 754 TRESPA 	x 32	1060	6 x 754 x 754 TRESPA 	x 1
1061	6 x 654 x 754 TRESPA 	x 3	1062	6 x 654 x 754 TRESPA 	x 1
1063	6 x 372 x 754 TRESPA 	x 12	1081	6 x 372 x 654 TRESPA 	x 1
1029	28 x 80 x 2300 	x 21	1030	28 x 80 x 2268 	x 9
1031	28 x 80 x 2205 	x 6	1033	28 x 80 x 2161 	x 12
1034	28 x 80 x 1752 	x 1	1035	28 x 80 x 1442 	x 3
1036	28 x 80 x 1030 	x 8	1037	28 x 80 x 684 	x 28
1038	28 x 80 x 676 	x 4	1039	28 x 80 x 657 	x 19
1040	28 x 80 x 636 	x 4	1041	28 x 80 x 632 	x 4
1042	28 x 80 x 601 	x 3	1043	28 x 80 x 590 	x 2
1044	28 x 80 x 541 	x 6	1045	28 x 80 x 387 	x 3
1046	28 x 80 x 332 	x 5	1047	28 x 80 x 302 	x 4
1048	28 x 80 x 296 	x 3	1049	28 x 80 x 254 	x 4
1050	28 x 80 x 224 	x 8	1051	28 x 80 x 208 	x 1

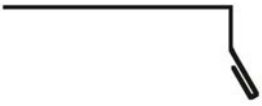
HPL 2

ID	Details in mm (Tolerance/Toleranz ...+ 2mm)	Pcs.	ID	Details in mm (Tolerance/Toleranz ...+ 2mm)	Pcs.
1052	28 x 80 x 136 	x 1	1053	40 x 60 x 1913 	x 2
1058	12 x 42 x 1894 	x 1	1064	6 x 372 x 754 PLEXIGLASS 	x 3
516	12 x 830 x 1150 MFP 	x 8	1561	MR2628 	x 1
1500	Ø5 x 120 	x 56	1505	Ø4,5 x 50 	x521
1506	Ø3,4 x 35 	x134	1560	Ø4,8 x 32 Grey/white Ø4,8 x 32 Anthrazite 	X392 X392
1531		x 1	1502	Ø4,5 x 75 	x 8
1554		x 1	828	28 x 28 x 1660 	x 2
1527		x 3	1570	38 x 65 x 2184 	x 1
1555		x 3	1571	38 x 65 x 1186 	x 1
1517		x 2	1559	EPDM 95 rm/lfm 	
1082	19 x 45 x 2000 	x 1	1100	19 x 45 x 560 	x 3
1101	10 x 10 x 754 	x 2	1565	Ø4 x 16 	x 4
1566	1 x 9 	x 4	1567	3 x 7 	x 4
1563	12 x 65 x 1175 	x 7	1564	Ø4,8 x 38 	x 29

HPL 2

Before assembly the shed, sort frame pieces by length!
 Vor dem Zusammenbauen sind die Holzteile der Länge nach zu sortieren!



1029	28 x 80 x 2300		x 21	1030	28 x 80 x 2268		x 9
1031	28 x 80 x 2205		x 6	1033	28 x 80 x 2161		x 12
1034	28 x 80 x 1752		x 1	1035	28 x 80 x 1442		x 3
1036	28 x 80 x 1030		x 8	1037	28 x 80 x 684		x 28
1038	28 x 80 x 676		x 4	1039	28 x 80 x 657		x 19
1040	28 x 80 x 636		x 4	1041	28 x 80 x 632		x 4
1042	28 x 80 x 612		x 4	1043	28 x 80 x 590		x 2
1044	28 x 80 x 541		x 6	1045	28 x 80 x 387		x 3
1046	28 x 80 x 332		x 5	1047	28 x 80 x 302		x 4
1048	28 x 80 x 296		x 3	1049	28 x 80 x 254		x 4
1050	28 x 80 x 224		x 8	1051	28 x 80 x 208		x 1

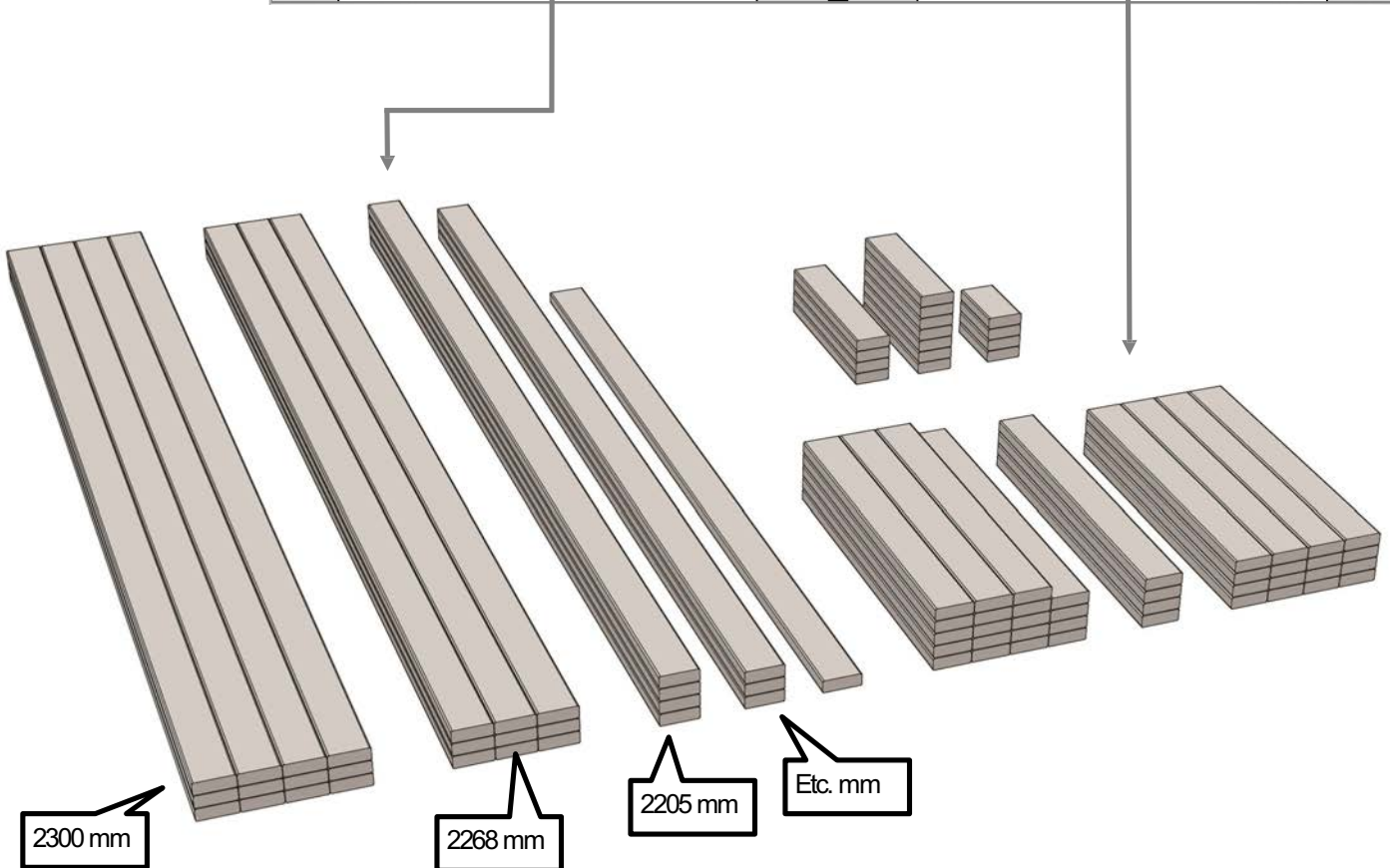

HPL 2

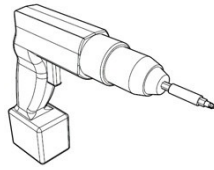
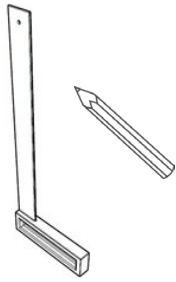

Ø 4mm
Ø 8mm

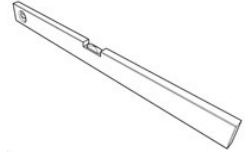

1.

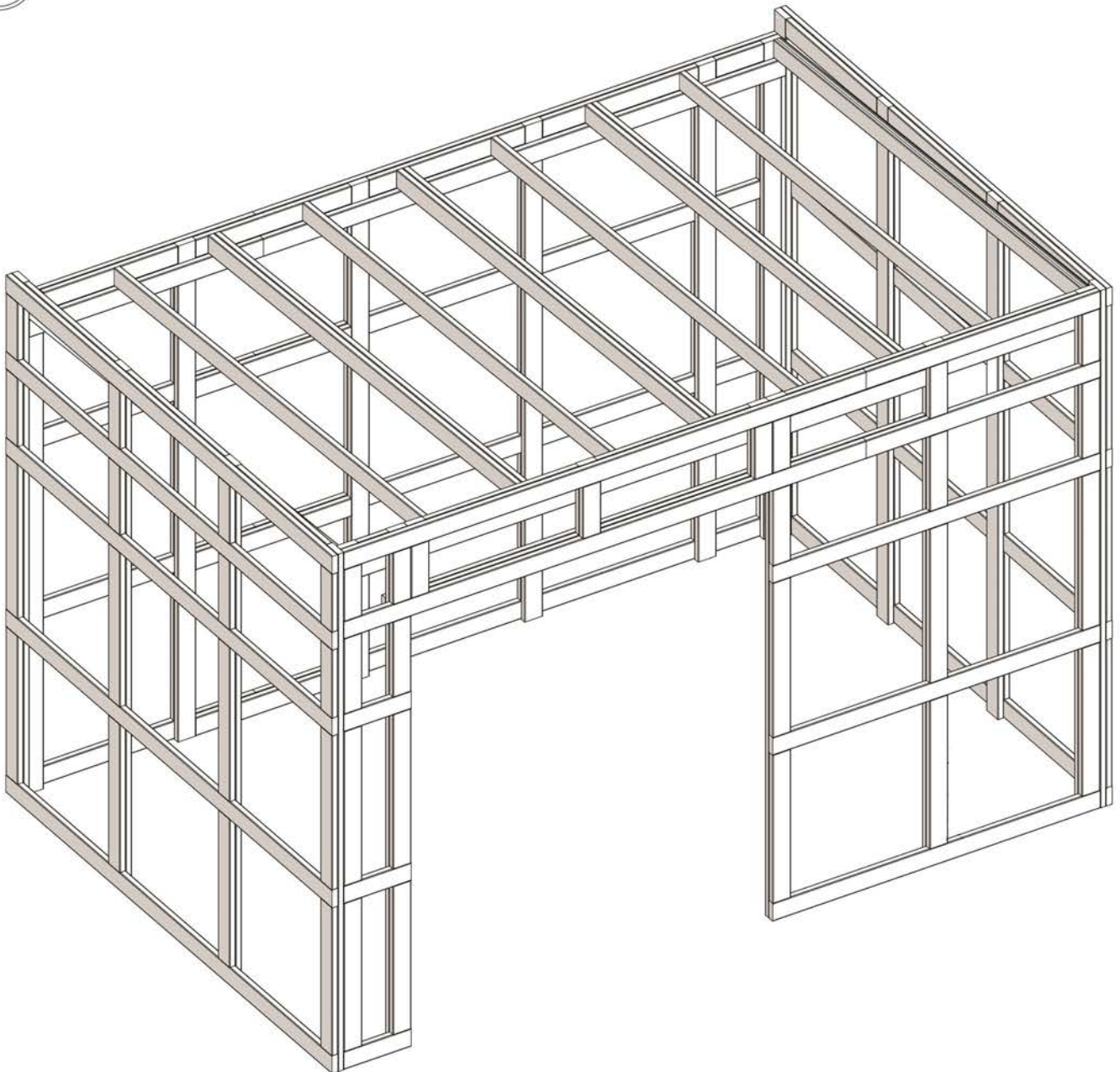

HPL 2



7 Hours



HPL 2

2.

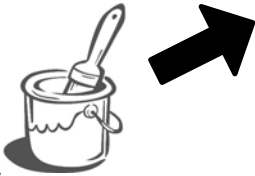
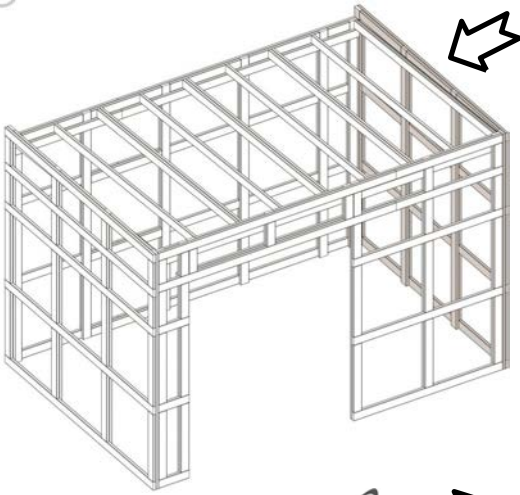

Holzschutzmittel / Wood preservative

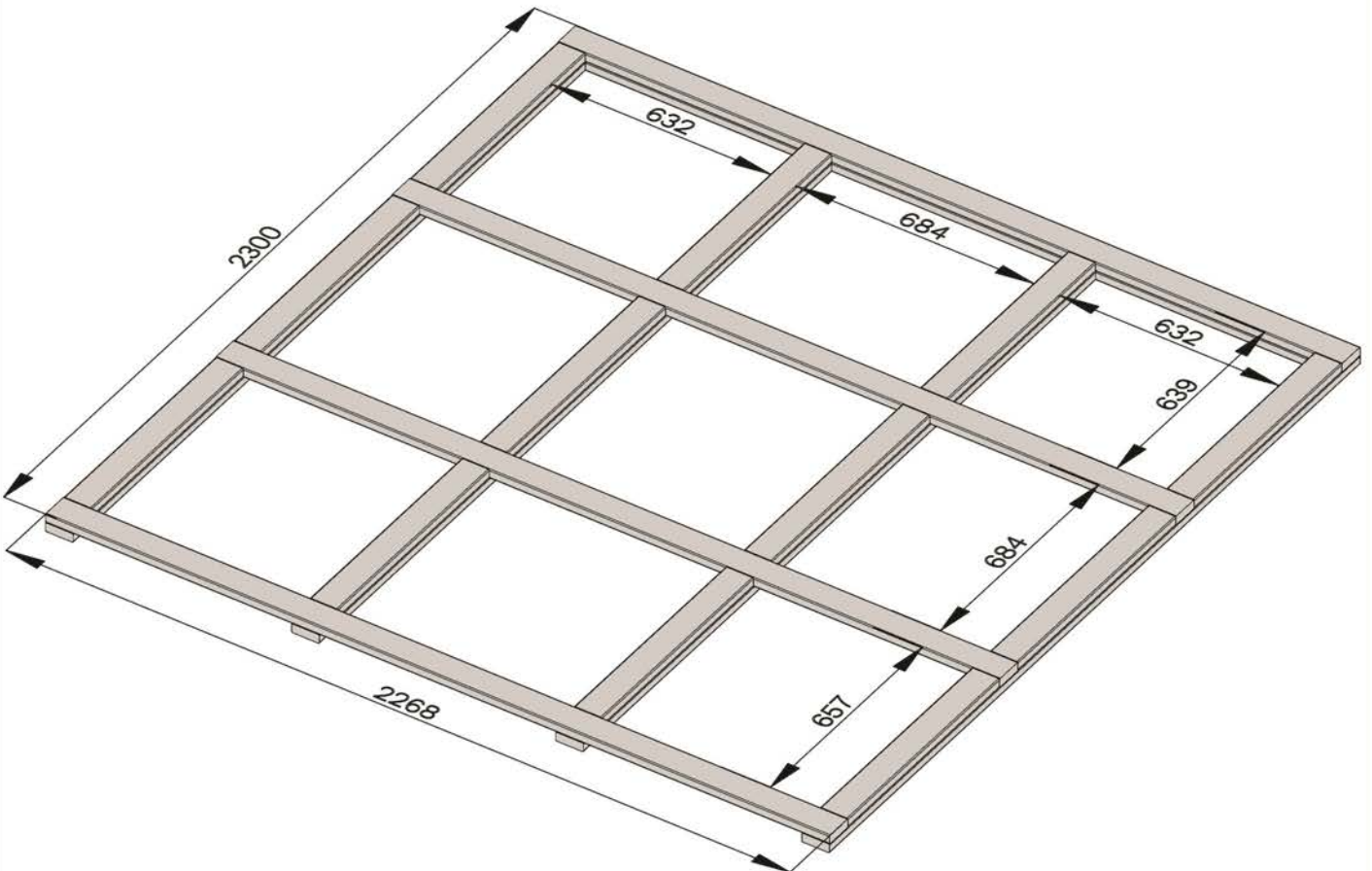
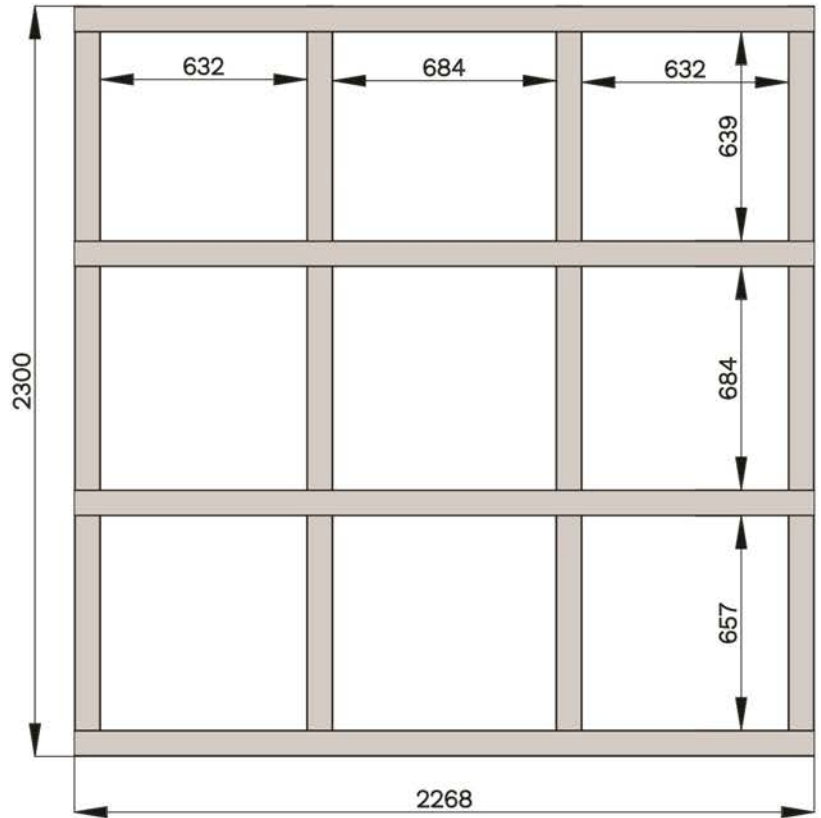

HPL 2

3.

A=B

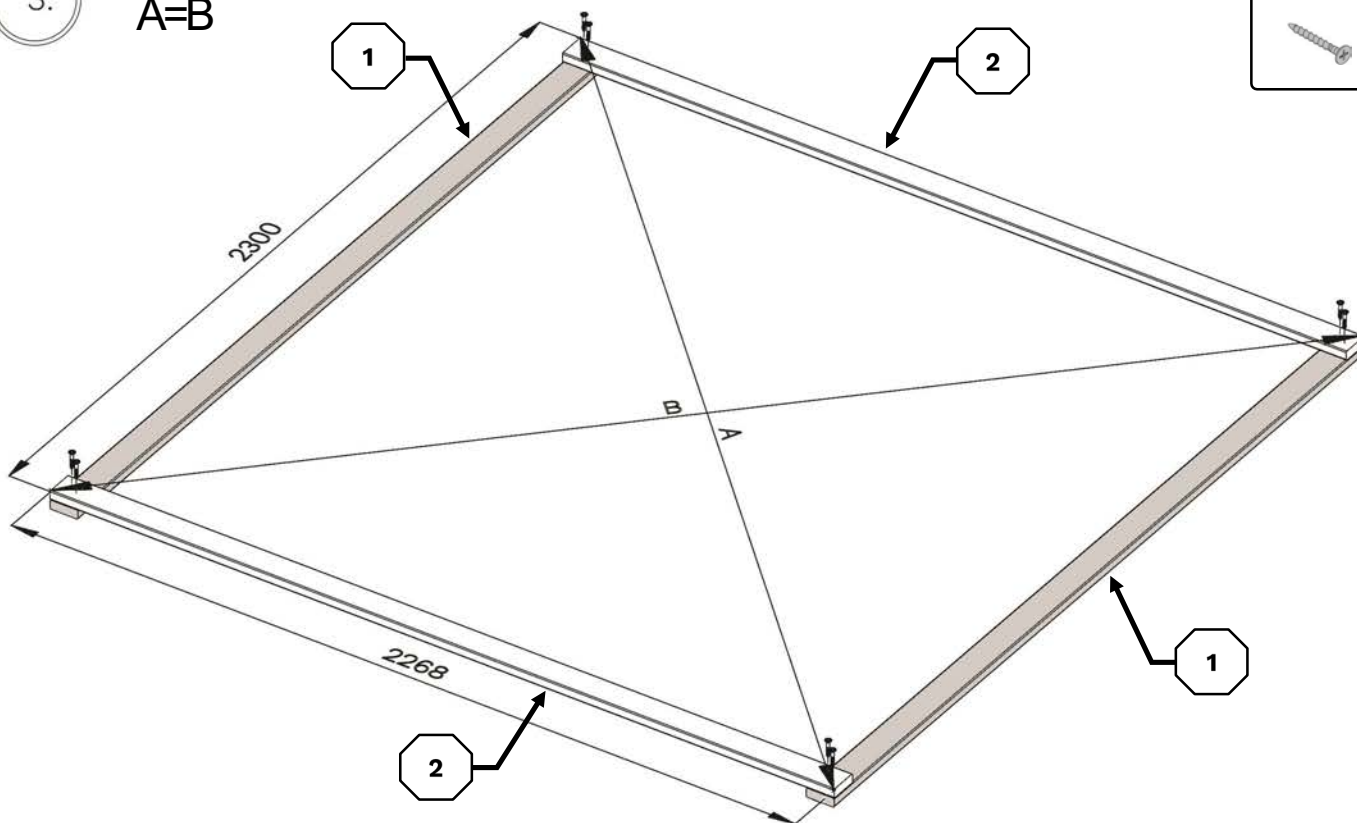

4.

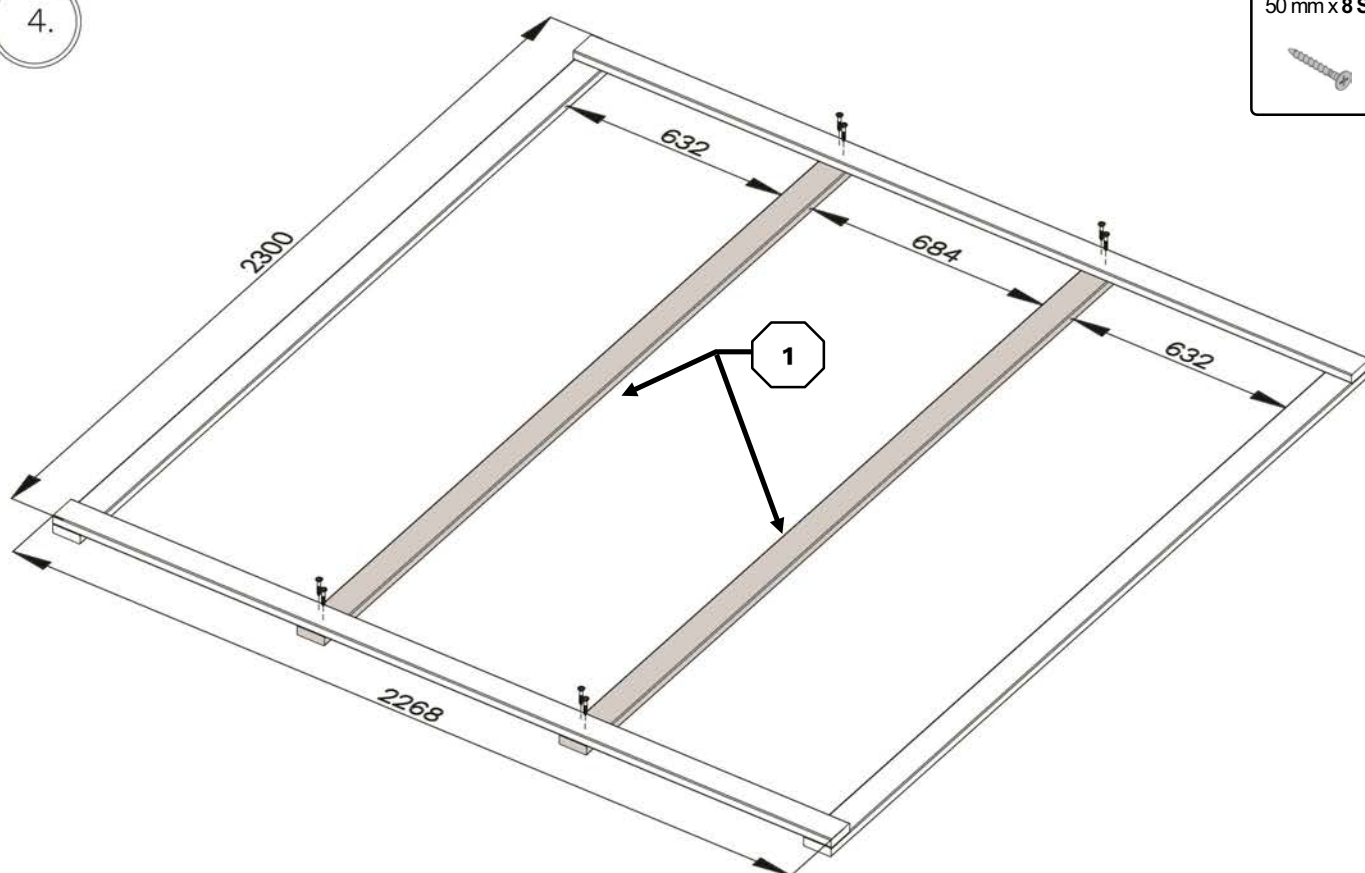

HPL 2

5.

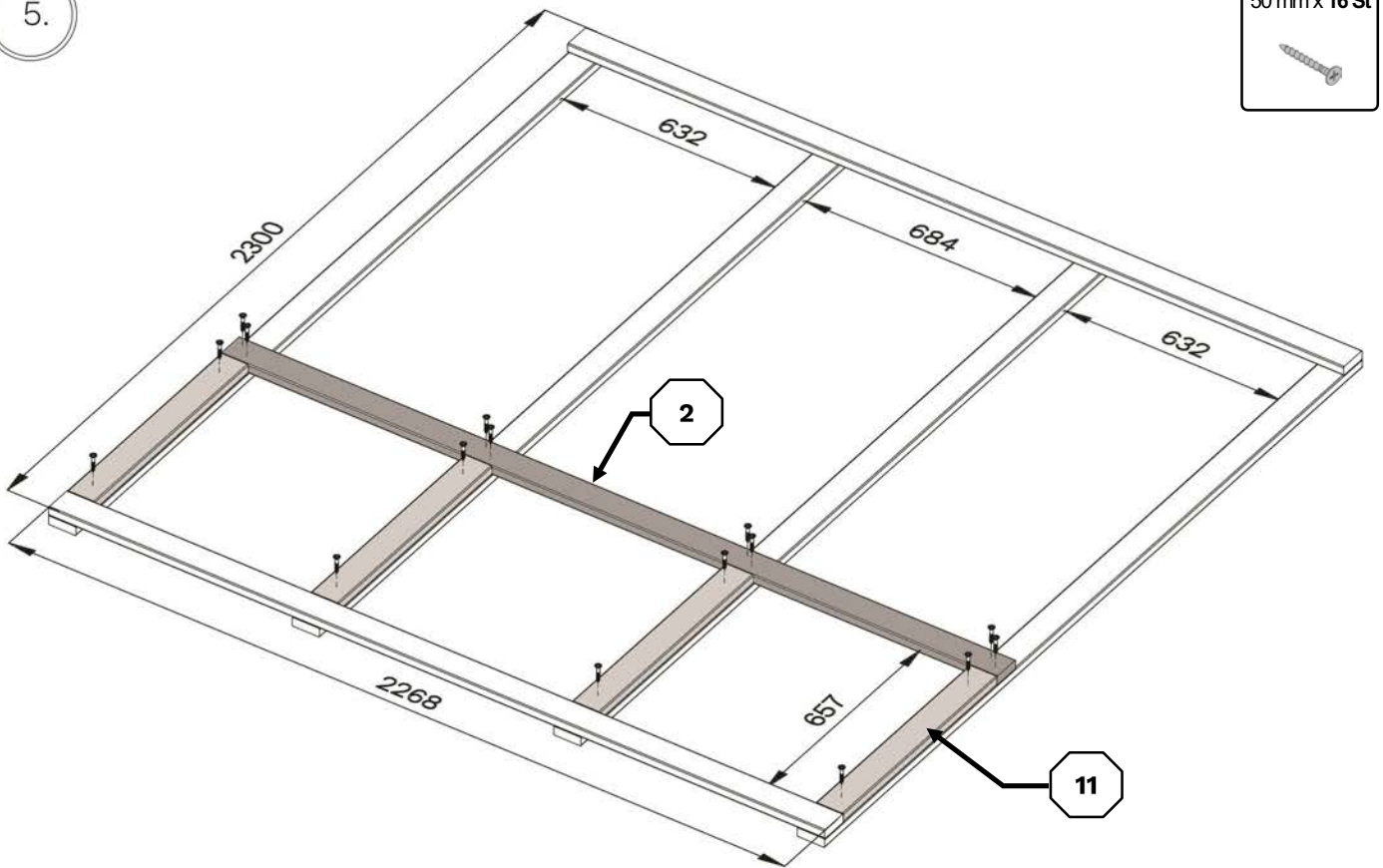

6.

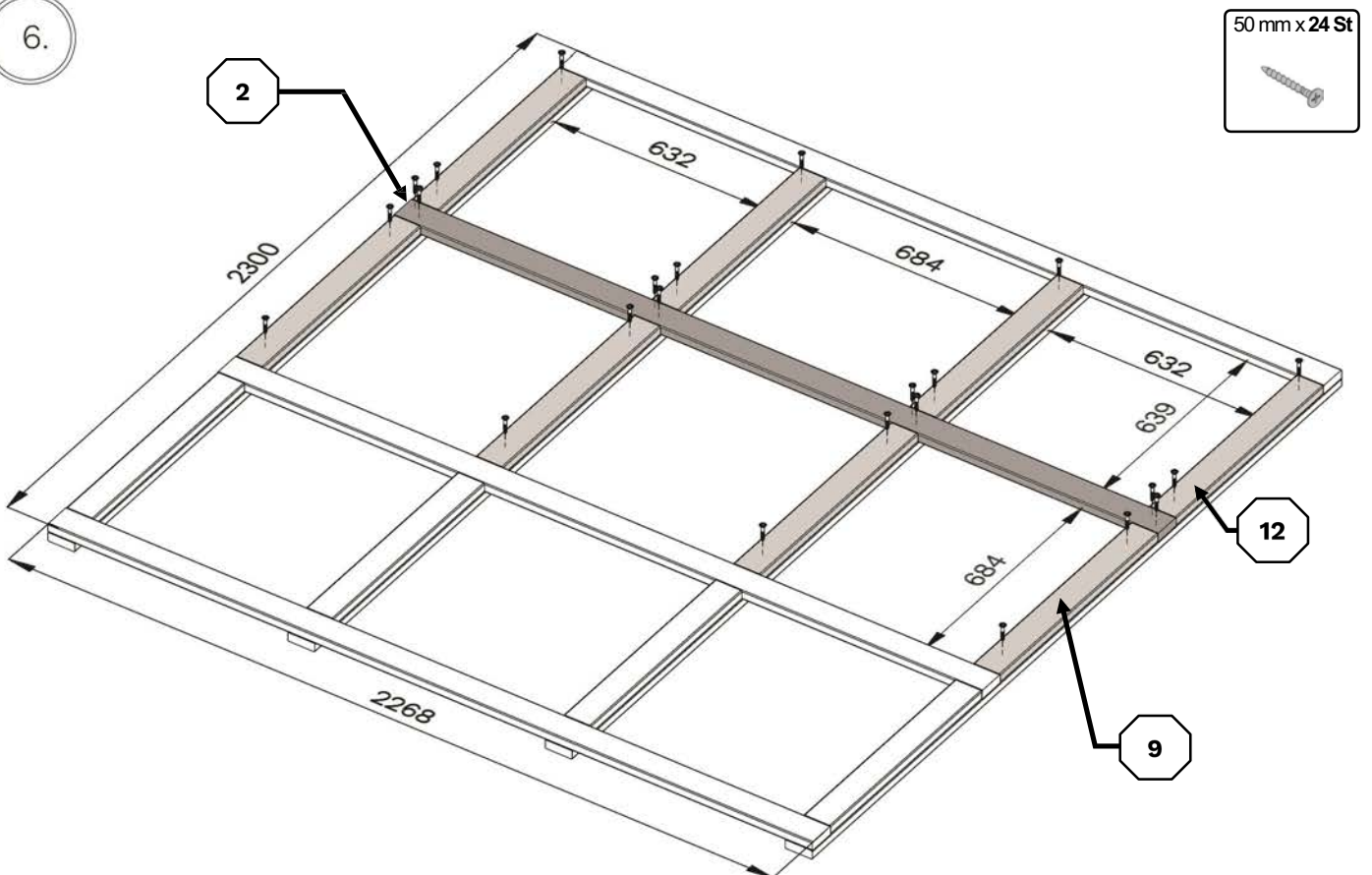

HPL 2

7.

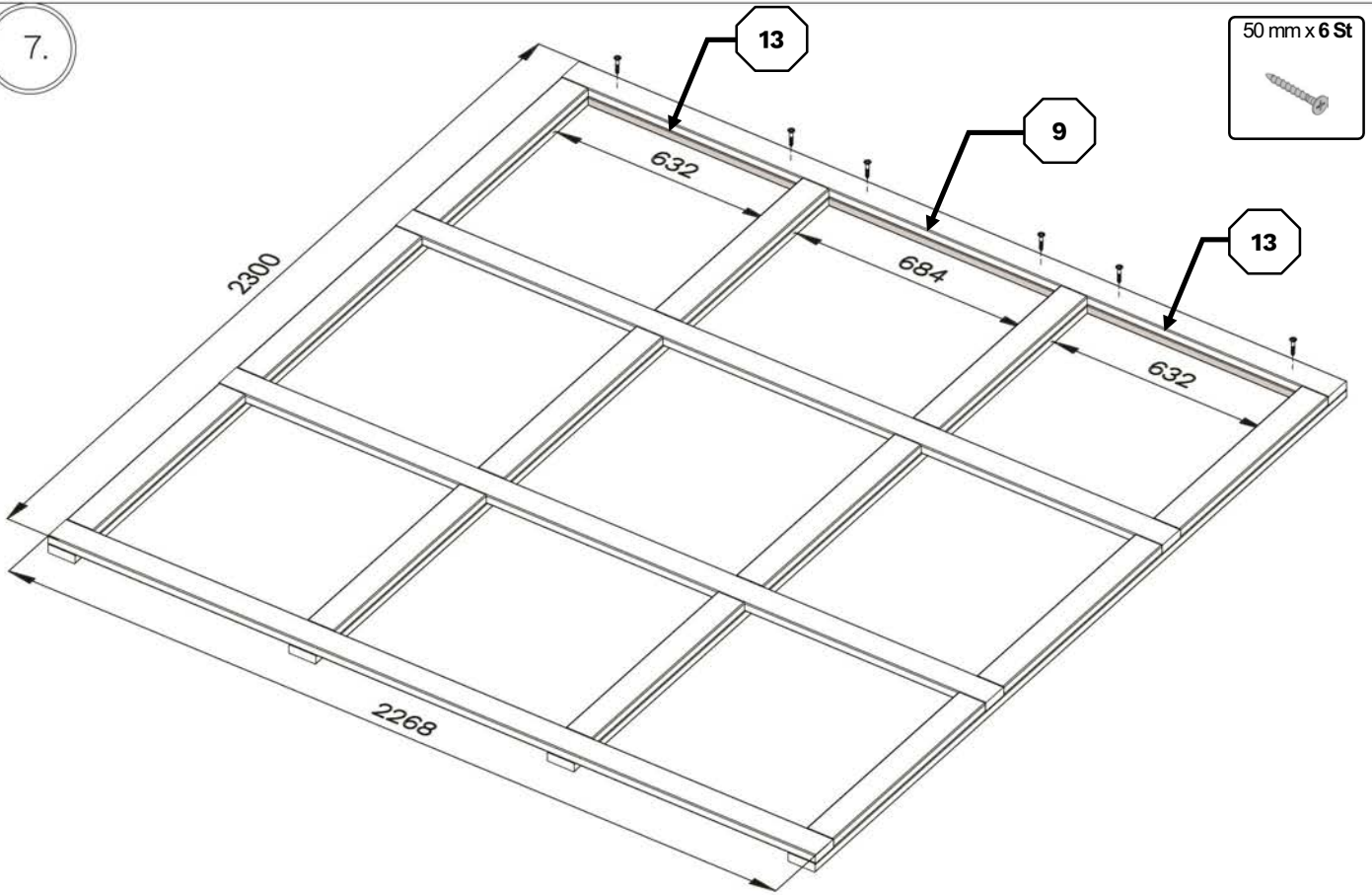

8.

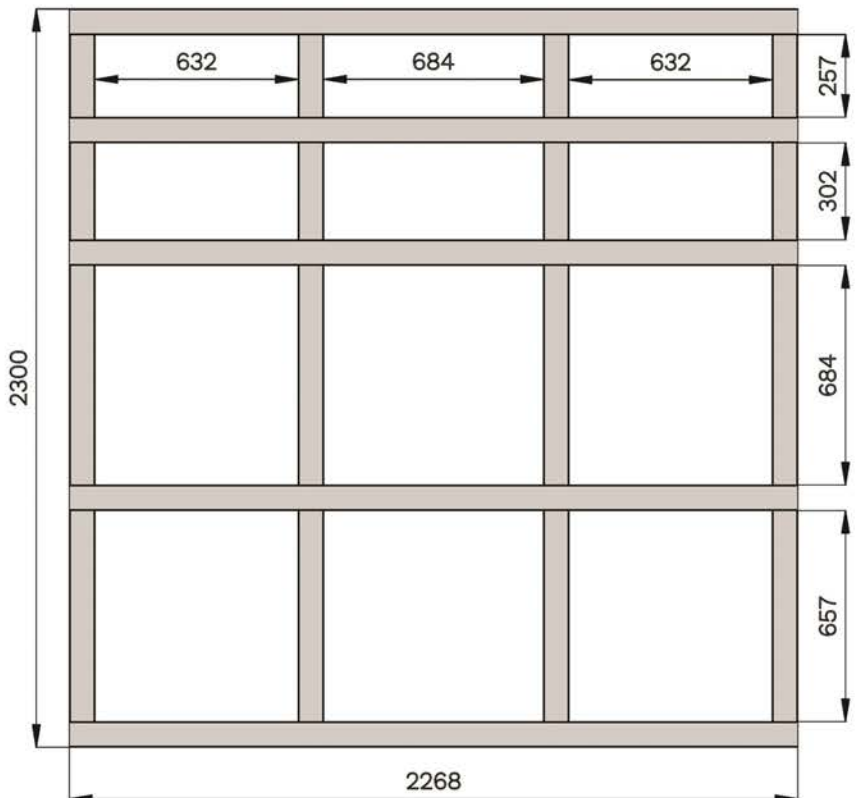
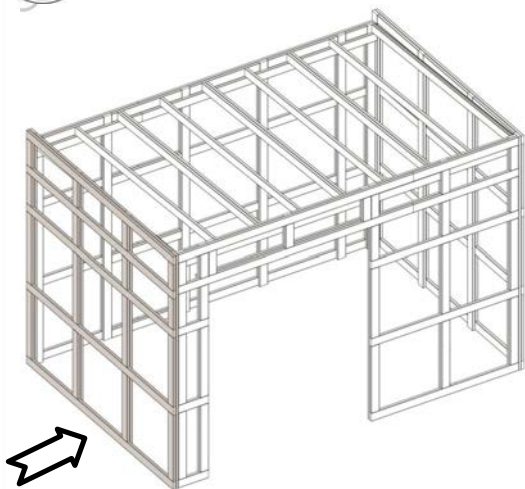

Holzschutzmittel / Wood preservative

HPL 2

9.

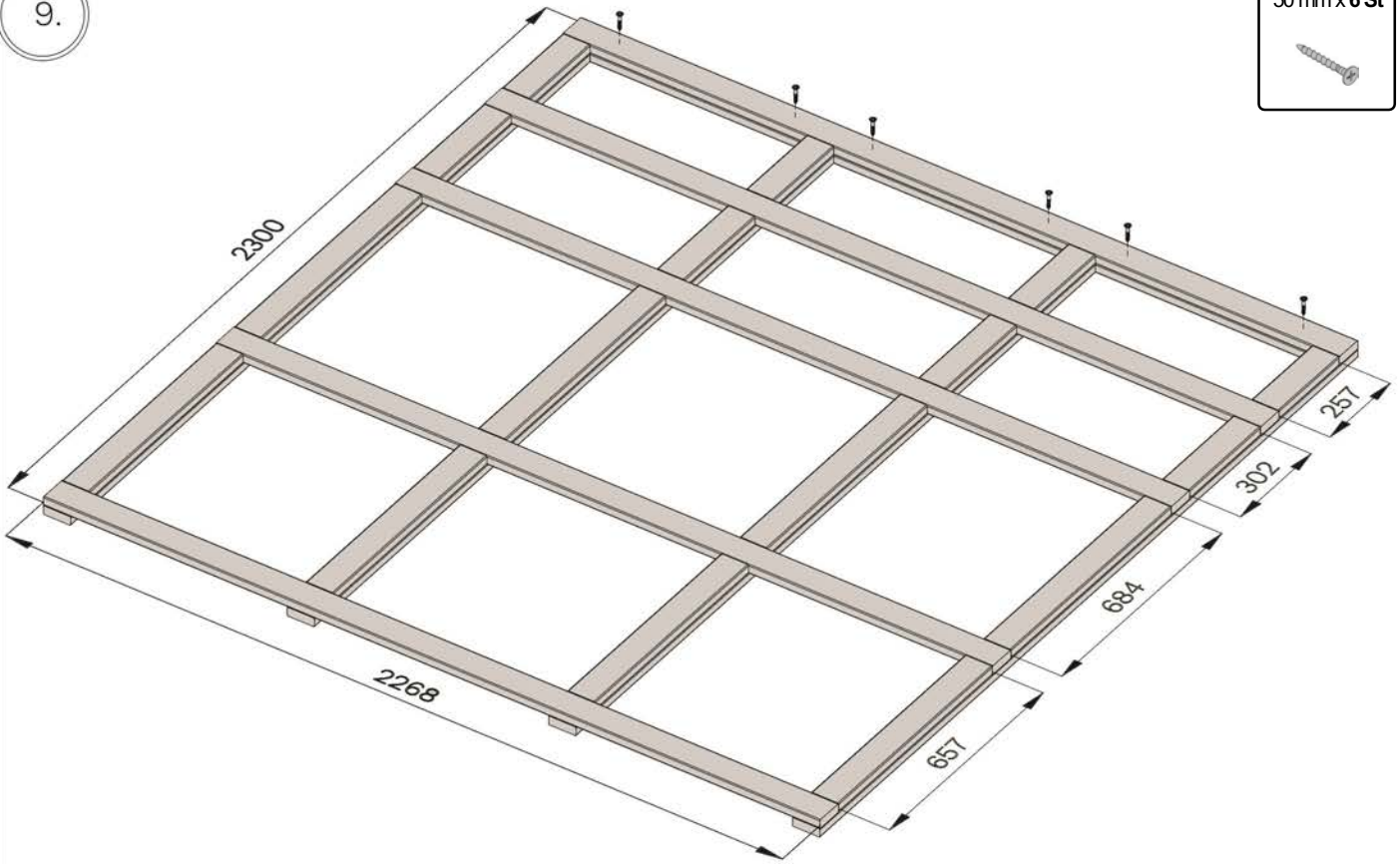

50 mm x 6 St



10.

A=B

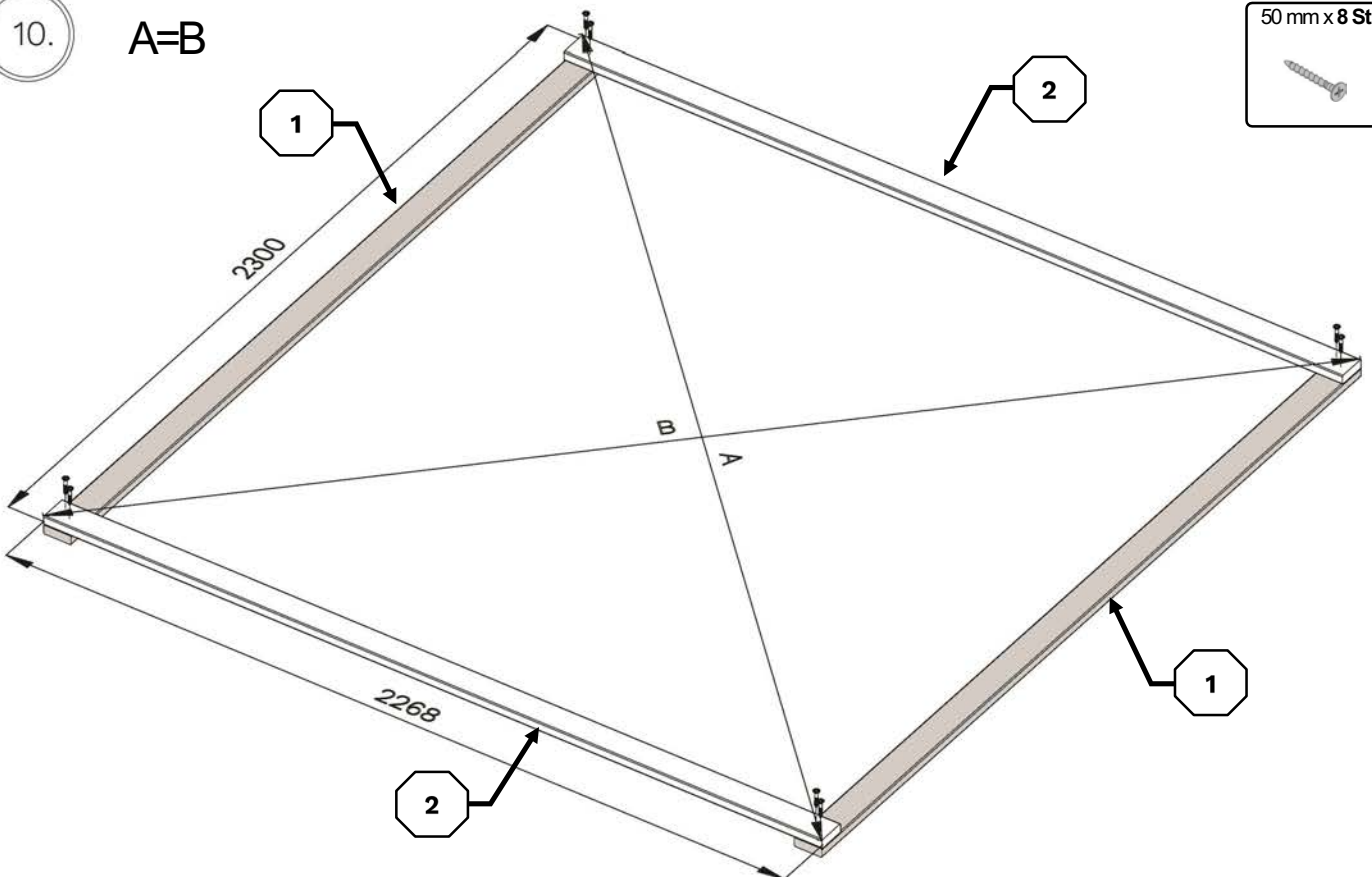

50 mm x 8 St



HPL 2

11.

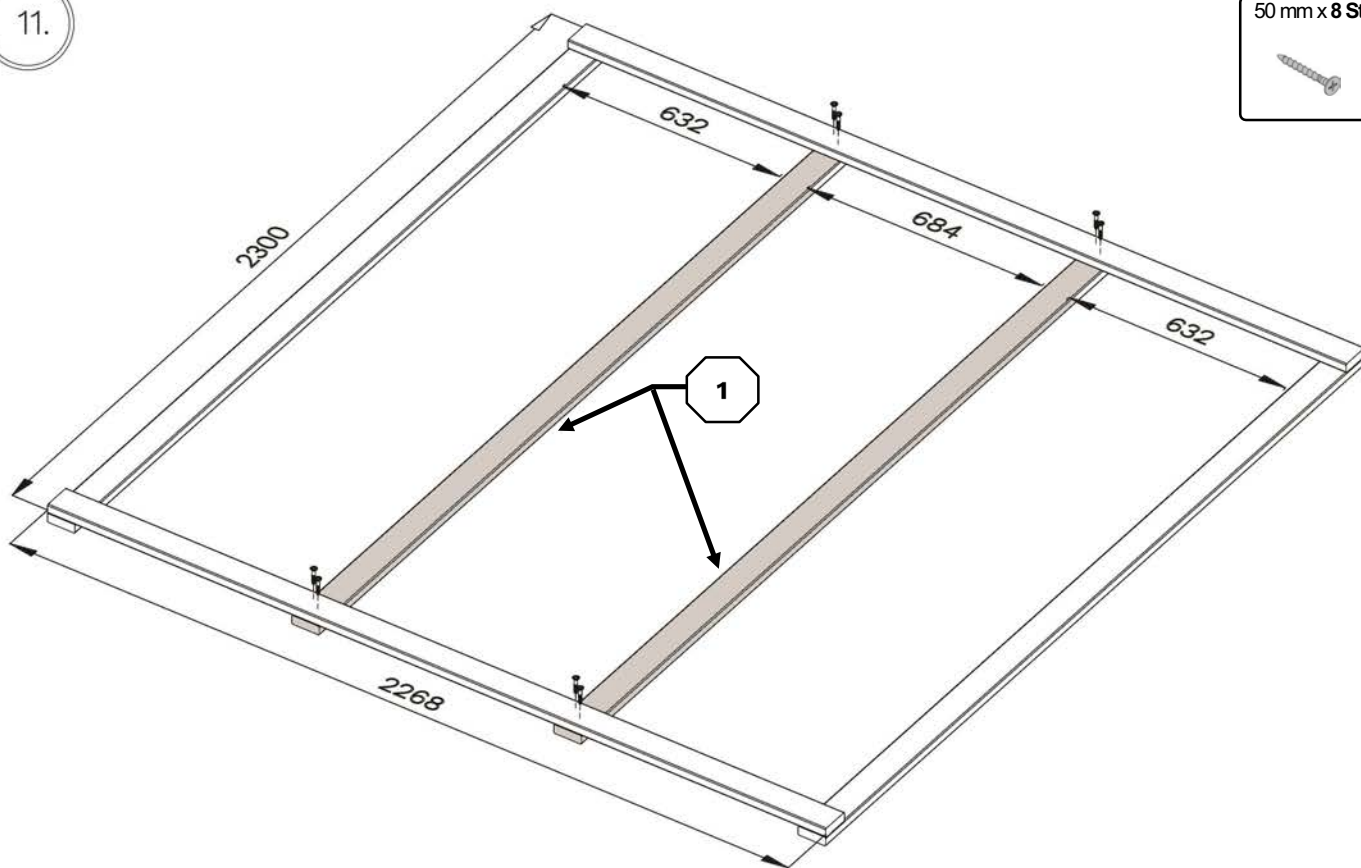

50 mm x 8 St



12.

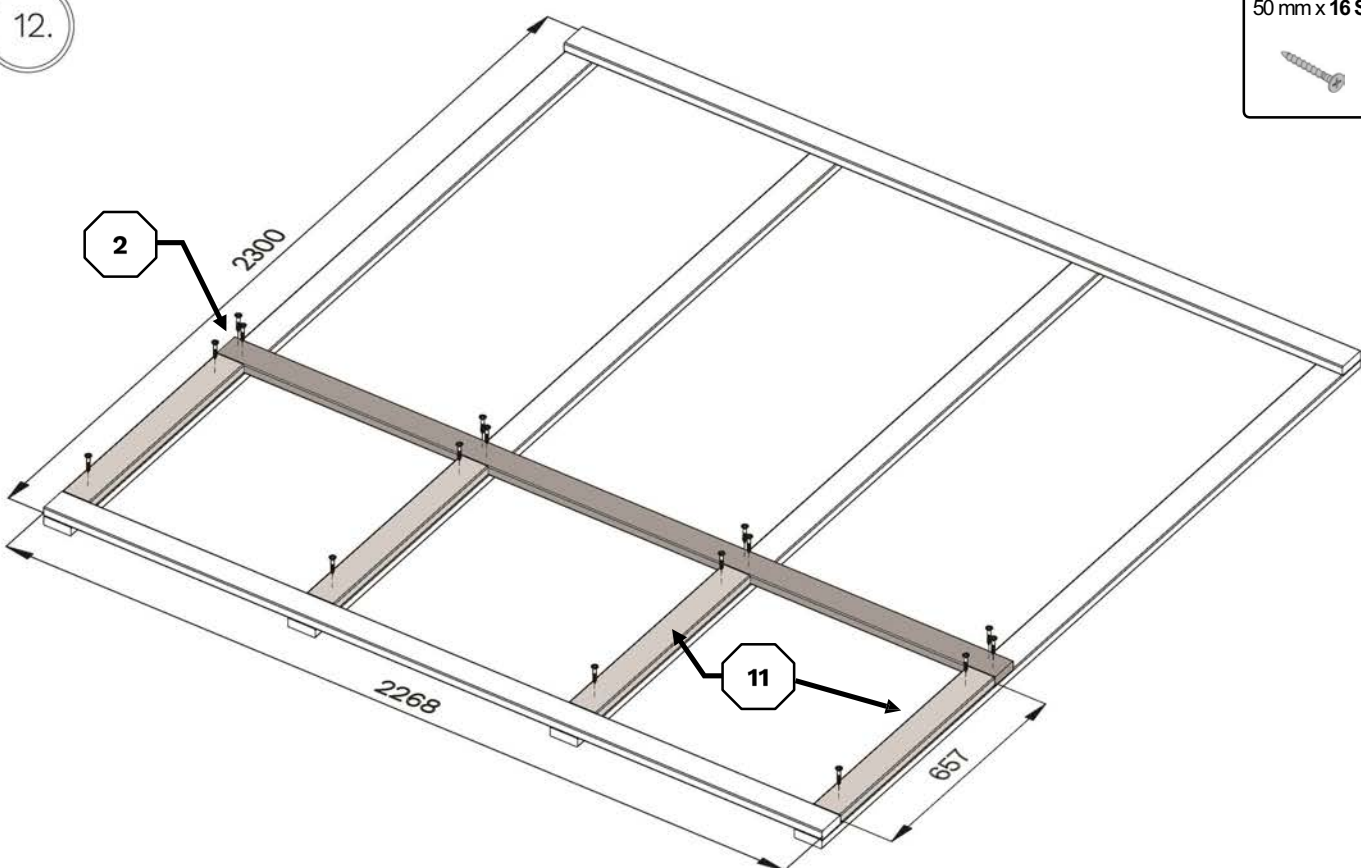

50 mm x 16 St



HPL 2

13.

50 mm x 16 St

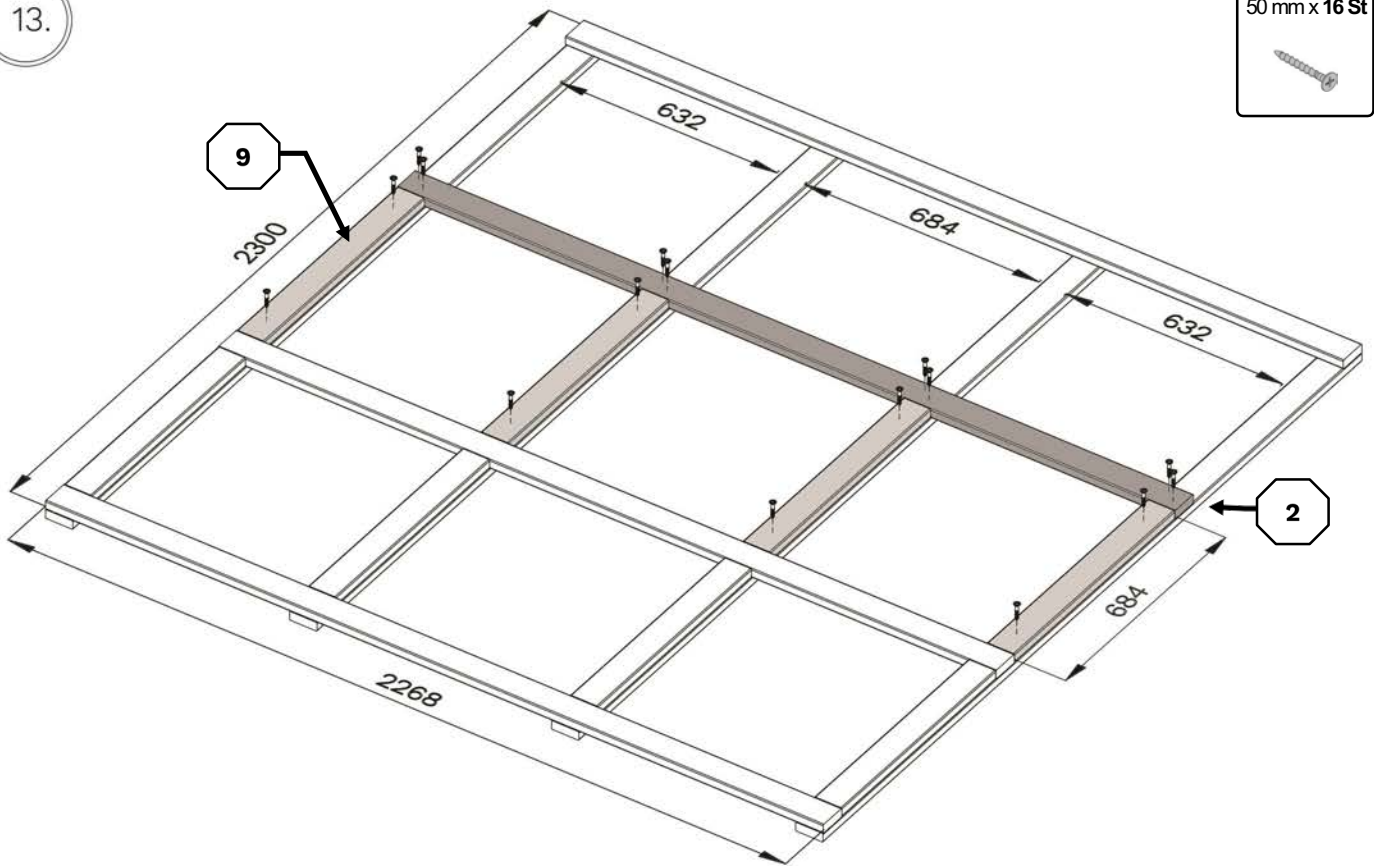

14.

50 mm x 24 St

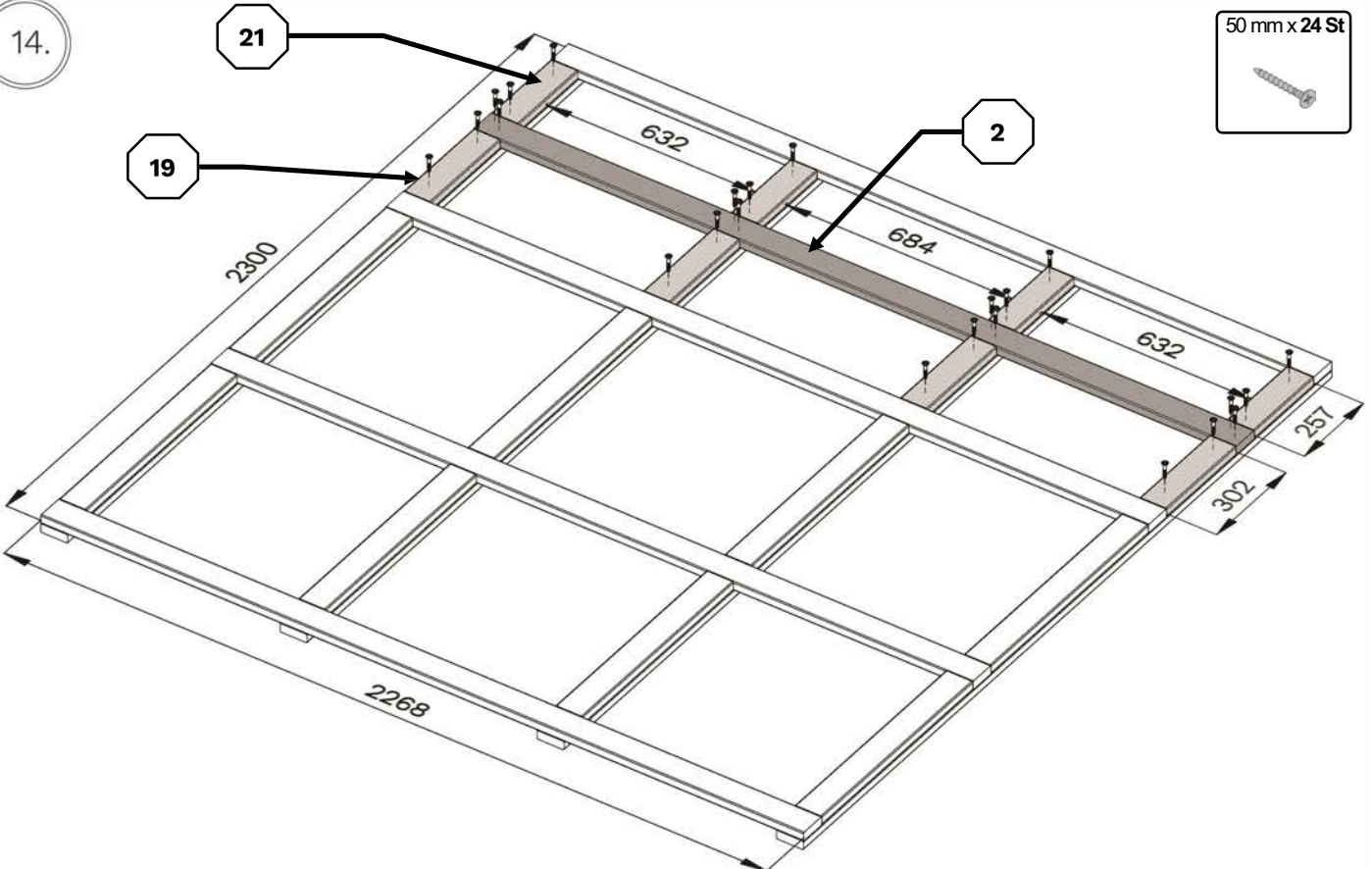

HPL 2

15.

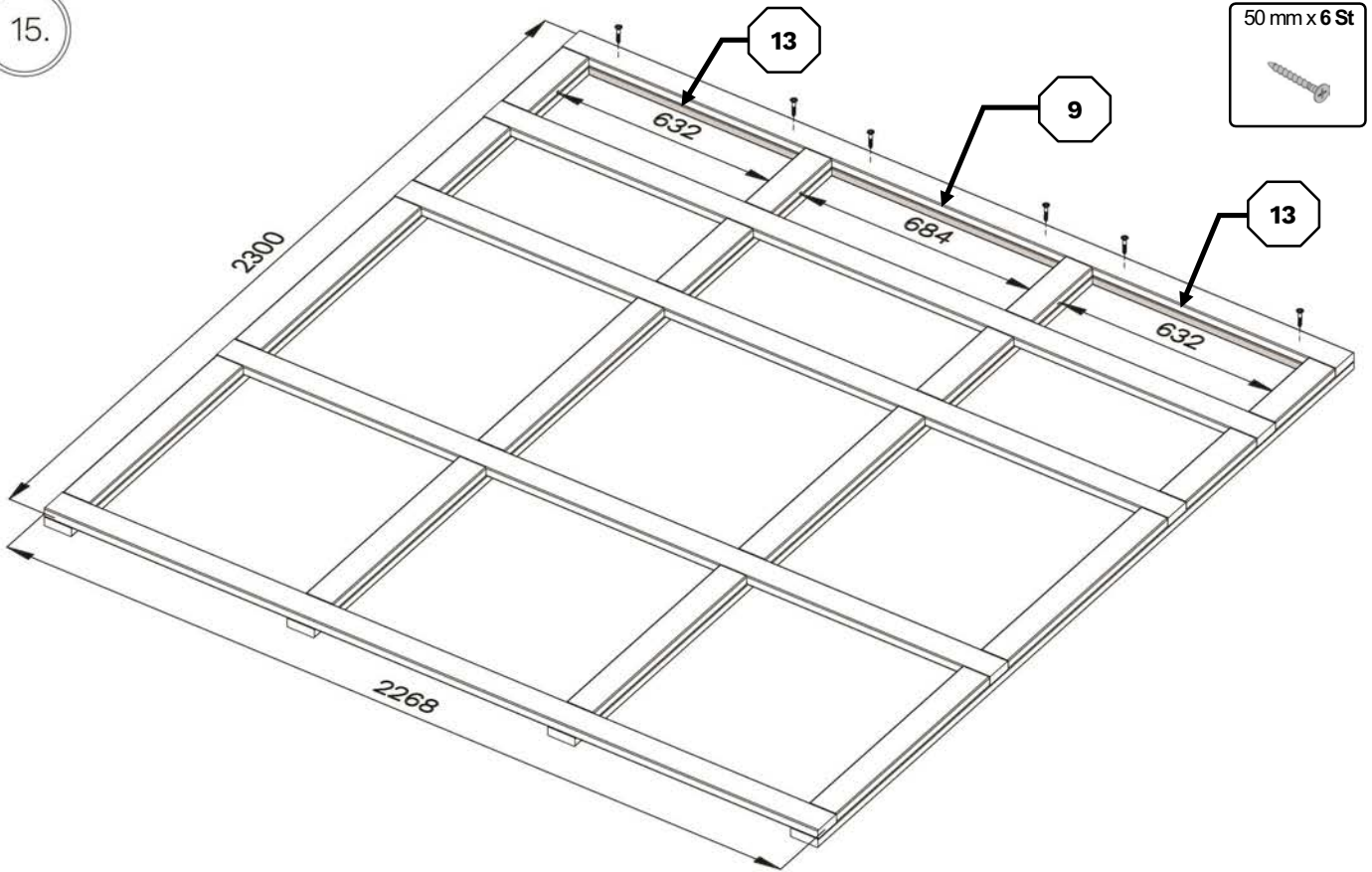

16.

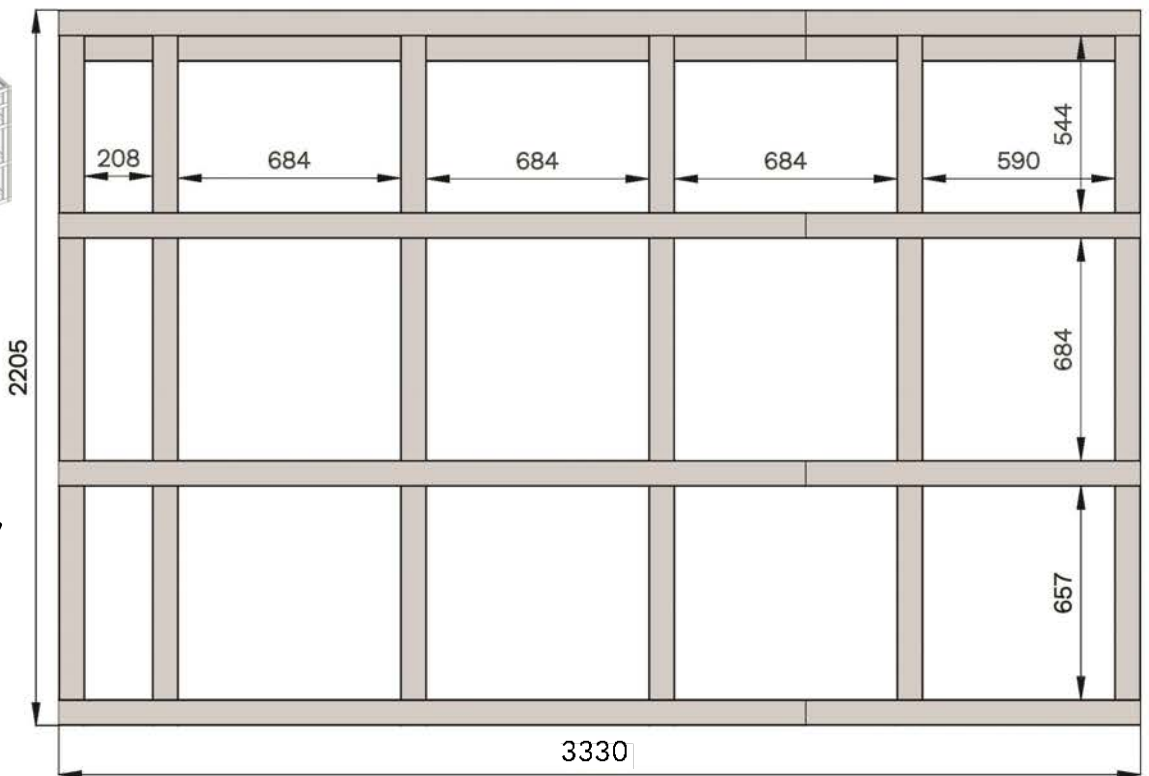
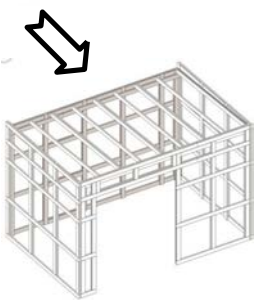

Holzschutzmittel /
Wood preservative

HPL 2

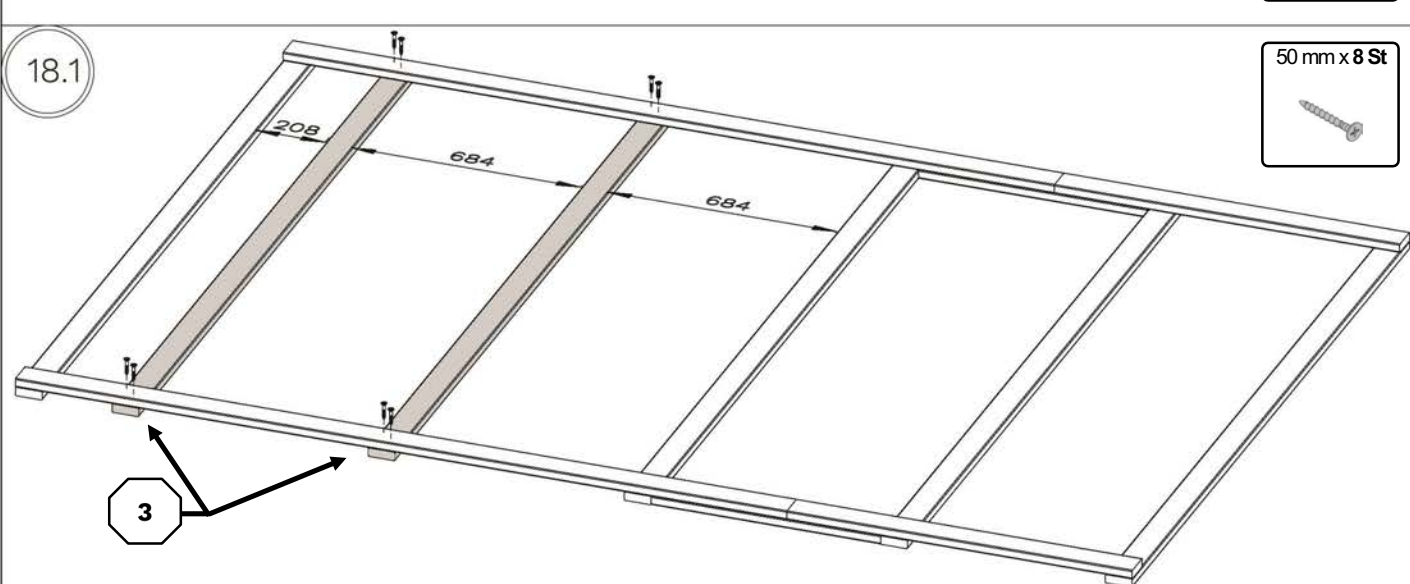
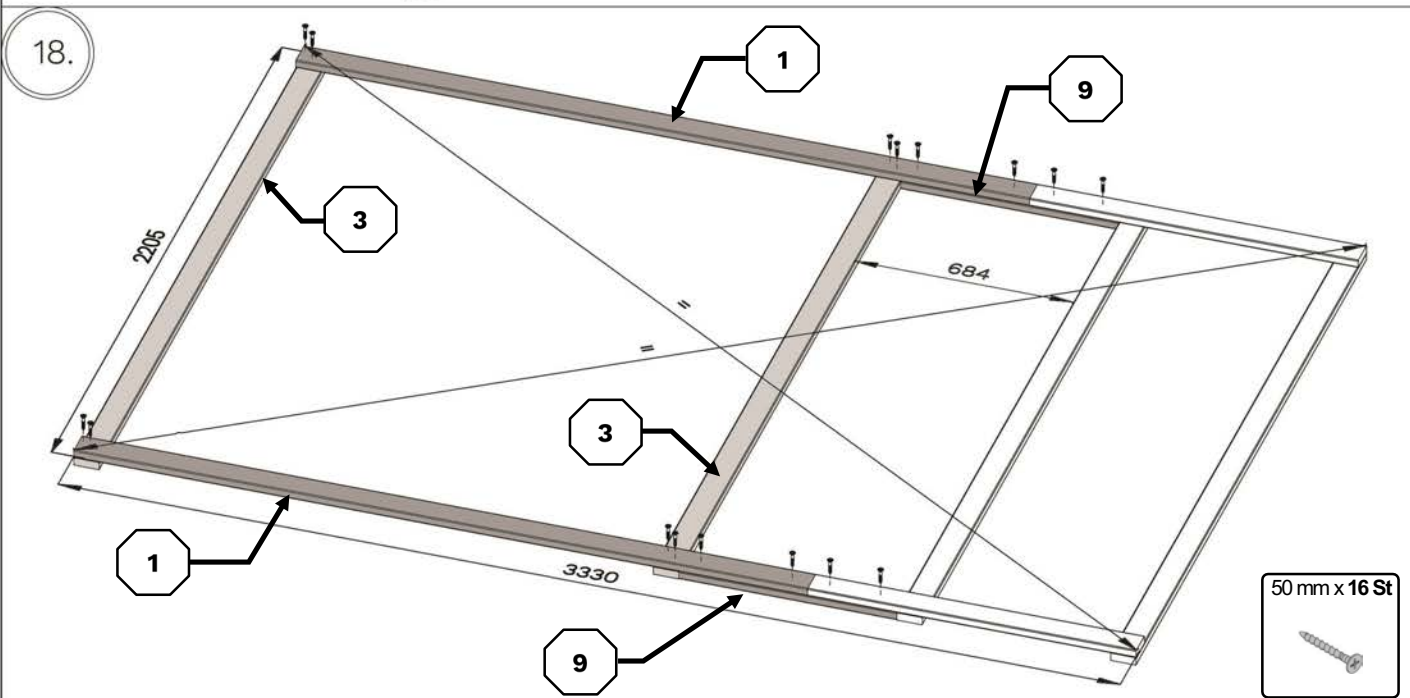
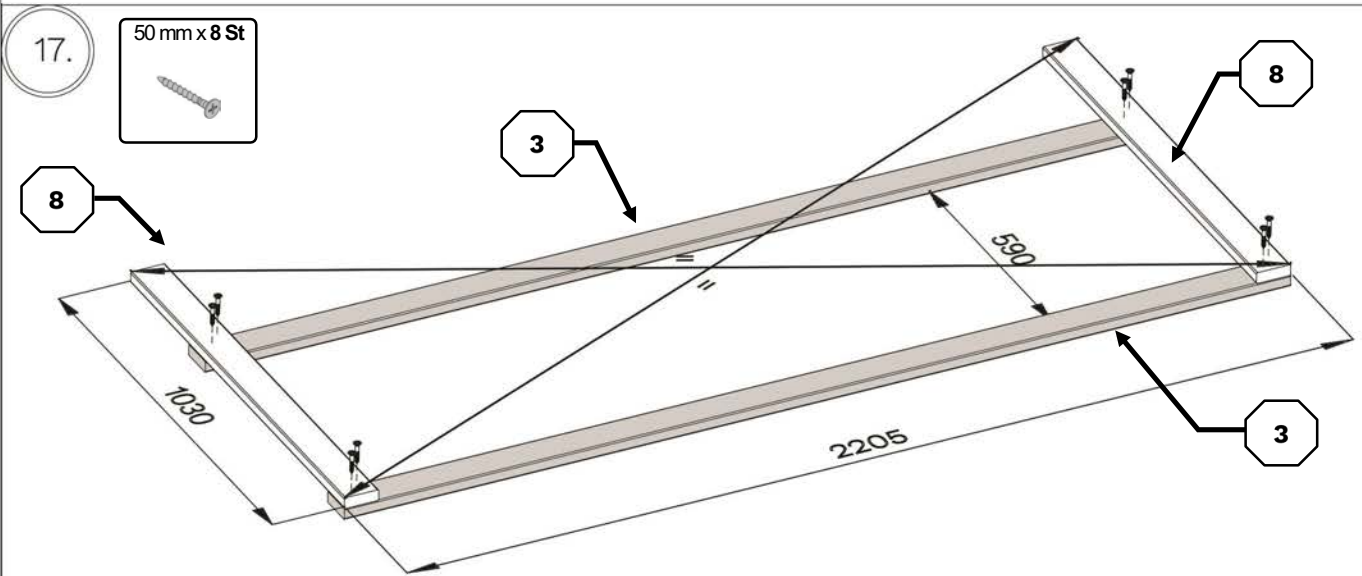

HPL 2

19.

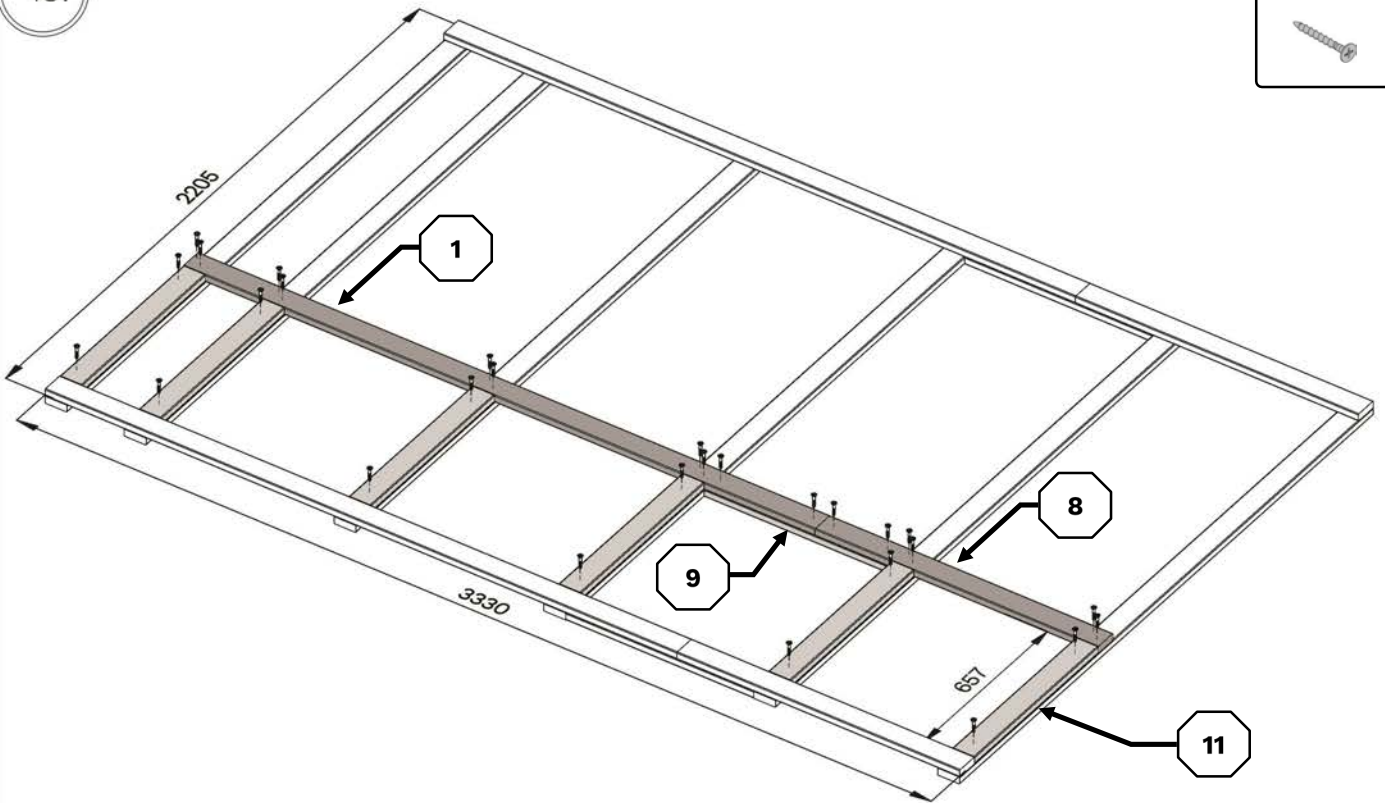
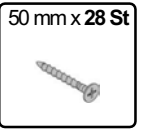

20.

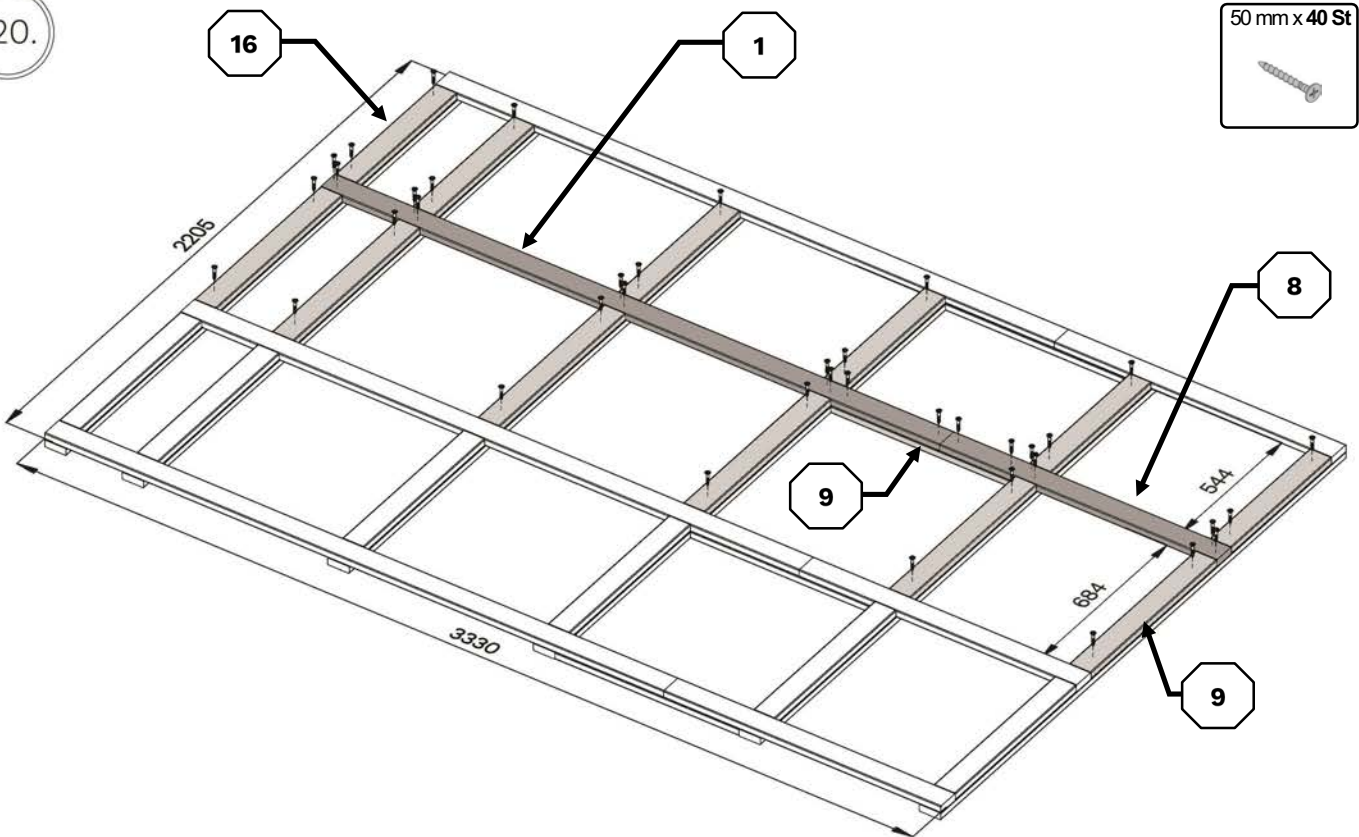

HPL 2

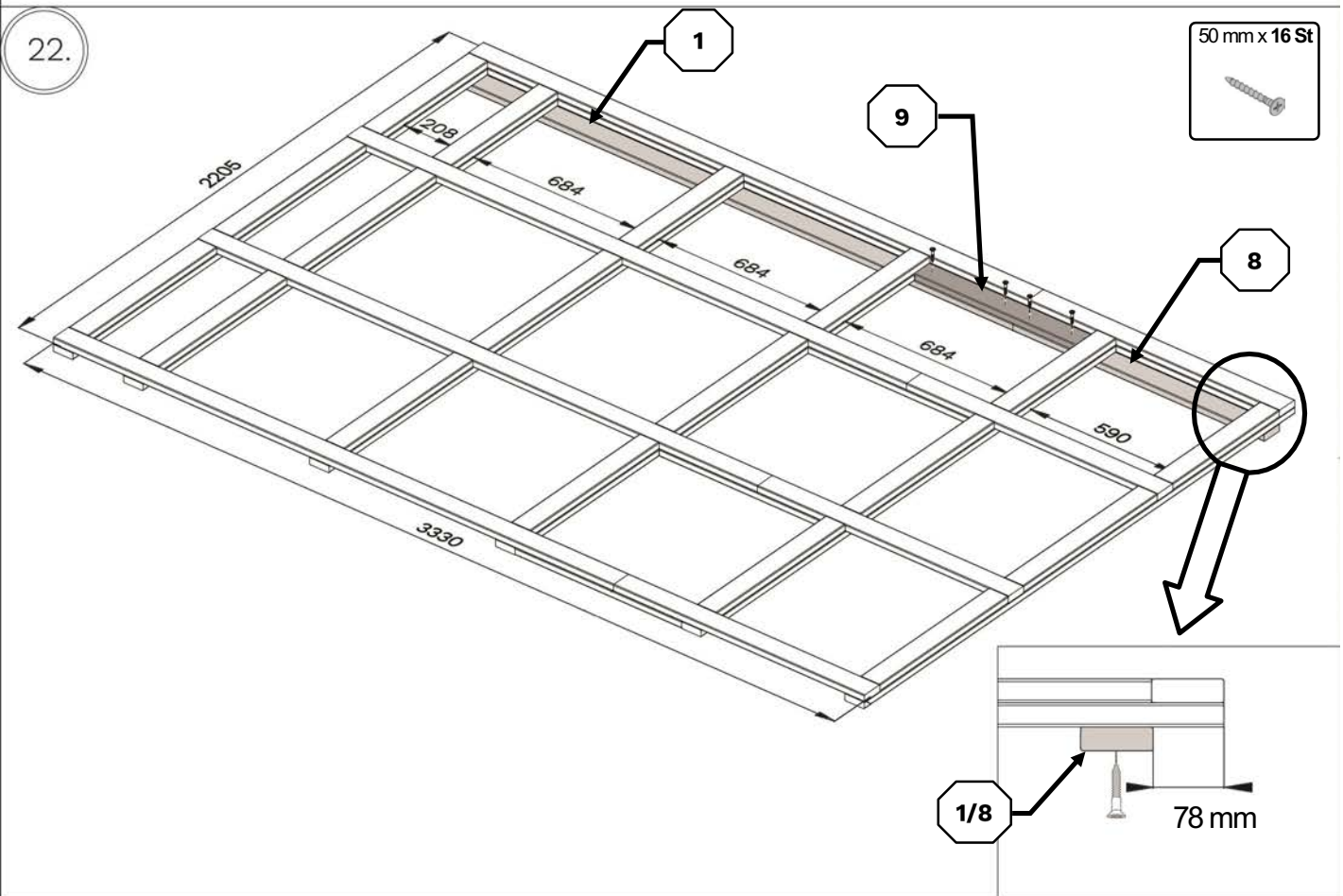
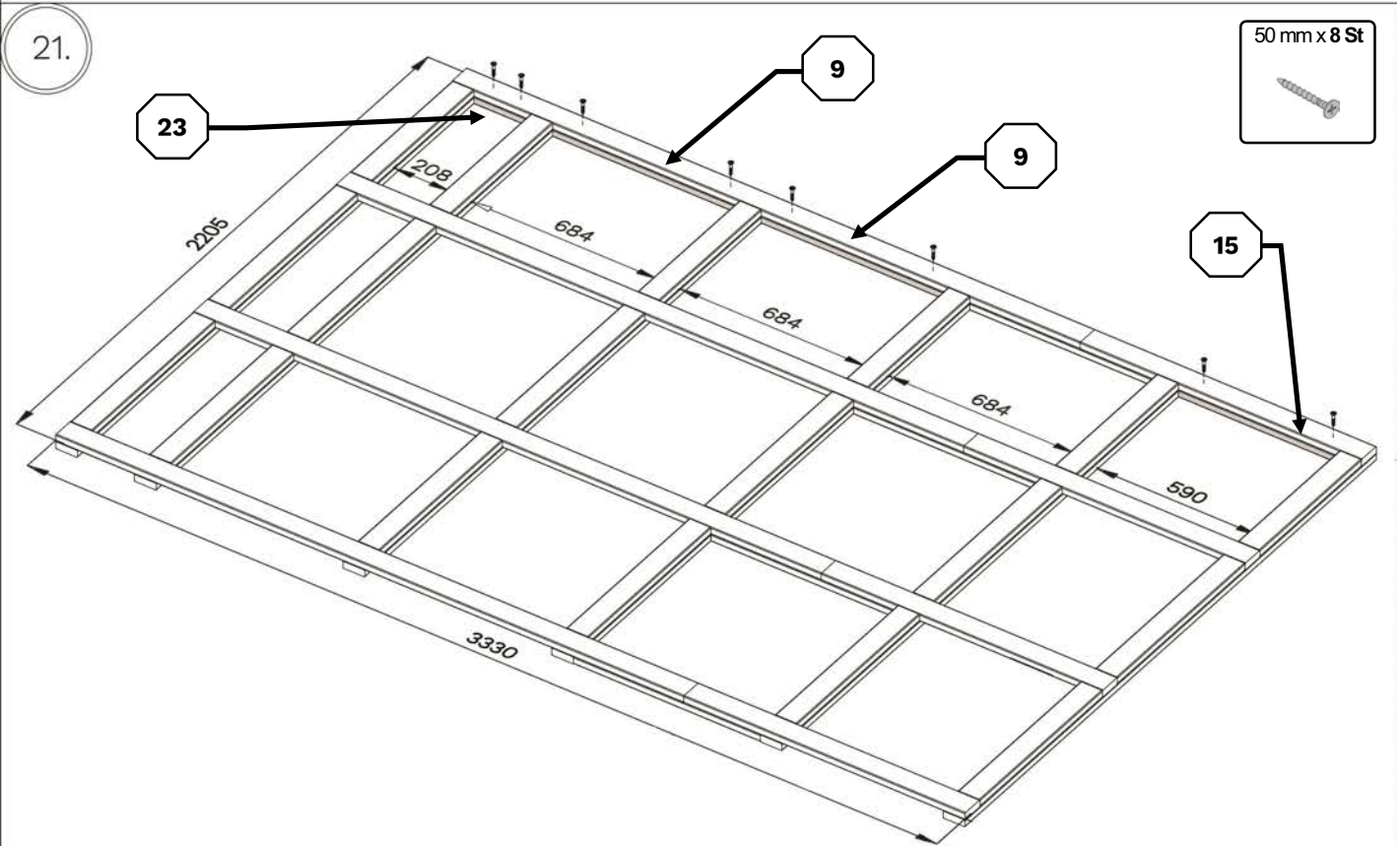

HPL 2

23.

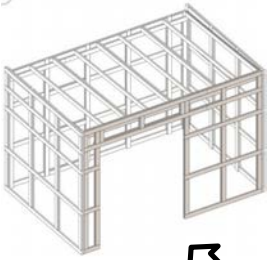

Holzschutzmittel /
Wood preservative

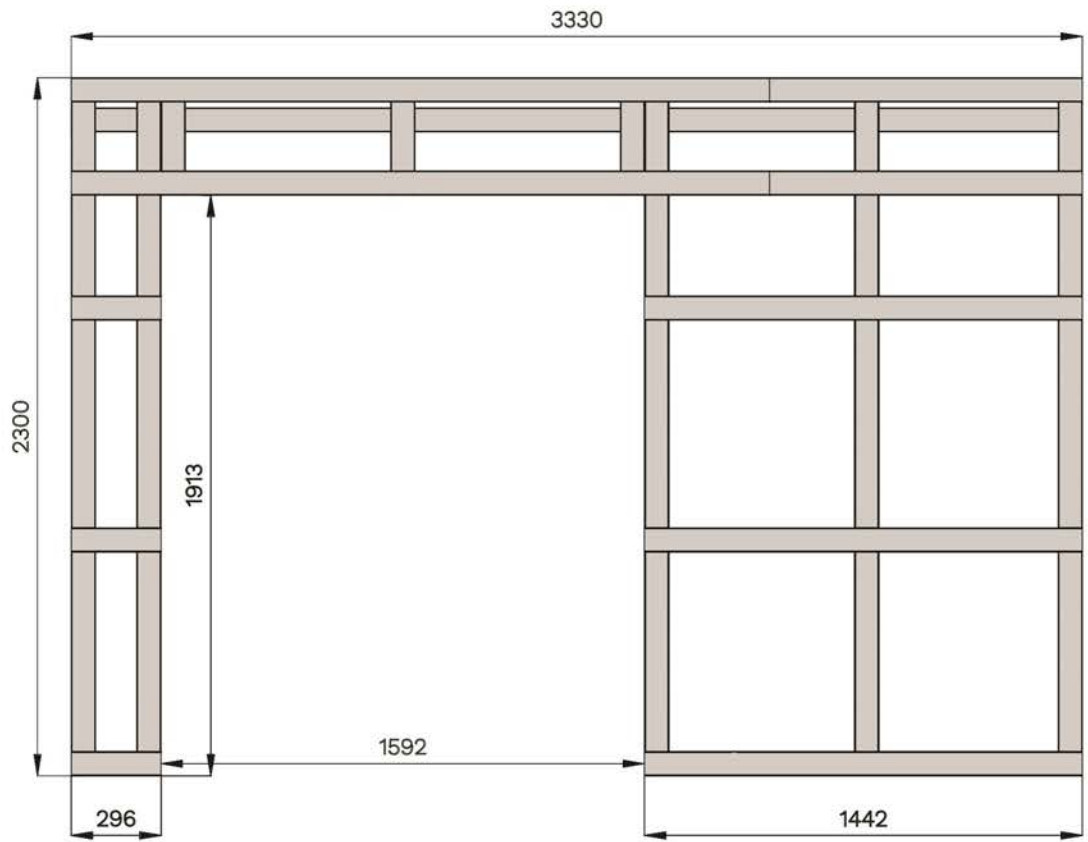

24.

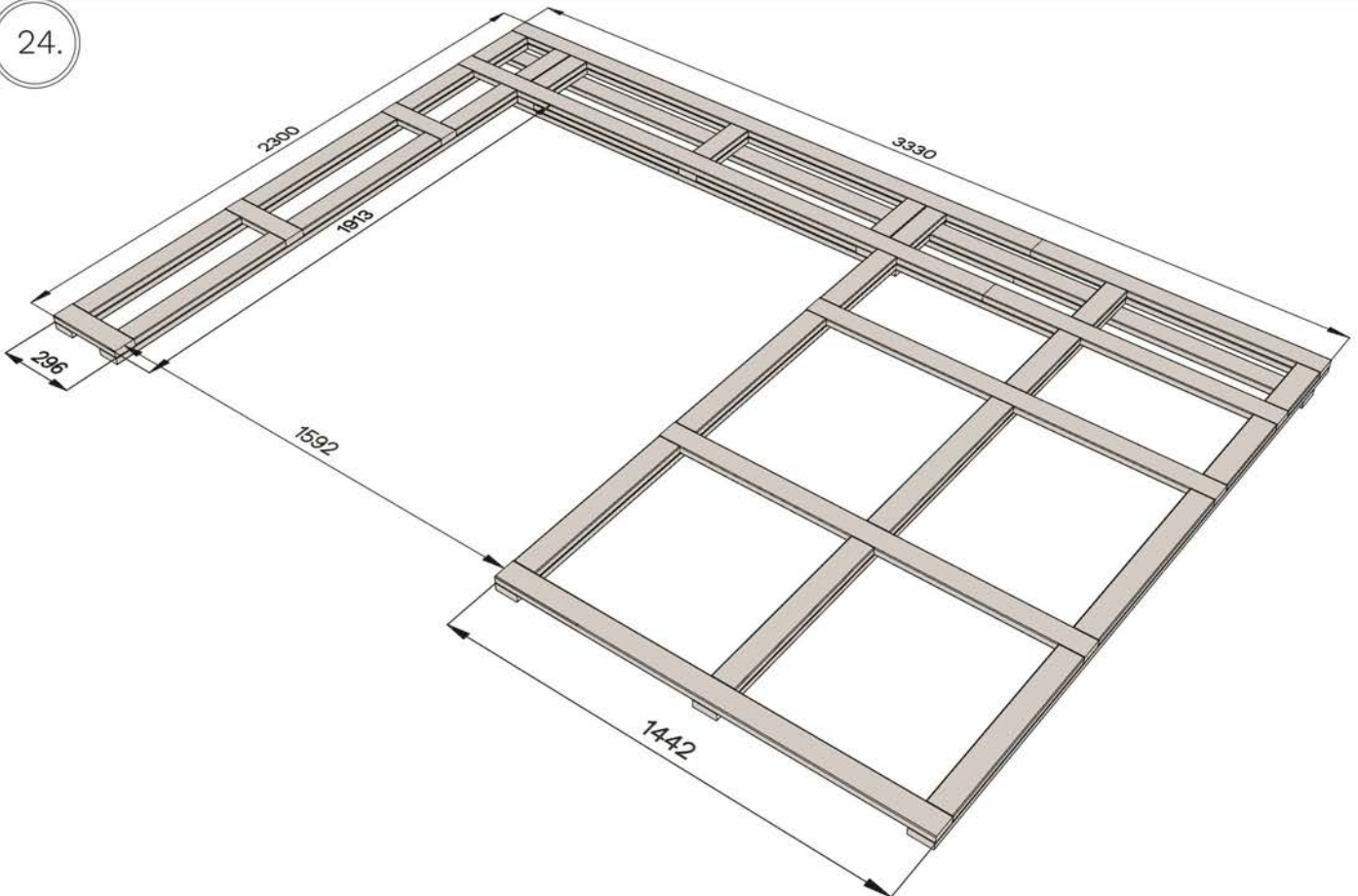

HPL 2

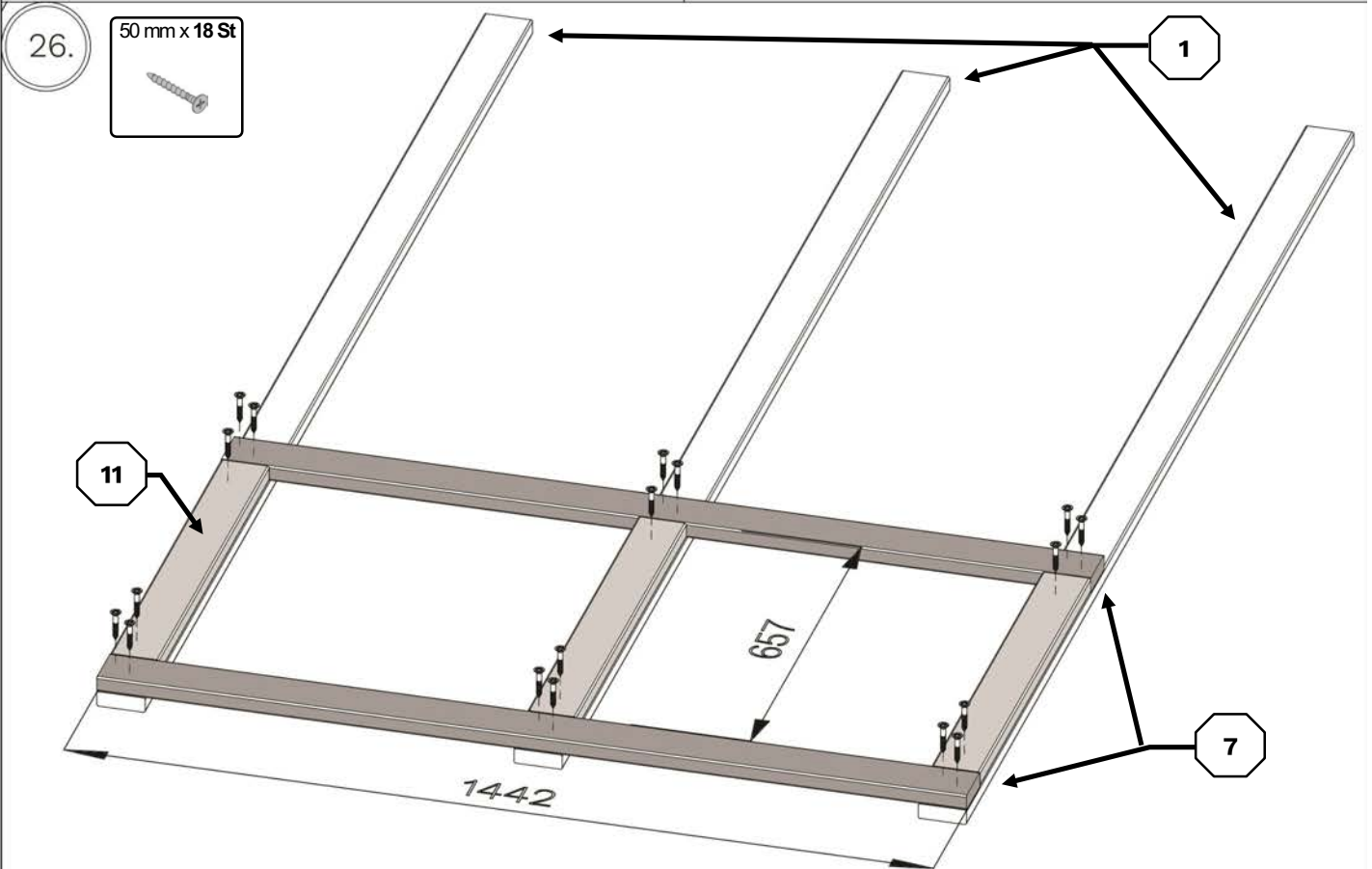
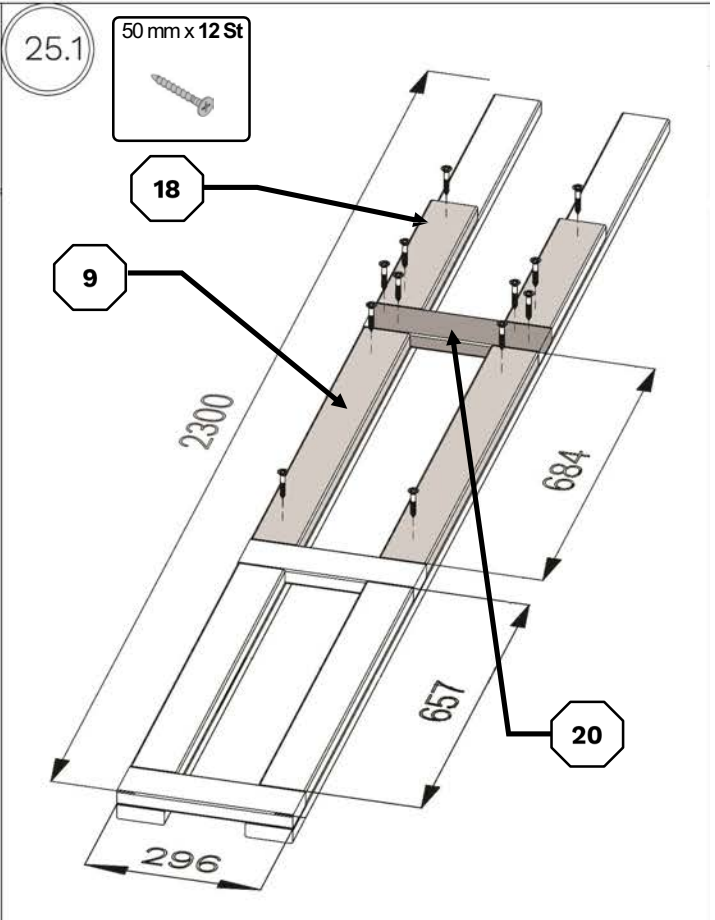
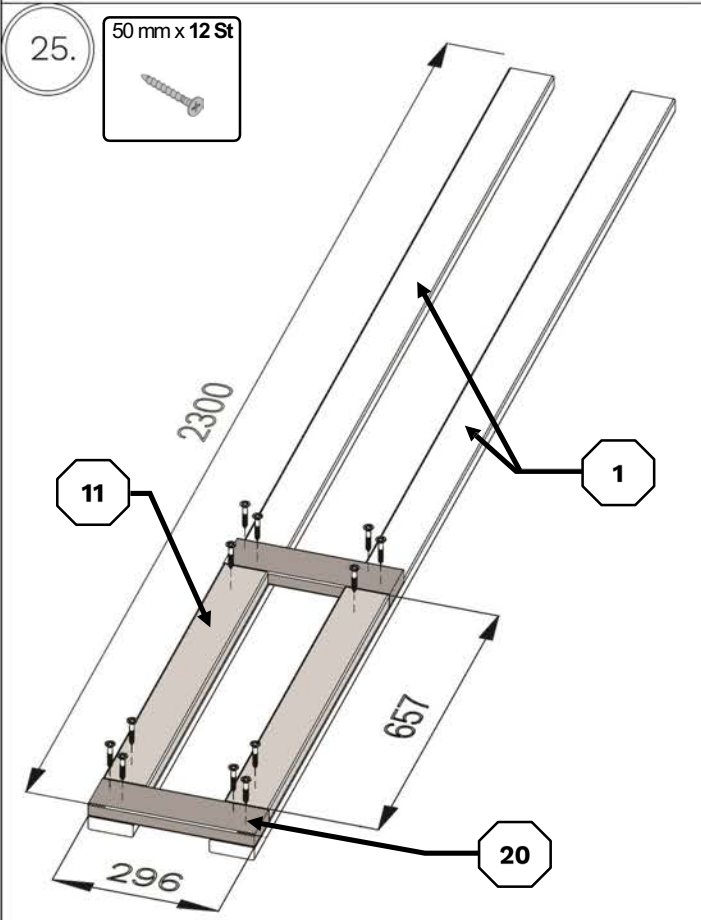

HPL 2

26.1

50 mm x 18 St

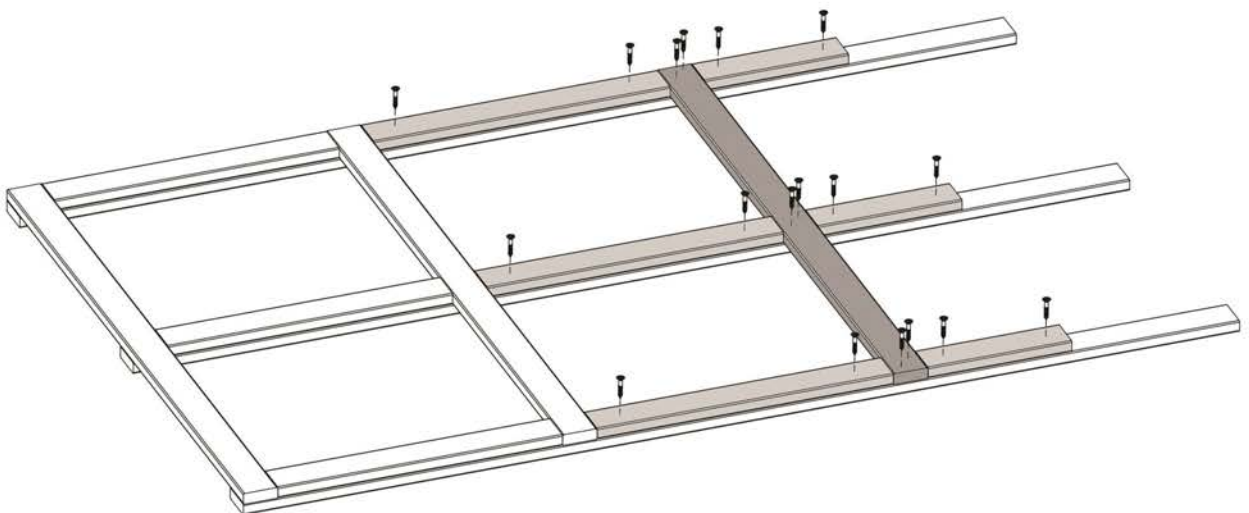
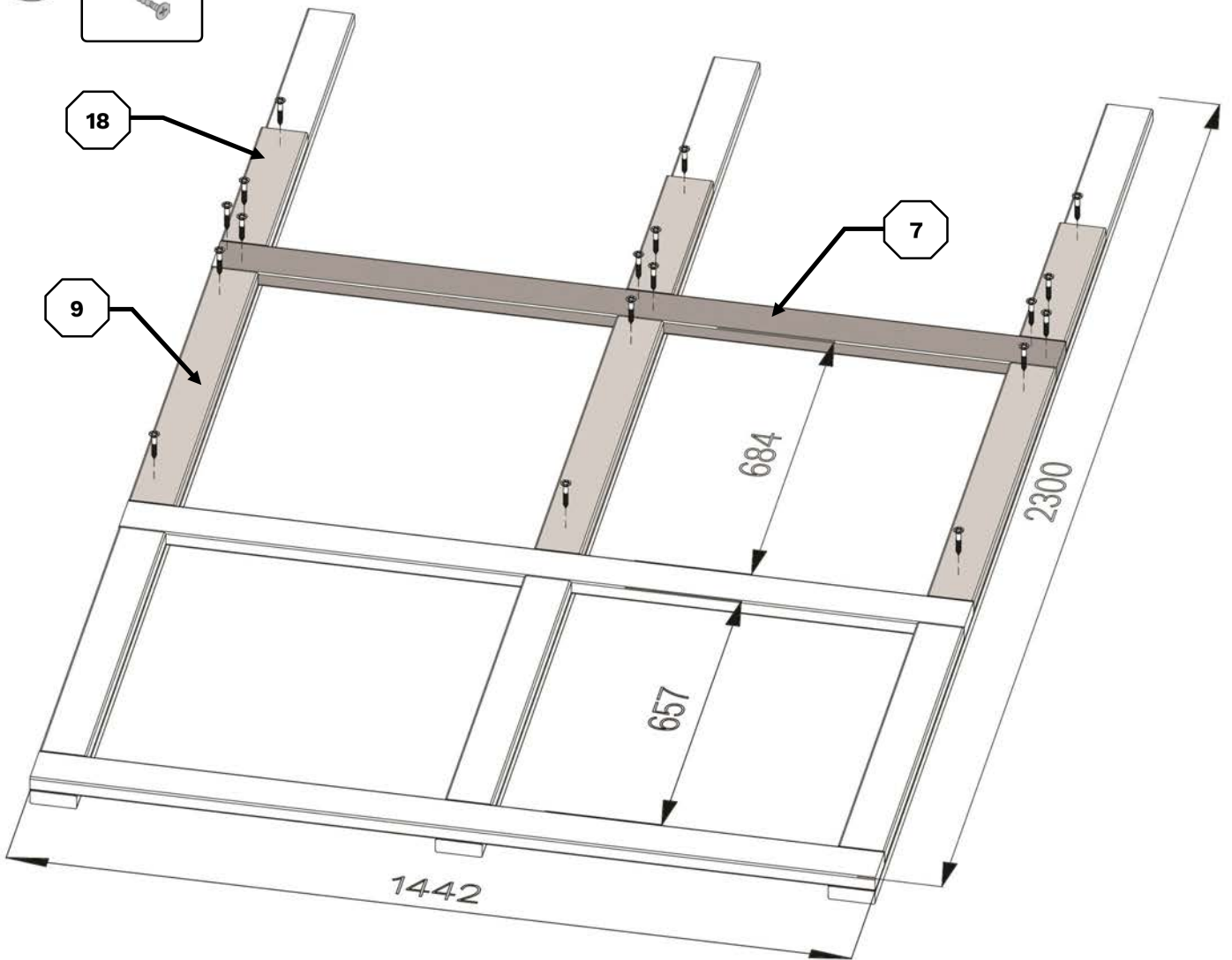

HPL 2

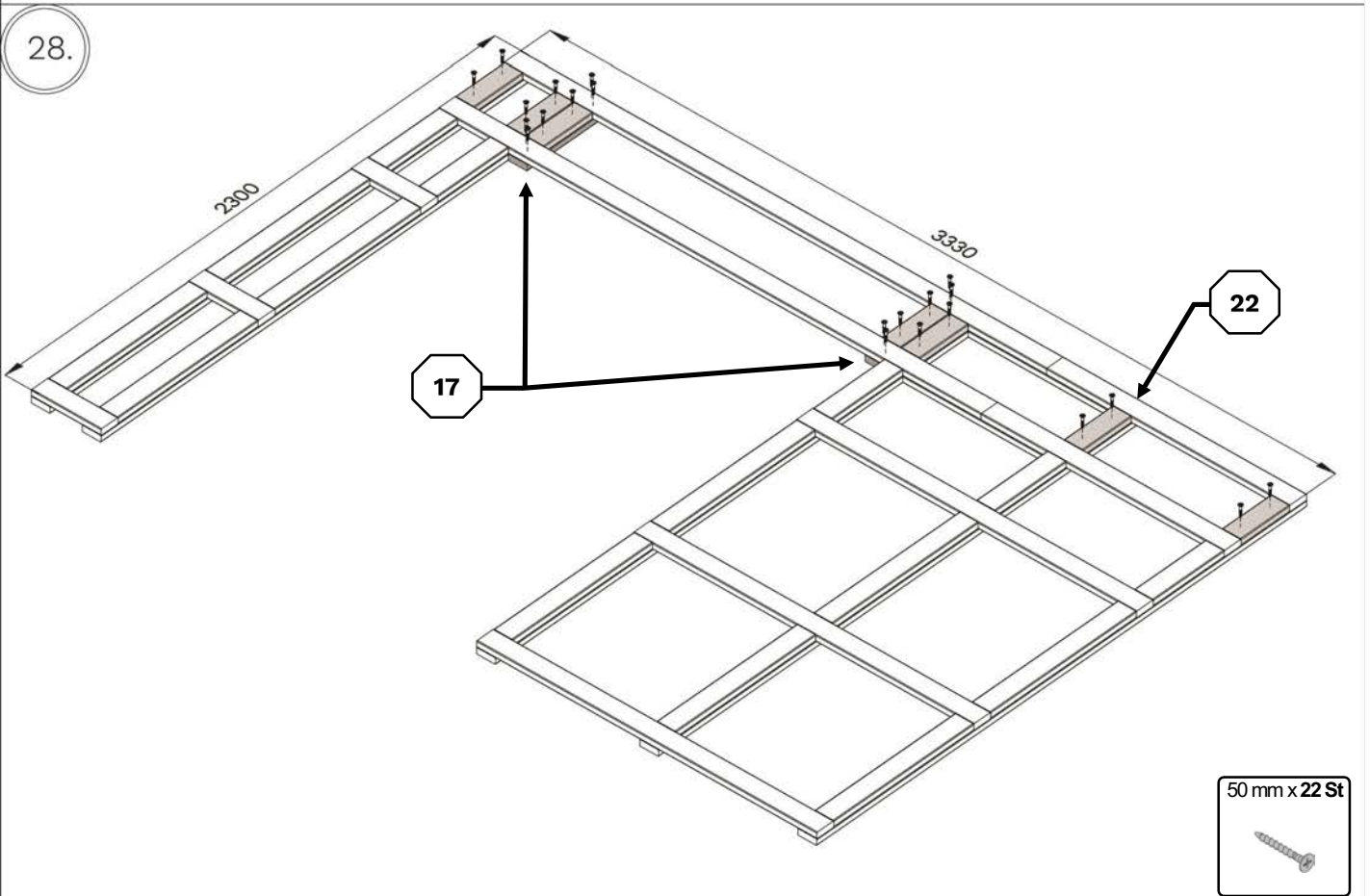
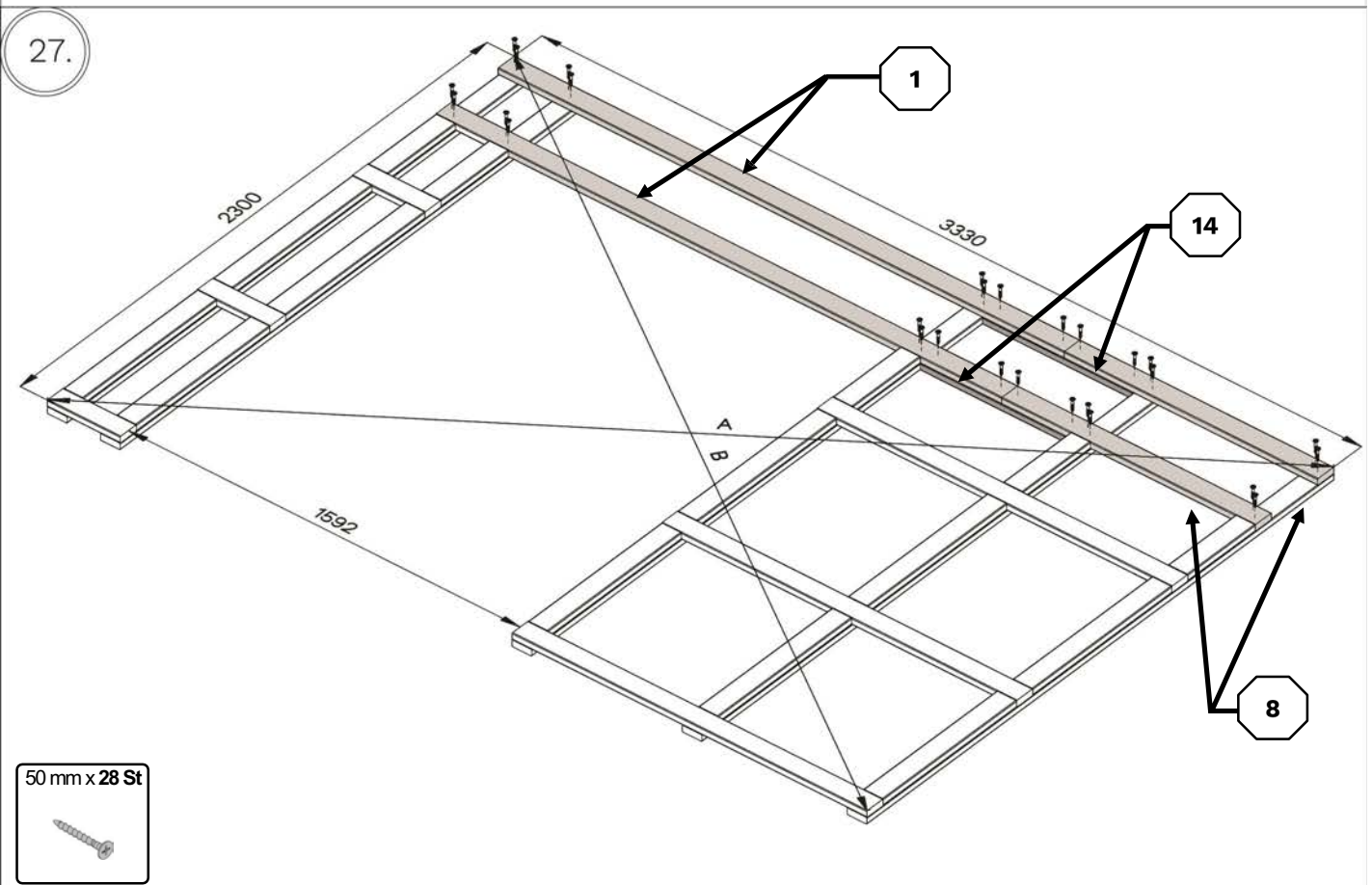

HPL 2

29.

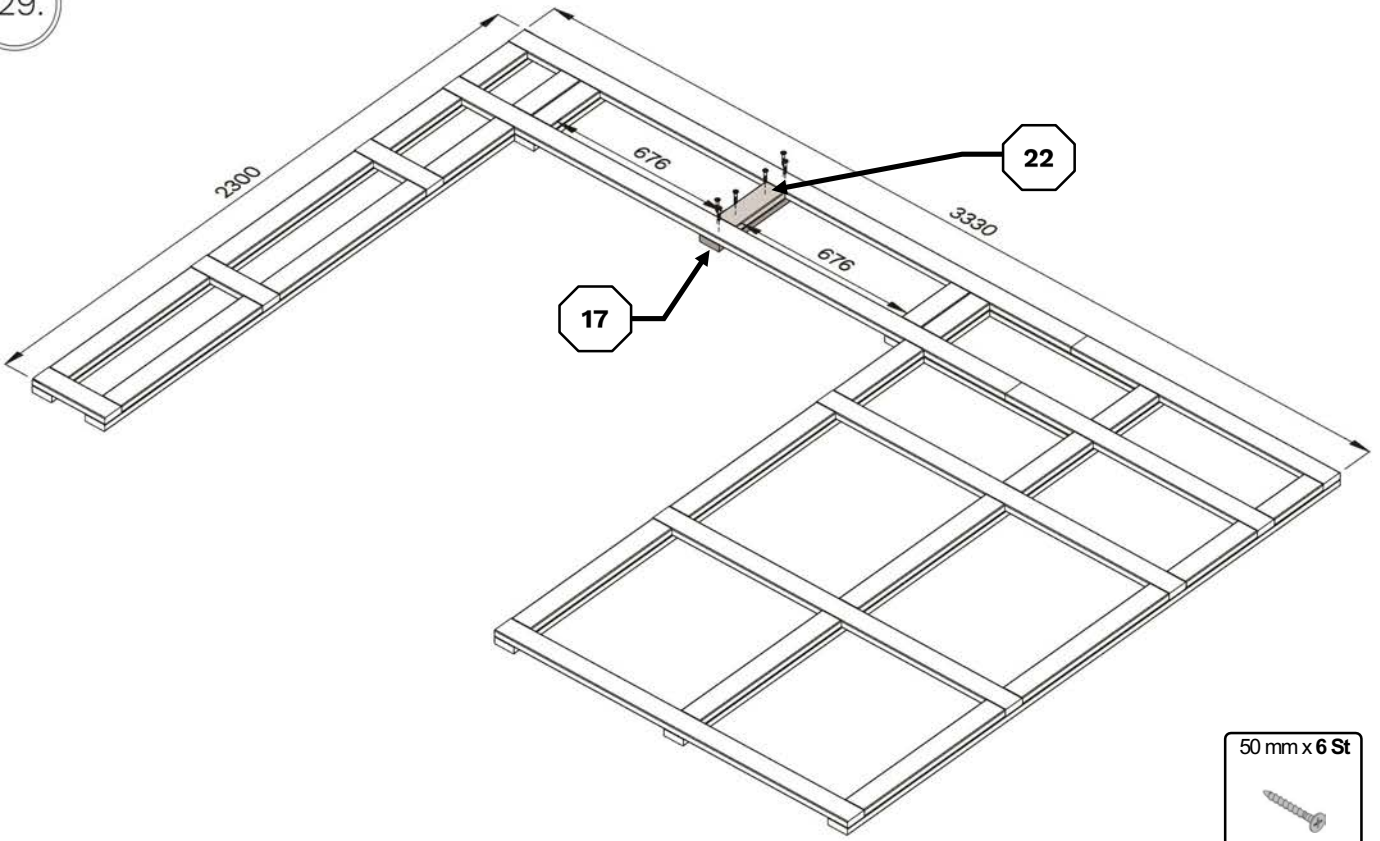

30.

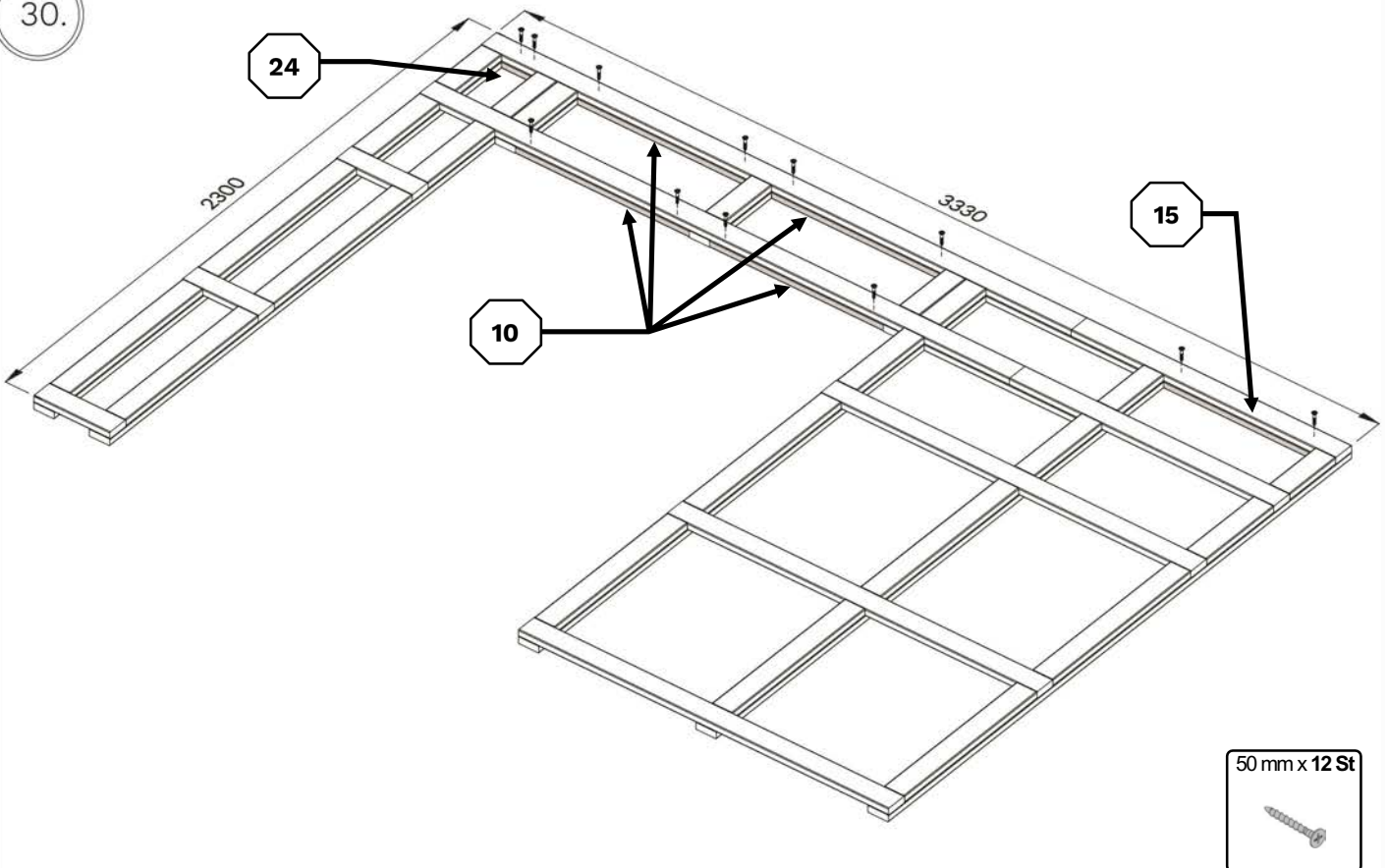

HPL 2

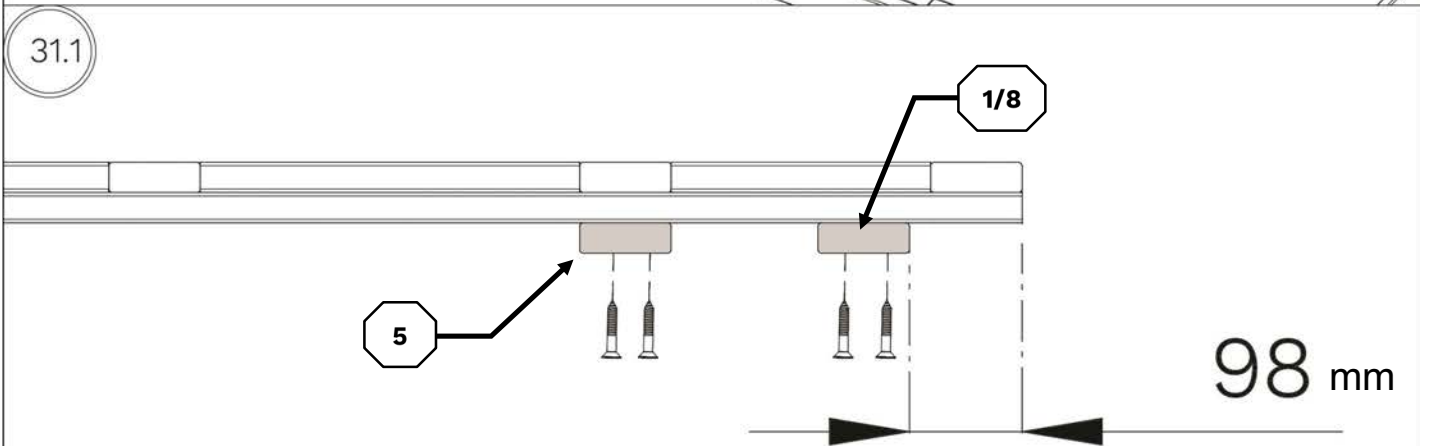
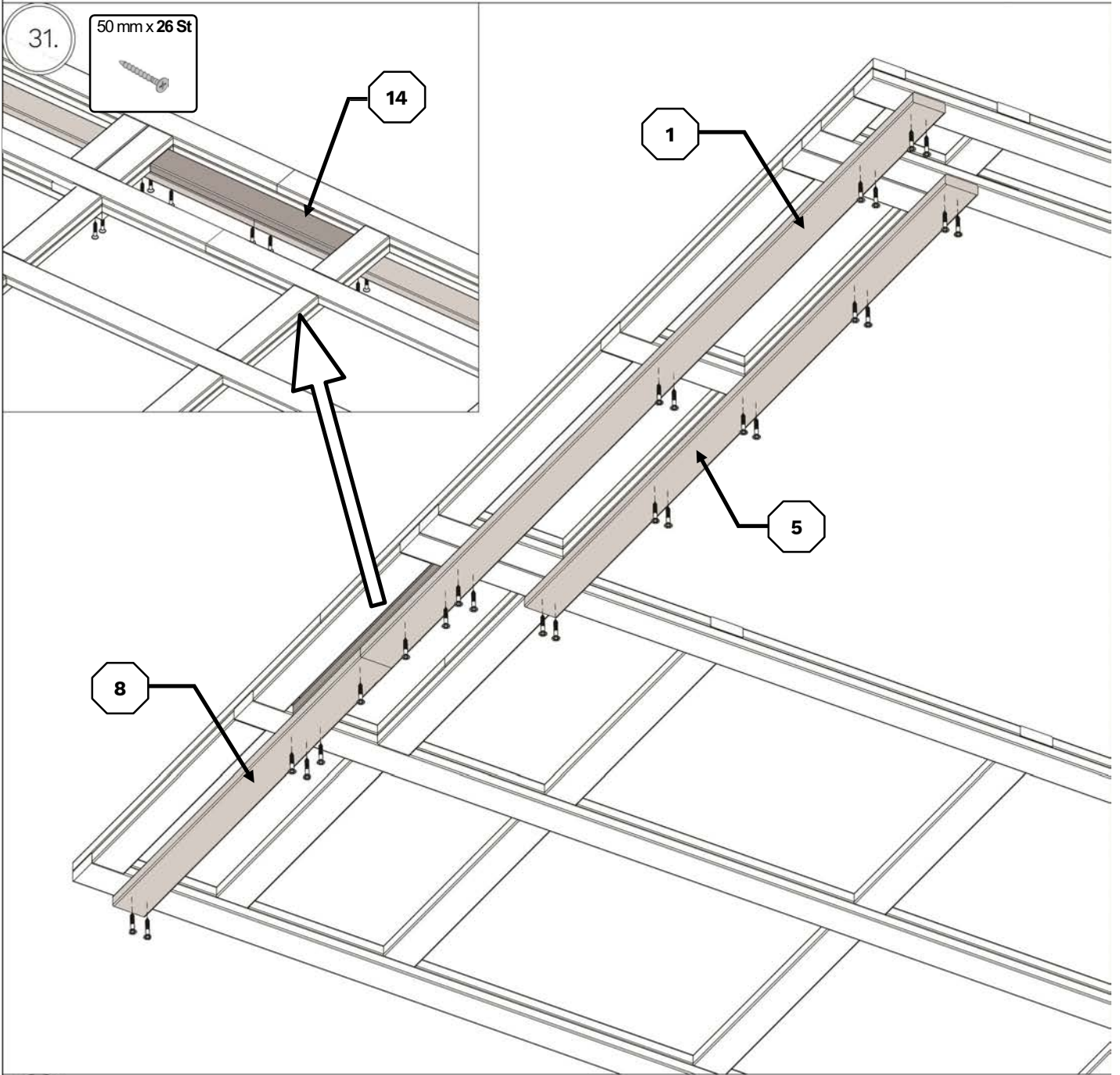

NB! ^{L2} Empfohlen bei Aufbau auf besonders feuchtem Untergrund. (**Nicht im Lieferumfang enthalten!**)
 Recommended for assembly on moist ground. (**Not included!**)

* Unterlegpads /
 * Patio Pads

Min. 9100 lfm/rmm



+€

* Imprägniert Kantholz /
 * Impregnated beam

~40*60*9100 lfm/rmm



+€

* Schraube /
 * Screw

5*120 mm

8 St./Pcs

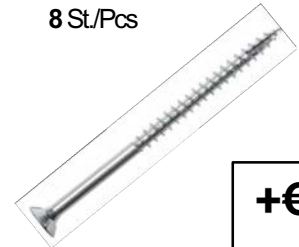

+€

Fundamentplan / Foundation Plan

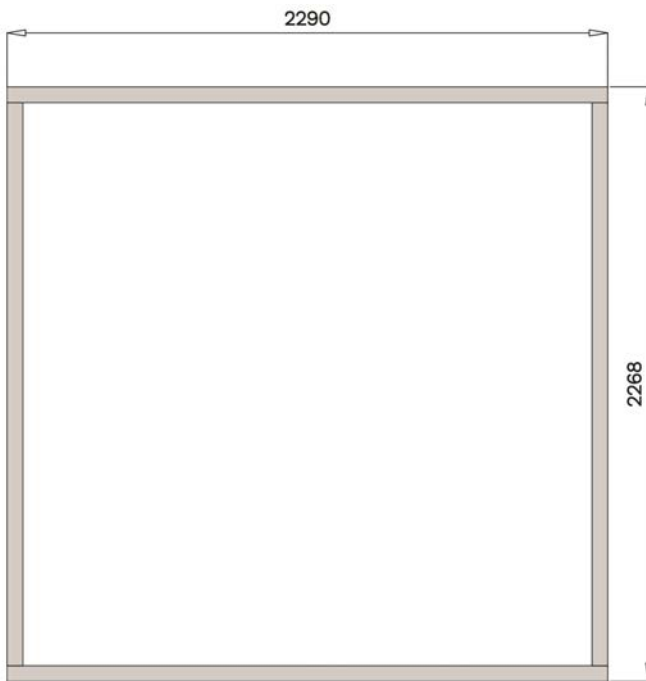

Imprägniertes Kantholz /
 Impregnated beam

Unterlegpads /
 Patio pads

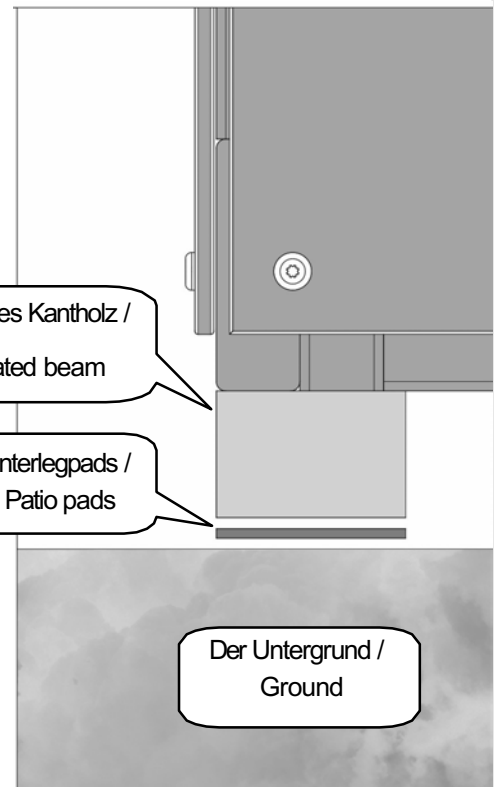

Der Untergrund /
 Ground

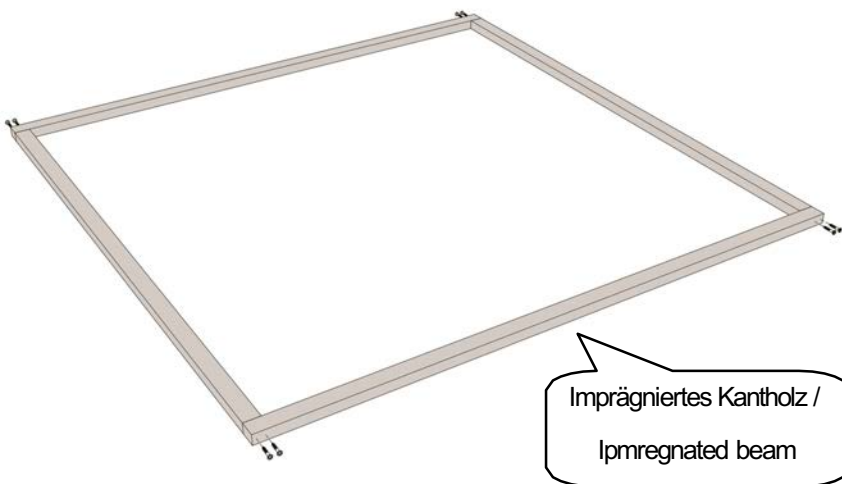

Imprägniertes Kantholz /
 Impregnated beam

Vor dem Aufbau!
 Erkundigen Sie sich vor der Montage, ob für den Bau eine Genehmigung erforderlich ist.
Before installation!
 Prior to assembly please check wheter a permit is required.

HPL 2

32.

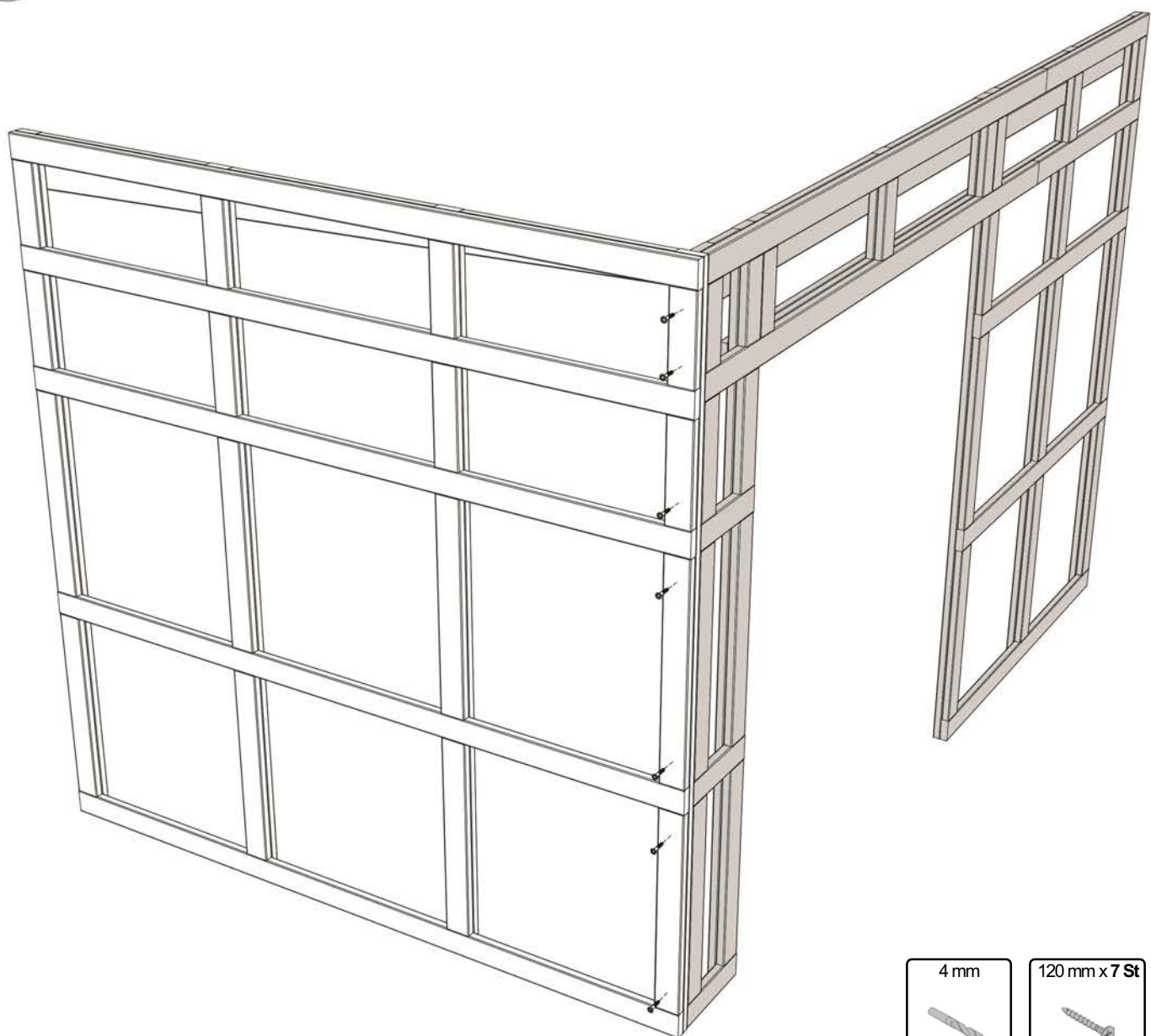

4 mm



120 mm x 7 St



32.1

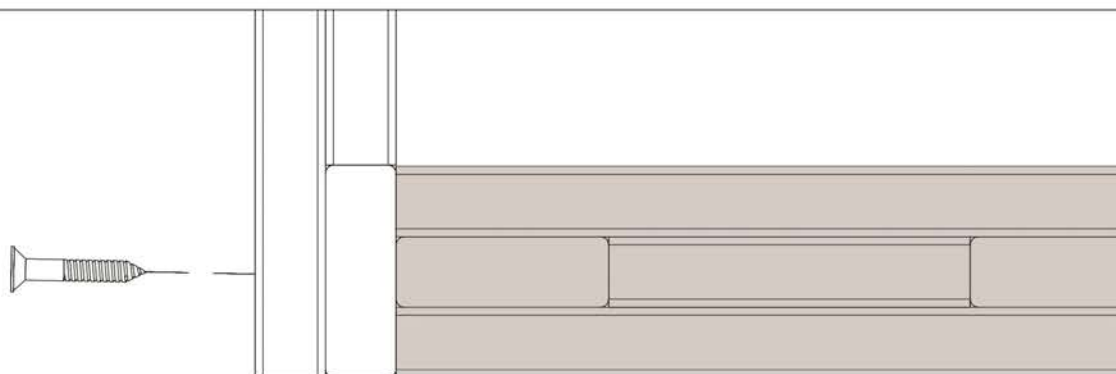

HPL 2

33.

4 mm



120 mm x 7 St

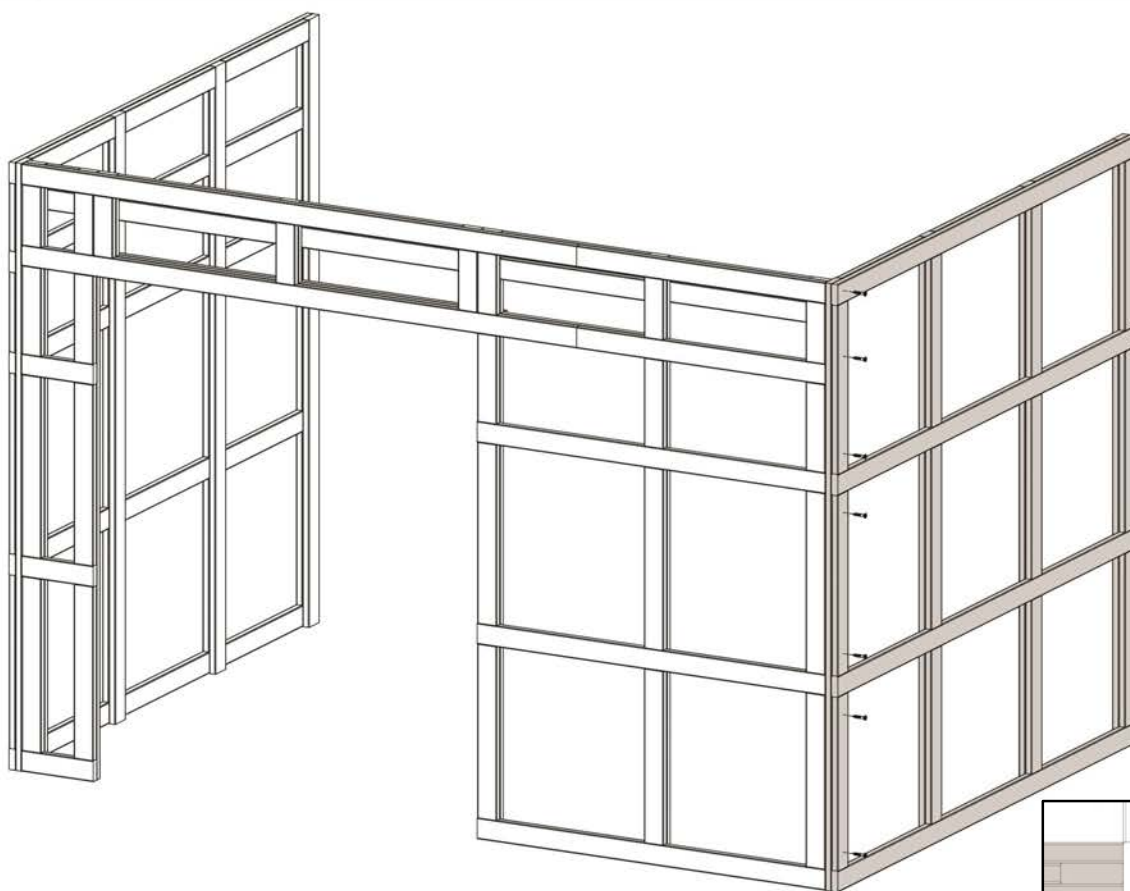

34.

4 mm



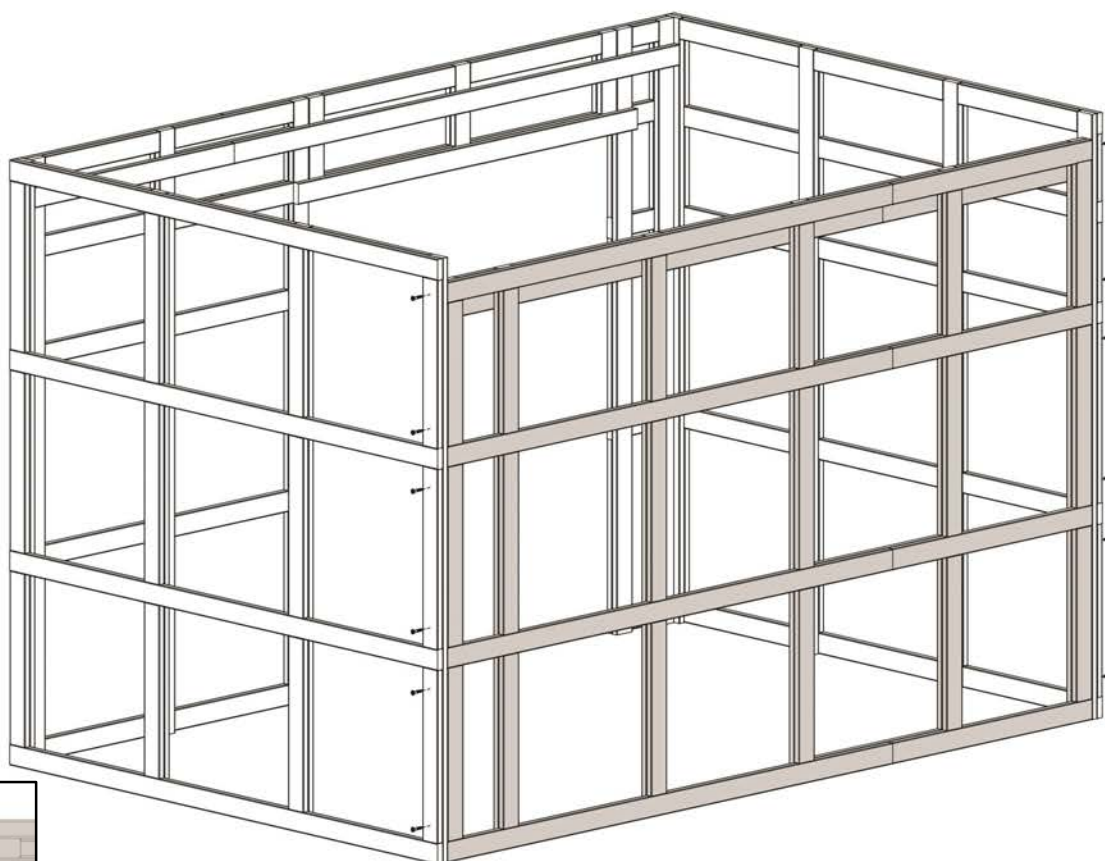

120 mm x 14 St

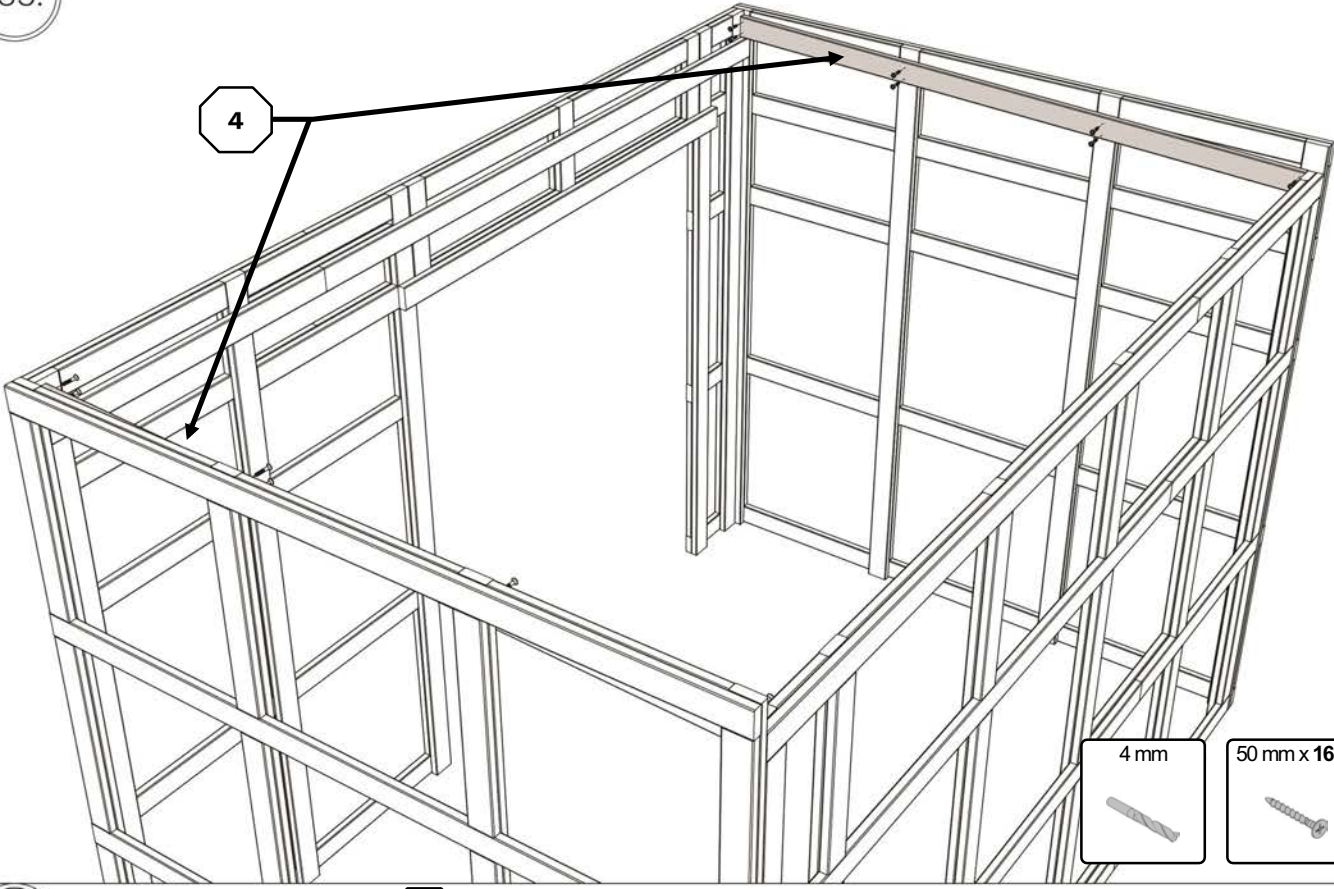

HPL 2

35.



4 mm	50 mm x 16 St
	

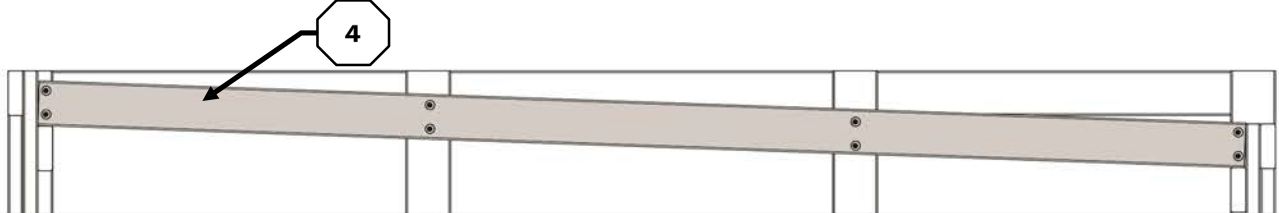

35.1

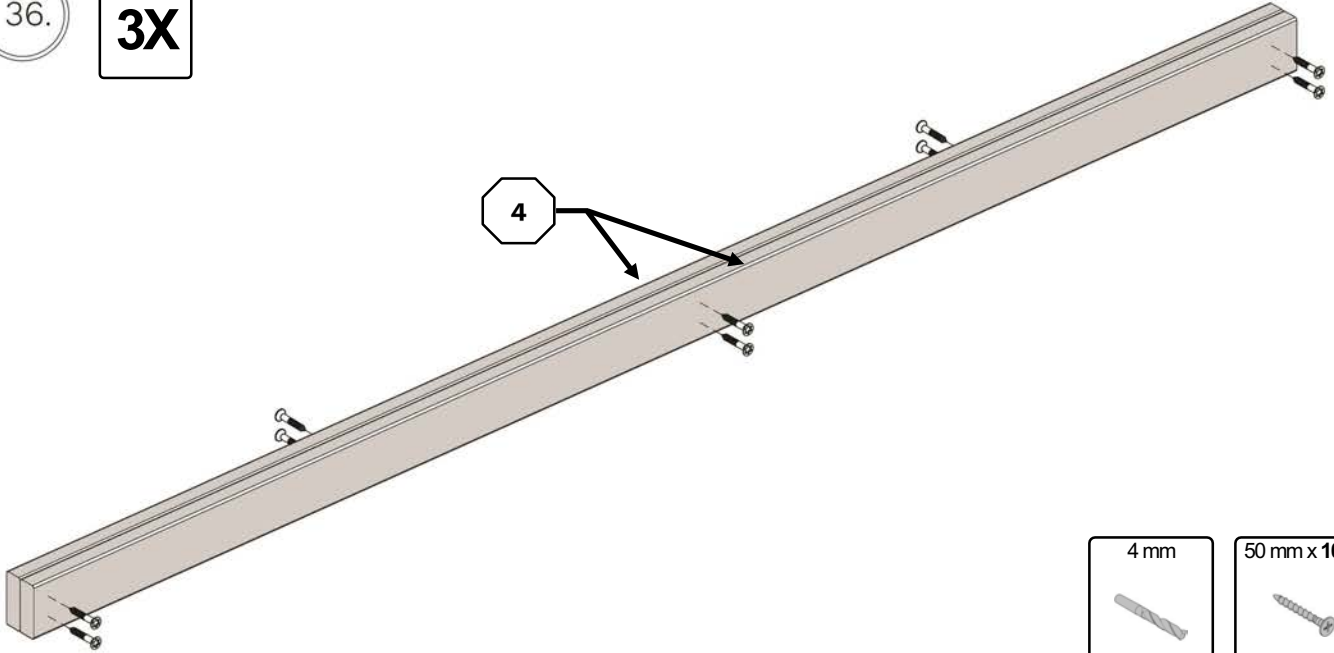

36.

3X



4 mm	50 mm x 10 St
	

HPL 2

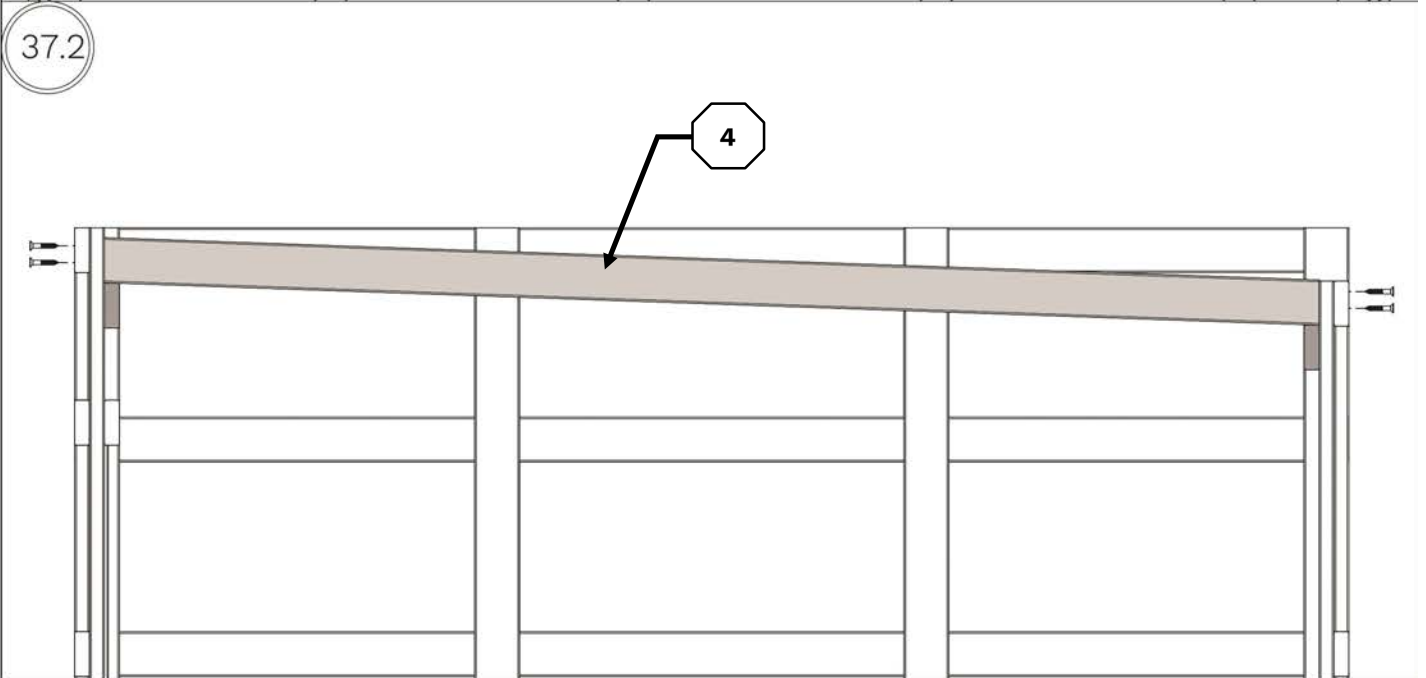
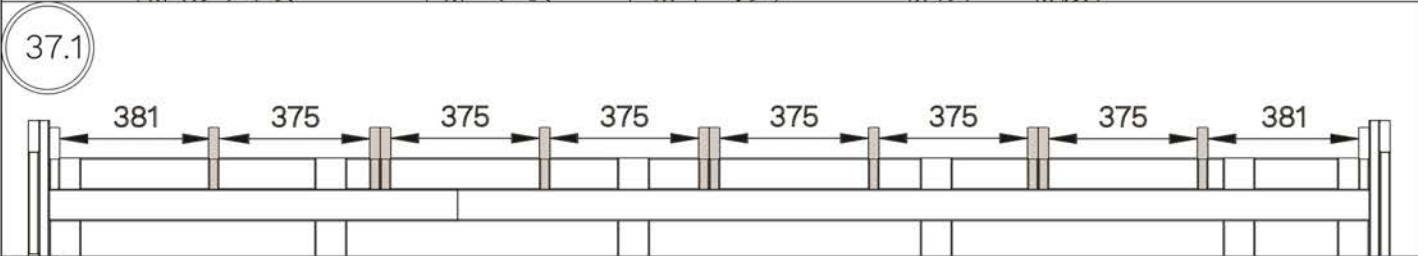
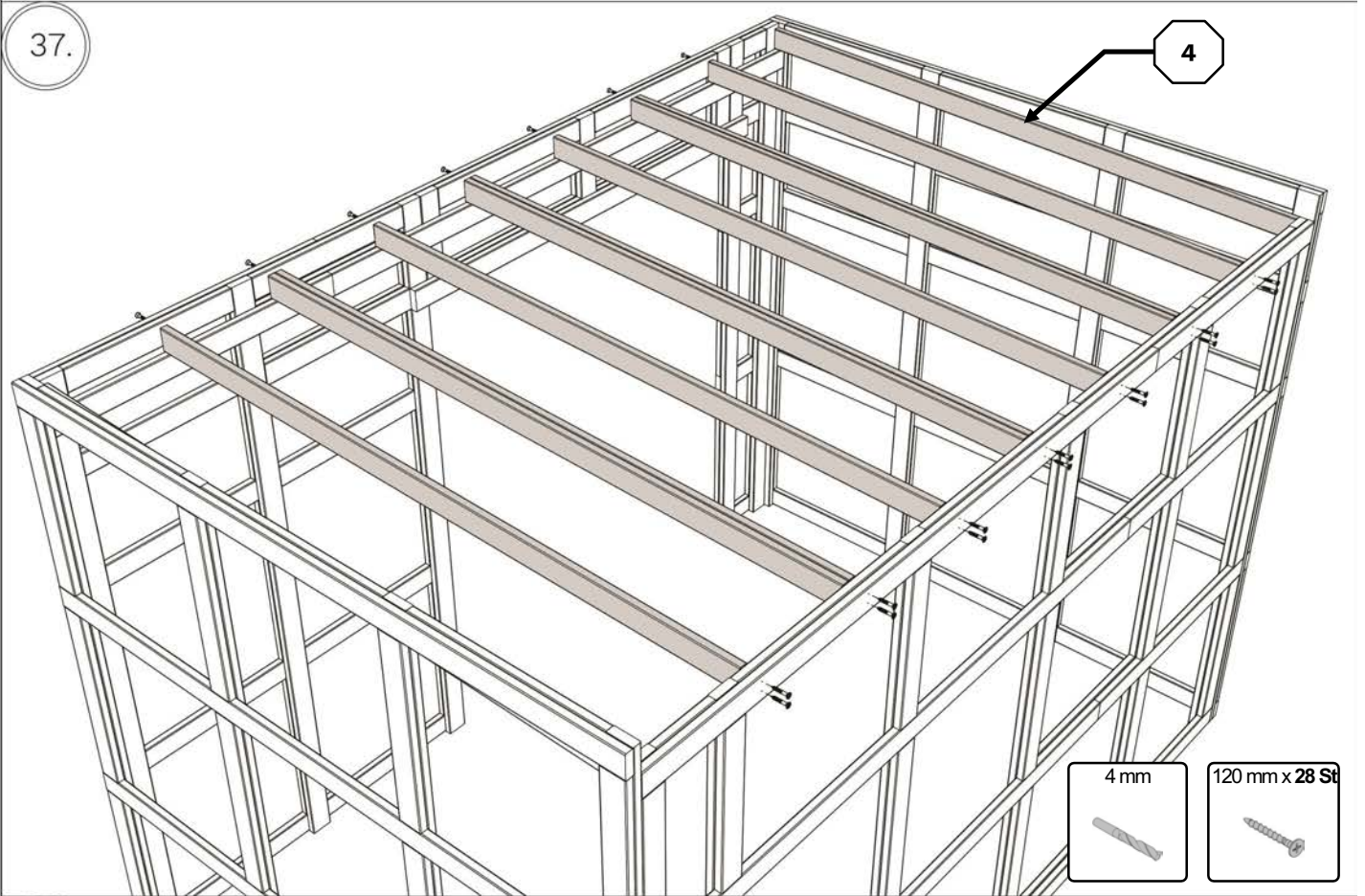

HPL 2

38.

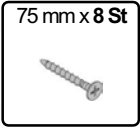
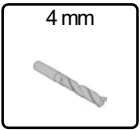
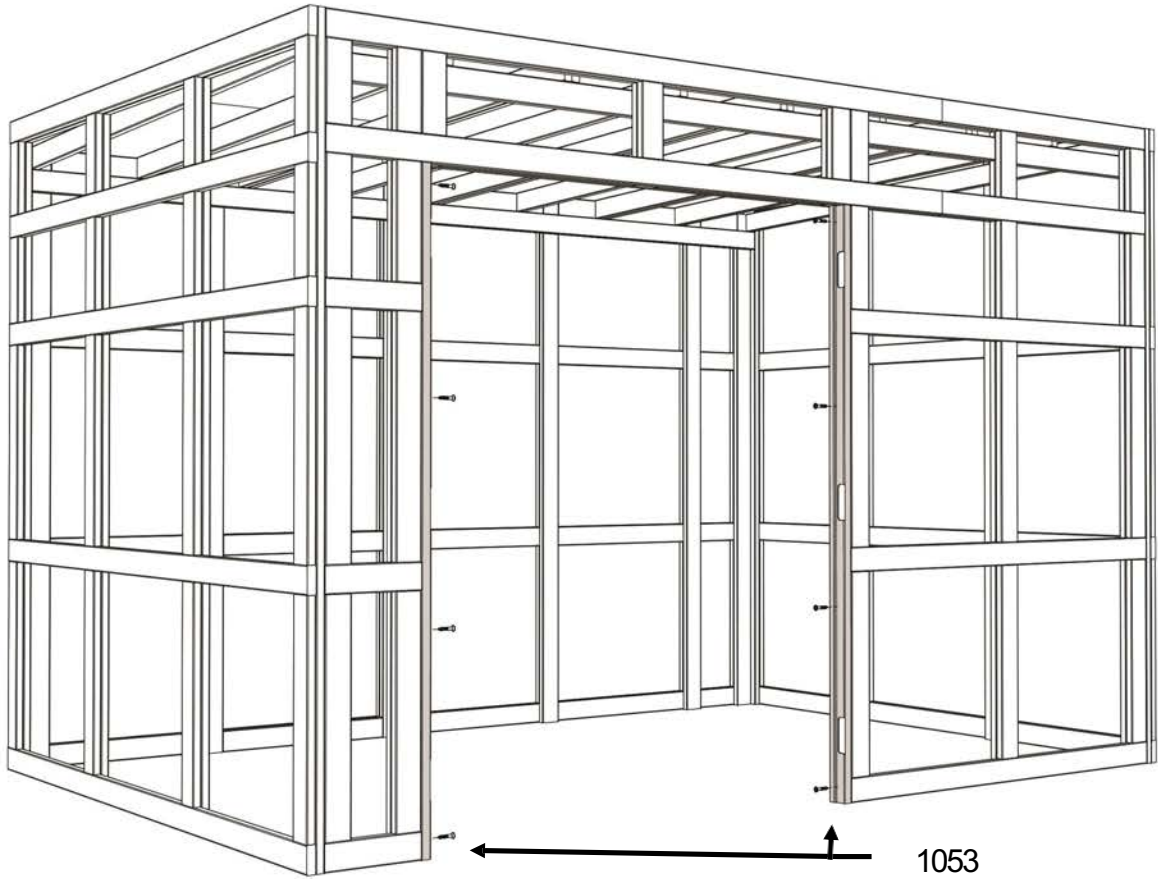

38.1

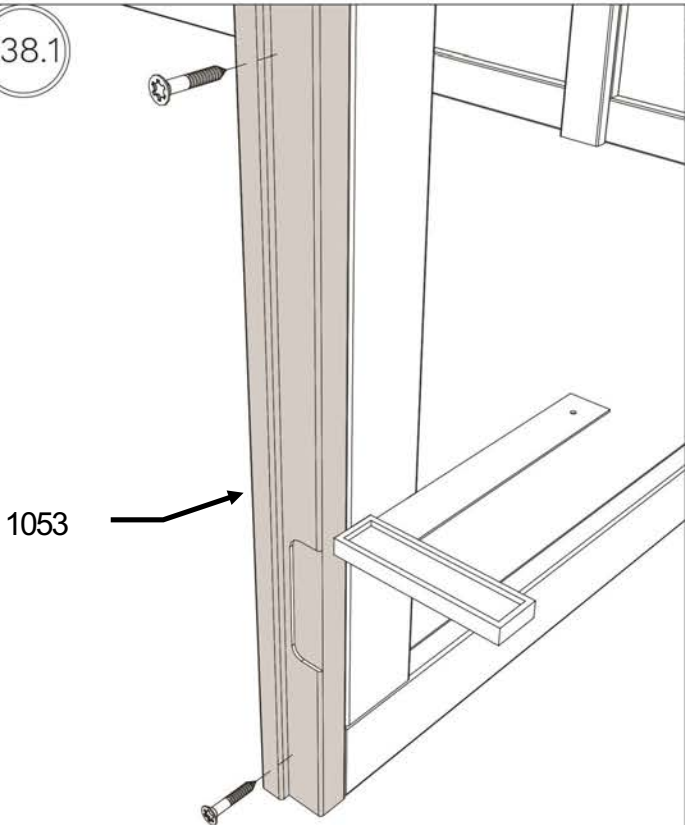

39.

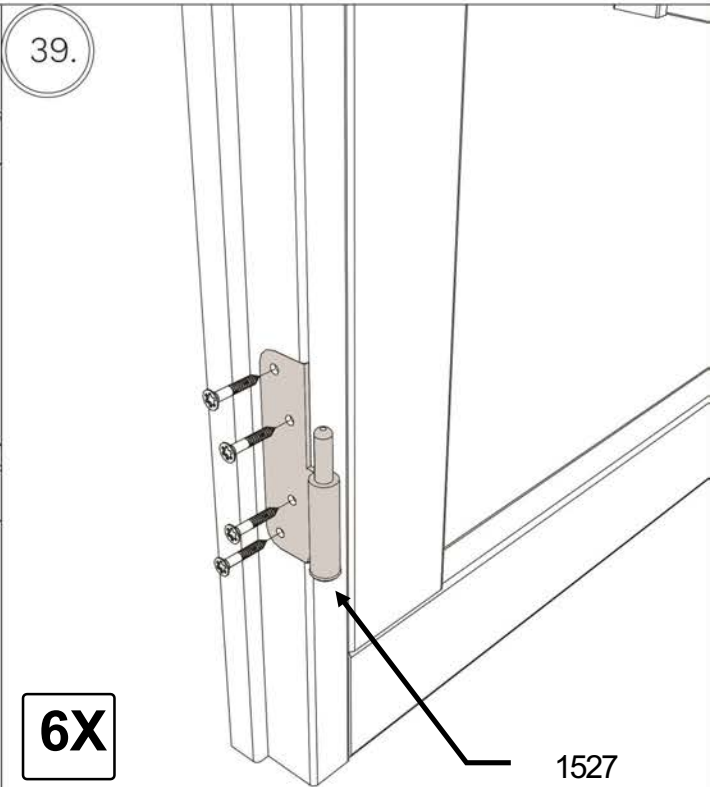

6X

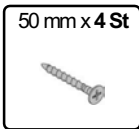

HPL 2

40.

35 mm x 12 St



516

5 mm

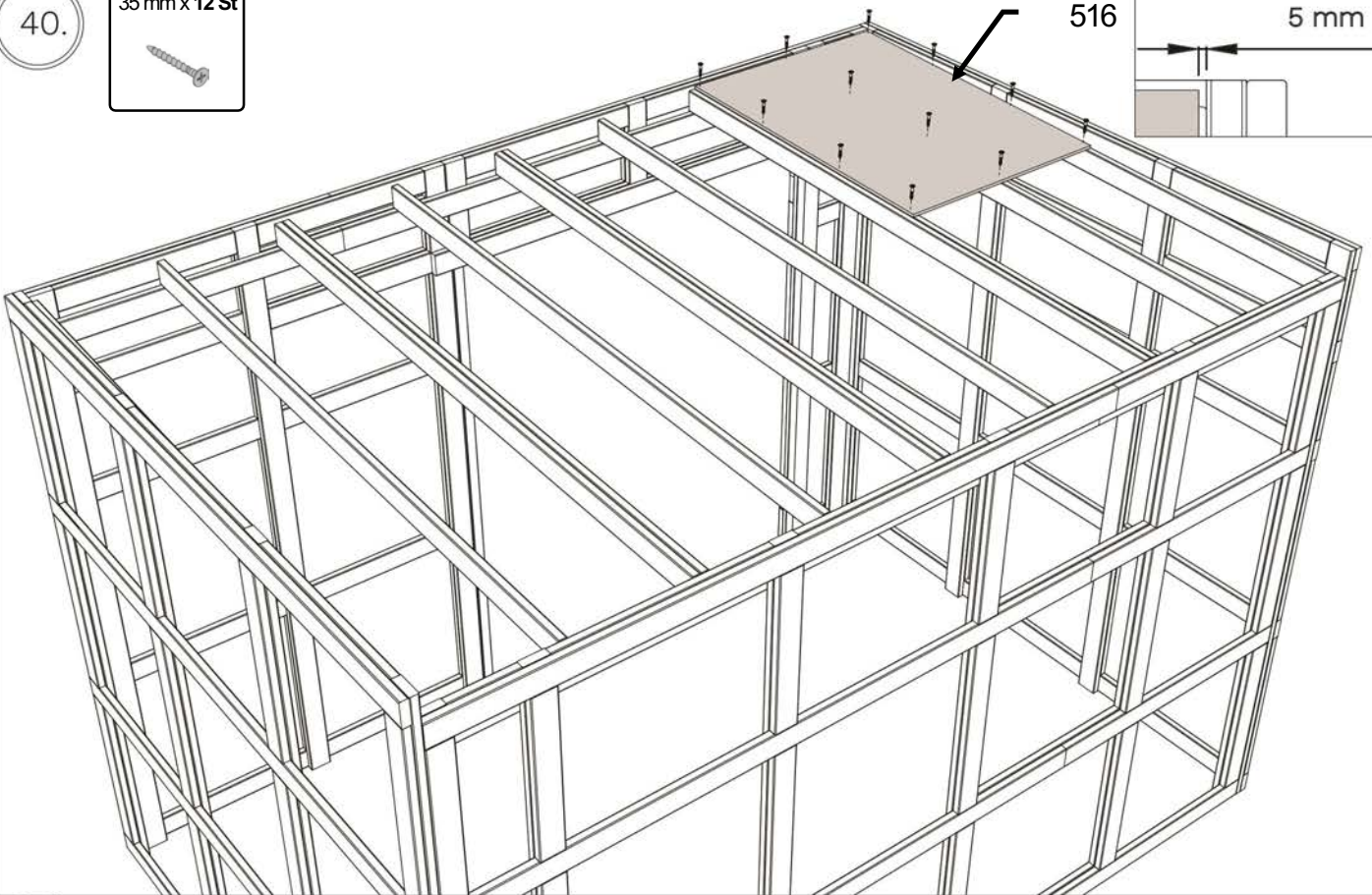
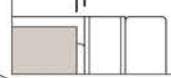

41.

516

35 mm x 36 St

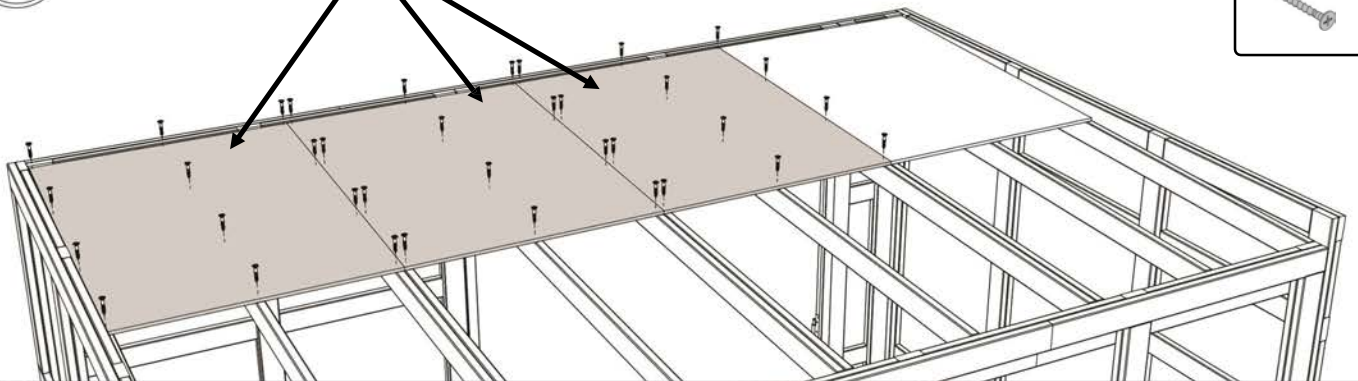

42.

516

516

35 mm x 48 St

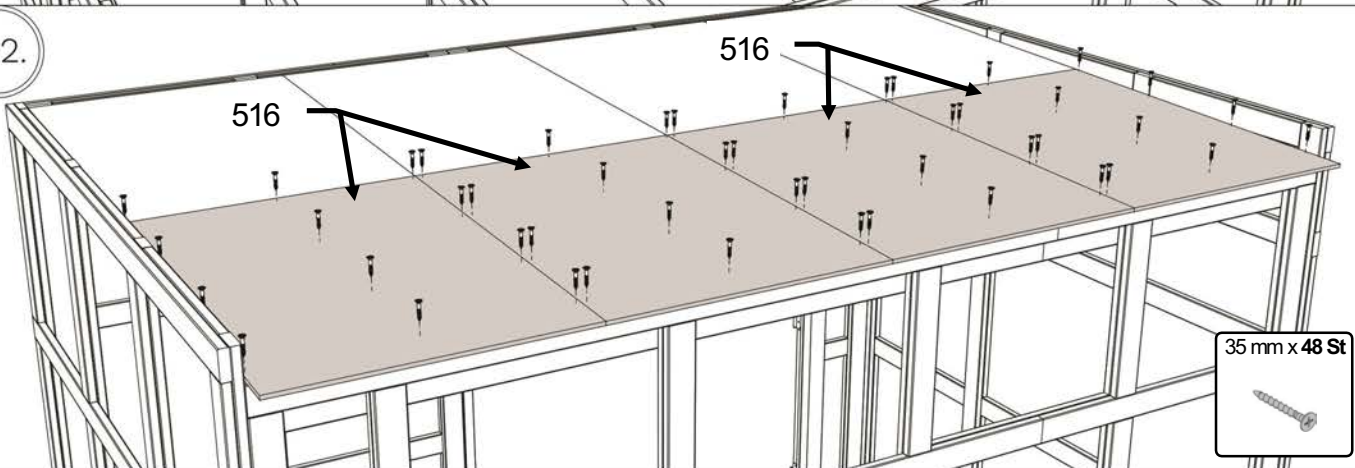

HPL 2



2 Hours



HPL 2

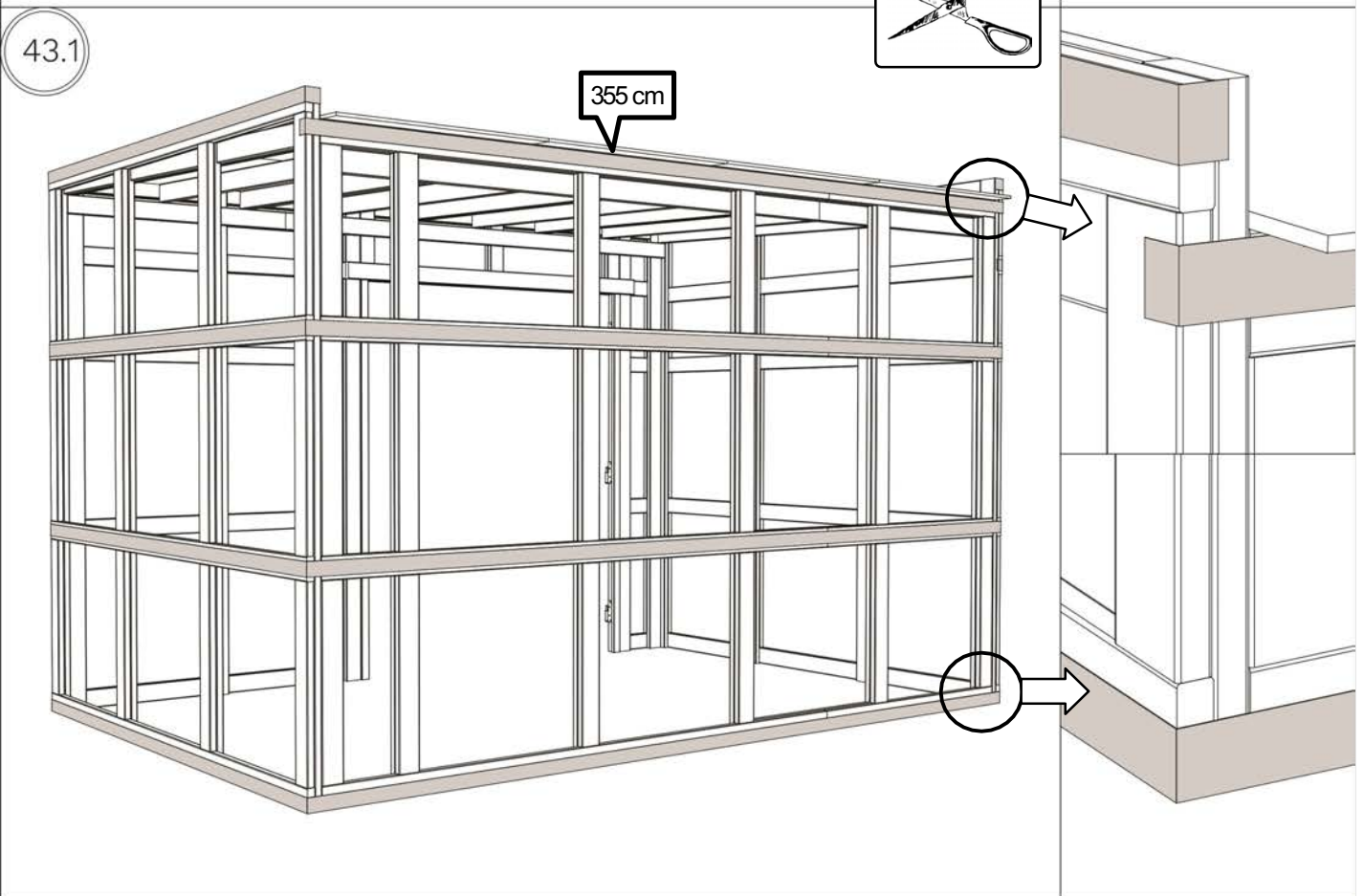
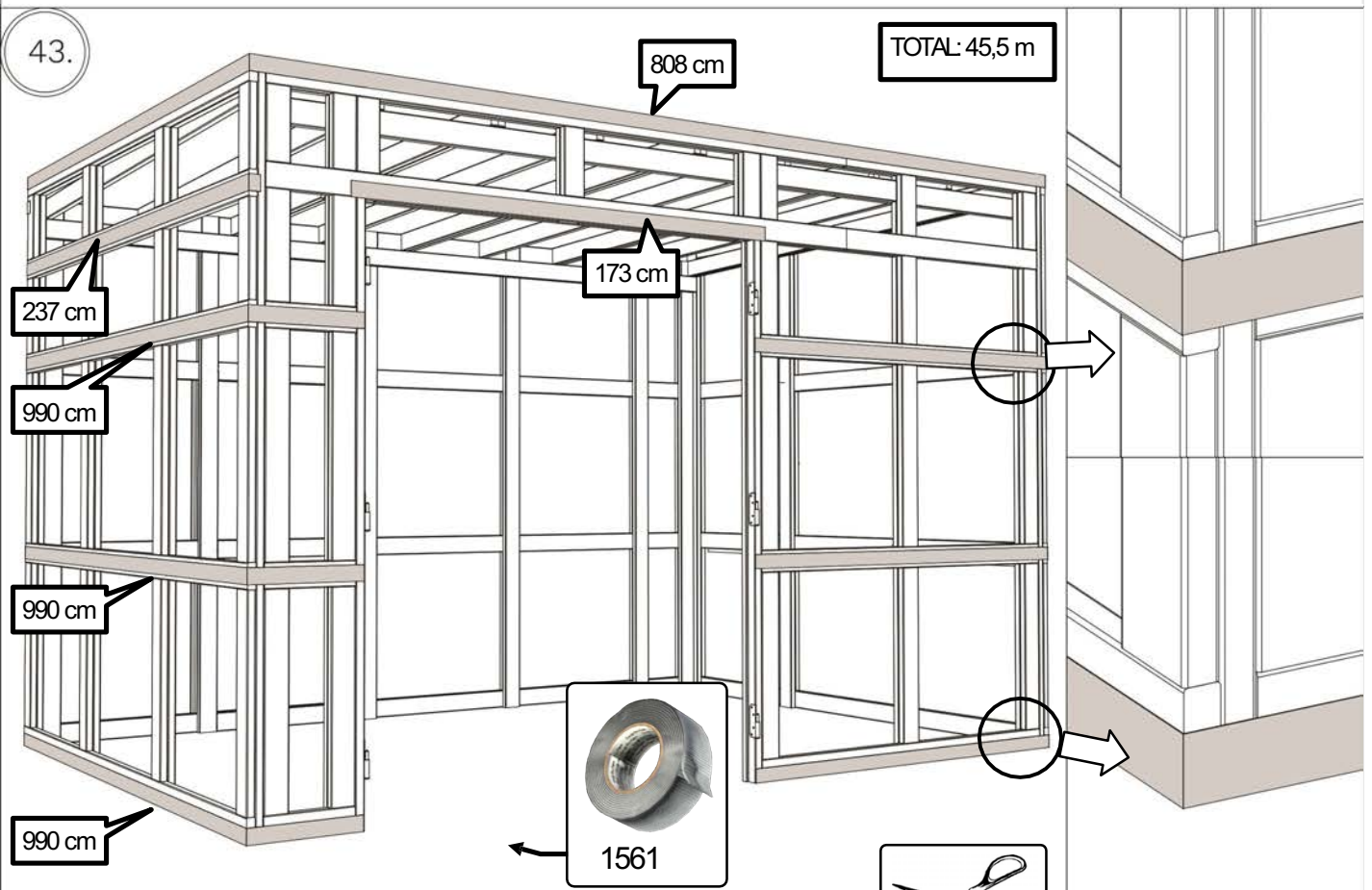

HPL 2



4 Hours

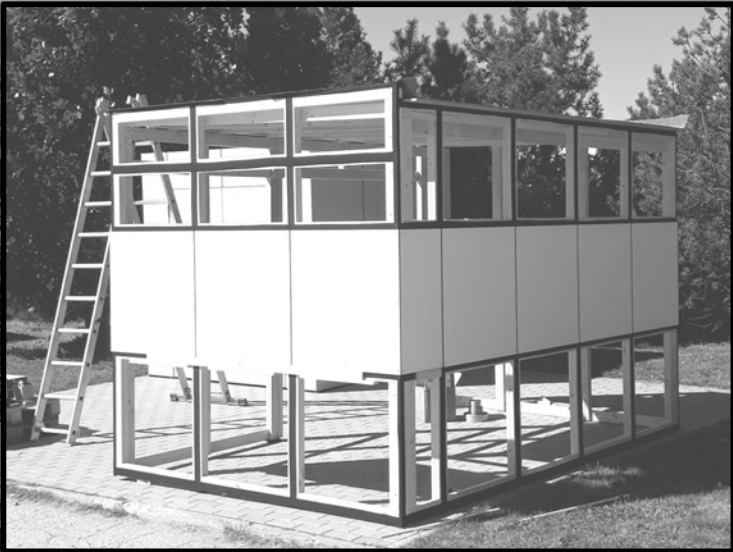

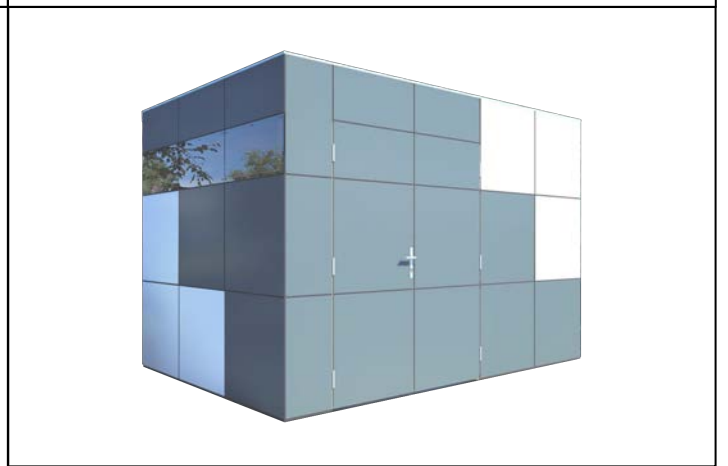
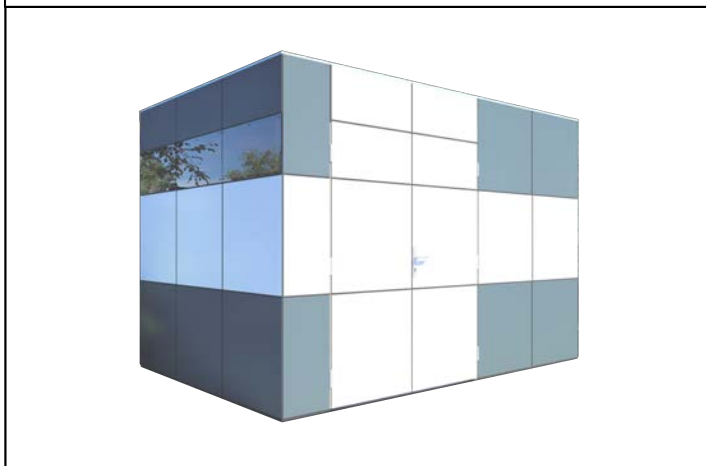
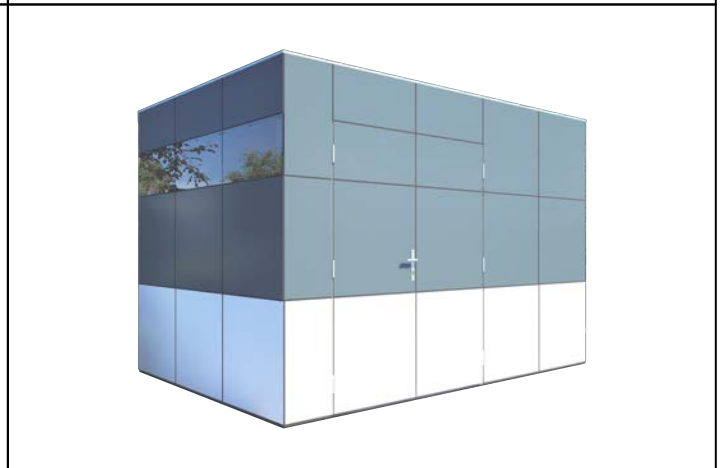
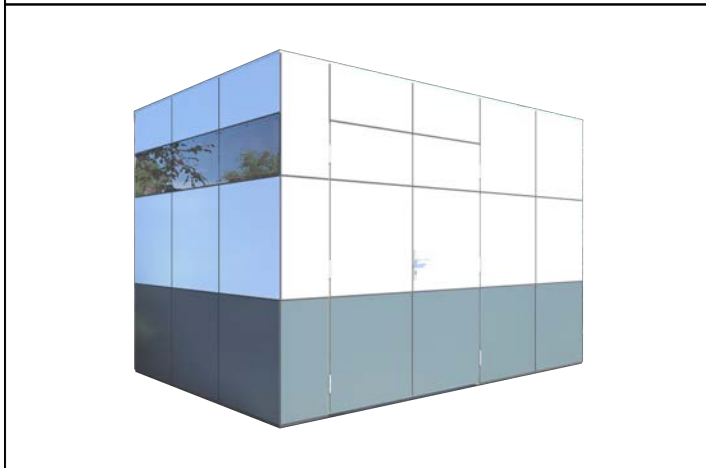
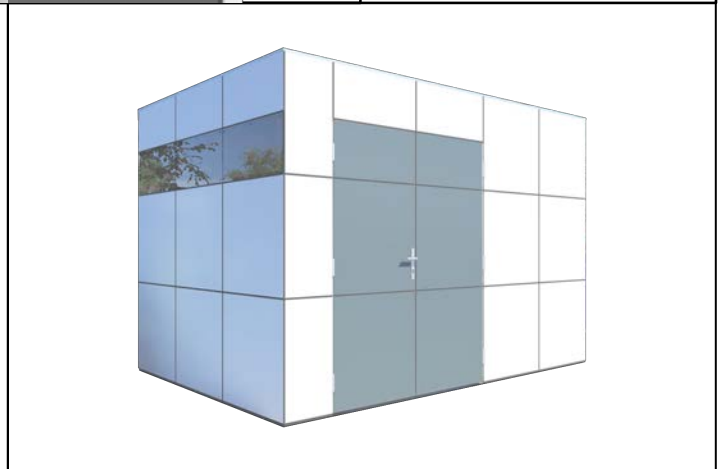
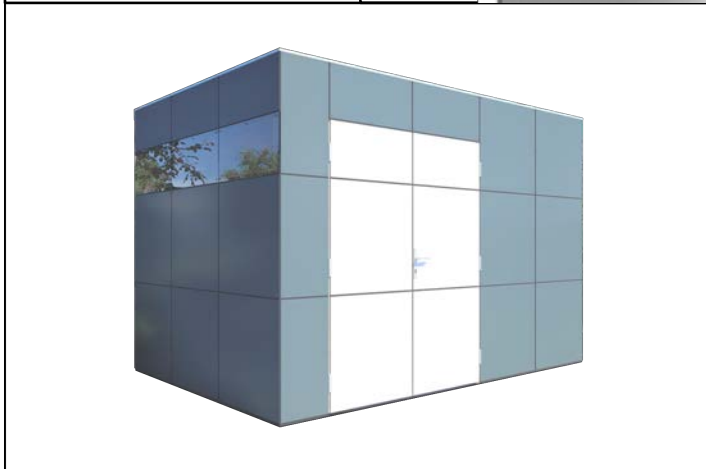
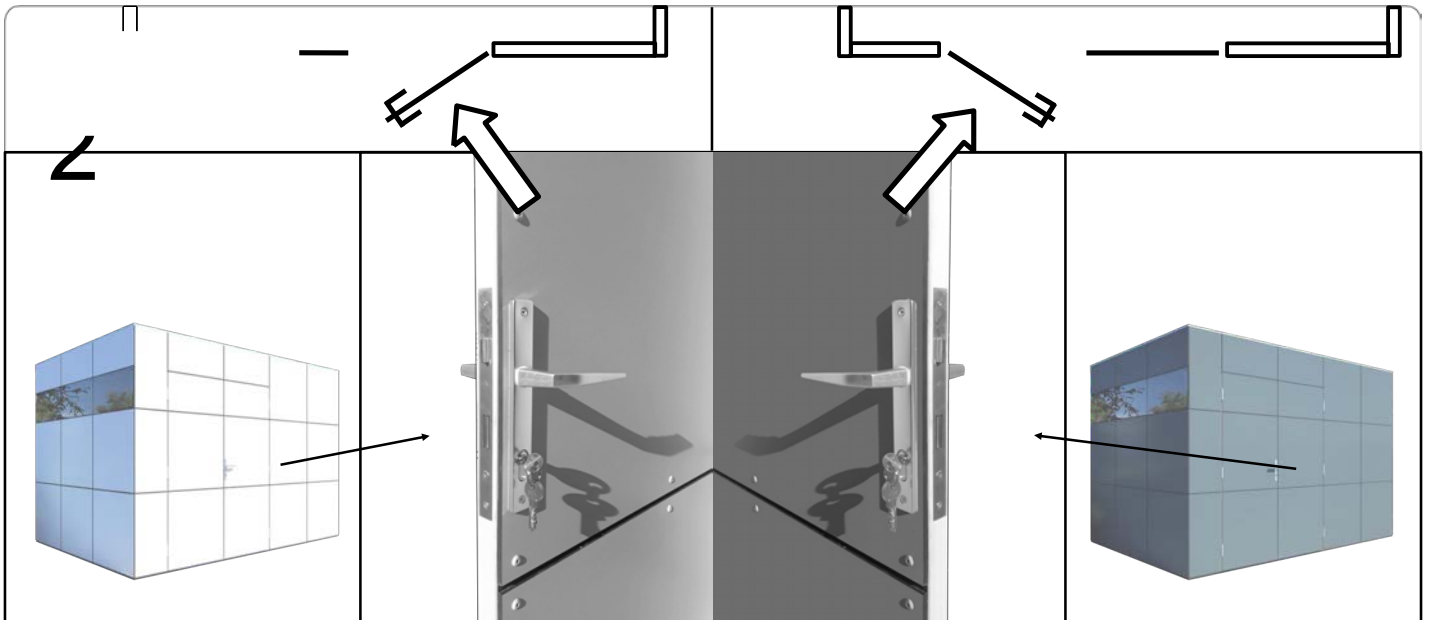

HPL 2

Create your own design! Erstellen Sie Ihr eigenes Design! Créez votre propre design! Creëer je eigen ontwerp!

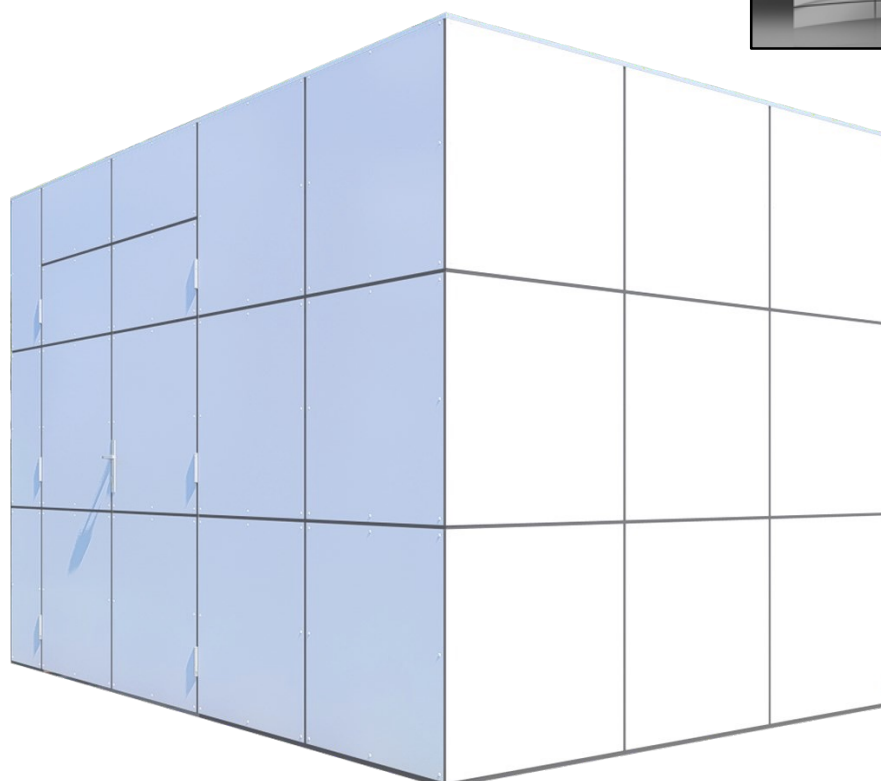
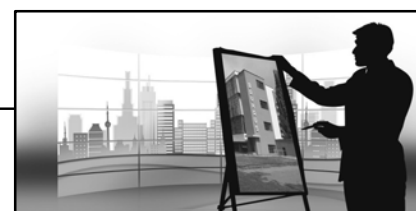
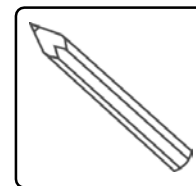
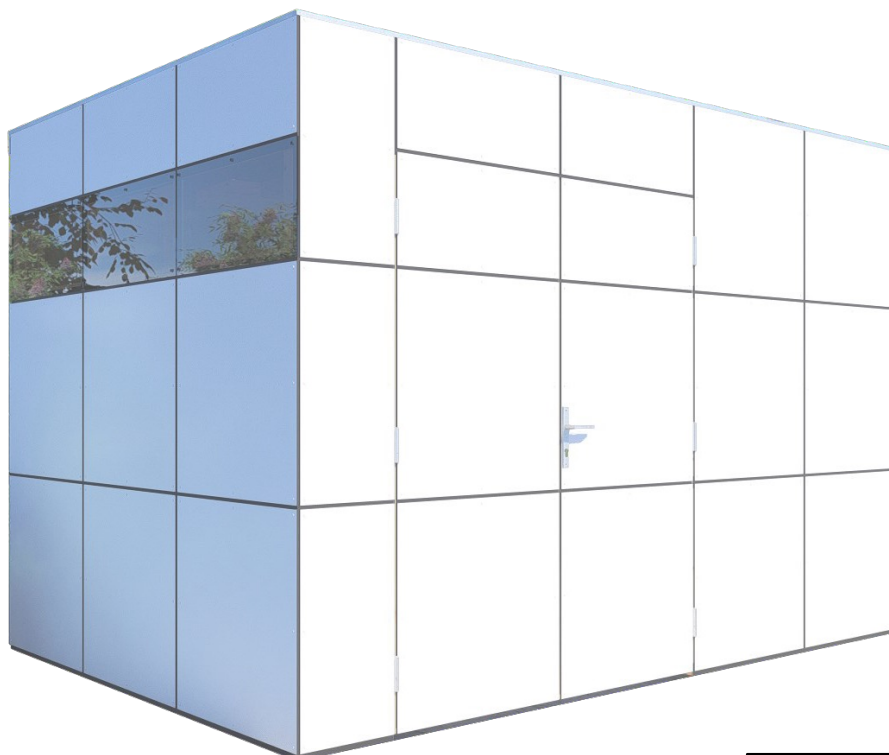

HPL 2

45.

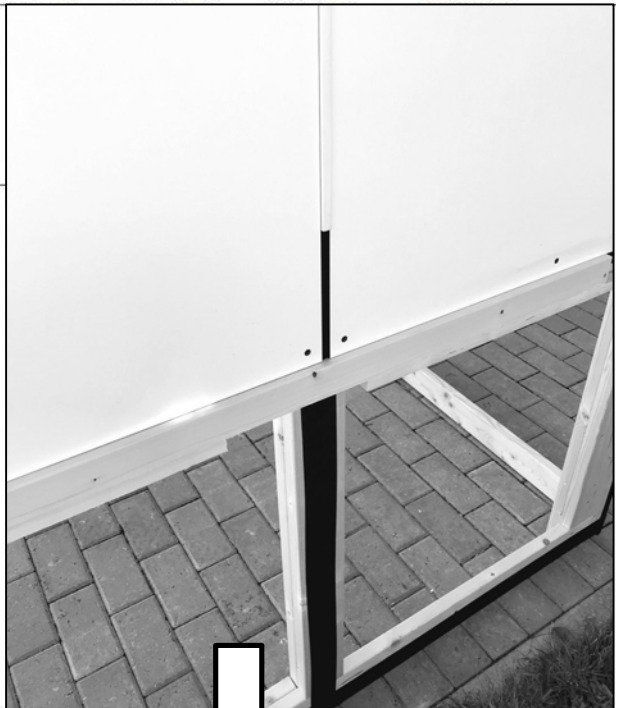
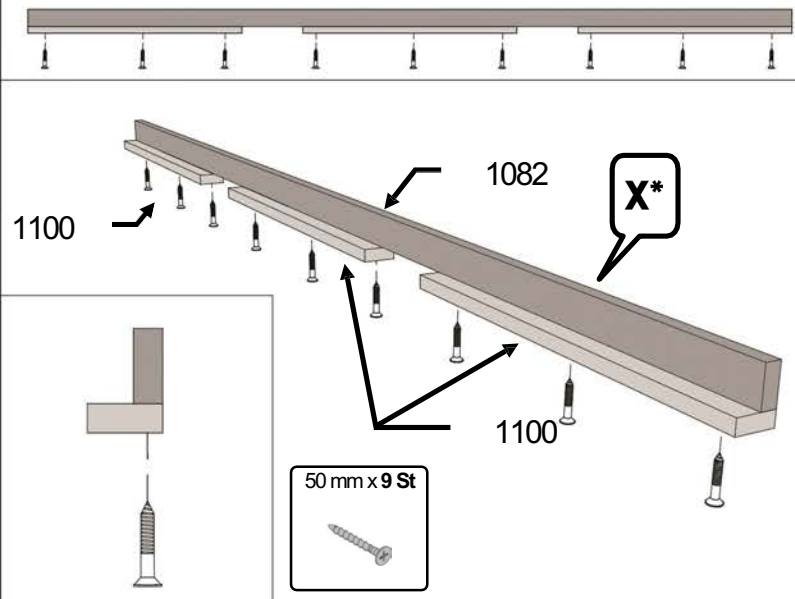



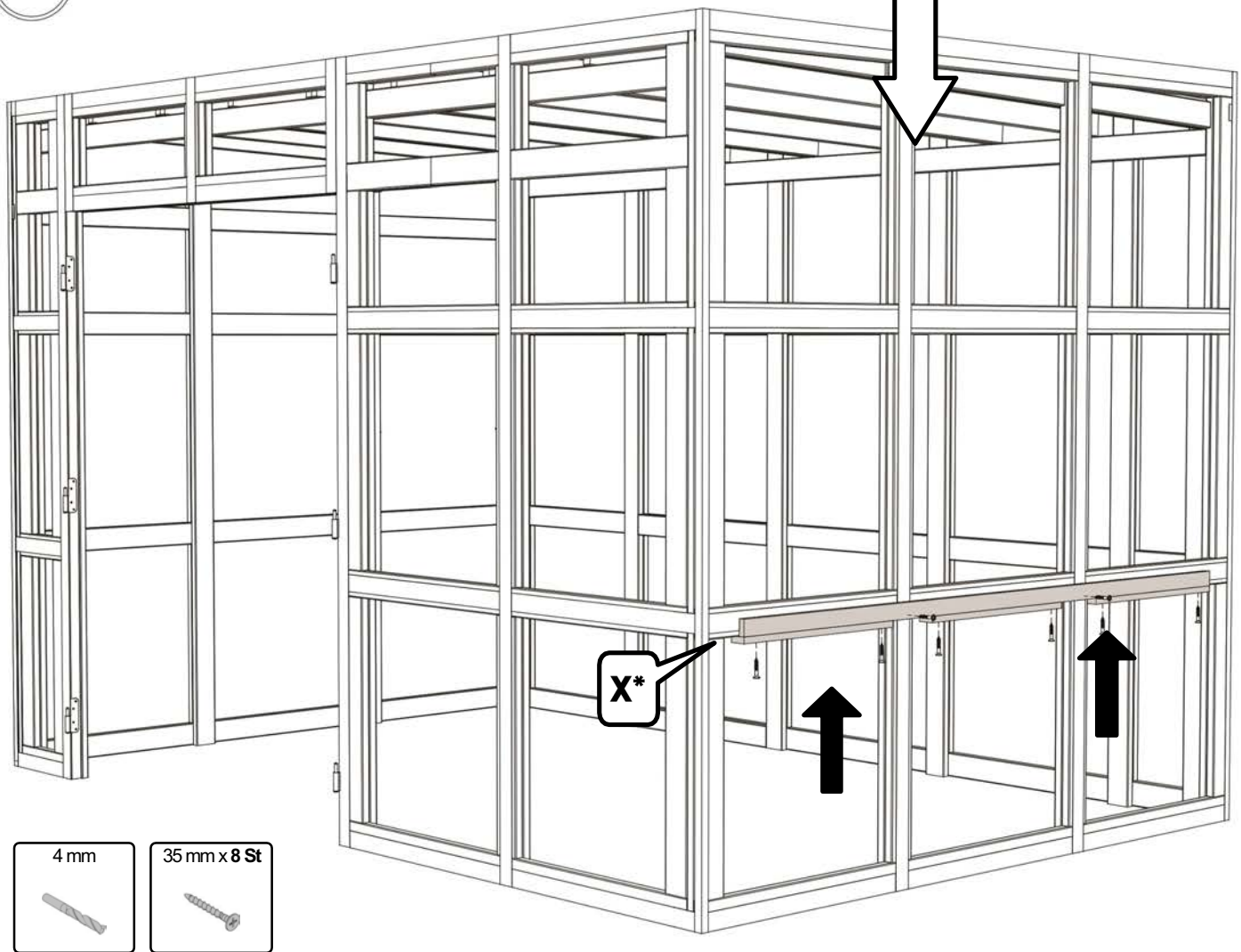

46.

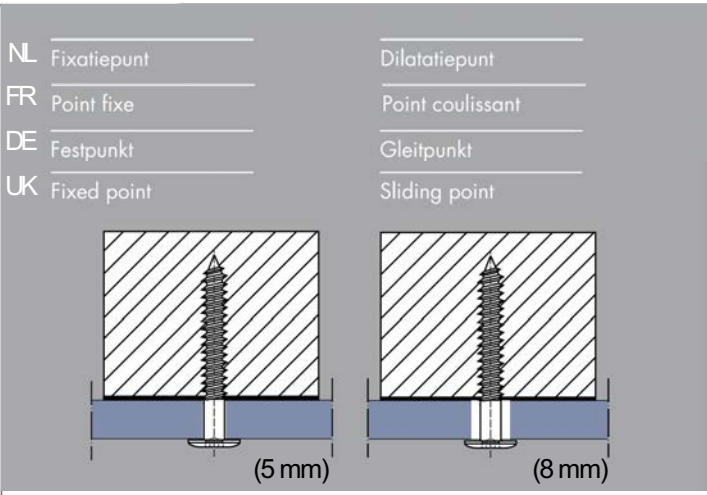
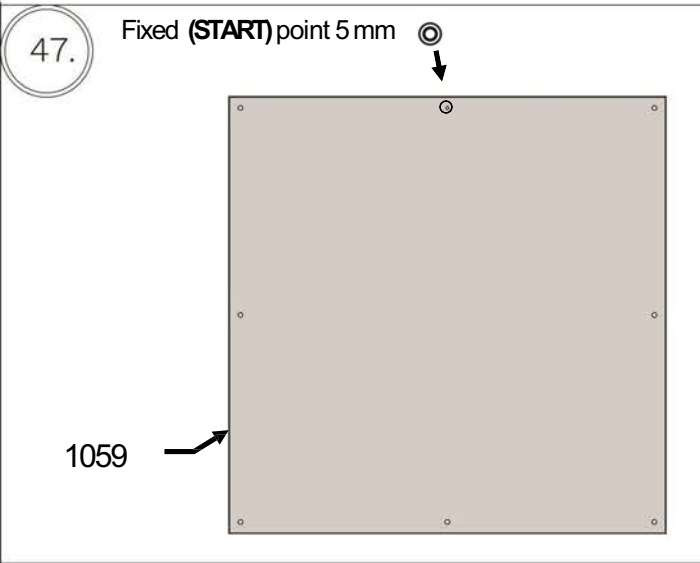





HPL 2



UK  = fixed point in panel centre
 = sliding point
 Screws must always be centered in the holes and must not be over tightened.

NL  = fixatiepunt in het midden van het paneel
 = dilatatiepunt
 De schroeven moeten altijd in de boorgaten gecentreerd worden en mogen niet te vast worden aangedraaid.

FR  = point fixe au centre du panneau
 = point coulissant
 Les vis doivent être impérativement centrées dans les trous et ne pas être serrées excessivement.

DE  = Festpunkt in der Plattenmitte
 = Gleitpunkt
 Schrauben müssen immer mittig im Loch platziert werden und dürfen nicht überzogen werden.

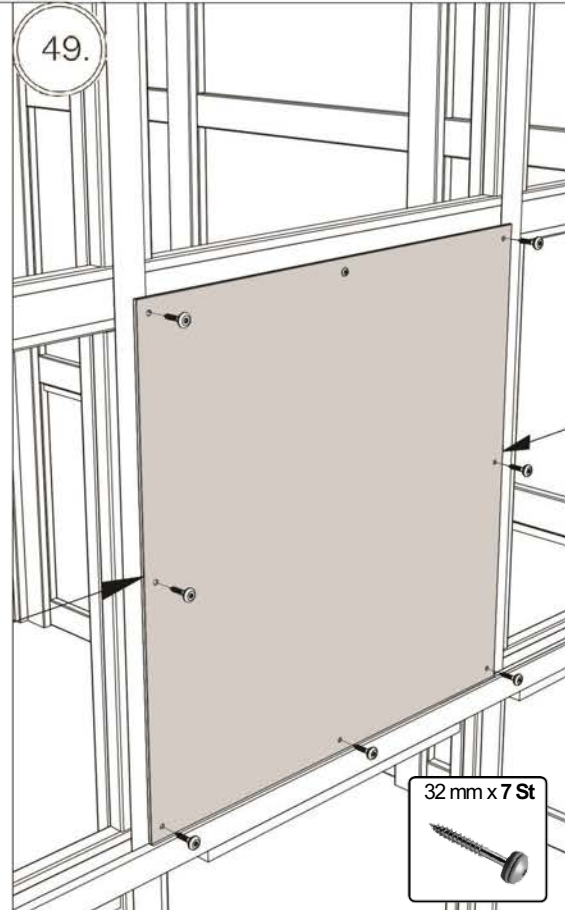
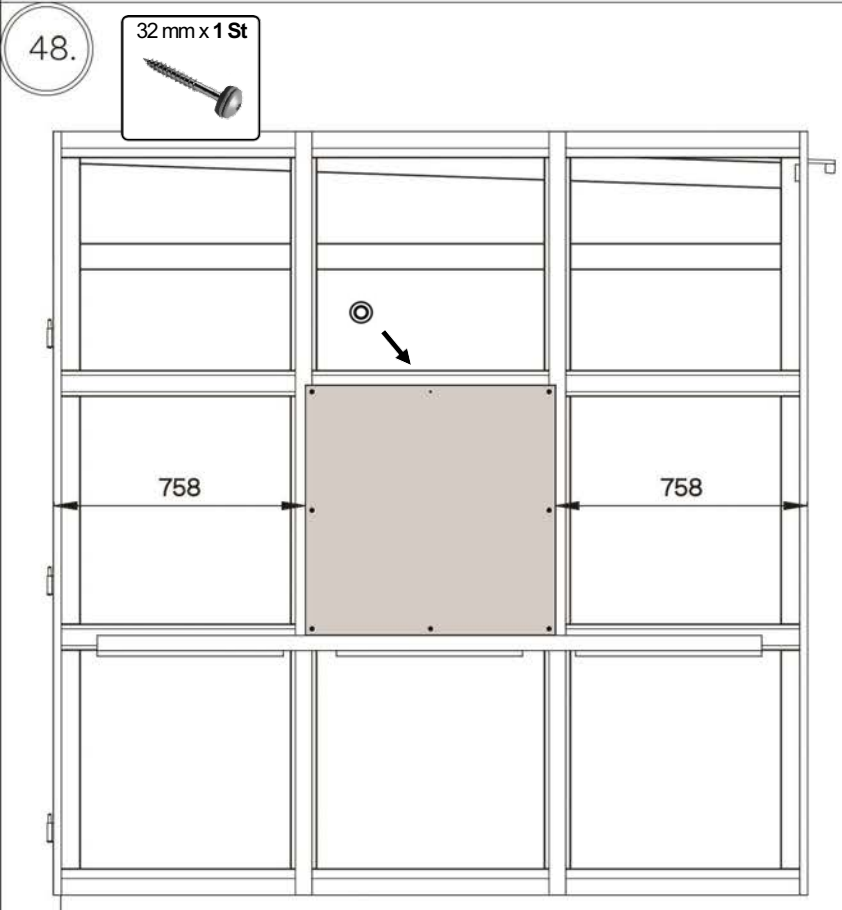

HPL 2

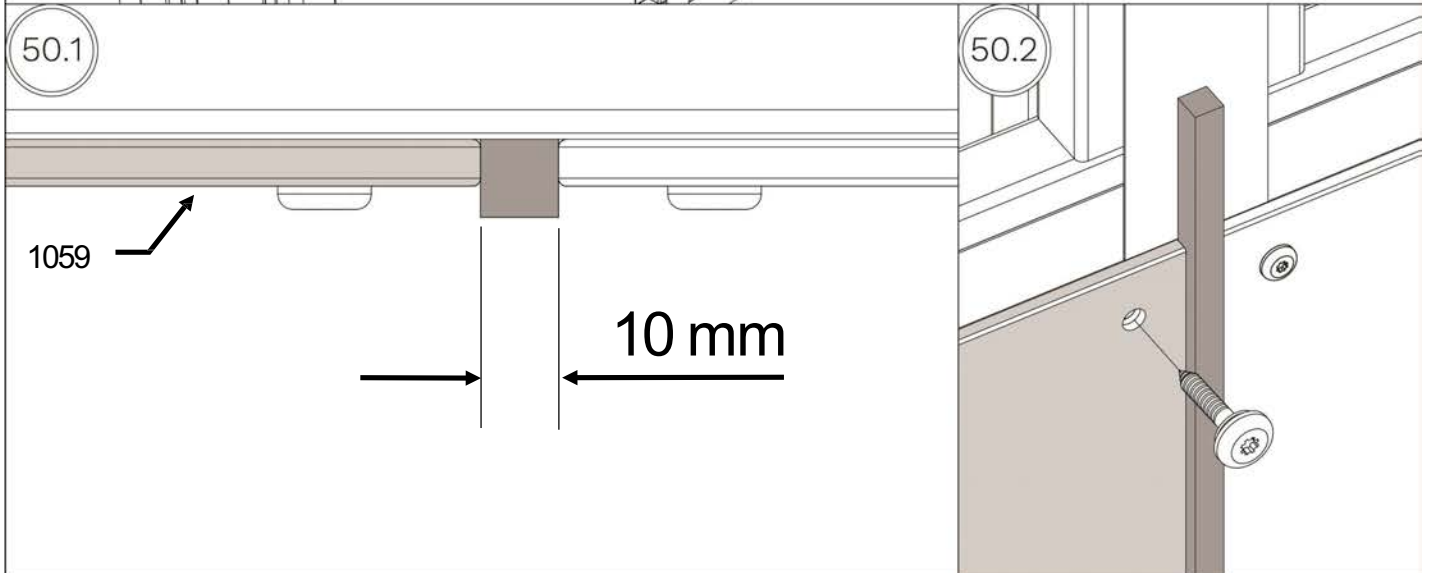
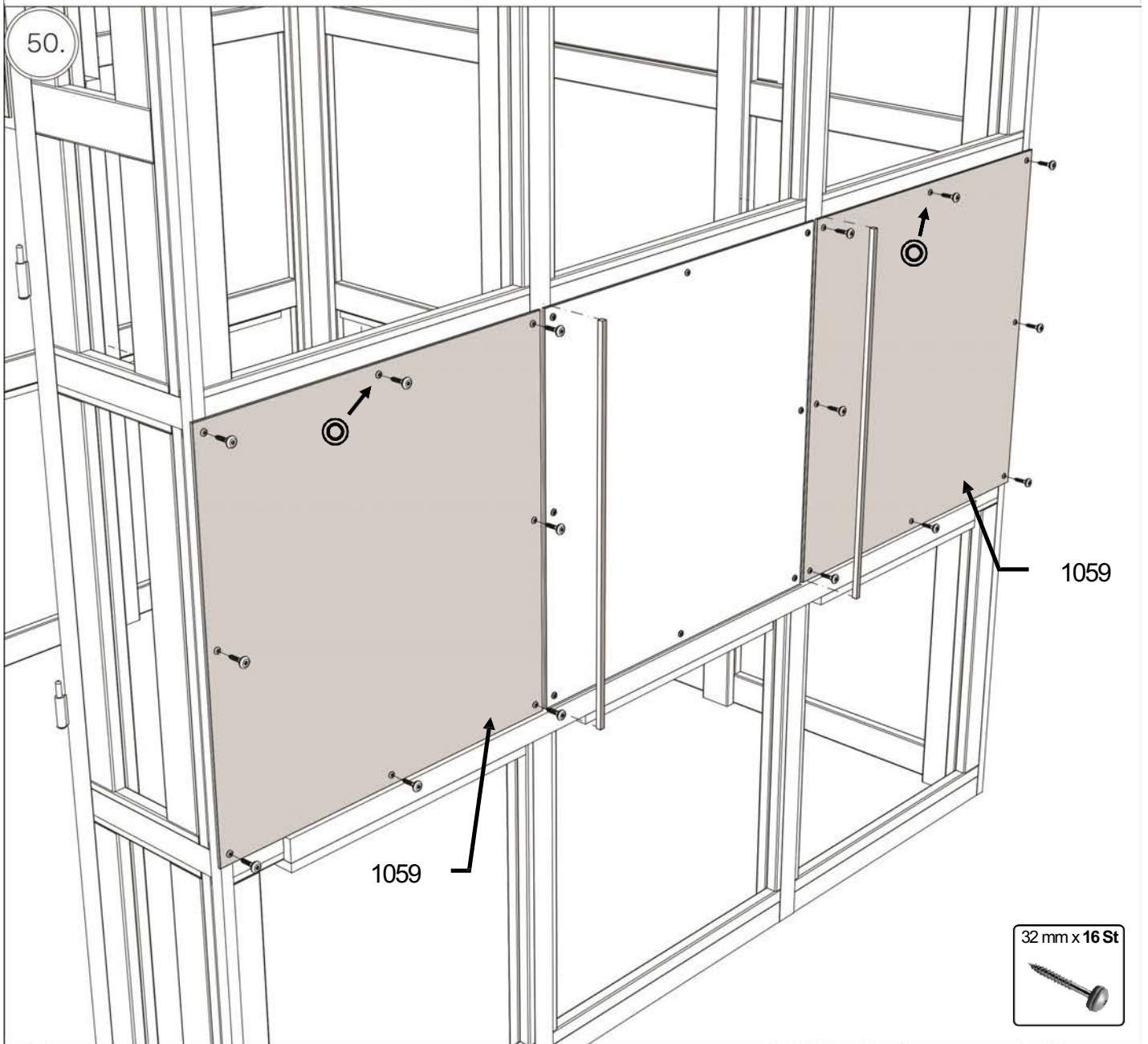

HPL 2

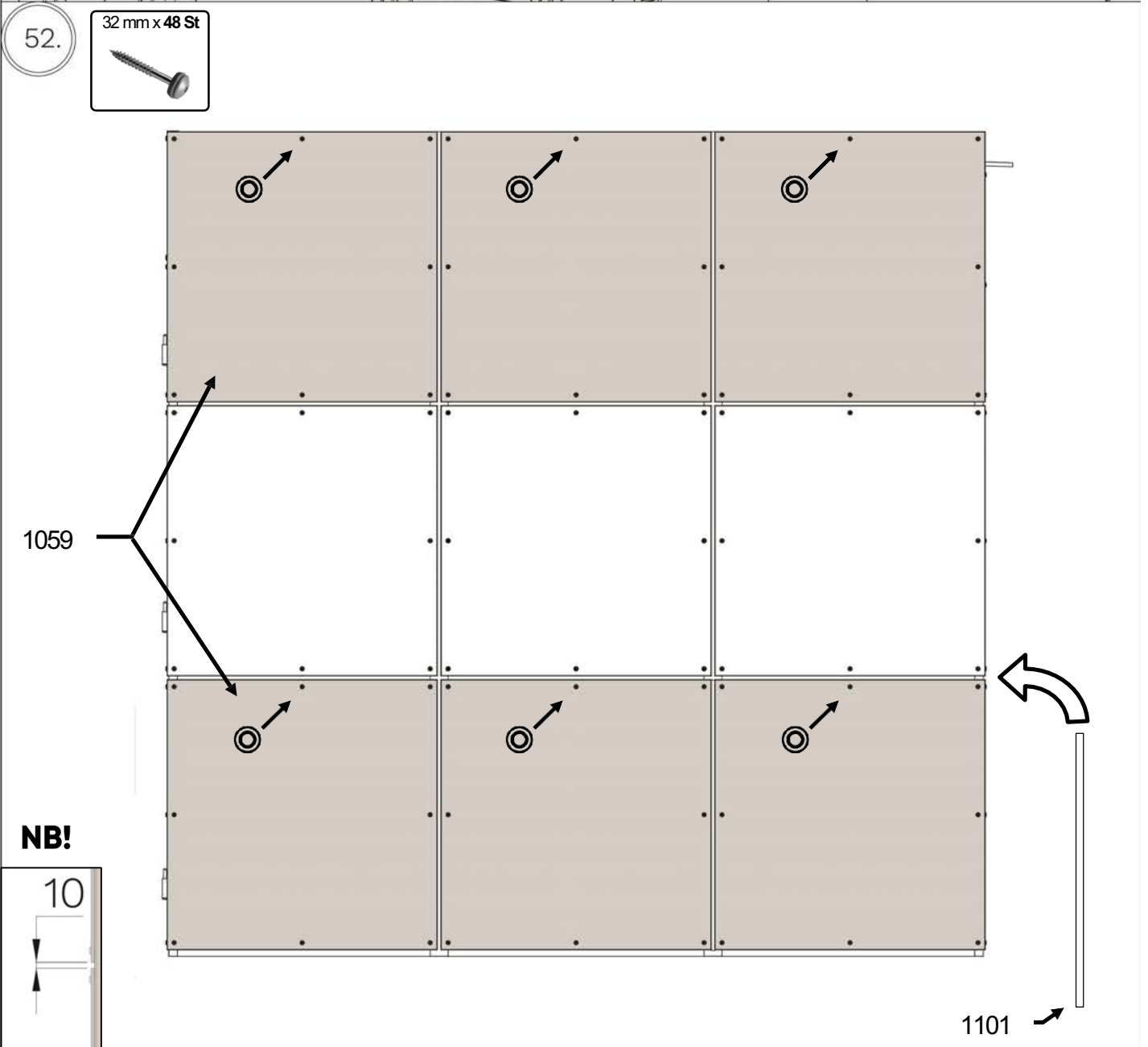
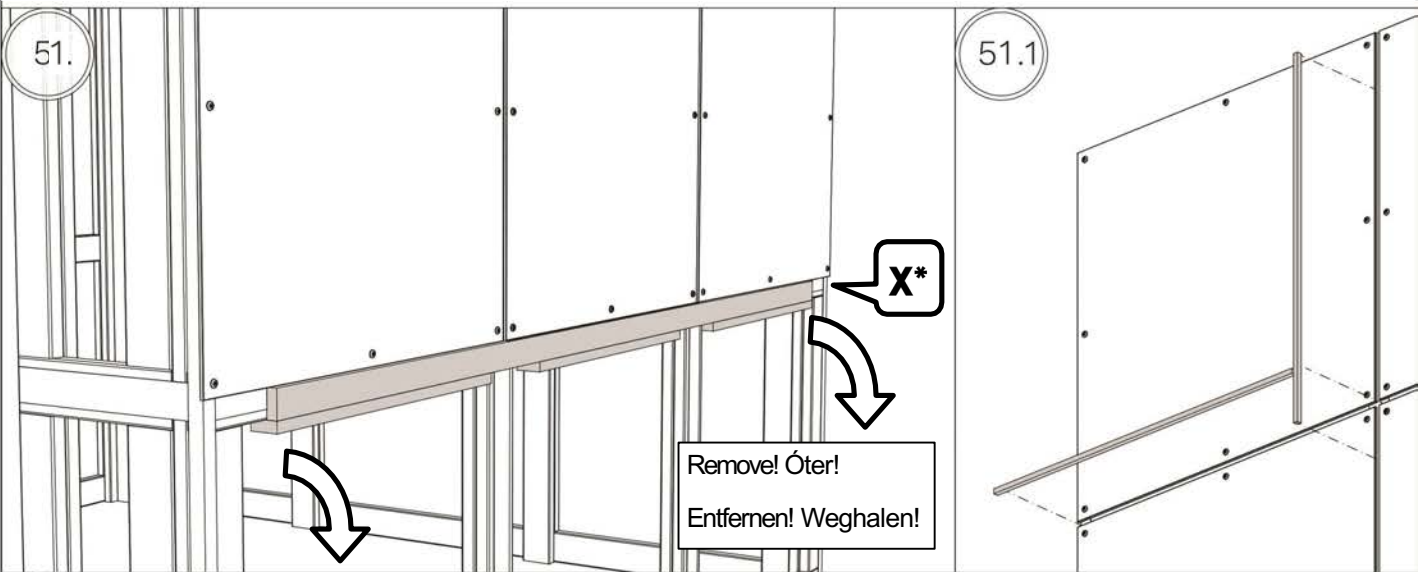

HPL 2

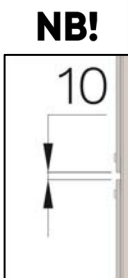
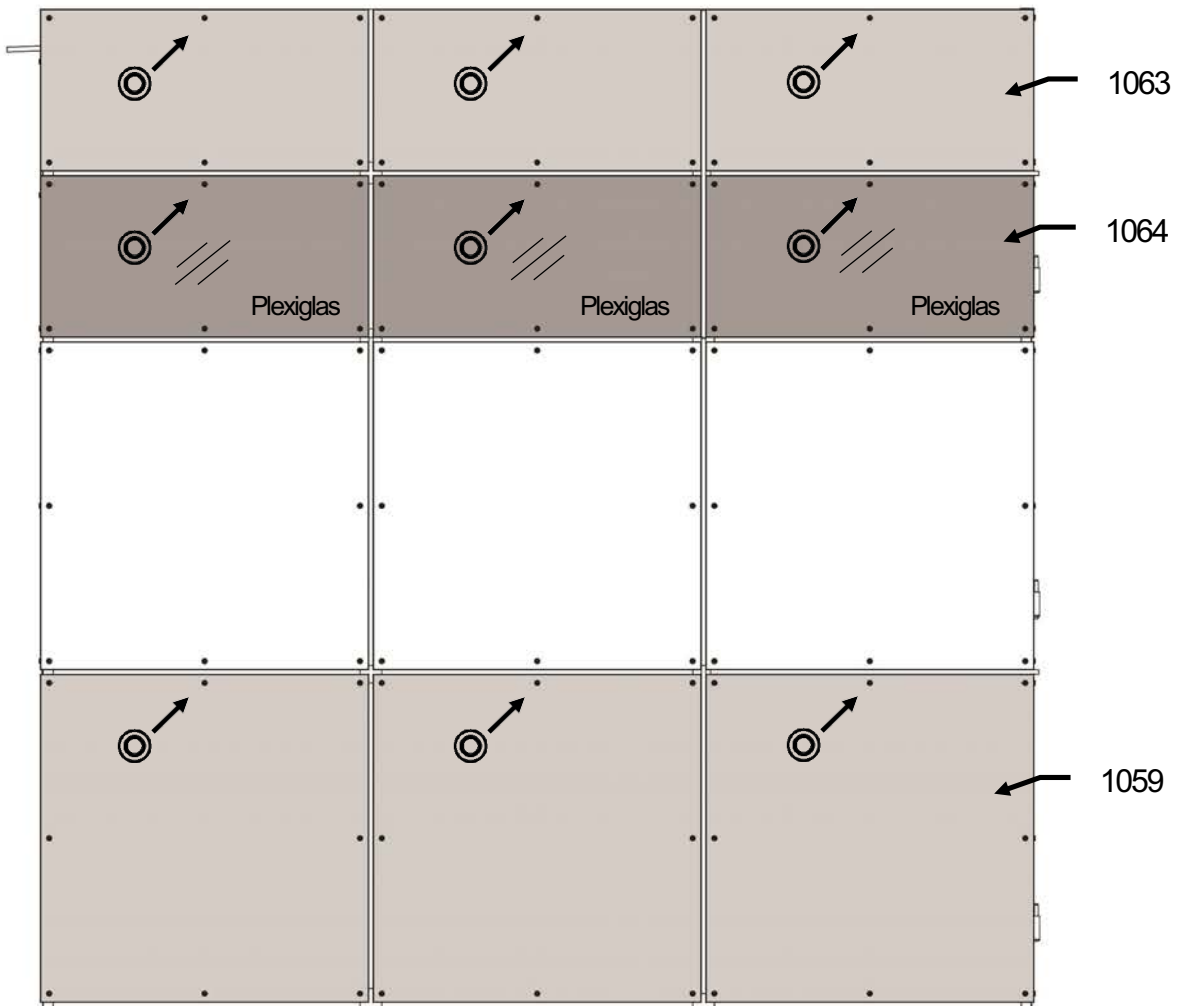
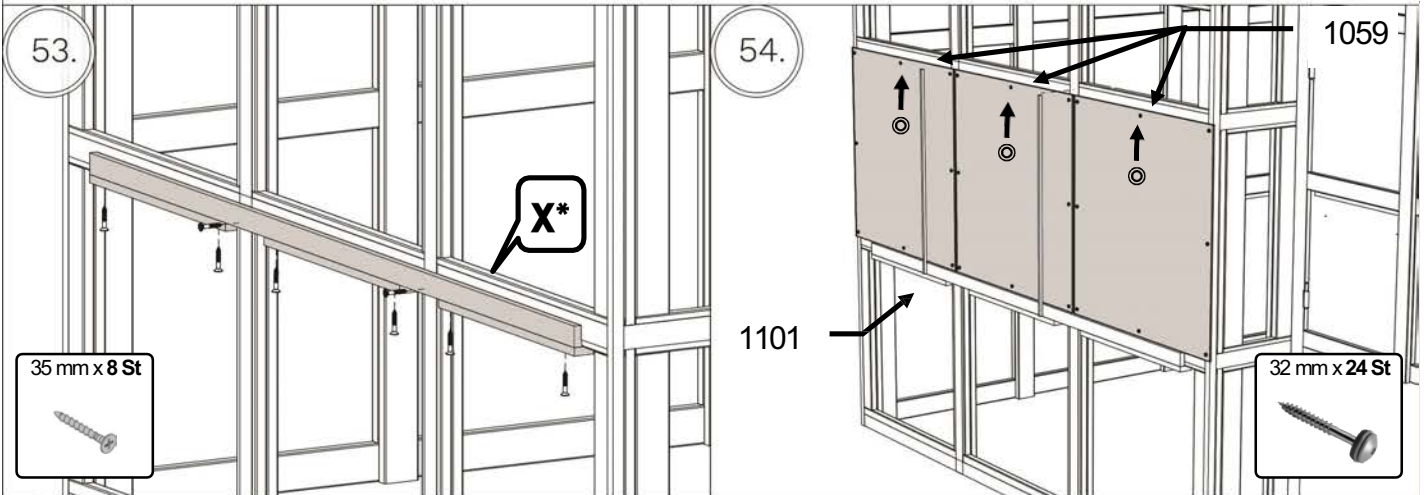

HPL 2

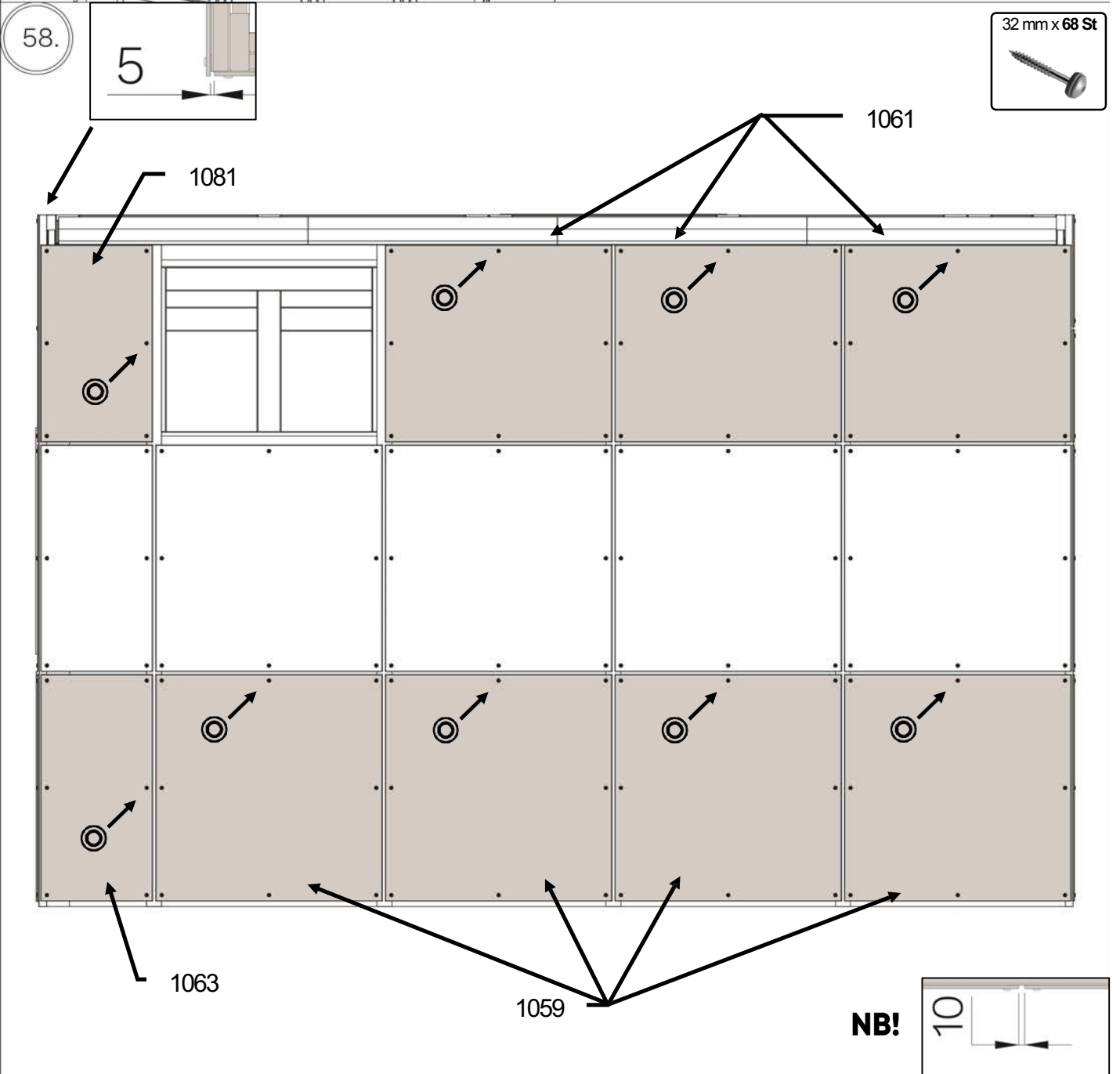
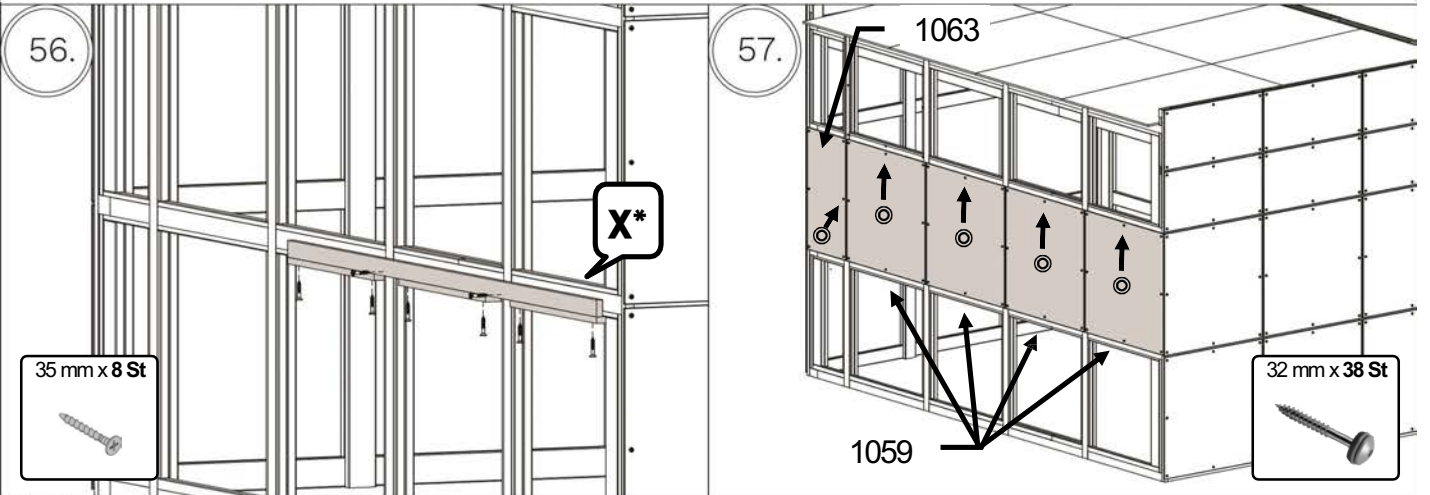

HPL 2

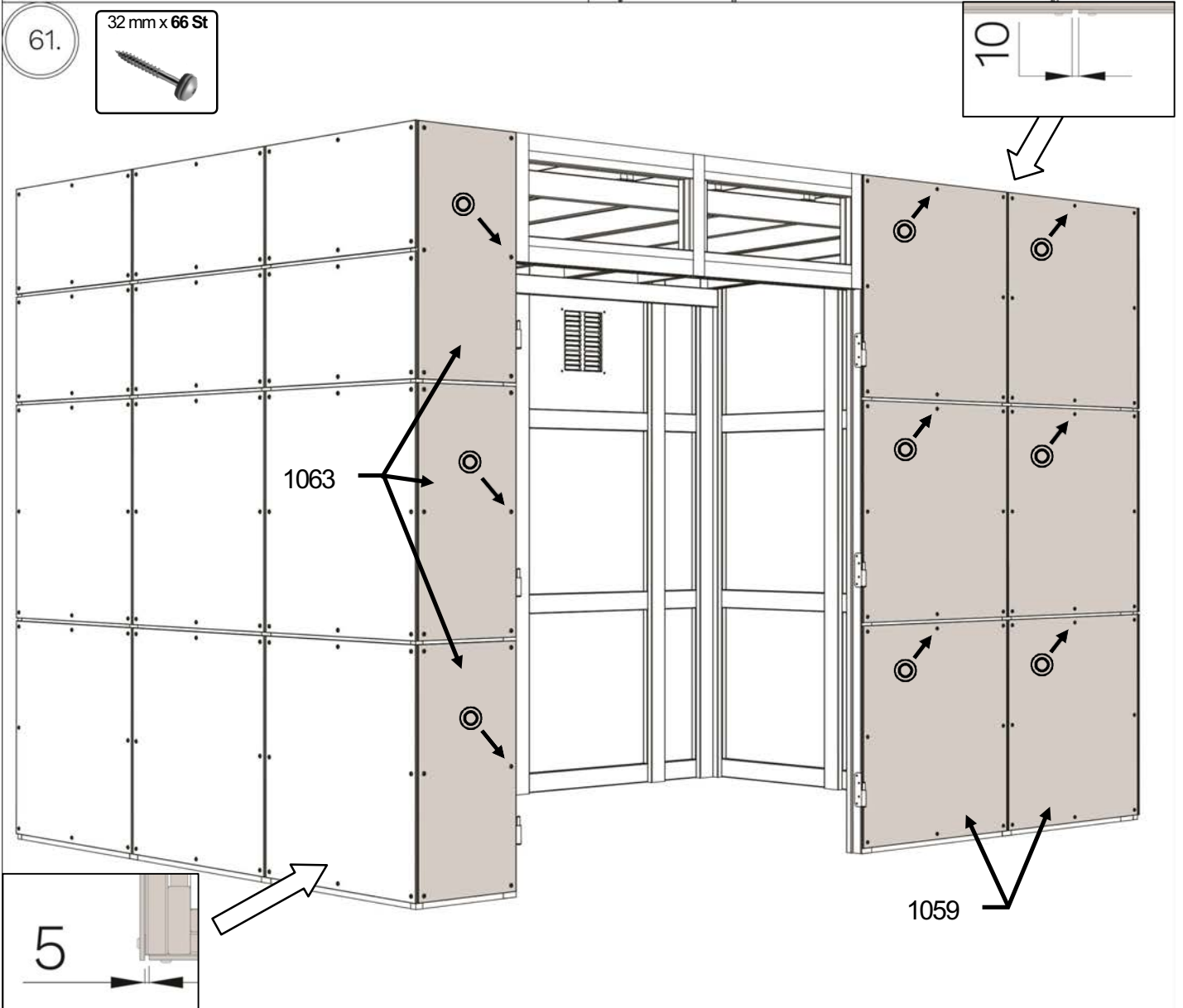
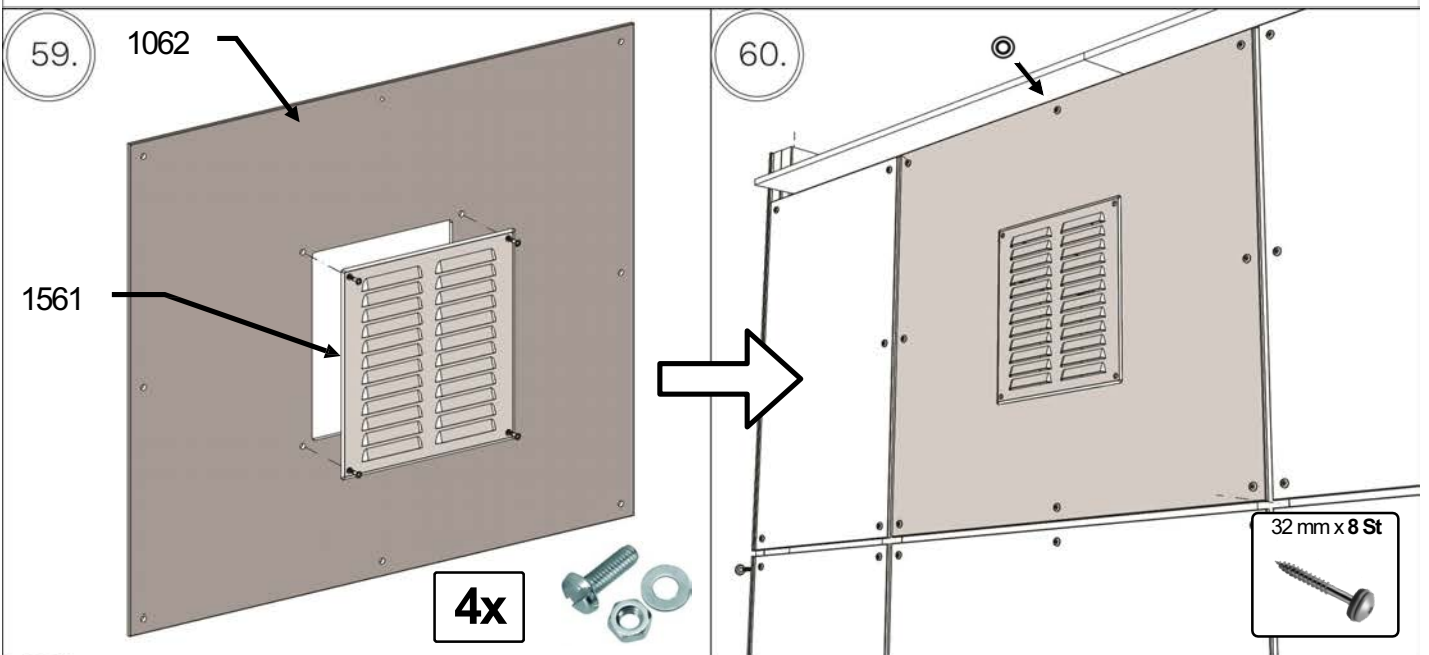

HPL 2

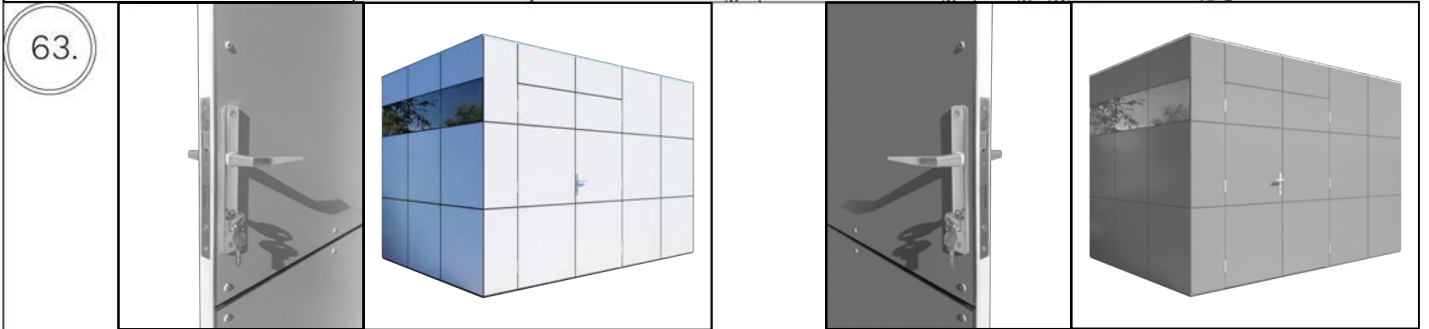
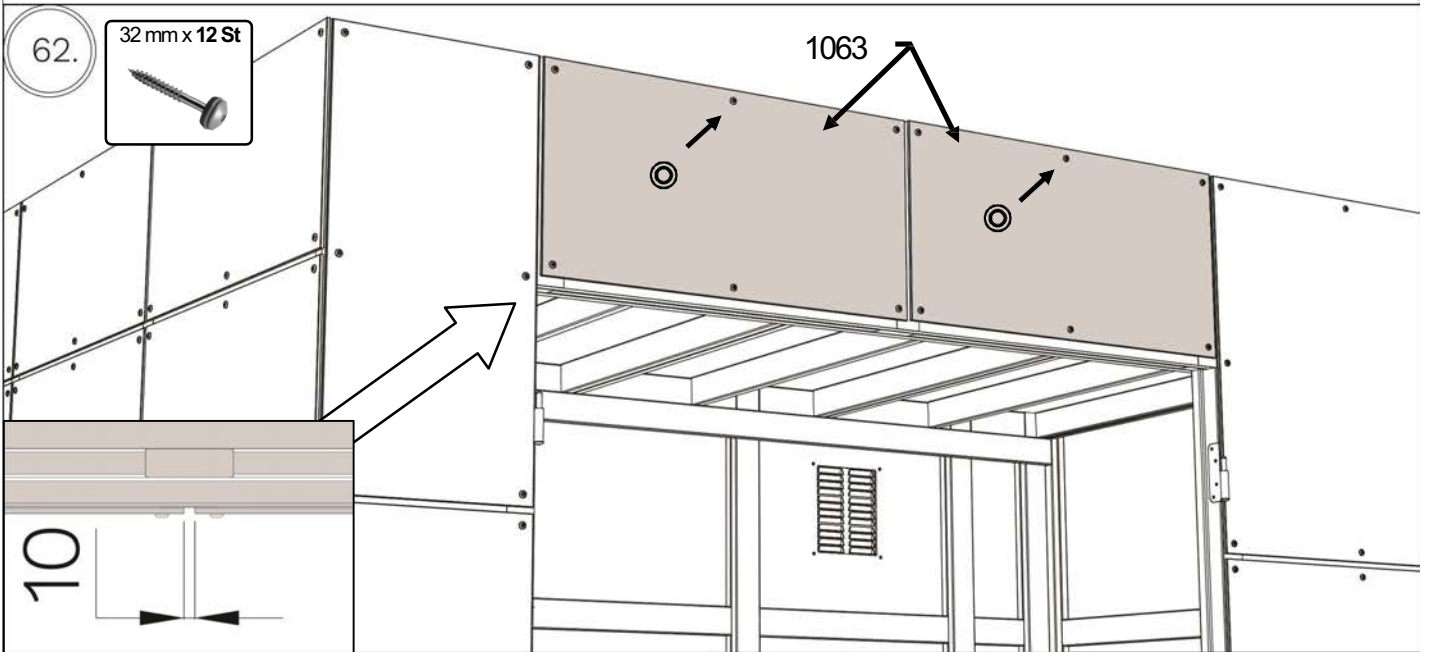

Silver Grey / Pure White

Anthracite Grey

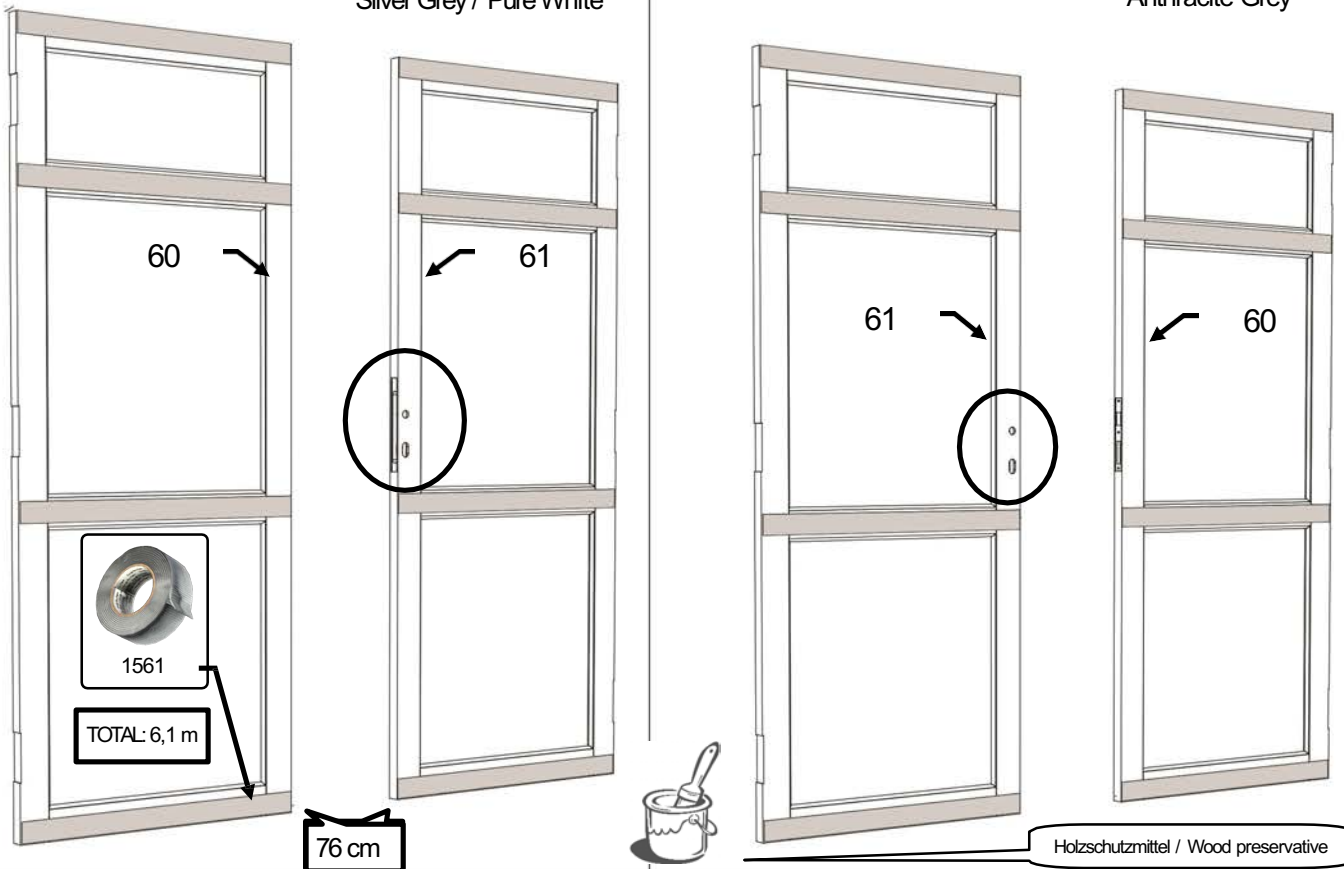

HPL 2

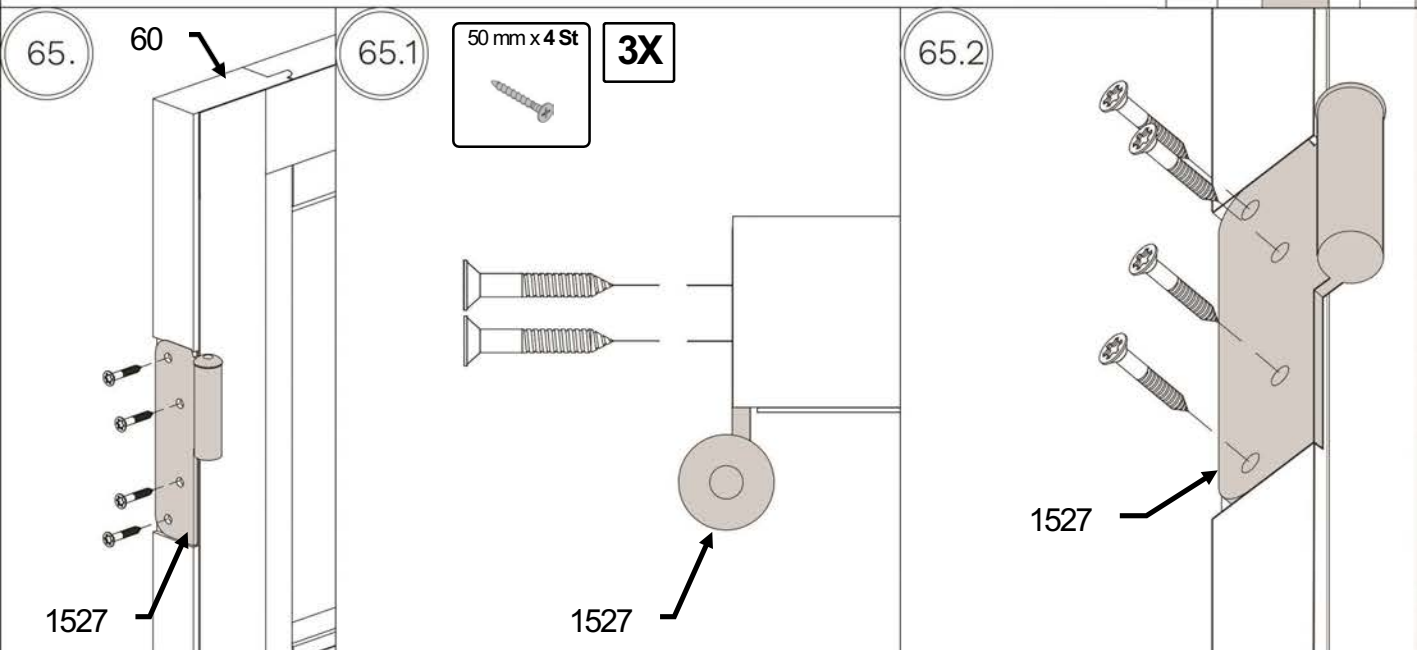
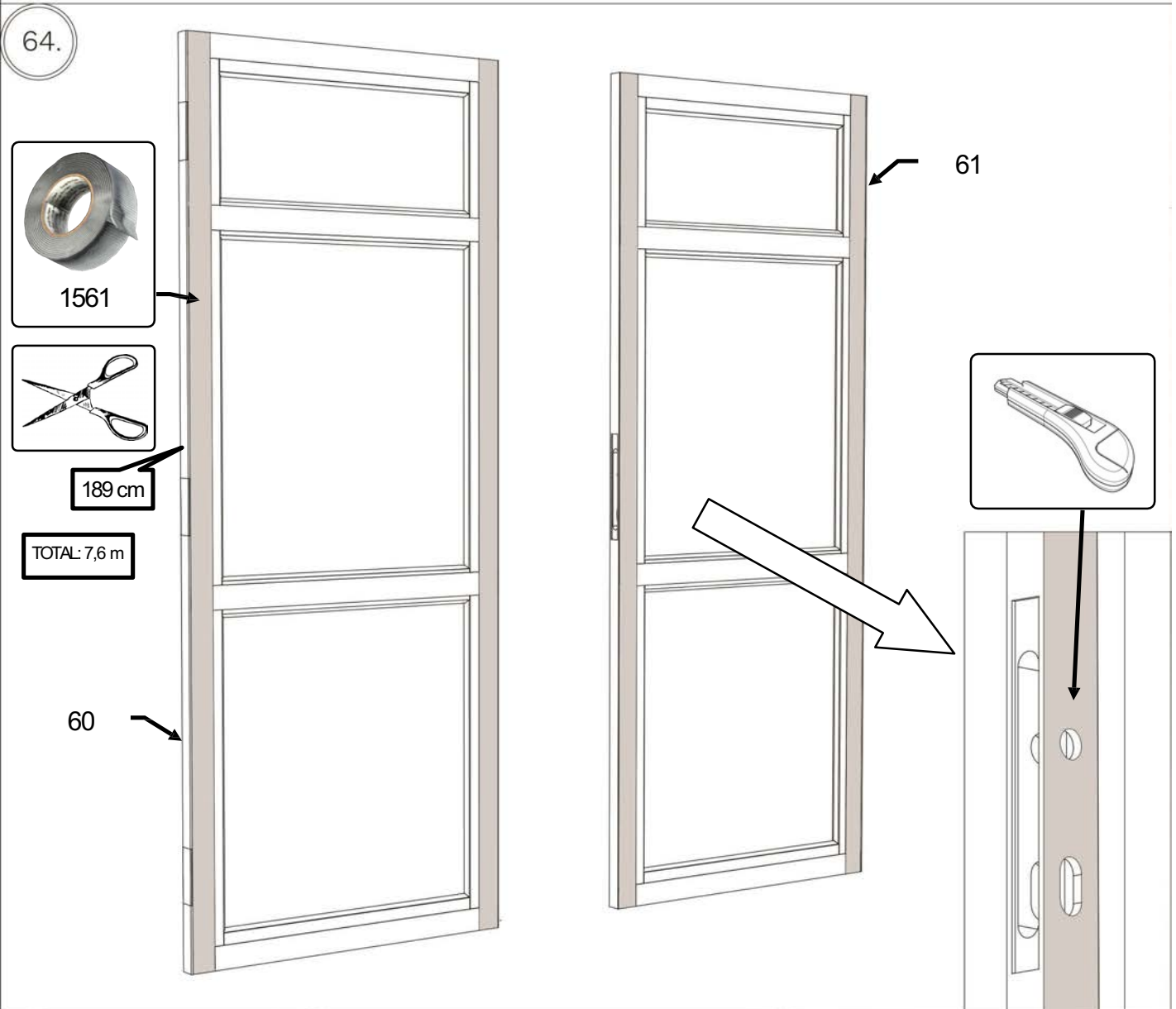

HPL 2

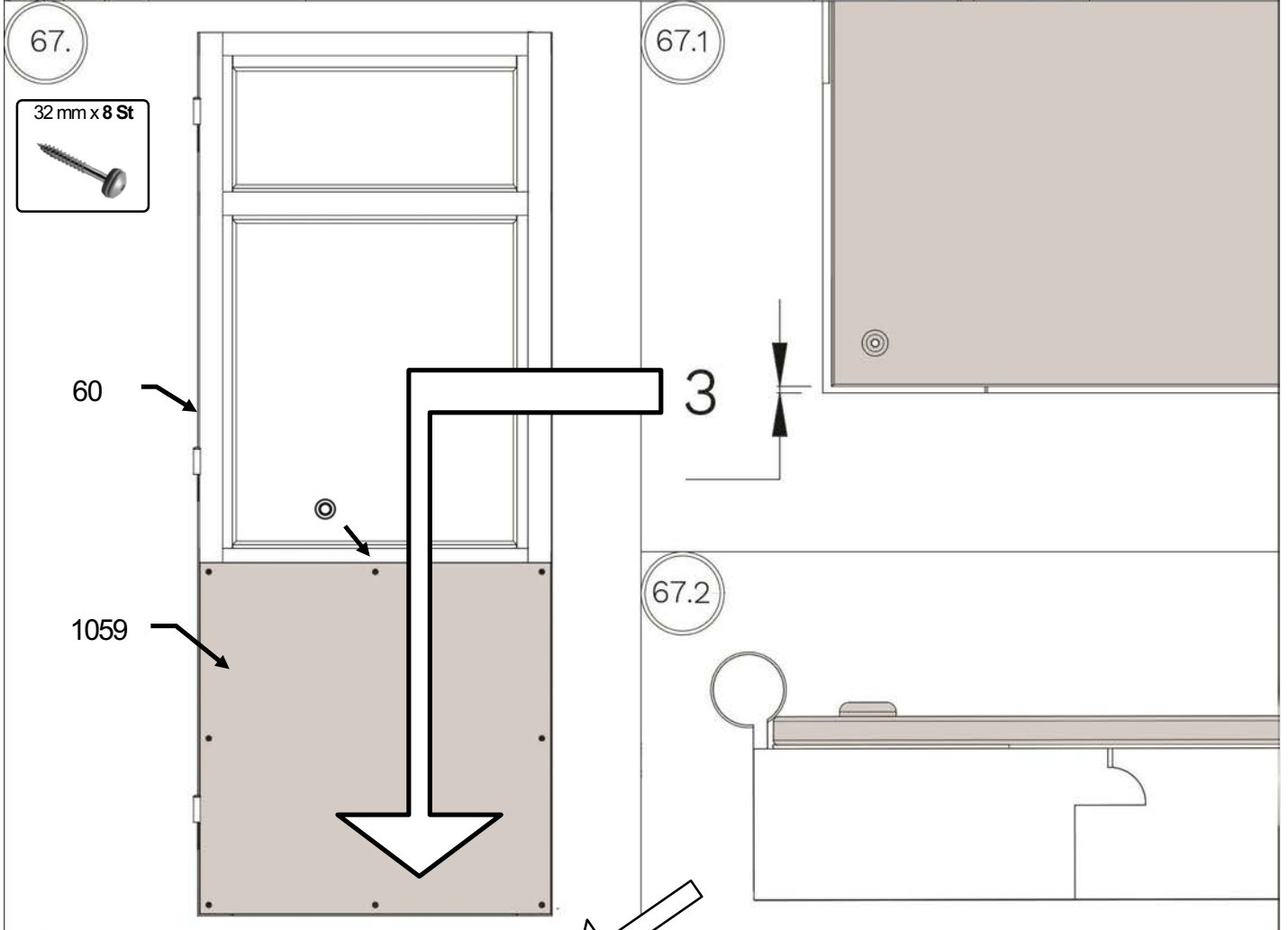
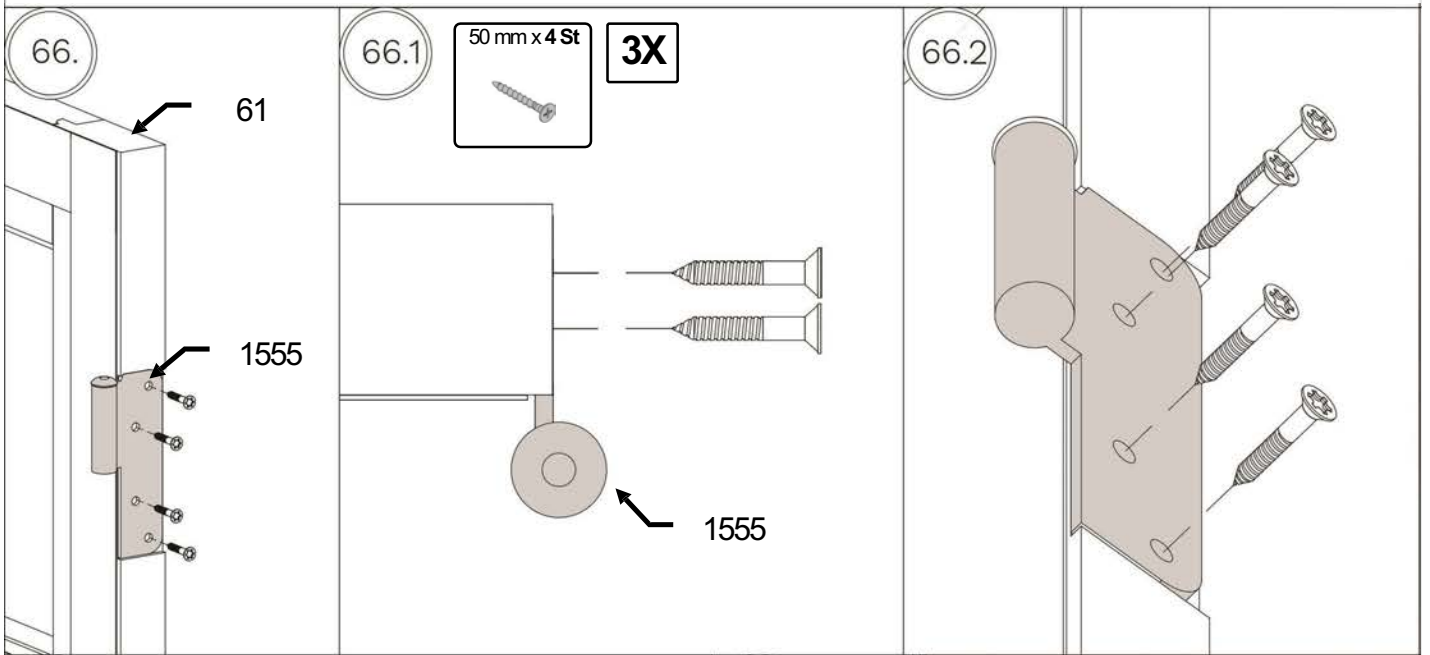

HPL 2

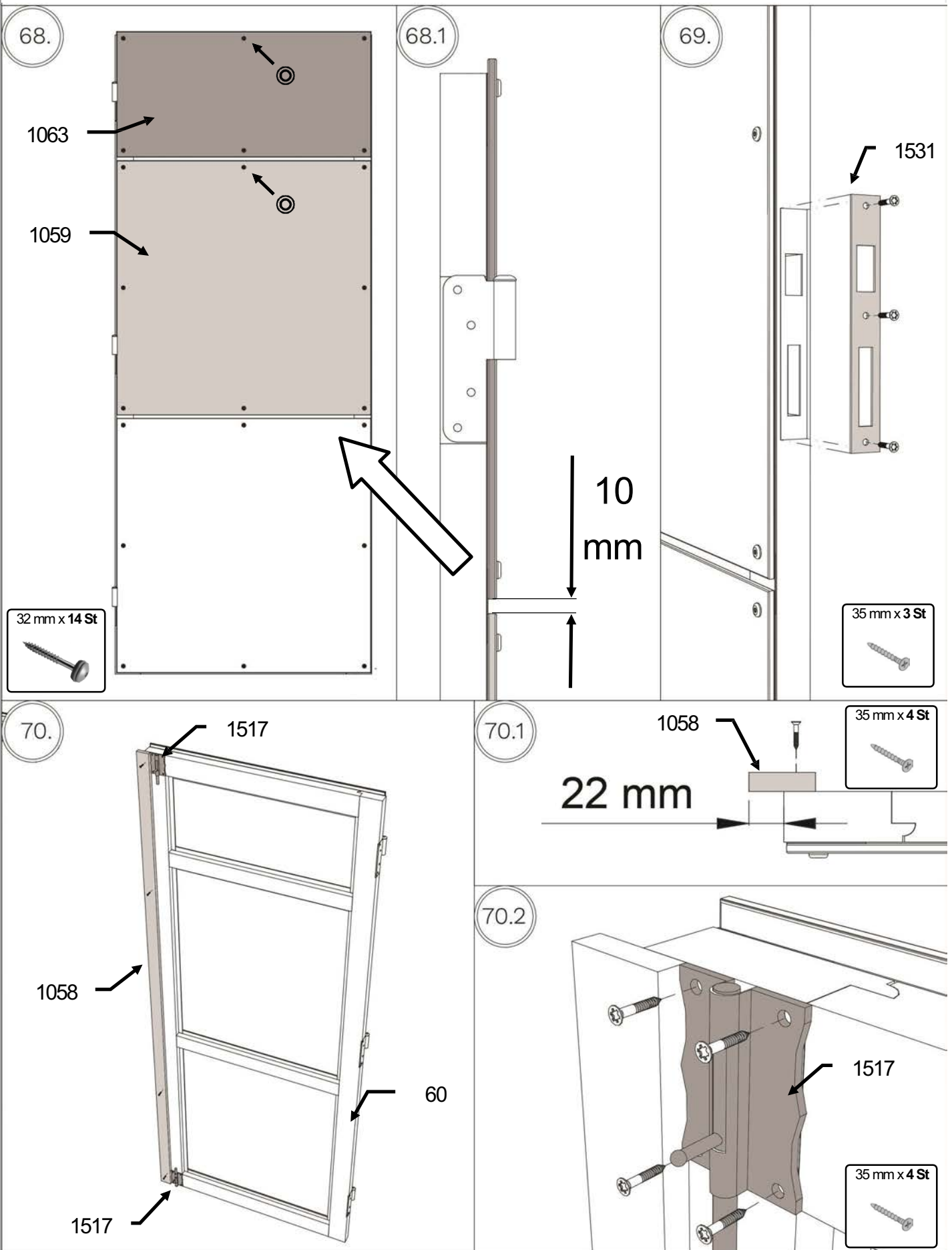

HPL 2

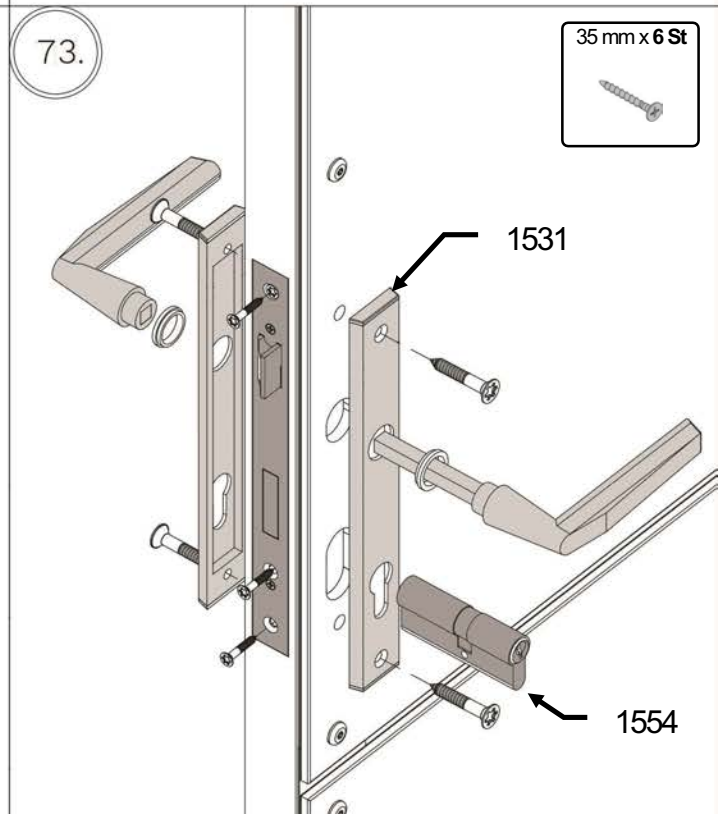
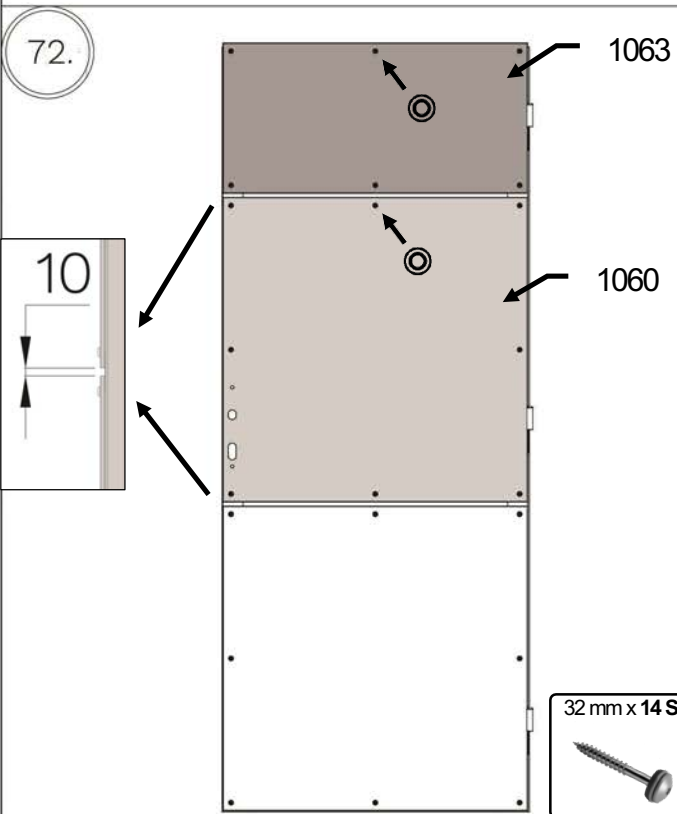
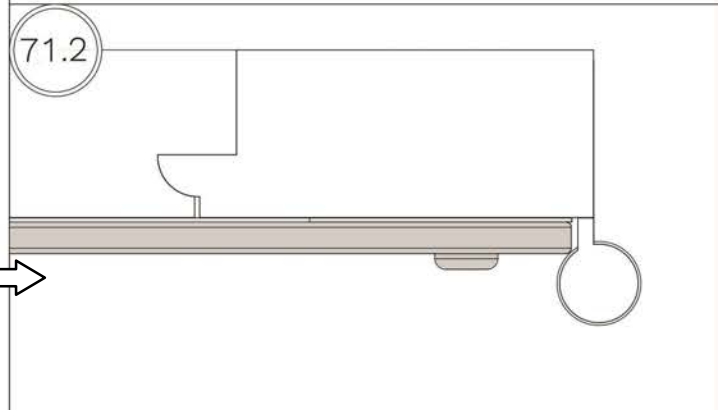
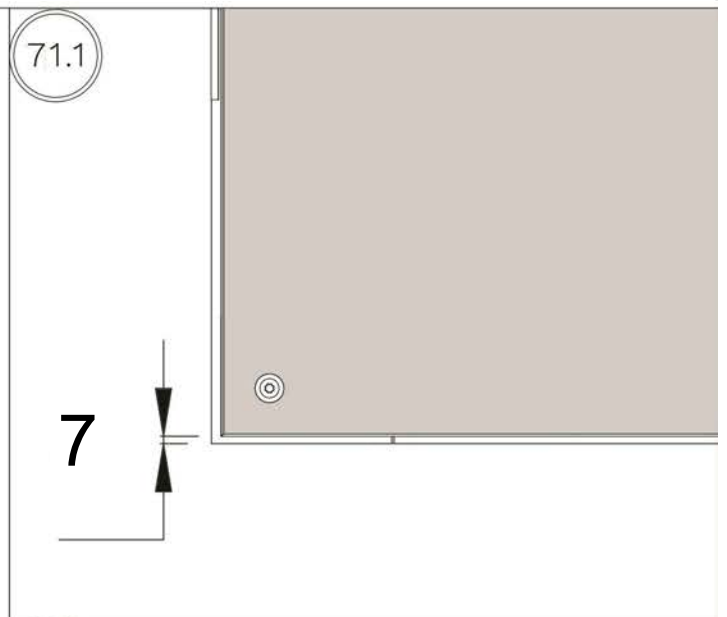
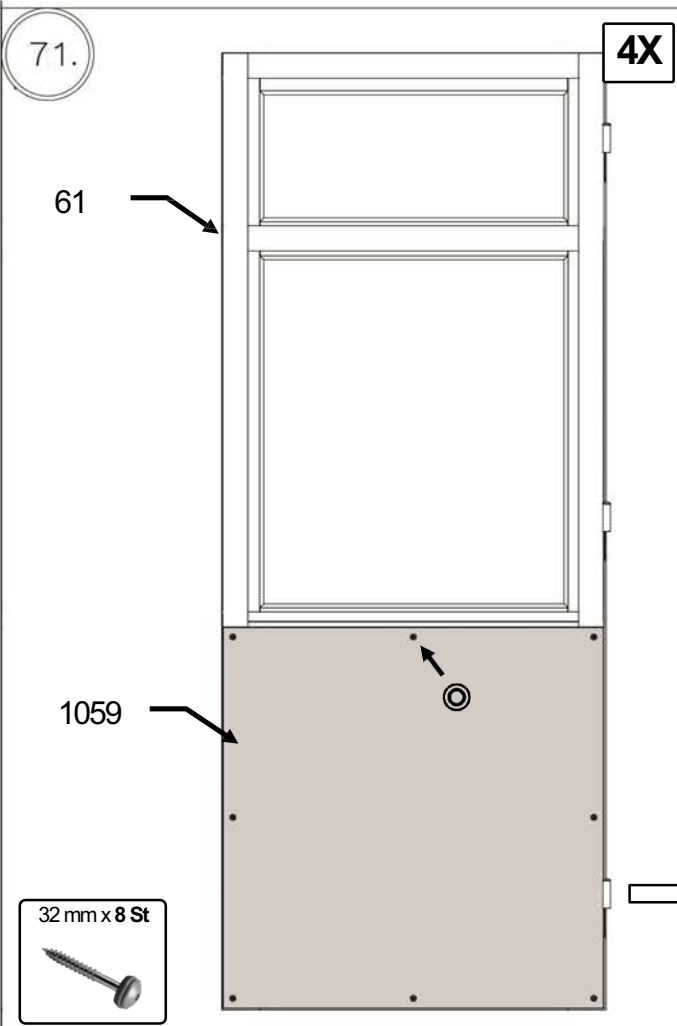

HPL 2

74.

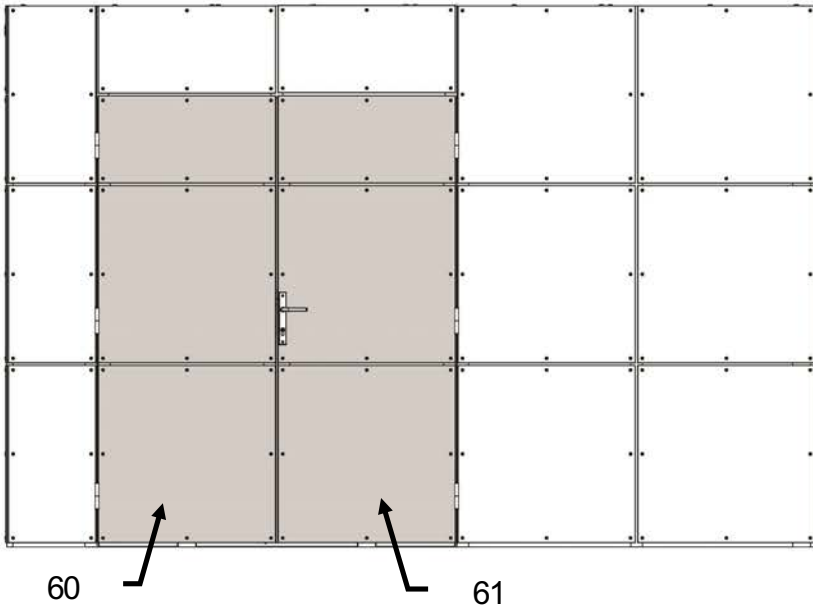

75.

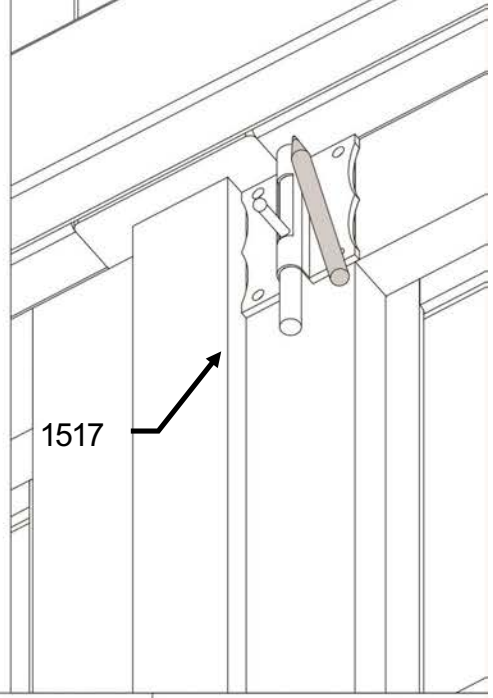
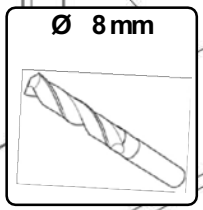

76.

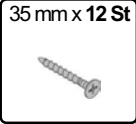
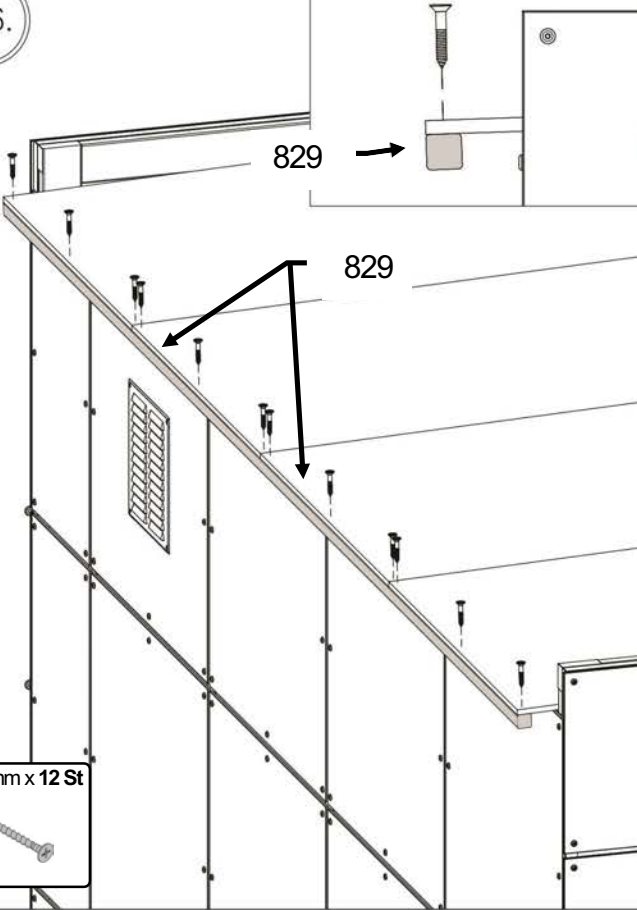

76.1

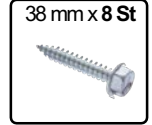
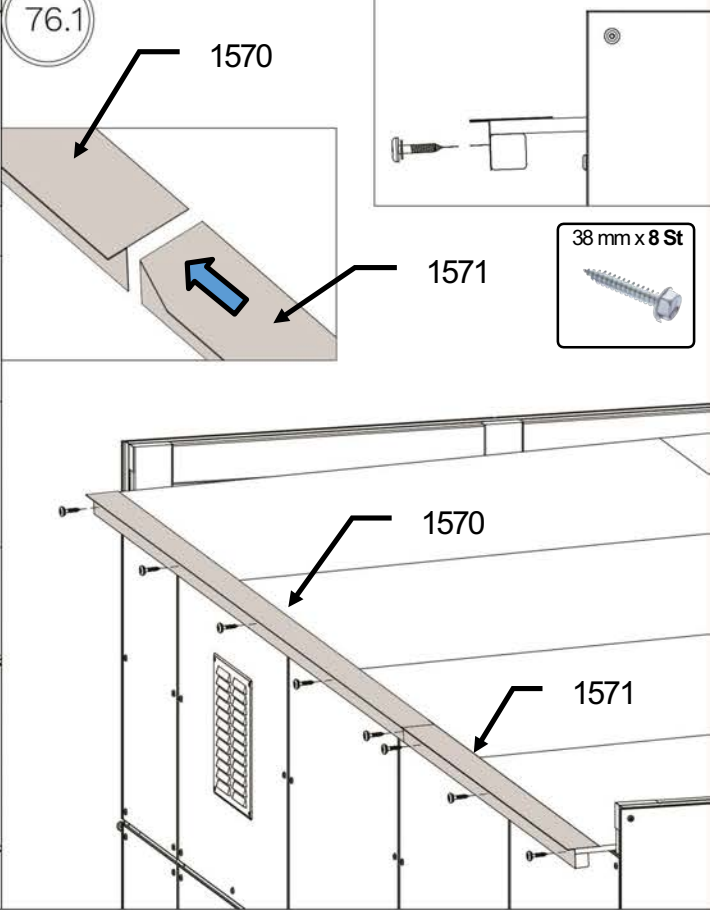

HPL 2

86.

* **Nicht im Lieferumfang enthalten / Not included!**

* **Dachbanen/ Roof membranes!**

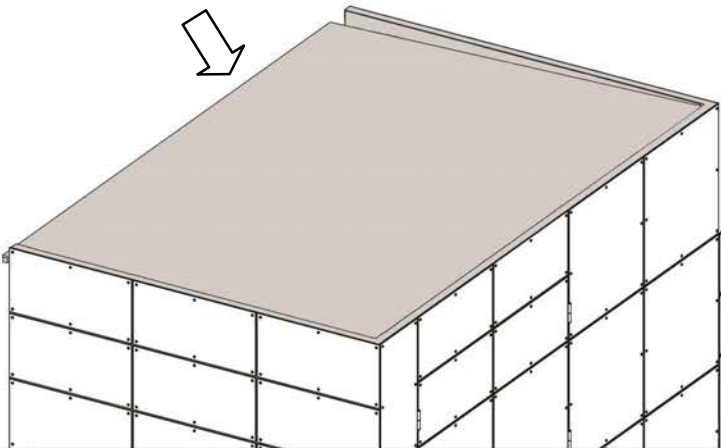

77.1

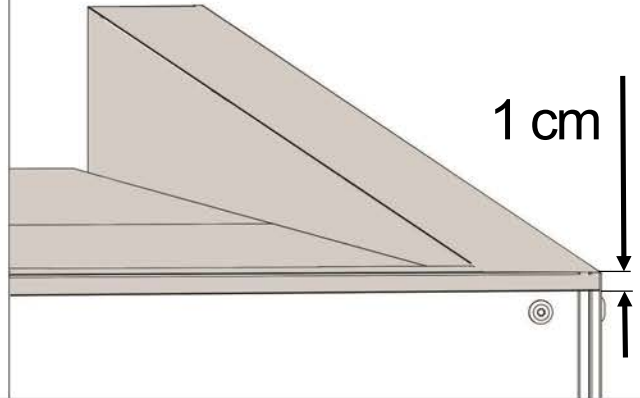

87.

38 mm x 21 St

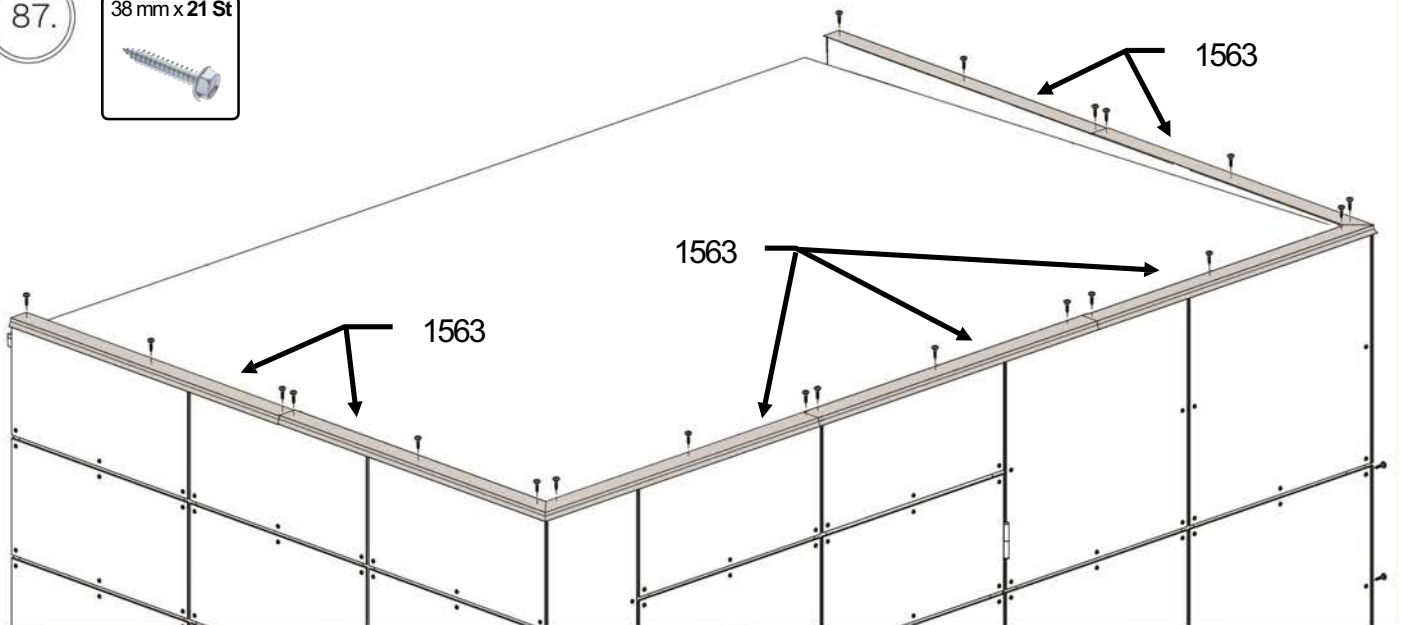

78.1

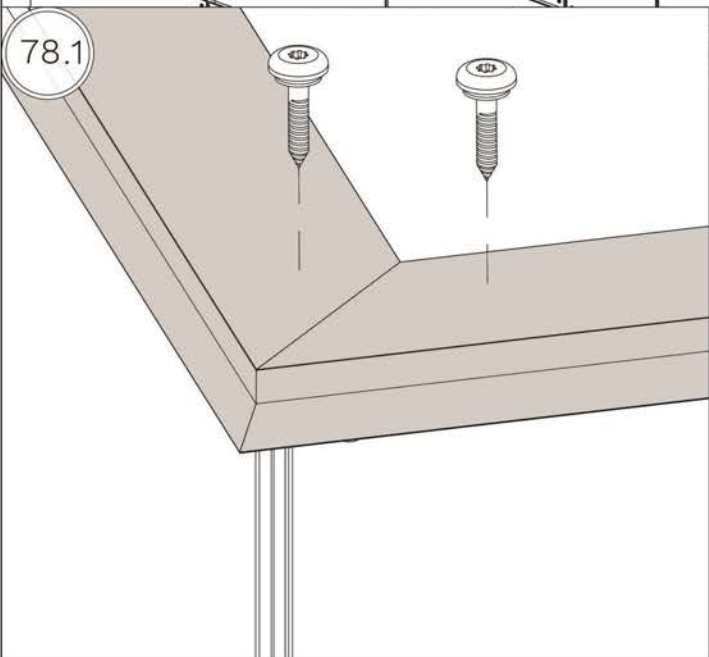

78.2

