

ASSEMBLY INSTRUCTION /
MONTAGEANLEITUNG

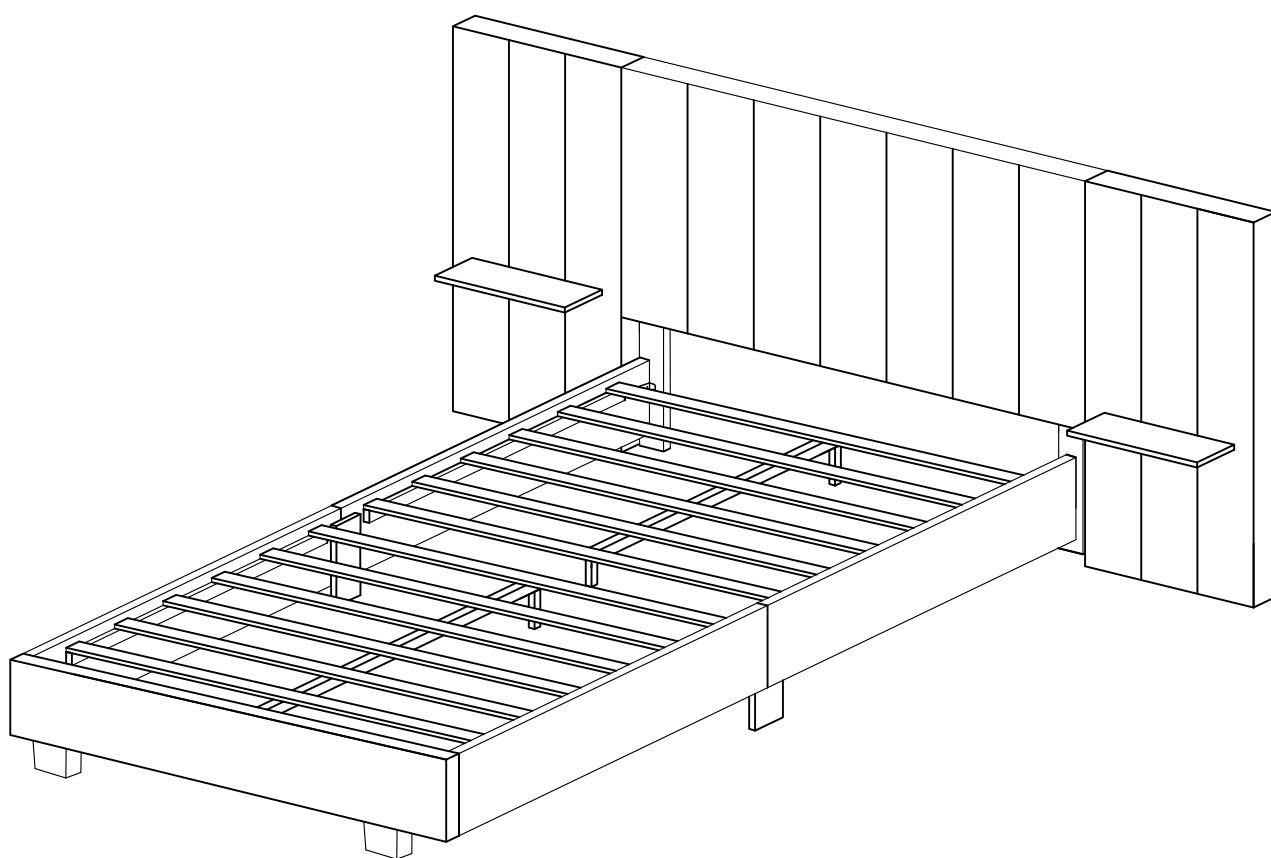

SKU CODE : WF323129 / WF323130

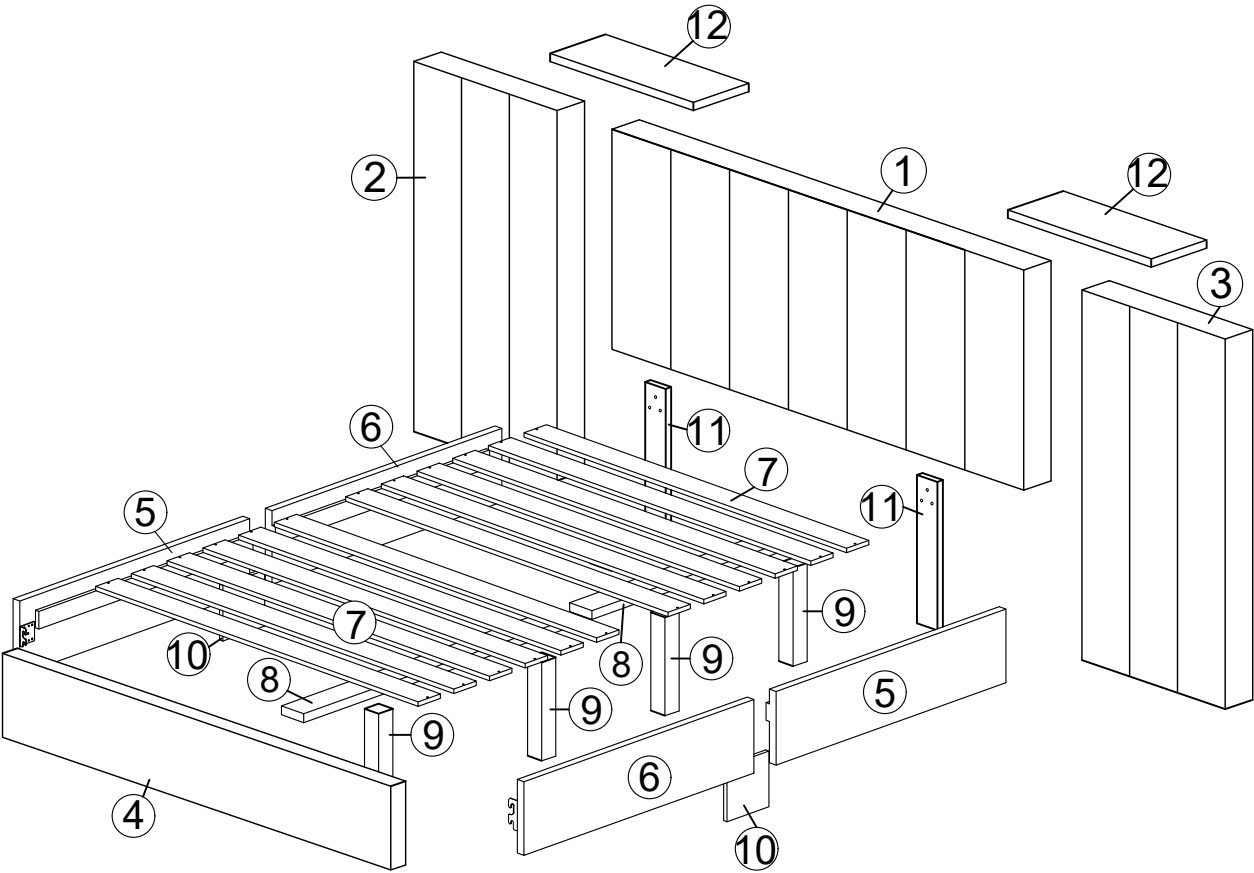

Details / Einzelheiten :

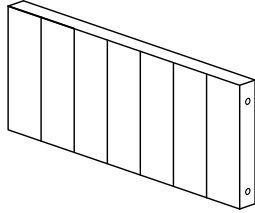
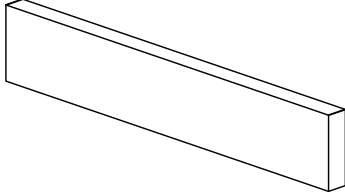
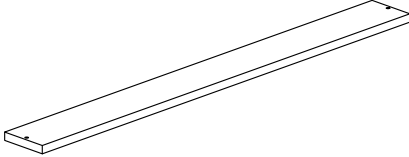
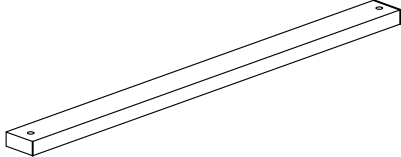

Part List / Stückliste (WF323129)

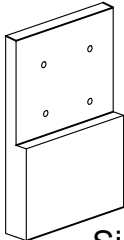
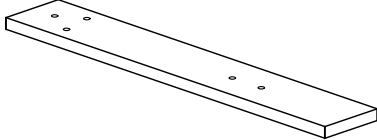
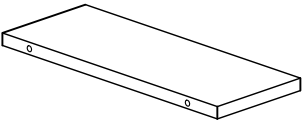
| | |
|--|--|
| <p>① x1</p>  <p>Head Board / Köpftteil</p> | <p>④ x1</p>  <p>Foot Board / Fußteil</p> |
| <p>⑦ x12</p>  <p>LVL Slats / Lamellen aus LVL</p> | <p>⑧ x2</p>  <p>Center Slats / Mittellatten</p> |
| <p>⑨ x4</p>  <p>Center Legs / Zentrale Beine</p> | <p>⑩ x2</p>  <p>Side Support Legs / Seitliche Stützbeine</p> |
| <p>⑪ x2</p>  <p>Headboard Support Legs / Köpftteil-Stützbeine</p> | <p>⑫ x2</p>  <p>Shelf / Regal</p> |

Part List / Stückliste (WF323130)

② x1

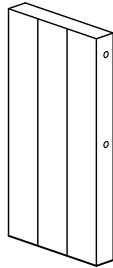

Wings Bed / Flügelbett

③ x1

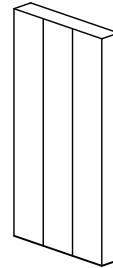

Wings Bed / Flügelbett

⑤ x2

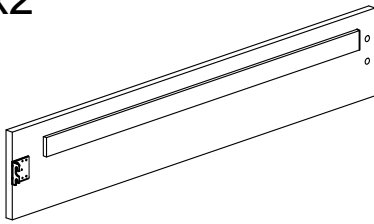





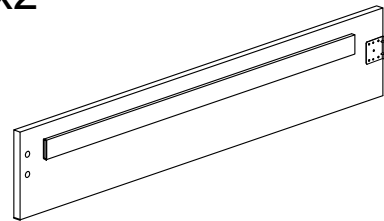



Side Rail / Seitenschiene

⑥ x2

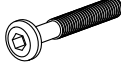
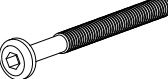

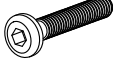
Side Rail / Seitenschiene

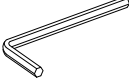
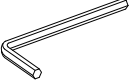
Part List / Stückliste (WF323130)

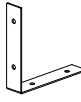
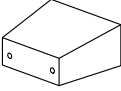
| No | OUTLOOK / AUSBLICK | DESC / BESCHR | QTY |
|-----|---|--|-----|
| (A) |  | M4x28mm Screw / <i>Schraube</i> | 24 |
| (B) |  | M4x20mm Screw / <i>Schraube</i> | 8 |
| (C) |  | JCBC M6x30mm | 18 |
| (D) |  | JCBC M6x45mm | 4 |
| (E) |  | JCBC M6x50mm | 4 |
| (F) |  | JCCA M6x50mm | 4 |
| (G) |  | JCBB M8x20mm | 8 |
| (H) |  | Barrel Nut / <i>Zylindermutter</i> | 4 |
| (I) |  | L Key M4 x 100mm / <i>L Schlüssel</i> | 1 |
| (J) |  | L Key M5 x 70mm / <i>L Schlüssel</i> | 1 |
| (K) |  | Flat Washer M6x19 / <i>Flache Unterlegscheibe</i> | 22 |
| (L) |  | L Bracket / <i>L-Halterung</i> | 2 |
| (M) |  | Plastic Legs / <i>Kunststoffbeine</i> | 2 |

ASSEMBLY TOOLS REQUIRED (NOT INCLUDED) / ERFORDERLICHE MONTAGEWERKZEUGE (NICHT ENTHALTEN)



STEP 1 / SCHRITT 1 :

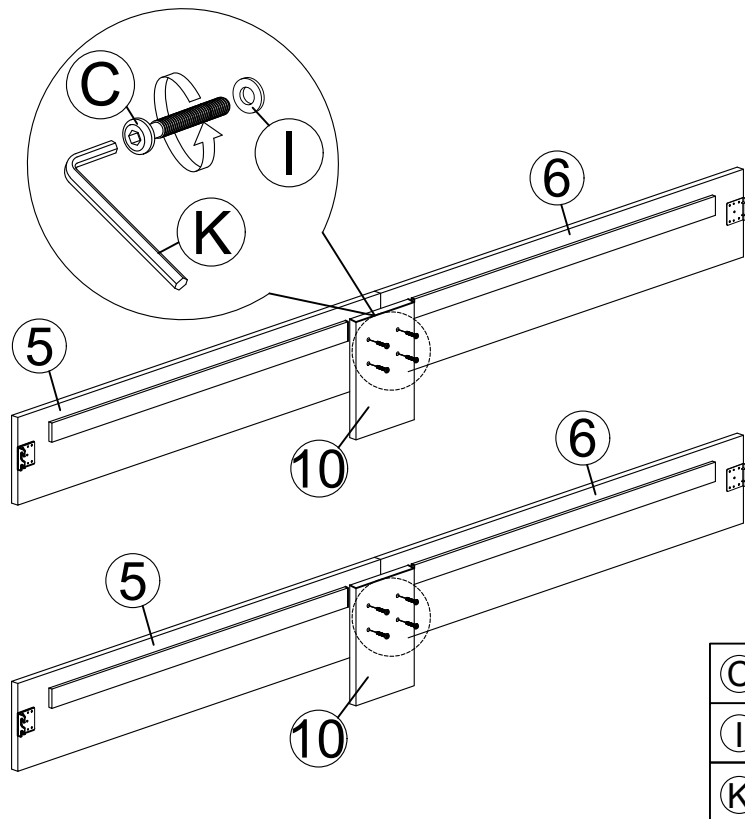

STEP 2 / SCHRITT 2 :

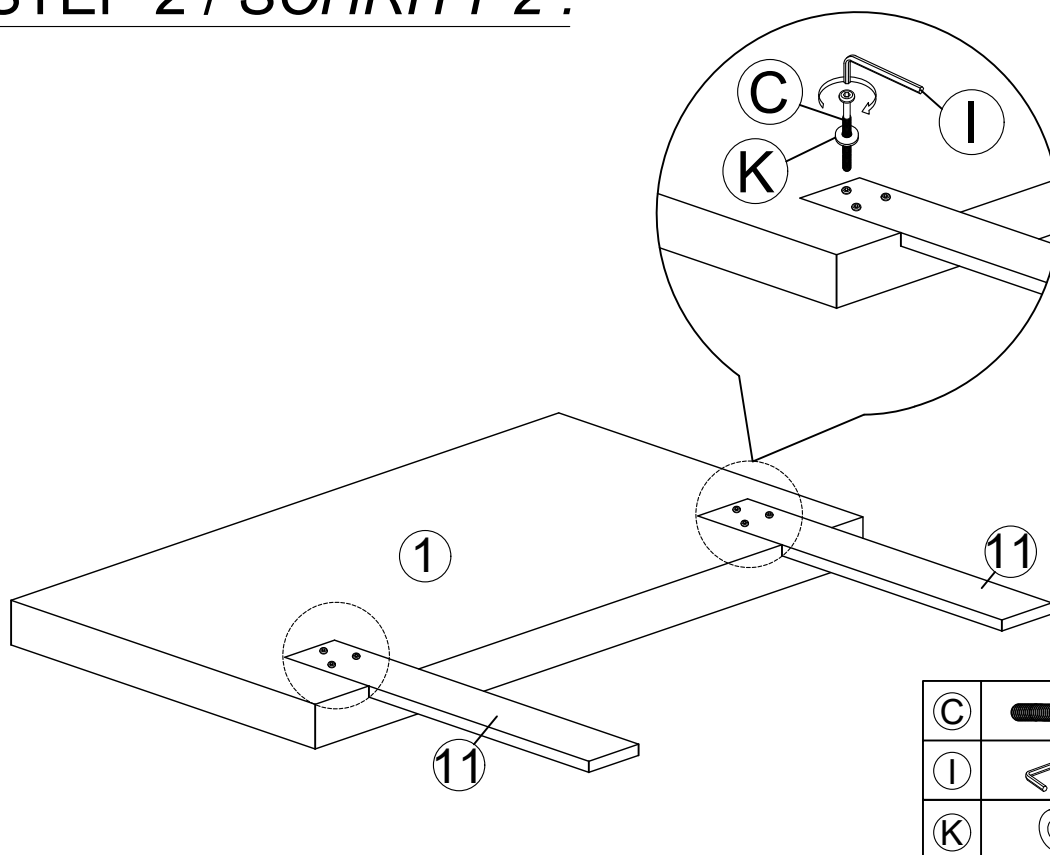

STEP 3 / SCHRITT 3 :

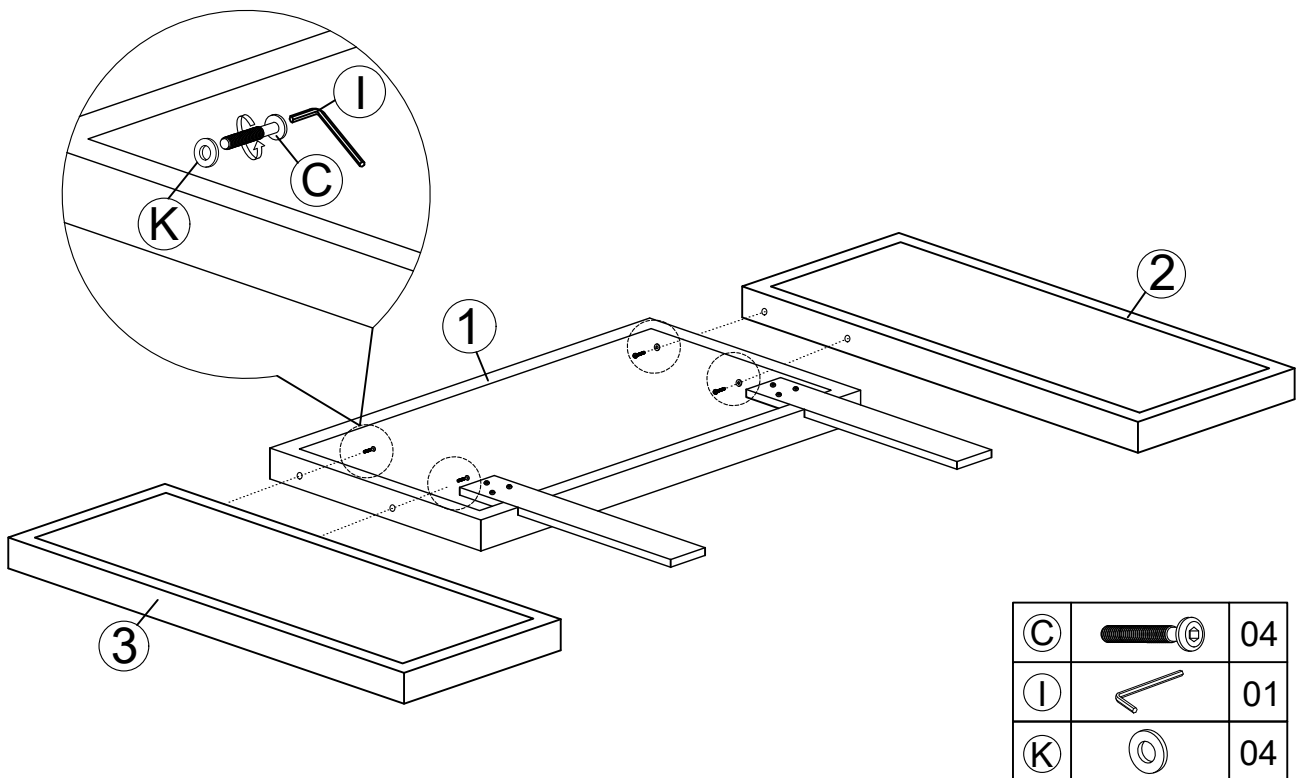

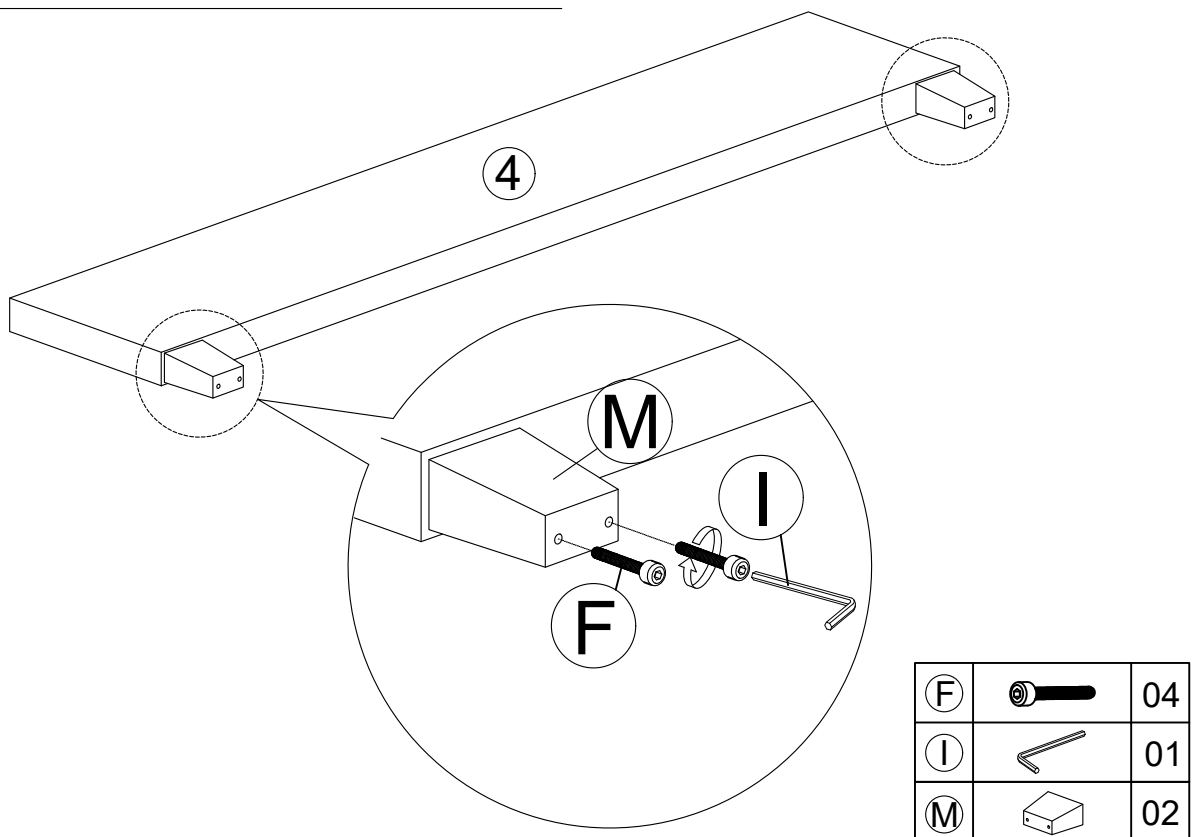

STEP 4 / SCHRITT 4 :



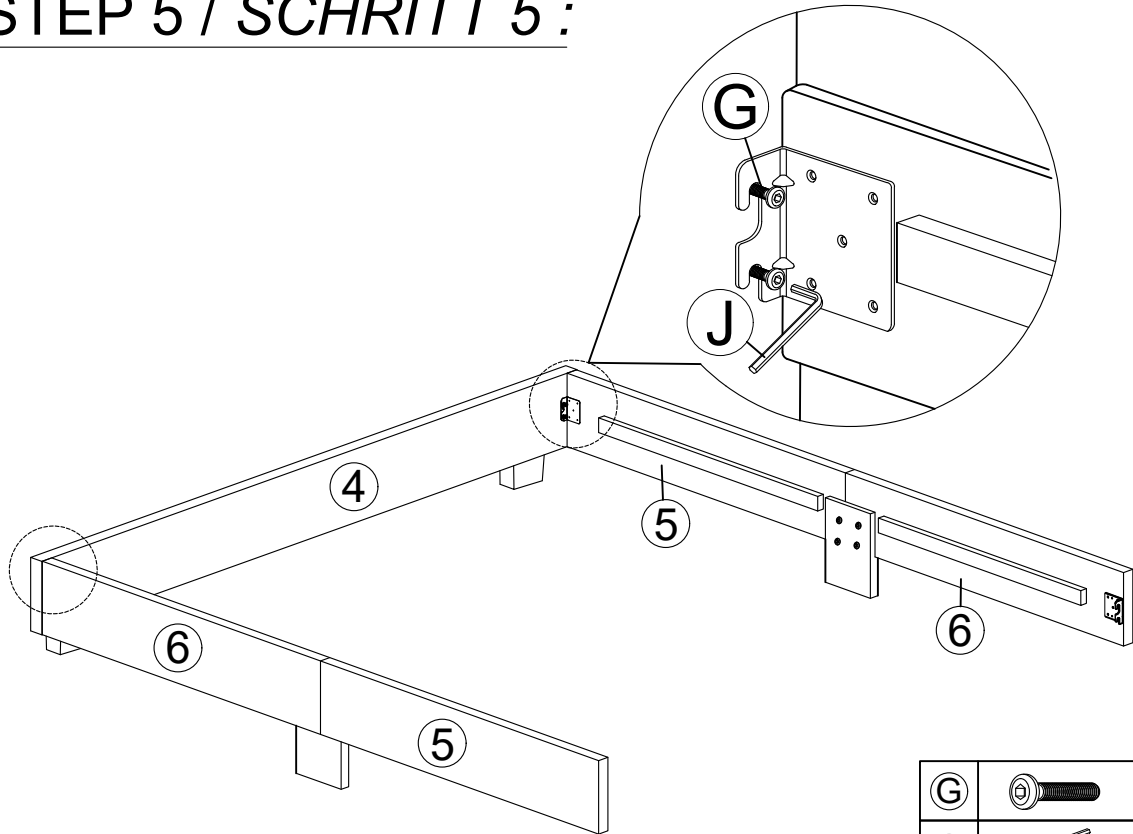

STEP 5 / SCHRITT 5 :

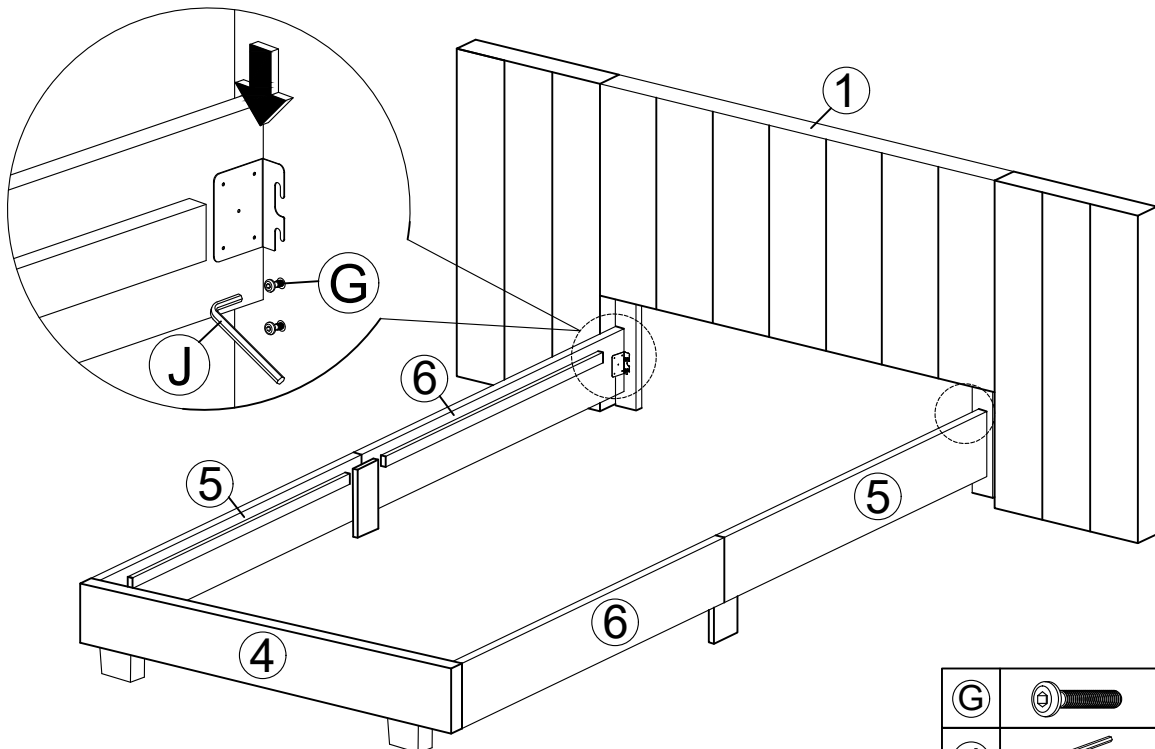

| | | |
|---|---|----|
| G |  | 04 |
| J |  | 01 |

STEP 6 / SCHRITT 6 :



| | | |
|---|---|----|
| G |  | 04 |
| J |  | 01 |

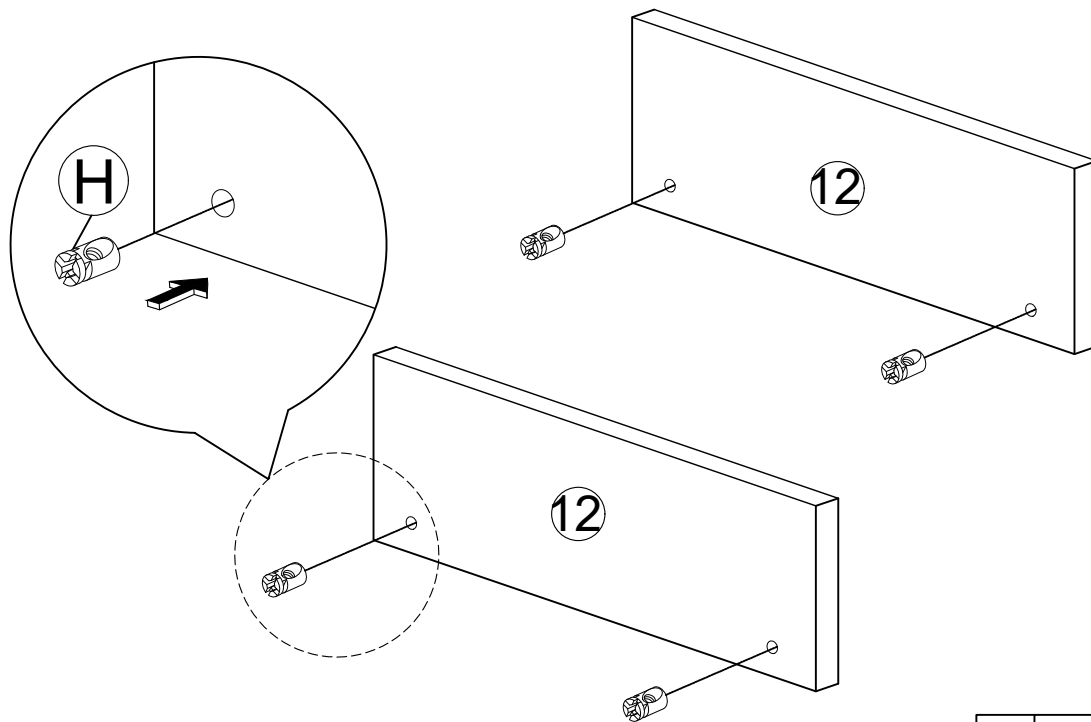

STEP 7 / SCHRITT 7 :

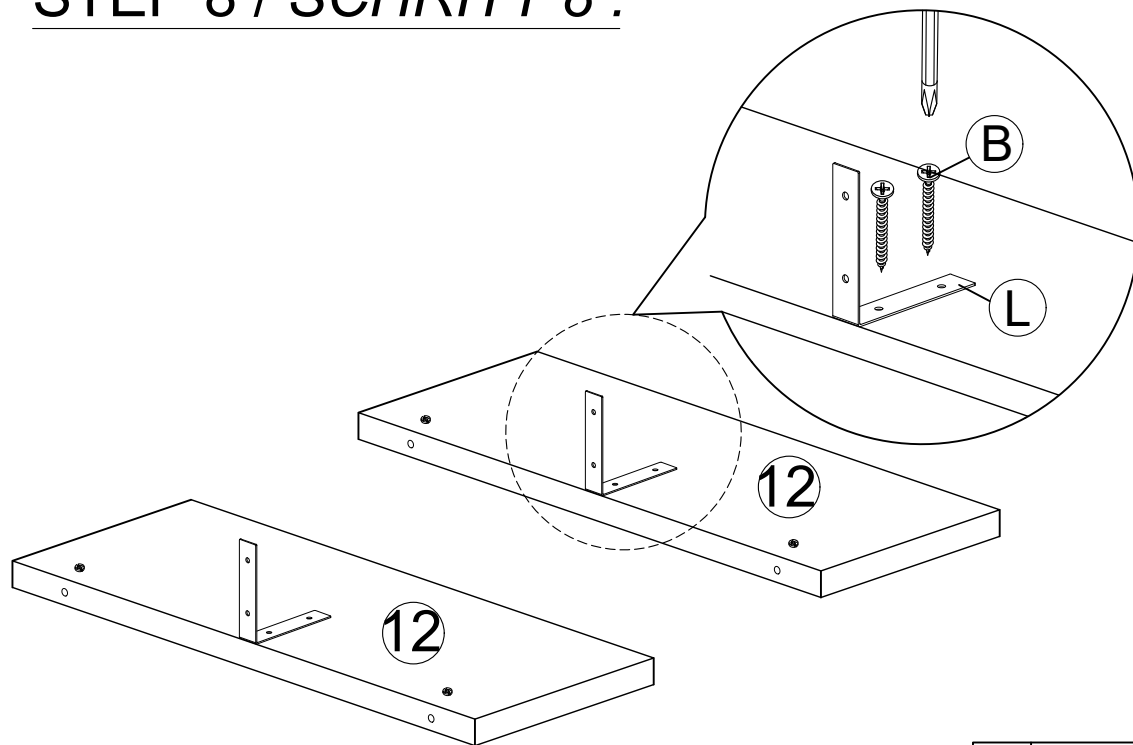

| | | |
|-----|---|----|
| (H) |  | 04 |
|-----|---|----|

STEP 8 / SCHRITT 8 :



| | | |
|-----|---|----|
| (B) |  | 04 |
| (L) |  | 02 |

STEP 9 / SCHRITT 9 :

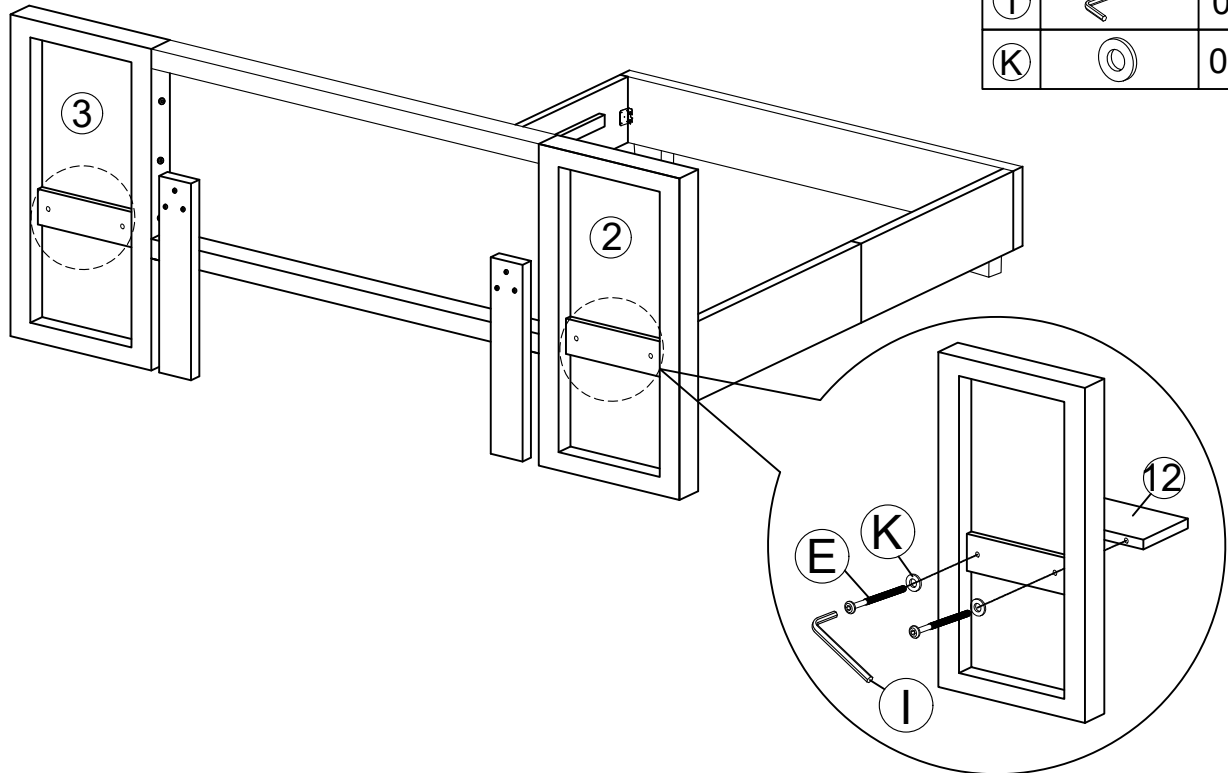

| | | |
|-----|--|----|
| (E) | | 04 |
| (I) | | 01 |
| (K) | | 04 |

STEP 10 / SCHRITT 10 :

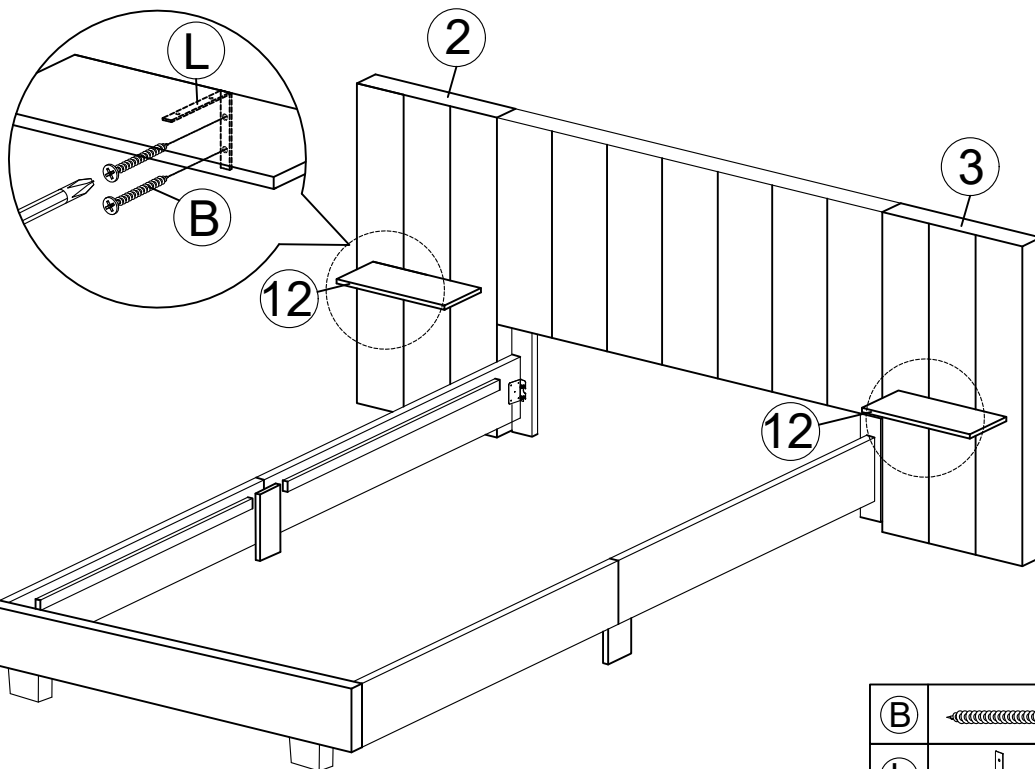

| | | |
|-----|--|----|
| (B) | | 04 |
| (L) | | 02 |

STEP 11 / SCHRITT 11 :

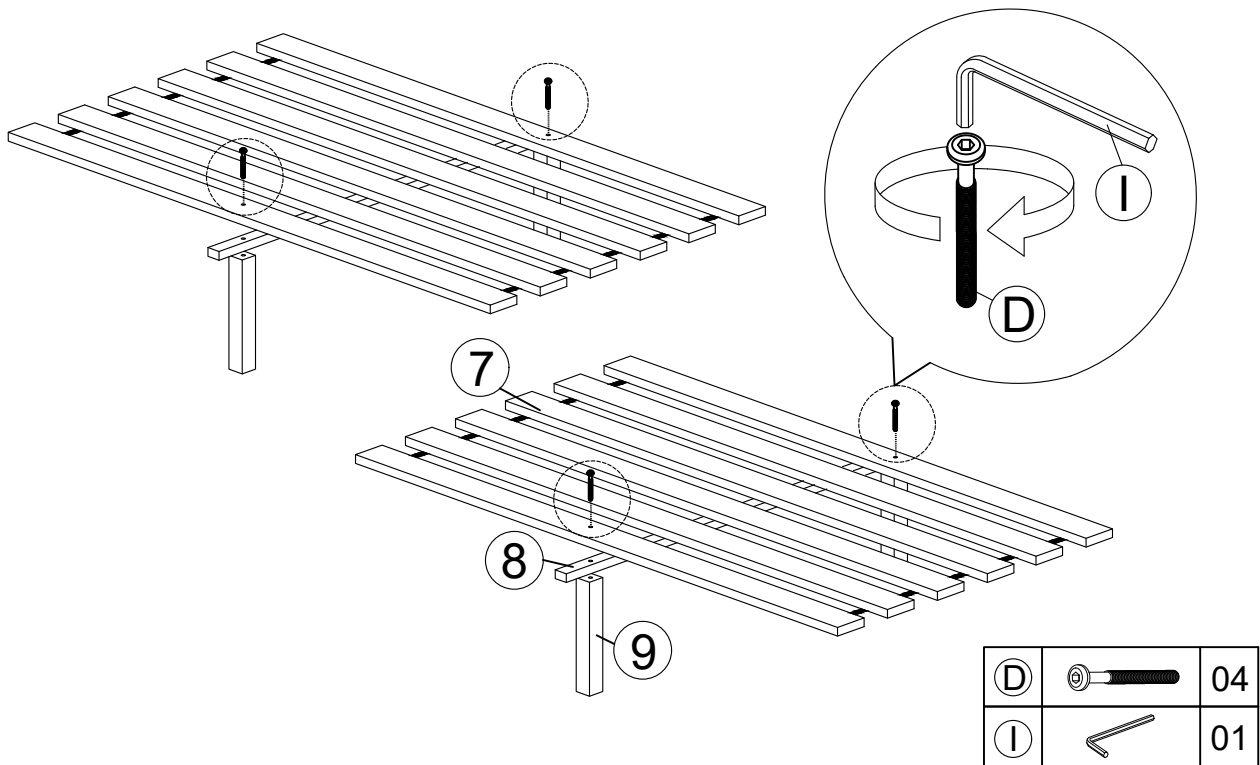

STEP 12 / SCHRITT 12 :

