

Flexispot Limited Warranty

This limited warranty offered by Flexispot covers defects in material or workmanship in new Flexispot products. This warranty extends to the original purchaser only and is non-transferable. Only consumers purchasing Flexispot products from authorized Flexispot retailers or resellers may benefit from our limited warranty.

What is Covered?

The Flexispot limited warranty covers our products against defects in material or workmanship as follows:

- Flexispot Height Adjustable Desk Frames

All height – adjustable desks purchased on or after October 5, 2016 include a 5-year warranty for the frame, and a 3-year warranty for the motor, controller, switch and other mechanisms.

- Flexispot Sit-Stand Desktop Workstations

All standing desks purchased on or after October 5, 2016 include a 5-year warranty for the frame and medium-fiber desktop, and a 3-year warranty for gas spring system and mechanisms.

- FlexiSpot Office Chairs

All desk chairs purchased on or after December 1, 2018 include a 3-year warranty for chair body, and other mechanisms.

What are your Remedies?

Flexispot will replace at no charge to the consumer the defective parts only or, at Flexispot's option, replace any product or part of the product that is defective because of improper workmanship and/or material, under normal installation, use, service and maintenance. If Flexispot is unable to provide a replacement and repair is not practical or cannot be completed in a timely fashion, Flexispot may elect to refund the purchase price in exchange for the return of the product. In the rare event that your Flexispot product is defective, we will provide you with a replacement item shipped at no cost to you within the continental United States. The shipping method for replacement products is FedEx Ground, but expedited shipping is available if you choose to pay the additional expense. In addition, you will need to pay the shipping costs if any products need to be shipped to you at an address outside the continental United States.

REPAIR OR REPLACEMENT (OR, IN LIMITED CIRCUMSTANCES, REFUND OF THE PURCHASE PRICE) AS PROVIDED UNDER THIS WARRANTY IS THE EXCLUSIVE REMEDY OF THE PURCHASER. FLEXISPOT NEITHER ASSUMES NOR AUTHORIZES ANY PERSON TO CREATE FOR IT ANY OTHER OBLIGATION OR LIABILITY IN CONNECTION WITH THIS PRODUCT.

What is Not Covered?

Our limited warranty does not cover any problem that is caused by:

1. Conditions, malfunctions or damage not resulting from defects in material or workmanship.
2. Conditions, malfunctions or damage resulting from normal wear and tear, improper installation, improper maintenance, misuse, abuse, negligence, accident or alteration.
3. Accessories, connected materials and products, or related products not manufactured by Flexispot.
4. Conditions, malfunctions or damage resulting from failure to follow the instructions and guidelines relating to the product's intended use.

Our limited warranty is void if a product is returned with removed, damaged or tampered labels or any alterations (including removal of any component or external cover).

How to File a Claim?

In order to receive the benefit of our limited warranty, you need to process your claim in compliance with the terms of this limited warranty and follow proper return procedure. To request warranty service, please contact customer service via email at contact@Flexispot.com or toll free at 855-421-2808. You will need to provide the sales receipt or other evidence of the date and place of purchase for your Flexispot product.

Implied Warranties and Limitation of Damages

EXCEPT TO THE EXTENT PROHIBITED BY APPLICABLE LAW, ALL IMPLIED WARRANTIES (INCLUDING WARRANTIES OF MERCHANTABILITY AND FITNESS FOR A PARTICULAR PURPOSE) SHALL BE LIMITED IN DURATION TO THE DURATION OF THIS WARRANTY, AND FLEXISPOT SHALL NOT BE LIABLE FOR ANY INCIDENTAL, INDIRECT, SPECIAL, OR CONSEQUENTIAL DAMAGES, INCLUDING BUT NOT LIMITED TO LOSS OF PROFITS OR REVENUE, RESULTING FROM ANY BREACH OF EXPRESS OR IMPLIED WARRANTY OR CONDITION, OR UNDER ANY OTHER LEGAL THEORY, EVEN IF FLEXISPOT HAS BEEN ADVISED OF THE POSSIBILITY OF SUCH DAMAGES. Some jurisdictions do not allow limitations on the duration of an implied warranty or the exclusion or limitation of special, indirect, incidental or consequential damages, so the above limitations or exclusions may not apply to you.

Governing Law

This Warranty shall be governed by the laws of the State of California, USA, without giving effect to any conflict of laws principles that may provide the application of the law of another jurisdiction.

How State Law Applies

This Warranty gives you specific legal rights, and you may also have other rights which vary from state to state.

FlexiSpot



Item No. BS8G
Installation Guide

PARTS

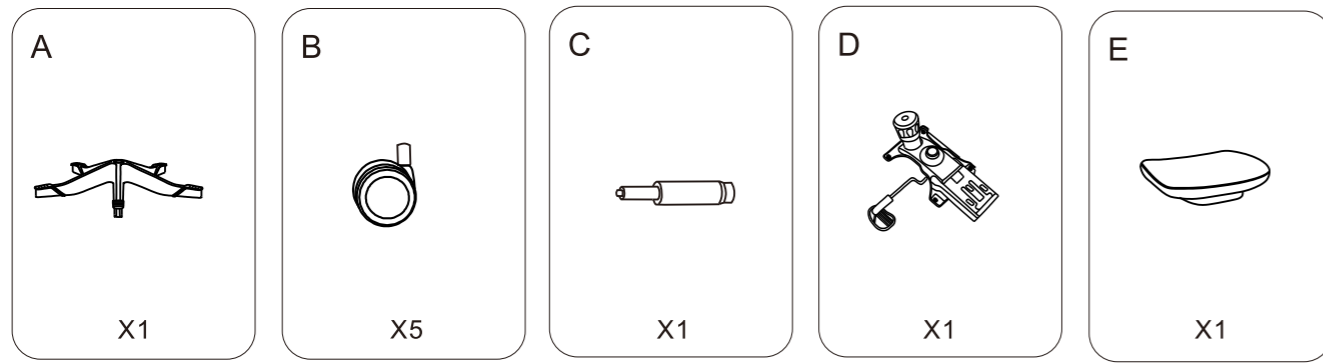

Seat Base

Wheel

Gas Lift

Mechanism

Seat

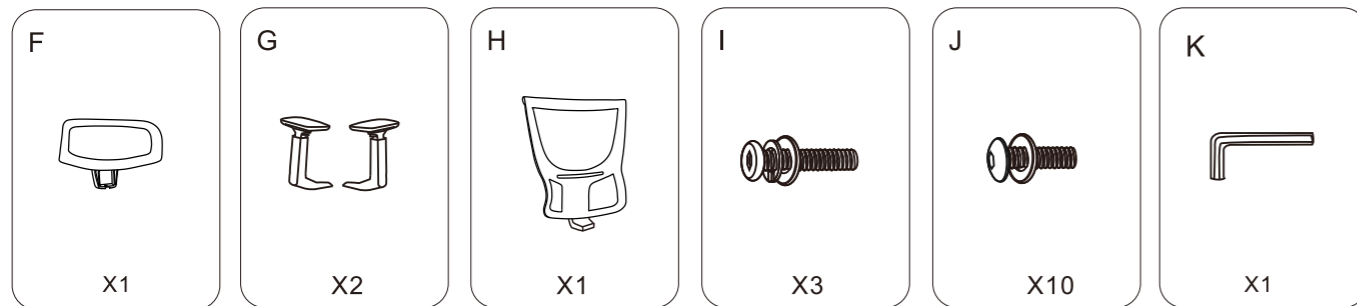

Head Rest

Armrests

Seat Back

M8X20
M8
M8X16X2

M6X40
M6
M6X15X1.5

Wrench

Step 1

Install the five Wheels (B) on Seat Base (A).

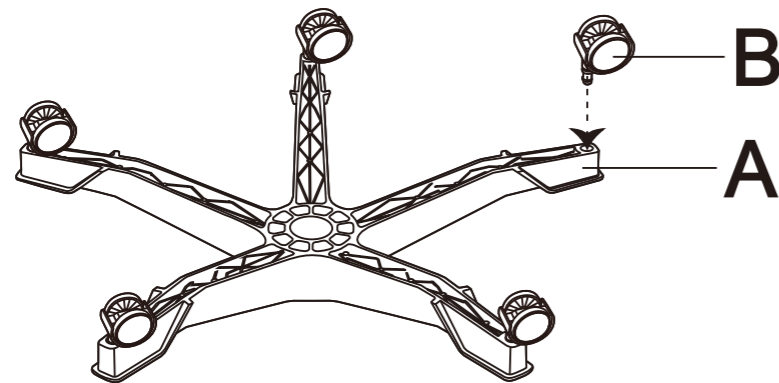

Step 2

Insert Gas Lift (C) to the Base (A).

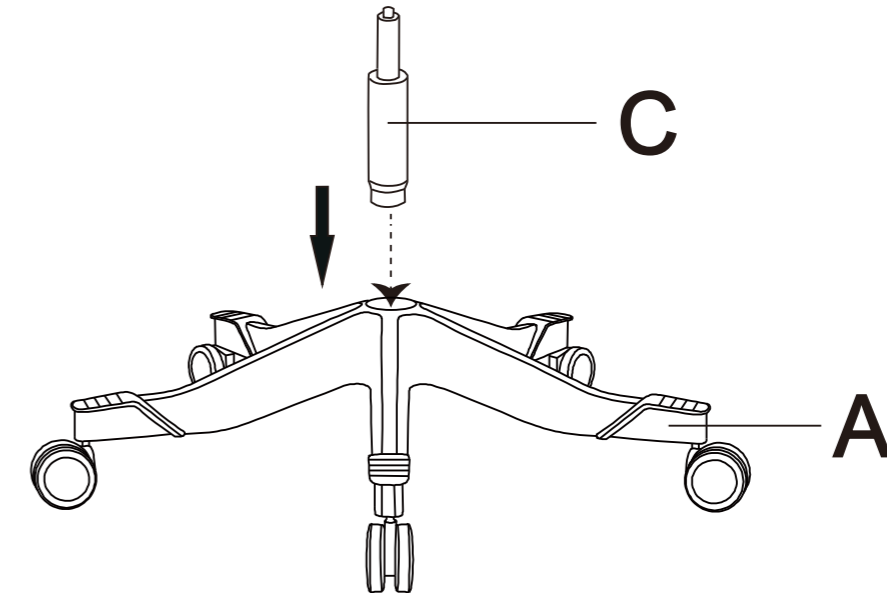

Step 3

Fix Left and Right Armrests (G) on the Seat (E) with screw (J).

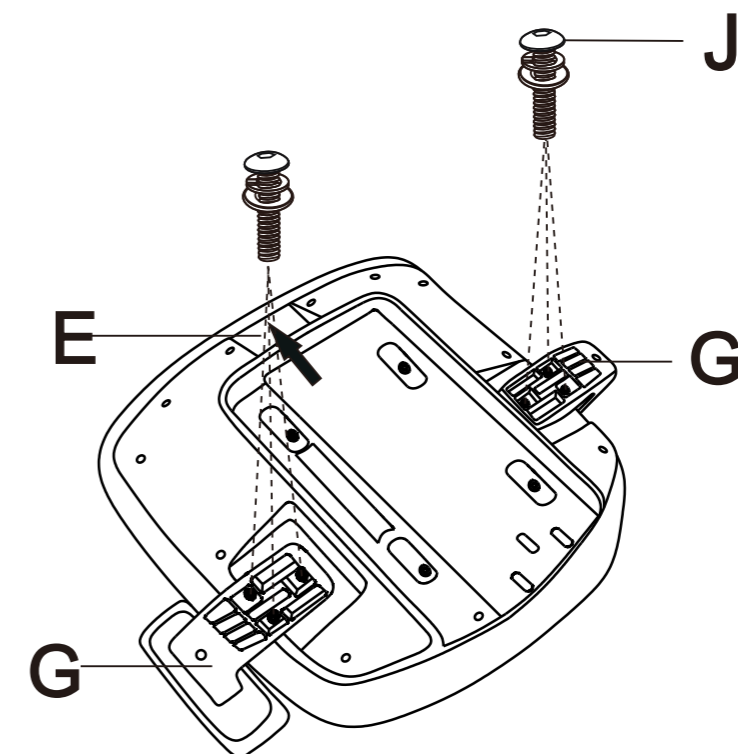

Step 4

Install Mechanism (D) on the Seat (E) with screw (J).

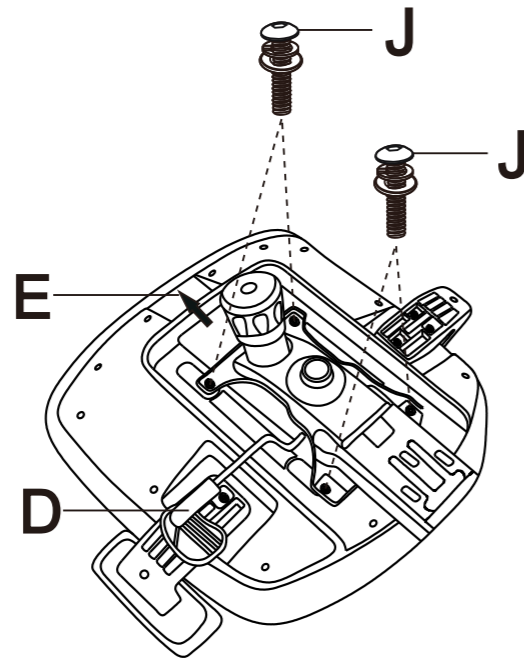

Step 5

Fix Seat Back (H) on the Mechanism (D) with screw (I).

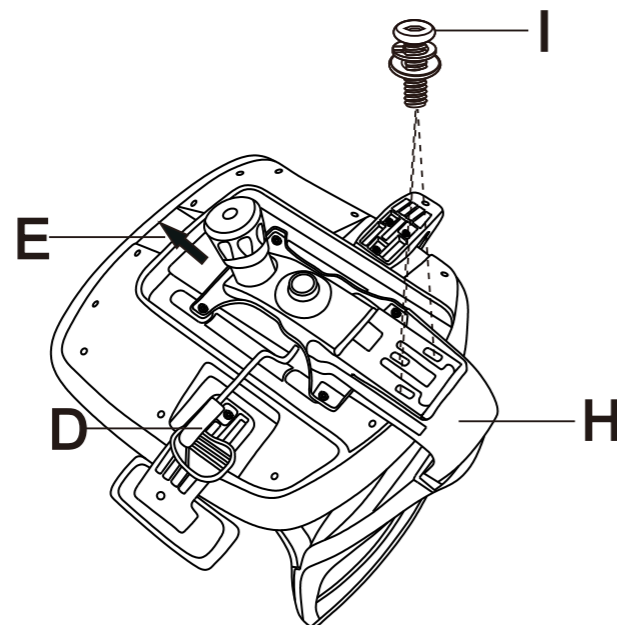

Step 6

Take the screw out of the Headrest (F) first. After the Headrest is stuck on the Seat Back (H), Insert the screw into the Headrest and tighten it with Wrench (K).

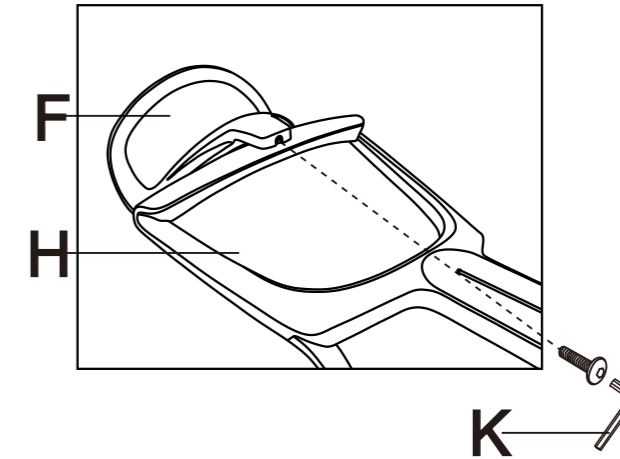

Step 7

Finally, you can enjoy this comfortable chair.

Put the whole Seat Part onto the Gas Lift (C).

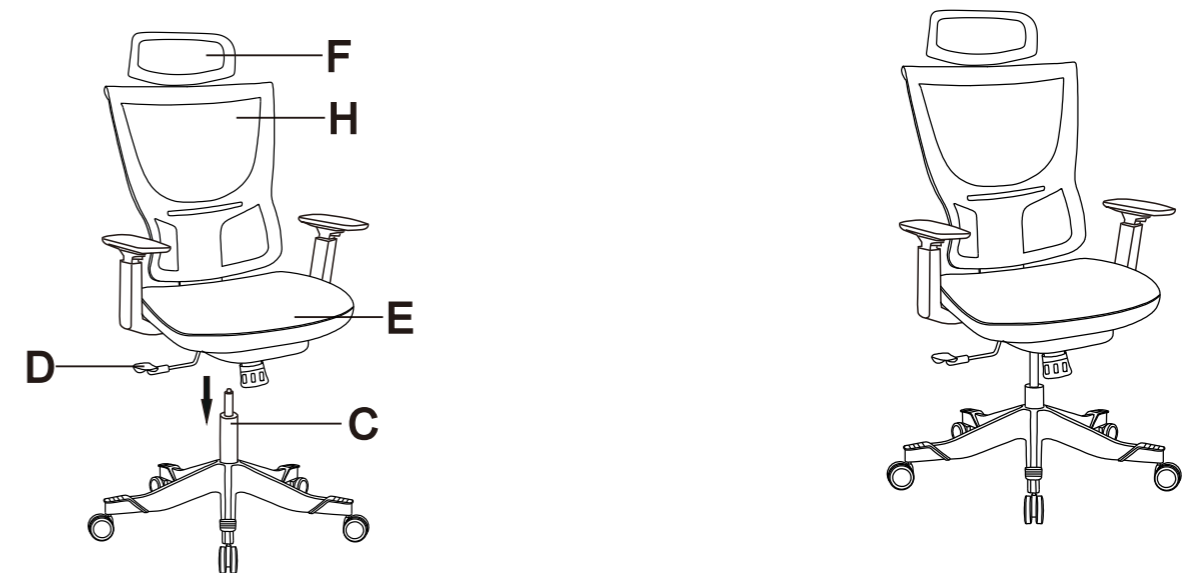

WARNING

FAILURE TO FOLLOW THESE INSTRUCTIONS MAY RESULT IN SERIOUS INJURY

1. THIS PRODUCT IS DESIGNED FOR SEATING ONLY. DO NOT STAND ON THIS PRODUCT. DO NOT USE IT AS A STEP LADDER
2. DO NOT USE THIS PRODUCT UNLESS ALL BOLTS AND PARTS ARE FIRMLY TIGHTENED. AT LEAST WITHIN 3 MONTHS, YOU HAVE TO CHECK ALL THE PARTS FOR SAFETY USE.
3. IF ANY PARTS ARE MISSING, DAMAGED OR WORN, STOP USING THIS PRODUCT, REPAIR THE PRODUCT WITH MANUFACTURER'S SUPPLIED PARTS.
4. DO NOT SIT ON THE ARMREST OF THIS PRODUCT.
5. THIS PRODUCT IS DESIGNED FOR SITTING ONE PERSON AT A TIME.
6. CHILDREN UNDER THE AGE OF 10, PLEASE USE UNDER ADULT SUPERVISION.

TEILE

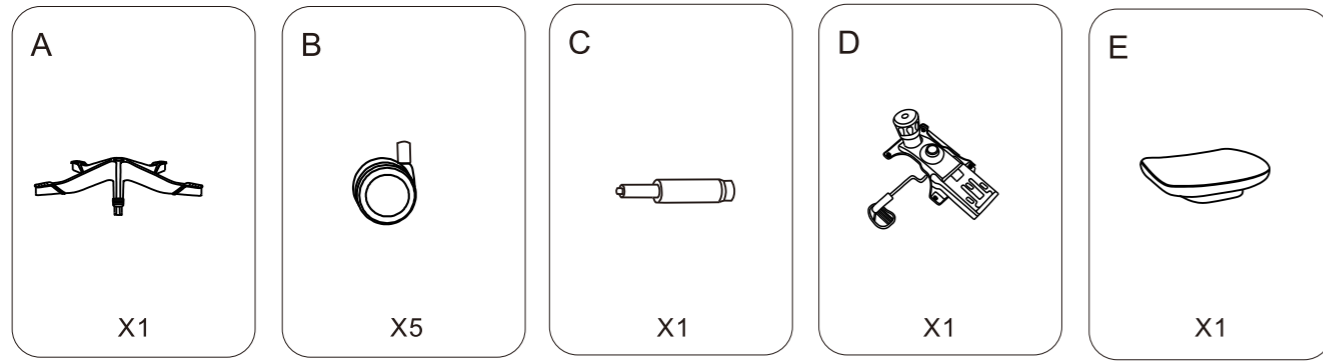

Fußkreuz

Lenkrolle

Gasdruckfeder

Mechanik

Sitz

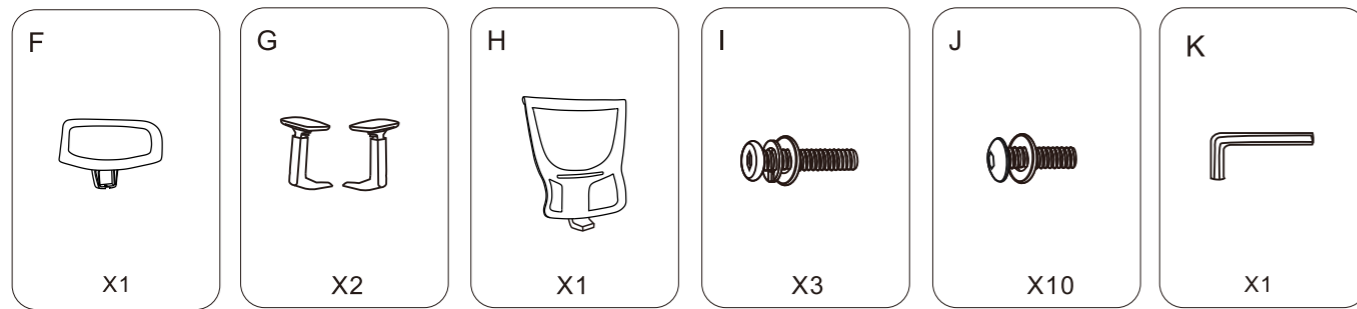

Kopfstütze

Armlehne

Rückenlehne

M8X20
M8
M8X16X2

M6X40
M6
M6X15X1.5

Schraubenschlüssel

Schritt 1

Montieren Sie die 5 Lenkrollen (B) auf das Fußkreuz (A).

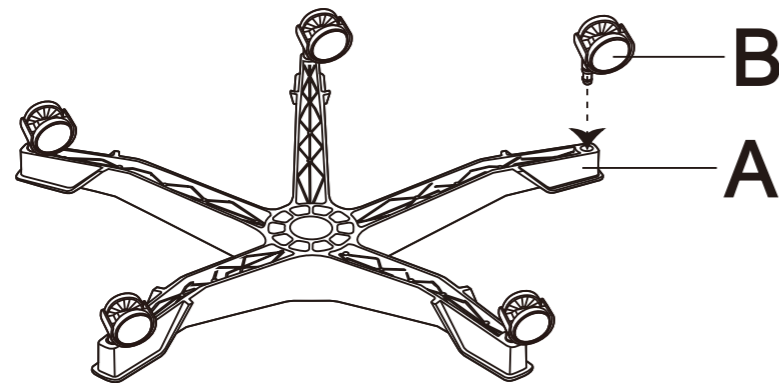

Schritt 2

Setzen Sie die Gasdruckfeder (C) ins Fußkreuz (A) ein.

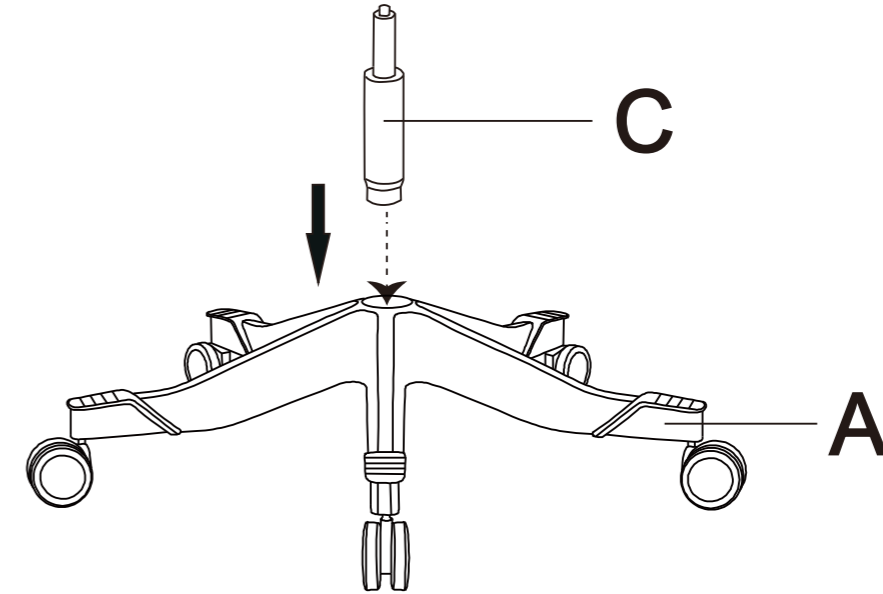

Schritt 3

Befestigen Sie linke und rechte Armlehne (G) mit Schrauben (J) am Sitz (E).

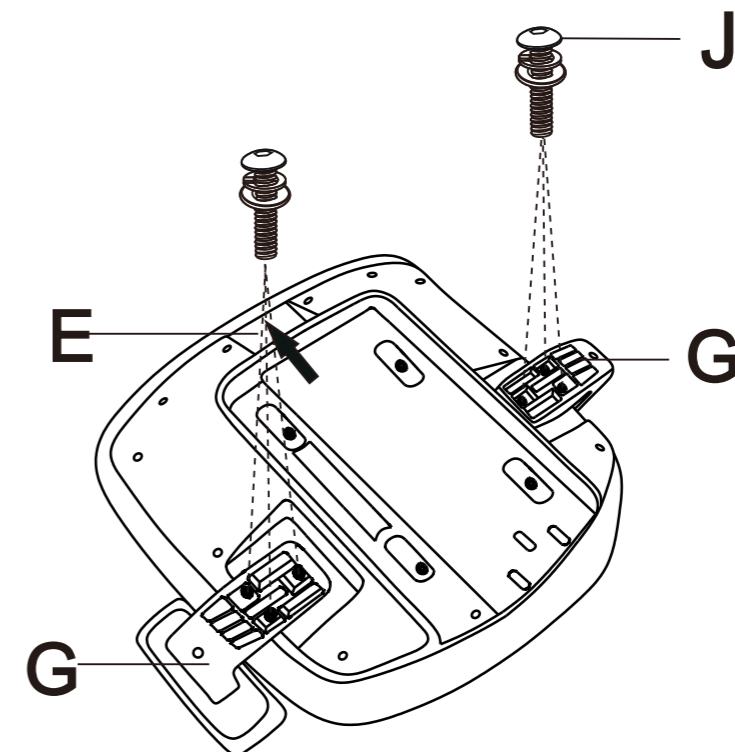

Schritt 4

Montieren Sie die Mechanik (D) mit Schrauben (J) auf das Sitz (E).

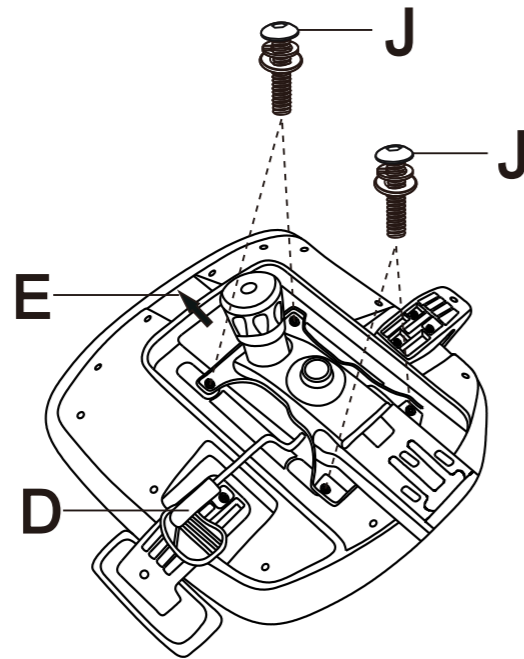

Schritt 5

Befestigen Sie die Rückenlehne (H) mit Schrauben (I) an der Mechanik (D).

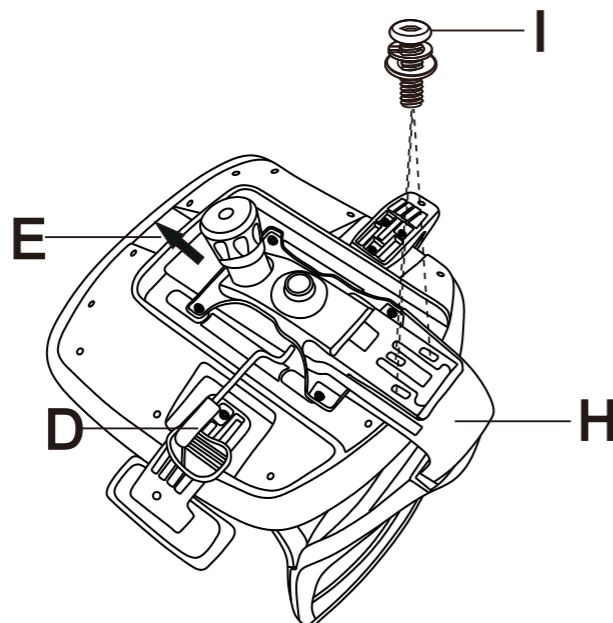

Schritt 6

Nehmen Sie zuerst die Schraube aus der Kopfstütze (F) heraus. Nachdem die Kopfstütze an der Rückenlehne (H) geklemmt ist, stecken Sie die Schraube in die Kopfstütze ein und ziehen Sie diese mit dem Schraubenschlüssel (K) an.

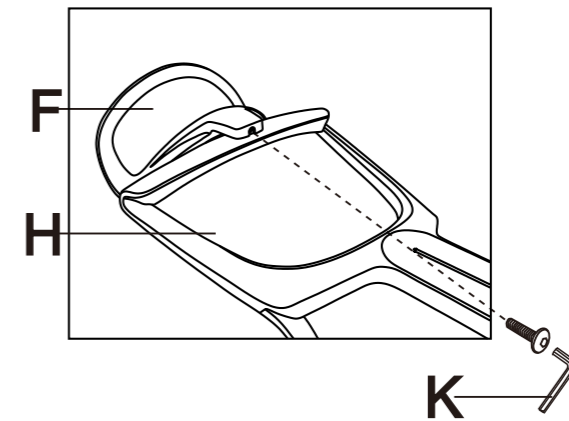

Schritt 7

Endlich können Sie diesen bequemen Stuhl genießen.

Setzen Sie das gesamte Sitzteil auf die Gasdruckfeder (C).

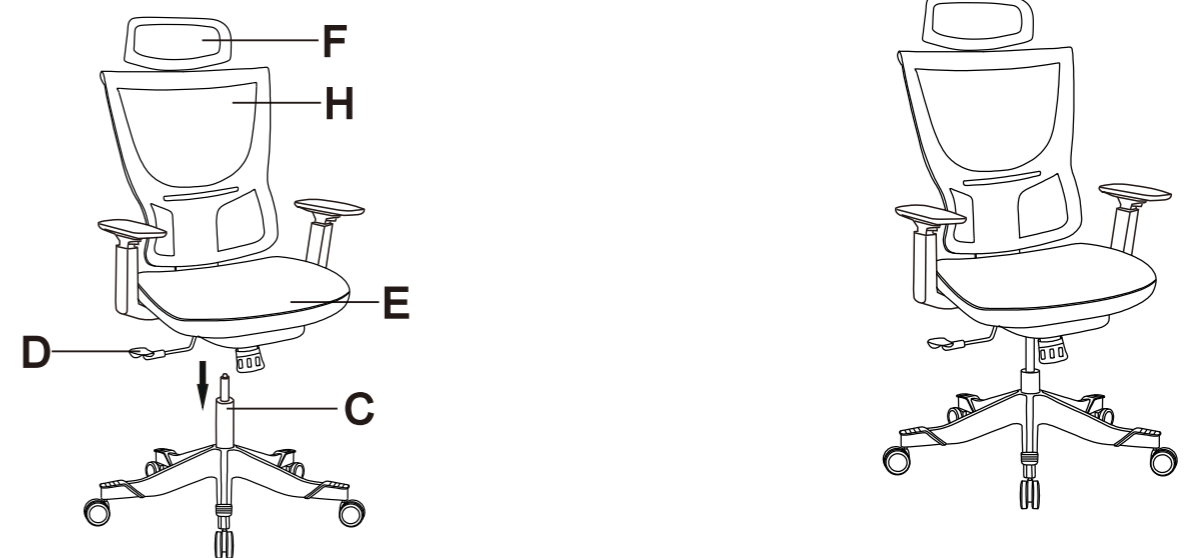

ACHTUNG

- DIE NICHTBEACHTUNG DIESER ANWEISUNGEN KANN ZU SCHWEREN VERLETZUNGEN FÜHREN.
1. DIESES PRODUKT IST NUR ZUM SITZEN VORGEGEHEN. STEHEN SIE NICHT AUF DIESEM PRODUKT. VERWENDEN SIE ES NICHT ALS TRITTLITER.
 2. VERWENDEN SIE DIESES PRODUKT NICHT, WENN NICHT ALLE SCHRAUBEN UND TEILE FEST ANGEZOGEN SIND. MINDESTENS INNERHALB VON 3 MONATEN MÜSSEN SIE ALLE TEILE AUF SICHEREN GEBRAUCH PRÜFEN.
 3. WENN TEILE FEHLEN, BESCHÄDIGT ODER ABGENUTZT SIND, VERWENDEN SIE DAS PRODUKT NICHT WEITER UND REPARIEREN SIE ES MIT DEN VOM HERSTELLER GELIEFERTEN TEILEN.
 4. SETZEN SIE SICH NICHT AUF DER ARMLEHNE DIESES PRODUKTS.
 5. DIESES PRODUKT IST FÜR DAS SITZEN VON JEWEILS EINER PERSON AUSGELEGT.
 6. KINDER UNTER 10 JAHREN BITTE UNTER AUFSICHT VON ERWACHSENEN BENUTZEN.

PARTAGE

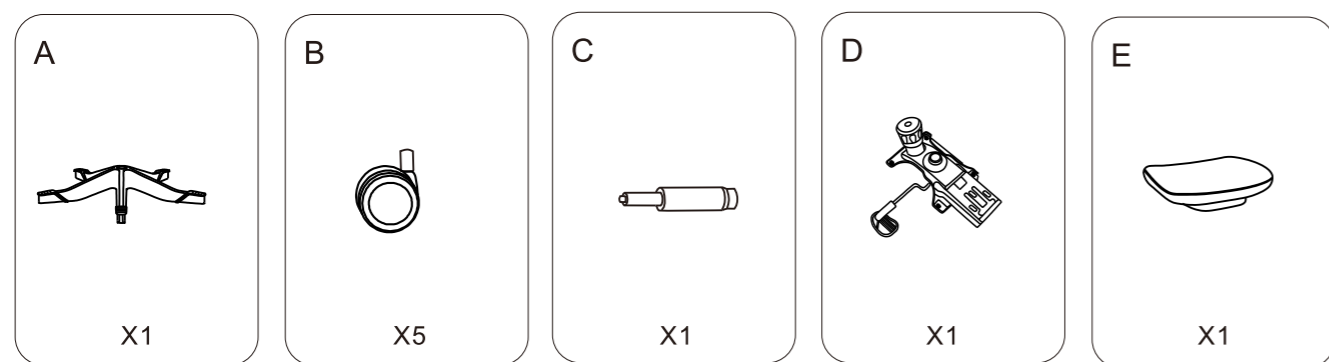

Piètement

Roulette pivotante

Vérin à gaz

Mécanisme

Siège

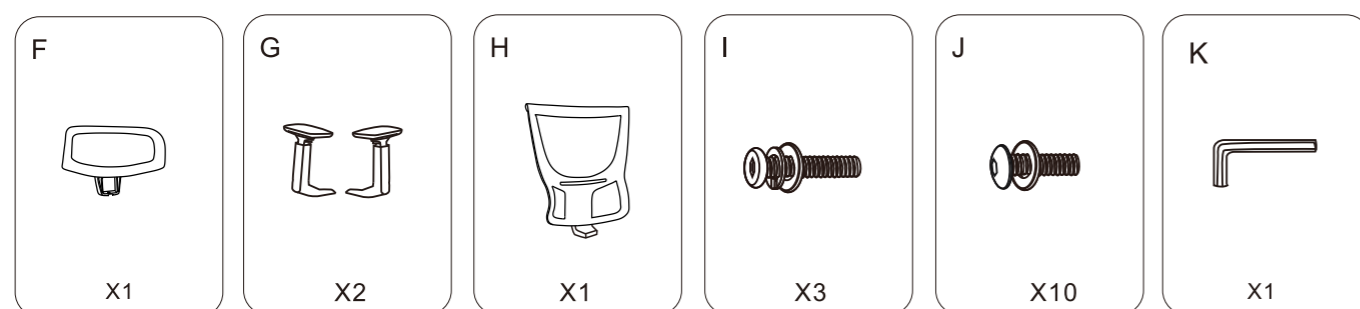

Appui-tête

Accoudoirs

Dossier

M8X20
M8
M8X16X2

M6X40
M6
M6X15X1.5

Raccords
de vis

Étape 1

Montez les 5 roulettes pivotantes (B) sur le piètement (A).

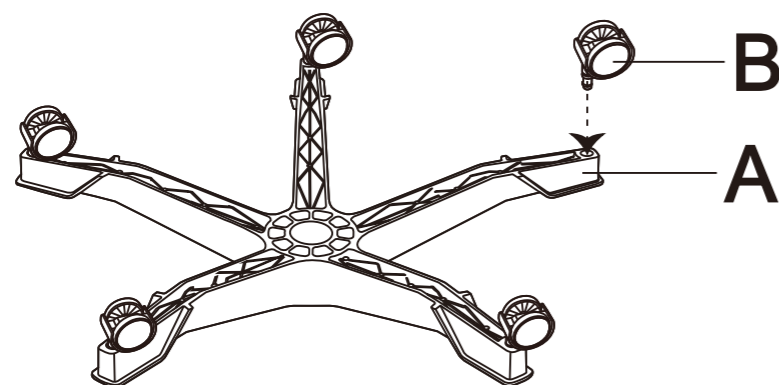

Étape 2

Placez le ressort à gaz (C) dans le piètement (A).

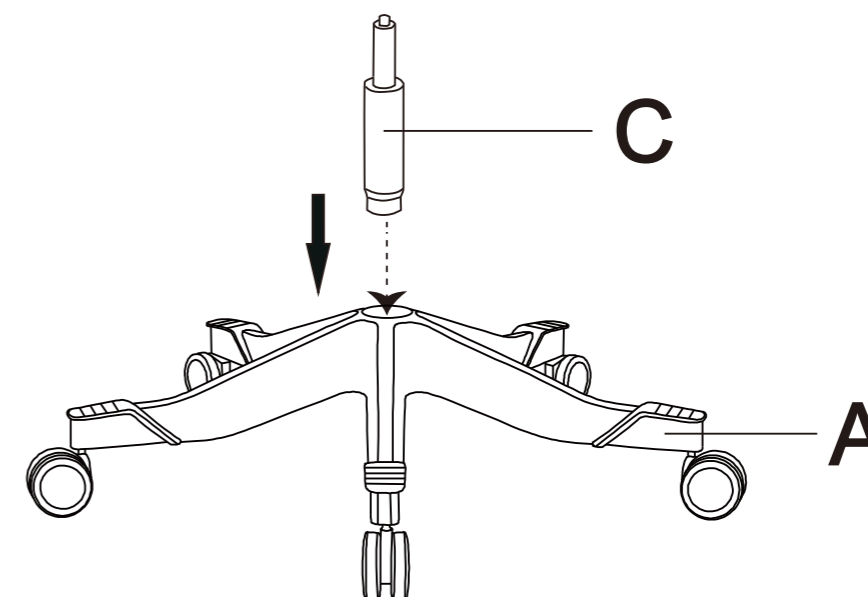

Étape 3

Fixez les accoudoirs gauche et droit (G) au siège (E) avec des vis (J).

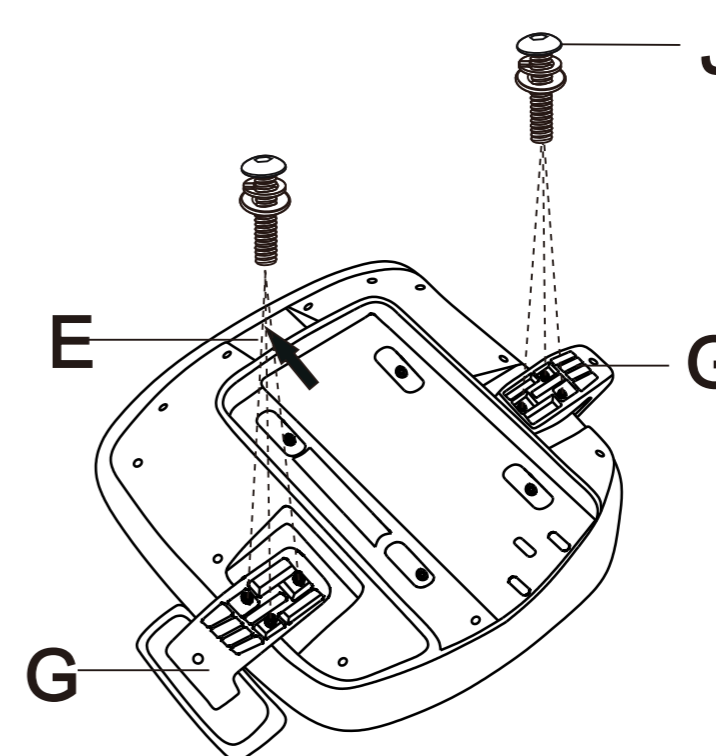

Étape 4

Montez le mécanisme (D) sur le siège (E) avec des vis (J).

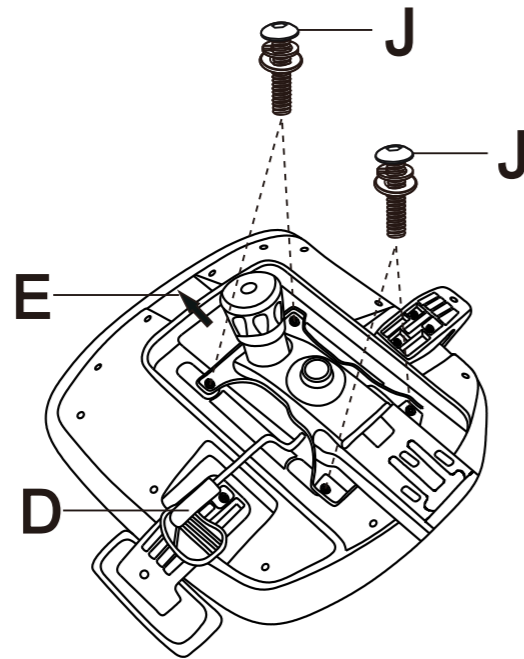

Étape 5

Fixez le dossier (H) au mécanisme (D) à l'aide de vis (I).

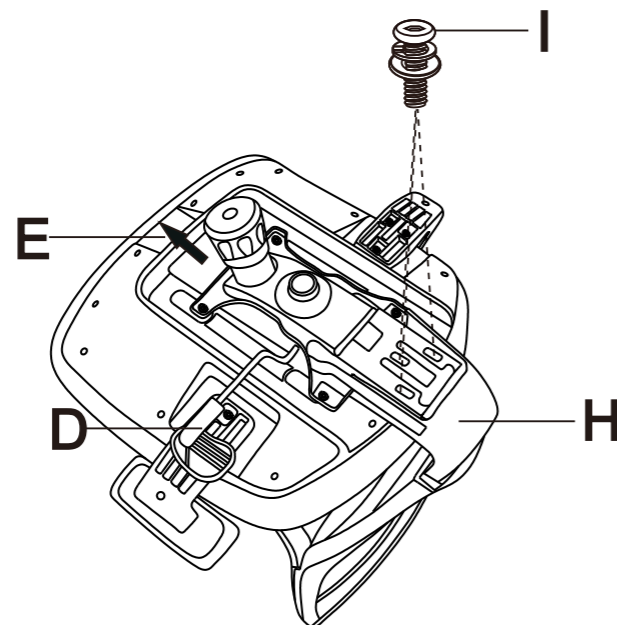

Étape 6

Retirez d'abord la vis de l'appuie-tête (F). Une fois l'appuie-tête fixé au dossier (H) dossier (H), insérez la vis dans l'appuie-tête et serrez la vis. à l'aide de la clé (K).

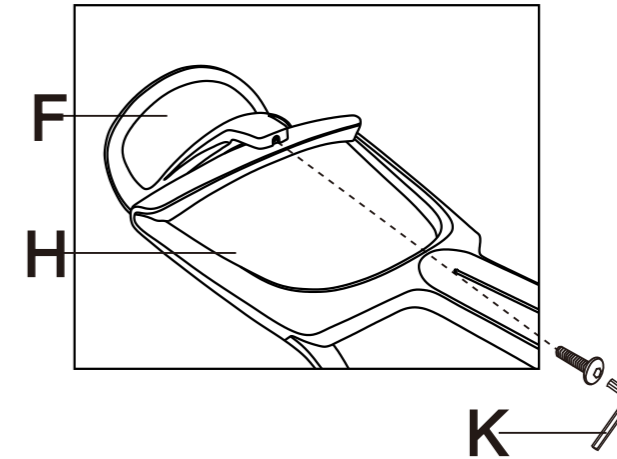

Étape 7

Vous pouvez enfin profiter de cette chaise confortable.

Placer l'ensemble du siège sur le ressort à gaz (C).

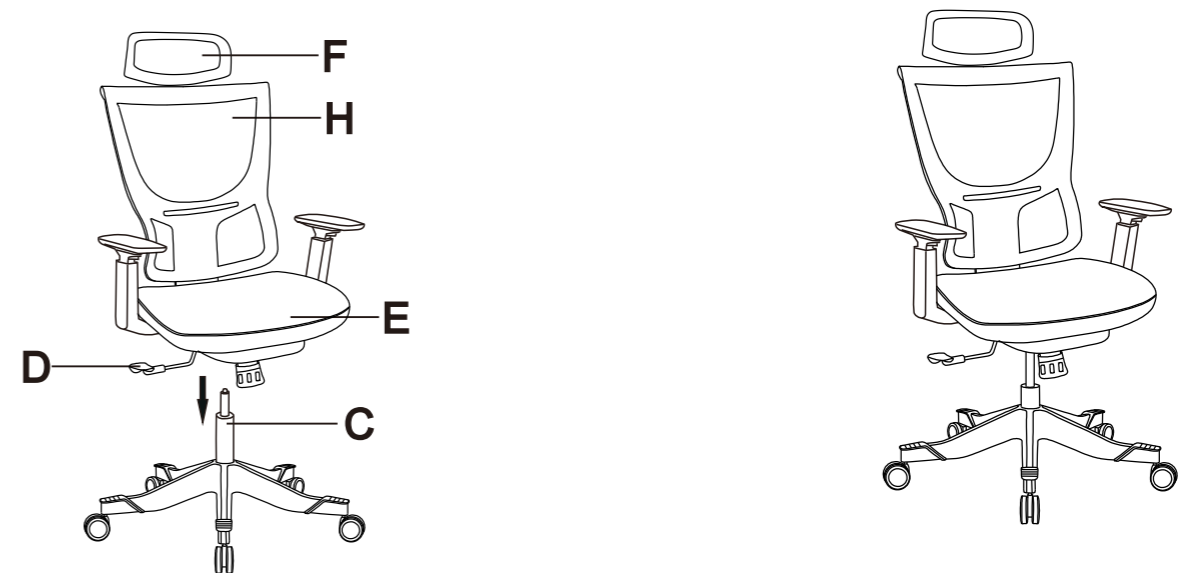

ATTENTION

- LE NON-RESPECT DE CES INSTRUCTIONS PEUT ENTRAÎNER DE GRAVES BLESSURES.
1. CE PRODUIT EST UNIQUEMENT DESTINÉ À ÊTRE UTILISÉ EN POSITION ASSISE. NE VOUS TENEZ PAS DEBOUT SUR CE PRODUIT. NE L'UTILISEZ PAS COMME MARCHEPIED.
 2. N'UTILISEZ PAS CE PRODUIT SI TOUTES LES VIS ET PIÈCES NE SONT PAS BIEN SERRÉES. AU MOINS DANS LES 3 MOIS, VOUS DEVEZ VÉRIFIER QUE TOUTES LES PIÈCES SONT UTILISÉES EN TOUTE SÉCURITÉ.
 3. SI DES PIÈCES MANQUENT, SONT ENDOMMAGÉES OU USÉES, N'UTILISEZ PLUS LE PRODUIT ET RÉPAREZ-LE AVEC LES PIÈCES FOURNIES PAR LE FABRICANT.
 4. NE VOUS ASSEYEZ PAS SUR L'ACCOUDOIR DE CE PRODUIT.
 5. CE PRODUIT EST CONÇU POUR ÊTRE UTILISÉ PAR UNE SEULE PERSONNE À LA FOIS.
 6. LES ENFANTS DE MOINS DE 10 ANS DOIVENT ÊTRE UTILISÉS SOUS LA SURVEILLANCE D'UN ADULTE.

PARTI

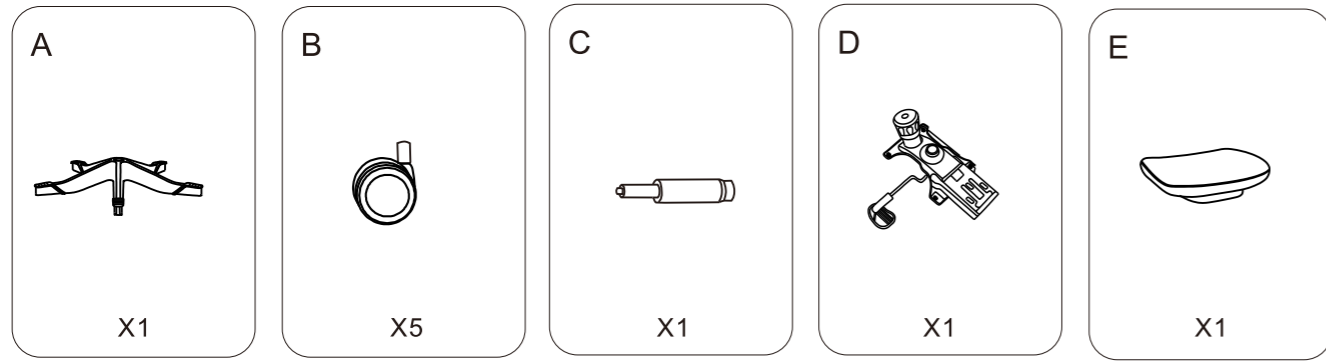

A Base del sedile X1 B Ruota X5 C Alzata a gas X1 D Meccanismo X1 E Posto a sedere X1

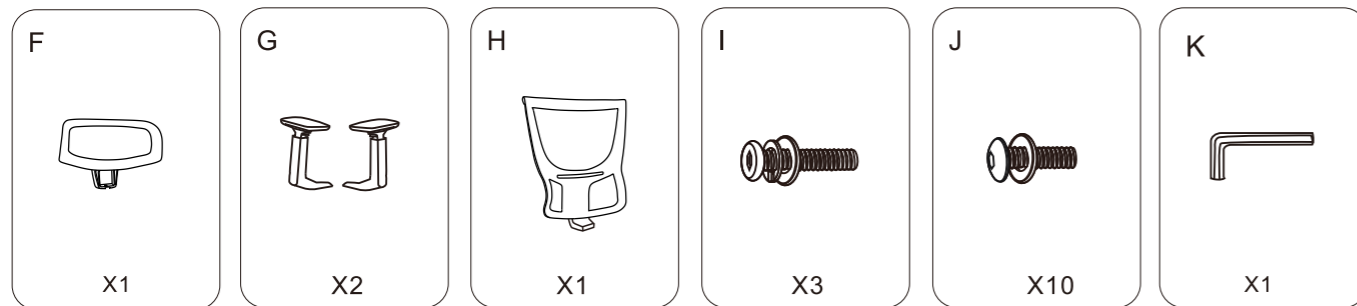

F Poggiatesta X1 G Braccioli X2 H Schienale della sedia X1 I M8X20 M8 M8X16X2 X3 J M6X40 M6 M6X15X1.5 X10 K Chiave inglese X1

PASSO 1

Installare le cinque ruote (B) sulla base del sedile (A).

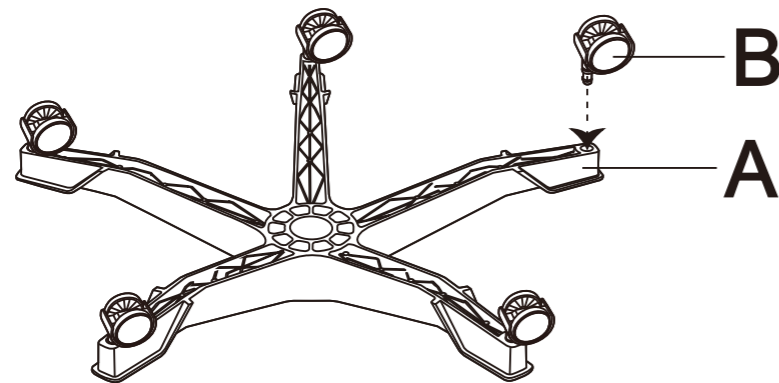

PASSO 2

Inserire l'alzata a gas (C) nella base (A).

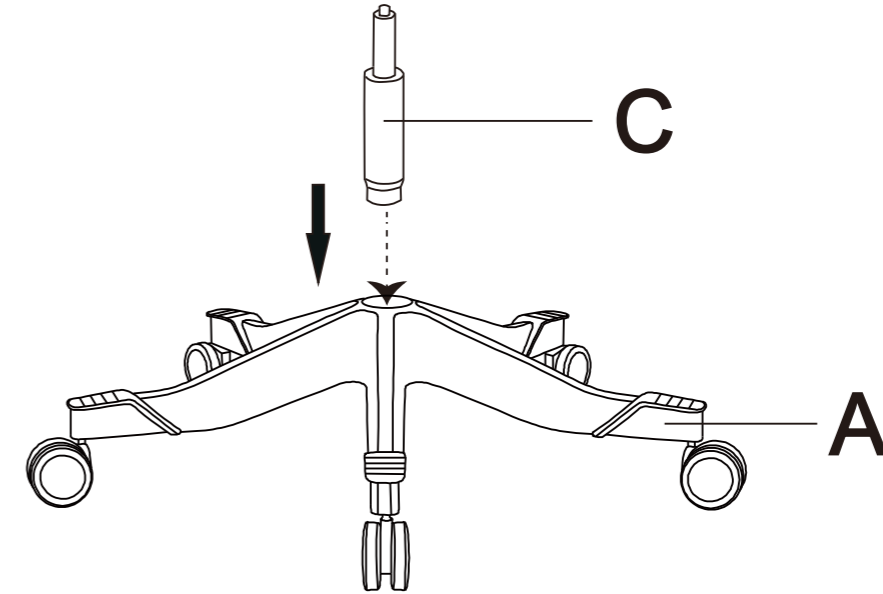

PASSO 3

Fissare i braccioli destro e sinistro (G) al sedile (E) con la vite (J).

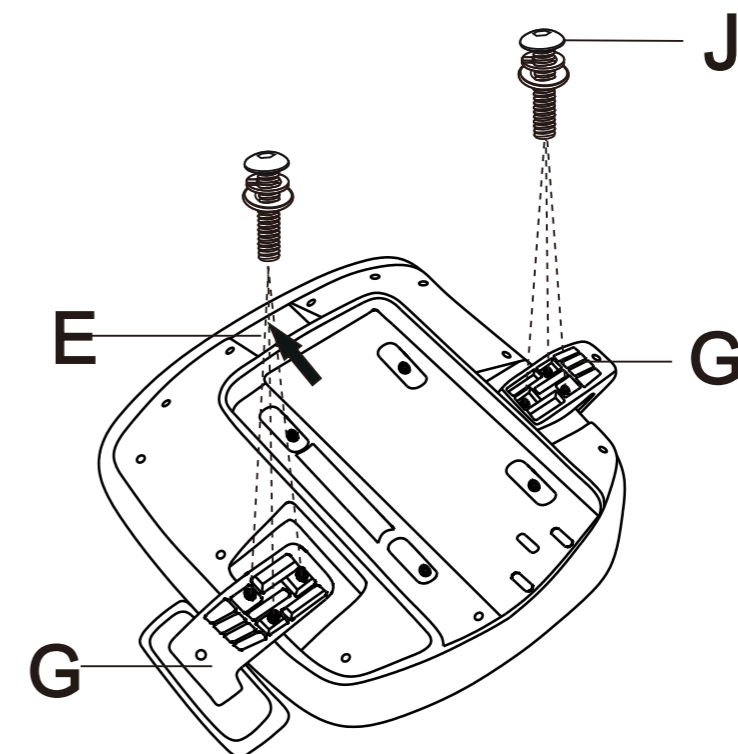

PASSO 4

Installare il meccanismo (D) sulla sede (E) con la vite (J)

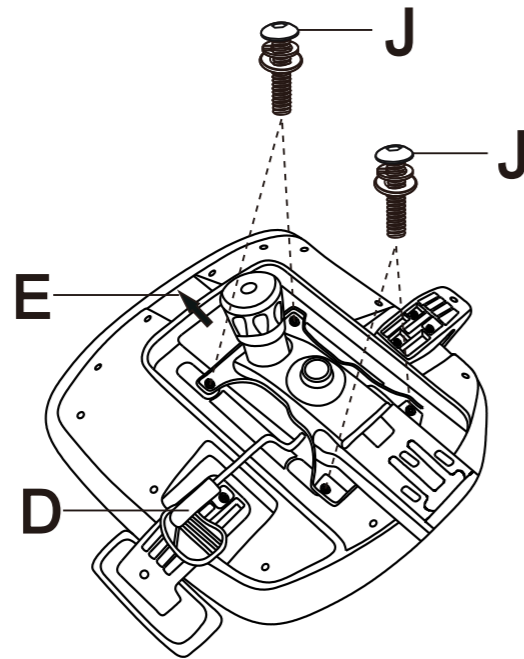

PASSO 5

Installare il meccanismo (D) sulla sede (E) con la vite (J).

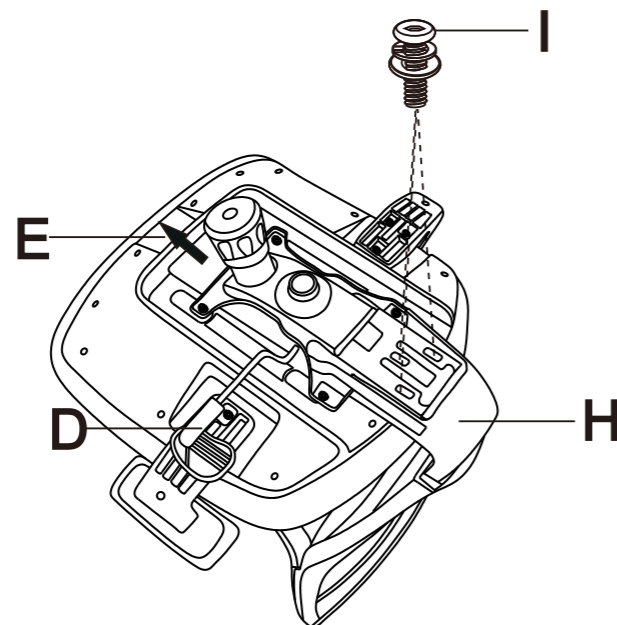

PASSO 6

Per prima cosa rimuovere la vite del poggiatesta (F). Dopo aver incollato il poggiatesta allo schienale del sedile (H), inserire la vite nel poggiatesta e serrarla con la CHIAVE (K).

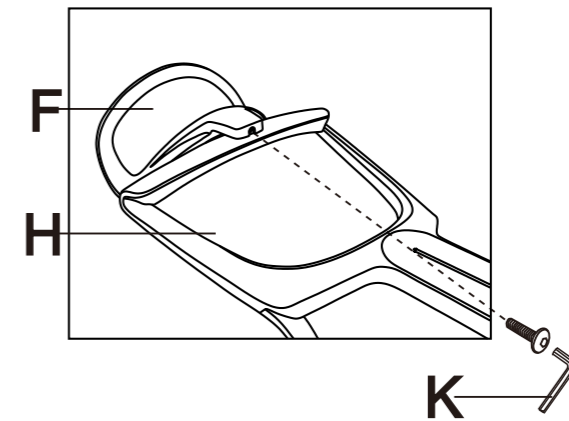

PASSO 7

Finalmente puoi goderti questa comoda sedia.

Posizionare l'intera parte del sedile sull'alzata a gas (C).

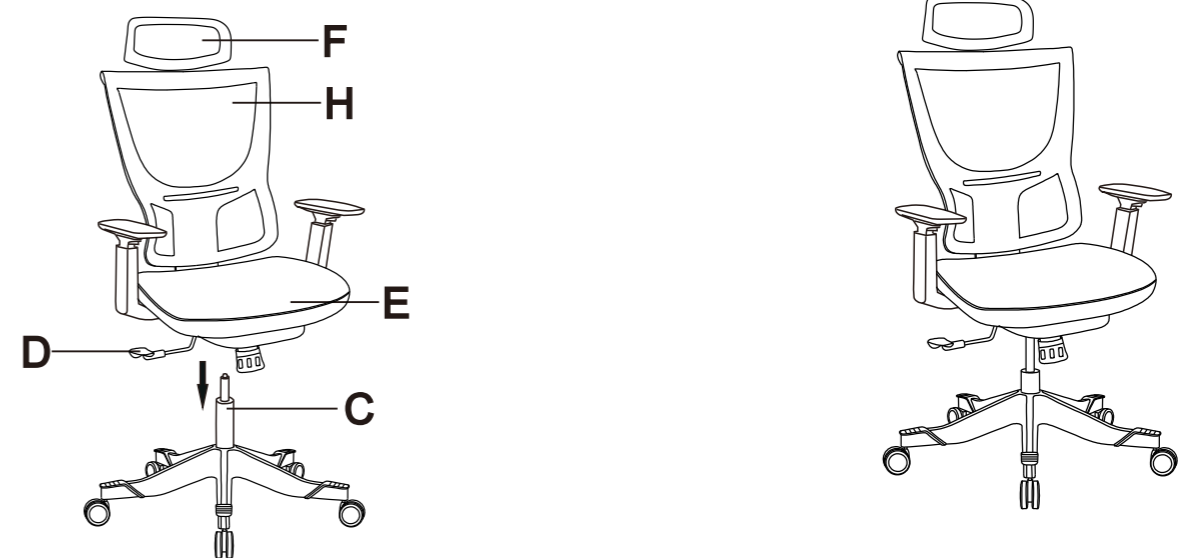

AVVERTIMENTO

IL MANCATO RISPETTO DI QUESTE ISTRUZIONI PUÒ CAUSARE GRAVI LESIONI

1. QUESTO PRODOTTO È DESTINATO SOLO PER SEDILI. NON STARE SU QUESTO PRODOTTO. NON USARLO COME SCALA
2. NON UTILIZZARE QUESTO PRODOTTO A MENO CHE TUTTI I BULLONI E LE PARTI SIANO SERRATI IN MODO SICURO. ALMENO ENTRO 3 MESI, DOVREBBE CONTROLLARE TUTTE LE PARTI PER UN USO IN SICUREZZA.
3. IN CASO DI PARTI MANCANTI, DANNEGGIATE O USURATE, INTERROMPERE L'USO DI QUESTO PRODOTTO E RIPARARE IL PRODOTTO CON LE PARTI FORNITE DAL PRODUTTORE.
4. NON SEDERSI SUI BRACCIOLI DI QUESTO PRODOTTO.
5. QUESTO PRODOTTO È PROGETTATO PER FAR SEDERE UNA PERSONA ALLA VOLTA.
6. BAMBINI SOTTO I 10 ANNI, UTILIZZARE SOTTO LA SUPERVISIONE DI UN ADULTO.

PIEZAS

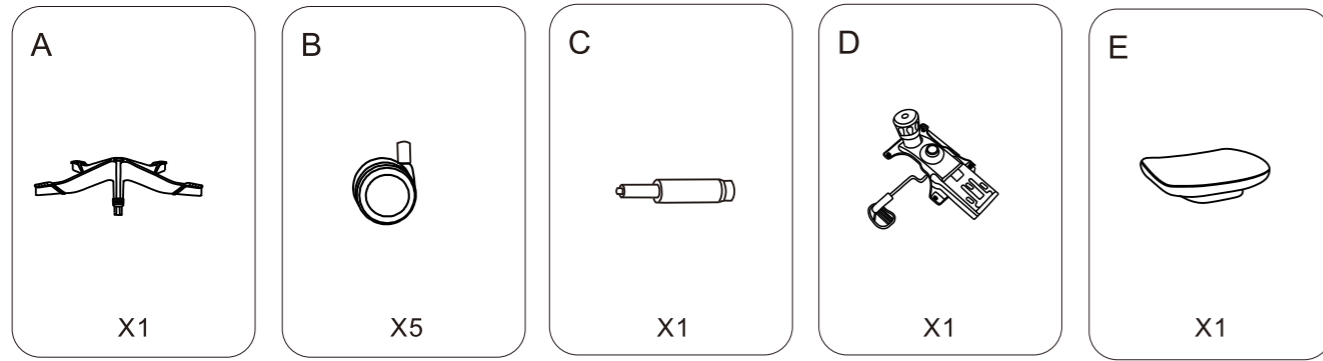

A
X1
Base del asiento

B
X5
Rueda

C
X1
Elevador de gas

D
X1
Mecanismo

E
X1
Asiento

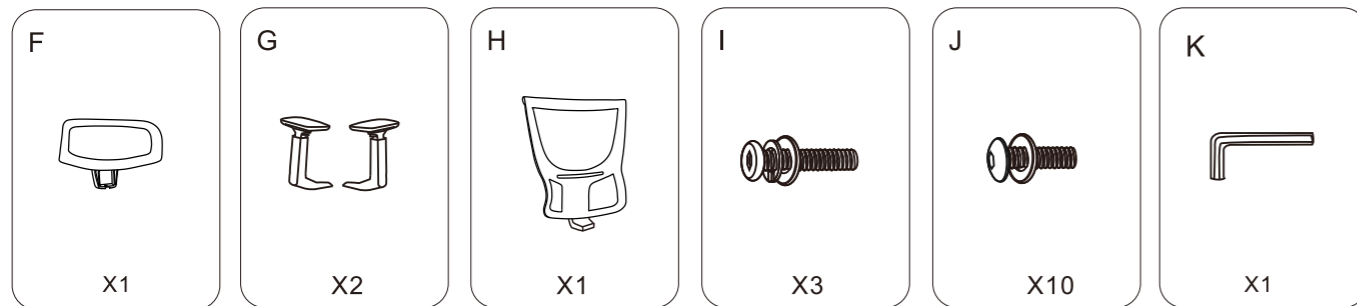

F
X1
Reposacabezas

G
X2
Reposabrazos

H
X1
Respaldo de silla

I
X3
M8X20
M8
M8X16X2

J
X10
M6X40
M6
M6X15X1.5

K
X1
Llave inglesa

PASO 1

Instale las cinco ruedas (B) en la base del asiento (A).

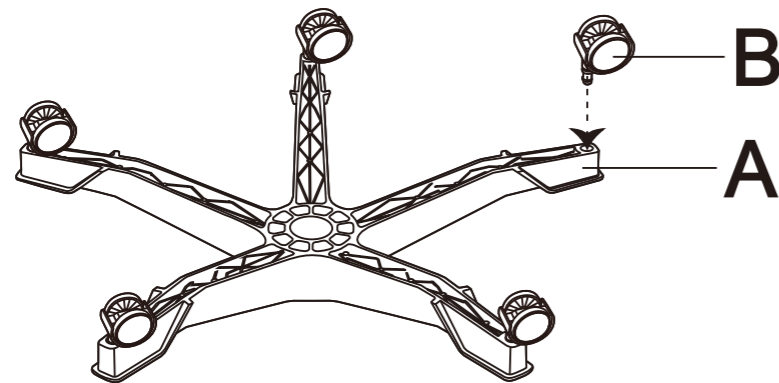

PASO 2

Inserte el elevador de gas (C) en la base (A).

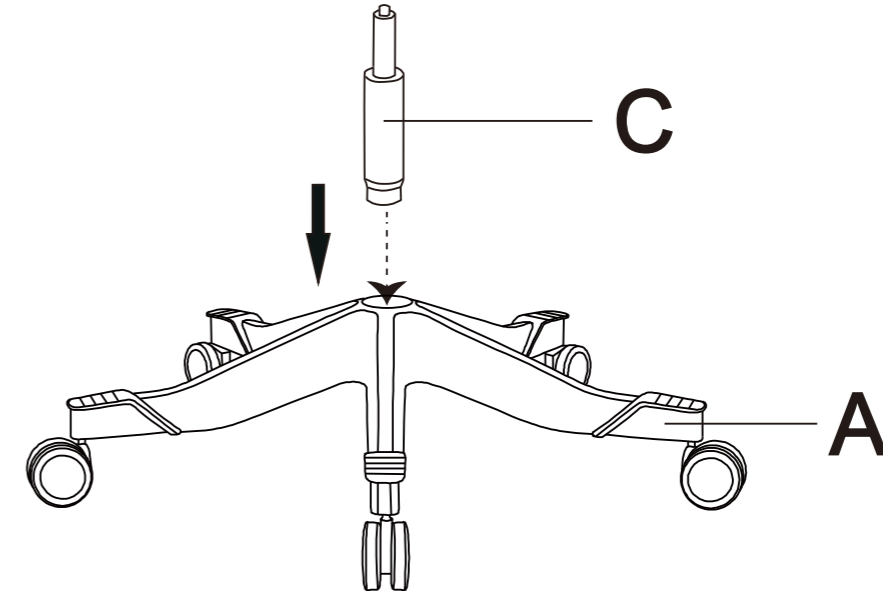

PASO 3

Fije los reposabrazos izquierdo y derecho (G) en el asiento (E) con el tornillo (J).

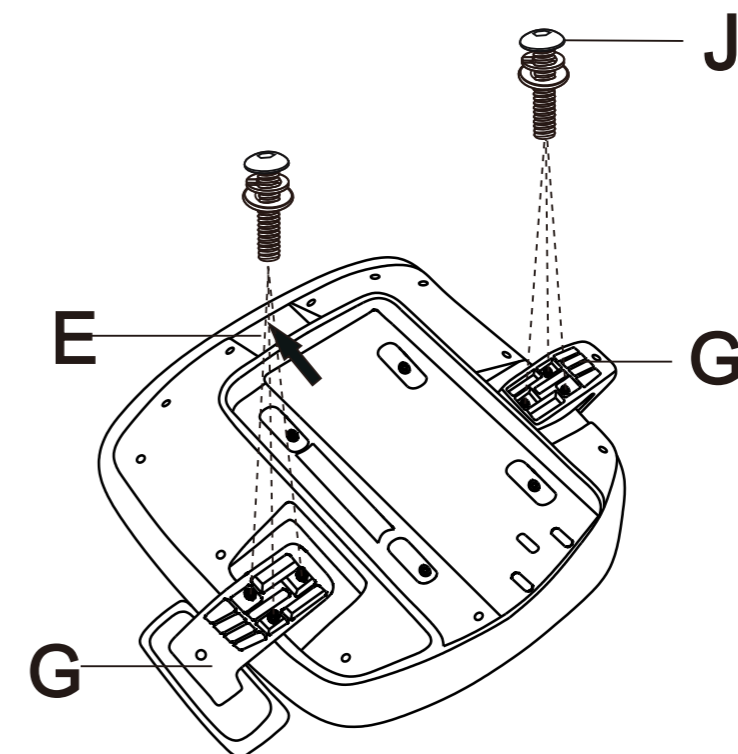

PASO 4

Instale el mecanismo (D) en el asiento (E) con el tornillo (J).

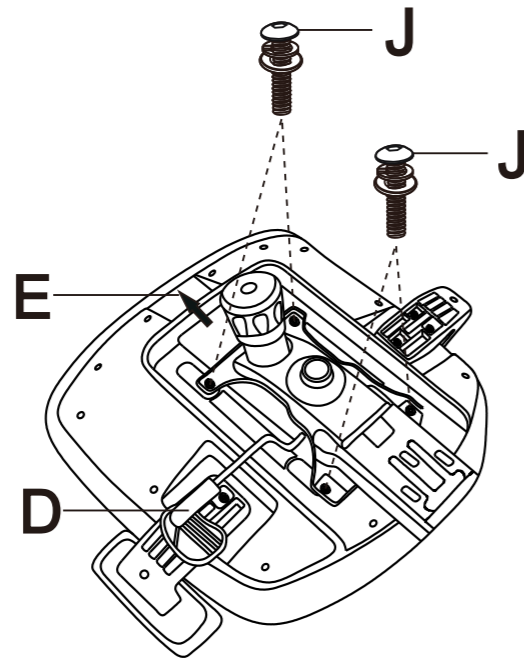

PASO 5

Fije el respaldo del asiento (H) en el mecanismo (D) con el tornillo (I).

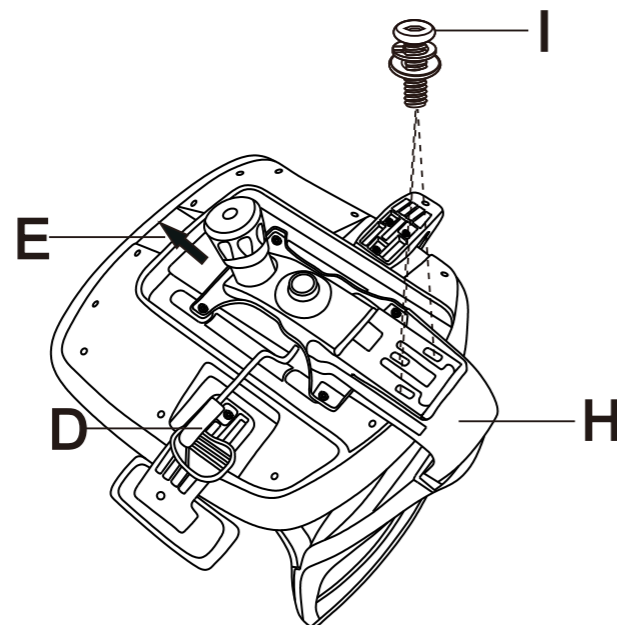

PASO 6

Saque primero el tornillo del reposacabezas (F). Después de que el reposacabezas esté atascado en el respaldo del asiento (H), inserte el tornillo en el reposacabezas y apriételo con la llave (K).

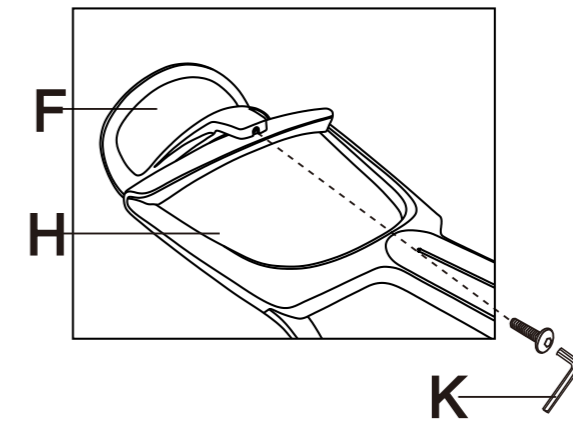

PASO 7

Por fin puedes disfrutar de esta cómoda silla.

Coloque toda la parte del asiento en el elevador de gas (C)

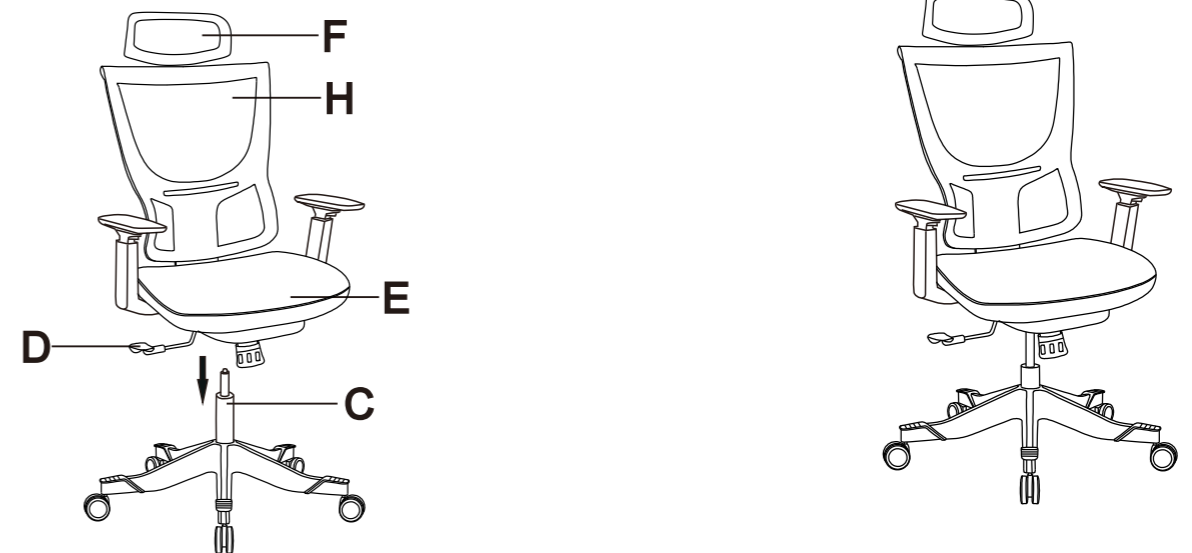

ADVERTENCIA

EL NO SEGUIR ESTAS INSTRUCCIONES PUEDE RESULTAR EN LESIONES GRAVES

1. ESTE PRODUCTO ESTÁ DISEÑADO SOLO PARA ASIENTOS. NO SE PARE SOBRE ESTE PRODUCTO. NO LO USE COMO ESCALERA
2. NO UTILICE ESTE PRODUCTO A MENOS QUE TODOS LOS PERNOS Y PIEZAS ESTÉN FIRMEMENTE APRETADOS. POR LO MENOS DENTRO DE 3 MESES, DEBE VERIFICAR TODAS LAS PIEZAS PARA USO DE SEGURIDAD.
3. SI FALTA ALGUNA PIEZA, ESTÁ DAÑADA O DESGASTADA, DEJE DE UTILIZAR ESTE PRODUCTO Y REPARE EL PRODUCTO CON LAS PIEZAS SUMINISTRADAS POR EL FABRICANTE.
4. NO SE SIENTE EN EL APOYABRAZOS DE ESTE PRODUCTO.
5. ESTE PRODUCTO ESTÁ DISEÑADO PARA QUE SE SIENTE UNA PERSONA A LA VEZ.
6. NIÑOS MENORES DE 10 AÑOS, USE BAJO LA SUPERVISIÓN DE UN ADULTO.