

INSTRUCTION

8W

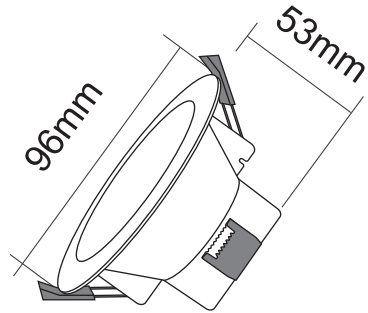

SKU: EN-D001

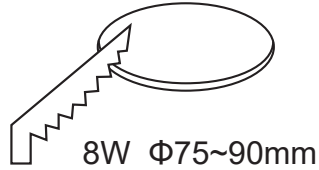

10W

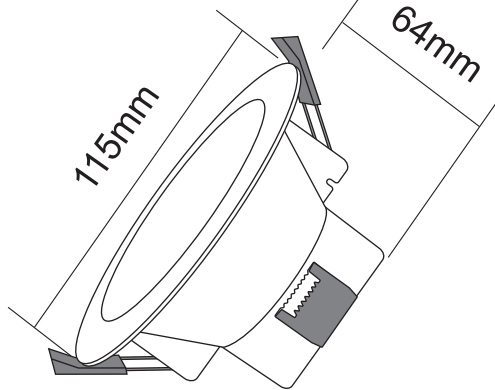

SKU: EN-D002

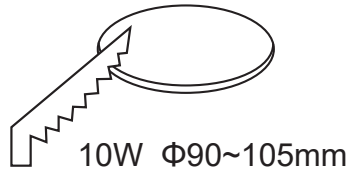

12W

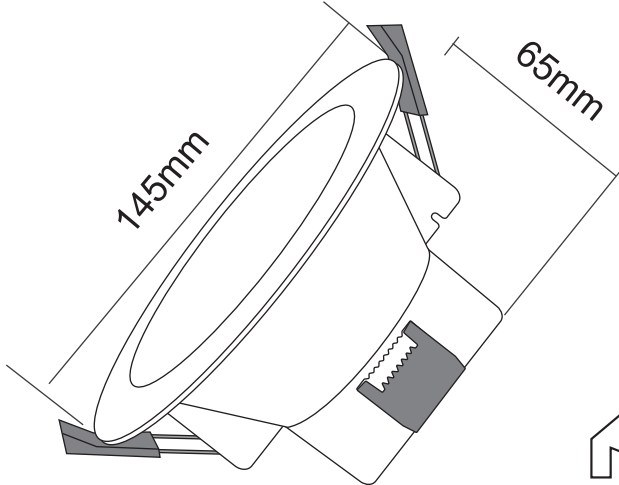

SKU: EN-D003

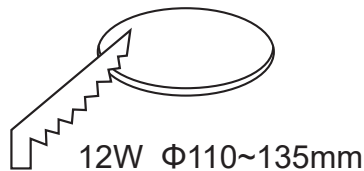

Step 1:
Use tool to cut appropriate hole in the ceiling

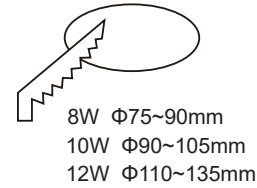

Step 2:
Open the terminal cover, and connect external circuit. L is connected with live line, N is connected with null line.

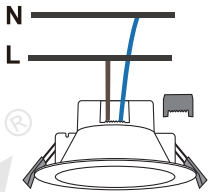

Step 3:
Push up the spring buckles vertically, insert to the ceiling hole.

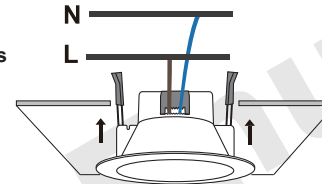

Step 4:
Release spring buckles to fasten lamp in ceiling

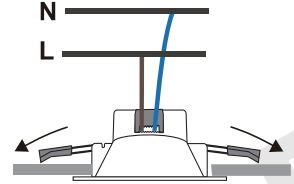

Power	8W	10W	12W
Dimmable Yes/No	Non Dimmable		Dimmable
Input voltage	AC100-240V, 50Hz/60Hz		AC220-240V, 50Hz/60Hz
Brightness	700Lm	900Lm	1100Lm
Lighting source	SMD2835 LED		
Lighting color	Warm white 3000K/ Natural white 4000K/ Cool white 5000K		
CRI: CRI>80	Beam angle: 110°		Waterproof: IP44

DE

LED Einbaustrahler

Leistung	8W	10W	12W
Dimmbar Ja/Nr	Nicht Dimmbar		Dimmbar
Eingangsspannung	AC100-240V, 50Hz/60Hz		AC220-240V, 50Hz/60Hz
Helligkeit	700Lm	900Lm	1100Lm
Lichtquelle	SMD2835 LED		
Lichtfarbe	Warm weiß 3000K/ Natürliches Weiß 4000K/ Kaltes weiß 5000K		
CRI: CRI>80	Abstrahlwinkel: 110°		Wasserdicht: IP44

Installationsmethode:

- Schneide ein Loch in die Decke. Und schalte die Stromversorgung vor der Installation aus.
- Drähte mit externem Stromkreis verbinden, brauner Draht ist mit Live-Leitung verbunden, blauer Draht ist mit Nulllinie verbunden.
- Schieben Sie die Federschnallen vertikal nach oben und setzen Sie die Lampe in das Deckenloch ein.
- Lösen Sie die Federschnallen, um die Lampe an der Decke zu befestigen. Die Installation ist beendet.

FR

Lampe Encastrable LED

Puissance	8W	10W	12W
Dimmable Oui/Non	Non Dimmable		Dimmable
Tension d'entrée	AC100-240V, 50Hz/60Hz		AC220-240V, 50Hz/60Hz
Luminosité	700Lm	900Lm	1100Lm
Source d'éclairage	SMD2835 LED		
Couleur d'éclairage	Blanc chaud 3000K/ Blanc naturel 4000K/ Blanc froid 5000K		
CRI: CRI>80	Angle de faisceau: 110°	Taux étanche: IP44	

Méthode d'installation:

1. Couper un trou dans le plafond. Et éteignez l'électricité avant l'installation.
2. Connectez les fils avec un circuit externe, le fil brun est connecté à la ligne en direct, le fil bleu est connecté à la ligne nulle.
3. Poussez les boucles de ressort verticalement et insérez la lampe sur le trou du plafond.
4. Relâchez les boucles de ressort pour fixer la lampe dans le plafond, l'installation est terminée.

IT

Lampada LED da Incasso

Energia	8W	10W	12W
Dimmerabile Si/No	Non Dimmerabile		Dimmerabile
Tensione di ingresso	AC100-240V, 50Hz/60Hz		AC220-240V, 50Hz/60Hz
Luminosità	700Lm	900Lm	1100Lm
Sorgente luminosa	SMD2835 LED		
Colore di illuminazione	Bianco caldo 3000K/ Bianco naturale 4000K/ Bianco freddo 5000K		
CRI: CRI>80	Angolo del fascio luminoso: 110°	Impermeabile: IP44	

Metodo di installazione:

1. Tagliare un foro nel soffitto. E spegnere l'energia elettrica prima dell'installazione.
2. Collegare i fili con circuito esterno, il filo marrone è collegato con la linea in tensione, il filo blu è collegato con la linea nullo.
3. Spingere verticalmente le fibbie della molla e inserire la lampada sul foro del soffitto.
4. Rilasciare fibbie molla per fissare la lampada a soffitto, installazione è terminata.

Imported By:

Ningbo Jiangbei Xinmu Dianzi Keji Youxian Gongsi
Zhejiang Sheng Ningbo Shi Jiangbei Qu Jiangbei Da
Dao 99 Hao 61 Zhuang 5-41Shi, Ningbo, 315000,
China

✉ service@enuotek.com

🌐 www.enuotek.com



ES

Lampara Empotrables LED

Poder	8W	10W	12W
Regulable Sí/No	No Regulable		Regulable
Voltaje de entrada	AC100-240V, 50Hz/60Hz		AC220-240V, 50Hz/60Hz
Brillo	700Lm	900Lm	1100Lm
Fuente de iluminación	SMD2835 LED		
Color de la iluminación	Blanco cálido 3000K/ Blanco natural 4000K/ Blanco frío 5000K		
CRI: CRI>80	Ángulo de haz: 110°	Impermeable: IP44	

Metodo de instalacion:

1. Corte un agujero en el techo. Y apague la electricidad antes de la instalación.
2. Conecte los cables con el circuito externo, el alambre marrón se conecta con la línea viva, el alambre azul se conecta con la línea nula.
3. Empuje hacia arriba las hebillas de muelle verticalmente e inserte la lámpara en el orificio del techo.
4. Suelte las hebillas de resorte para sujetar la lámpara en el techo, la instalación está terminada.

JP

LEDダウンライト

パワー	8W	10W	12W
調光可能/非調光	非調光		調光可能
電圧	AC100-240V, 50Hz/60Hz		AC220-240V, 50Hz/60Hz
照明の明るさ	700Lm	900Lm	1100Lm
照明源	SMD2835 LED		
照明色	電球色3000K/ ニュートラルライト4000K/ 昼白色5000K		
CRI: CRI>80	ビーム角: 110°	防水率: IP44	

インストール方法:

1. 天井に穴を開けます。また、設置前に電源を切ってください。
2. 外部回路と電線を接続し、ブラウンの電線はライブラインに接続し、青い電線はゼロ線で接続します。
3. スプリングバックルを垂直に上に押し、ランプを天井の穴に差し込みます。
4. スプリングバックルを放して、ランプを天井に固定し、取り付けは完了です。

Manufactured By:

SHAOXING SHANGYU HUATENG ELECTRICAL CO., LTD.
JINJIAO VILLAGE BAIGUAN STREET SHANGYU
DISTRICT SHAOXING CITY,ZHEJIANG, P.R. China

Made in China

UKCA REP Sea&Mew Accounting Ltd
10 Duke Street, Coventry CV5 8BZ
Compliance.SM@outlook.com

EC REP Like Sun GmbH
Planckstr.59 45147 Essen
ec-connection@web.de