

- |                         |                          |                      |
|-------------------------|--------------------------|----------------------|
| 2x<br>Nr.98             | 4x<br>6,3x11,5<br>Nr.535 |                      |
| 4x<br>Nr.315            | 4x<br>3,5x15<br>Nr.181   |                      |
| 2x<br>Nr.523            | 2x<br>6,3x13<br>Nr.274   | 2x<br>4x15<br>Nr.336 |
| 12x<br>3,5x15<br>Nr.181 | 6x<br>Nr.315             |                      |

# Montageanleitung

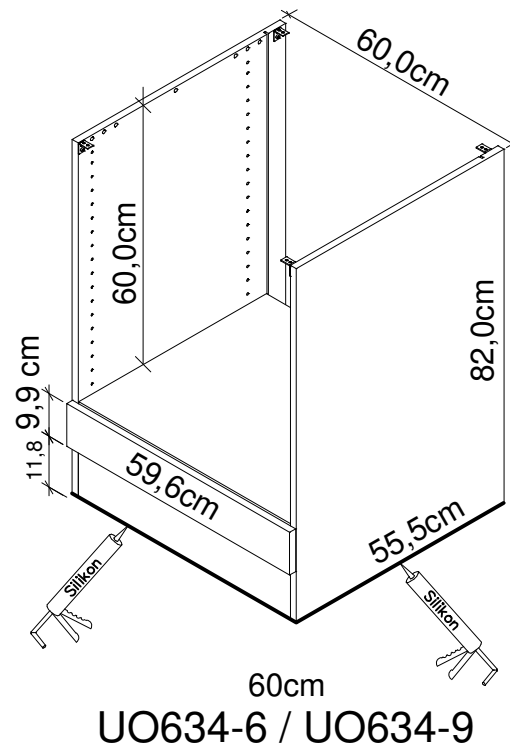

- A** weiß / buche  
white / beech  
blanc / hêtre  
wit / beuken  
blanco / haya  
bianco / faggio  
белый / бук  
biały / buk  
fehér / bükkfa  
bílý / buk  
bela / bukev  
valkoinen / pyökki  
vit / beech  
biely / buk  
alb / fag  
beyaz / kayın

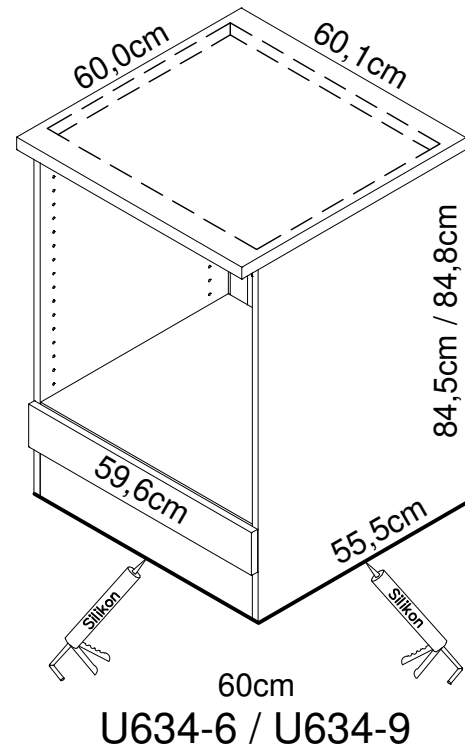
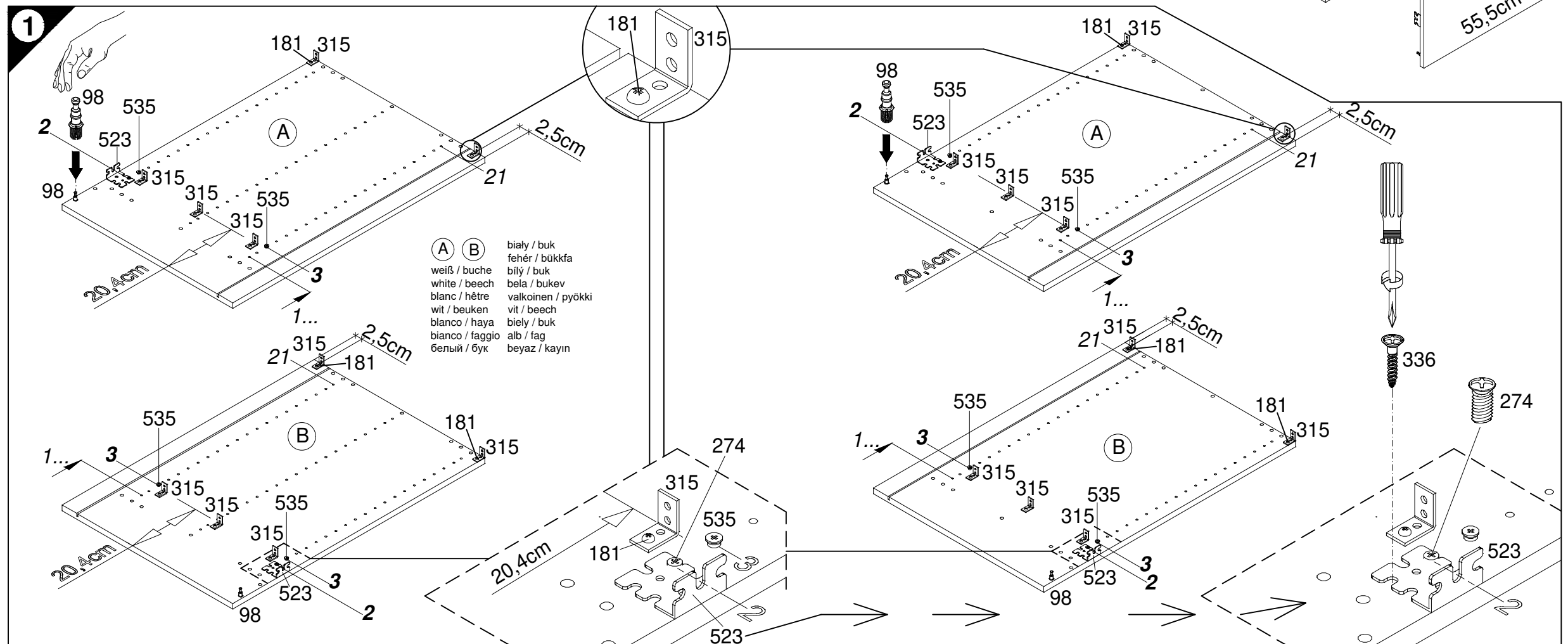
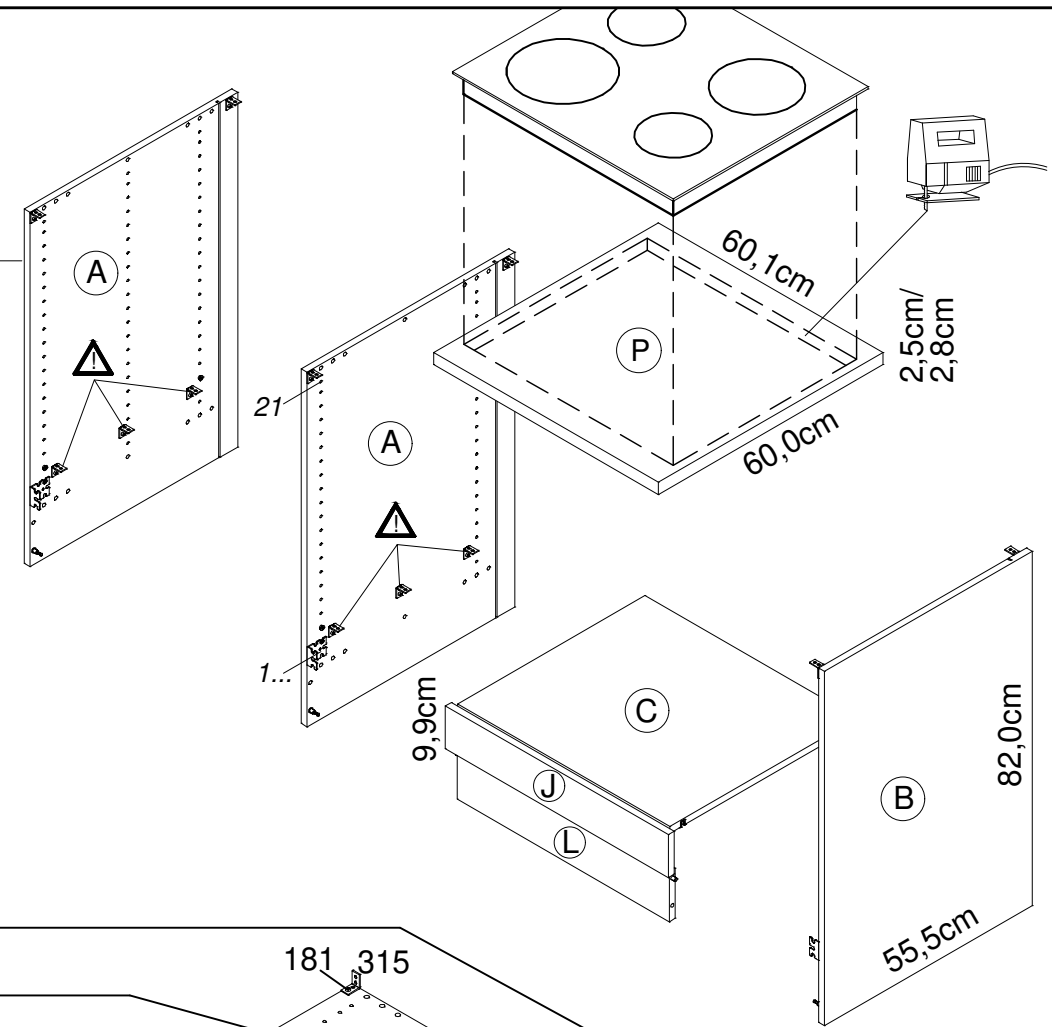

**Service-Hotline**  
01805-678101  
0,14€ pro Minute  
**++49 für Österreich**  
Auslandstarif pro Minute  
**service@jaka-bkl.de**  
voor Nederland en België  
**00800-40119350**  
**benelux@jaka-bkl.de**

Ersatzteile/Spare parts/pièces de rechange/Reserveonderdelen/Piezas de recambio/Ricambi/Запасные части/Części zamienne/pótkatárszek/Náhradní části/Nadomestni deli/varaosat/reservdelar/náhradné diely/Utilizați piese de schimb/Yedek parçalar

60cm	U(O)634-6	A  E981021	B  E981022	C  E950223	J  E940560	L  E970973	P  E441103
60cm	U(O)634-9	A  E961021	B  E961022	C  E950223	J  E940560	L  E970973	P  E540103
weiß/buche white/beech.....	U(O)634-9	A  E981021	B  E981022	C  E950223	J  E940560	L  E970973	P  E540103

1 → 2 → 3 ...

- 2x Nr.76
- 2x Nr.80
- 4x Nr.536
- 2x Nr.274
- 2x Nr.424
- 4x Nr.181

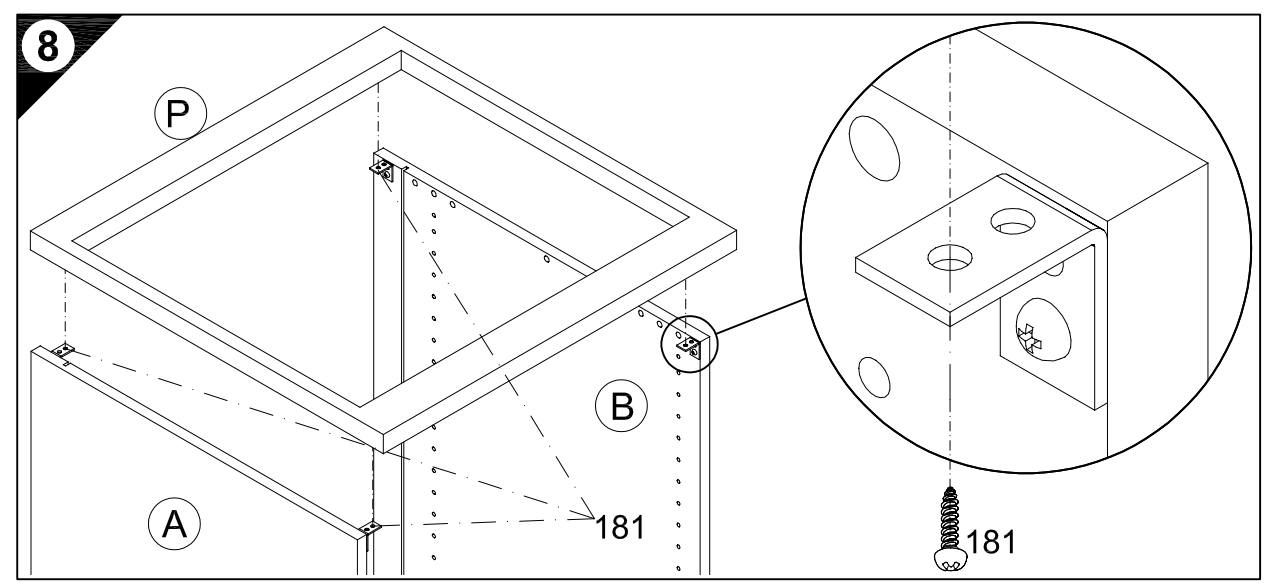
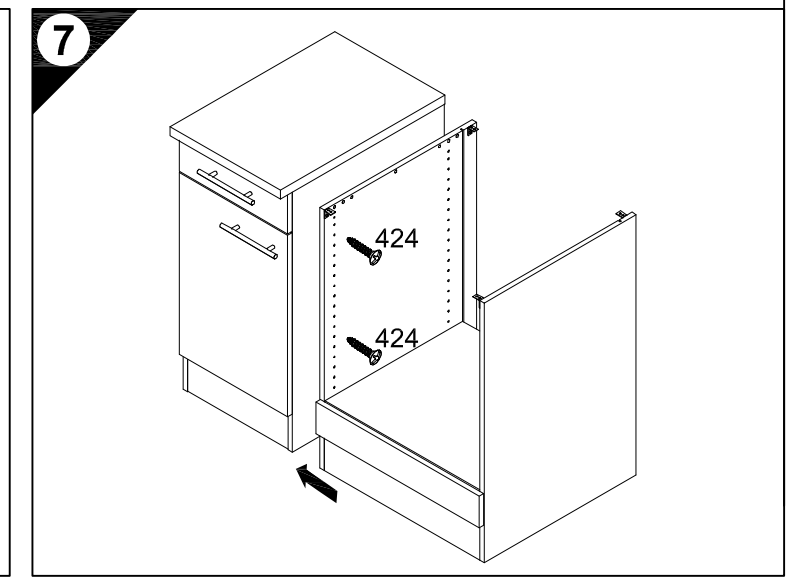
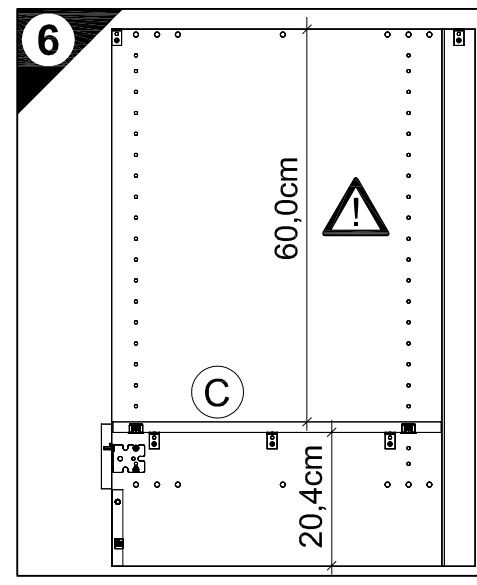
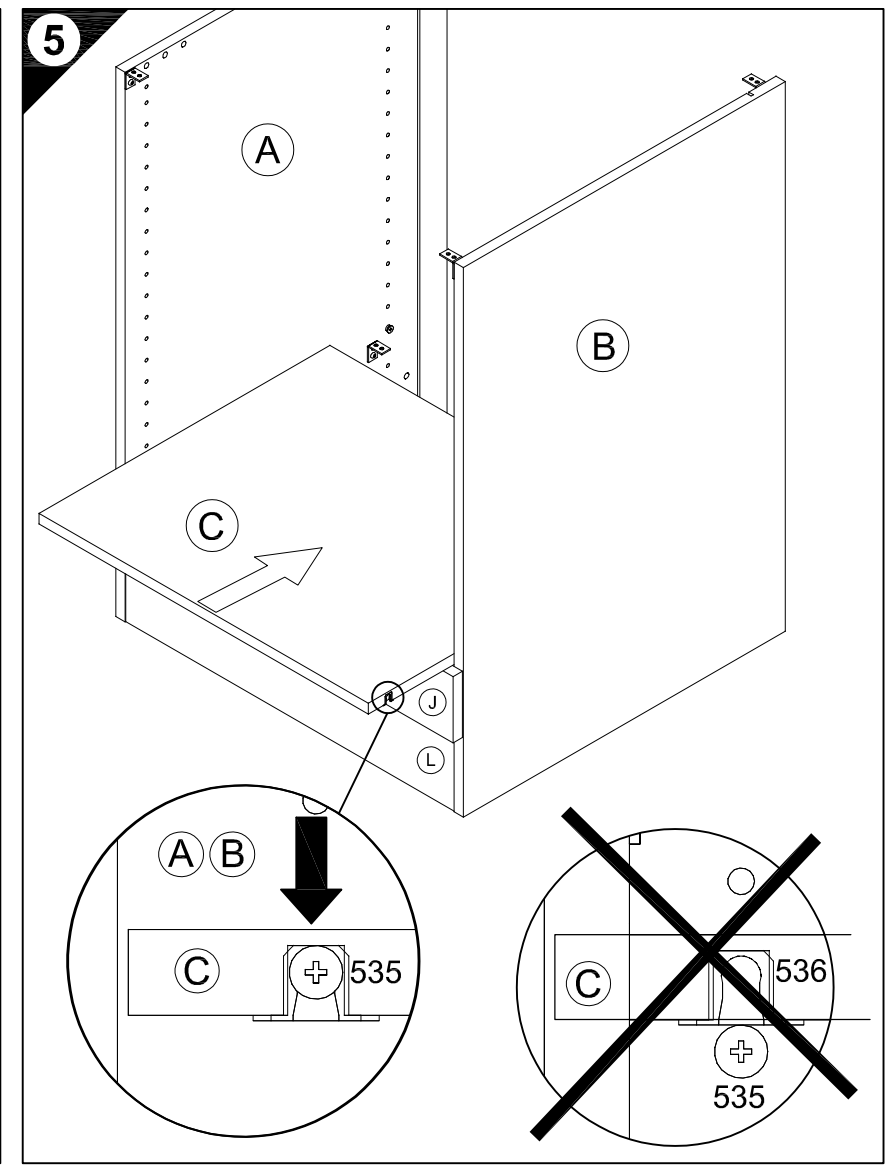
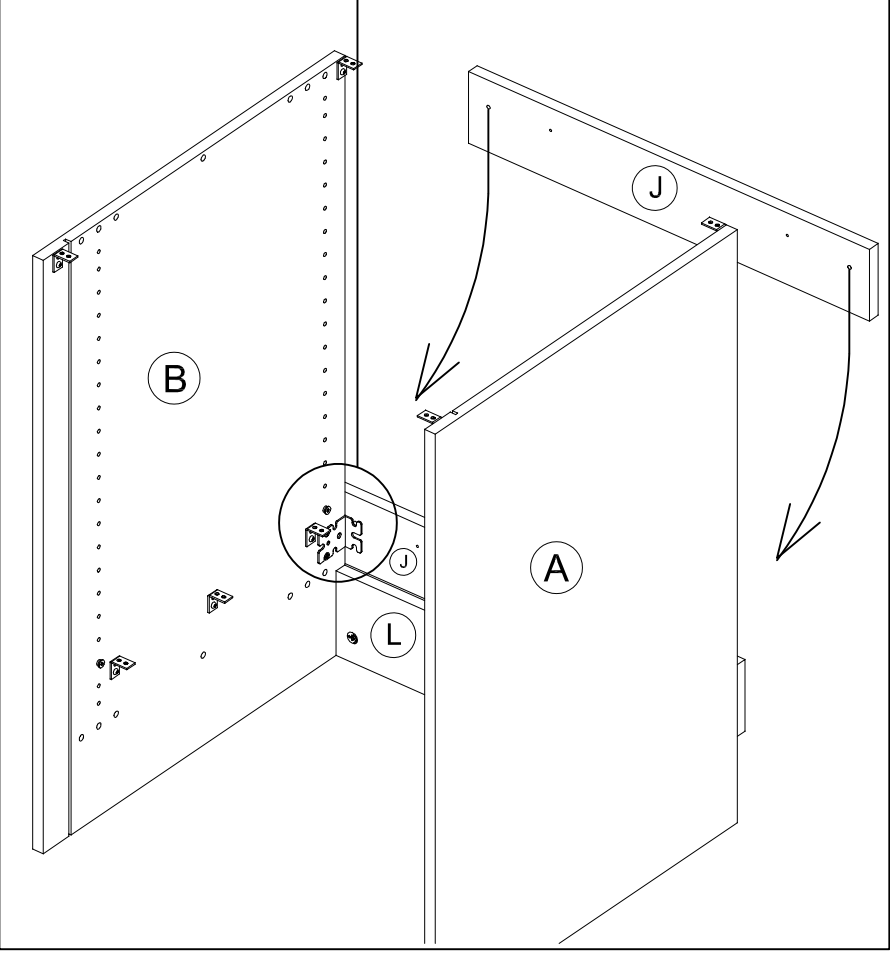
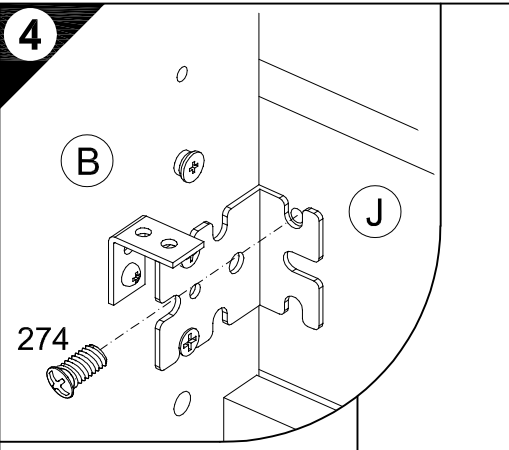
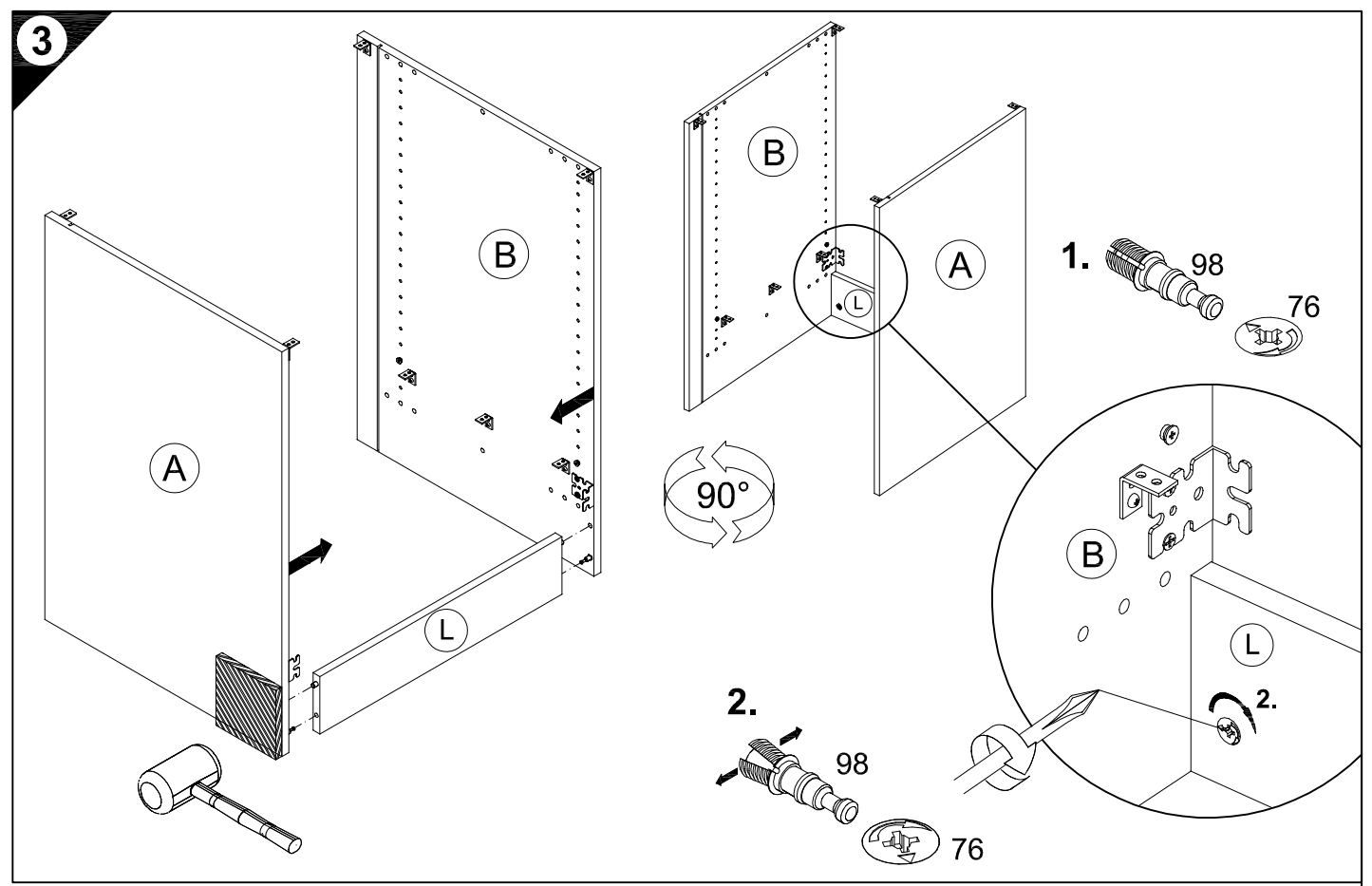
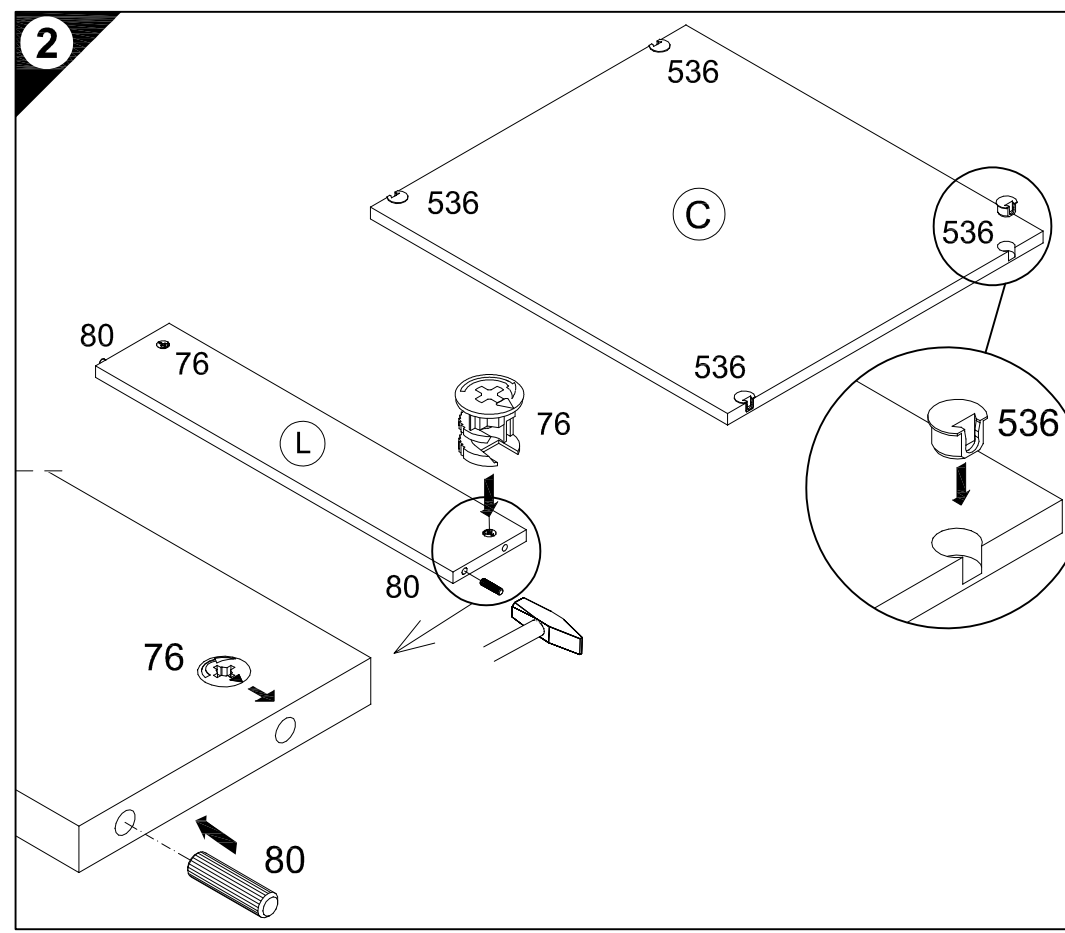

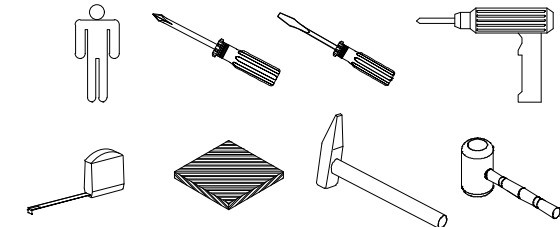

1 → 2 → 3 ...

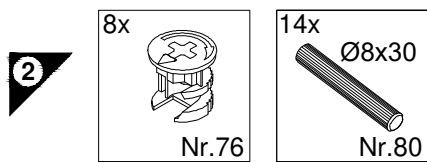
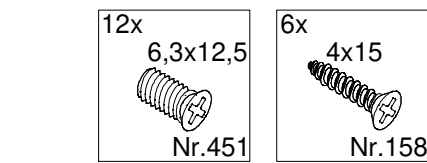
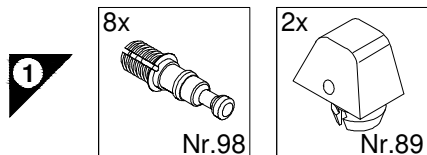

# Montageanleitung

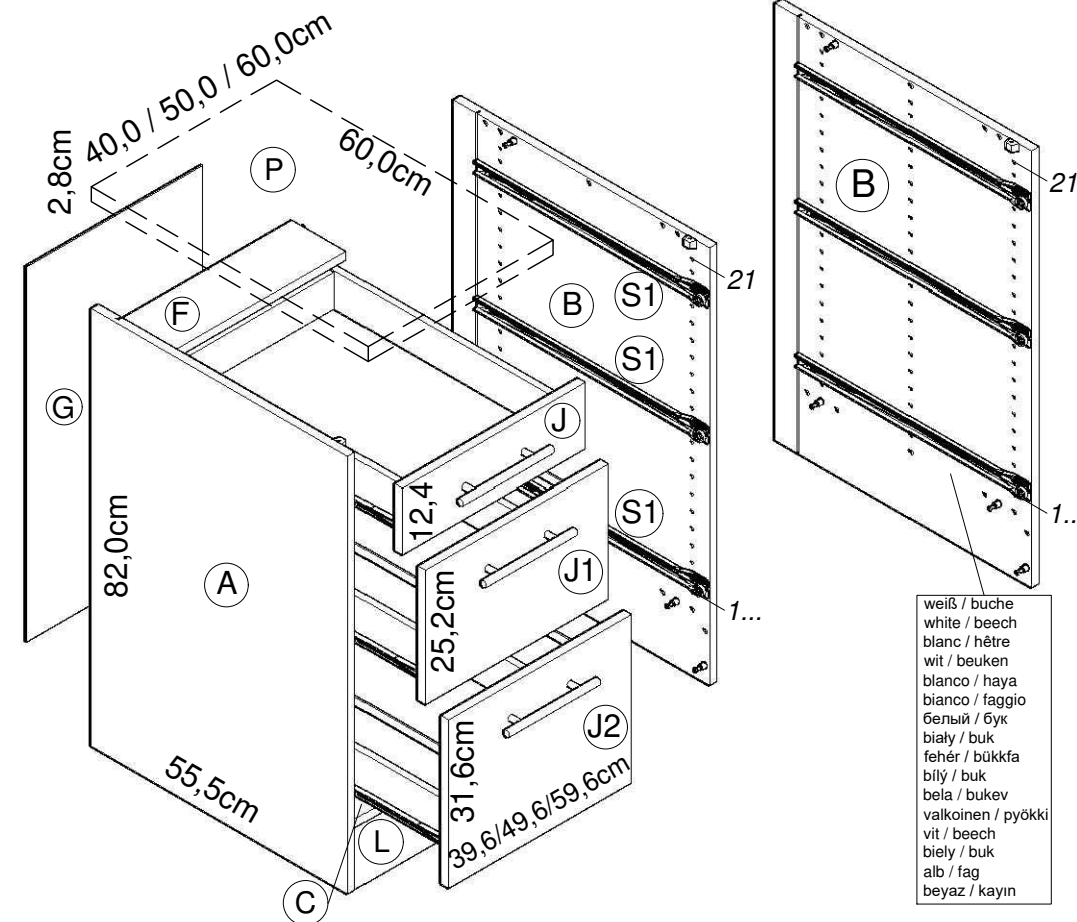
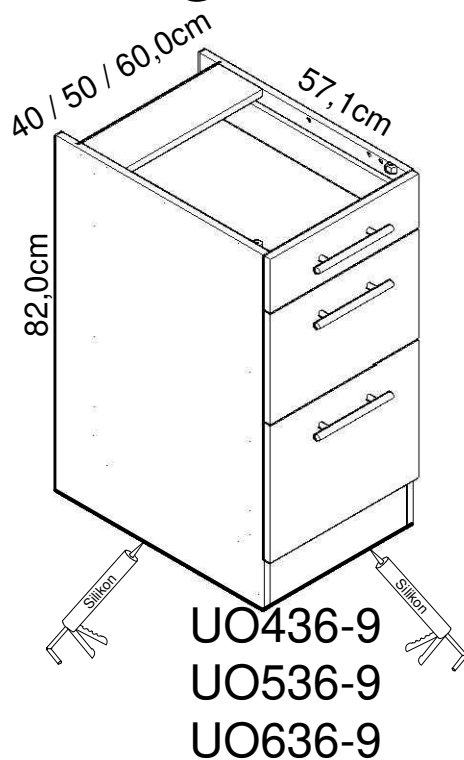
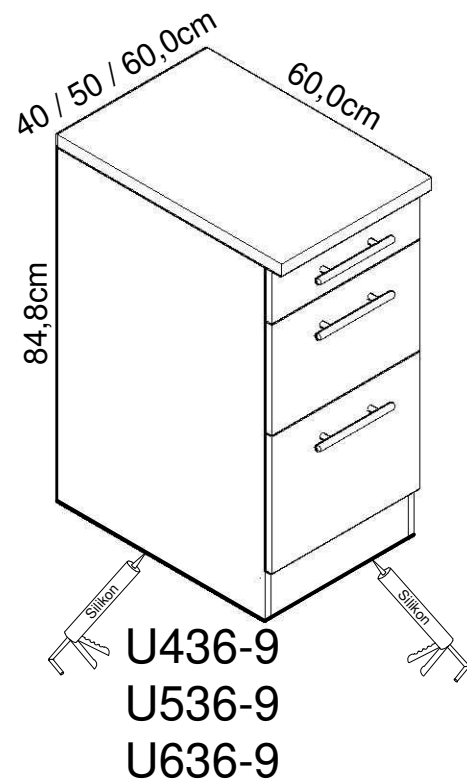

weiß / buche  
white / beech  
blanc / hêtre  
wit / beuken  
blanco / haya  
bianco / faggio  
белый / бук  
biały / buk  
fehér / bükkfa  
bílý / buk  
bela / bukev  
valkoinen / pyökki  
vit / beech  
biely / buk  
alb / fag  
beyaz / kayın

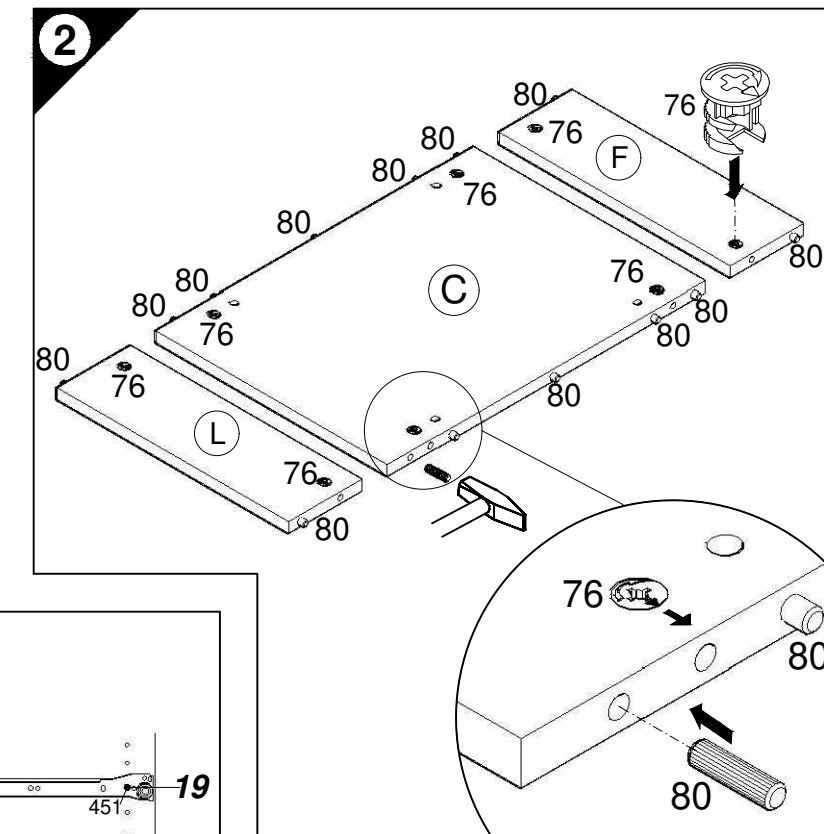
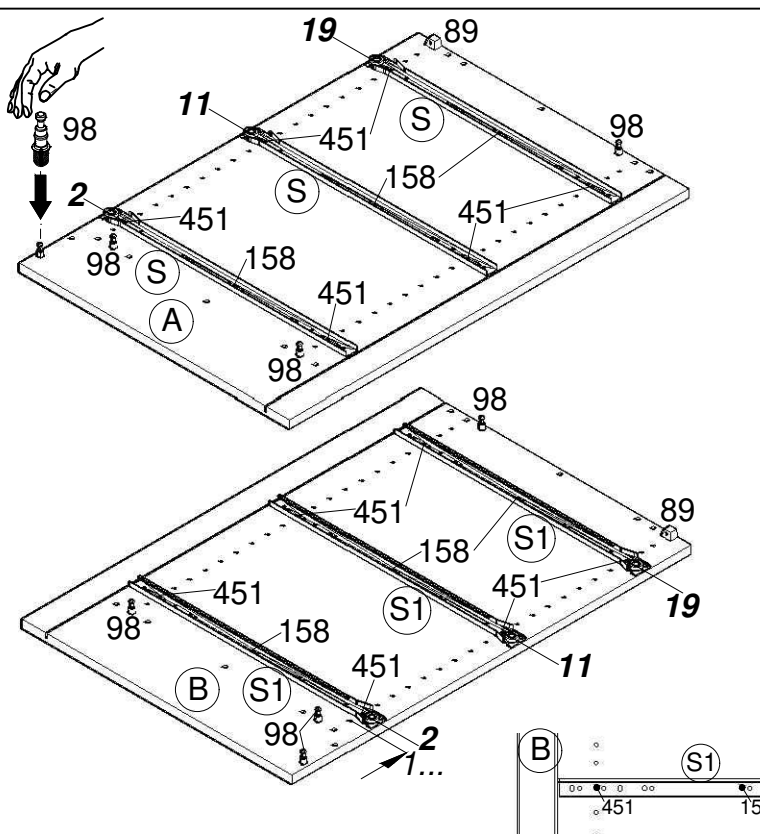
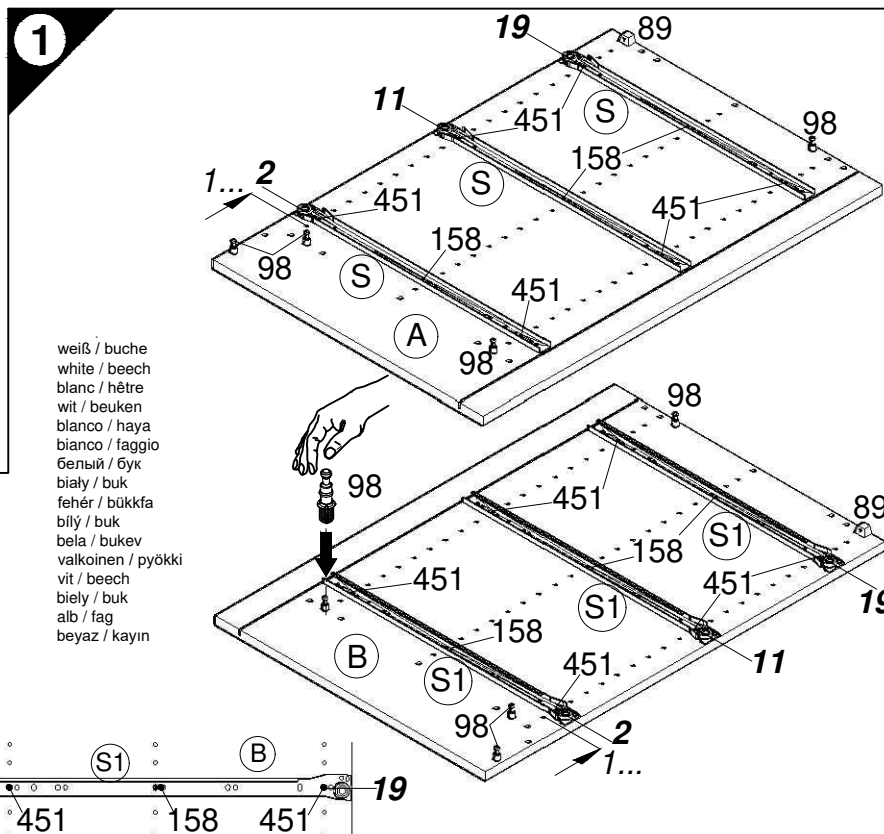

**Service-Hotline**  
01805-678101  
0,14€ pro Minute  
**++49 für Österreich**  
Auslandstarif pro Minute  
**service@jaka-bkl.de**  
voor Nederland en België  
00800-40119350  
**benelux@jaka-bkl.de**

Ersatzteile/Spare parts/pièces de rechange/Reserveonderdelen/Piezas de recambio/Ricambi/Запасные части/Części zamienne/pótalkatrészek/Náhradní části/Nadomestni deli/varaosat/reservdelar/náhradné diely/Utilizați piese de schimb/Yedek parçalar

40cm U(O)436-9 weiß/buche white/beech...	(A) E961021 (B) E961022 (C) E954215 (F) E970975 (G) E970010 (J) E940564 (J1) E940593 (J2) E940643 (L) E970975 (P) E540105 (S) E946155 (S1) E946155
50cm U(O)536-9 weiß/buche white/beech...	(A) E961021 (B) E961022 (C) E954224 (F) E970974 (G) E970117 (J) E940563 (J1) E940592 (J2) E940644 (L) E970974 (P) E540104 (S) E946155 (S1) E946155
60cm U(O)636-9 weiß/buche white/beech...	(A) E961021 (B) E961022 (C) E954223 (F) E970973 (G) E970116 (J) E940562 (J1) E940591 (J2) E940645 (L) E970973 (P) E540103 (S) E946155 (S1) E946155

1 → 2 → 3 ...

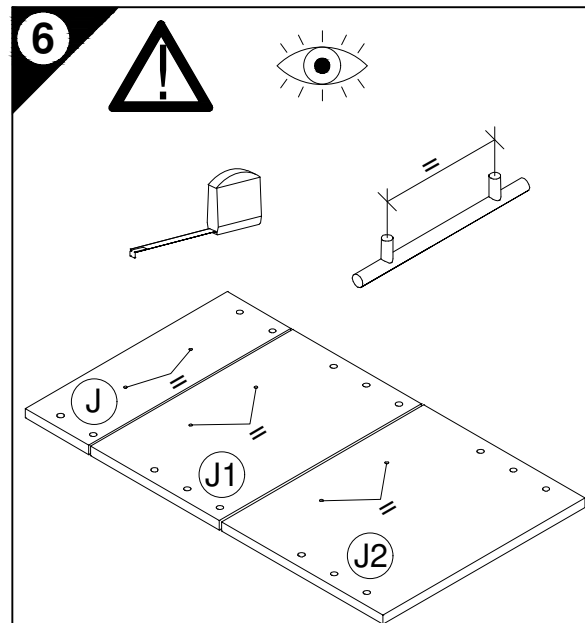
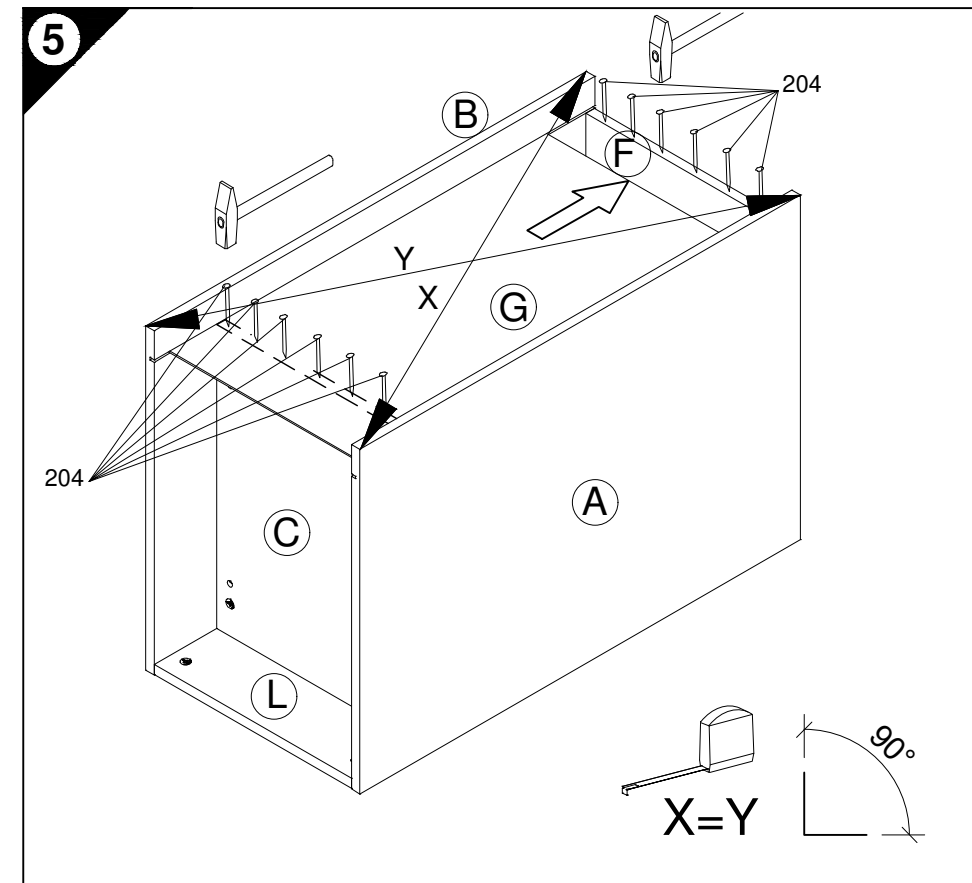
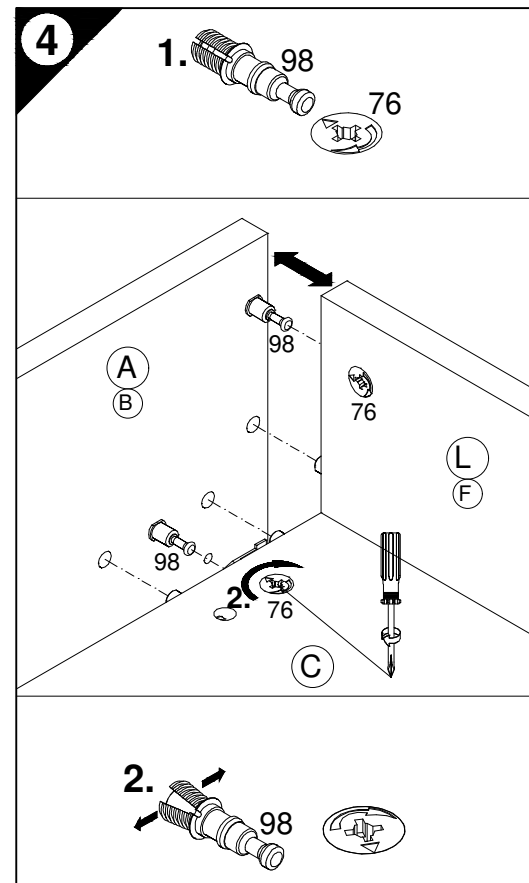
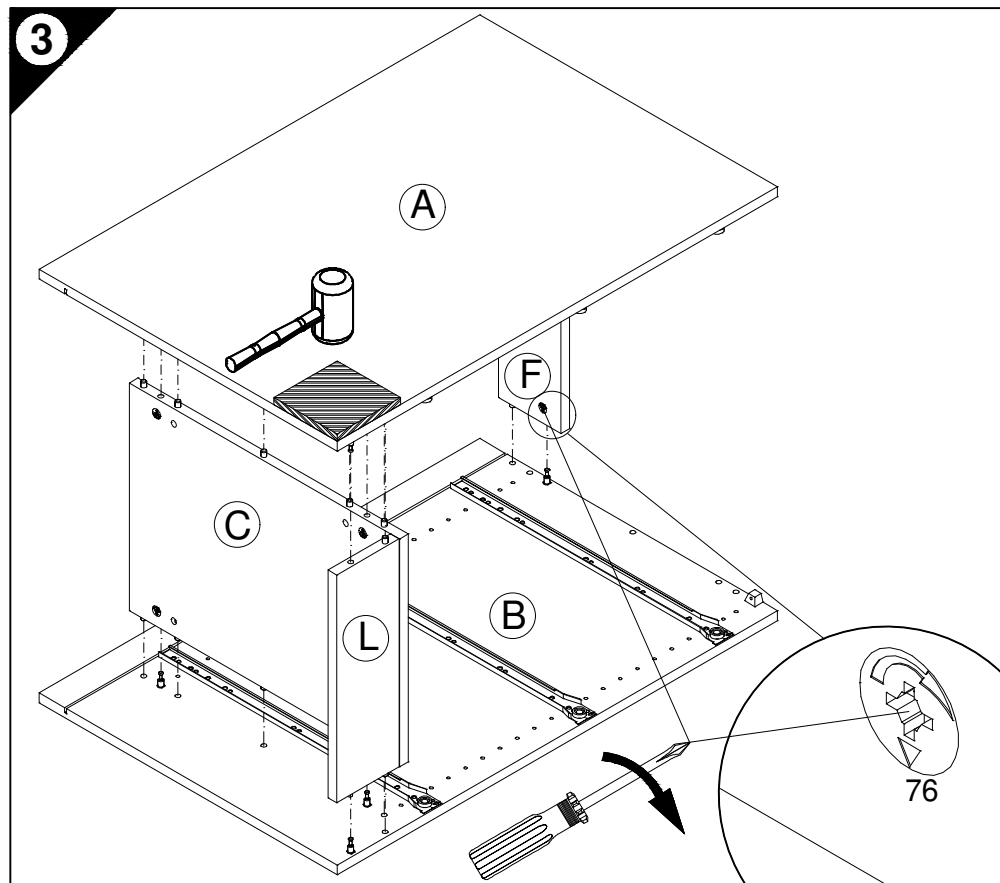
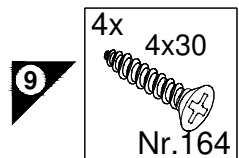
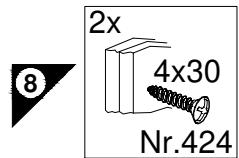
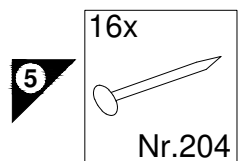

D Holzunterlage verwenden!  
Front andrücken, scharfen Bohrer verwenden und mit wenig Druck durchbohren!

GB Use a wooden base!  
Press front down, use sharp drill bit and, by applying slight pressure, drill a hole

F Utiliser un support en bois !  
Appuyer sur la façade, utiliser un foret bien affûté et percer en appliquant une faible pression !

NL Houten onderlegger gebruiken!  
Druk het front aan, gebruik een scherpe boor en oefen bij het boren weinig druk uit!

E ¡Utilizar una base de madera!  
¡Presionar el frente, utilizar una broca afilada y taladrar con poca presión!

I Utilizzare una base di legno!  
Appoggiare la facciata, utilizzare una punta di trapano affilata e trapanare esercitando solo una leggera pressione!

RUS Использовать деревянную подложку!  
Прижать фасад, использовать острое сверло и просверлить с незначительным давлением!

PL Używać podkładkę z drewna!  
Docisnąć front, użyć ostrego wiertła i przewiercić, używając małej siły nacisku!

H Alkalmazzon fa alátétet!  
Nyomja le az előlapot, használjon éles fúrót, és kis nyomással fúrja át!

CZ Použijte dřevěný podklad!  
Přitlačte čelo, použijte ostrý vrták a provrtejte pomocí malého tlaku!

SLO Uporabite leseno podlago!  
Pritisnite ličnico ter z ostrim svedrom in z majhnim pritiskom izvrtaite luknjo!

FIN Käytä puualustaa!  
Paina etulevy paikoilleen, käytä terävää poranterää ja poraa reikä vain kevyesti painamalla!

S Använd ett träunderlag!  
Tryck fronten mot underlaget, använd vass borr och borra igenom med ett lätt tryck!

SK Použite drevený podklad!  
Pritlačte front, použite ostrý vrták a prevrtajte miernym tlakom!

RO suport de lemn! Împingeți frontul, utilizați un burghiu ascuțit și perforați exercitând doar o presiune redusă!

TR Ahşap taban kullanın!  
Önden bastırın, keskin matkap ucu kullanın ve az basınç uygulayarak delin!

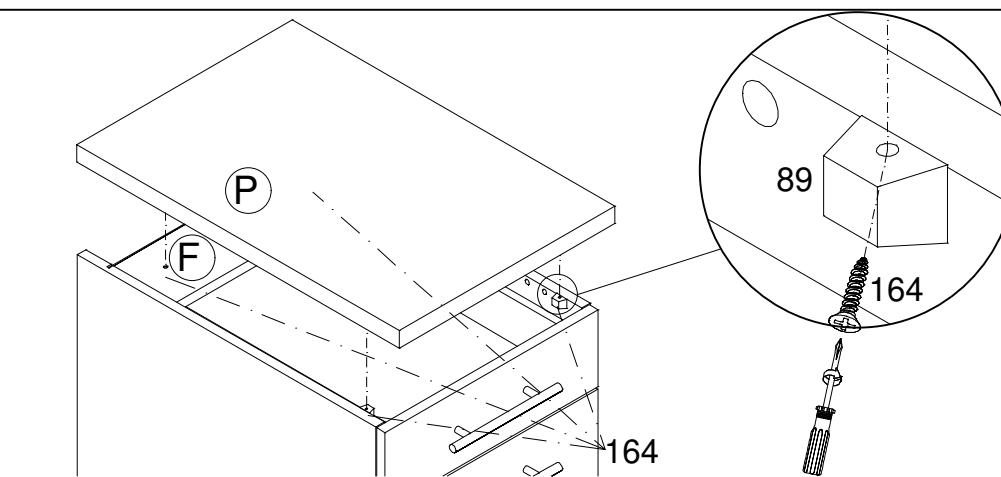
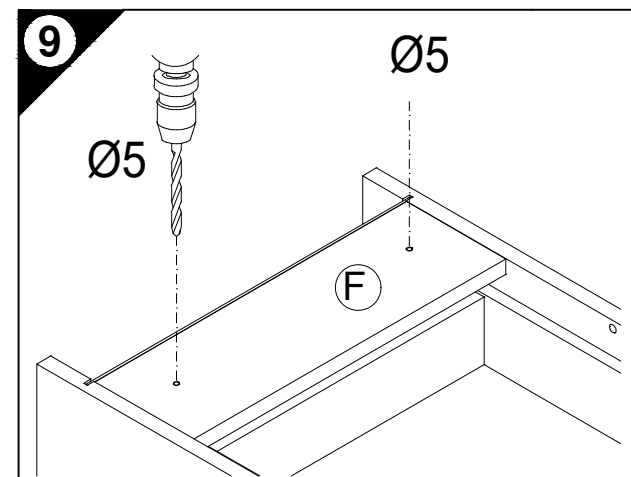
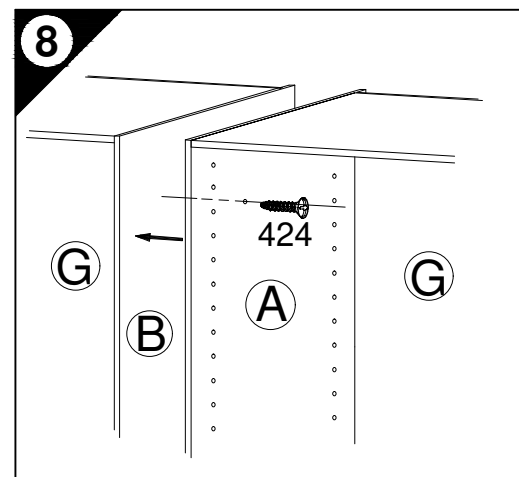
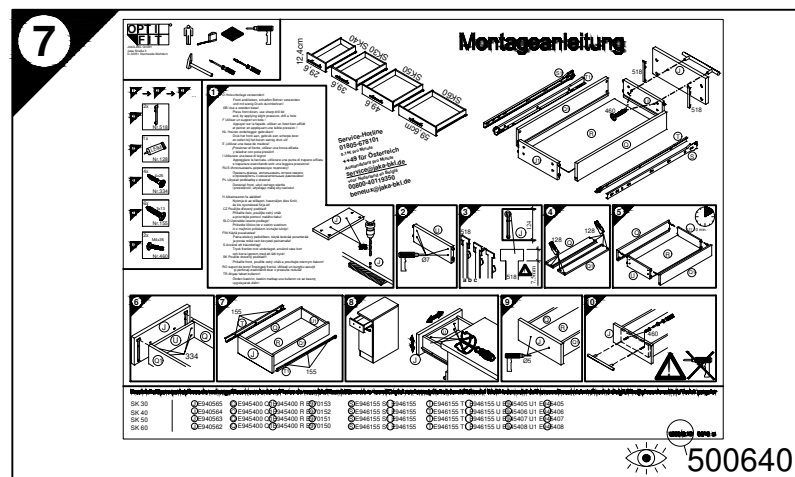
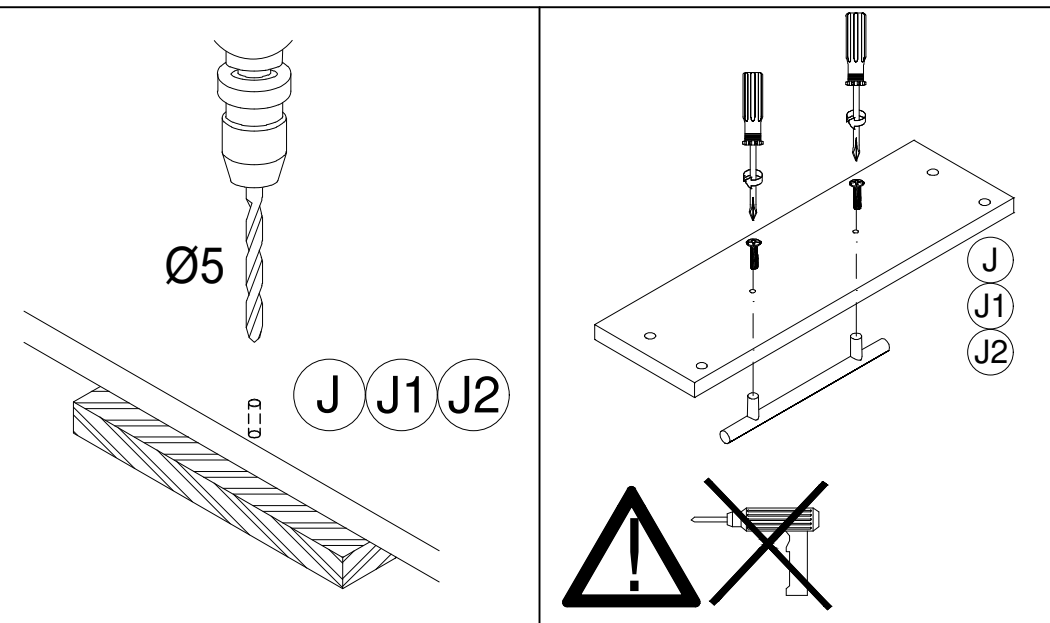

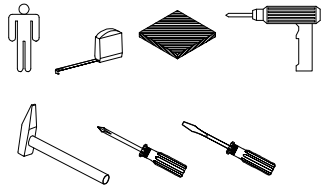

# Montageanleitung

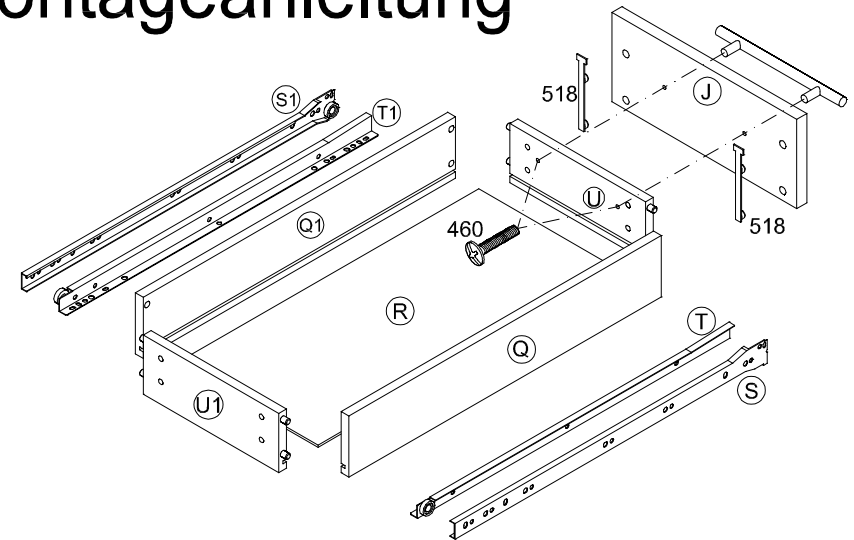
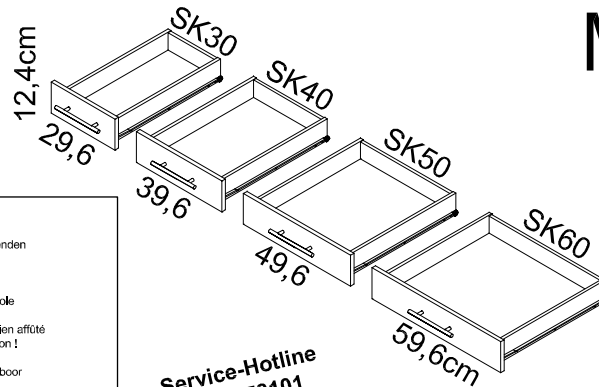

1 → 2 → 3 → ...

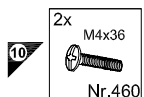
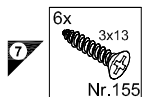
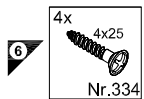
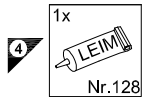
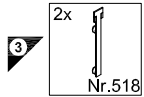

**1** D Holzunterlage verwenden!  
Front andrücken, scharfen Bohrer verwenden und mit wenig Druck durchbohren!  
Use a wooden base!  
Press front down, use sharp drill bit and, by applying slight pressure, drill a hole  
Utiliser un support en bois!  
Appuyer sur la façade, utiliser un foret bien affûté et percer en appliquant une faible pression!  
NL Houten onderlegger gebruiken!  
Druk het front aan, gebruik een scherpe boor en oefen bij het boren weinig druk uit!  
E rUtilizar una base de madera!  
rPresionar el frente, utilizar una broca afilada y taladrar con poca presión!  
I Utilizzare una base di legno!  
Appoggiare la facciata, utilizzare una punta di trapano affilata e trapanare esercitando solo una leggera pressione!  
RUS Использовать деревянную подложку!  
Прижать фасад, использовать острое сверло и проверлить с незначительным давлением!  
PL Używać podkładkę z drewna!  
Docisnąć front, użyć oстрого wiertła i przewiercić, używając małej siły nacisku!  
H Alkalimazson fa alátételt!  
Nyomja le az előlapot, használjon éles fűrőt, és kis nyomással fúrja át!  
CZ Použijte dřevěný podklad!  
Přitlačte čelo, použijte ostrý vrták a provrtajte pomocí malého tlaku!  
SLO Uporabite leseno podlagot!  
Pritisnite ličnico ter z ostrim svedom in z majhnim pritiskom izvrtajte luknjot.  
FIN Paina etulevyä paikalleen, käytä terävää poranterää ja poraa reikä vain kevyesti painamalla!  
S Använd ett träunderlag!  
Tryck fronten mot underlaget, använd vass borr och borra lgenom med ett lätt tryck!  
SK Použite drevený podklad!  
Pritlačte front, použite ostrý vrták a provrtajte miernym tlakom!  
RO suport de lemn! Împingeți frontul, utilizați un burghiu ascuțit și perforați exercitând doar o presiune redusă!  
TR Önden bastırın, keskin matkap ucu kullanın ve az basınç uygulayarak delin!

Service-Hotline  
01805-678101  
0,14€ pro Minute  
++49 für Österreich  
Auslandstarif pro Minute  
service@jaka-bkl.de  
voor Nederland en België  
00800-40119350  
benelux@jaka-bkl.de

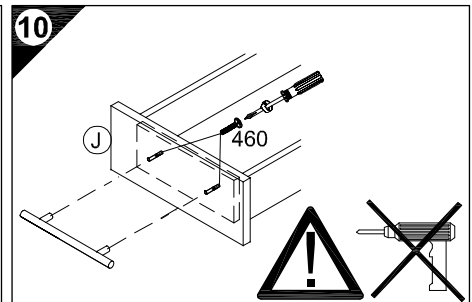
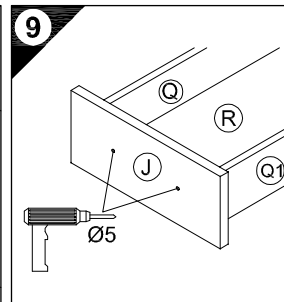
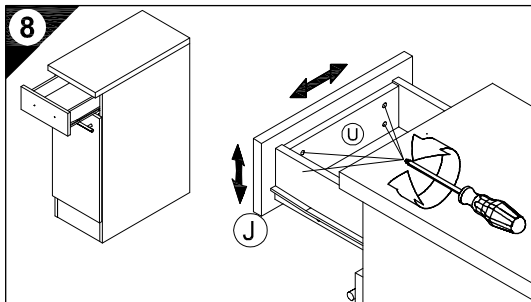
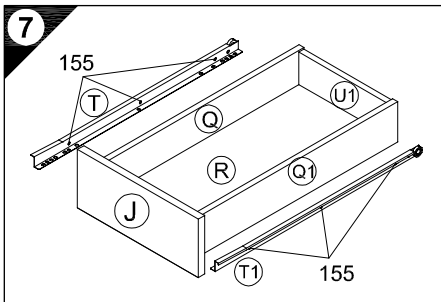
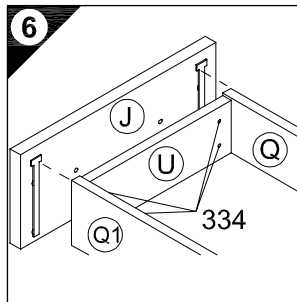
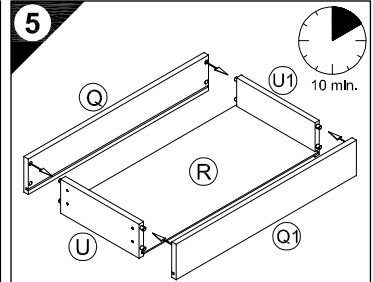
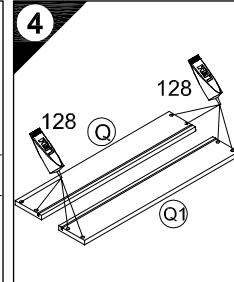
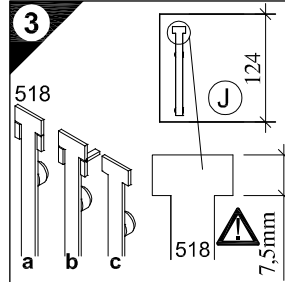
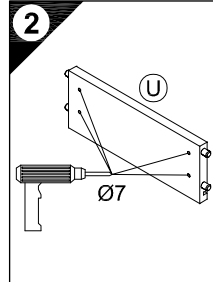
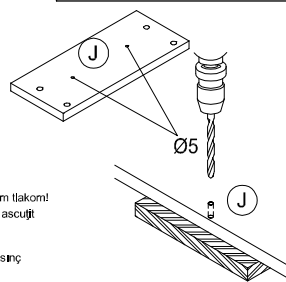

Ersatzteile/Spare parts/pièces de rechange/Reserveonderdelen/Piezas de recambio/Ricambi/Запасные части/Części zamienne/pótalkatrészek/Náhradní části/Nadomestni deli/varaosat/reservdelar/náhradné diely/Utilizați piese de schimb/Yedek parçalar

SK 30	J E940565	Q E945400	Q1 E945400	R E970153	S E946155	S1 E946155	T E946155	T1 E946155	U E945405	U1 E945405
SK 40	J E940564	Q E945400	Q1 E945400	R E970152	S E946155	S1 E946155	T E946155	T1 E946155	U E945406	U1 E945406
SK 50	J E940563	Q E945400	Q1 E945400	R E970151	S E946155	S1 E946155	T E946155	T1 E946155	U E945407	U1 E945407
SK 60	J E940562	Q E945400	Q1 E945400	R E970150	S E946155	S1 E946155	T E946155	T1 E946155	U E945408	U1 E945408

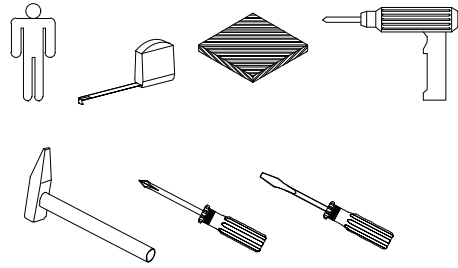

Service-Hotline  
01805-678101  
0,14€ pro Minute

++49 für Österreich  
Auslandstarif pro Minute  
service@jaka-bkl.de  
voor Nederland en België  
00800-40119350  
benelux@jaka-bkl.de

# Montageanleitung

1 → 2 → 3 ...

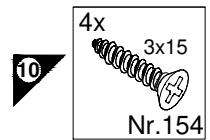
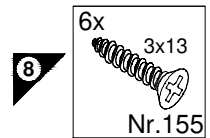
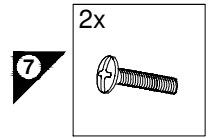
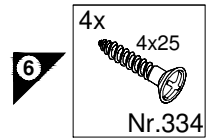
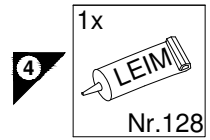
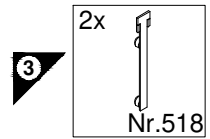

**1**

D Holzunterlage verwenden!  
Front andrücken, scharfen Bohrer verwenden und mit wenig Druck durchbohren!

GB Use a wooden base!  
Press front down, use sharp drill bit and, by applying slight pressure, drill a hole

F Utiliser un support en bois!  
Appuyer sur la façade, utiliser un foret bien affûté et percer en appliquant une faible pression!

NL Houten onderlegger gebruiken!  
Druk het front aan, gebruik een scherpe boor en oefen bij het boren weinig druk uit!

E Utilizar una base de madera!  
Presionar el frente, utilizar una broca afilada y taladrar con poca presión!

I Utilizzare una base di legno!  
Appoggiare la facciata, utilizzare una punta di trapano affilata e trapanare esercitando solo una leggera pressione!

RUS Использовать деревянную подложку!  
Прижать фасад, использовать острое сверло и просверлить с незначительным давлением!

PL Używać podkładkę z drewna!  
Docisnąć front, użyć ostrego wiertła i przewiercić, używając małej siły nacisku!

H Alkalmazzon fa alátétet!  
Nyomja le az előlapot, használjon éles fúrót, és kis nyomással fúrja át!

CZ Použijte dřevěný podklad!  
Přitlačte čelo, použijte ostrý vrták a provrtajte pomocí malého tlaku!

SLO Uporabite leseno podlago!  
Pritisnite ličnico ter z ostrim svedrom in z majhnim pritiskom izvrtajte luknjo!

FIN Käytä puualustaa!  
Paina etulevy paikoilleen, käytä terävää poranterää ja poraa reikä vain kevyesti painamalla!

S Använd ett träunderlag!  
Tryck fronten mot underlaget, använd vass borr och borra igenom med ett lätt tryck!

SK Použite drevený podklad!  
Pritlačte front, použite ostrý vrták a prevrtajte miernym tlakom!

RO suport de lemn! Împingeți frontul, utilizați un burghiu ascuțit și perforați exercitând doar o presiune redusă!

TR Ahşap taban kullanın!  
Önden bastırın, keskin matkap ucu kullanın ve az basınç uygulayarak delin!

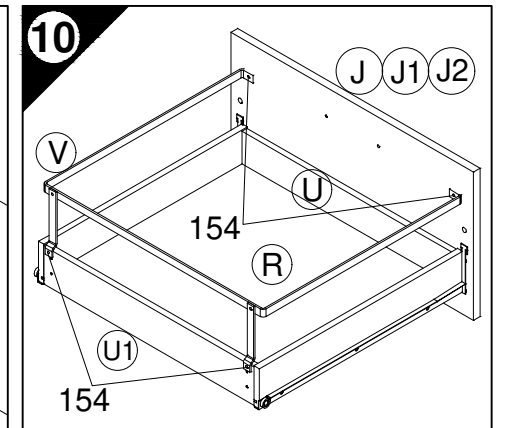
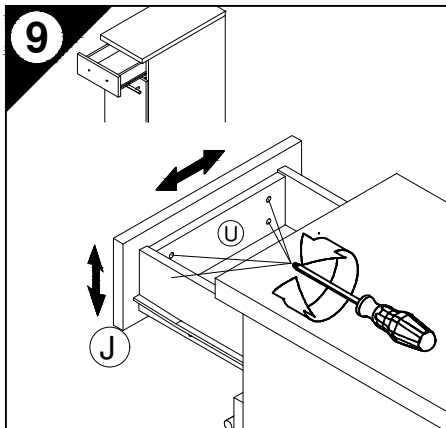
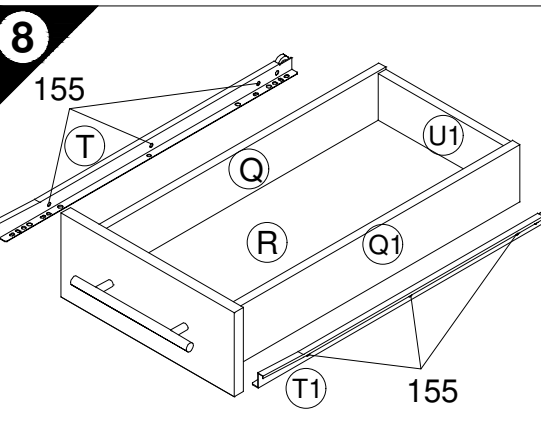
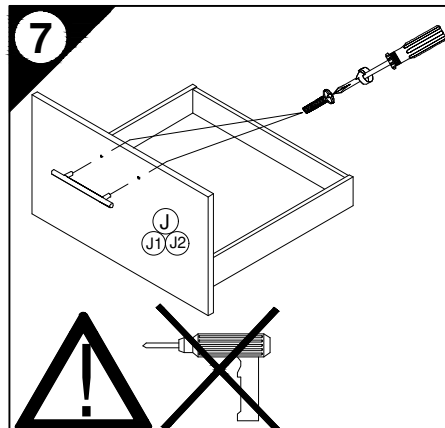
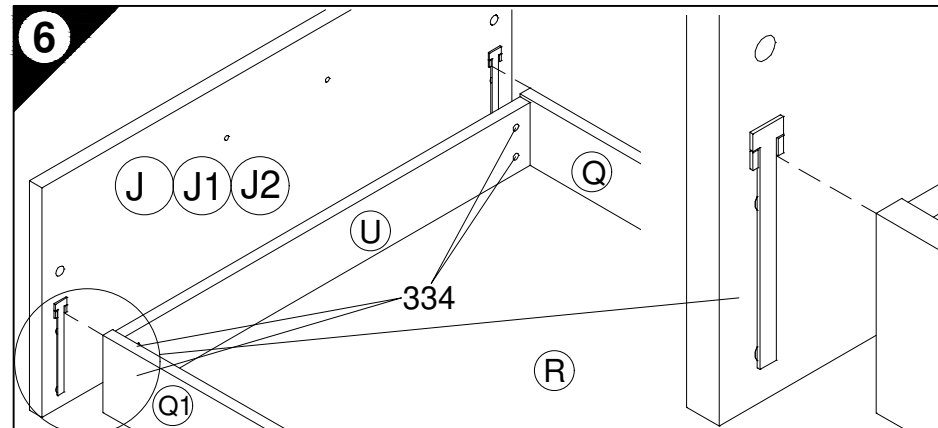
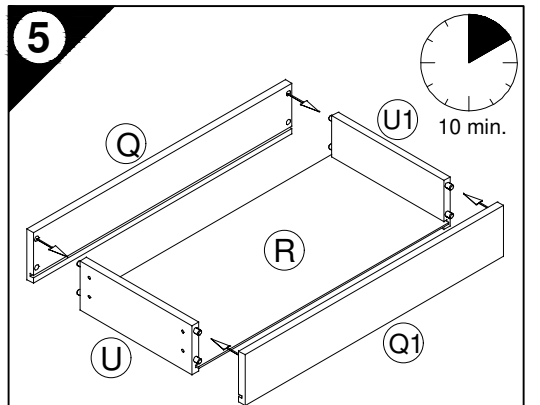
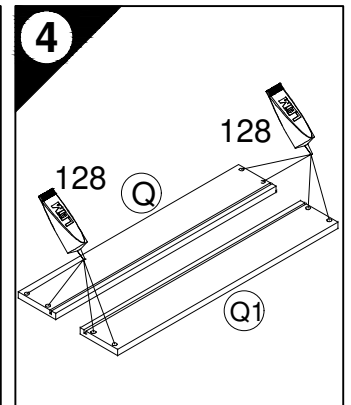
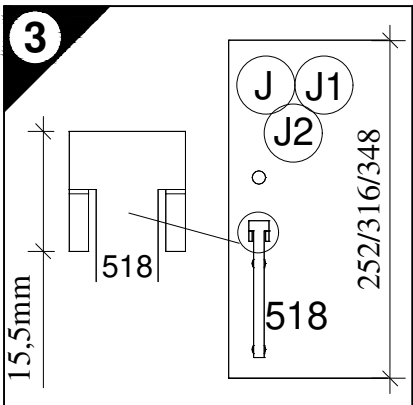
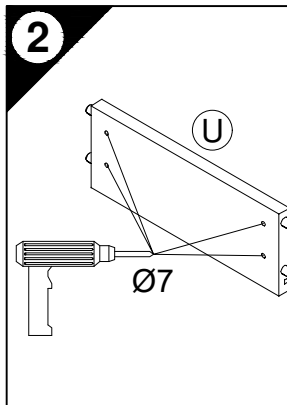
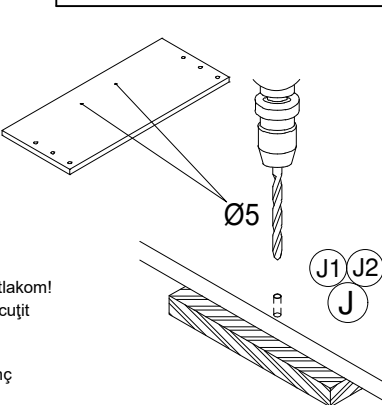
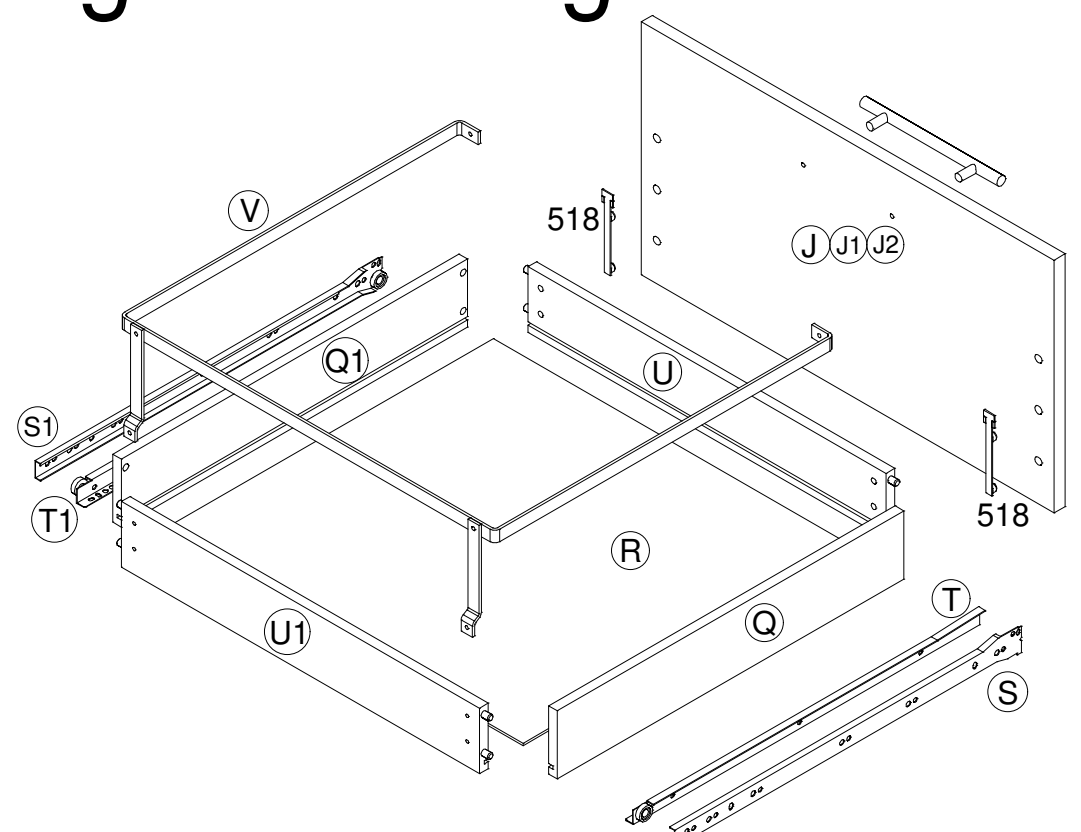
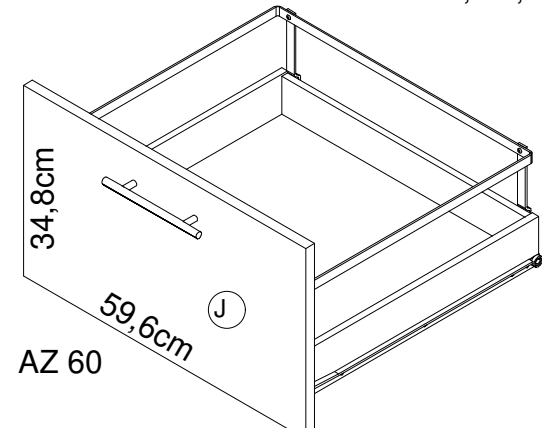
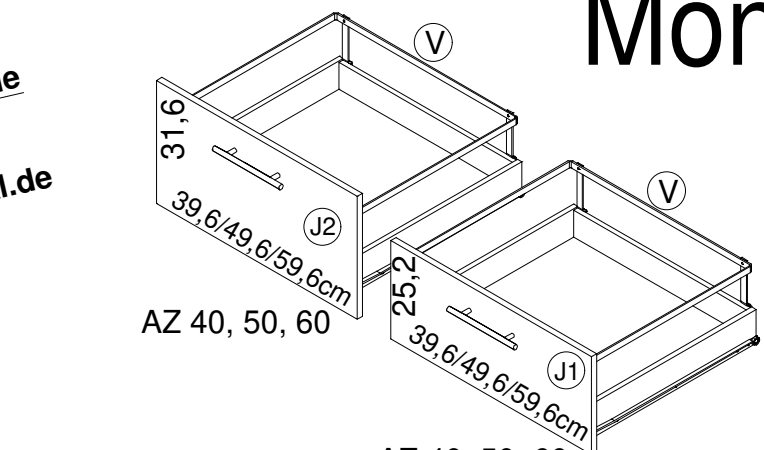

Ersatzteile/Spare parts/pièces de rechange/Reserveonderdelen/Piezas de recambio/Ricambi/Запасные части/Części zamienne/pótalkatrészek/Náhradní části/Nadomestni deli/varaosat/reservdelar/náhradné diely/Utilizați piese de schimb/Yedek parçalar

AZ 60	J E940666	J1 E940591	J2 E940645	Q E945400	Q1 E945400	R E970150	S E946155	S1 E946155	T E946155	T1 E946155	U E945408	U1 E945408	V E446167
AZ 50	J1 E940592	J2 E940644	Q E945400	Q1 E945400	R E970151	S E946155	S1 E946155	T E946155	T1 E946155	U E945407	U1 E945407	V E446166	
AZ 40	J1 E940593	J2 E940643	Q E945400	Q1 E945400	R E970152	S E946155	S1 E946155	T E946155	T1 E946155	U E945406	U1 E945406	V E446165	

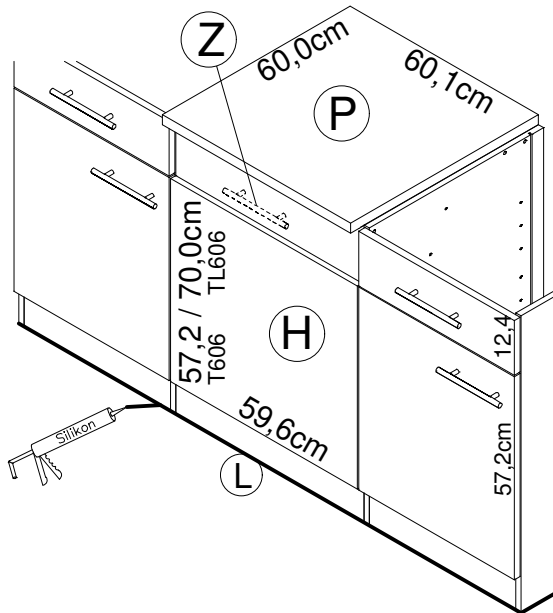
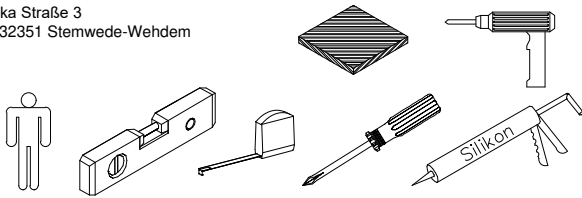

# Montageanleitung

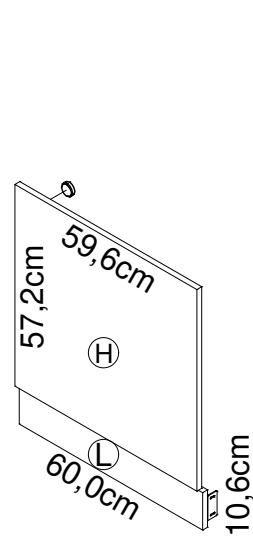

T606-6  
T606-9

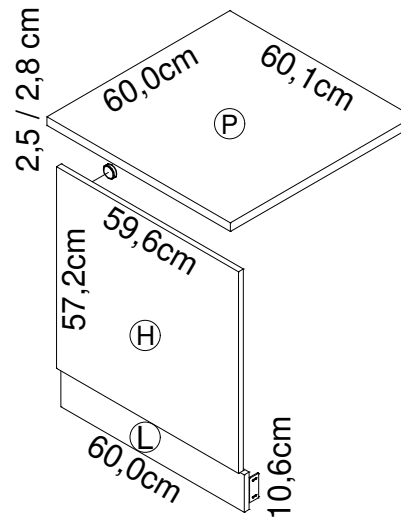

T606APL-6  
T606APL-9

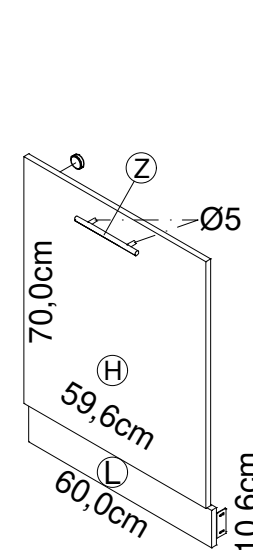

TL606-9

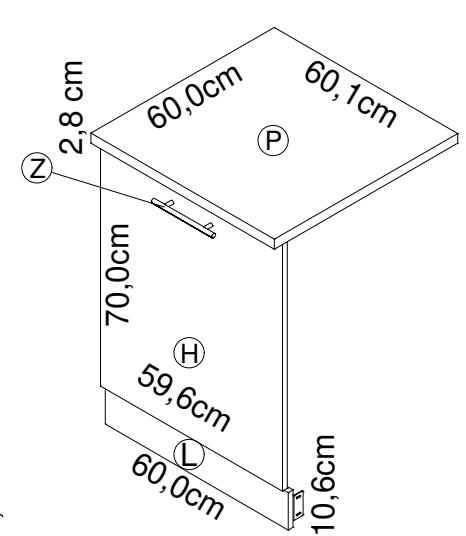

TL606APL-9

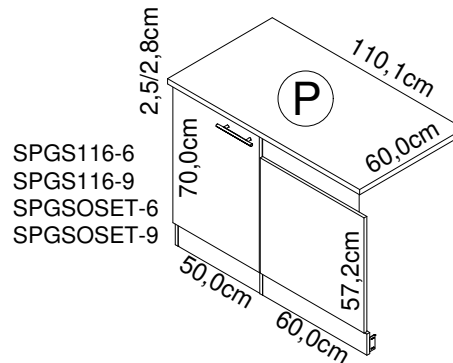

SPGS116-6  
SPGS116-9  
SPGSOSET-6  
SPGSOSET-9

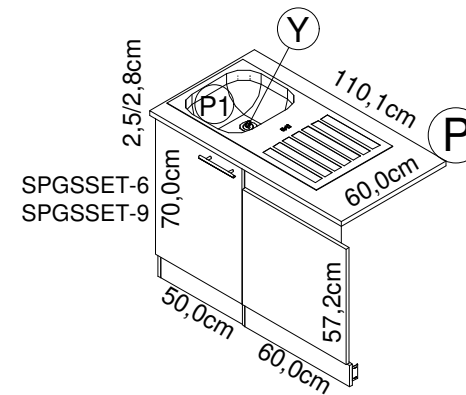

SPGSSET-6  
SPGSSET-9

**Service-Hotline**  
01805-678101  
0,14€ pro Min.  
**+49 für Österreich**  
Auslandstarif pro Min.  
**service@jaka-bkl.de**  
voor Nederland en België  
**00800-40119350**  
**benelux@jaka-bkl.de**

Ersatzteile/Spare parts/pièces de rechange/Reserveonderdelen/Piezas de recambio/Ricambi/Запасные части/Części zamienne/  
półtaktrészek/Náhradní části/Nadomestni deli/varaosat/reservdelar/náhradné diely/Utilizați piese de schimb/Yedek parçalar

T 606-6	(H) E980611	(L) E946048	
T 606-9	(H) E940611	(L) E946048	
T 606APL-6	(H) E980611	(L) E946048	(P) E441103
T 606APL-9	(H) E940611	(L) E946048	(P) E540103

TL 606-9	(H) E940621	(L) E946048	(Z) E447100
TL 606APL-9	(H) E940621	(L) E946048	(P) E540103 (Z) E447100
SPGS...-6	(P) E441100	(P1) E448292	(Y) E446500
SPGS...-9	(P) E540100	(P1) E448292	(Y) E446500

1 → 2 → 3 ...

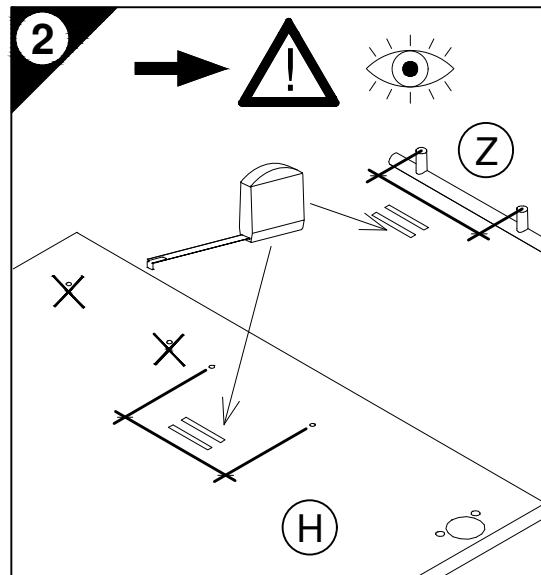
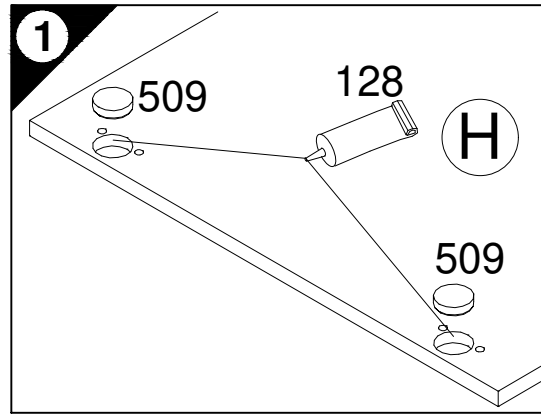
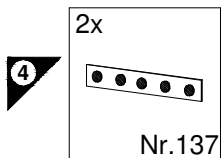
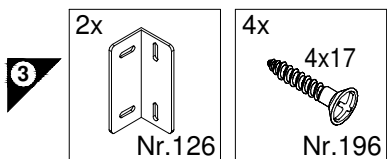
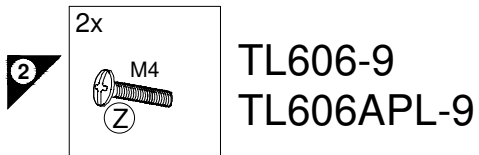
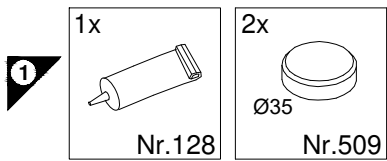

- D Holzunterlage verwenden!  
Front andrücken, scharfen Bohrer verwenden und mit wenig Druck durchbohren!
- GB Use a wooden base!  
Press front down, use sharp drill bit and, by applying slight pressure, drill a hole
- F Utiliser un support en bois !  
Appuyer sur la façade, utiliser un foret bien affûté et percer en appliquant une faible pression !
- NL Houten onderlegger gebruiken!  
Druk het front aan, gebruik een scherpe boor en oefen bij het boren weinig druk uit!
- E ¡Utilizar una base de madera!  
¡Presionar el frente, utilizar una broca afilada y taladrar con poca presión!
- I Utilizzare una base di legno! Appoggiare la facciata, utilizzare una punta di trapano affilata e trapanare esercitando solo una leggera pressione!
- RUS Использовать деревянную подложку!  
Прижать фасад, использовать острое сверло и просверлить с незначительным давлением!
- PL Używać podkładkę z drewna!  
Docisnąć front, użyć oстрого wiertła i przewiercić, używając małej siły nacisku!
- H Alkalmazzon fa alátét!  
Nyomja le az előlapot, használjon éles fűrőt, és kis nyomással fúrja át!
- CZ Použijte dřevěný podklad!  
Přitlačte čelo, použijte ostrý vrták a prověřte pomocí malého tlaku!
- SLO Uporabite leseno podlago!  
Pritisnite ličnico ter z ostrim svedrom in z majhnim pritiskom izvrtajte luknjo!
- FIN Käytä puualustaa!  
Paina etulevy paikoilleen, käytä terävää poranterää ja poraa reikä vain kevyesti painamalla!
- S Använd ett träunderlag!  
Tryck fronten mot underlaget, använd vass borrh och borra igenom med ett lätt tryck!
- SK Použite drevený podklad!!  
Pritlačte front, použite ostrý vrták a prevrtajte miernym tlakom!
- RO suport de lemn! Împingeți frontul, utilizați un burghiu ascuțit și perforați exercitând doar o presiune redusă!
- TR Ahşap taban kullanın!  
Önden bastırın, keskin matkap ucu kullanın ve az basınç uygulayarak delin!

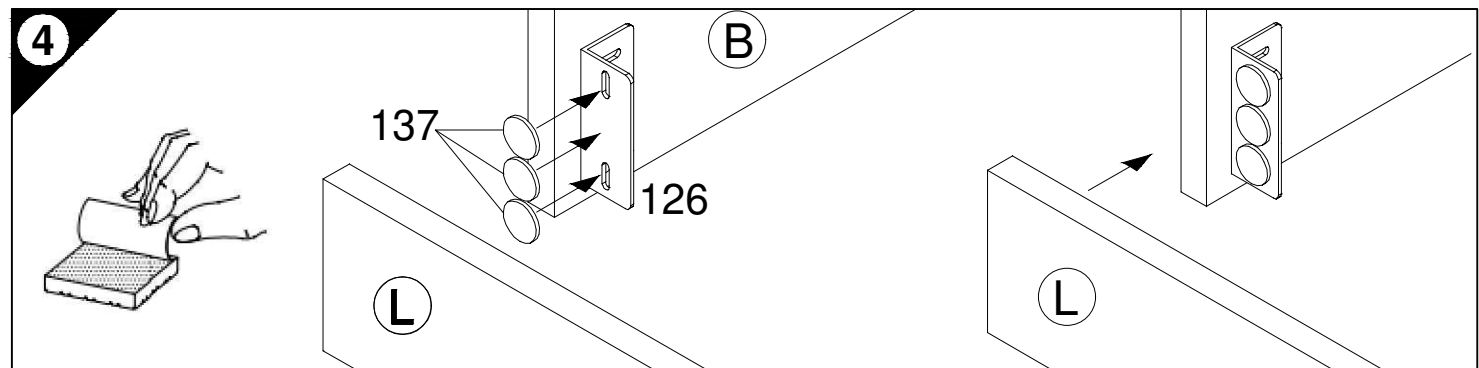
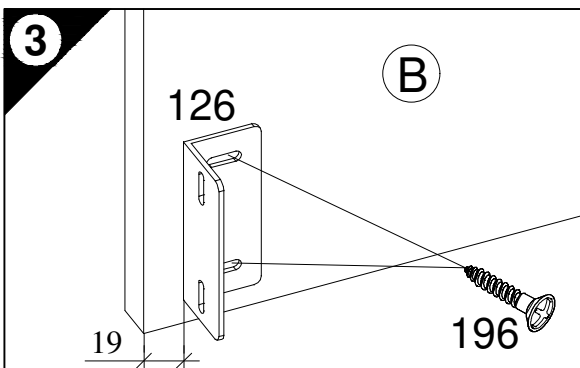
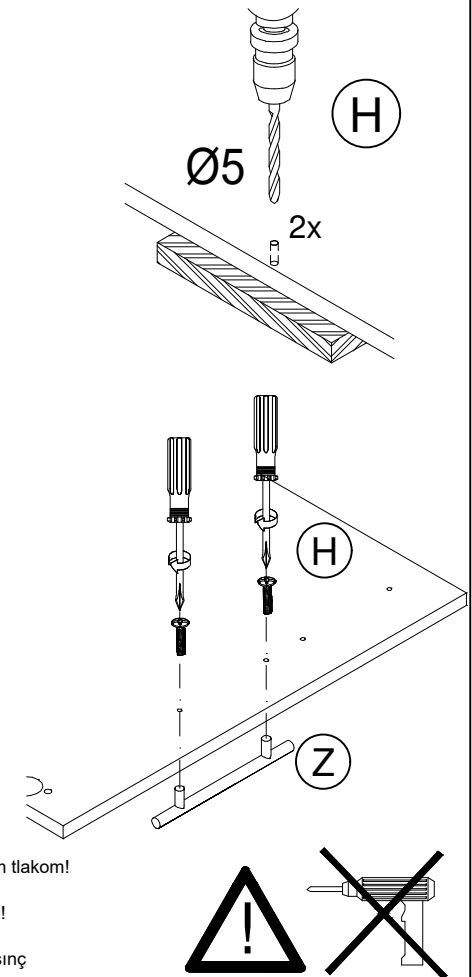



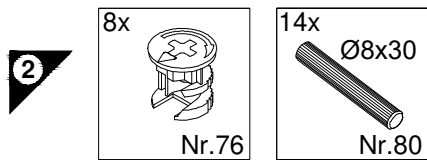
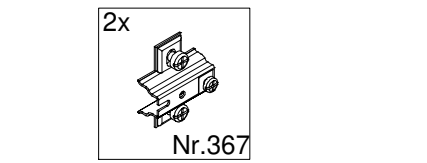
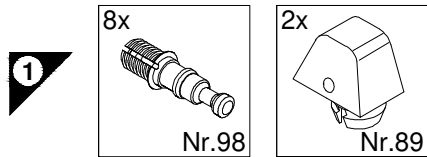
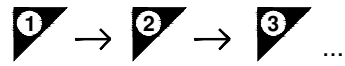
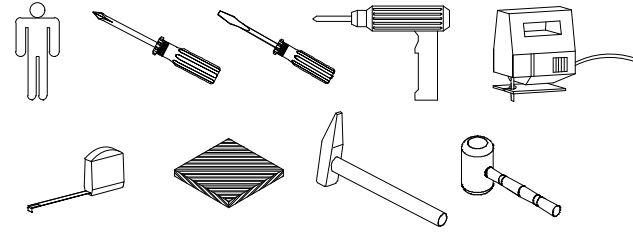

SPGS116-9  
SPGS116-6  
SPGSOSET-9  
SPGSOSET-6

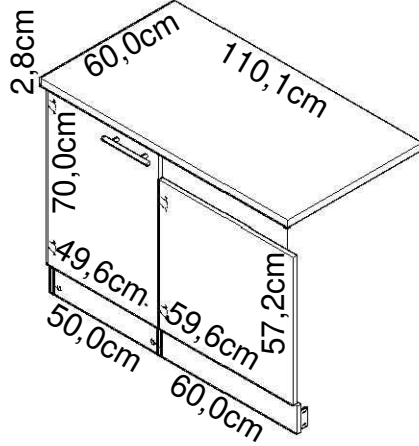

# Montageanleitung

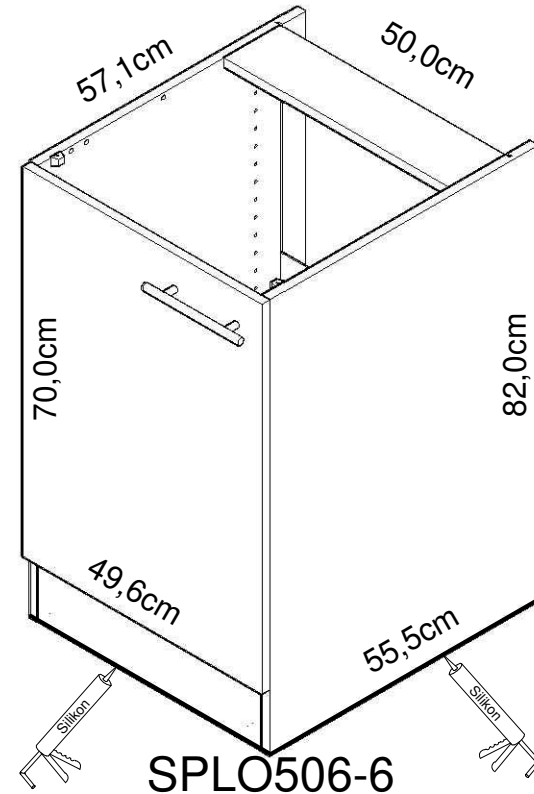

weiß / buche  
white / beech  
blanc / hêtre  
wit / beuken  
blanco / haya  
белый / бук  
biały / buk  
fehér / bükkfa  
bílý / buk  
bela / bukev  
valkoinen / pyökki  
vit / beech  
biely / buk  
alb / fag  
beyaz / kayın

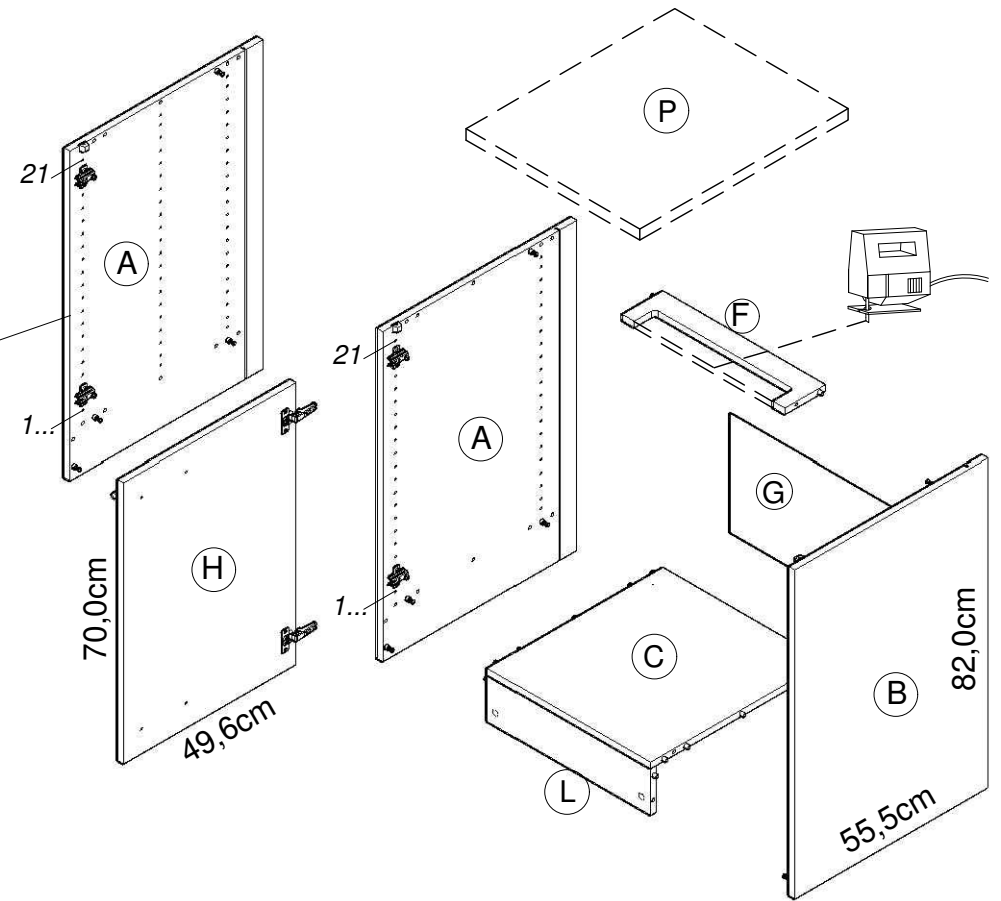

**Service-Hotline**  
01805-678101  
0,14€ pro Minute  
**++49 für Österreich**  
Auslandstarif pro Minute  
**service@jaka-bkl.de**  
voor Nederland en België  
**00800-40119350**  
**benelux@jaka-bkl.de**

SPLO506-6  
SPLO506-9

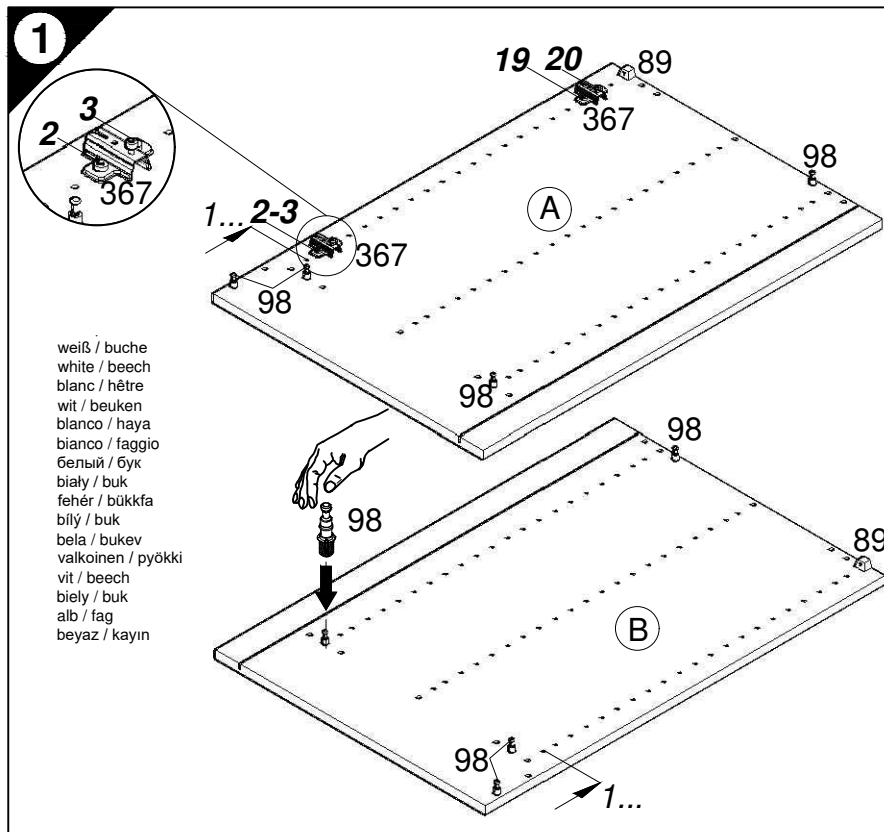

weiß / buche  
white / beech  
blanc / hêtre  
wit / beuken  
blanco / haya  
белый / бук  
biały / buk  
fehér / bükkfa  
bílý / buk  
bela / bukev  
valkoinen / pyökki  
vit / beech  
biely / buk  
alb / fag  
beyaz / kayın

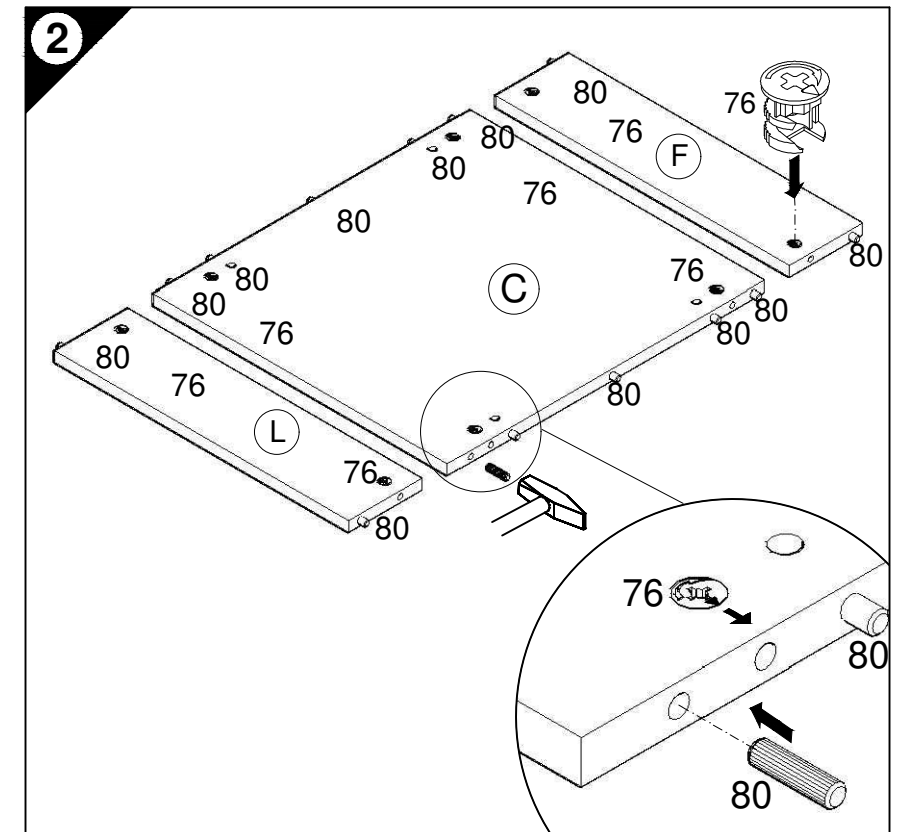
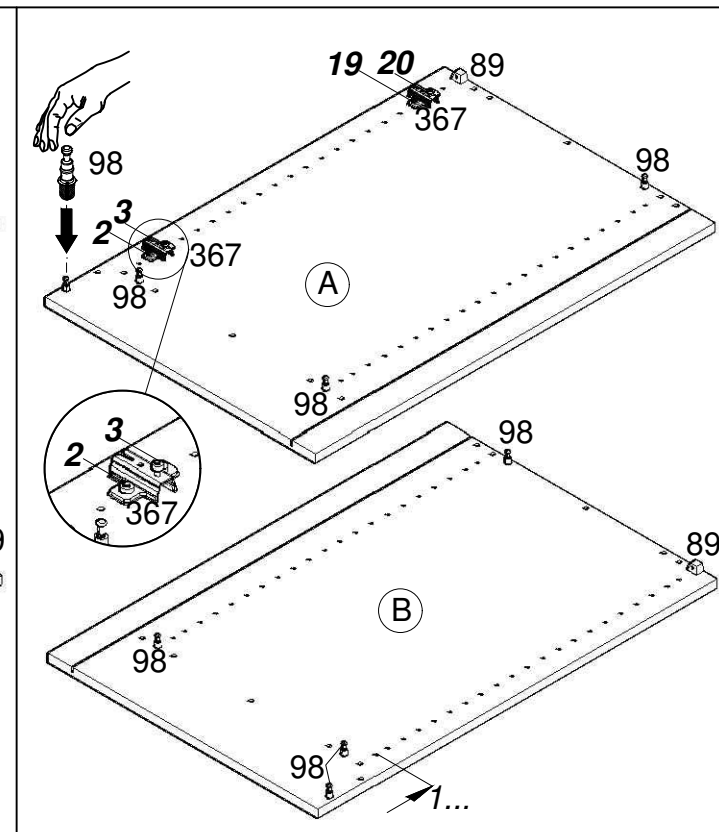

Ersatzteile/Spare parts/pièces de rechange/Reserveonderdelen/Piezas de recambio/Ricambi/Запасные части/Części zamienne/pótalkatrészek/Náhradní části/Nadomestni deli/varaosat/reservdelar/náhradné diely/Utilizați piese de schimb/Yedek parçalar

50cm SPLO506-9 / -6 | (A) E961021 (B) E961022 (C) E954224 (F) E970974 (G) E445043 (H) E940622 (L) E970974  
weiß/buche SPLO506-9 / -6 | (A) E981021 (B) E981022 (C) E954224 (F) E970974 (G) E445043 (H) E940622 (L) E970974

1 → 2 → 3 ...

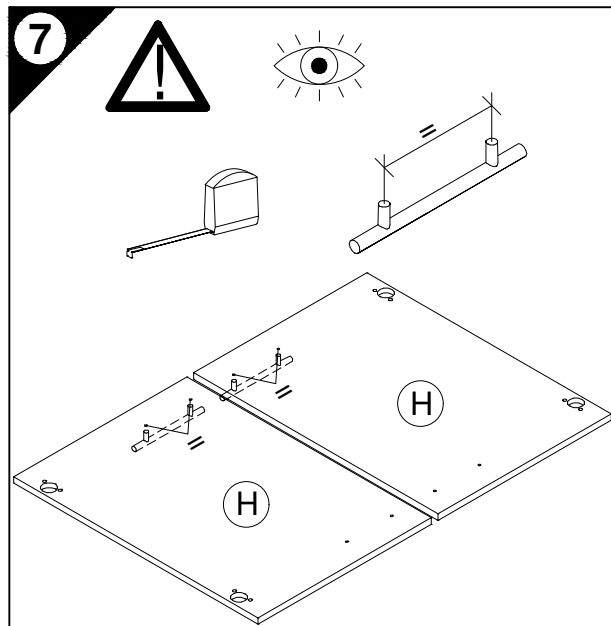
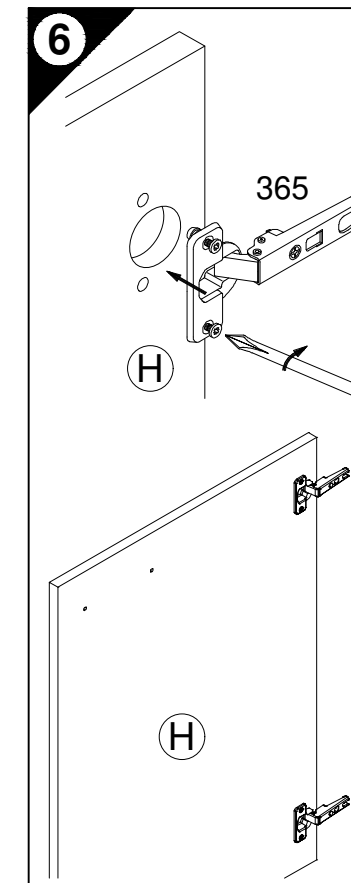
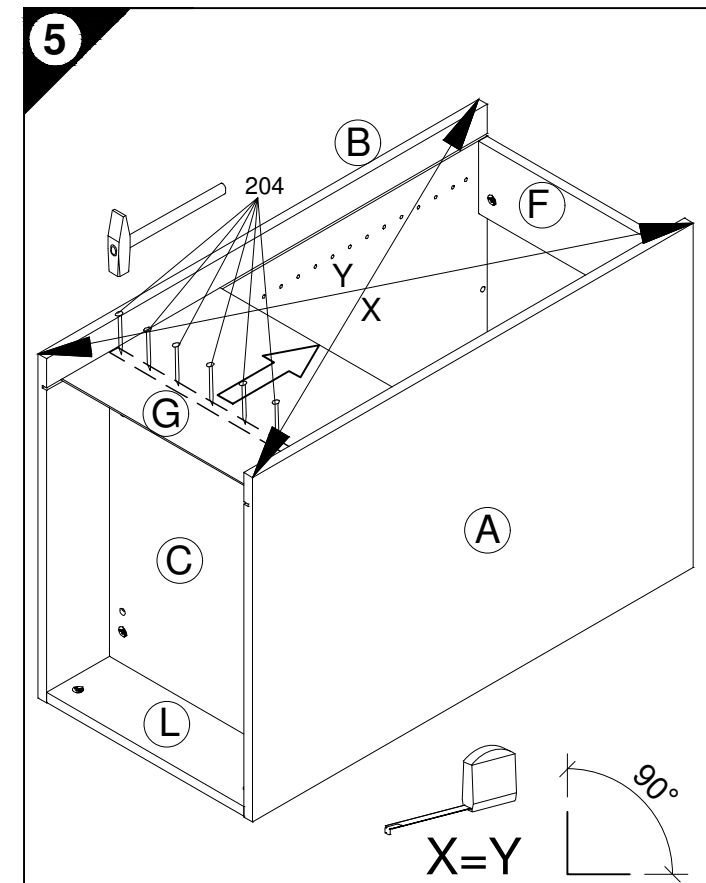
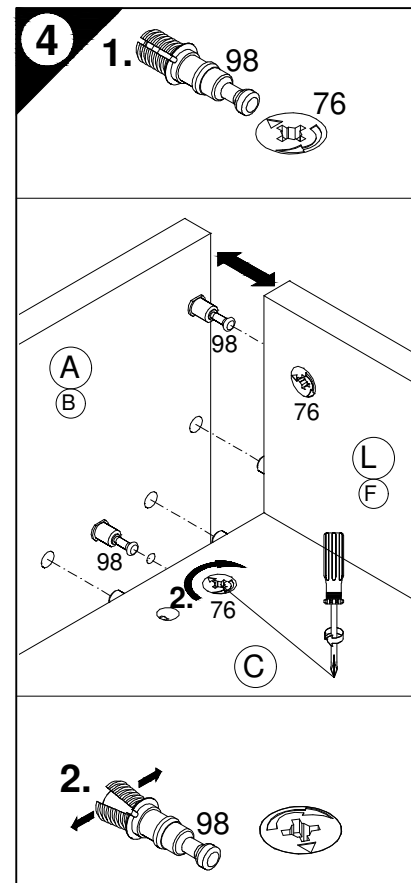
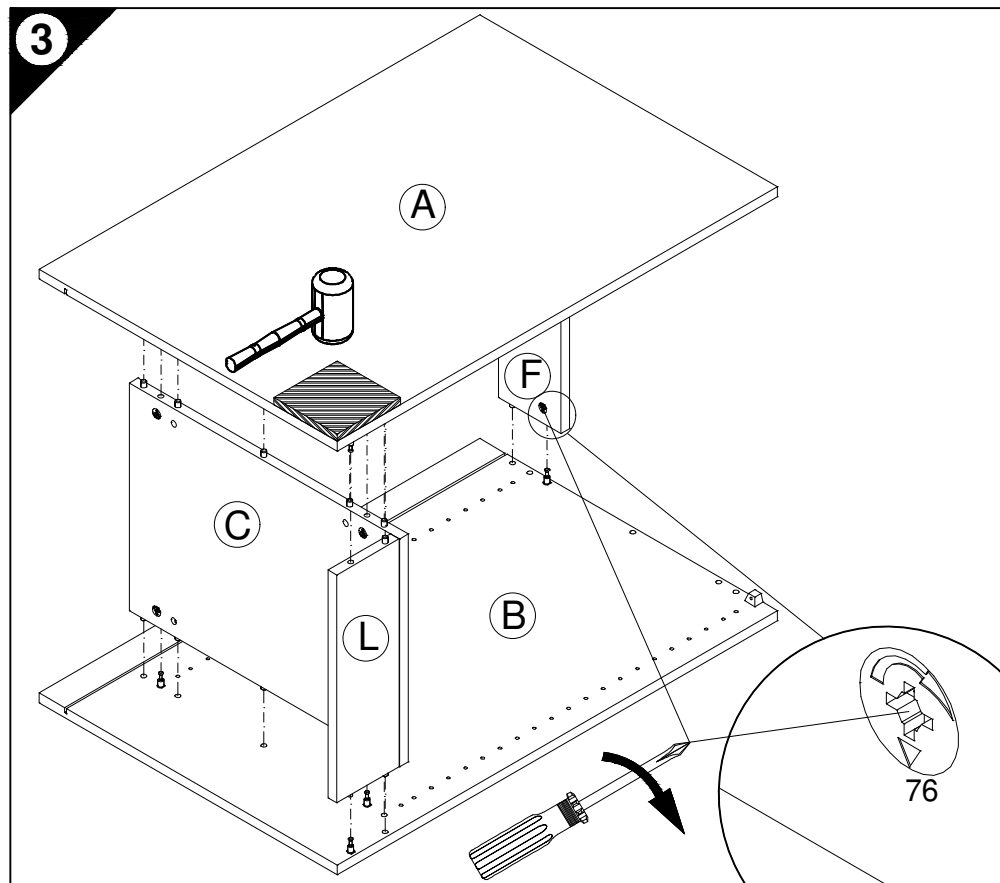
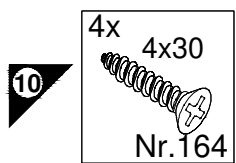
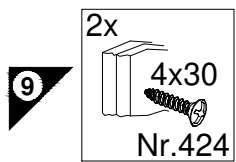
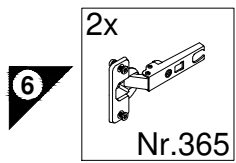
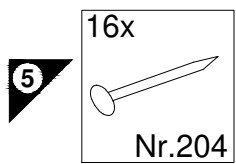

D Holzunterlage verwenden!  
Front andrücken, scharfen Bohrer verwenden  
und mit wenig Druck durchbohren!

GB Use a wooden base!  
Press front down, use sharp drill bit  
and, by applying slight pressure, drill a hole

F Utiliser un support en bois !  
Appuyer sur la façade, utiliser un foret bien affûté  
et percer en appliquant une faible pression !

NL Houten onderlegger gebruiken!  
Druk het front aan, gebruik een scherpe boor  
en oefen bij het boren weinig druk uit!

E ¡Utilizar una base de madera!  
¡Presionar el frente, utilizar una broca afilada  
y taladrar con poca presión!

I Appoggiare la facciata, utilizzare una punta di trapano affilata  
e trapanare esercitando solo una leggera pressione!

RUS Использовать деревянную подложку!  
Прижать фасад, использовать острое сверло  
и просверлить с незначительным давлением!

PL Używać podkładkę z drewna!  
Docisnąć front, użyć ostrego wiertła  
i przewiercić, używając małej siły nacisku!

H Alkalmazzon fa alátétet!  
Nyomja le az előlapot, használjon éles fúrót,  
és kis nyomással fúrja át!

CZ Použijte dřevěný podklad!  
Přitlačte čelo, použijte ostrý vrták  
a provrtějte pomocí malého tlaku!

SLO Uporabite leseno podlago!  
Pritisnite ličnico ter z ostrim svedrom  
in z majhnim pritiskom izvrtajte luknjo!

FIN Käytä puualustaa!  
Paina etulevy paikoilleen, käytä terävää poranterää  
ja poraa reikä vain kevyesti painamalla!

S Använd ett träunderlag!  
Tryck fronten mot underlaget, använd vass borr  
och borra igenom med ett lätt tryck!

SK Použite drevený podklad!  
Pritlačte front, použite ostrý vrták a prevrtajte miernym tlakom!

RO suport de lemn! Împingeți frontul, utilizați un burghiu ascuțit  
și perforați exercitând doar o presiune redusă!

TR Ahşap taban kullanın!  
Önden bastırın, keskin matkap ucu kullanın ve az basınç  
uygulayarak delin!

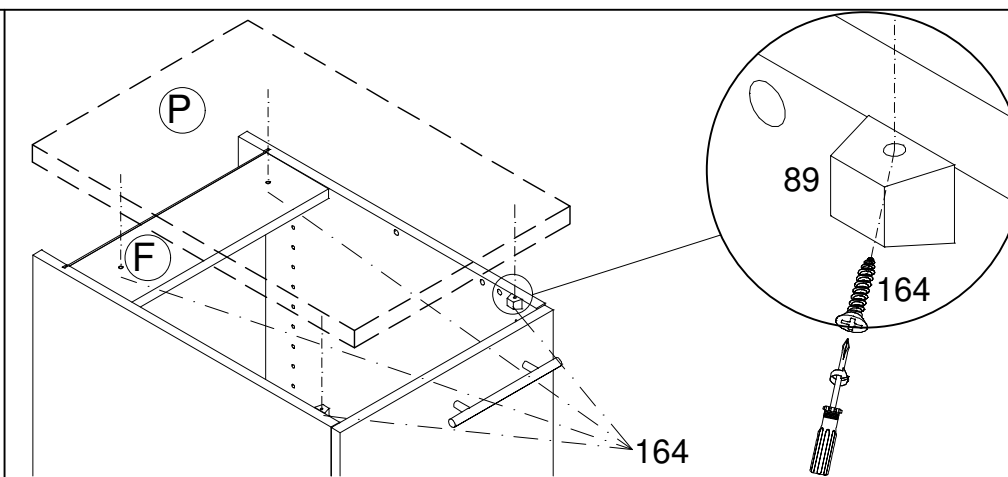
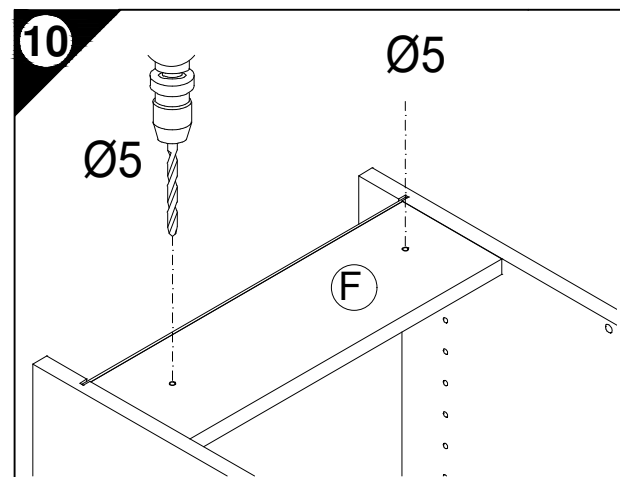
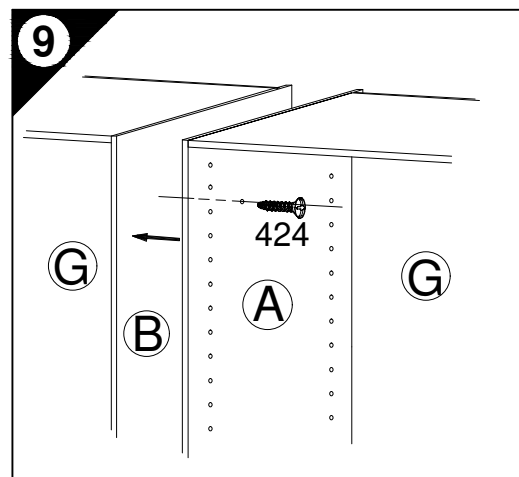
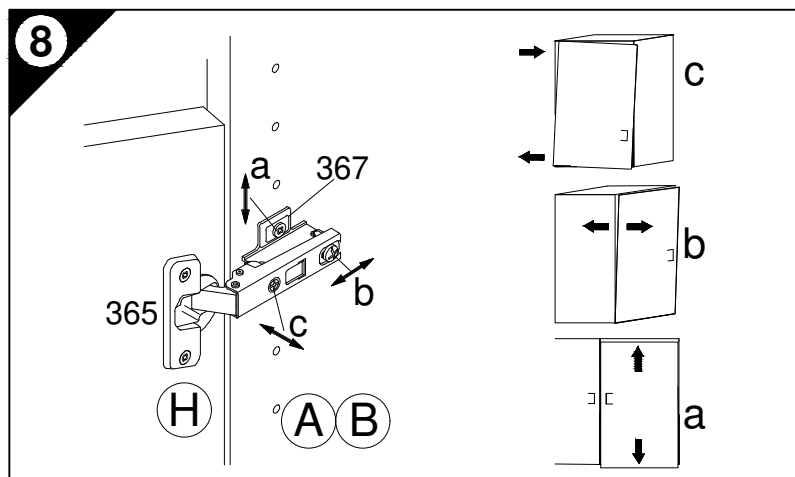
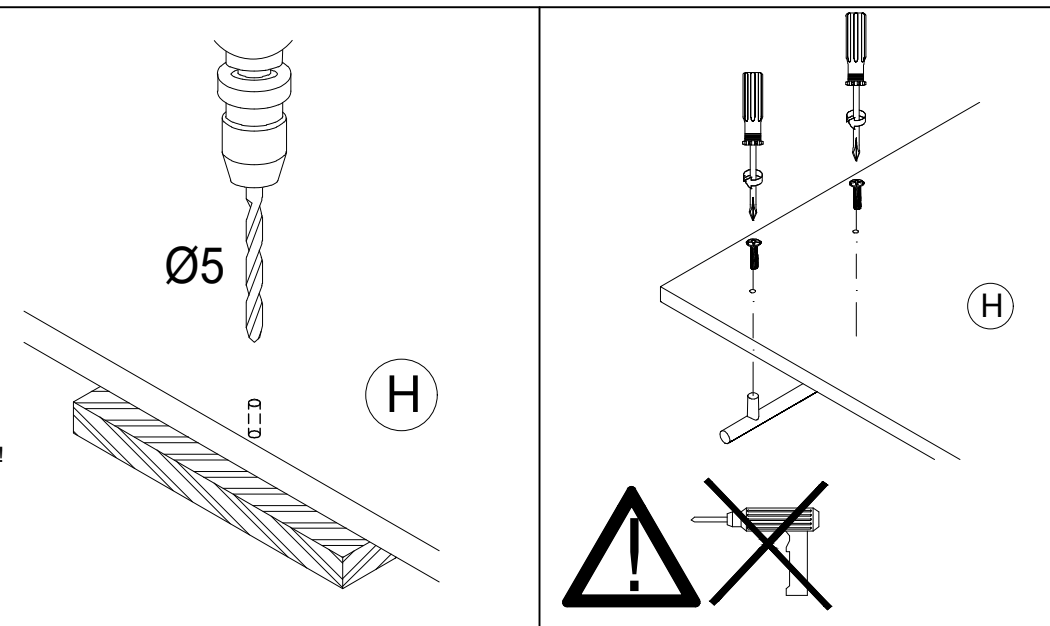



JAKA-BKL GmbH  
Jaka Straße 3  
D-32351 Sternwede-Wehden

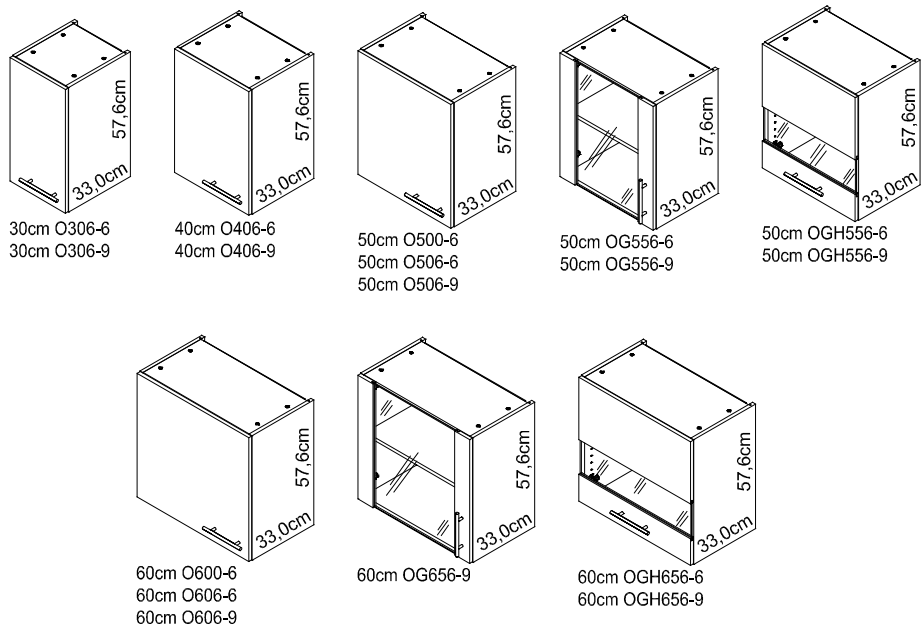
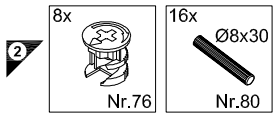
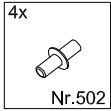
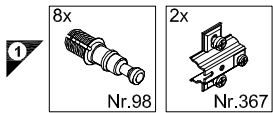
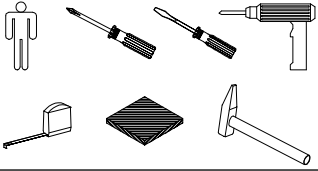

# Montageanleitung

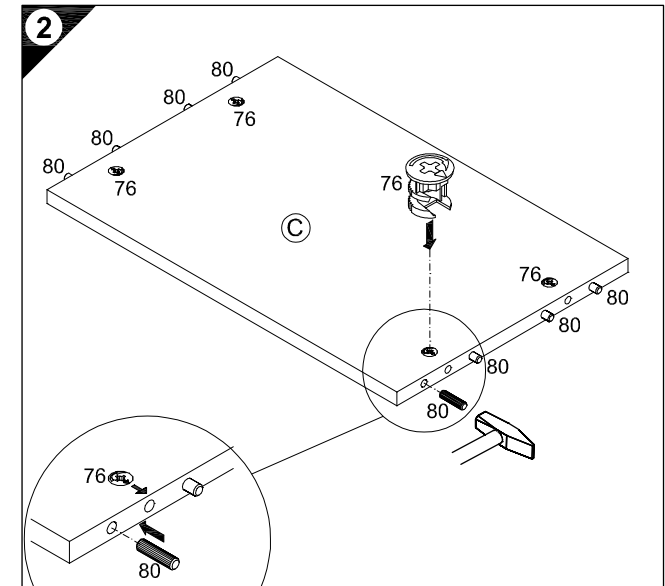
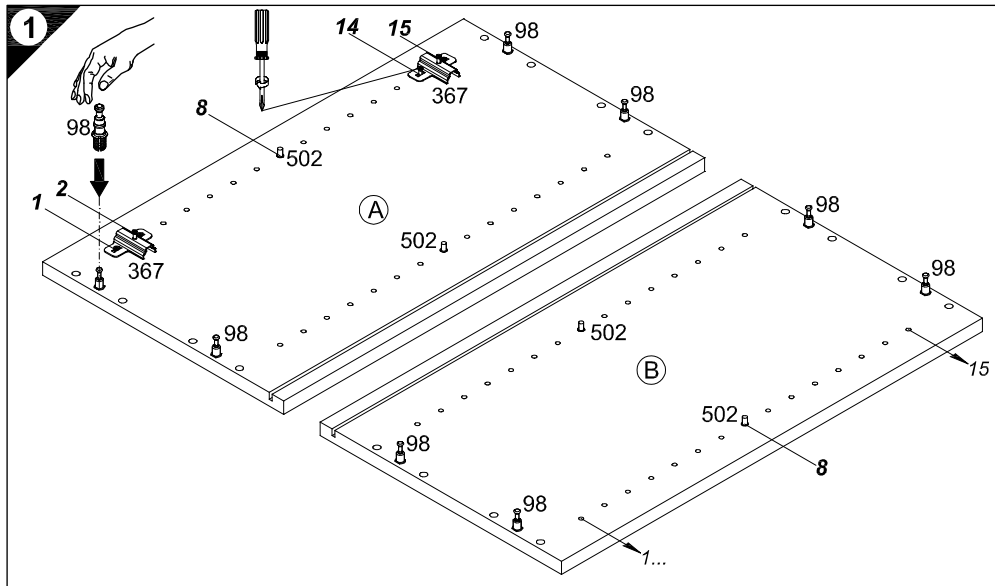
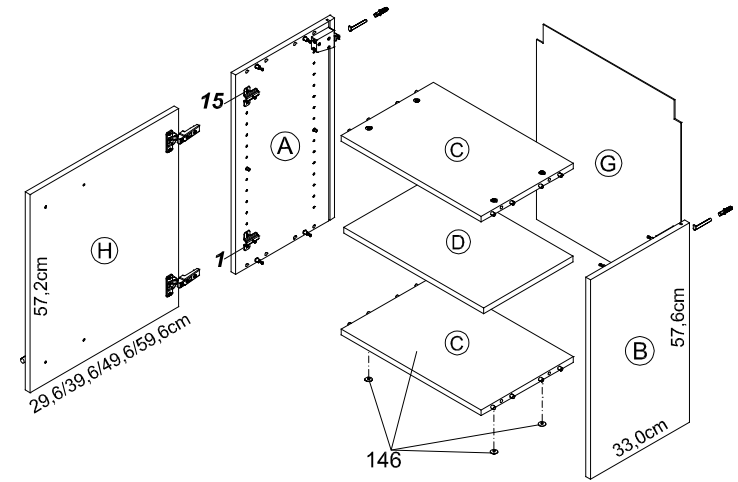

**Service-Hotline**  
**01805-678101**  
0,14€ pro Minute  
**++49 für Österreich**  
Auslandstarif pro Minute  
**service@jaka-bkl.de**  
voor Nederland en België  
**00800-40119350**  
**benelux@jaka-bkl.de**

Ersatzteile/Spare parts/pièces de rechange/Reserveonderdelen/Piezas de recambio/Ricambi/Запасные части/Części zamienne/pótkatrészek/Náhradní části/Nadomestni deli/varaosat/reservdelar/náhradné diely/Utilizați piese de schimb/Yedek parçalar

30cm O306-6/-9	(A) E940036	(B) E940036	(C) E941236	(D) E940336	(G) E971015	(H) E940614
40cm O406-6/-9	(A) E940036	(B) E940036	(C) E941235	(D) E940335	(G) E971014	(H) E940613
50cm O500	(A) E940036	(B) E940036	(C) E941234	(D) E940334	(G) E970032	(H) E980612
50cm O506-6/-9	(A) E940036	(B) E940036	(C) E941234	(D) E940334	(G) E970032	(H) E940612
60cm O600	(A) E940036	(B) E940036	(C) E941233	(D) E940333	(G) E971012	(H) E980611
60cm O606-6/-9	(A) E940036	(B) E940036	(C) E941233	(D) E940333	(G) E971012	(H) E940611

50cm OG556-6/-9	(A) E940036	(B) E940036	(C) E941234	(D) E940334	(G) E970032	(H) E940647
50cm OGH556-6/-9	(A) E940036	(B) E940036	(C) E941234	(D) E940334	(G) E970032	(H) E940655
60cm OGH656-6/-9	(A) E940036	(B) E940036	(C) E941233	(D) E940333	(G) E971012	(H) E980657
60cm OG656-9	(A) E940036	(B) E940036	(C) E941233	(D) E940333	(G) E971012	(H) E940657

1 → 2 → 3 ...

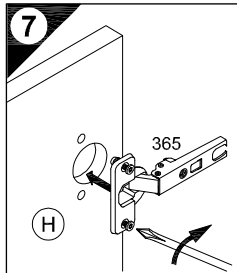
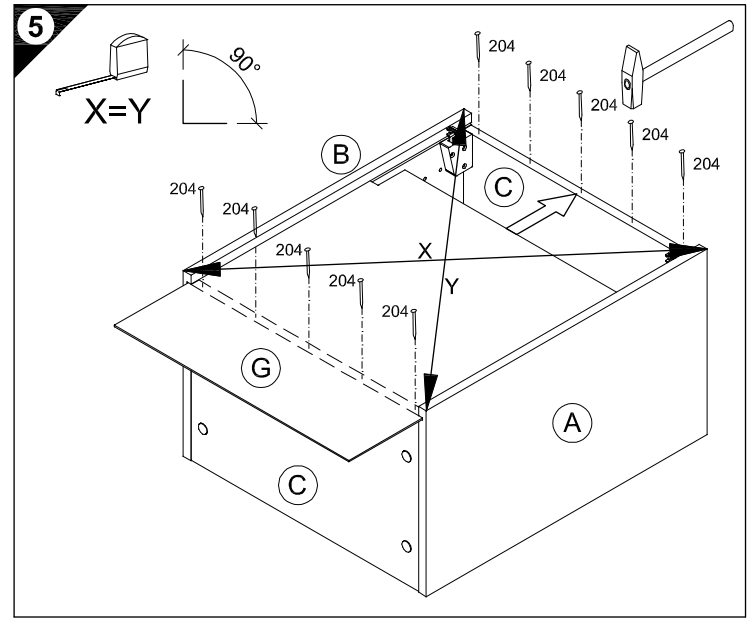
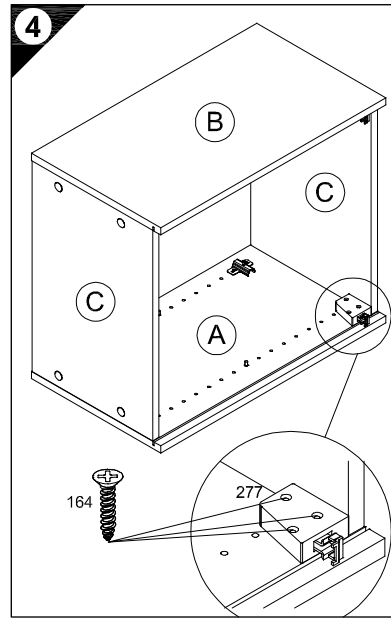
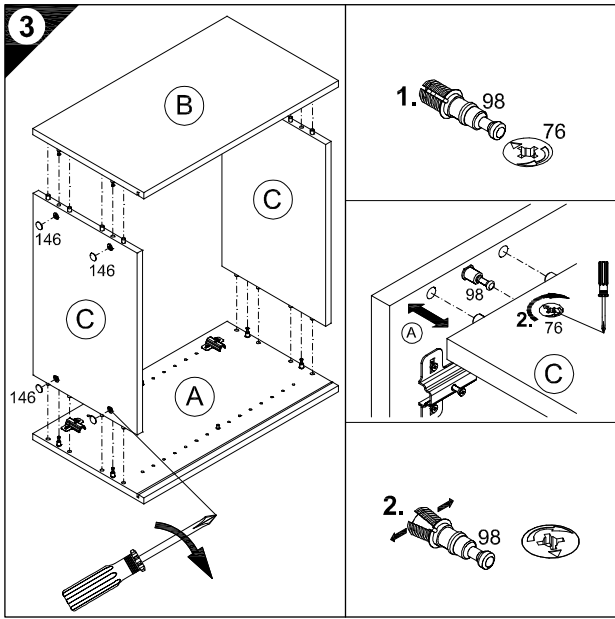
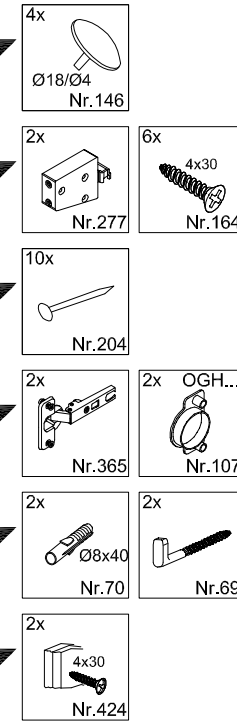

OGH556-6 / -9  
OGH656-6 / -9

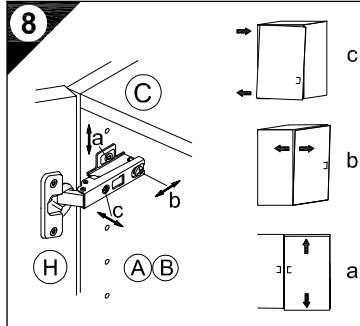
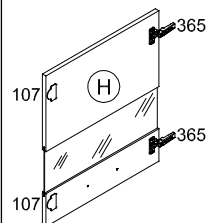

**8**

D Untergrund und Befestigungsmittel auf Eignung prüfen!  
GB Check substructure and fixings for suitability!  
F Contrôler si le support et les moyens de fixation sont bien adéquats !  
NL Ondergrond en bevestigingsmateriaal op functionaliteit controleren!  
E ¡Comprobar el suelo y los medios de fijación en cuanto a su aptitud!  
I Controllare l'idoneità del fondo e del materiale di fissaggio!  
RUS Основание и крепежный материал проверить на пригодность!  
PL Podłoże oraz materiały do zamocowania sprawdzić na ich przydatność!  
H Az alapfelületet és a rögzítő anyagokat megfelelőség szempontjából ellenőrizni kell!  
CZ Přezkoušejte podklad a vhodnost upevňovacích prostředků!  
SLO Preverite, če se ujemajo spodnja stran in pritrilna sredstva!  
FIN Tarkista alustan ja kiinnitysvälineiden sopivuus!  
S Kontrollera att underlaget och fästmedlen är lämpliga!  
SK Preverte vhodnosť podkladu a upevňovacích prostriedkov!  
RO Verificati caracterul adecvat al suprafeței suport și al mijloacelor de fixare!  
TR Zeminin ve bağlanlı elemanların uygunluğunu kontrol edin!

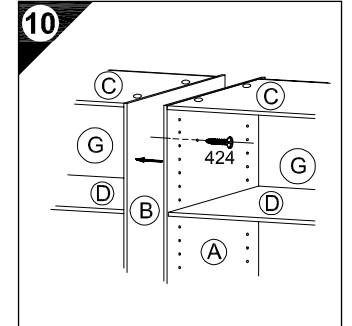
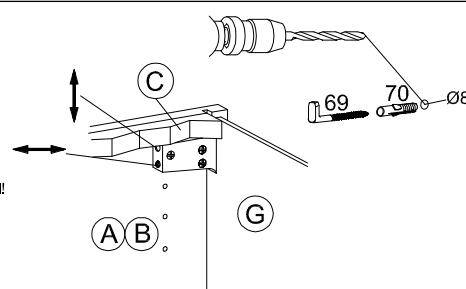

**6**

D Holzunterlage verwenden!  
Front andrücken, scharfen Bohrer verwenden und mit wenig Druck durchbohren!  
GB Use a wooden base!  
Press front down, use sharp drill bit and, by applying slight pressure, drill a hole  
F Utiliser un support en bois !  
Appuyer sur la façade, utiliser un foret bien affûté et percer en appliquant une faible pression !  
NL Houten onderlegger gebruiken!  
Druk het front aan, gebruik een scherpe boor en oefen bij het boren weinig druk uit!  
E ¡Utilizar una base de madera!  
¡Presionar el frente, utilizar una broca afilada y taladrar con poca presión!  
I Utilizzare una base di legno!  
Appoggiare la facciata, utilizzare una punta di trapano affilata e trapanare esercitando solo una leggera pressione!  
RUS Использовать деревянную подложку!  
Прижать фасад, использовать острое сверло и просверлить с незначительным давлением!  
PL Używać podkładkę z drewna!  
Docisnąć front, użyć oстрого wiertła i przewiercić, używając małej siły nacisku!

H Alkalmazzon fa alátétet!  
Nyomja le az előlapot, használjon éles fúrót, és kis nyomással fúrja át!  
CZ Použijte dřevěný podklad!  
Přitlačte čelo, použijte ostrý vrták a provrtajte pomocí malého tlaku!  
SLO Uporabite leseno podlago!  
Priltsnite lönico ter z ostrim svedrom in z majhnim pritiskom izvrtajte luknjo!  
FIN Käytä puualustaa!  
Paina etulevy paikoilleen, käytä terävää poranterää ja poraa reikä vain kevyesti painamalla!  
S Använd ett träunderlag!  
Tryck fronten mot underlaget, använd vass borr och borra igenom med ett lätt tryck!  
SK Použite drevený podklad!  
Prítlačte front, použite ostrý vrták a prevrtajte miernym tlakom!  
RO suport de lemn!  
Împingeți frontul, utilizați un burghiu ascuțit și perforați exercitând doar o presiune redusă!  
TR Ahşap taban kullanın!  
Önden bastırın, keskin matkap ucu kullanın ve az basınç uygulayarak delin!

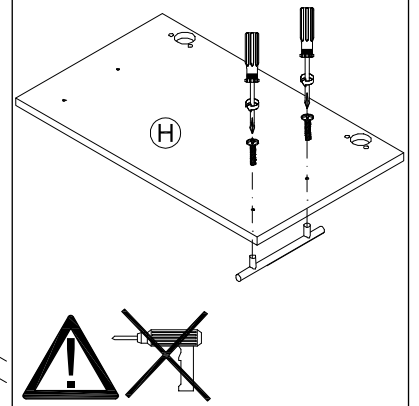
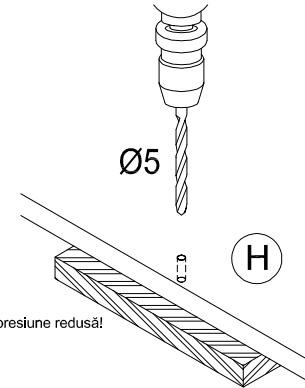

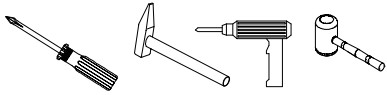
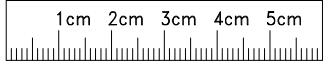

# Montageanleitung

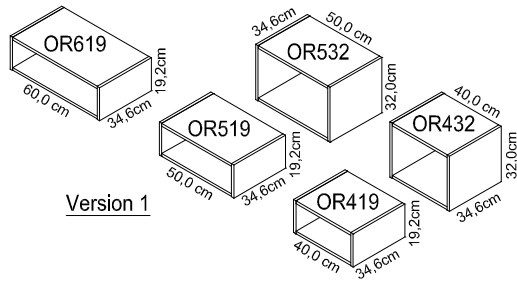

Version 1

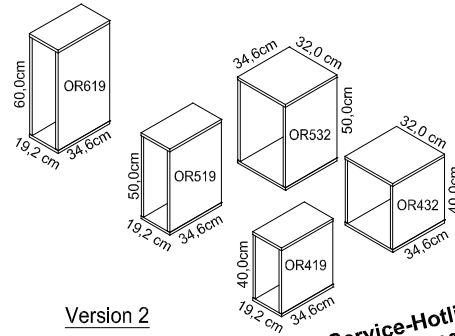

Version 2

**Service-Hotline**  
**01805-678101**  
0,14€ pro Minute  
**++49 für Österreich**  
Auslandstarif pro Minute  
**service@jaka-bkl.de**  
voor Nederland en België  
**00800-40119350**  
benelux@jaka-bkl.de

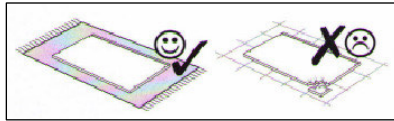
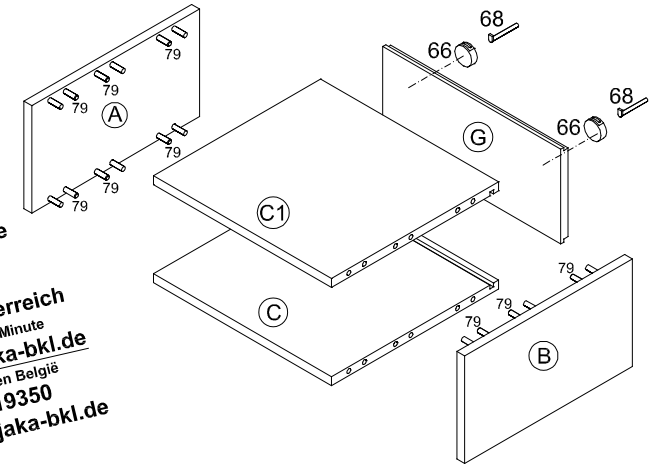

- 1 → 2 → 3 → ...
- 1 12x Ø8x35 Nr.217, 1x Nr.128, 12x Ø8x35 Nr.79
- 2 2x Ø35 Nr.66, 4x 3x15 Nr.67
- 3 1x Nr.128
- 6 2x Ø8x40 Nr.70, 2x Nr.68

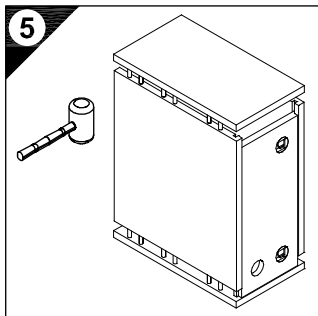
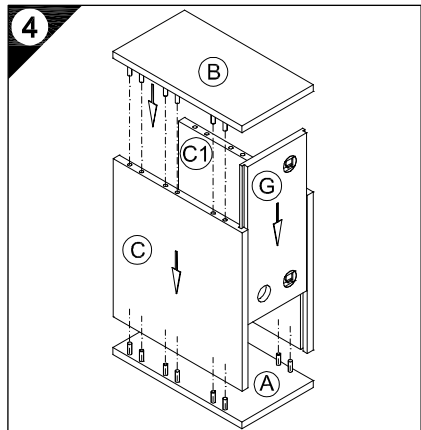
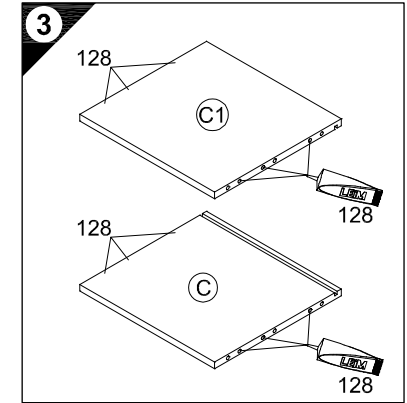
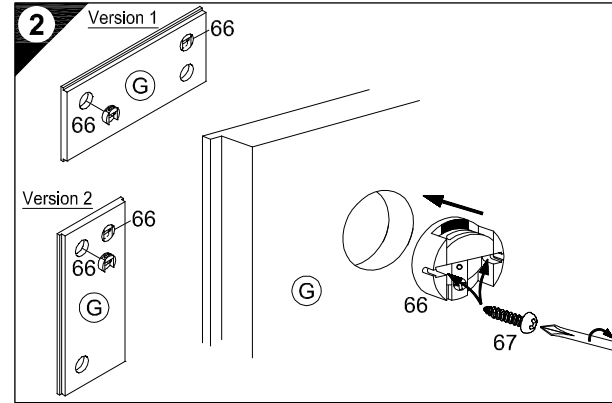
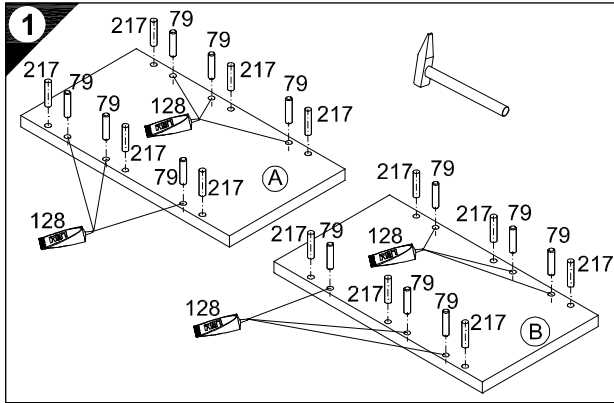

**6** Untergrund und Befestigungsmittel auf Eignung prüfen!  
Check substructure and fixings for suitability!  
Contrôler si le support et les moyens de fixation sont bien adéquats !  
Ondergrond en bevestigingsmateriaal op functionaliteit controleren!  
¡Comprobar el suelo y los medios de fijación en cuanto a su aptitud!  
Controllare l'idoneità del fondo e del materiale di fissaggio!  
Основа и крепежный материал проверить на пригодность!  
Podłoże oraz materiały do zamocowania sprawdzić na ich przydatność!  
Az alapfelületet és a rögzítő anyagokat megfeleléség szempontjából ellenőrizni kell!  
Přezkoušejte podklad a vhodnost upevňovacích prostředků!  
Preverite, če se ujemajo spodnja stran in pritrilna sredstva!  
Tarkista alustan ja kiinnittinten sopivuus.  
Kontrollera att underlaget och fästmedlen är lämpliga!

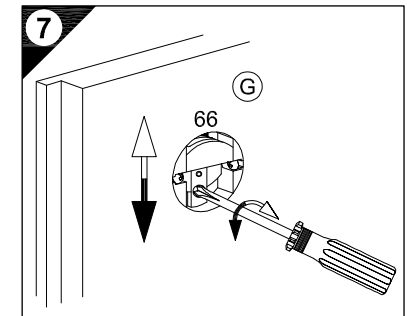

Ersatzteile/Spare parts/pièces de rechange/Reserveonderdelen/Piezas de recambio/Ricambi/Запасные части/Części zamiennel/pótalkatrészek/Náhradní části/Nadomestni deli/varaosat/reservdelar

40cm OR419	(A) E940050	(B) E940050	(C) E941250	(C1) E941250	(G) E940090
40cm OR432	(A) E940051	(B) E940051	(C) E941250	(C1) E941250	(G) E940091
50cm OR519	(A) E940050	(B) E940050	(C) E941251	(C1) E941251	(G) E940093
50cm OR532	(A) E940051	(B) E940051	(C) E941251	(C1) E941251	(G) E940095

60cm OR619	(A) E940050	(B) E940050	(C) E941252	(C1) E941252	(G) E940095
------------	-------------	-------------	-------------	--------------	-------------

# SERVICEKARTE

VH

Liebe Kundin, lieber Kunde,

obwohl wir unsere Möbel vor der Auslieferung einer eingehenden Endkontrolle unterziehen, kann es vorkommen, dass einmal ein Zubehörteil fehlt oder während des Transports beschädigt wird. Senden sie den Artikel bitte nicht zurück, sondern fordern sie einfach Ersatz für das Einzelteil bei unserer Kundenhotline an. Die Telefonnummern finden sie auf den Serviceseiten im Katalog.

Bitte benennen sie die Teile wie sie auf ihrer Aufbauanleitung angegeben sind. Fügen sie auch **Artikelnummer, Modellnamen und Farbnummer** bei. **Siehe Beispiel.**

Wir werden ihre Anforderung sofort bearbeiten und ihnen das Ersatzteil umgehend zusenden.

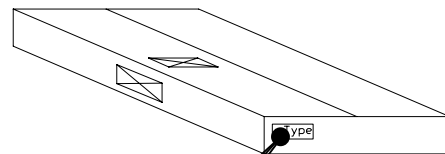
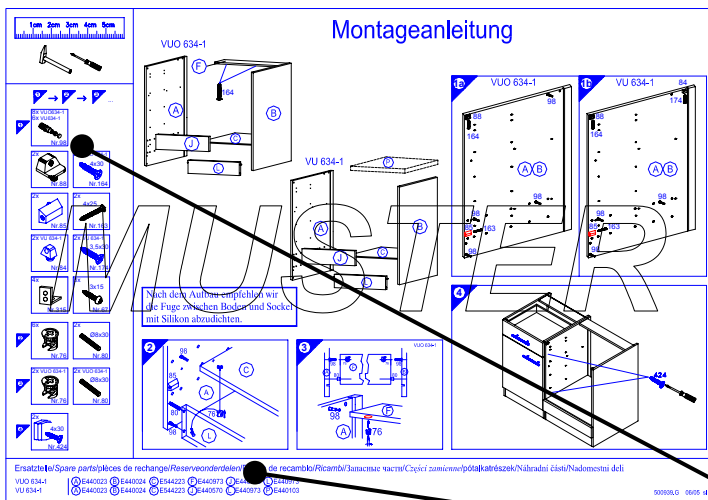

Muster - Bestellung		
Artikelnummer	123 456	
Modellname	Unterschrank VU634	
Farbe	TA 01	
Benötigte Ersatzteile:		
Bezeichnung	Nr.	Anzahl
Beschlagteil	98	2
Teil B	E 440 023	1

Bitte entnehmen sie die notwendige Ersatzteilnummer der Aufbauanleitung die zum Möbel gehört!

Kundendaten	
Kundennummer	
Name	
Vorname	
Strasse	
Haus-Nr.	
PLZ	
Ort	
Rechnungsdatum	
Tel. für Rückfragen	
Notizen:	

Ersatzteilbestellung		
Artikelnummer		
Modellname		
Farbe		
Benötigte Ersatzteile:		
Bezeichnung	Nr.	Anzahl
Grund der Ersatzteilanforderung:		

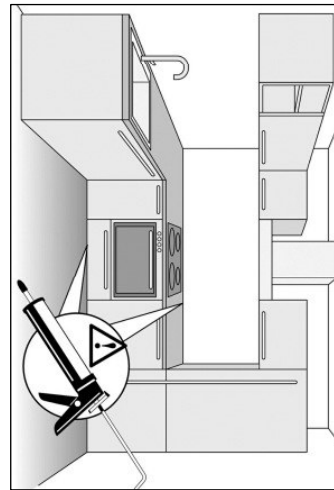
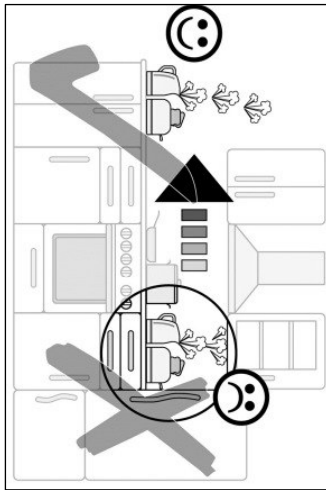
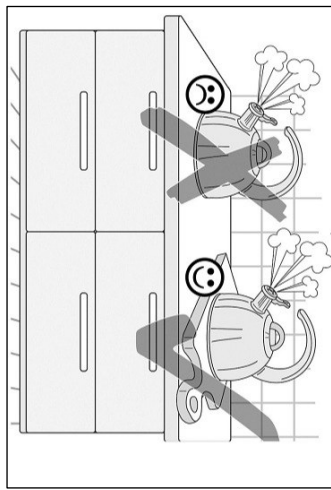
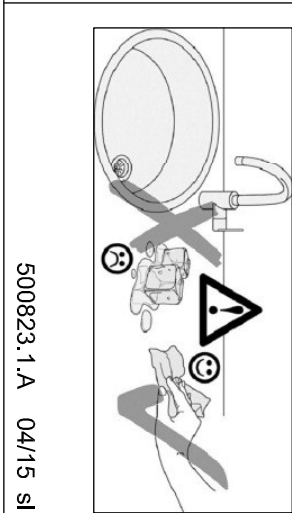
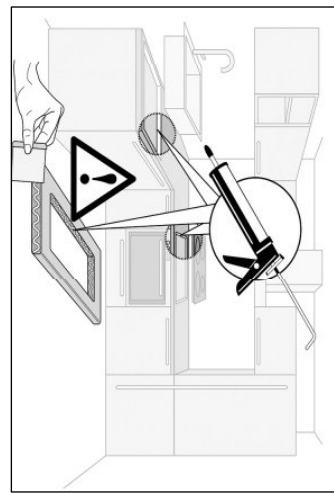
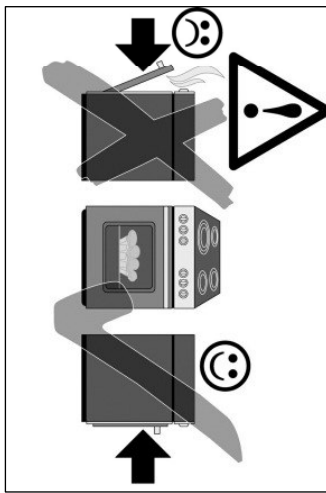
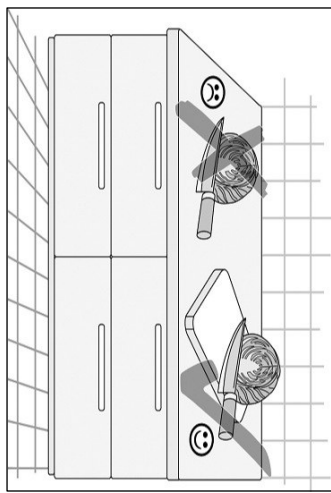
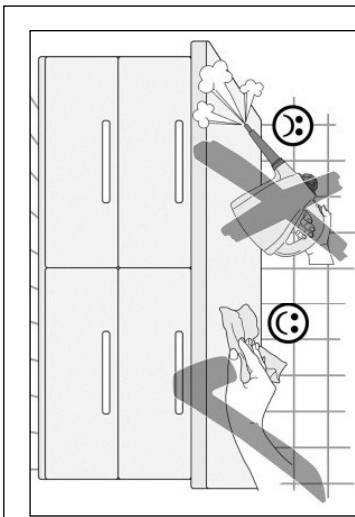

500823.1.A 04/15 SI

## D Pflegehinweise

### Kunststoff-Oberflächen:

Kunststoffbeschichtete Oberflächen/Fronten lassen sich mit haushaltsüblichen Reinigungsmitteln pflegen. Am besten geht das mit einem weichen Tuch, handwarmen Wasser und etwas Spülmittel. Verwenden Sie keine polierenden Reinigungsmittel oder harte Schwämme! Hartnäckige Flecken, wie Fettspritzer, Lack- oder Klebstoffreste, sind mit einem handelsüblichen Kunststoffreiniger zu beseitigen. Vor dem ersten Gebrauch dieser Mittel empfiehlt es sich, diese an einer nicht sichtbaren Stelle zu prüfen!

**Glänzende Fronten:** Diese Fronten nie trocken reinigen!  
Die Verwendung von schleifenden Reinigungsmitteln (Mikrofaserlappen, Scheuerschwämme etc.) können zu erhöhter Bildung von Kratzern führen und sind kein Reklamationsgrund. Verwenden Sie daher am besten ein staubfreies Tuch oder ein feuchtes Fensterleder.

### Einbauspülen und Herdmulden:

Einbauspülen, Herdmulden sowie alle nicht genannten Artikel aus rostfreiem Stahl pflegen Sie am besten mit einem Schwamm oder einem Vlies Tuch unter Verwendung von Spülmittel oder mit den bekannten Spezialpflegemitteln (Edelstahlreiniger, Metall-Polish). Bei Einbauspülen aus anderen Materialien wie Porzellan, Kunststoff, Acryl-Keramik sowie bei Edelstahlpülen milde Spül- oder Reinigungsmittel verwenden.

Bitte beachten Sie außerdem die speziellen Pflegehinweise der Hersteller!

### Glaskeramik-Kochfelder:

Hartnäckige Verschmutzungen, Kalk- und Wasserflecken sowie glänzende Topfabrieb beseitigen Sie mit dem vom Hersteller empfohlenen Spezialreiniger (z.B. Cerafix, Stahlfix). Festgebrannte Verkrustungen (Zucker, Salz oder zuckerhaltige Speisereste) entfernen Sie, in noch heißem Zustand, mit einem Glasschaber.

Beachten Sie hierzu auch die Bedienungsanleitung des Geräteherstellers!

### Griffe:

Verzichten Sie auf lösungsmittelhaltige und aluminiumschädigende Substanzen sowie auf Essigreiniger, da diese zu einer nicht mehr entfernbaren Fleckenbildung führen können.

## GB Care instructions

### Synthetic Surfaces:

Synthetic finishes on surfaces/fronts can be cared for with common household cleaners. It's best to use a soft cloth, hand warm water and a little washing-up liquid. Do not use any polishing cleaners or hard sponges! Stubborn marks, such as grease splashes, paint or adhesive residues can be removed with common, commercially available synthetic materials cleaners. However, it is recommended that these be tested on an inconspicuous area before using them for the first time!

**Gloss Fronts:** Never clean these fronts in the dry state!

Fitted sink units and all other articles made of stainless steel are best cleaned using a sponge or a fleece cloth with a washing-up liquid or known specialty cleaner (stainless steel cleaner, metal polish). Use mild washing-up or cleaning liquids on fitted sinks made of other materials, such as porcelain, synthetic material, acrylic ceramic as well as stainless steel. In addition, make sure to always follow the specific care instructions provided by the respective manufacturer!

### Ceramic Glass Hobs:

Stubborn marks, limescale and water spots and shiny marks left by pots are best removed with special cleaners as recommended by the manufacturer. Use a glass scraper to remove burnt-on marks (sugar, salt or food spillages containing sugar) while still hot. Please also refer to the operating instructions provided by the appliance manufacturer!

### Handles:

Avoid using substances containing solvents or which are harmful to aluminum, as well as cleaners containing vinegar, as these can cause permanent discolouration.

## NL Onderhoudsinstructies

### Kunststof-opervlakken:

Oppervlakken/fronten met een kunststof coating kunnen met een gangbaar huishoudelijk reinigingsmiddel worden verzorgd. Dat gaat het beste met een zacht doekje, handwarm water en een beetje afwasmiddel. Gebruik geen polijstende reinigingsmiddelen of harde sponjes! Hardnekkige vlekken, resten van lak of lijm, moeten met een gangbaar reinigingsmiddel voor kunststof worden verwijderd. Voor het eerste gebruik van dit middel is het aan te bevelen om dit op een niet zichtbare plek uit te proberen!

**Glänzende fronten:** Deze fronten nooit droog reinigen!

Het gebruik van schurende reinigingsmiddelen (microvezeldoekjes, schuursponsjes etc.) kunnen tot snellere vorming van krasjes leiden en zijn geen reden voor een reclamatie. Gebruik daarom het beste een stofvrij doekje of een vochtige zeem.

### Inbouwgootstenen en kookplaten:

Inbouwgootstenen, kookplaten en alle niet genoemde artikelen van roestvast staal reinigt u het beste met een sponsje of een vlieddoek met afwasmiddel of met de bekende speciale reinigers (vrs-reiniger, metaal-polish). Bij gootstenen van andere materialen zoals porselein, kunststof, acryl-keramiek en bij gootstenen van edelstaal milde afwas- of reinigingsmiddelen gebruiken. Neem bovendien de speciale reinigingsinstructies van de fabrikanten in acht!

### Glaskeramische kookplaten:

Hardnekkig vuil, kalk- en watervlekken en glanzende slijtplekken van pannen verwijdert u met het door de fabrikant aanbevolen speciale reinigingsmiddel (bijv. Cerafix, Stahlfix). Aangekoekte en vastgebrande resten (suiker, zout of suikerhoudende voedselresten) verwijdert u, in nog hete toestand, met een glasschraper. Raadpleeg hiervoor ook de handleiding van de fabrikant van het apparaat!

### Grepen:

Gebruik geen oplosmiddelhoudende en aluminium beschadigende substanties en geen schoonmaakazijn omdat deze tot vlekken kunnen leiden die niet meer te verwijderen zijn.

## F Conseils d'entretien

### Revêtements en plastique :

Les revêtements / fronts en plastique peuvent être entretenus au moyen d'un produit de nettoyage ménager courant. L'idéal est d'utiliser un chiffon doux, de l'eau tiède et un peu de produit pour la vaisselle. N'utilisez pas de produit de polissage ou d'éponges dures ! Éliminez les taches tenaces, telles que les projections de graisse et résidus de vernis ou de colle, au moyen d'un produit de nettoyage pour le plastique courant. Avant la première utilisation de ce produit, il est recommandé de tester celui-ci à un endroit dissimulé !

**Fronts brillants :** Ne nettoyez jamais ces fronts à sec !

L'utilisation de produits de nettoyage abrasifs (chiffons en microfibras, éponges abrasives, etc.) peut entraîner la formation accrue de rayures et ne peuvent justifier aucune réclamation. L'idéal est donc d'utiliser un chiffon non-pelucheux ou une peau de chamois humide.

### Eviens encastrés et tables de cuisson :

Les éviens encastrés et tables de cuisson, ainsi que tous les éléments en acier inoxydable n'étant pas cités ici doivent être entretenus avec une éponge ou une peau de chamois, imprégnées de produit vaisselle ou d'un produit spécifique (détergent inox, polish métal). Les éviens encastrés fabriqués dans d'autres matériaux, tels que de la porcelaine, du plastique, de la céramique acrylique, ainsi que les éviens en acier inoxydable doivent être nettoyés au moyen de produit vaisselle ou détergent doux. Respectez également les consignes d'entretien spécifiques du fabricant !

### Plaques vitrocéramiques :

Éliminez les taches tenaces, les taches de calcaire et d'eau, ainsi que les traces brillantes laissées par les casseroles au moyen du détergent spécial recommandé par le fabricant (par ex. Cerafix, Stahlfix). Éliminez les restes carbonisés (sucre, sel ou aliments sucrés) encore chauds au moyen d'un racloir. Respectez ici les instructions du fabricant de l'appareil !

### Polignées :

N'utilisez pas de substances à base de solvant et détergent l'aluminium ou produits à base de vinaigre ; ceux-ci peuvent causer des taches indélébiles.

<p><b>IT Consigli di manutenzione</b></p> <p><b>Superfici In materiale sintetico:</b> Le Superfici frontali rivestite in plastica possono essere trattate con un comune detergente per la casa. È da preferire l'utilizzo di un panno morbido, acqua tiepida e detersivo per piatti.</p> <p>Non utilizzare detersivi o spugne di tipo abrasivo! Le macchie più ostinate, come schizzi d'untio, residui di vernici o collanti possono essere rimosse con un comune detergente per superfici sintetiche, reperibile In commercio.</p> <p>Al primo utilizzo, si consiglia di provare Il detergente su un punto non visibile della superficie!</p> <p><b>Frontali lucidi:</b> questo tipo di frontali non deve mai essere pulito da asciutto!</p> <p>L'utilizzo di materiali abrasivi (panni in microfibra, pagliette ecc.) può aumentare il rischio di graffio delle superfici: la presenza di graffi non è da considerarsi motivo valido per alcun reclamo.</p> <p>Si consiglia l'utilizzo di un panno che non lasci pelucchi o di una pelle di daino umida.</p> <p><b>Lavelli o piani cottura da incasso:</b> Per la manutenzione di lavelli, piani cottura o qualsivoglia altra unità In acciaio Inox è consigliabile l'uso di una spugna o di un panno felpato, sapone per piatti o detergente specifico (detergente per acciaio, metallo).</p> <p>Per la pulizia di lavelli In ceramica, In plastica o In acciaio, così come per quelli In acciaio è consigliabile l'uso di sapone per piatti o di un detergente delicato. Seguire inoltre i consigli per la manutenzione specifici, forniti dal produttore!</p> <p><b>Piani cottura In vetro ceramica:</b> Le macchie più ostinate, il calcare, gli aloni creati dall'acqua, così come i segni lucidi lasciati dai tegami, possono essere rimossi con l'utilizzo di prodotti specifici, consigliati dallo stesso produttore (ad esempio Cerafix, Stahlfix). Qualsivoglia incrostazione (di zucchero, sale o di altri alimenti contenenti zucchero) potrà essere rimossa, a piano ancora caldo, con un raschietto per vetro.</p> <p>Seguire sempre le indicazioni del produttore!</p> <p><b>Mantiglie:</b> Evitare l'uso di prodotti contenenti solventi, che possano rovinare le superfici in alluminio o a base d'acetato, tali prodotti potrebbero infatti dar luogo a macchie permanenti.</p>	
---	--

## CZ Pokyny pro ošetřování

<p><b>Plastové povrchy:</b> Pláštěm potažené povrchy/čela lze ošetřovat běžnými čisticími prostředky pro domácnost. Nejlépe provedete ošetření měkkou utěrkou a vlažnou vodou s malým množstvím mycího prostředku. Nepoužívejte leštidla čisticí prostředky nebo tvrdé mycí houby! Ulpělé fluky, jako skvrny od vystříknutého tuky, zbytky laku nebo lepidla je nutné odstranit běžným čisticím prostředkem na plasty. Před prvním použitím těchto prostředků se doporučuje je vyzkoušet na místě, které není viditelné!</p> <p><b>Lesklé čelní plochy:</b> Tato čela nikdy nečistěte nasucho!</p> <p>Používání abrazivních čisticích prostředků (úterky z mikrovlákna, drhnutích mycích houbiček atd.) mohou vést ke zvýšené tvorbě škrábanců a nejsou důvodem k reklamaci. Používejte proto nejlépe bezprašnou utěrku nebo vlhkou kůži na okna.</p> <p><b>Vestavné dřezy a varné desky:</b> Vestavné dřezy, zasklé skvrny usazenin a vody, jakož i všechny neuvedené artikly z nerezové oceli ošetřujte nejlépe houbičkou nebo utěrkou z netkané textilie s použitím mycího prostředku nebo se známými speciálními ošetřujícími prostředky (čisticí prostředek na ušlechtilou ocel, leštidla prostředky na kov). U vestavných dřezů z jiných materiálů jako porcelánu, plastu, akrylátové keramiky, jakož i u dřezů z nerezové oceli používejte jemné mycí nebo čisticí prostředky.</p> <p>Dbejte kromě toho na speciální pokyny pro ošetřování od výrobce!</p> <p><b>Sklokeramické varné desky:</b> Ulpělé nečistoty, zasklé skvrny usazenin a vody, jakož i lesklé stopy po otěru hrdí odstraňujte výrobcem doporučenými speciálními čisticími (např. Cerafix, Stahlfix). Pevně zapečené nánosy (cukr, sůl nebo zbytky jídla, obsahující cukr) odstraňujte ještě horké přiloženou skleněnou škrabkou. Dbejte přitom také na návod k obsluze výrobce přístroje!</p> <p><b>Madla:</b> Nepoužívejte látky obsahující rozpouštědla a poškozující hliník, jakož i čisticla obsahující ocet, protože to může vést ke vzniku neodstranitelných fleků.</p>	
--	--

<p><b>Műanyagfelületek:</b> A műanyag bevonatú felületek/frontok ápolása szokványos háztartási tisztítószerrel lehetséges. A legjobb a puha törökendő, langyos víz és némi mosogatószer használata. Ne használjon polírozó hatású tisztítószer vagy kemény szivacsot!</p> <p>A makacs foltok – pl. ráfőrcsönt zsír, lakk- vagy ragasztómaradványok – kereskedelemben kapható műanyagtisztítóval távolíthatók el. Az ilyen tisztítószerrek első használata előtt ajánlott próbát végezni egy nem látható helyen!</p> <p><b>Fényes frontok:</b> Az ilyen frontokat soha ne tisztítsa szárazon!</p> <p>A súroló hatású tisztítószerrek és -szkőzők (mikroszálás törökendők, súrolószivacsok stb.) használata fokozott karcosodást okoz, amit nem áll módunkban reklamáció alapjául elfogadni.</p> <p>Ezért a legjobb, ha pormentes törökendőt vagy ablaktisztító bőkendőt használ.</p> <p><b>Beépített mosogatók és főzőlapok:</b> A rozsdamentes acélből készült beépített mosogatók, főzőlapok és egyéb meg nem nevezett termékek ápolásának legkíméletesebb módja a szivacs vagy gyapjúkendő és némi mosogatószer vagy valamelyik ismert speciális ápolószer (nemesacél tisztító, Metall Polish) használata. Más anyagokból – pl. porcelán, műanyag, akril-kerámia – vagy nemesacélből készült beépített mosogatókhoz kímélő mosogató- vagy tisztítószer használjon.</p> <p>Kérjük, hogy ezenkívül a speciális gyártói ápolási tudnivalót is vegye figyelembe!</p> <p><b>Üvegkerámia főzőlapok:</b> A rozsdamentes acélből készült beépített mosogatók, főzőlapok és egyéb meg nem nevezett termékek ápolásának legkíméletesebb módja a szivacs vagy gyapjúkendő és némi mosogatószer vagy valamelyik ismert speciális ápolószer (nemesacél tisztító, Metall Polish) használata. Más anyagokból – pl. porcelán, műanyag, akril-kerámia – vagy nemesacélből készült beépített mosogatókhoz kímélő mosogató- vagy tisztítószer használjon.</p> <p>Kérjük, hogy ezenkívül a speciális gyártói ápolási tudnivalót is vegye figyelembe!</p> <p><b>Üvegkerámia főzőlapok:</b> A rozsdamentes acélből készült beépített mosogatók, főzőlapok és egyéb meg nem nevezett termékek ápolásának legkíméletesebb módja a szivacs vagy gyapjúkendő és némi mosogatószer vagy valamelyik ismert speciális ápolószer (nemesacél tisztító, Metall Polish) használata. Más anyagokból – pl. porcelán, műanyag, akril-kerámia – vagy nemesacélből készült beépített mosogatókhoz kímélő mosogató- vagy tisztítószer használjon.</p> <p>Kérjük, hogy ezenkívül a speciális gyártói ápolási tudnivalót is vegye figyelembe!</p> <p><b>Üvegkerámia főzőlapok:</b> A rozsdamentes acélből készült beépített mosogatók, főzőlapok és egyéb meg nem nevezett termékek ápolásának legkíméletesebb módja a szivacs vagy gyapjúkendő és némi mosogatószer vagy valamelyik ismert speciális ápolószer (nemesacél tisztító, Metall Polish) használata. Más anyagokból – pl. porcelán, műanyag, akril-kerámia – vagy nemesacélből készült beépített mosogatókhoz kímélő mosogató- vagy tisztítószer használjon.</p> <p>Kérjük, hogy ezenkívül a speciális gyártói ápolási tudnivalót is vegye figyelembe!</p>	
--	--

## HU Ápolási tudnivalók

<p><b>Műanyagfelületek:</b> A műanyag bevonatú felületek/frontok ápolása szokványos háztartási tisztítószerrel lehetséges. A legjobb a puha törökendő, langyos víz és némi mosogatószer használata. Ne használjon polírozó hatású tisztítószer vagy kemény szivacsot!</p> <p>A makacs foltok – pl. ráfőrcsönt zsír, lakk- vagy ragasztómaradványok – kereskedelemben kapható műanyagtisztítóval távolíthatók el. Az ilyen tisztítószerrek első használata előtt ajánlott próbát végezni egy nem látható helyen!</p> <p><b>Fényes frontok:</b> Az ilyen frontokat soha ne tisztítsa szárazon!</p> <p>A súroló hatású tisztítószerrek és -szkőzők (mikroszálás törökendők, súrolószivacsok stb.) használata fokozott karcosodást okoz, amit nem áll módunkban reklamáció alapjául elfogadni.</p> <p>Ezért a legjobb, ha pormentes törökendőt vagy ablaktisztító bőkendőt használ.</p> <p><b>Beépített mosogatók és főzőlapok:</b> A rozsdamentes acélből készült beépített mosogatók, főzőlapok és egyéb meg nem nevezett termékek ápolásának legkíméletesebb módja a szivacs vagy gyapjúkendő és némi mosogatószer vagy valamelyik ismert speciális ápolószer (nemesacél tisztító, Metall Polish) használata. Más anyagokból – pl. porcelán, műanyag, akril-kerámia – vagy nemesacélből készült beépített mosogatókhoz kímélő mosogató- vagy tisztítószer használjon.</p> <p>Kérjük, hogy ezenkívül a speciális gyártói ápolási tudnivalót is vegye figyelembe!</p> <p><b>Üvegkerámia főzőlapok:</b> A rozsdamentes acélből készült beépített mosogatók, főzőlapok és egyéb meg nem nevezett termékek ápolásának legkíméletesebb módja a szivacs vagy gyapjúkendő és némi mosogatószer vagy valamelyik ismert speciális ápolószer (nemesacél tisztító, Metall Polish) használata. Más anyagokból – pl. porcelán, műanyag, akril-kerámia – vagy nemesacélből készült beépített mosogatókhoz kímélő mosogató- vagy tisztítószer használjon.</p> <p>Kérjük, hogy ezenkívül a speciális gyártói ápolási tudnivalót is vegye figyelembe!</p> <p><b>Üvegkerámia főzőlapok:</b> A rozsdamentes acélből készült beépített mosogatók, főzőlapok és egyéb meg nem nevezett termékek ápolásának legkíméletesebb módja a szivacs vagy gyapjúkendő és némi mosogatószer vagy valamelyik ismert speciális ápolószer (nemesacél tisztító, Metall Polish) használata. Más anyagokból – pl. porcelán, műanyag, akril-kerámia – vagy nemesacélből készült beépített mosogatókhoz kímélő mosogató- vagy tisztítószer használjon.</p> <p>Kérjük, hogy ezenkívül a speciális gyártói ápolási tudnivalót is vegye figyelembe!</p>	
--	--

<p><b>TR Bakım uyarıları</b></p> <p><b>Plastik yüzeyler:</b> Plastik kaplı yüzeyler/ön paneller sıradan temizlik maddeleriyle temizlenebilir. Bunun için yumuşak bir bez, ilik su ve biraz deterjan kullanın. Parlaklı temizlik maddeleri veya sert süngerler kullanmayın! Yağ artıkları, boya veya yapışkan artıkları gibi zor lekeler i sıradan bir plastik temizleyicileri temizleyin. Bu maddeleri ilk kez kullanmadan önce bunları önce görünmeyen bir yerde test etmeniz öneriyoruz!</p> <p><b>Parlak ön paneller:</b> Bu panelleri asla kuru şekilde temizlemeyin!</p> <p>Aşındırıcı temizlik maddelerinin kullanılması (mikro elyaflı bezler, bulaşık tell vs.) daha fazla çizilge neden olurlar ve şikayet nedeni olarak geçerli değildirler. Bu nedenle tozsuz bir bez veya nemli bir güdelt bez kullanın.</p> <p><b>Ankastre evye ve ocak gözleri:</b> Ankastre evyeler, ocak gözleri ve paslanmaz çelkten yapılmış bahsi geçmeyen diğer ürünler bir süngerle veya bir keçe ile bezle deterjan kullanarak temizleyin (paslanmaz çelik temizleyici, Metall-Polish). Porselen, plastik, akril seramik gibi maddelerden yapılmış evyelerde ve paslanmaz çelik evyelerde yumuşak deterjan kullanın.</p> <p>Аyrıca üreticinin özel bakım uyarılarını dikkate alın!</p> <p><b>Cam seramik ocaklar:</b> Zorlu kirlet, kireç ve su lekelerini üreticinin tavsiye ettiği mzel temizleyicileri temizleyin (ör. Cerafix, Stahlfix). Yanmış kirler (şeker, tuz veya şeker içeren yemek artıkları) sıcak durumdayken bir cam raspayla çıkarın. Bununla ilgili cihaz üreticisinin kullanım kılavuzunu dikkate alın!</p> <p><b>Tutamaklar:</b> Solvent madde içeren, alüminyuma zarar veren maddelerden, sıkke içeren maddelerden kaçının; bunlar kalıcı lekelere yol açabilirler.</p>	
--	--

<p><b>PL Wskazówki do pielęgnacji</b></p> <p><b>Powierzchnie z tworzyw sztucznych:</b> Powierzchnie powlekane tworzywami sztucznymi można pielęgnować zwykłymi środkami myjącymi, jakie są używane w gospodarstwie domowym. Najlepiej nadaje się do tego miękka ściereczka, letnia woda i nieco środka myjącego. Nie używać środków do polerowania ani twardych gąbek! Uporczywe plamy, np. tłuszczu, resztki lakieru lub taśmy klejącej, usuwać dosiępnymi w handlu środkami do czyszczenia tworzyw sztucznych. Przed pierwszych ich użyciem zaleca się wypróbowanie w niewidocznym miejscu!</p> <p><b>Strony czolowe z polysklem:</b> Tych części nigdy nie czyścić na sucho!</p> <p>Używanie ściągających środków czyszczących (ściereczki z mikrofazy, gąbki do szorowania itd.) może prowadzić do nasilonego powstawania rys i nie stanowi podstawy do reklamacji. Dlatego najlepiej jest stosować ściereczkę wolną od pytu lub wilgotną skórę do czyszczenia okien.</p> <p><b>Wbudowywane zlewozmywaki i wnęki kuchenne:</b> Wbudowywane zlewozmywaki, wnęki kuchenne, jak też wszystkie niewymienione artykuły ze stali nierdzewnej najlepiej jest pielęgnować gąbką lub ściereczką z włókniny i płysnem do mycia lub znanym środkiem specjalnym do pielęgnacji (do czyszczenia stali szlachetnej, polerowania metali). W przypadku zlewozmywaków z innych materiałów, jak porcelana, tworzywo sztuczne, ceramika akrylowa lub ze stali szlachetnej stosować łagodne środki myjące lub czyszczące. Prosimy poza tym stosować się do szczególnych instrukcji producenta!</p> <p><b>Ceramizna płyta kuchenna:</b> Uporczywe zabrudzenia, osady kamienia i zacieki jak też blyszczące odbicie garnków usuwać specjalnym środkiem zalecanym przez producenta (np. Cerafix, Stahlfix). Nadpalone resztki (cukier, sól, resztki zawierające cukier) usuwać, w stanie jeszcze gorącym, dołączonym skrobakiem szklanym.Stosować się przy tym także do Instrukcji producenta urządzenia!</p> <p><b>Uchwyty:</b> Zrezygnować z substancji zawierających rozpuszczalniki i szkodliwych dla aluminium, jak też na bazie octu, gdyż mogą one prowadzić do powstawana nieusuwalnych plam.</p>	
--	--

<p><b>CZ Pokyny z umývání hmoty:</b> Povrchy z umělého úpravou z umelej hmoty/čelné plochy je možné ošetřovat pomocí čističích prostředků běžných v domácnosti. Nejlepší to lde měkkou hadříčkou, vlažnou vodou a nepatrným množstvom prostředku na umývanie. Nepoužívajte leštidla čistiace prostriedky ani tvrdé špongie! Zadržnuté škvrny, ako rozstreky oleja, zvyšky laku alebo lepidla, sa musia odstrániť pomocou čistiacich prostriedkov bežných v domácnosti. Pred prvým použitím týchto prostriedkov sa odporúča prekontrolovať pôsobenie na nejakom mieste, ktoré nie je vidieť!</p> <p><b>Lesklé čelné plochy:</b> Tieto čelné plochy nikdy nečistíte nasucho!</p> <p>Použitie brúsiacich čističích prostriedkov (úterky z mikrovlákna, špongie na drhnutie atď.) môžu viesť ku zvýšenému tvoreniu škrabancov a tieto nie je dôvodom na reklamáciu. Preto používajte hadrítku bez prľfomnosti prachu alebo vlhkú kožu na čistenie skiel.</p> <p><b>Vestavane úmyvadlá a sporáky:</b> Vstavane úmyvadlá, sporáky, ako aj všetky neuvedené výrobky z nehrdzavjúcej ocele ošetríte pomocou špongie alebo úterky z rúna za použitia prostriedku na umývanie alebo pomocou známych špeciálnych čističích prostriedkov (čističá prostriedkov na ušľachtílu oceľ, polítura na kov). Pri vstavanych úmyvadlách z iných materiálov, ako porcelán, umelá hmota, akryl keramiká, ako aj pri úmyvadlách z ušľachtilej ocele používajte jemné čistacie prostriedky alebo prostriedky na umývanie.</p> <p>Okrem toho dodržiavajte špeciálne pokyny k ošetrovaniu od výrobcu!</p> <p><b>Sklokeramické platne:</b> Zadržnuté znečistená, flaky z vodného kameňa a vody, ako aj lesklý oder z hrncov odstraňujte pomocou špeciálneho čističa odporúčaného výrobcem (napr. Cerafix, Stahlfix). Zapečené inkrustácie (cukor, soľ alebo zvyšky jedla s obsahom cukru) odstraňujte ešte v horúcom stave pomocou príložené škrabky na sklo.</p> <p>Príhľadajte pritom aj na návod na obsluhu od výrobcu spotrebiča!</p> <p><b>Úchyty:</b> Zrekltnite sa substancií s obsahom rozpúšťadla a substancií poškodzujúcich hliník, ako aj octových čistiacich prostriedkov, pretože tieto môžu viesť k už neodstraniteľným škvrám</p>	
---	--

<p><b>RO Indicații de îngrijire</b></p> <p><b>Suprafețele din plastic :</b> Suprafețele/suprafețele frontale cu strat de acoperire din plastic pot fi îngrijite cu agenți de curățare casnicl uzuali. Cea mai bună soluție este cu o cârpă moale , apă caldă și puțin detergent. Nu utilizați substanțe de curățare abrazive sau bureți tari ! Pielele persistente, cum sunt stropii de uscare, resturile de vopsea sau adeziv, se vor înlătura cu un detergant uzual din cu merit pentru plastic. Înainte de prima utilizare a acestei substanțe, se recomandă verificarea ei într-un loc mai puțin vizibil !</p> <p><b>Suprafețele frontale strălucitoare :</b> Nu curățați niciodată uscat aceste suprafețe fronta le! Utilizarea unor mijloace abrazive de curățare (cârpă cu microfibre, bureți pentru frecat etc.) pot duce la formarea unor zgârieturi și nu constituie un motiv pentru reclamații . De aceea, cel mai bine este să curățați cu o cârpă moale, să folosiți un detergant uzual din cu merit pentru plastic. Înainte de prima utilizare a acesrei substanțe, se recomandă verificarea ei într-un loc mai puțin vizibil !</p> <p><b>Chivetele Incorporate și locașul pentru plite:</b> Chivetele încorporate, locașurile pentru plite, precum și toate articolele care nu sunt menționate din ojel oxidizabil pot fi îngrijite optim cu un burete sau cu o cârpă textilă, utilizând un agent de spălare sau agenții de îngrijire cunoscuți (detergenți pentru inox, agenți de lustrul metal). In cazul chivetelor încorporate din alte materiale cum sunt porțelanul, plasticul, ceramica acrilică, precum și In cazul chivetelor din inox, utilizați agenții de spălare sau de curățare neagresivi . Vă rugăm să acordați atenție, suplimentar, indicațiilor speciale de îngrijire emise de producător !</p> <p><b>Ochiluri de plită din sticlă ceramică :</b> Murdăria persistentă , petele de calcar și apă, precum și urmele strălucitoare lăstate de vase se înlătură cu agenții de curățare special recomandați de producător (de ex. Cerafix, Stahlfix). Crustele aderente de arsuri (zahăr, sare sau resturi de alimente care conțin zahăr ) se înlătură In starea încă fierbinte cu o racletă pentru sticlă. In acest sens, respectați manualul de utilizare editat de producătorul aparatului !</p> <p><b>Măner:</b> Renunțați la substanțele care conțin solventi și care deteriorează aluminiul, precum și la substanțele de curățare pe bază de oțet, deoarece acestea pot forma pete care nu se mai înlătură .</p>	
--	--

<p><b>RU Указания по уходу</b></p> <p><b>Пластиковые поверхности:</b> Поверхности/фронтальные поверхности с пластиковым покрытием можно очищать обычными бытовыми чистящими средствами. Рекомендуется использовать мягкую салфетку, смоченную в теплой воде с добавлением средства для мытья посуды. Не используйте полирующие чистящие средства или жесткие губки! Стойкие пятна, такие как брызги жира, остатки краски или клея, удаляются с помощью обычных средств для чистки пластиковых поверхностей. Перед первым использованием средства рекомендуется проверить его, нанеся небольшое количество на незаметный участок.</p> <p><b>Глянцевые фронтальные поверхности:</b> Для таких поверхностей категорически запрещена сухая чистка! Использование полирующих чистящих средств (салфетка из микроволокна, мощных губок и т. л.) может привести к возникновению царапин. Такие повреждения поверхности не являются причиной для рекламации. Поэтому используйте чистую непьюльную салфетку или увлажненную замшу для чистки оков.</p> <p><b>Встроенные раковины и плиты:</b> Для ухода за встроенными раковинами и плитами, а также за прочими изделиями из нержавеющей стали рекомендуется использовать губку или флисовую салфетку и средство для мытья посуды или известные средства для чистки и полировки изделий из нержавеющей стали. Для очистки встроенных раковин из других материалов, таких как фарфор, пластик, акриловая керамика, а также раковин из высококачественной стали используются мягкие моющие и чистящие средства.</p> <p>Кроме того, следует учитывать рекомендации производителя по уходу.</p> <p><b>Степкокерамические варочные поверхности:</b> Стойкие загрязнения, такие как известковый налет и пятна от воды, а также блестящие металлические следы от кастрюль, устраняются с помощью специальных наплет и пятна от воды, а также блестящие металлические следы от кастрюль, устраняются с помощью специальных чистящих средств, рекомендованных производителем (например, Cerafix, Stahlfix). Пригоревшие пятна (сахар, соль или сахаросодержащие остатки пищи) удаляются горячими с помощью скребка для стеклокерамики.</p> <p>Учитывайте рекомендации производителя прибора, указанные в руководстве по эксплуатации.</p> <p><b>Ручки:</b> Не используйте вещества, повреждающие алюминий, а также чистящие средства, содержащие растворители и укус, так как они могут привести к образованию неудаляемых пятен.</p>	
--	--

500823.2.A 04/15 sl