

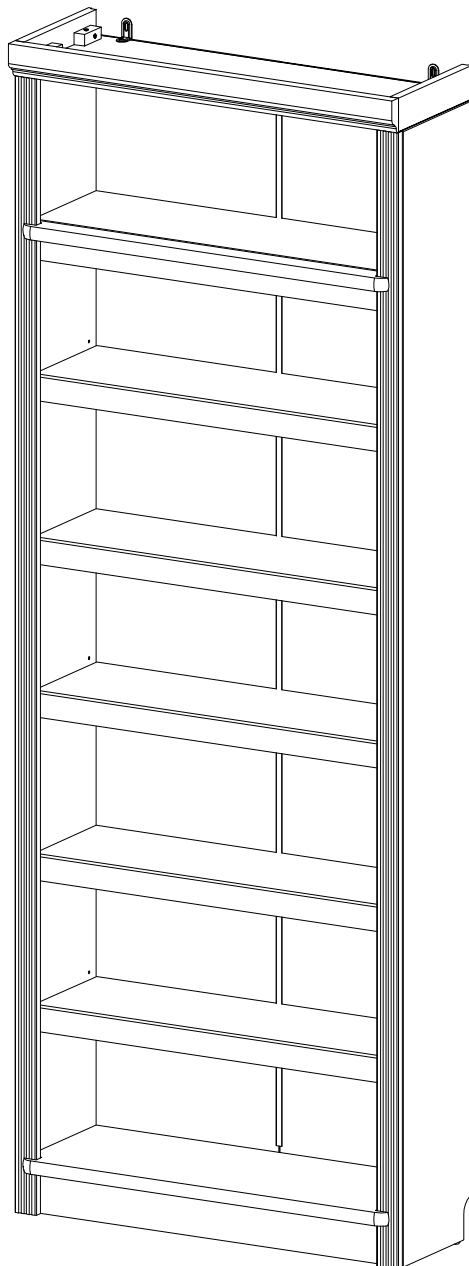

476056
Art. 431078
892881

LKZ 041332

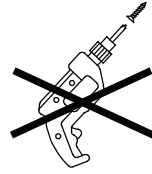
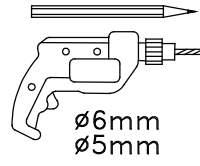
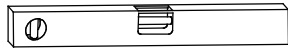
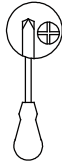
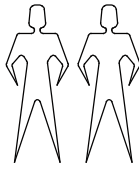

10442/5

Teil Nr. Pièces Nr. Pieces No. Часть Ном. Kawalek Nr. Parça No Kusú Nr. Kusov Nr. Pezzi Nr. Nr piese. Darab száma. Stukken Nr. Kārtas nr.	Anzahl Quantité Quantity Количество Ilość Miktar Množství Množstvo Quantità Cantitatea Mennyiség Hoeveelheid Skaitis	Kasten Nr. Colli Nr. Colli No. Коробка Ном. Polu Nr. Kutusu Nr. Kolonka Č. Počet balení Colli Nr. Nu pachete Colli száma. Colli Nr. Kastes nr.	Maß, mm Dimensions, mm Dimensions, mm Размеры, mm Wymiary, mm Boyutlar, mm Rozměry, mm Rozmery, mm Dimensioni, mm Dimensiuni, mm Méterek, mm Afmetingen, mm Izmēri, mm	
1	1	2/2	2126 x 250 x 18	
2	1	2/	2126 x 250 x 18	
4	1	1/2	762 x 80 x 18	
5	1	1/2	800 x 290 x 65	
6	5	1	762 x 45 x 18	
7	2	2/2	2126 x 45 x 18	
8	1	1	764 x 280 x 25	
9	3	1/2	762 x 227 x 18	
10	1	1/	764 x 65 x 18	
11	2	1/2	764 x 227 x 18	
12	2	2/	1169 x 390 x 4	
13	1	1	764 x 280 x 25	
14	2	2/	895 x 390 x 4	
15	1	1/	762 x 45 x 18	

10442/5

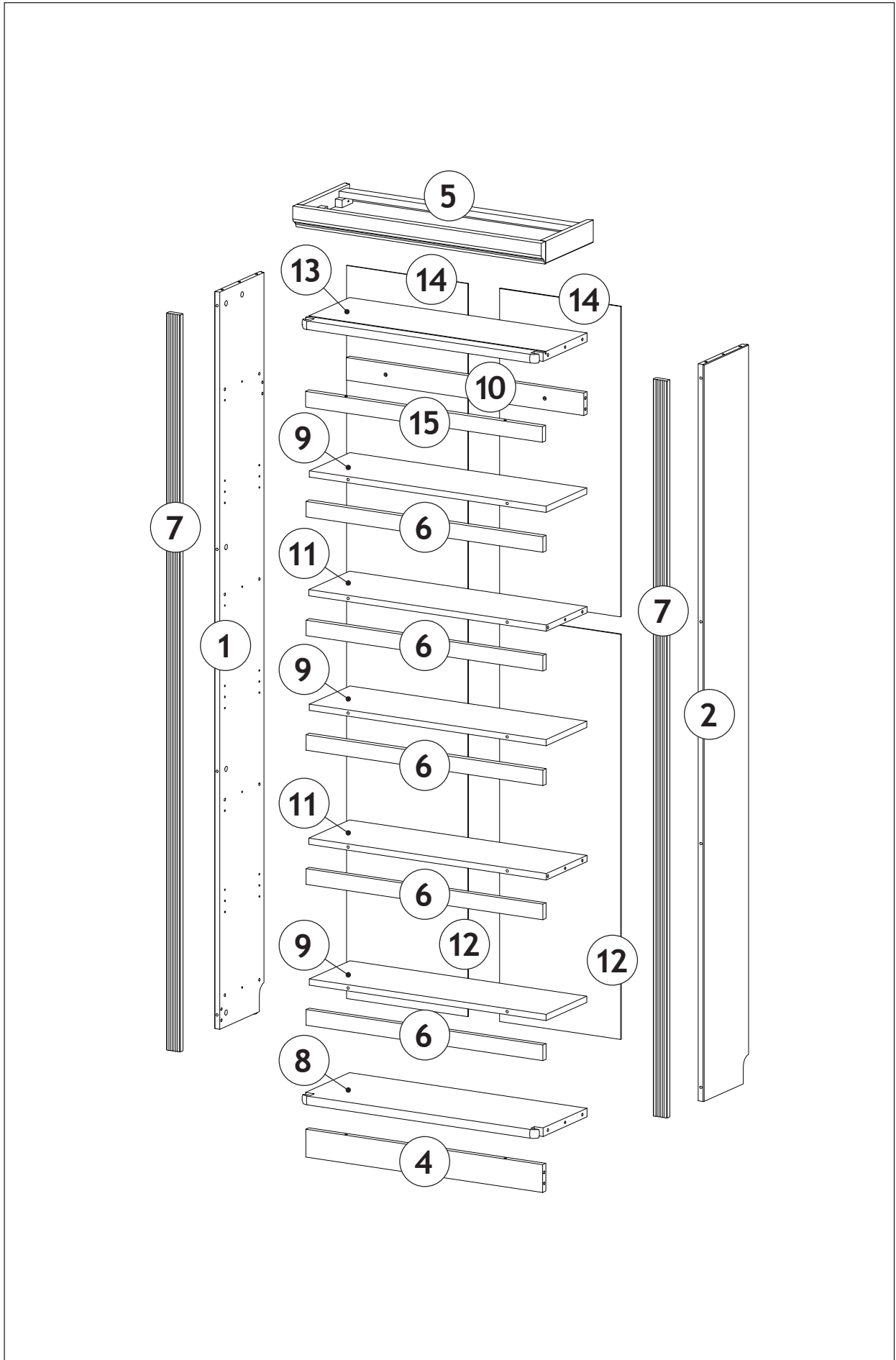

10442/5

**Service • Assistenza • Dienstverlening • Serwis
Servis • Szerviz • Сервисная служба**

Name • Nom • Nome • Naam •
Nazwa • Jméno • Názov • Név
Denumire • Isim • Название

Nr•No•N•Номер•Č•Sz

Typ•Type•Tip•Tipus•Тіро•Тип

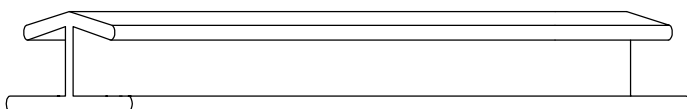
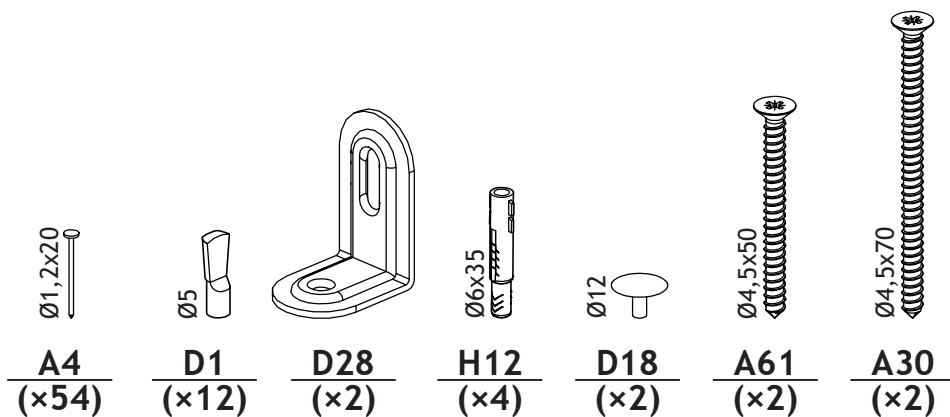
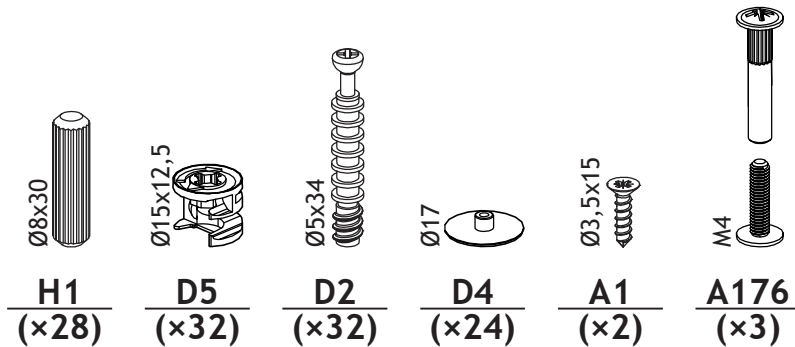
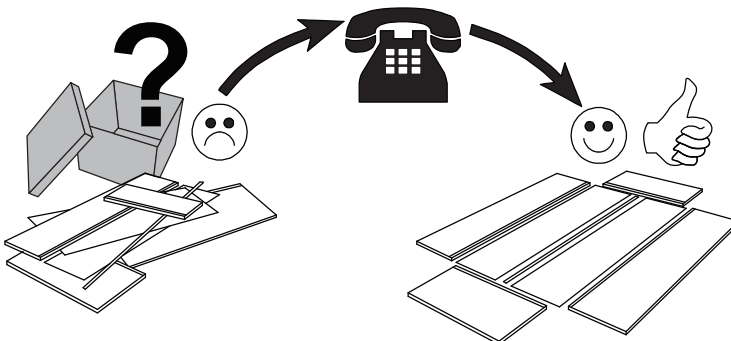
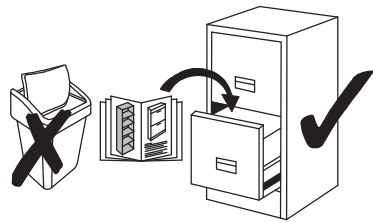

$\frac{K1}{(x1)}$
1132mm

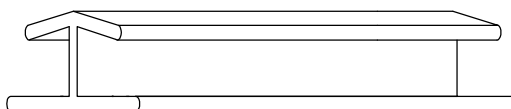



$\frac{K1}{(x1)}$
867mm

10442/5

1

D2
(x8)

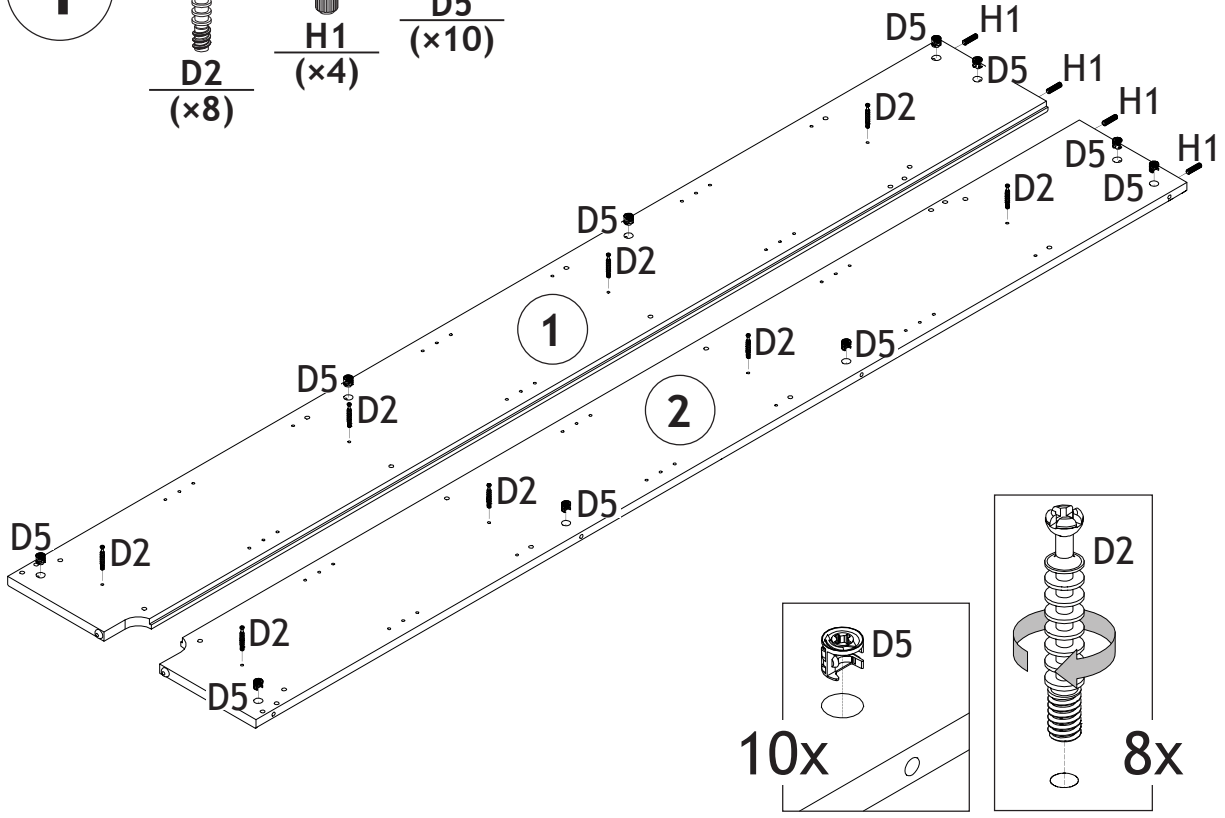

H1
(x4)

D5
(x10)

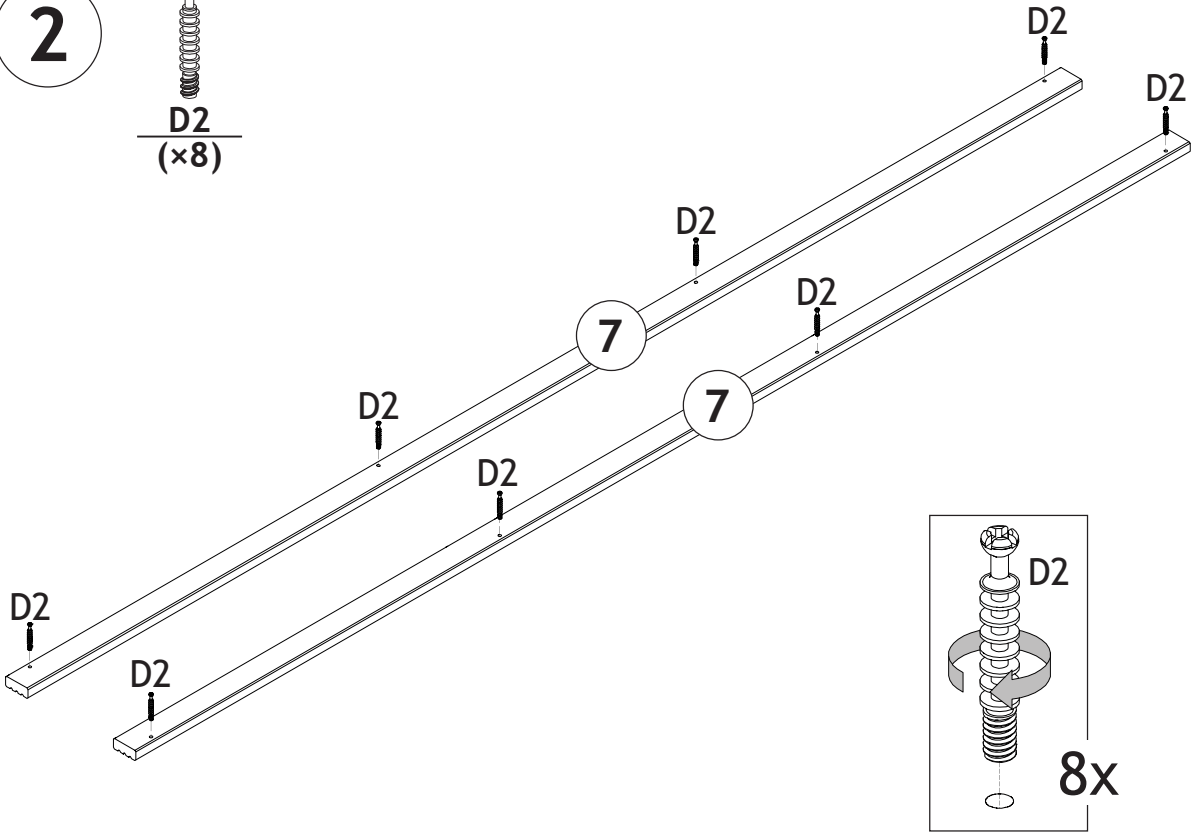

2

D2
(x8)



10442/5

3

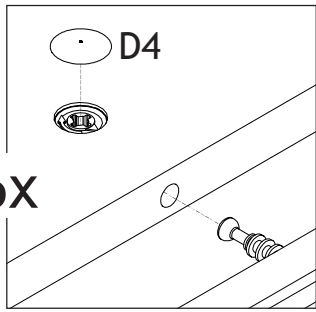

6x

D4
(x6)

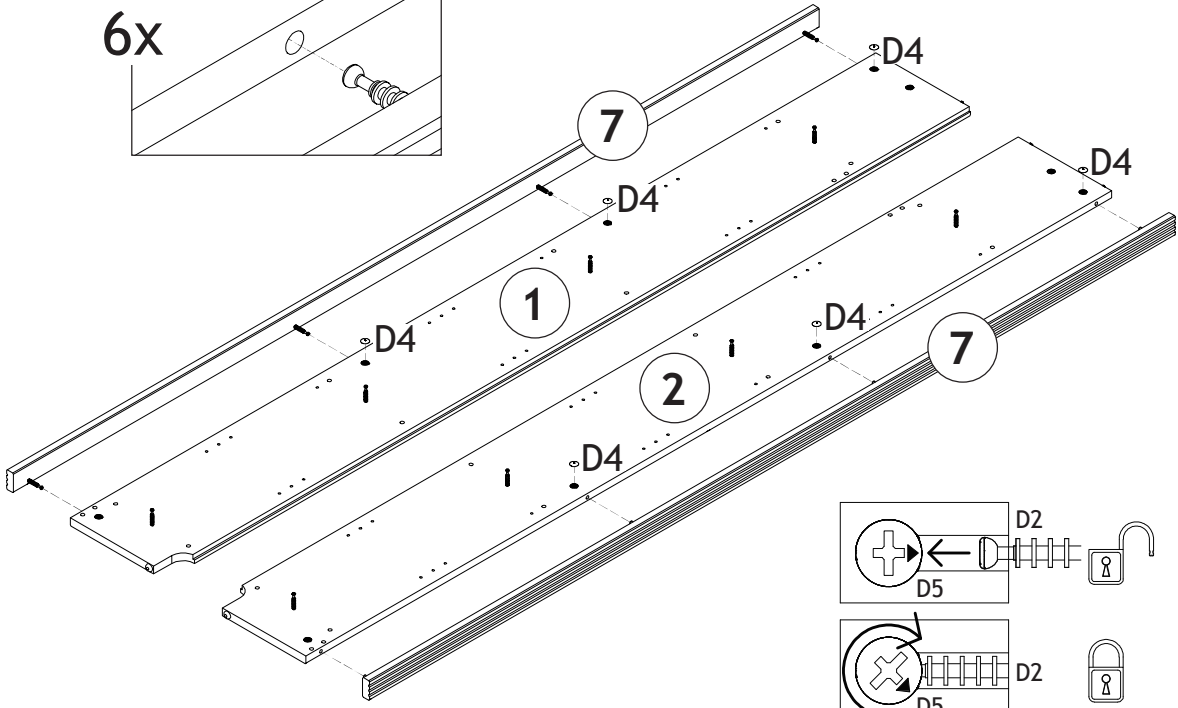

4

D5 (x4) H1 (x8) D2 (x2)

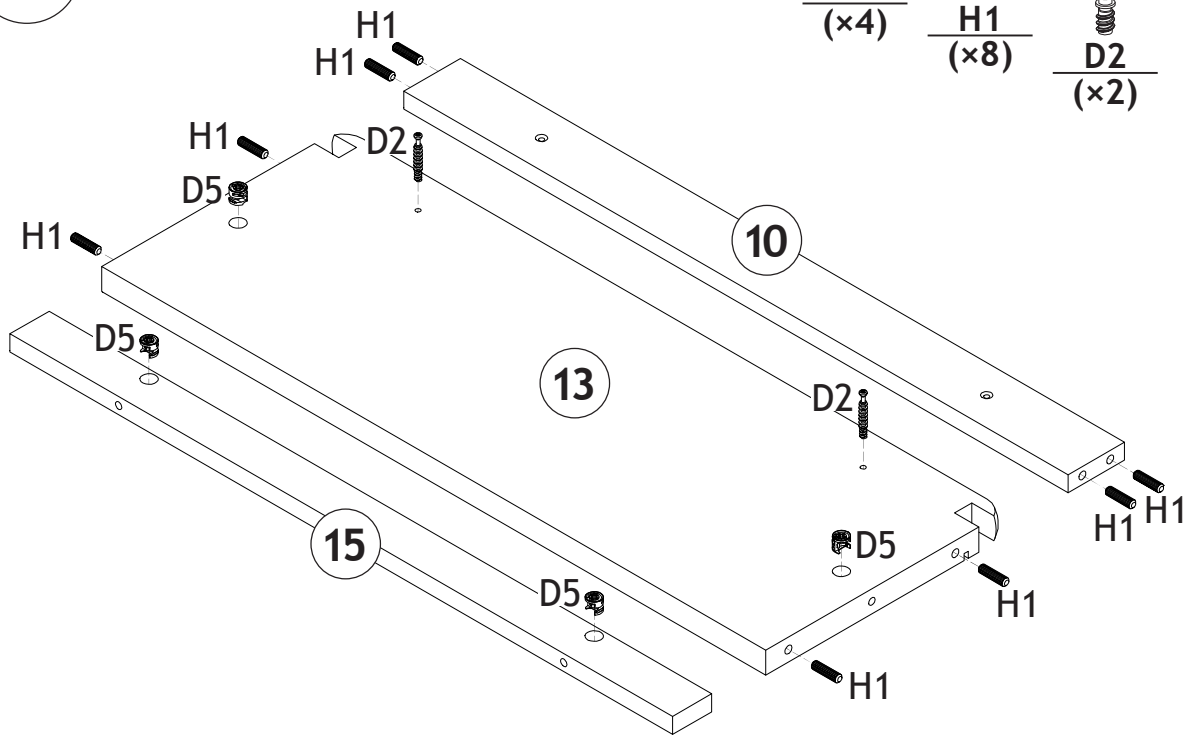



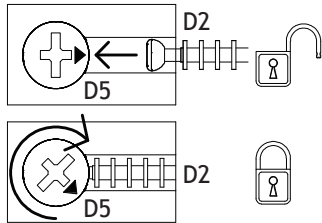
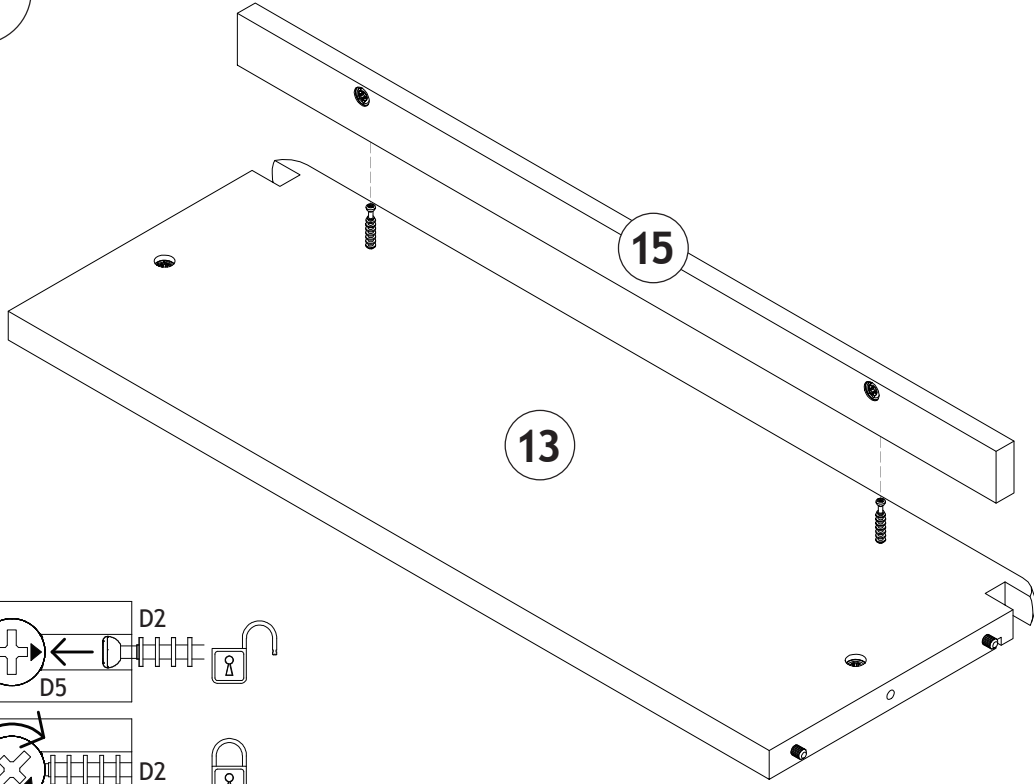

10442/5

5

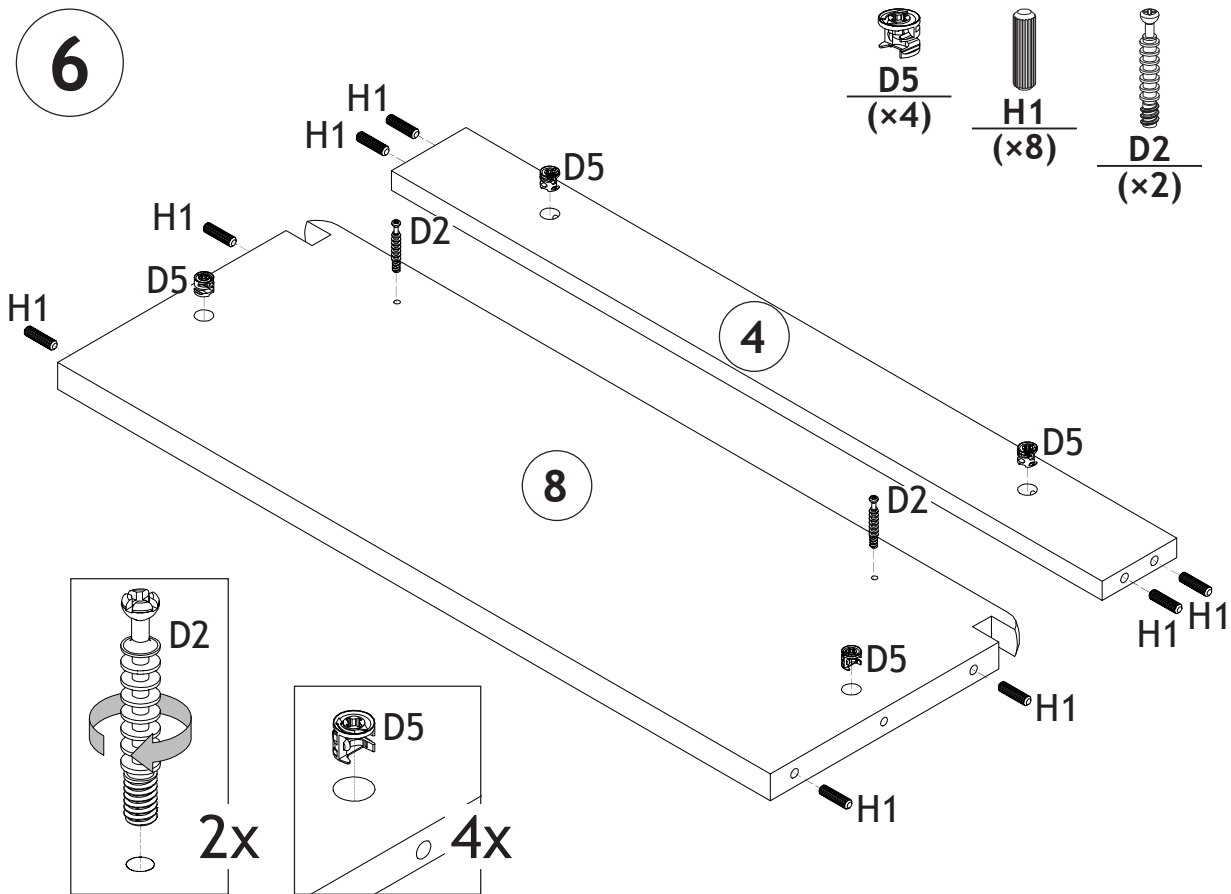

6



-  **D5**
(x4)
-  **H1**
(x8)
-  **D2**
(x2)

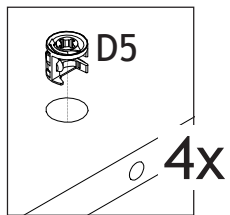
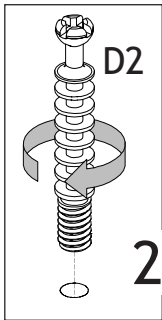

10442/5

7

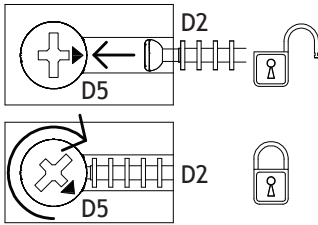
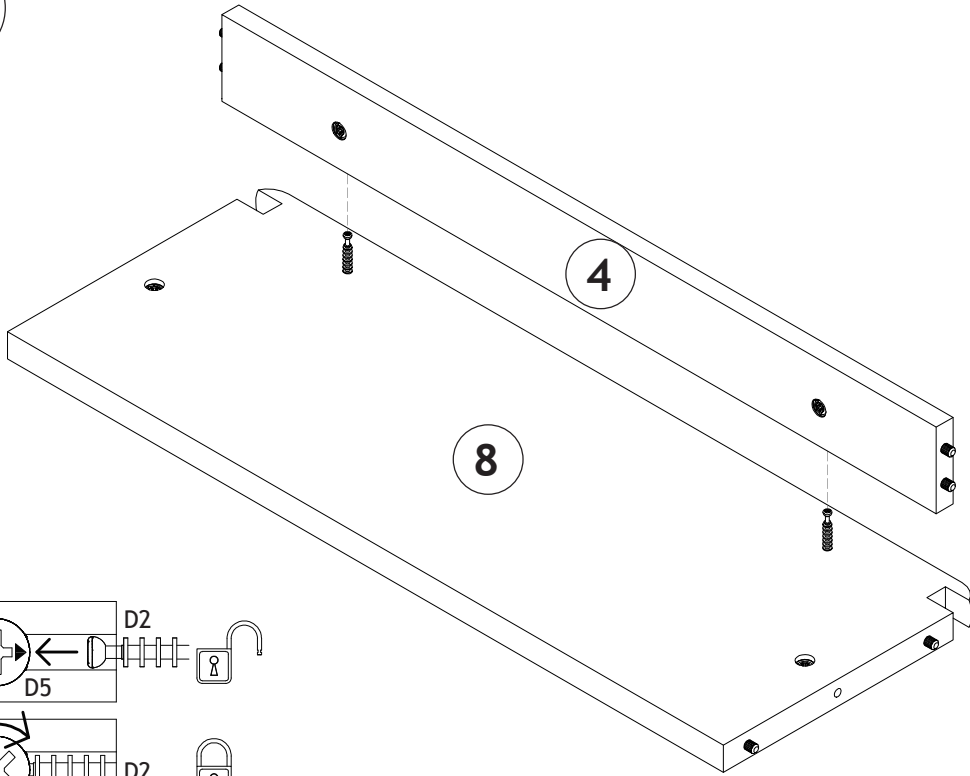

8

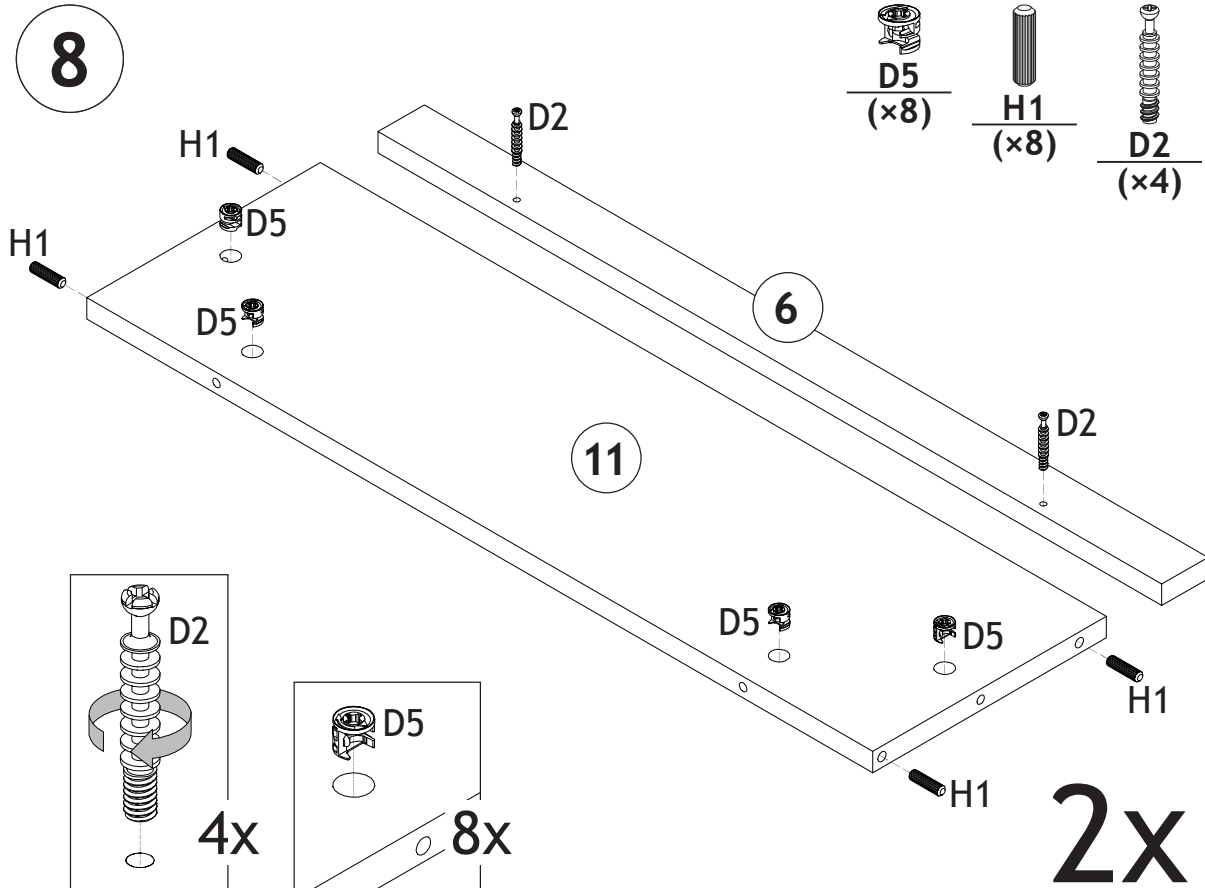

- D5 (x8)
- H1 (x8)
- D2 (x4)

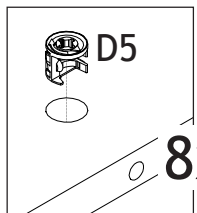
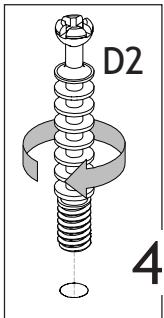

2x

10442/5

9

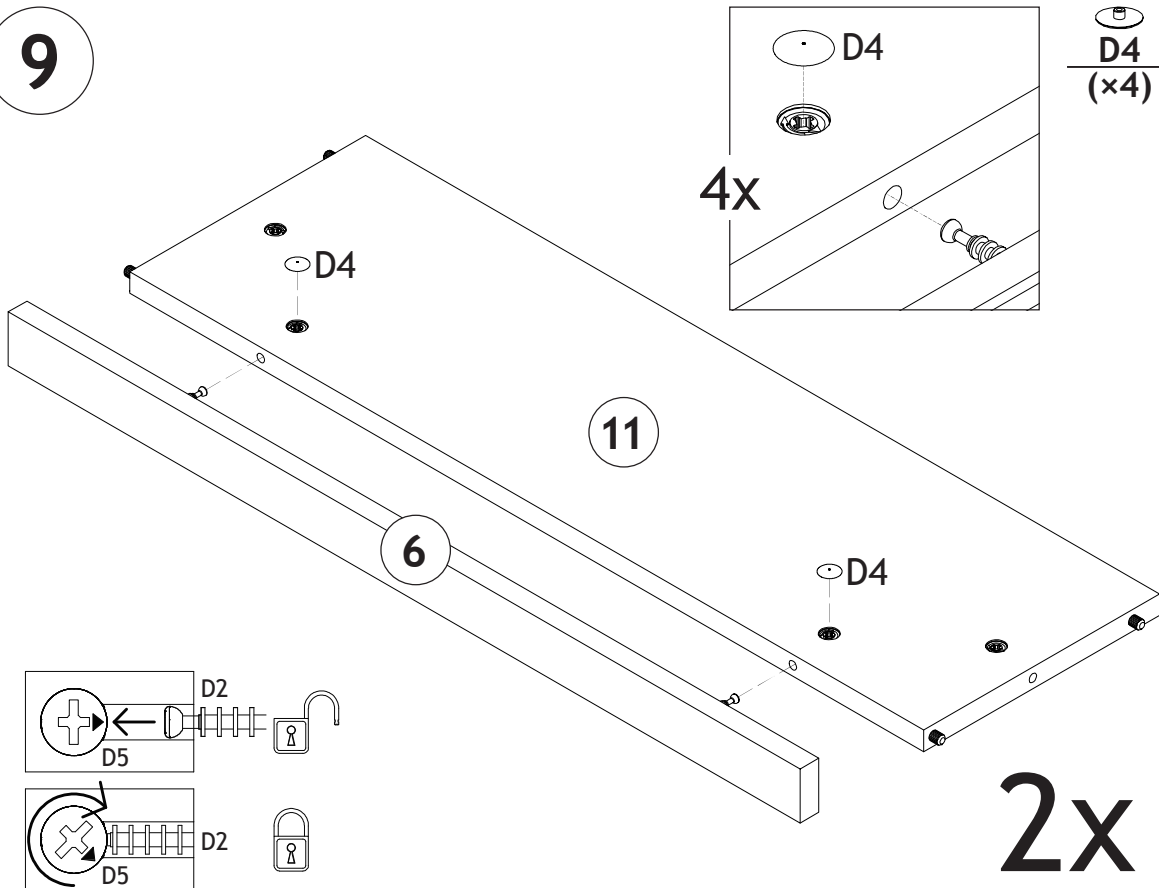

2x

10

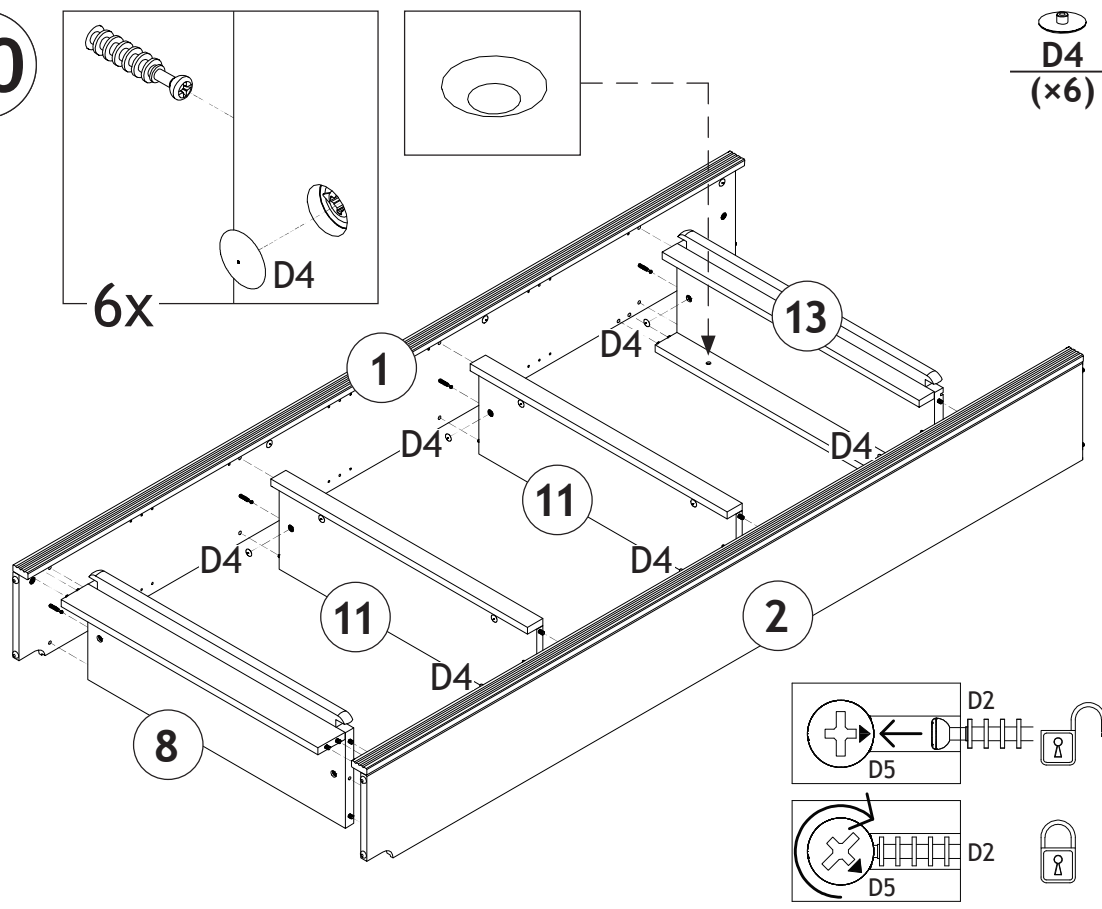

10442/5

11

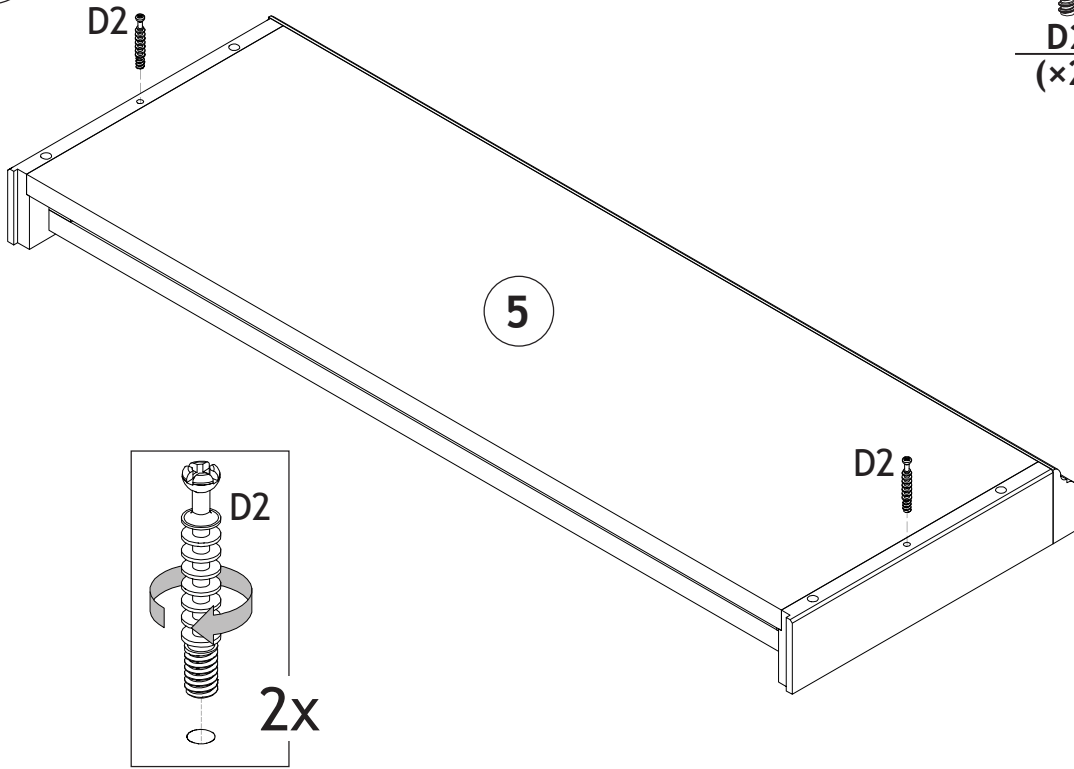

12

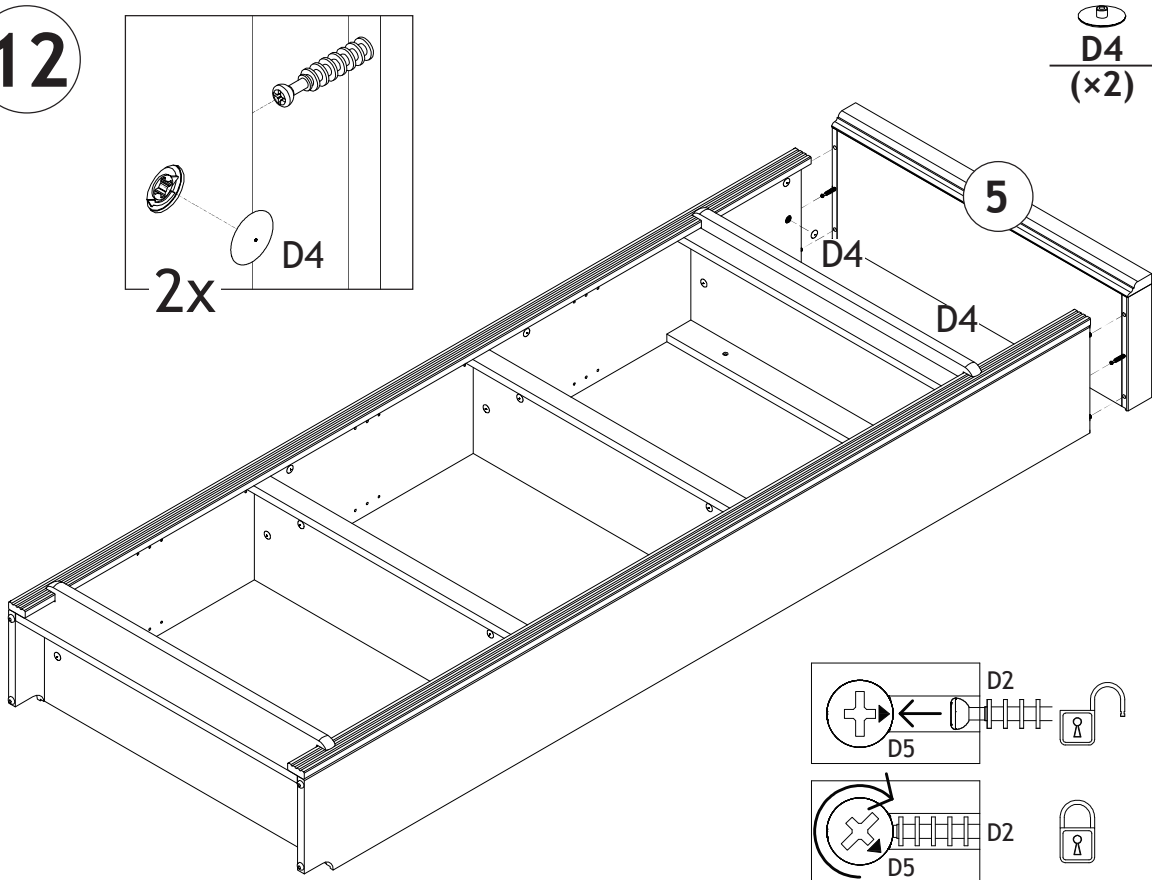

13

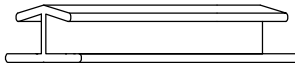

K1 L=1132mm
(x2) L=867mm

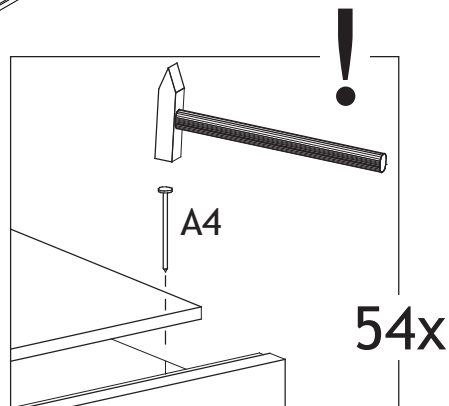
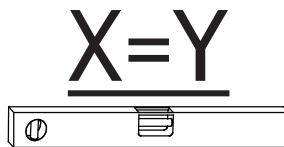
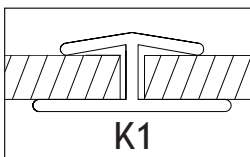
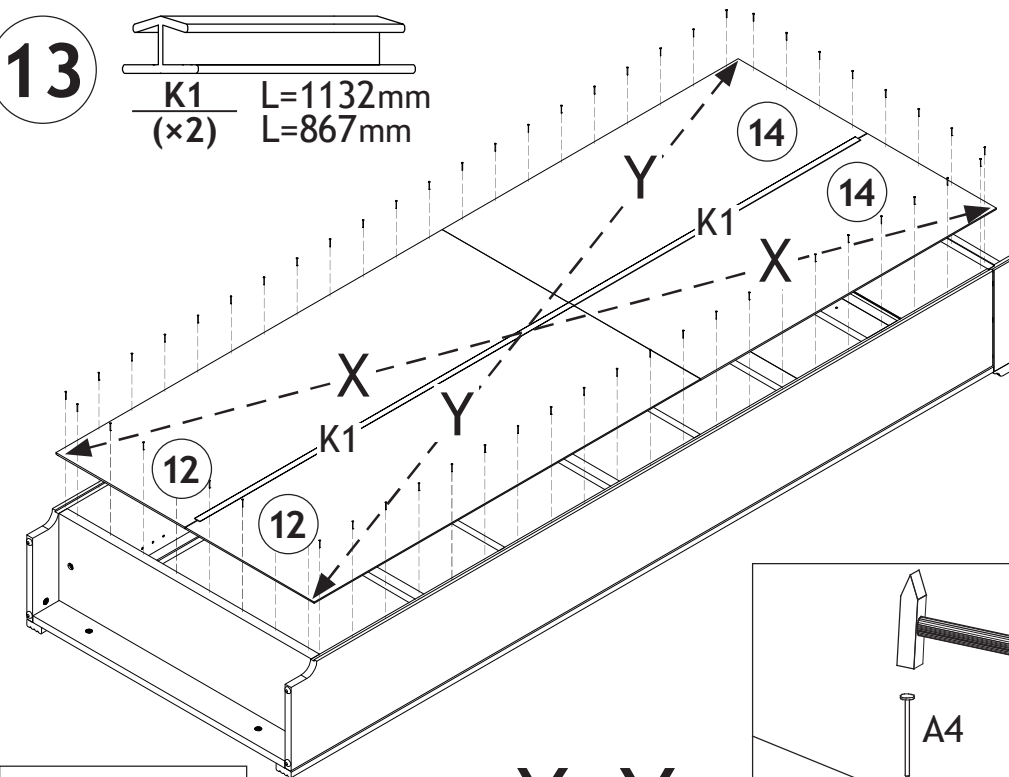

A4
(x54)



14

D18
(x2)



H12
(x2)

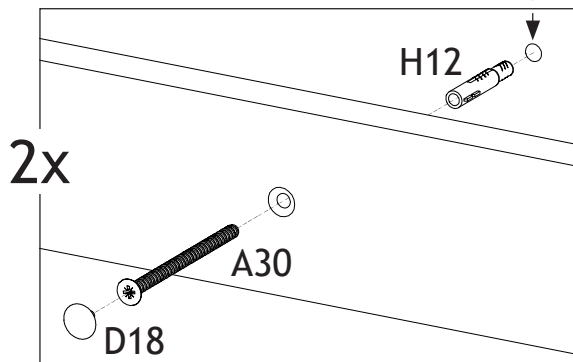
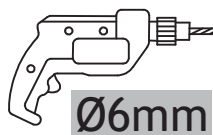
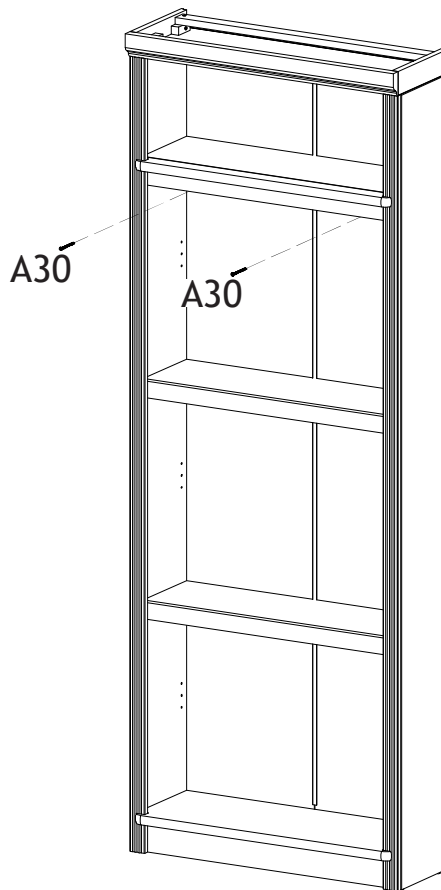

A30
(x2)

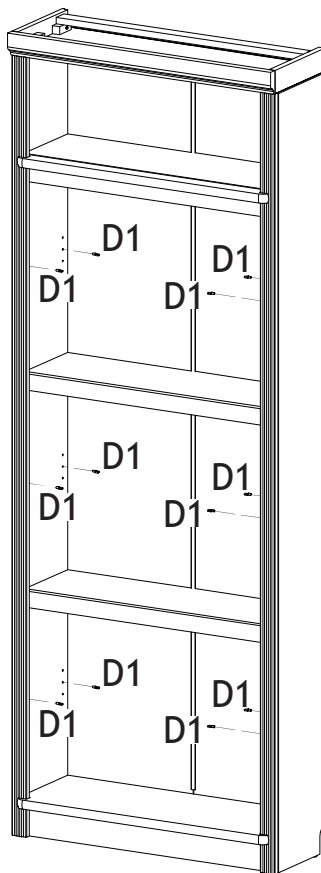
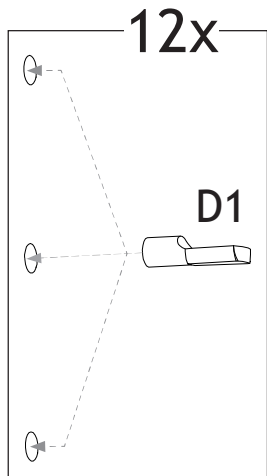

10442/5

15



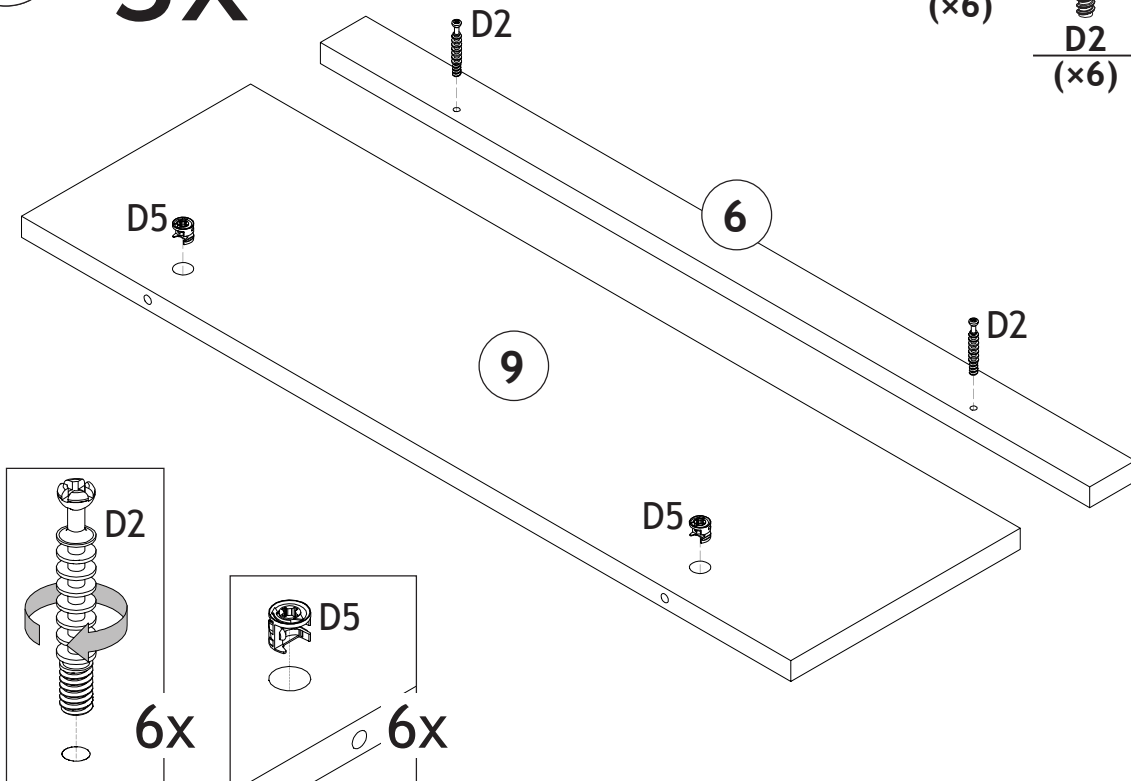

D1
(x12)

16 3x



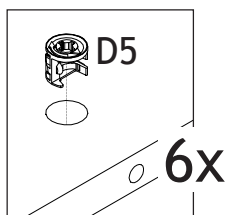
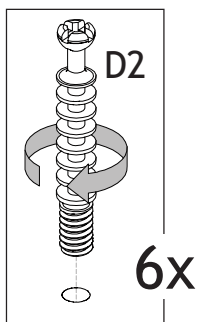

D5
(x6)

D2
(x6)

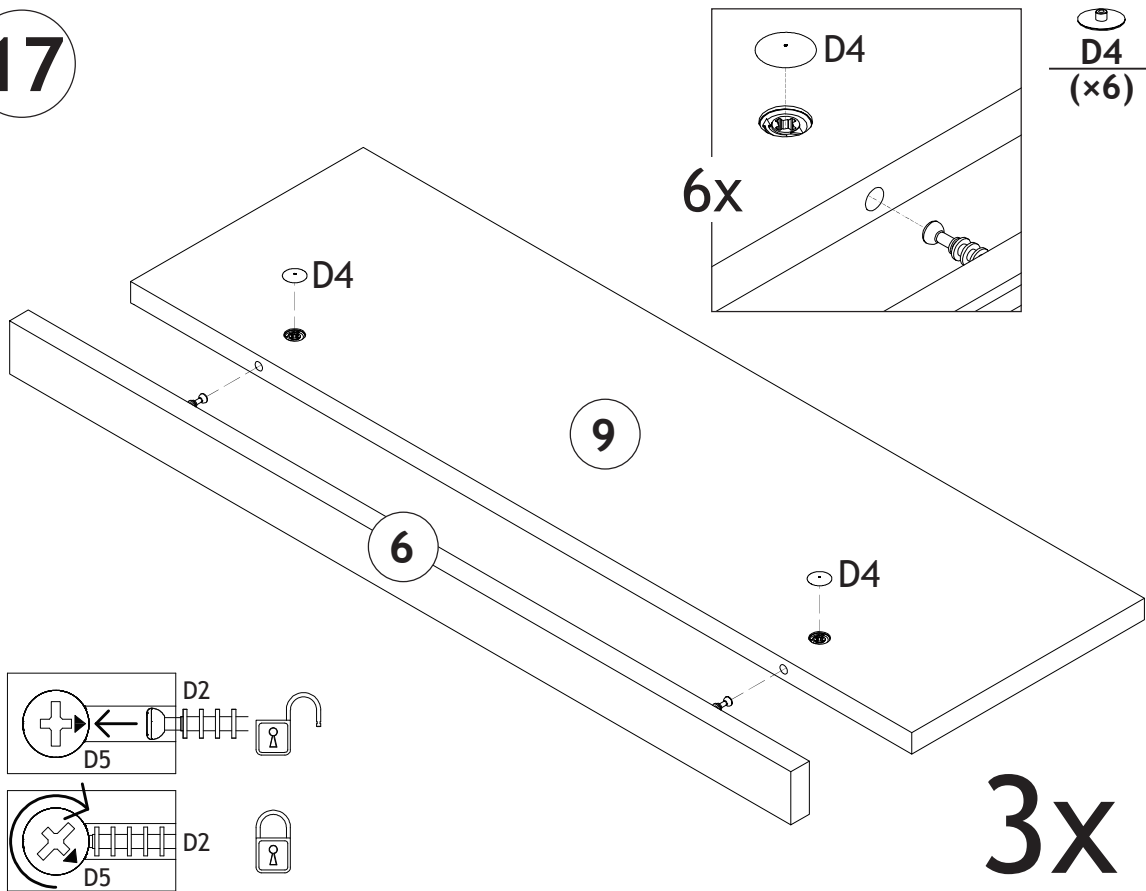

10442/5

17



18

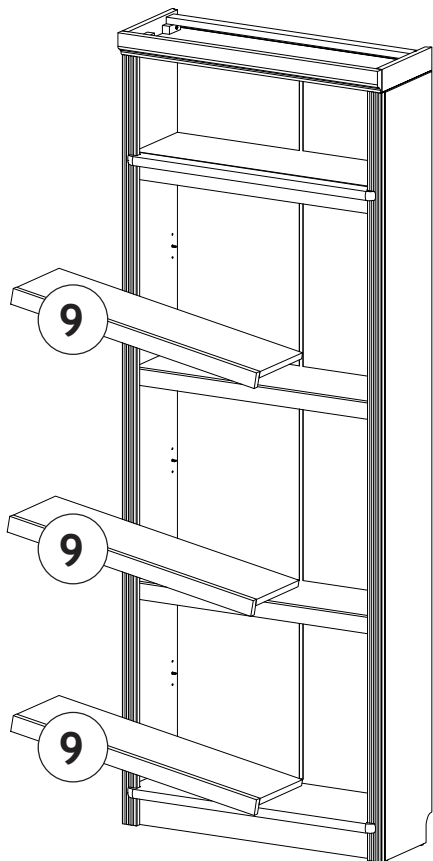

10442/5

19

A61
(x2)

H12
(x2)

D28
(x2)

A1
(x2)

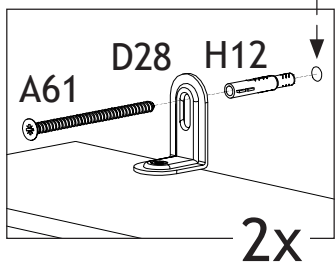
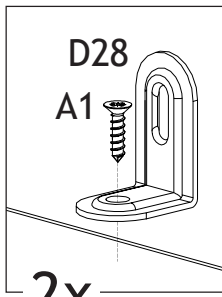

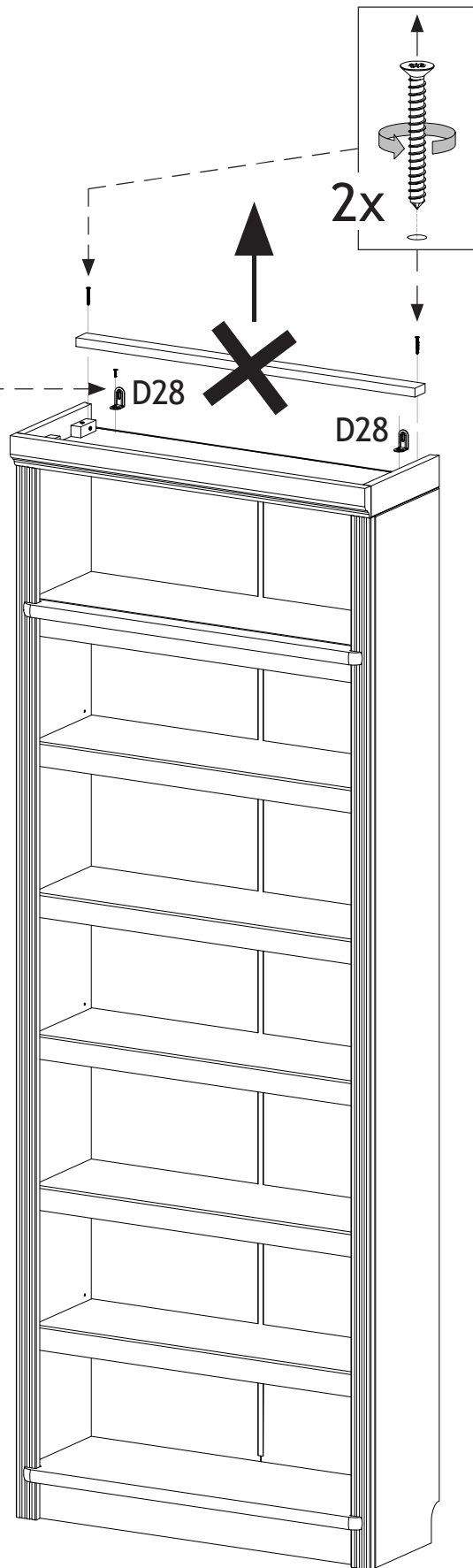

Ø6mm

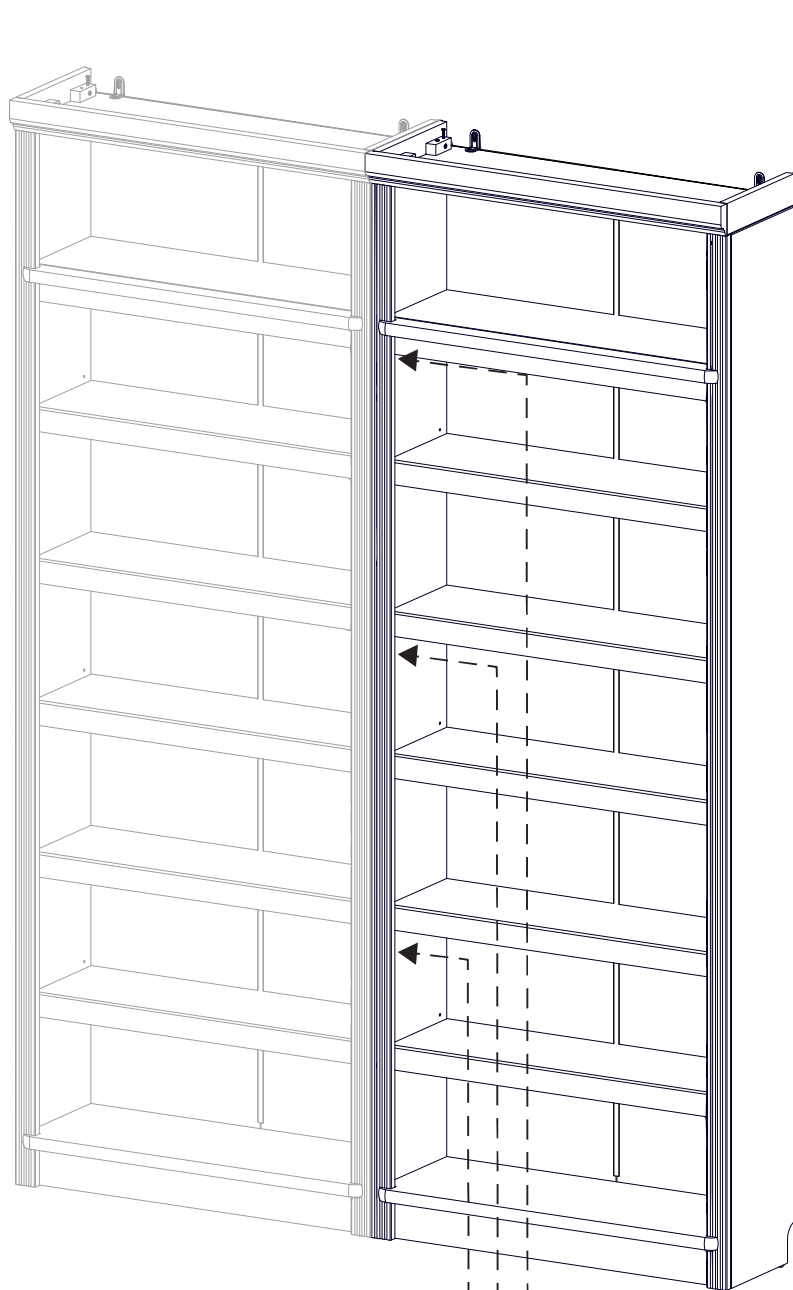

10442/5

20



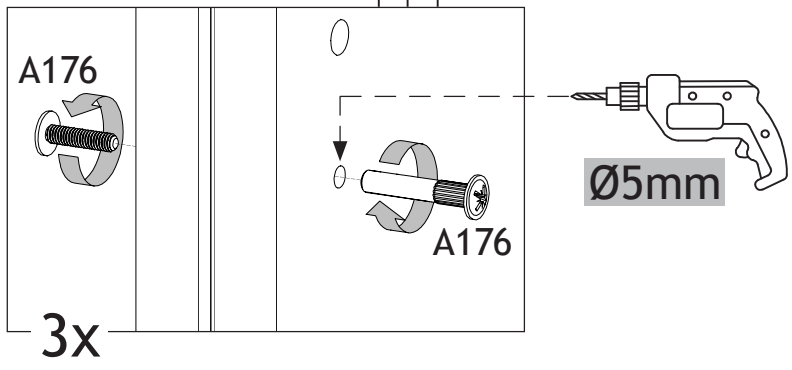

A176
(x3)



10442/5

H12  Ø6x35

A30  Ø4,5x50

A61  Ø4,5x50

 Ø6mm

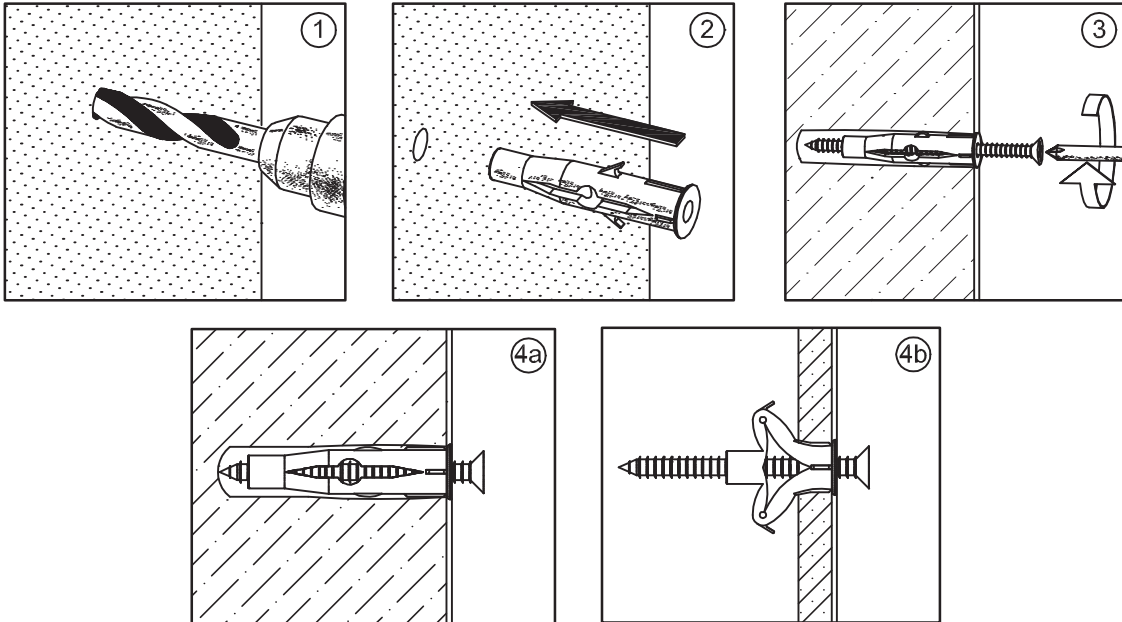

- D** **Achtung:** Die Befestigung des Möbelstückes an der Wand muss von einer fachkundigen Person vorgenommen werden, da für die Montage an die Wand angepasste Dübel erforderlich sind.
- GB** **Attention:** A qualified professional is required when mounting furniture to the wall since dowels corresponding to the wall are required for this.
- FR** **Attention:** La fixation du meuble contre le mur doit être effectuée par une personne compétente car, pour le montage mural, il faut utiliser des chevilles adaptées.
- IT** **Attenzione:** Il fissaggio del mobile alla parete deve essere eseguito da persone esperte, dato che occorrono tasselli adeguati.
- NL** **Opgelet:** een vakkundige persoon dient het meubelstuk aan de muur te bevestigen; voor de montage aan de muur zijn immers aangepaste pluggen vereist.
- PL** **Uwaga:** Mocowanie mebla do ściany mogą przeprowadzić wyłącznie wykwalifikowane osoby, z uwagi na zastosowanie odpowiednio dopasowanych kołków do rodzaju ściany.
- CZ** **Pozor:** Montáž nábytku na stěnu musí provést odborník, protože k montáži na stěnu jsou zapotřebí upravené hmoždinky.
- SK** **Pozor:** Upevnenie nábytku na stenu musí vykonať odborník, nakoľko súpre montáž na stenu potrebné vhodné hmoždinky.
- HU** **Figyelem:** A bútorlemez falra rögzítését szakembernek kell végeznie, mert a rögzítéshez megfelelő tiplit kell használni.
- RO** **Atenție:** Fixarea la perete a piesei de mobilier se realizează numai de către personal competent, deoarece montajul de perete necesită dibluri adecvate.
- TR** **Dikkat:** Mobilya parçasının duvara sabitlenmesi, duvar montajı için özel uyarlanmış dübeller gerektirdiğinden bu iş sadece bu konuda uzman bir kişi tarafından gerçekleştirilmelidir.
- RU** **Внимание:** Поскольку для монтажа на стене необходимо использовать специальные дюбели, мебель должна быть закреплена на стене квалифицированным персоналом.

10442/5