

AUFBAUANLEITUNG

Maximale Belastung :150 kg

Artikel Nr.101991

Ⓐ x 01 pc

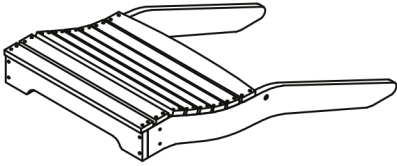

Ⓑ x 01 pc

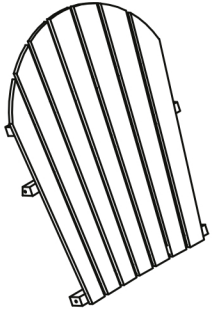

Ⓒ x 02 pcs (R-L)

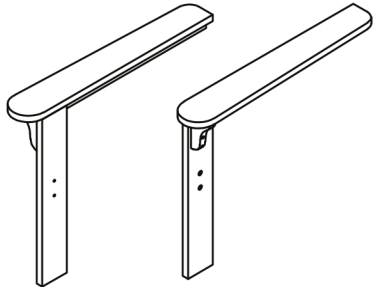

① M6x50
(04 pcs)



② M6x35
(04 pcs)

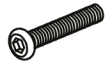

③ M6x13
(04 pcs)



④ M6x13
(04 pcs)



⑤ M6x20
(04 pcs)



⑥ M4 (02 pcs)



Schritt 1:

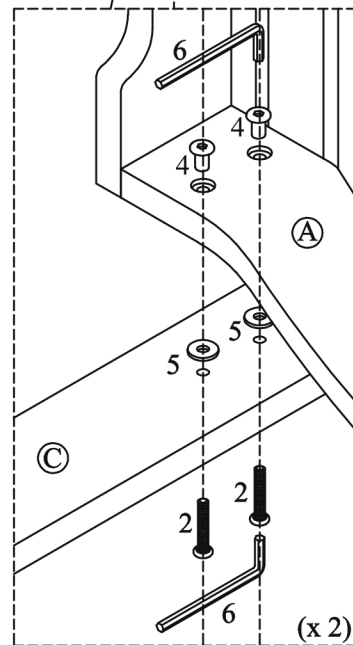
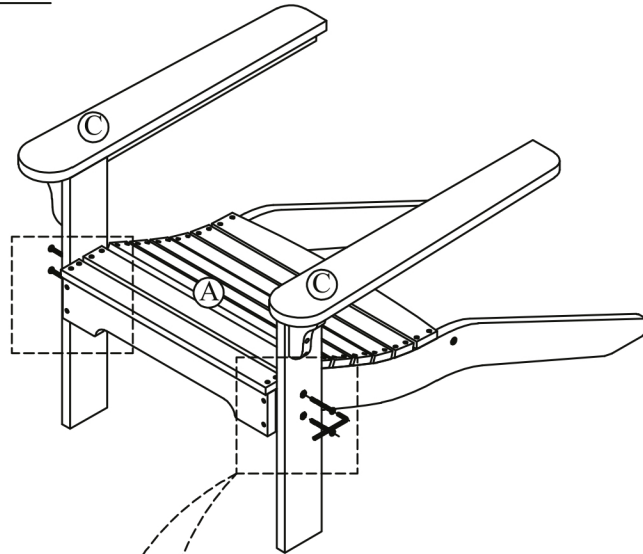

Schritt 2:

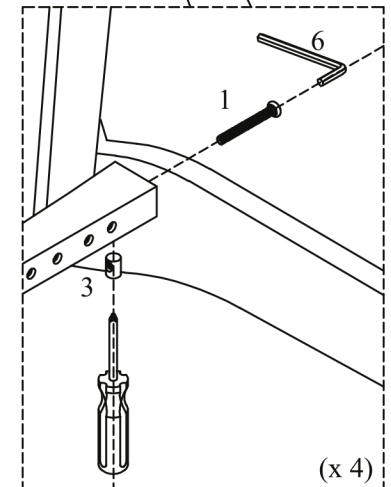
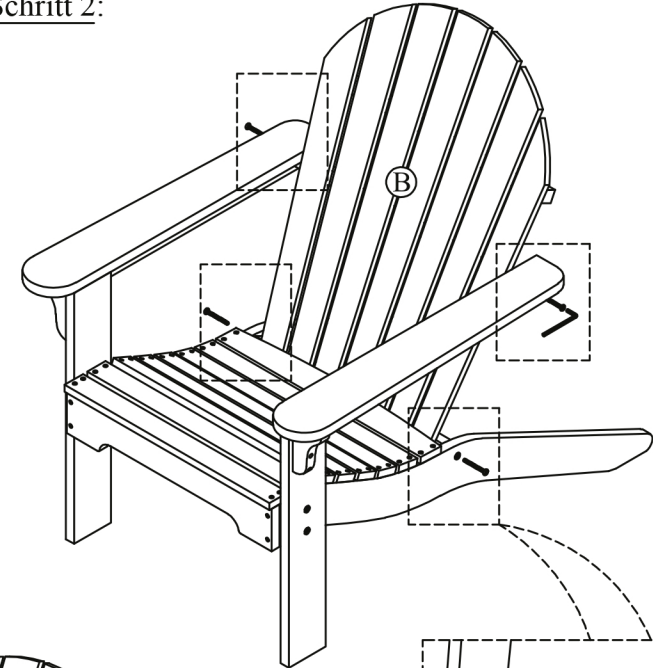

Benötigtes Werkzeug

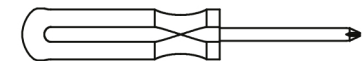

Kreuzschlitz-Schraubendreher (nicht enthalten)