

finori GmbH
Straßäcker 2
D - 96253 Untersiemau

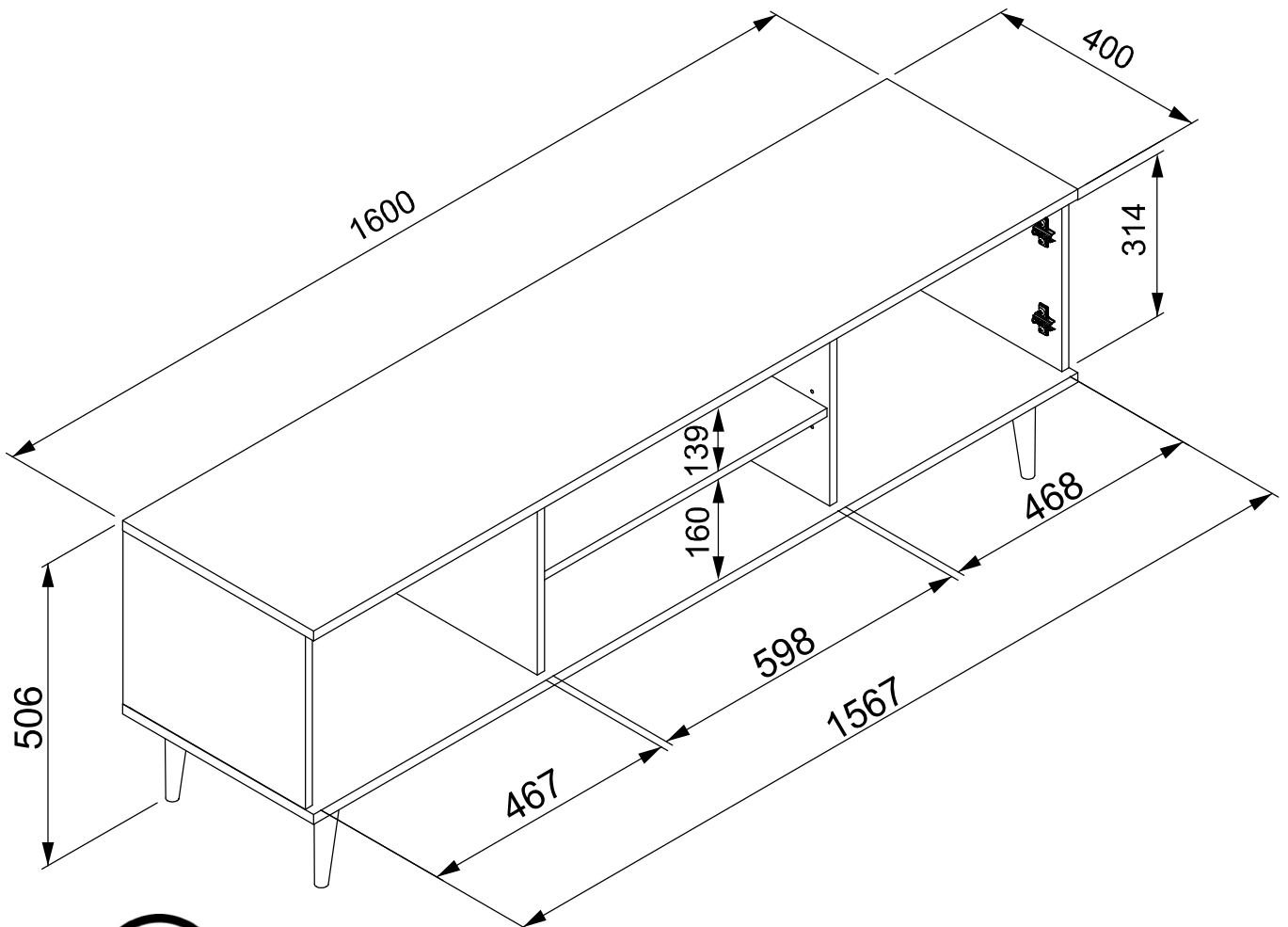



- Ⓓ Befolgen Sie stets die Anleitung des Herstellers!
- ⒸⒹ Please generally follow the manufacturer's instructions!
- ⒻⒼ Suivez toujours les instructions du fabricant!
- ⒹⒻ Volg steeds de handleiding van de producent!
- ⒺⒾ Siga siempre las instrucciones del fabricante!
- ⒹⒶ Stale przestrzegaj instrukcji producenta!

- ⒹⒶ Всегда следуйте инструкции производителя!
- ⒹⒶ Seguire sempre le istruzioni del produttore!
- ⒹⒶ Mindig tartsa be a gyártó utasításait!
- ⒹⒶ Siga sempre as instruções do fabricante!
- ⒹⒶ Vždy dodržujte pokyny výrobce!

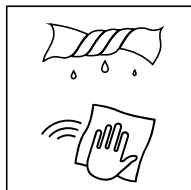

- Ⓓ Verwenden Sie zur Reinigung nur ein feuchtes Tuch!
- ⒸⒹ Please only clean with a damp cloth!
- ⒻⒼ N'utilisez qu'un chiffon humide pour le nettoyage!
- ⒹⒻ Gebruik voor de reiniging enkel een vochtige doek!
- ⒺⒾ Para limpiar utilice sólo un paño húmedo!
- ⒹⒶ Do czyszczenia używaj wilgotnej szmatki!

- ⒹⒶ Для очистки используйте только влажную ткань!
- ⒹⒶ Per la pulizia, utilizzare solo un panno umido!
- ⒹⒶ A tisztításhoz elegendő egy nedves kendő használatát!
- ⒹⒶ Para a limpeza use apenas um pano húmido!
- ⒹⒶ Pro čištění používejte pouze vlhký hadřík!

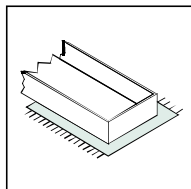

- Ⓓ Bauen Sie das Produkt auf einer Unterlage auf!
- ⒸⒹ Please mount the product on a bottom support!
- ⒻⒼ Montez le produit sur une base!
- ⒹⒻ Monteer het product op een basis!
- ⒺⒾ Monte el producto sobre una base!
- ⒹⒶ Rozkładaj produkt na podkładce!

- ⒹⒶ Собирайте изделие на подстилке!
- ⒹⒶ Montare il prodotto su un supporto!
- ⒹⒶ Az összeszereléskor helyezzen a termék alá megfelelő alátétet!
- ⒹⒶ Monte o produto numa superfície plana!
- ⒹⒶ Výrobek smontujte na pevném podkladu!

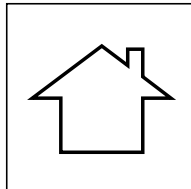

- Ⓓ Verwenden Sie das Produkt nur in Innenräumen!
- ⒸⒹ Please exclusively use the product indoors!
- ⒻⒼ N'utilisez le produit qu'à l'intérieur!
- ⒹⒻ Gebruik het product enkel binnenshuis!
- ⒺⒾ Utilice el producto sólo en interiores!
- ⒹⒶ Używaj produkt tylko w pomieszczeniach wewnętrznych!

- ⒹⒶ Используйте изделие только во внутренних помещениях!
- ⒹⒶ Utilizzare il prodotto solo in ambienti interni!
- ⒹⒶ A termék csak bel terekben használható!
- ⒹⒶ Use o produto apenas no interior!
- ⒹⒶ Používejte výrobek pouze uvnitř!

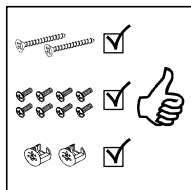

- Ⓓ Legen Sie die Beschläge zusammen und prüfen Sie die Vollständigkeit!
- ⒸⒹ Please join the fittings and verify their completeness!
- ⒻⒼ Pliez les raccords ensemble et vérifiez qu'ils sont complets!
- ⒹⒻ Leg de onderdelen samen en controleer de volledigheid!
- ⒺⒾ Junte los accesorios y compruebe que están todos!
- ⒹⒶ Rozlož poszczególne części i sprawdź kompletność!

- ⒹⒶ Положите фурнитуру в одно место и проверьте комплектность!
- ⒹⒶ Mettere insieme le guarnizioni e verificarne la completezza!
- ⒹⒶ Állítsa össze a sarokvasakat, és ellenőrizze, hogy épek-e!
- ⒹⒶ Coloque os encaixes juntos e verifique se estão completos!
- ⒹⒶ Složte armatury a zkontrolujte úplnost!

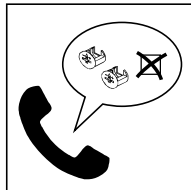

- Ⓓ Bei fehlenden Teilen kontaktieren Sie den Hersteller!
- ⒸⒹ If parts are missing, please turn to the manufacturer!
- ⒻⒼ En cas de pièces manquantes, veuillez contacter le fabricant!
- ⒹⒻ Contacteer de fabrikant als er onderdelen ontbreken!
- ⒺⒾ En el caso de que falten piezas, póngase en contacto con el fabricante!
- ⒹⒶ W razie braku części skontaktuj się z producentem!

- ⒹⒶ При отсутствии каких-либо частей обратитесь к производителю!
- ⒹⒶ In caso di pezzi mancanti, contattare il produttore!
- ⒹⒶ Ha hiányozna valamelyik elem, lépjen kapcsolatba a gyártóval!
- ⒹⒶ Em caso de peças em falta, entre em contato com o fabricante!
- ⒹⒶ Pro chybějící díly kontaktujte výrobce!

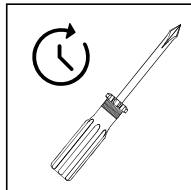

- Ⓓ Ziehen Sie die Schrauben nach einiger Zeit des Gebrauchs erneut fest!
- ⒸⒹ Please re-tighten the screws after having used the product for a while!
- ⒻⒼ Resserrer les vis après un certain temps d'utilisation!
- ⒹⒻ Draai de schroeven na een zekere gebruikstijd opnieuw vast!
- ⒺⒾ Asegure de nuevo los tornillos tras usarlo durante un tiempo!
- ⒹⒶ Po pewnym czasie użytkowania ponownie dokręć śruby!

- ⒹⒶ Спустя некоторое время использования подкрутите гайки!
- ⒹⒶ Stringere nuovamente le viti dopo un certo periodo di utilizzo!
- ⒹⒶ A használat során némi idő elteltével húzza meg újra a csavarokat!
- ⒹⒶ Reaperte os parafusos após algum tempo de uso!
- ⒹⒶ Po určité době používání šrouby znovu utáhněte!

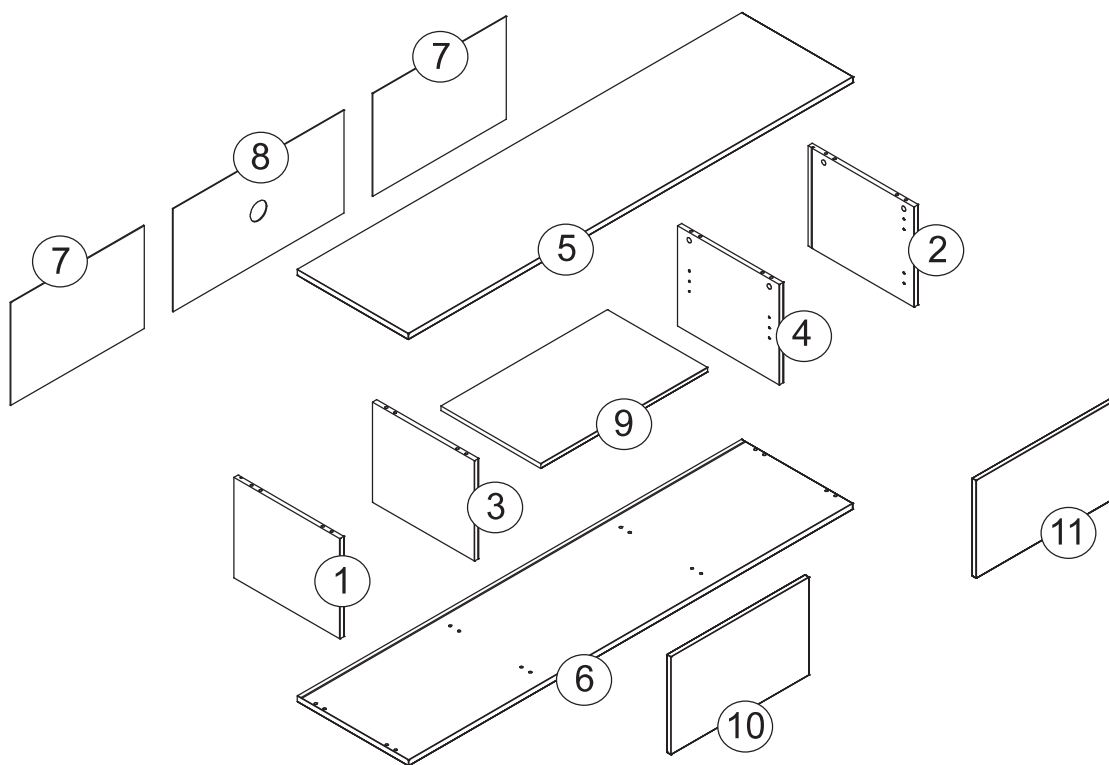
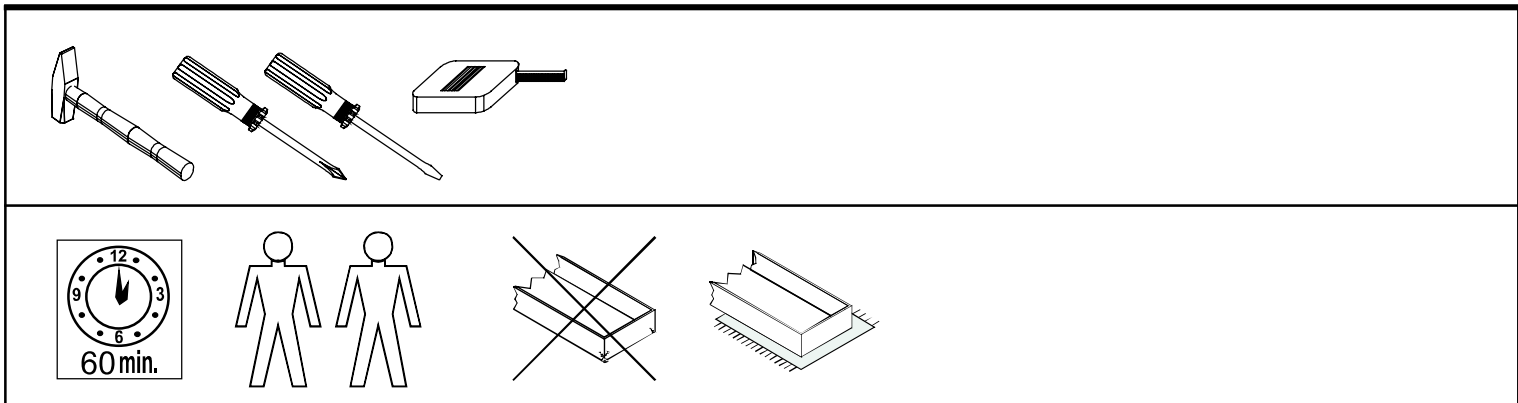

Dimensions / Abmessung in mm/		
①	1 x	314 x 382 x 16
②	1 x	314 x 382 x 16
③	1 x	314 x 364 x 16
④	1 x	314 x 364 x 16
⑤	1 x	1600 x 400 x 18
⑥	1 x	1600 x 400 x 18
⑦	2 x	480 x 324 x 2,5
⑧	1 x	613 x 324 x 2,5
⑨	1 x	598 x 359 x 16
⑩	1 x	496 x 308 x 16
⑪	1 x	496 x 308 x 16

BOX 1	1, 2, 3, 4, 5, 6, 2x7, 8, 9, 10, 11
--------------	-------------------------------------

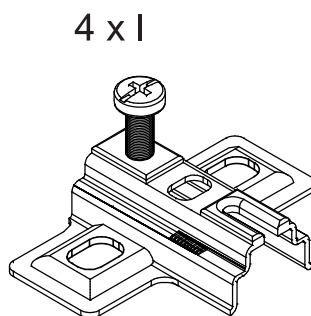
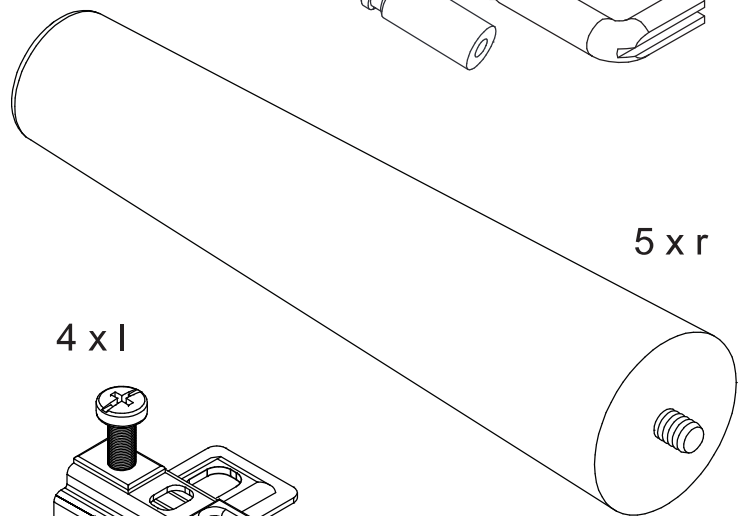
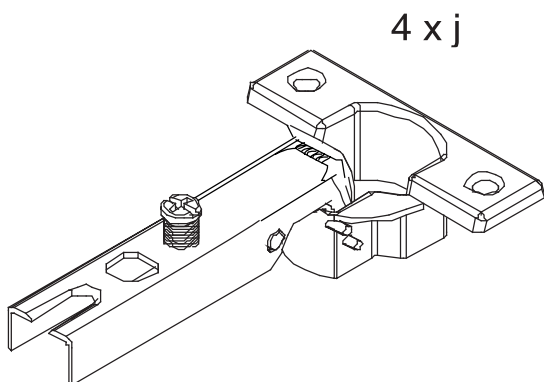
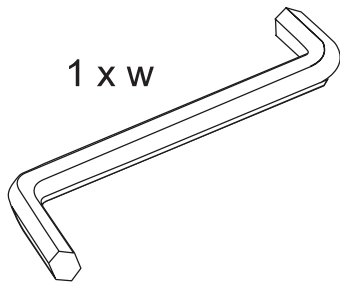
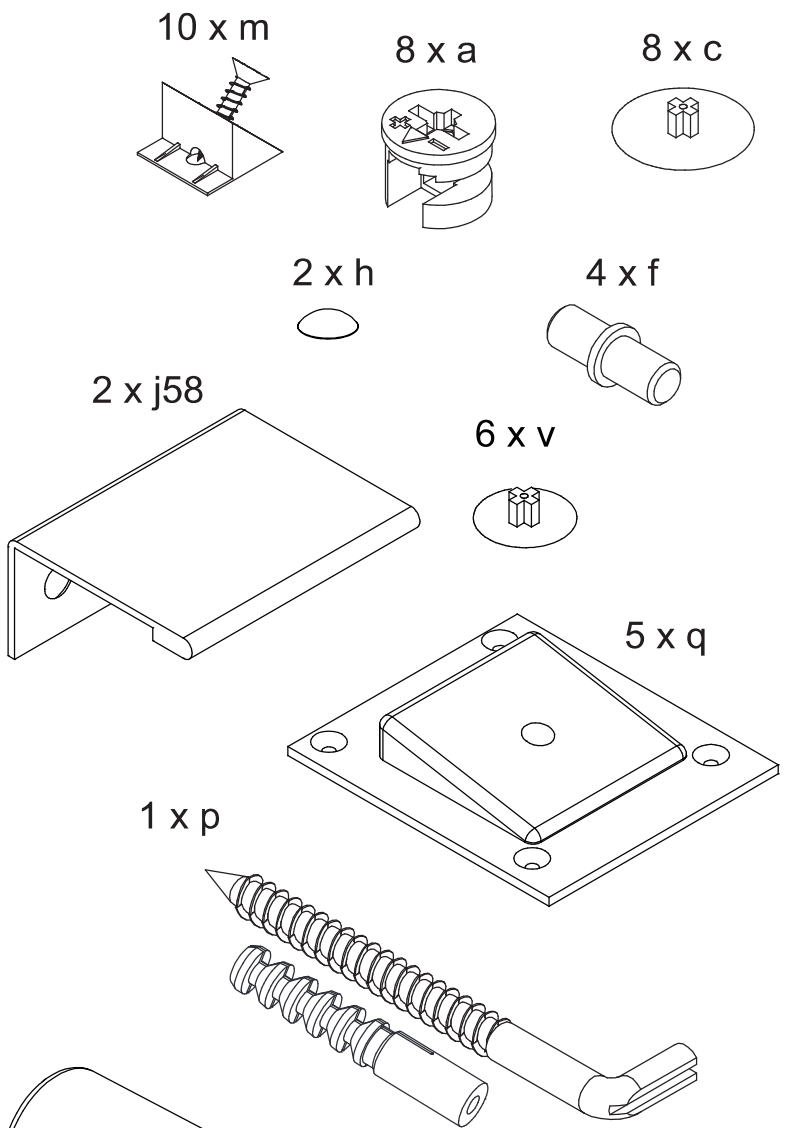
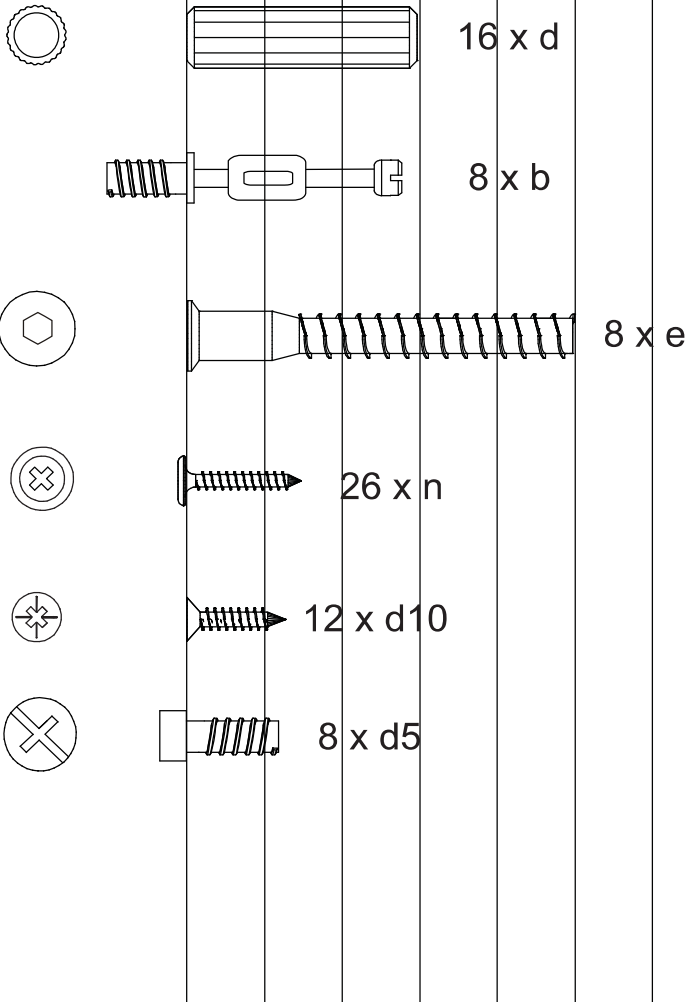
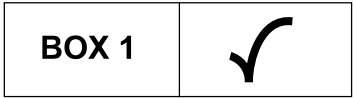

A

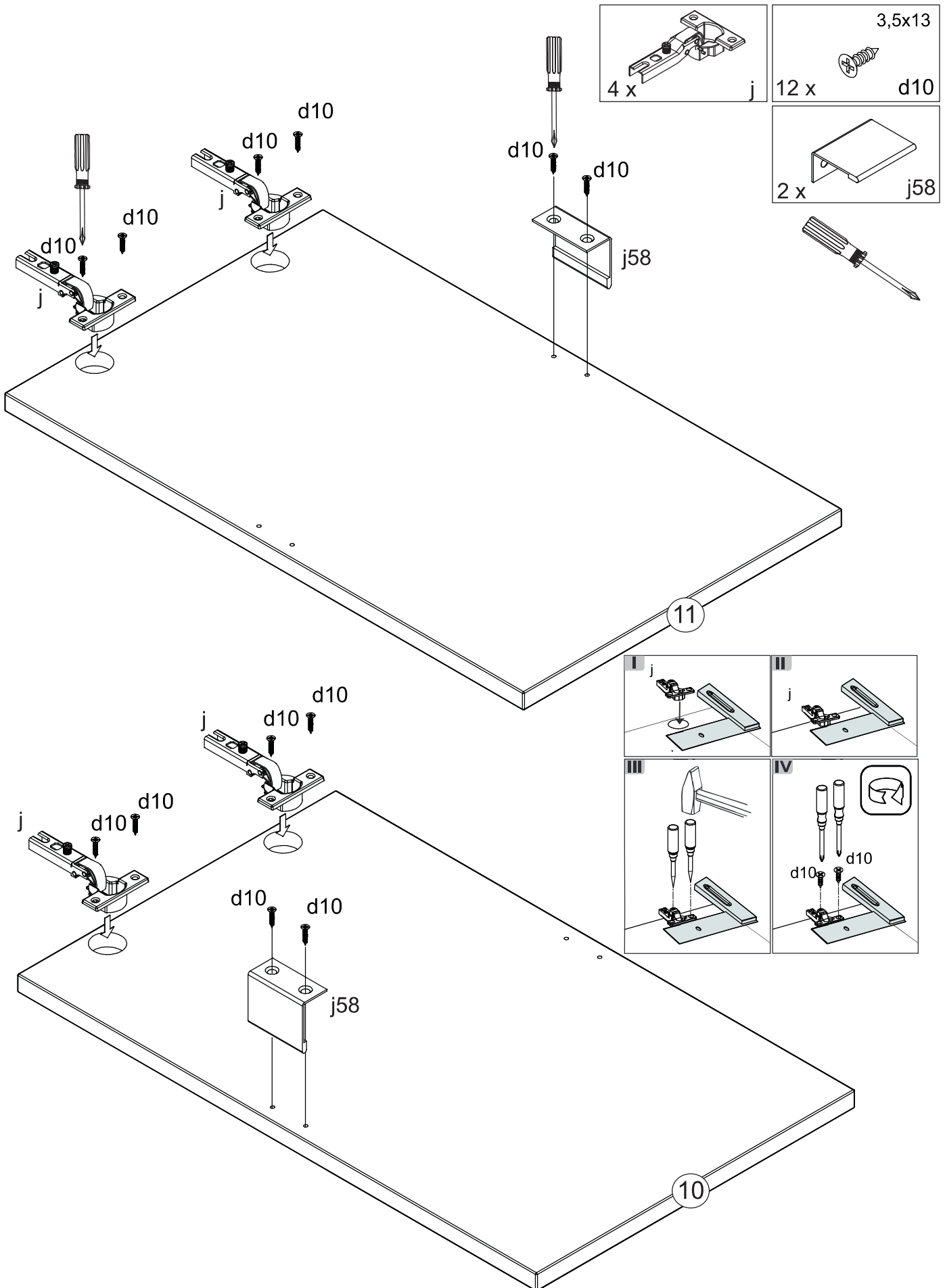

B

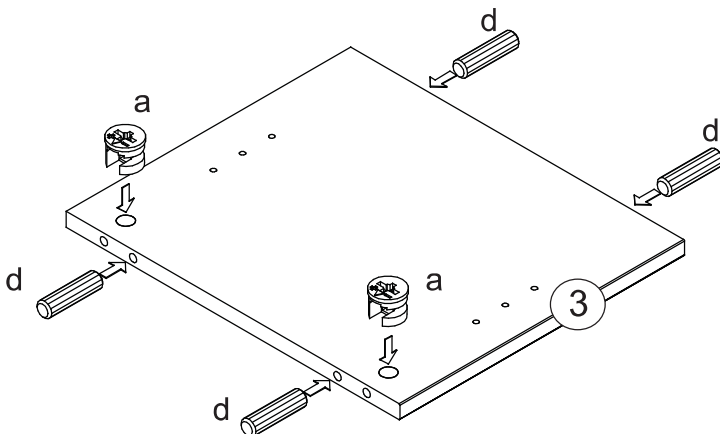
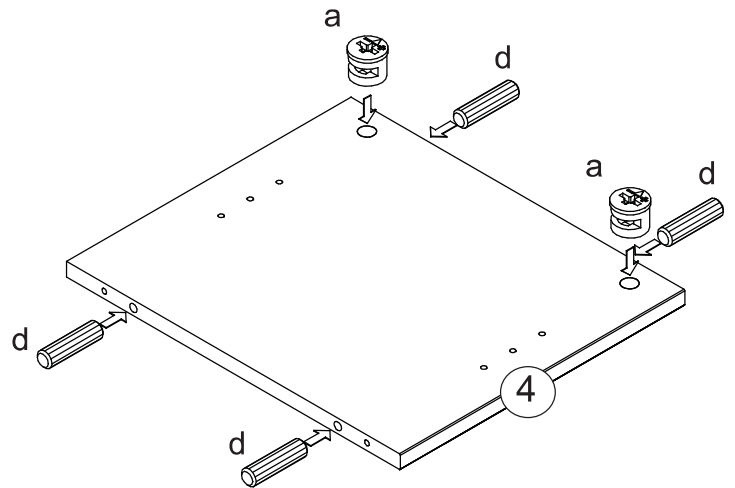
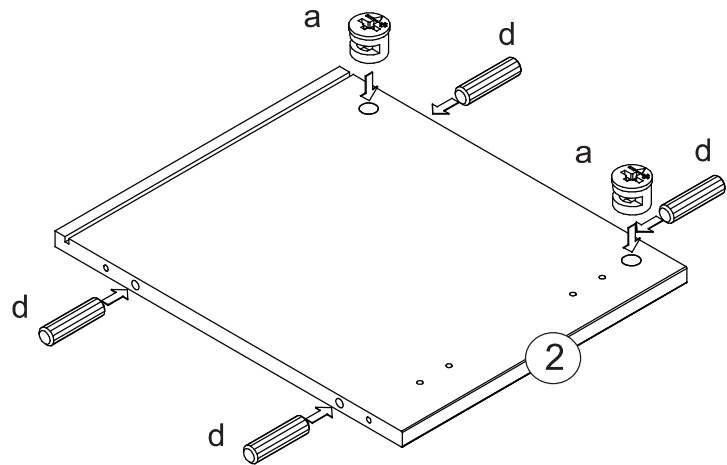
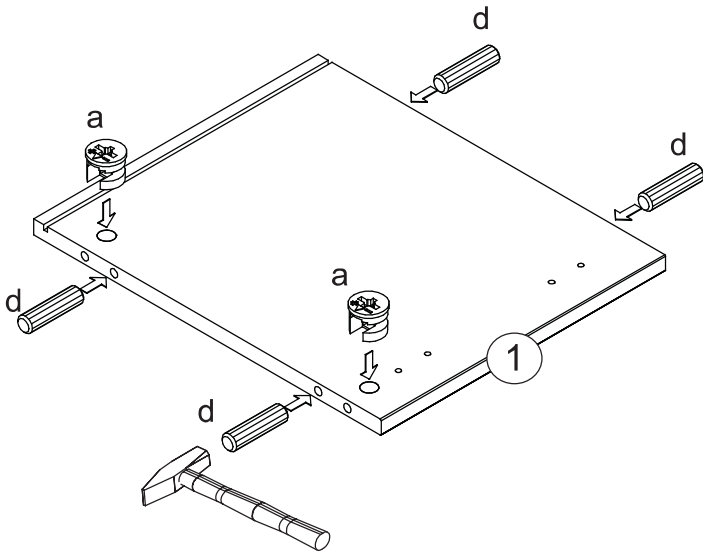
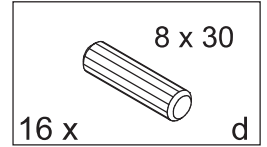
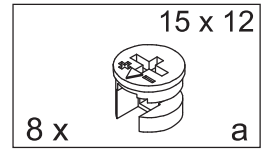
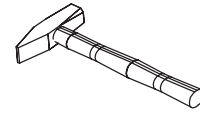
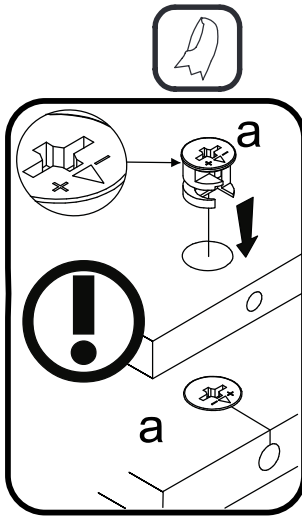

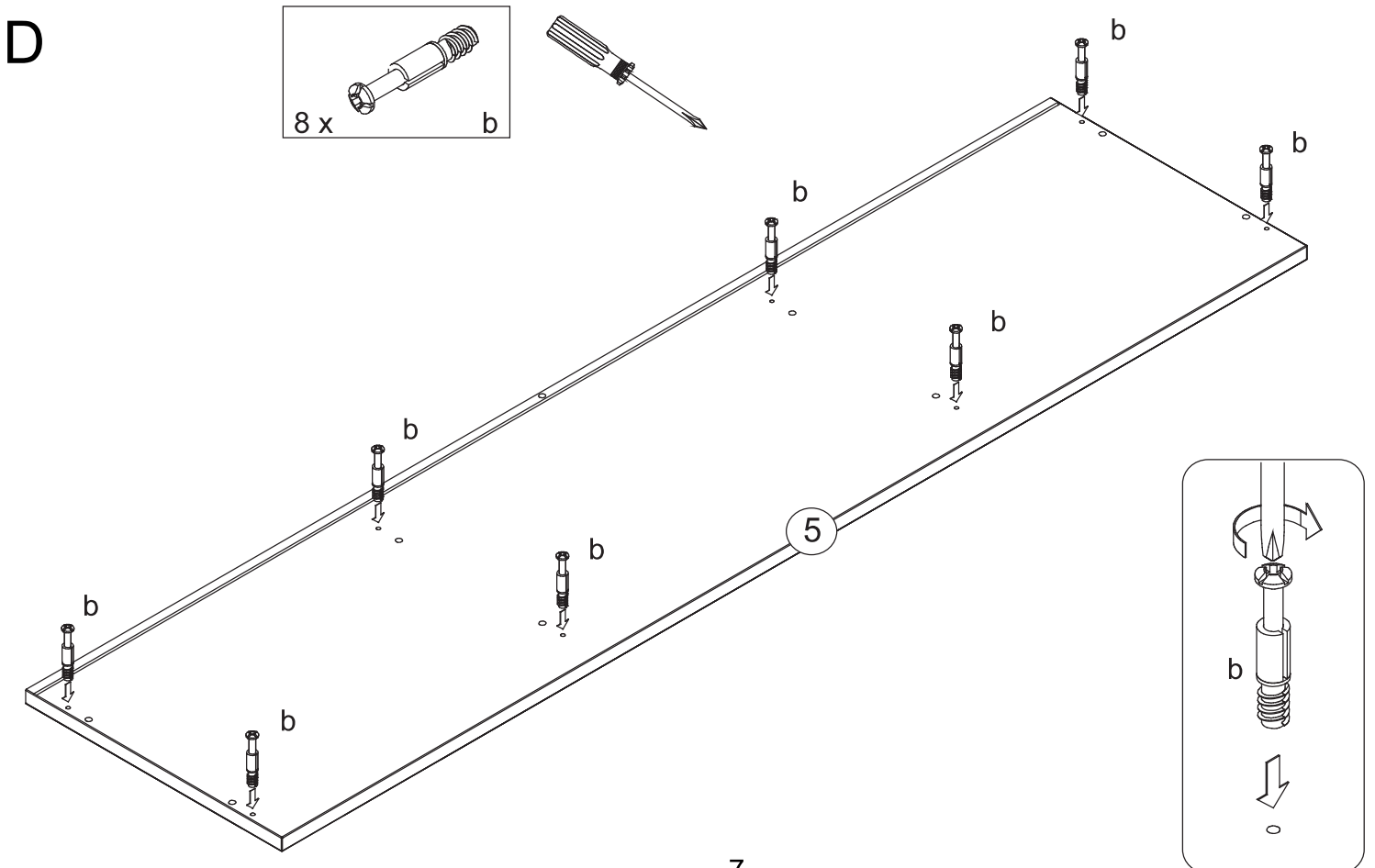
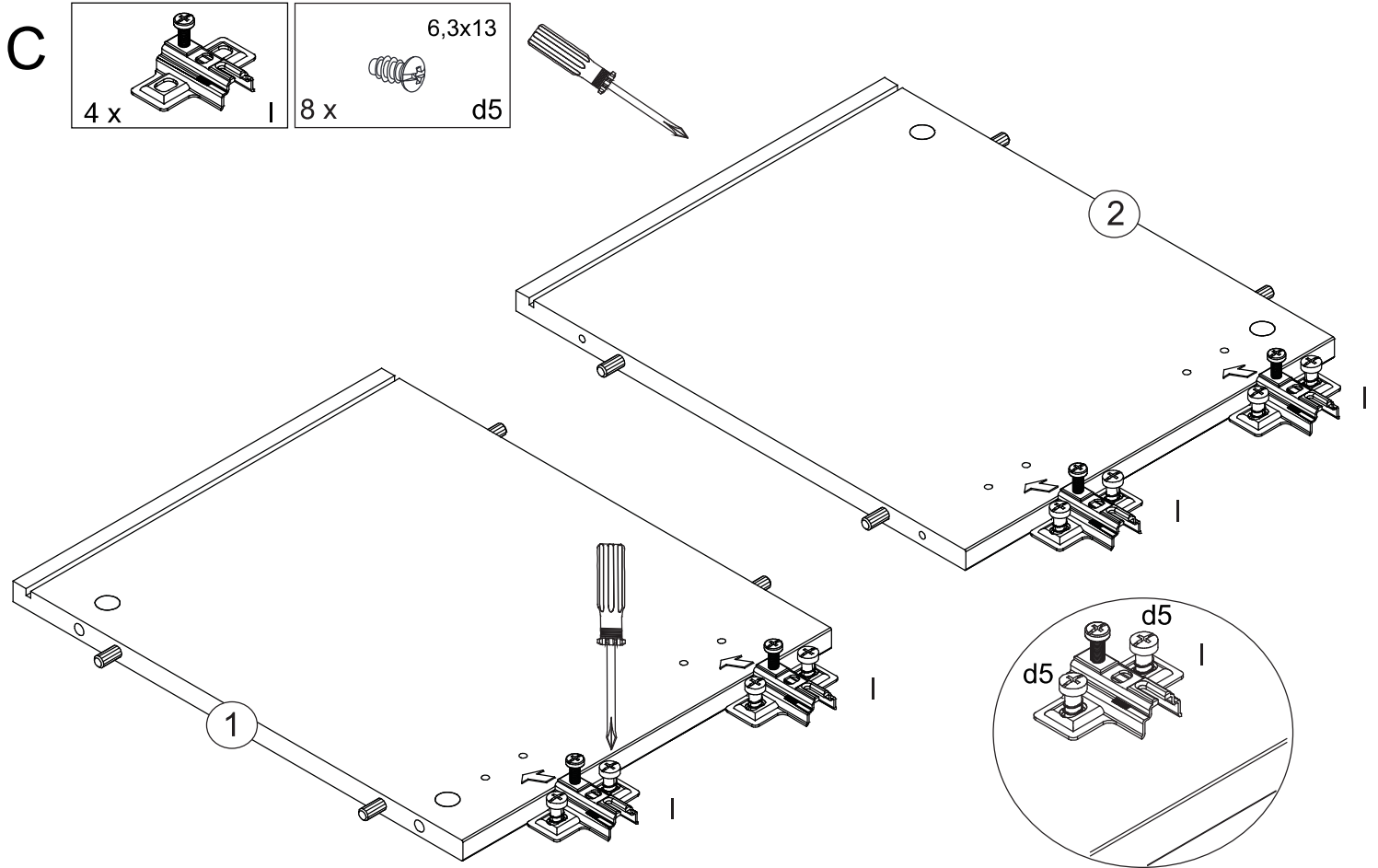

E

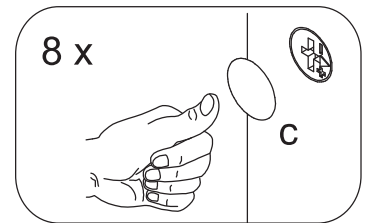
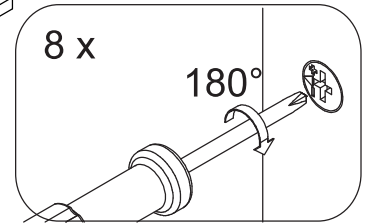
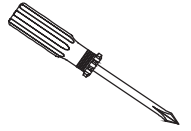
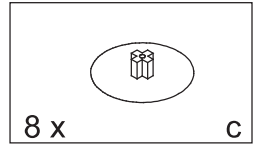
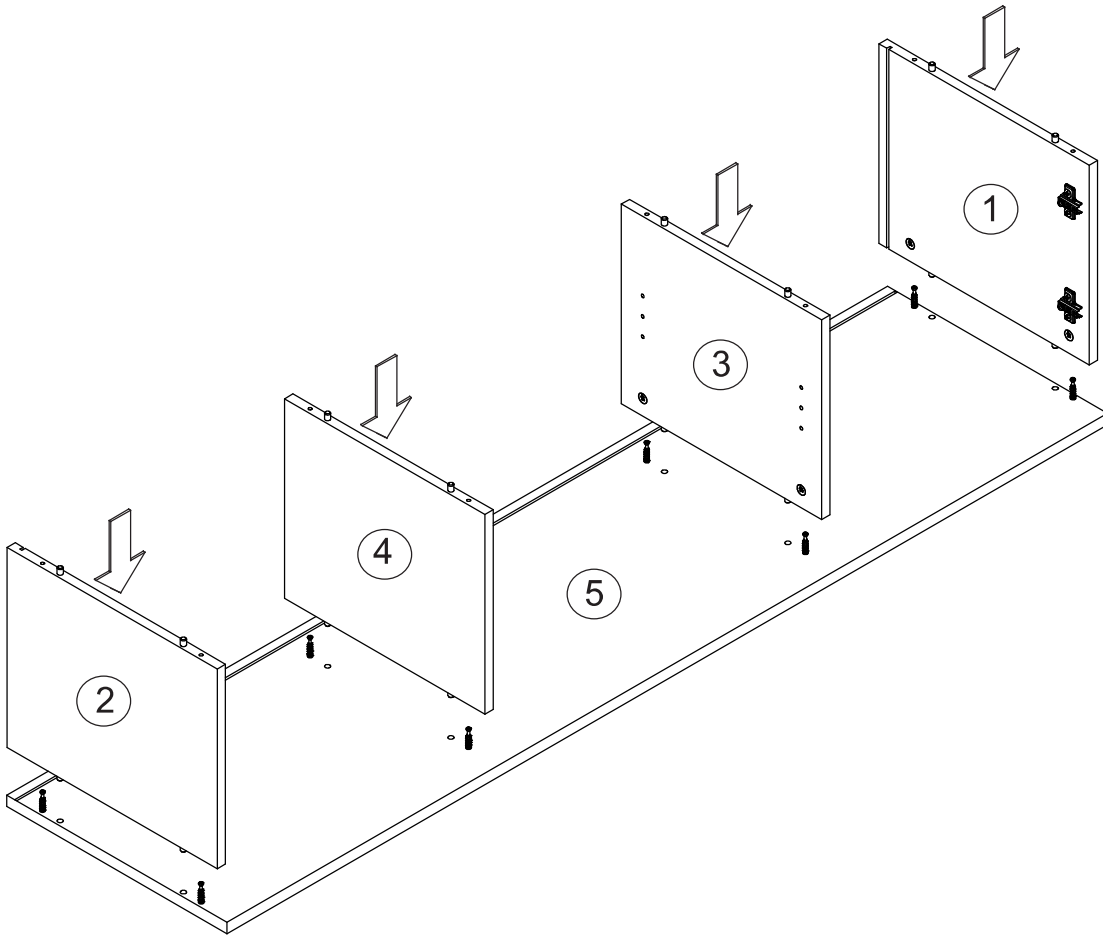

F

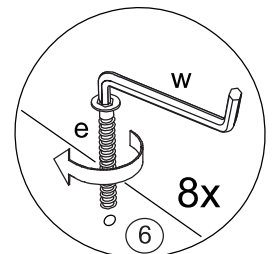
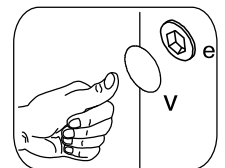
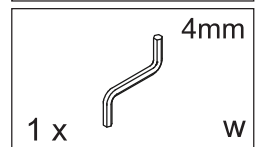
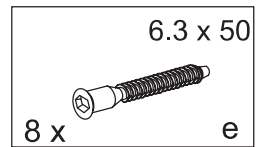
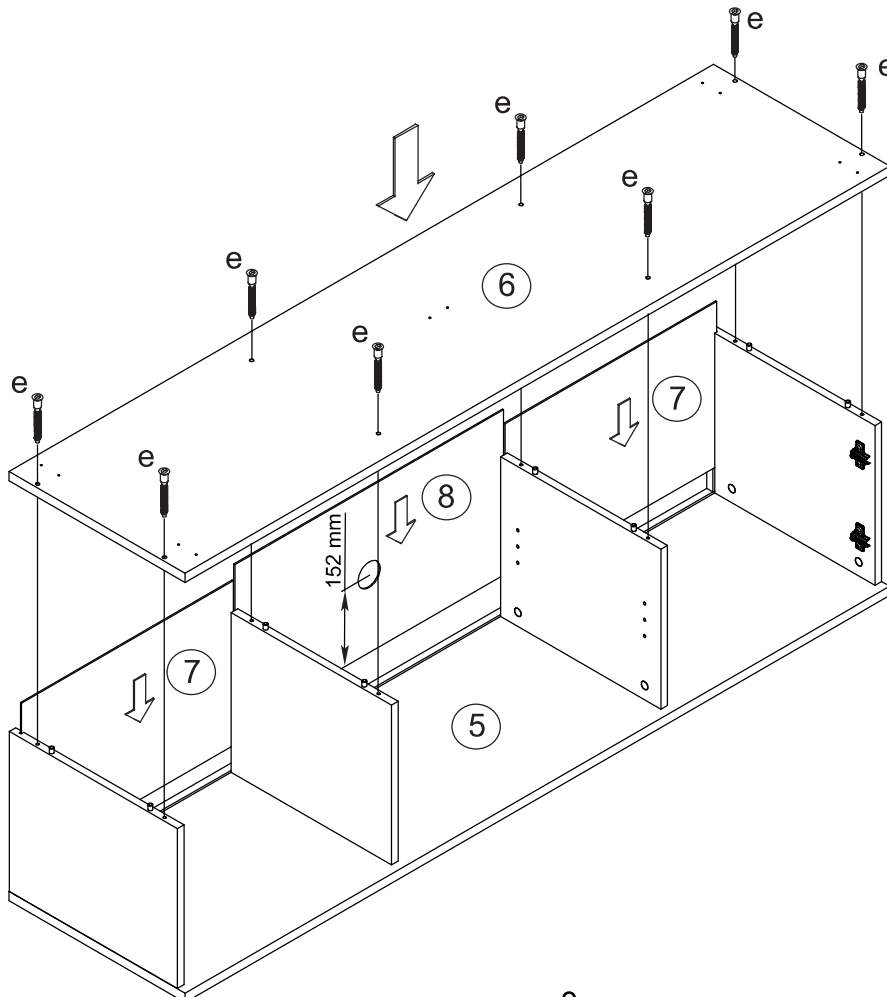

G

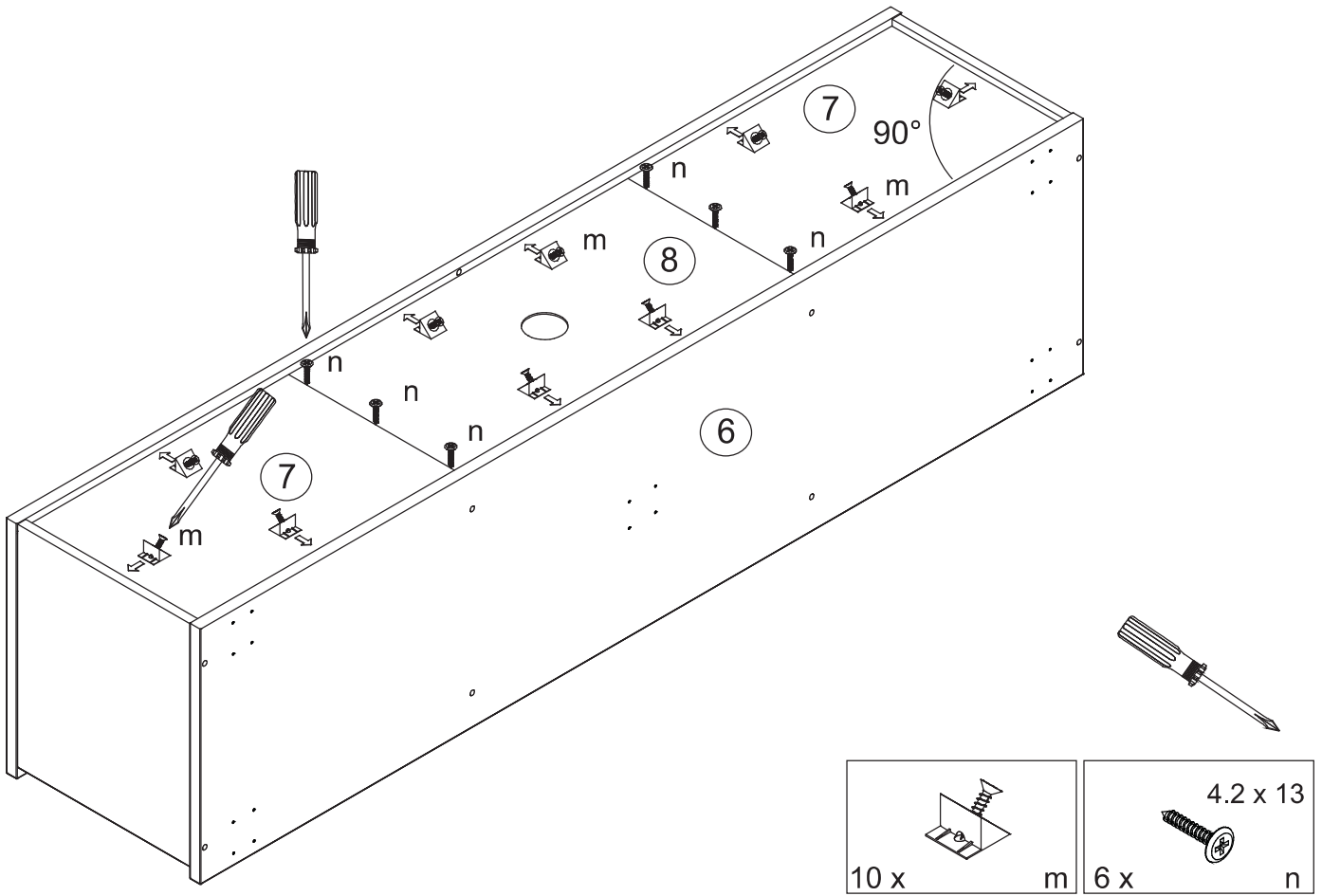

H

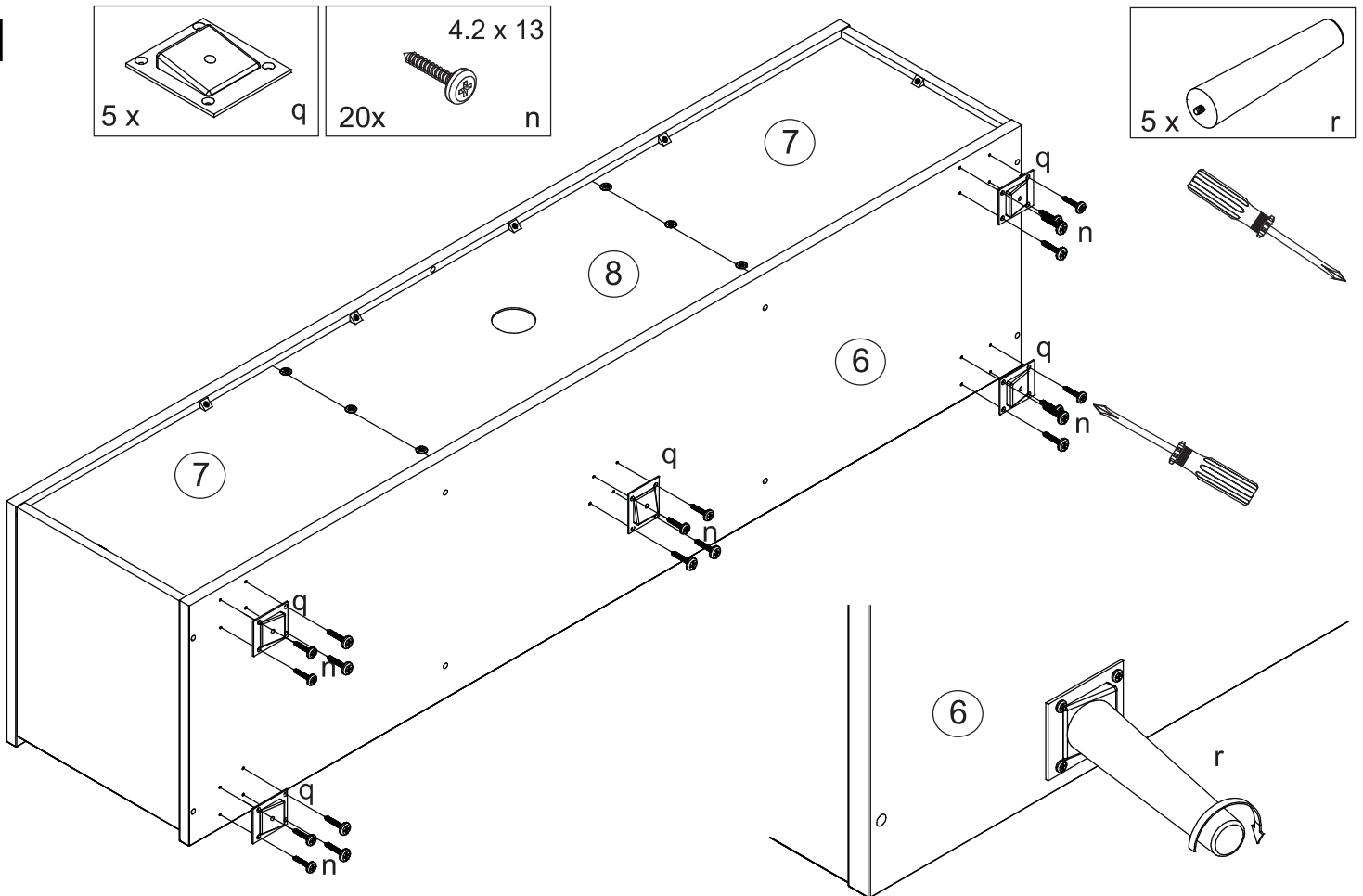

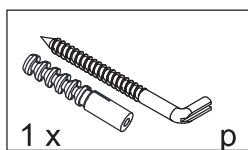

Le meuble doit être fixé au mur!
 Das Möbel muss an der Wand befestigt werden!
 This unit must be secured to a wall using suitable fixing (not supplied)!



*Attention!
 Veuillez-vous informer sur le type de cheville et vis approprié à la nature de votre mur.
 *Achtung!
 informieren Sie sich vor der Wandmontage über das geeignete Montagematerial für ihre Wand!
 *Caution!
 Please inform yourself about mounting material suitable for your wall before mounting.

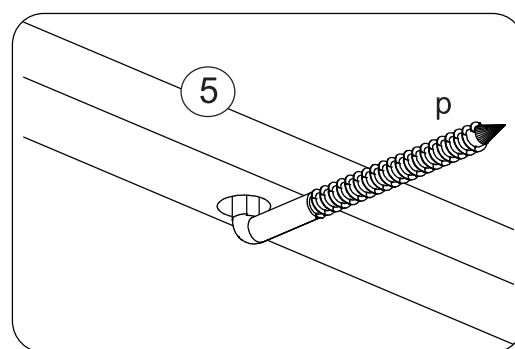
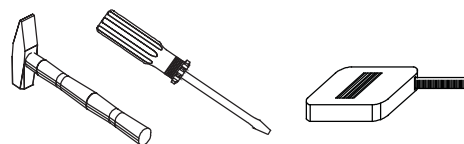
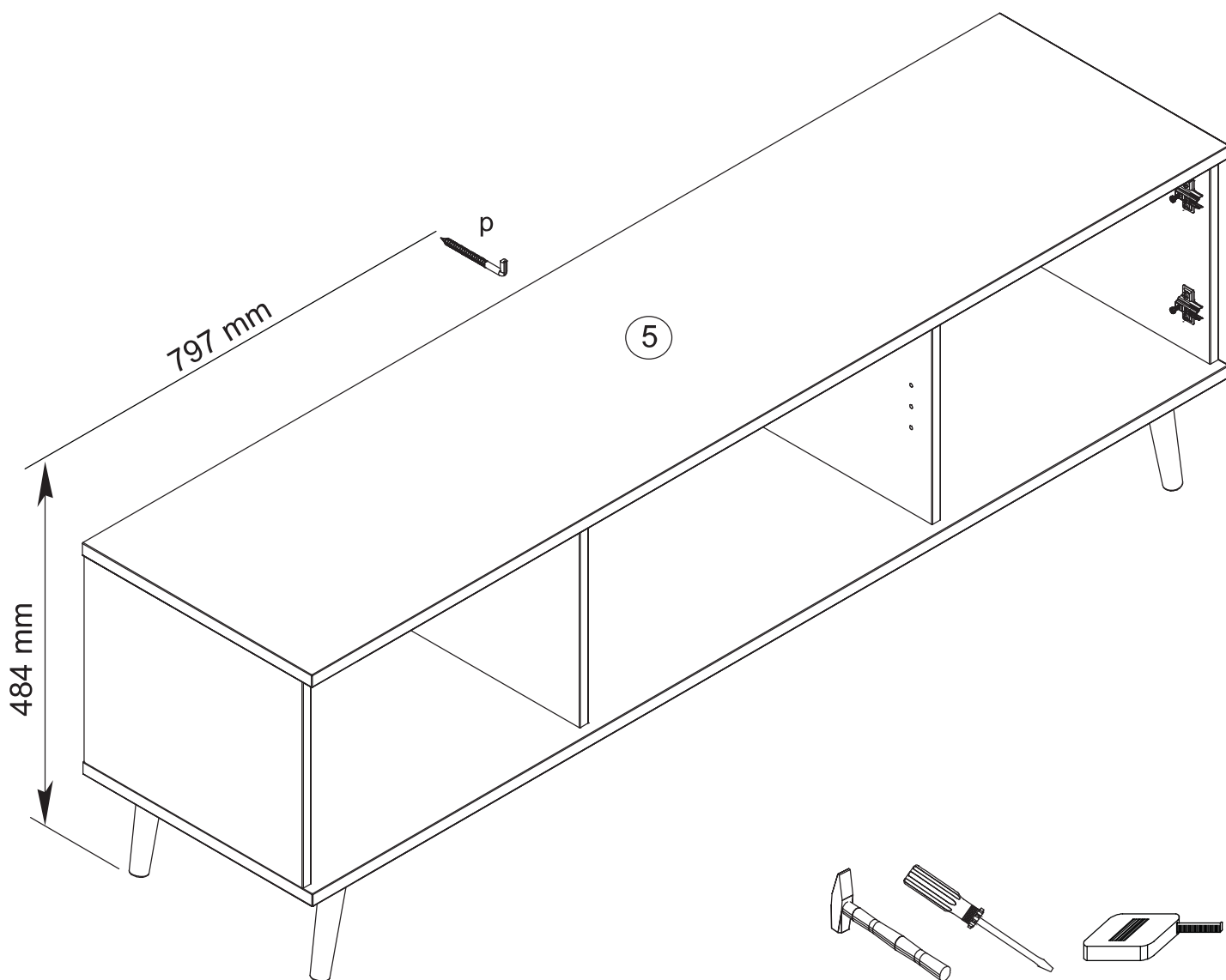

J

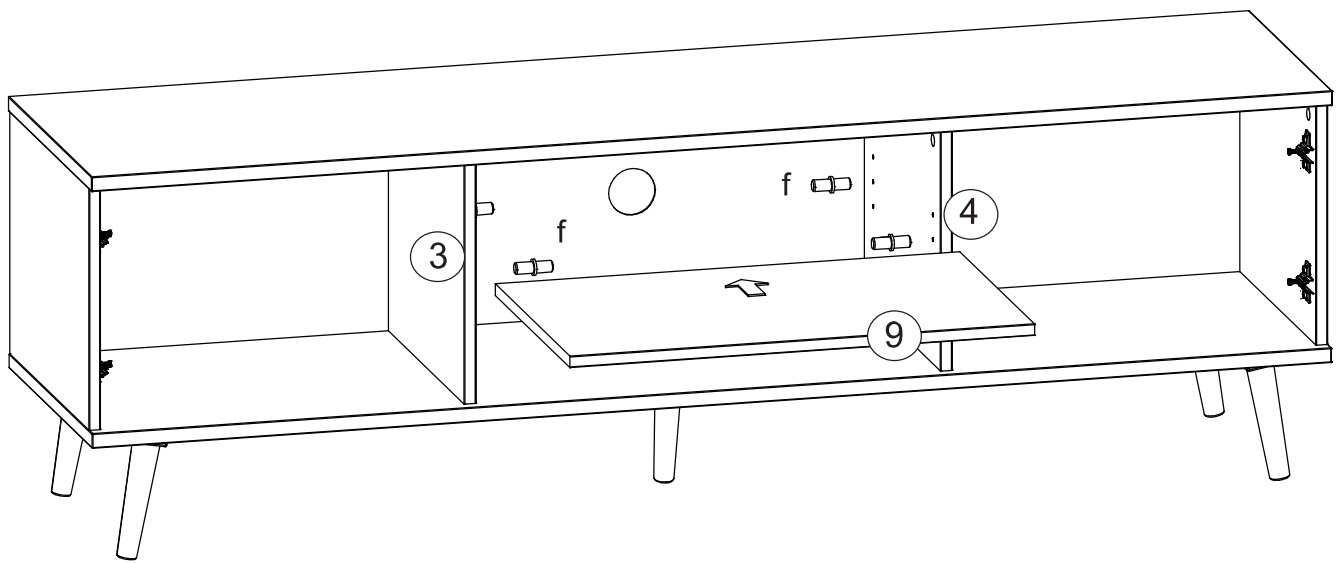
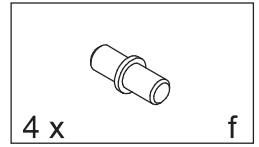

K

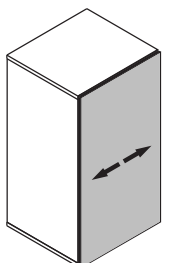
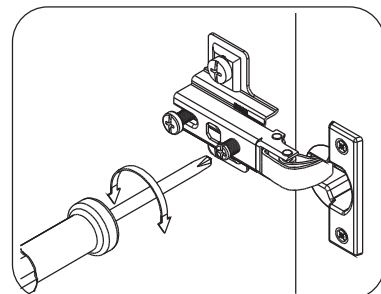
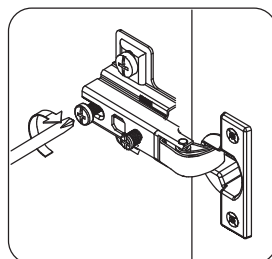
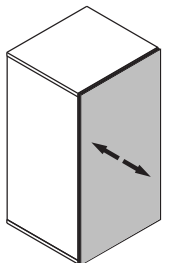
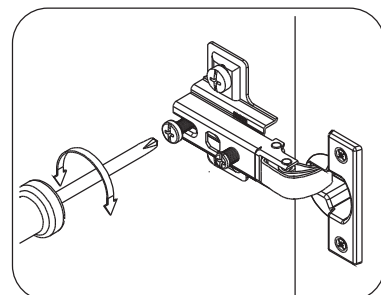
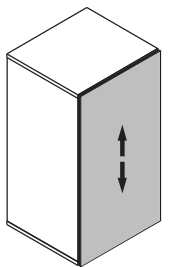
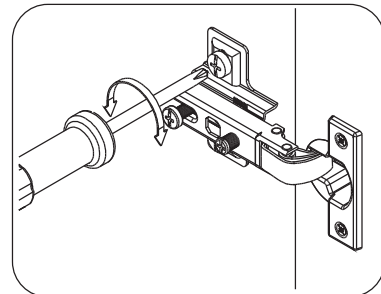
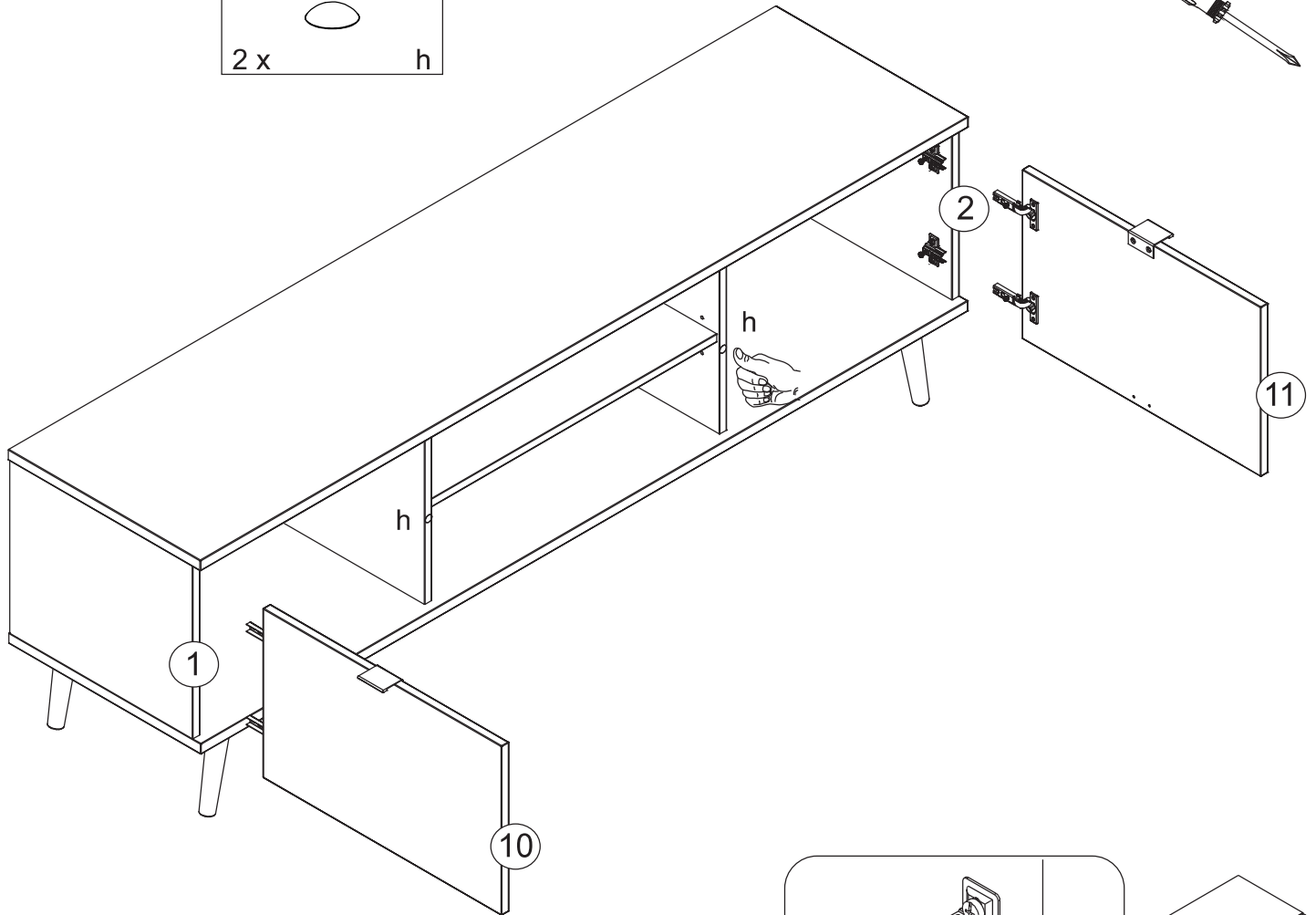
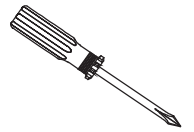
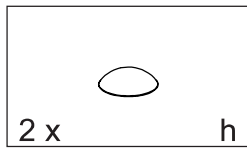



- Ⓓ Das Möbel muss an der Wand befestigt werden!
- ⒸⓅ Please ensure to mount the furniture to the wall!
- ⒻⓃ Les meubles doivent être fixés au mur!
- ⓃⒻ Het meubel moet aan de wand worden vastgemaakt!
- ⒺⓈ El mueble se tiene que fijar a la pared!
- ⒻⒻ Mebel należy przymocować do ściany!



- Ⓓ Informieren Sie sich vor der Wandmontage über das geeignete Montagematerial!
- ⒸⓅ Please get informed on suitable assembly materials before commencing the wall-mounting!
- ⒻⓃ Renseignez-vous sur le matériel de montage approprié avant le montage mural!
- ⓃⒻ Informeer u voor de wandmontage over het geschikte montagematerieel!
- ⒺⓈ Infórmese antes del montaje en la pared del material apropiado de montaje!
- ⒻⒻ Przed montażem na ścianie upewnij się, jaki jest potrzebny właściwy materiał montażowy!



- Ⓓ Beschafen Sie sich das angemessene Material zur Wandbefestigung!
- ⒸⓅ Please obtain suitable wall-mounting materials!
- ⒻⓃ Procurez-vous le matériel approprié pour le montage mural!
- ⓃⒻ Verschaf u het adequate materieel voor de wandbevestiging!
- ⒺⓈ Procúrese el material adecuado para la fijación a la pared!
- ⒻⒻ Zakup odpowiedni materiał do przymocowania na ścianie!



- Ⓓ Lassen Sie die Wandbefestigung von einer fachkundigen Person vornehmen!
- ⒸⓅ Ensure all wall-mounting is carried out by competent personnel!
- ⒻⓃ Faites effectuer le montage mural par une personne compétente!
- ⓃⒻ Laat de wandbevestiging door een professional uitvoeren!
- ⒺⓈ Deje que la fijación a la pared la haga un profesional!
- ⒻⒻ Zleć przymocowanie do ściany odpowiednio doświadczonej osobie!

- ⒲Ⓐ Мебель должна крепиться к стене!
- ⒲Ⓓ Il mobile deve essere fissato alla parete!
- ⒲Ⓐ A bútor a falon rögzítendő!
- ⒲Ⓓ O móvel tem que ser fixado na parede!
- ⒲Ⓓ Nábytek musí být připevněn ke stěně!

- ⒲Ⓐ Перед тем, как крепить мебель к стене, получите информацию о подходящем крепежном материале!
- ⒲Ⓓ Prima del fissaggio alla parete, informarsi sul materiale di montaggio adatto!
- ⒲Ⓐ A falra szerelés előtt tájékozódjon, hogy ehhez milyen szerelőanyagok szükségesek!
- ⒲Ⓓ Antes da montagem na parede, informe-se sobre o material de montagem adequado!
- ⒲Ⓓ Informujte se o vhodném montážním materiálu před montáží na stěnu!

- ⒲Ⓐ Приобретите соответствующий материал для крепления к стене!
- ⒲Ⓓ Procurarsi il materiale opportuno per il fissaggio alla parete!
- ⒲Ⓐ Szerezze be a falra szereléshez szükséges, megfelelő anyagokat!
- ⒲Ⓓ Obtenha o material adequado para a montagem na parede!
- ⒲Ⓓ Opatřte si vhodný materiál pro montáž na stěnu!

- ⒲Ⓐ Поручите выполнение работ по креплению к стене специалисту!
- ⒲Ⓓ Far effettuare il fissaggio alla parete ad un esperto!
- ⒲Ⓐ A bútor falra rögzítését végeztesse ehhez értő személlyel!
- ⒲Ⓓ A montagem na parede deve ser executada por uma pessoa competente!
- ⒲Ⓓ Montáž na stěnu nechte provést odborně způsobilou osobou!

