

# Installationsanleitung Installation Instruction Instruction d'installation

## N620P224444

## N620P224445

DE: Unser Produkt wird Ihnen in 2 Paketen geliefert. Die Lieferzeiten dieser 2 Pakete können abweichen, bitte haben Sie etwas Geduld und vielen Dank für Ihr Verständnis.

UK: Our product will be delivered to you in 2 packages. The delivery times of these 2 packages may differ, please be patient and thank you for your understanding.

FR: Notre produit vous sera livré en 2 colis. Les délais de livraison de ces 2 colis peuvent différer, soyez patient et merci pour votre compréhension.



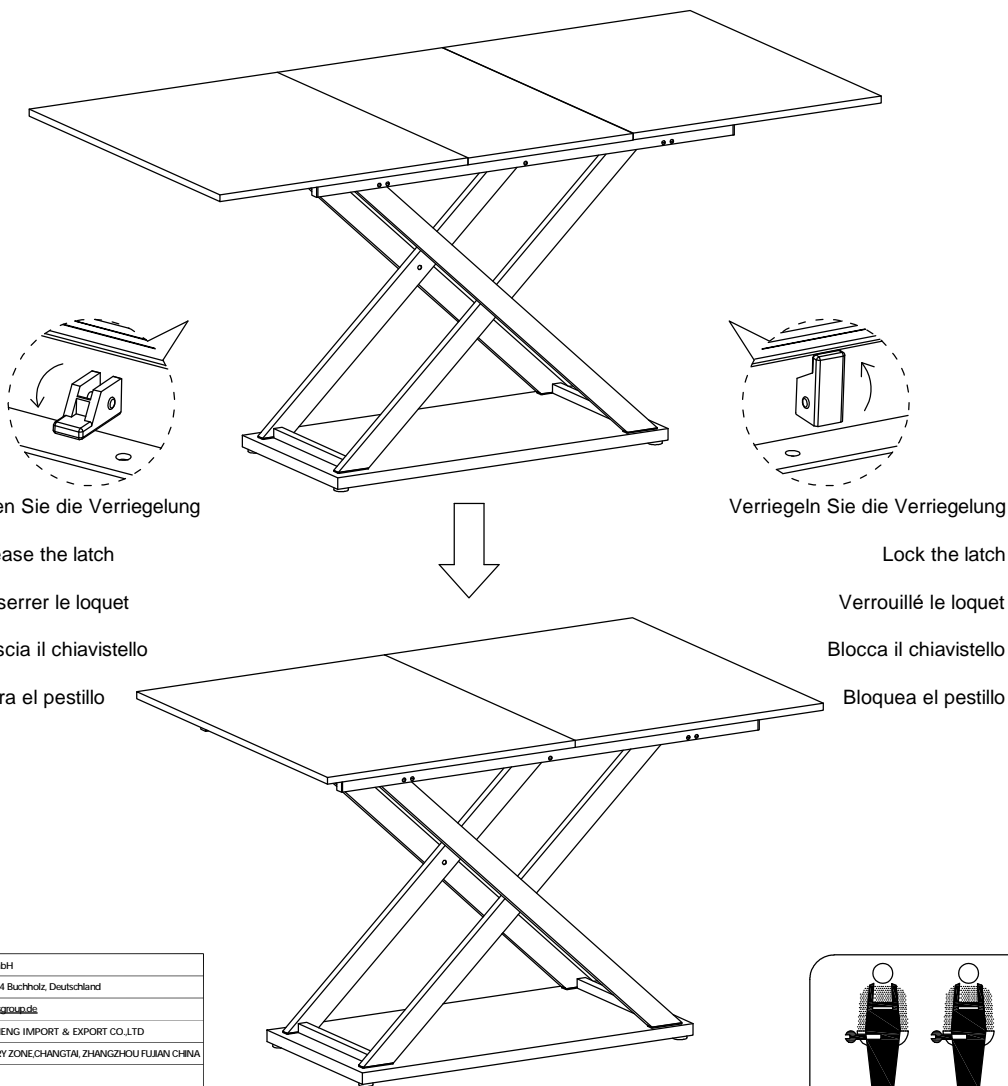

IT: Il nostro prodotto verrà consegnato in 2 pacchi. I tempi di consegna di questi 2 pacchi possono variare; vi preghiamo di avere un po' di pazienza e vi ringraziamo per la vostra comprensione.

ES: Nuestro producto se entregará en 2 paquetes. Los tiempos de entrega de estos 2 paquetes pueden variar; por favor, tenga un poco de paciencia y gracias por su comprensión.

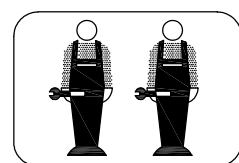

Importeur	Decobus Handel GmbH
Adresse	Innungsstraße 9, 21244 Buchholz, Deutschland
URL	<a href="https://www.decobusgroup.de">https://www.decobusgroup.de</a>
Hersteller	ZHANGZHOU YUCHENG IMPORT & EXPORT CO.,LTD
Adresse	GUANSHAN INDUSTRY ZONE, CHANGTAI, ZHANGZHOU FUJIAN CHINA
Email/URL	<a href="mailto:Elvis@tjpsgg.com.cn">Elvis@tjpsgg.com.cn</a>
EC REP	Decobus Handel GmbH Innungsstraße 9, 21244 Buchholz, Deutschland <a href="https://www.decobusgroup.de">https://www.decobusgroup.de</a>



 φ19x3mm	 φ18x1.8mm
 ×4pcs	 ×8pcs

DE: Bitte beachten Sie, dass die Formen der Schrauben D und E ähnlich sind. Bitte installieren Sie entsprechend der Anleitung und unterscheiden Sie sie!

UK: Please note that the shapes of screws D and E are similar. Please install according to the instructions and distinguish them!

FR: Notez que les vis D et E ont des formes similaires. Veuillez les installer en suivant les instructions pour les séparer!

IT: Si prega di notare che le forme delle viti D, E sono simili. Si prega di installarle seguendo le istruzioni e di distinguerle!

ES: Por favor, tenga en cuenta que las formas de los tornillos D, E son similares. Por favor, instálelos de acuerdo con las instrucciones y distíngalos.

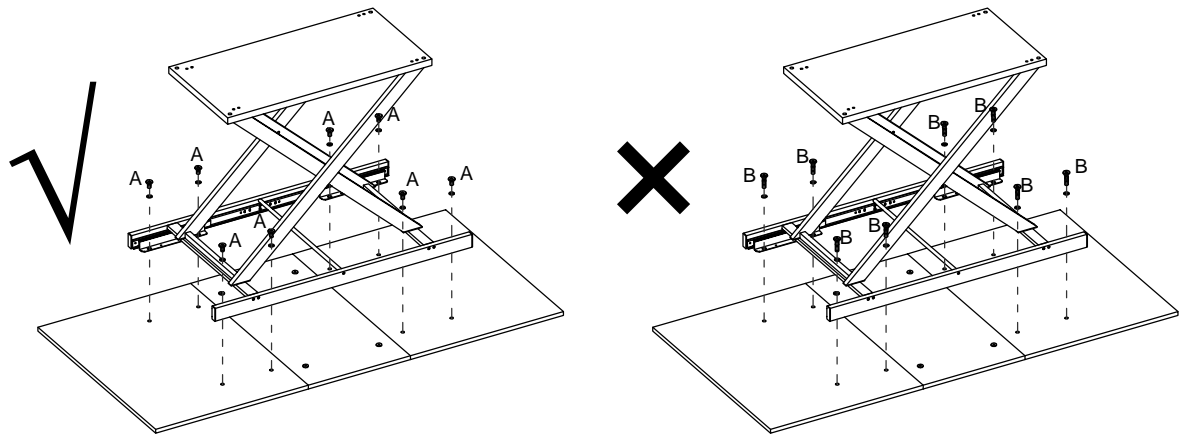

(DE):

Bitte beachten Sie, dass dieses Produkt mehrere Schrauben enthält. Beim Verbinden der Tischplatte und der Tischbeine verwenden Sie bitte unbedingt die kürzesten Schrauben vom Typ A. Die Verwendung falscher Schrauben kann die Tischplatte beschädigen!

(UK):

Please note that this product contains multiple screws. When connecting the desktop and the legs, please be sure to use the shortest screws, type A. Using the wrong screws may damage the desktop!

(FR):

Veillez noter que ce produit contient plusieurs vis. Lors de la connexion du plateau et des pieds, veuillez utiliser absolument les vis les plus courtes, de type A. L'utilisation de vis incorrectes peut endommager le plateau !

(IT):

Si prega di notare che questo prodotto contiene diverse viti. Quando si collegano il piano e le gambe, è assolutamente necessario utilizzare le viti più corte, di tipo A. L'uso di viti sbagliate può danneggiare il piano!

(ES):

Tenga en cuenta que este producto contiene varios tornillos. Al conectar el escritorio y las patas, asegúrese de utilizar los tornillos más cortos, tipo A. El uso de tornillos incorrectos puede dañar el escritorio.

DE:Vor dem Einbau die Schrauben in die Löcher stecken und festziehen, aber nicht bis 100%, 70% bis 80% anziehen reicht aus. Schließlich, nachdem alle Schrauben installiert sind, ziehen Sie alle Schrauben auf 100%.Wenn Sie auf diese Probleme stoßen, wie z. B. Fehlausrichtung der Löcher oder Unfähigkeit, bestimmte Teile zu installieren, überprüfen Sie bitte, ob die Schrauben korrekt verwendet werden und passen Sie die Dichtigkeit der Schrauben an.

UK:Before installation, insert the screws into the holes and tighten them, but do not tighten them to 100%, 70% to 80% is sufficient. Finally, after all screws are installed, tighten all screws to 100%.If you encounter these issues, such as if the holes cannot be aligned or some parts cannot be installed, please check if the screws are used correctly and adjust the tightness of the screws.



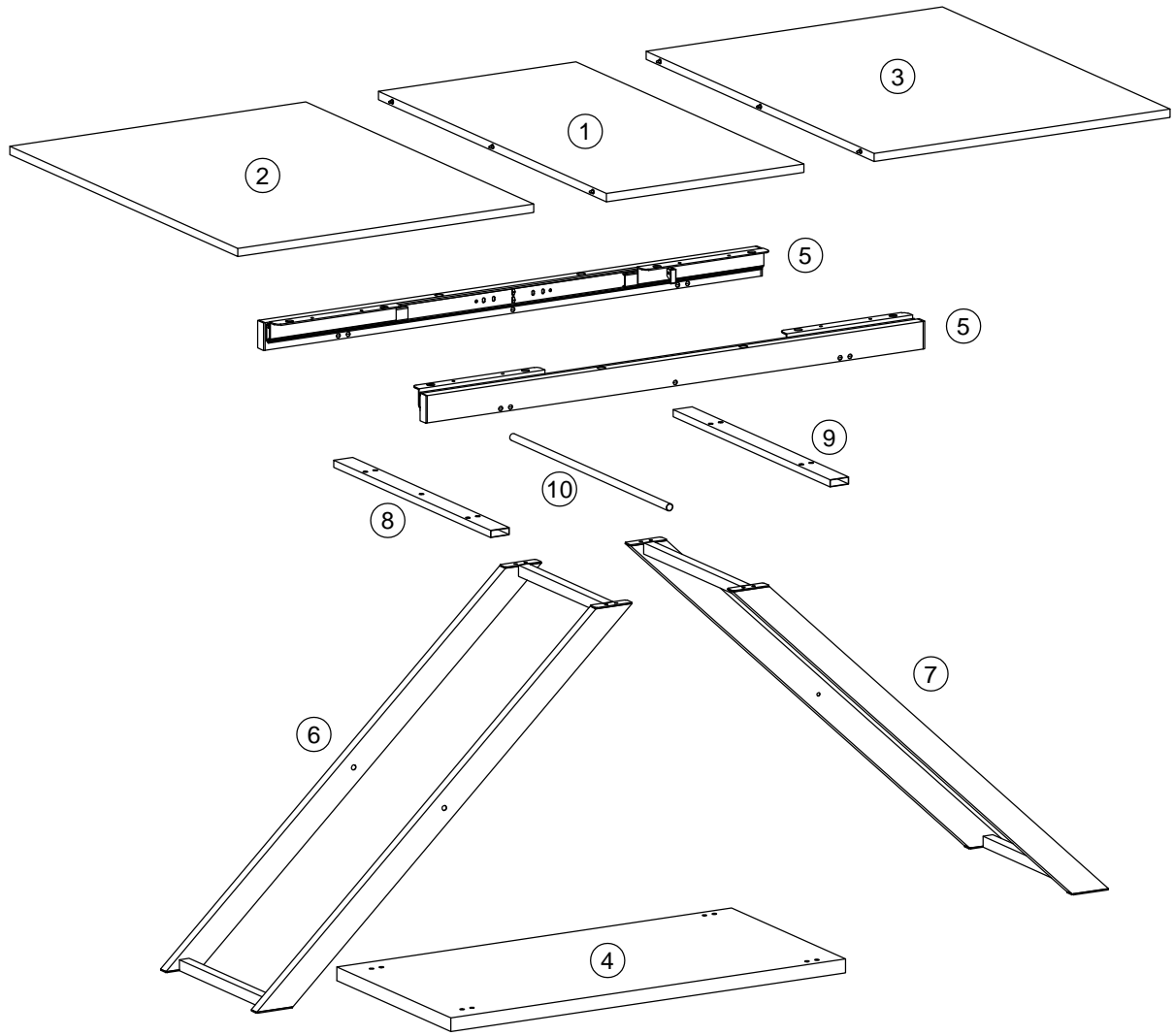

FR:Insérer la vis dans le trou avant la fin de l'assemblage, serrer la vis, mais ne pas serrer à 100%, 70% ~ 80% est correct. Enfin, une fois que toutes les vis sont bien serrées, toutes les vis sont serrées à 100%.Si vous rencontrez ces problèmes, par exemple si les trous ne sont pas alignés ou si certaines pièces ne peuvent pas être montées, vérifiez que les vis sont utilisées correctement et Ajustez leur serrage.

IT:Prima dell'installazione, inserire le viti nei fori e stringerle, ma non al 100%, è sufficiente stringerle al 70% - 80%. Infine, dopo aver installato tutte le viti, stringere tutte le viti al 100%. Se riscontri problemi come disallineamenti dei fori o difficoltà nell'installare alcuni componenti, verifica che le viti siano utilizzate correttamente e regola la tensione delle viti.

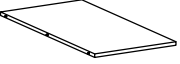

ES: Antes de la instalación, coloque los tornillos en los agujeros y apriételos, pero no al 100%; apretar al 70% - 80% es suficiente. Finalmente, después de haber instalado todos los tornillos, apriete todos los tornillos al 100%. Si se encuentra con problemas como desalineación de los agujeros o dificultad para instalar ciertas piezas, verifique que los tornillos se estén utilizando correctamente y ajuste la tensión de los tornillos

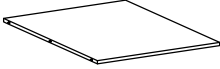



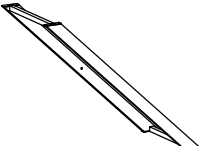
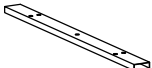
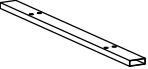
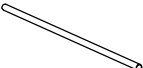

N620P224444

			
①×1pc	②×1pc	③×1pc	④×1pc

N620P224445

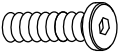
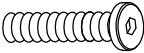
			
⑤×2pcs	⑥×1pc	⑦×1pc	⑧×1pc
			
⑨×1pc	⑩×1pc		

Hardware List  
 Hardwareliste N620P224445

 M6×12mm	 M6×30mm	 M6×40mm	 φ19×3mm	 φ18×1.8mm
Ⓐ×12pcs	Ⓑ×12pcs	Ⓒ×16pcs	Ⓓ×4pcs	Ⓔ×8pcs
 Ⓕ×4pcs	 M4 Ⓖ×1pc			

# Step 1 Schritt 1

 φ19x3mm	 M6x12mm
 ×4pcs	 ×4pcs

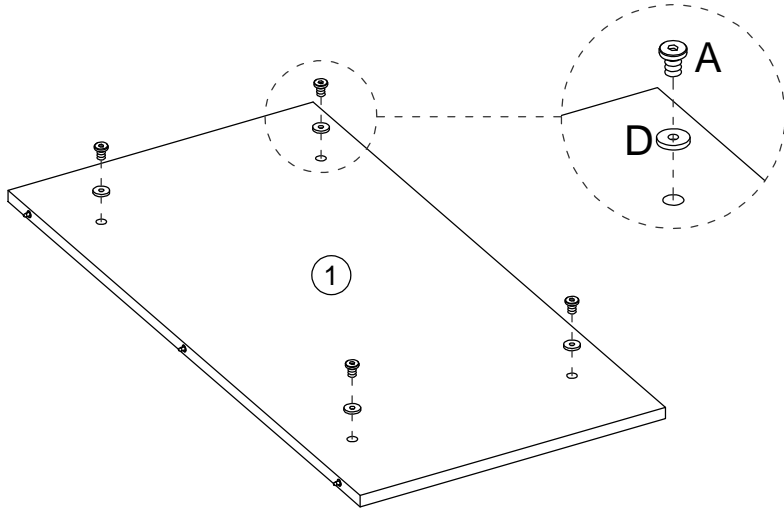

~~φ18x1.8mm~~  
φ19x3mm

# Step 2 Schritt 2

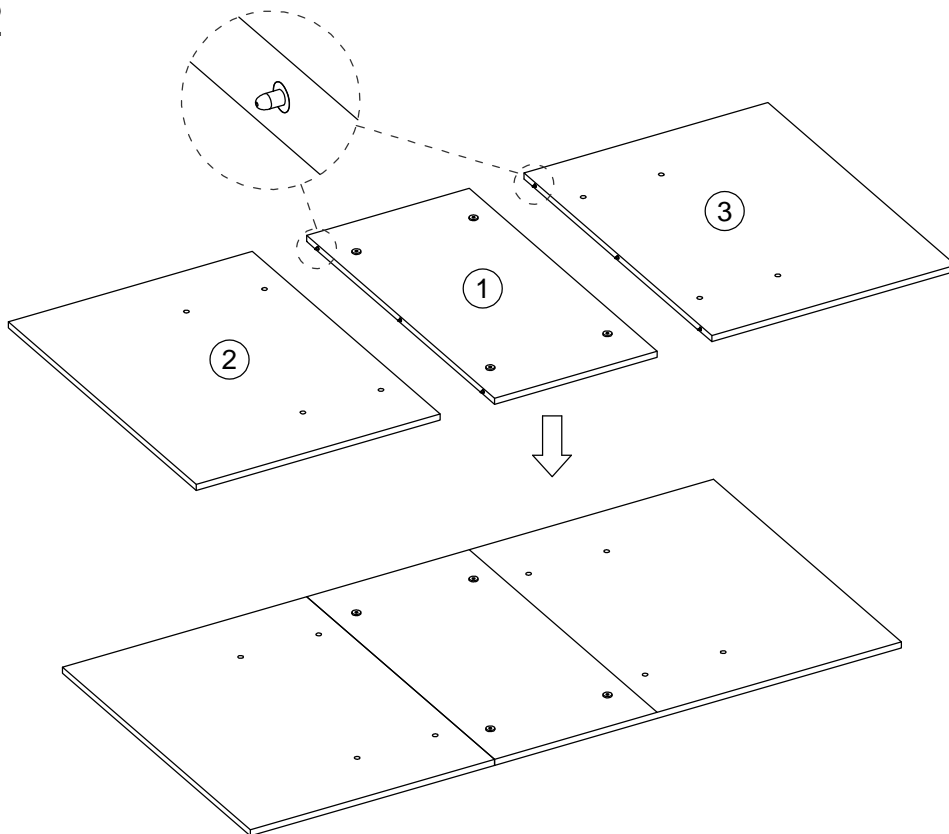



Step 3  
Schritt 3



M6×30mm

ⓑ×2pcs

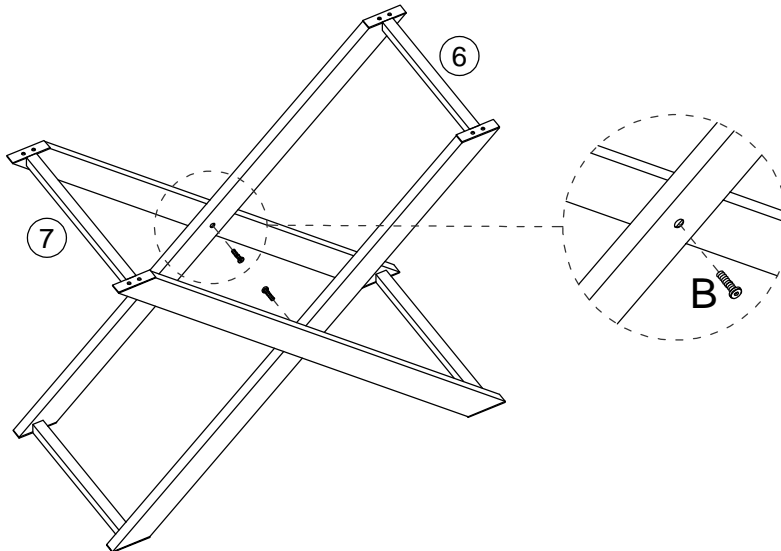

Step 4  
Schritt 4



M6×30mm

ⓑ×8pcs

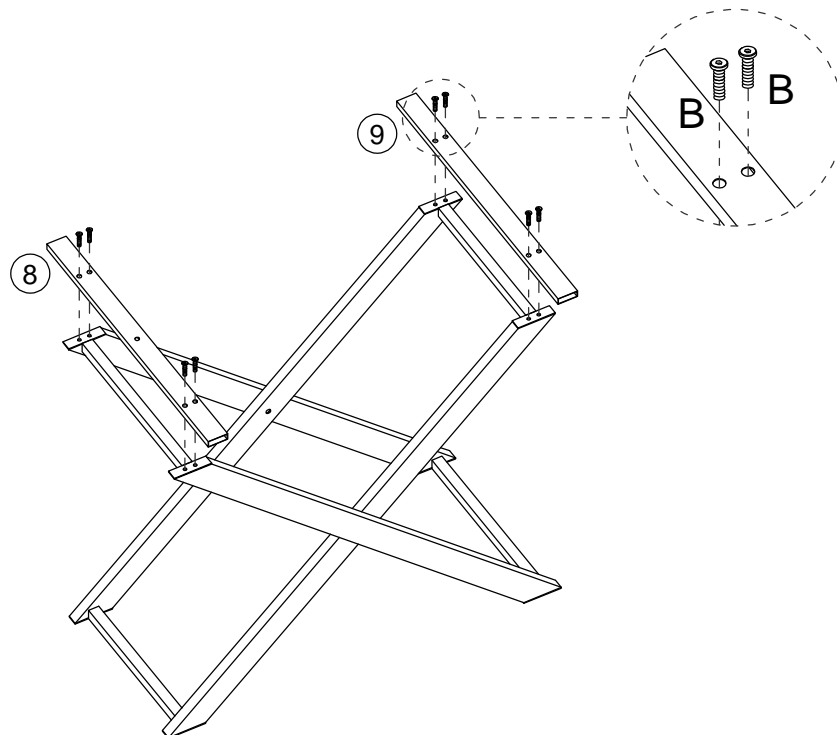

# Step 5 Schritt 5

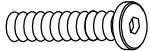
M6×40mm
ⓐ × 8pcs

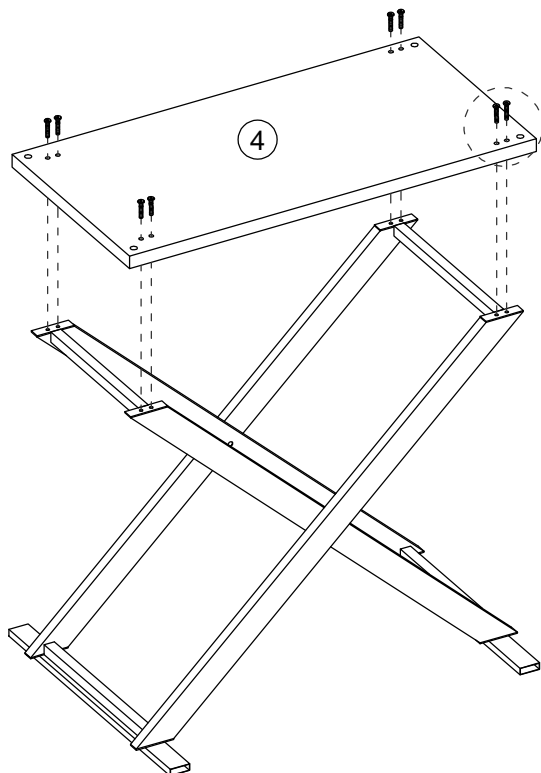

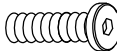
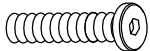

# Step 6 Schritt 6

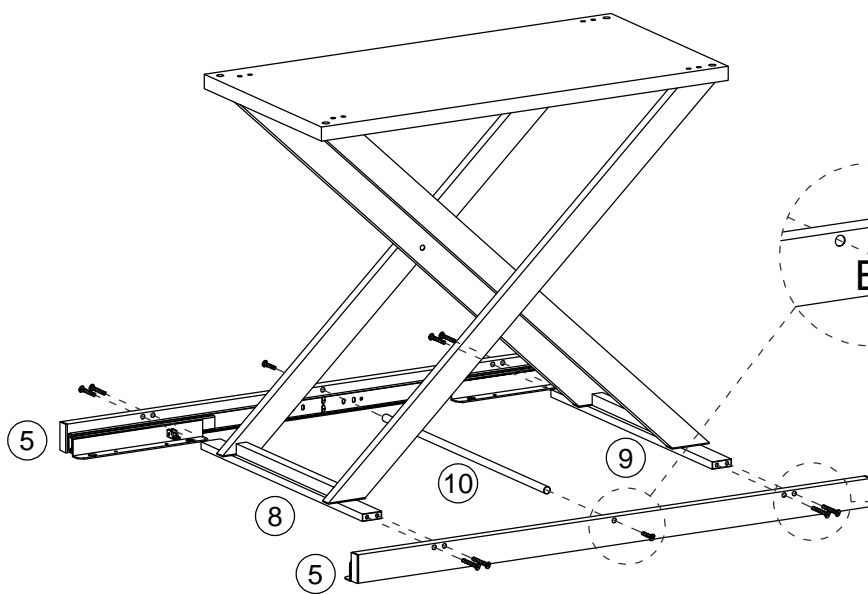
	
M6×30mm	M6×40mm
ⓑ × 2pcs	Ⓒ × 8pcs



# Step 7 Schritt 7

	
φ18x1.8mm	M6×12mm
ⓔ×8pcs	ⓐ×8pcs

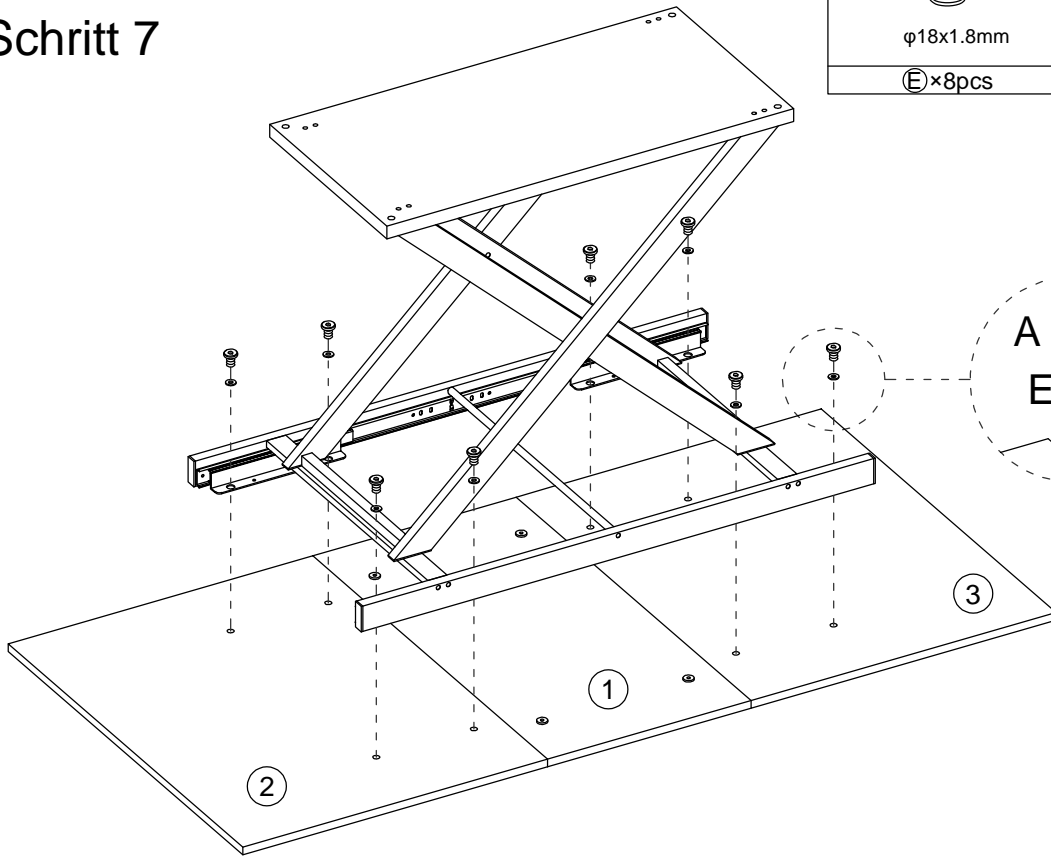

# Step 8 Schritt 8

ⓕ×4pcs

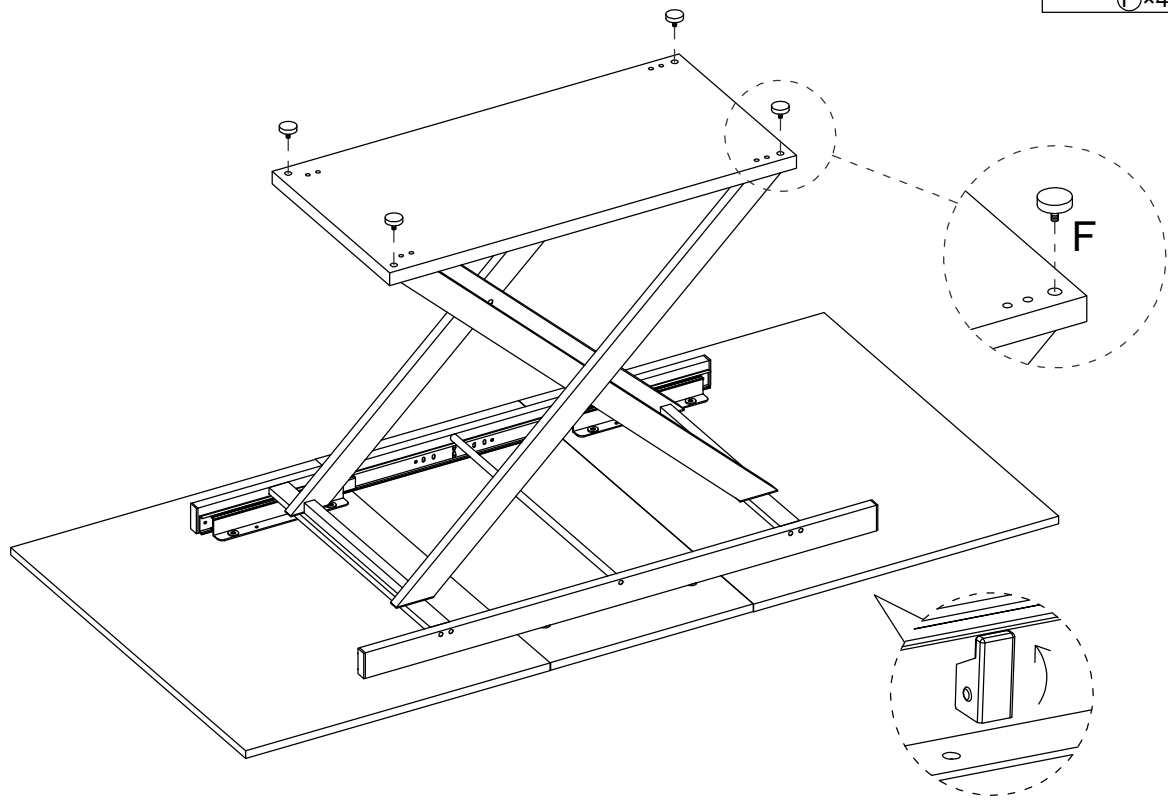

Step 9

Schritt 9

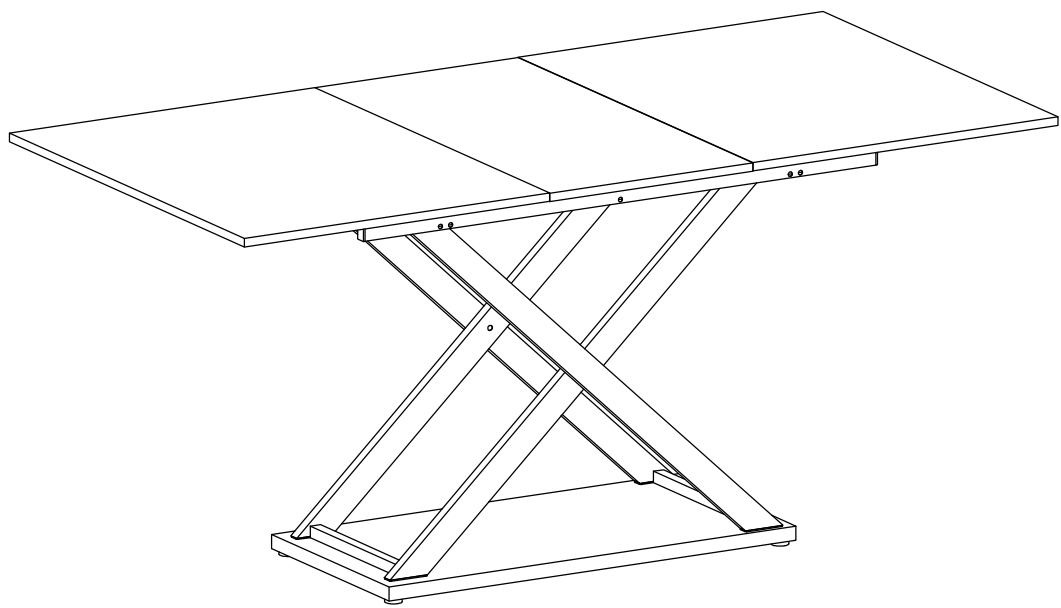

Step 10  
Schritt 10

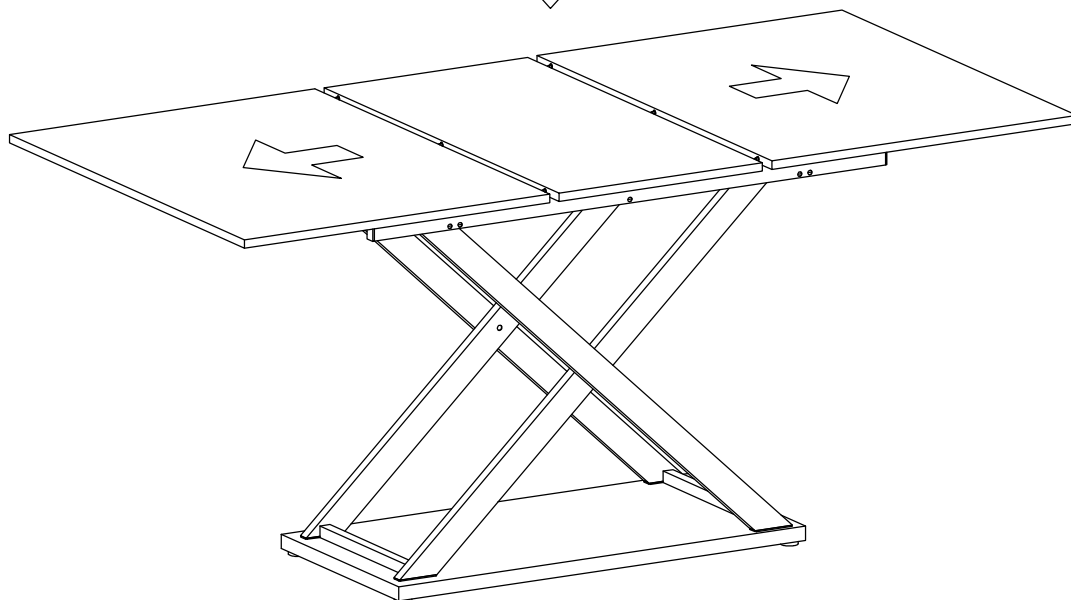
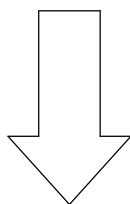
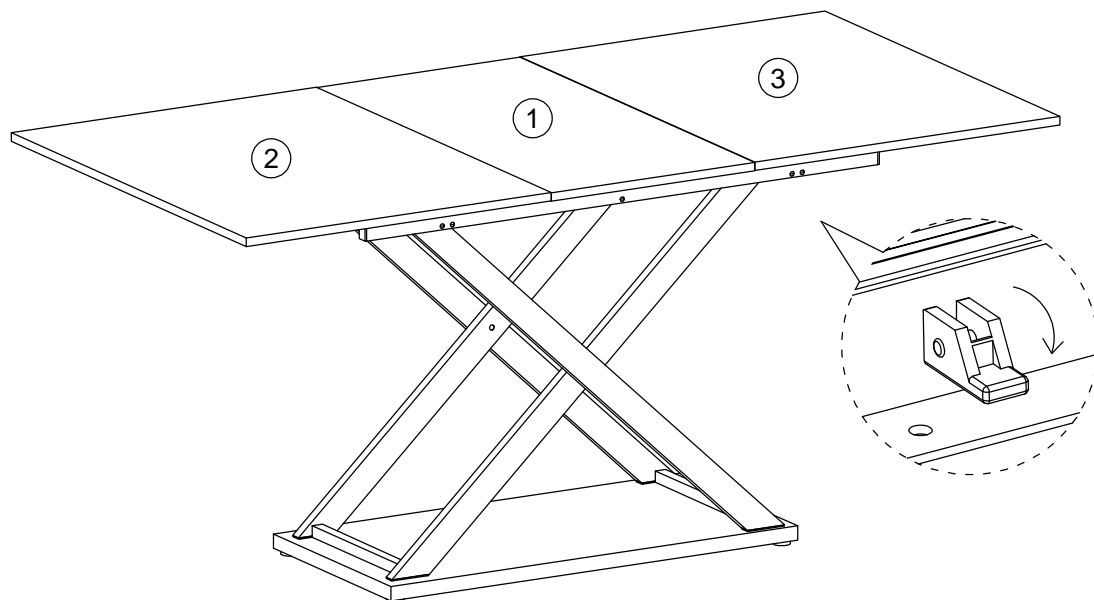

Step 11  
Schritt 11

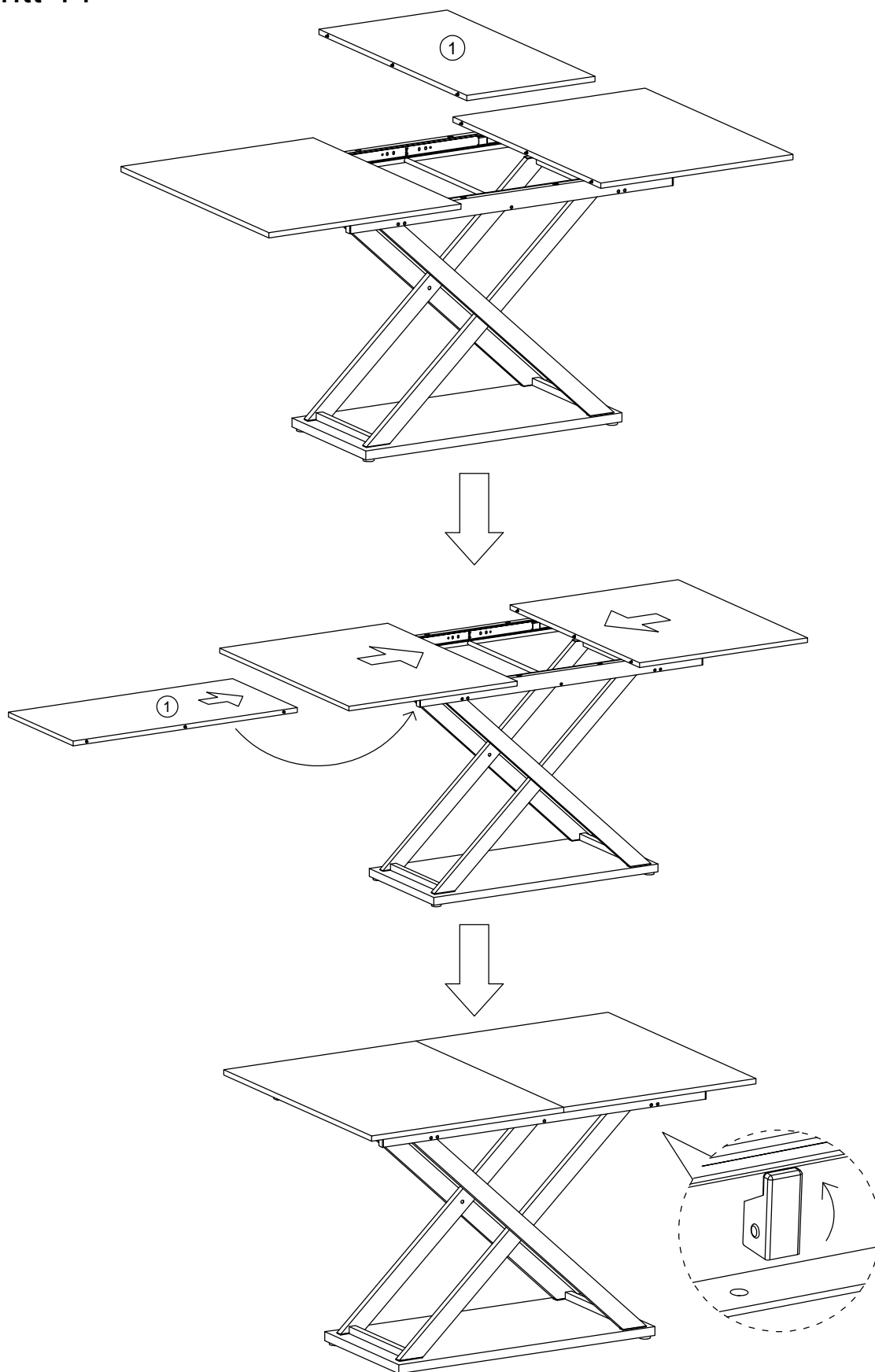

Step 12  
Schritt 12

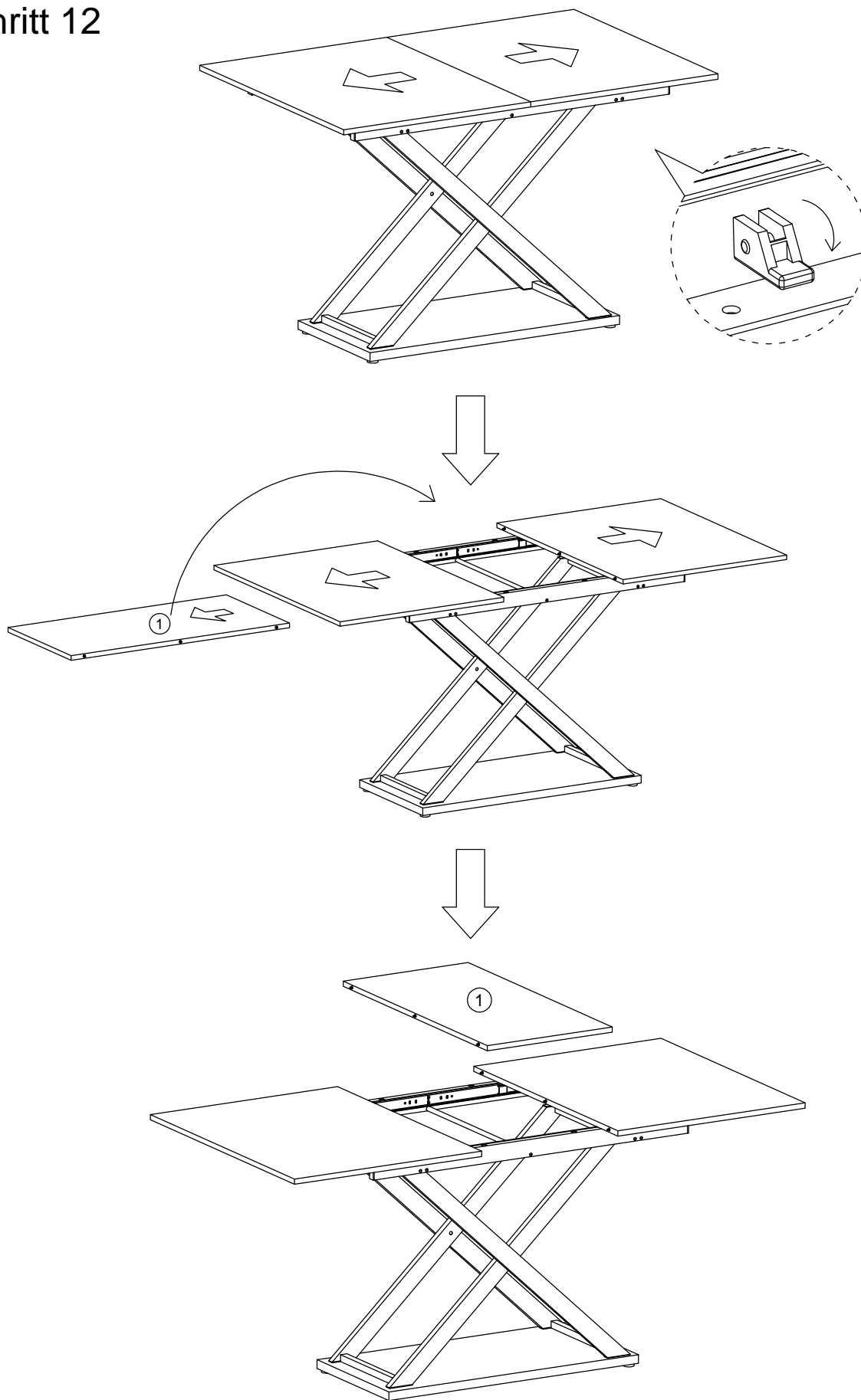

Step 13  
Schritt 13

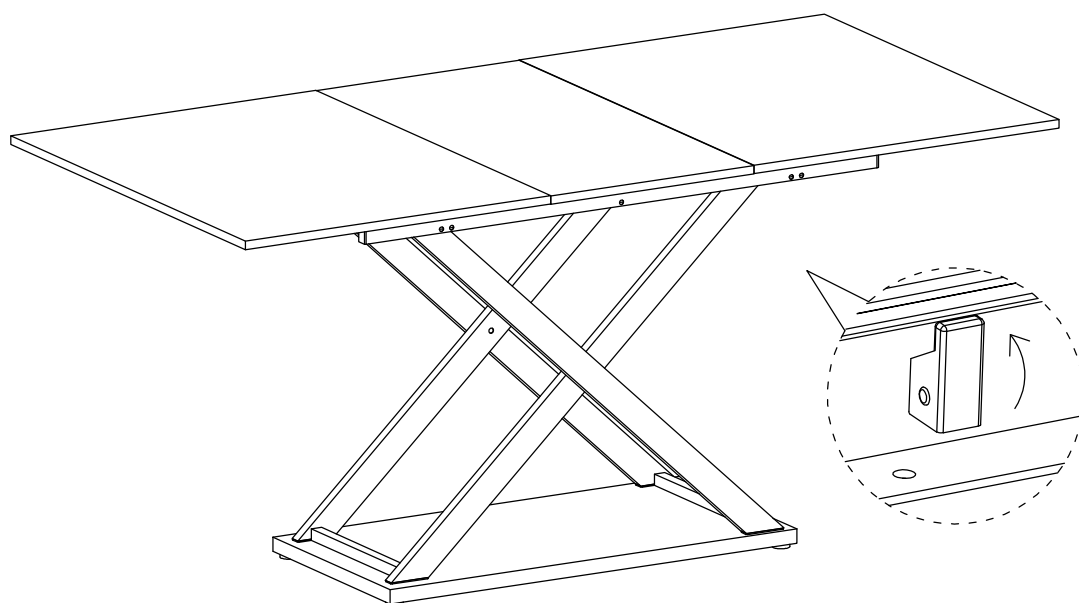
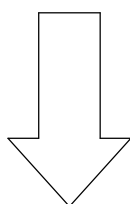



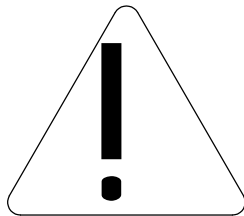

DE

Warnung

- 1 Die maximale Tragfähigkeit des Produkts beträgt 60 kg. Überladen vermeiden.
- 2 Kinder dürfen nicht auf Möbel klettern, da dies zu Kippen und schweren Verletzungen führen kann.
- 3 Um die Sicherheit zu gewährleisten, installieren Sie bitte gemäß den Anweisungen korrekt und holen Sie bei Bedarf professionelle Hilfe ein.
- 4 Stellen Sie Möbel nicht in der Nähe von Wärmequellen oder heißen Gegenständen auf, um Brandgefahr zu vermeiden.
- 5 Vermeiden Sie es, Möbel in feuchten Umgebungen zu platzieren, um Materialschäden zu vermeiden.
- 6 Überprüfen Sie regelmäßig alle Verbindungsstücke und Befestigungen, um sicherzustellen, dass sie fest sitzen und unerwartete Unfälle zu verhindern.
- 7 Reinigen Sie Möbel mit einem feuchten Tuch oder Alkohol, vermeiden Sie die Verwendung von Reinigungsmitteln, die ätzende Chemikalien enthalten.

UK

Warning

- 1 The maximum load capacity of the product is 60kg. Do not overload.
- 2 Children should not climb on furniture, as this may cause tipping and serious injuries.
- 3 To ensure safety, please install according to the instructions correctly, and seek professional assistance if necessary.
- 4 Do not place furniture near heat sources or hot items to avoid the risk of fire.
- 5 Do not place furniture in damp environments to prevent material damage.
- 6 Regularly check all connections and fasteners to ensure they are secure to prevent accidents.
- 7 Clean furniture with a damp cloth or alcohol, avoid using cleaning agents containing corrosive chemicals.

FR

Avertissement

- 1 La charge maximale du produit est de 60 kg. Ne pas surcharger.
- 2 Les enfants ne doivent pas grimper sur les meubles, car cela peut entraîner un renversement et des blessures graves.
- 3 Pour assurer la sécurité, veuillez installer correctement selon les instructions et demander une assistance professionnelle si nécessaire.
- 4 Ne placez pas les meubles près de sources de chaleur ou d'objets chauds pour éviter les risques d'incendie.
- 5 Évitez de placer les meubles dans des environnements humides pour éviter les dommages aux matériaux.
- 6 Vérifiez régulièrement toutes les connexions et les fixations pour vous assurer qu'elles sont sécurisées et prévenir les accidents.
- 7 Nettoyez les meubles avec un chiffon humide ou de l'alcool, évitez d'utiliser des agents de nettoyage contenant des produits chimiques corrosifs.

IT

Avviso

- 1 La capacità massima del prodotto è di 60 kg. Non sovraccaricare.
- 2 I bambini non devono arrampicarsi sui mobili, poiché ciò potrebbe causare il ribaltamento e gravi lesioni.
- 3 Per garantire la sicurezza, installare correttamente secondo le istruzioni e chiedere assistenza professionale se necessario.
- 4 Non posizionare i mobili vicino a fonti di calore o oggetti caldi per evitare il rischio di incendio.
- 5 Evitare di posizionare i mobili in ambienti umidi per evitare danni ai materiali.
- 6 Controllare regolarmente tutte le connessioni e i fissaggi per assicurarsi che siano sicuri e prevenire gli incidenti.
- 7 Pulire i mobili con un panno umido o alcool, evitare l'uso di agenti di pulizia contenenti sostanze chimiche corrosive.

ES

Aviso

- 1 La capacidad máxima de carga del producto es de 60 kg. No sobrecargar.
- 2 Los niños no deben trepar sobre los muebles, ya que esto puede causar que se vuelquen y provocar lesiones graves.
- 3 Para garantizar la seguridad, instale correctamente según las instrucciones y busque asistencia profesional si es necesario.
- 4 No coloque los muebles cerca de fuentes de calor o objetos calientes para evitar el riesgo de incendio.
- 5 Evite colocar los muebles en entornos húmedos para evitar daños en los materiales.
- 6 Revise regularmente todas las conexiones y sujeciones para asegurarse de que estén seguras y prevenir accidentes.
- 7 Limpie los muebles con un paño húmedo o alcohol, evite el uso de agentes de limpieza que contengan productos químicos corrosivos.