

N625P170655

N625P170656

Product manual
 Gebrauchsanweisung
 Manuel du produit
 Manual del producto
 Manuale del prodotto

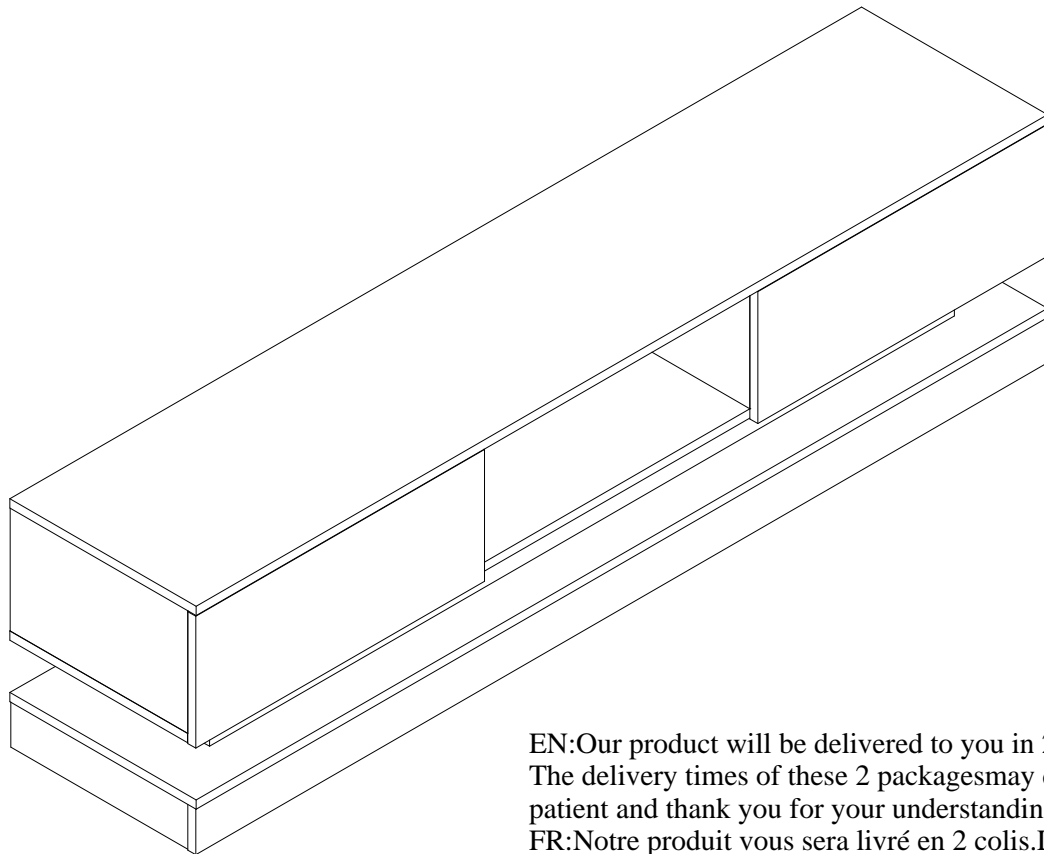

EN:Our product will be delivered to you in 2 packages. The delivery times of these 2 packages may differ, please be patient and thank you for your understanding
 FR:Notre produit vous sera livré en 2 colis. Les délais de livraison de ces 2 colis peuvent différer, soyez patient et merci de votre compréhension.
 DE:Unser Produkt wird Ihnen in 2 Paketen geliefert. Die Lieferzeiten dieser 2 Pakete können abweichen, bitte haben Sie etwas Geduld und vielen Dank für Ihr Verständnis
 IT:I nostri prodotti vengono trasportati in due pacchetti. I tempi di consegna dei due pacchetti sono diversi: abbiate pazienza e vi ringrazio per la vostra comprensione.
 ES:Nuestro producto se entrega en dos paquetes. El tiempo de entrega de estos dos paquetes es diferente. Por favor, sea paciente. Gracias por su comprensión.

Importeur	Decobus Handel GmbH
Adresse	Innungsstraße 9, 21244 Buchholz, Deutschland
URL	https://www.decobusgroup.de
Hersteller	SHOUGUANG BOMAO TRADING CO.,LTD
Adresse	200 METERS SOUTH OF THE VILLAGE OFFICE OF DONGQI, SHENGCHENG STREET, SHOUGUANG CITY, SHANDONG, CHINA
Email/URL	https://bomaotrading.en.alibaba.com
EC REP	Decobus Handel GmbH Innungsstraße 9, 21244 Buchholz, Deutschland

 2PERS	 45 MIN	Tool Required Not Provided	



[DE]

Warnung: Dieses Produkt ist mit einer Kippsicherung ausgestattet. Bitte installieren Sie dieses Gerät unbedingt, um unnötige Verletzungen durch Umkippen zu vermeiden.

Warnung: Erlauben Sie Kindern nicht, auf die Möbel zu klettern, da dies zum Umkippen und zu schweren Verletzungen führen kann.

Warnung: Um die Sicherheit zu gewährleisten, befolgen Sie bitte die Anweisungen zur korrekten Installation und holen Sie sich bei Bedarf professionelle Hilfe.

Warnung: Stellen Sie Möbel nicht in der Nähe von Feuerquellen oder Gegenständen mit hoher Temperatur auf, um Brandgefahr zu vermeiden.

[EN]

Warning: This product is equipped with an anti-tilt device. Please be sure to install this device to prevent unnecessary injuries caused by tipping.

Warning: Do not allow children to climb on the furniture as this may result in tipping and serious personal injury.

Warning: To ensure safety, please follow the instructions for correct installation and seek professional assistance if necessary.

Warning: Do not place furniture close to fire sources or high-temperature objects to avoid the risk of fire.

[FR]

Avertissement : Ce produit est équipé d'un dispositif anti-basculement. Assurez-vous d'installer cet appareil pour éviter les blessures inutiles causées par le basculement.

Avertissement : Ne laissez pas les enfants grimper sur les meubles car cela pourrait entraîner un basculement et des blessures graves.

Avertissement : pour garantir la sécurité, veuillez suivre les instructions pour une installation correcte et demander l'aide d'un professionnel si nécessaire.

Avertissement : Ne placez pas les meubles à proximité de sources d'incendie ou d'objets à haute température pour éviter tout risque d'incendie.

[IT]

Attenzione: questo prodotto è dotato di un dispositivo antiribaltamento. Assicurarsi di installare questo dispositivo per evitare lesioni inutili causate dal ribaltamento.

Attenzione: non permettere ai bambini di arrampicarsi sui mobili poiché ciò potrebbe causare ribaltamento e gravi lesioni personali.

Attenzione: per garantire la sicurezza, seguire le istruzioni per una corretta installazione e, se necessario, richiedere assistenza professionale.

Attenzione: non posizionare i mobili vicino a fonti di fuoco o oggetti ad alta temperatura per evitare il rischio di incendio.

[ES]

Advertencia: Este producto está equipado con un dispositivo antivuelco. Asegúrese de instalar este dispositivo para evitar lesiones innecesarias causadas por vuelcos.

Advertencia: No permita que los niños se suban a los muebles, ya que esto podría provocar vuelcos y lesiones personales graves.

Advertencia: Para garantizar la seguridad, siga las instrucciones para una instalación correcta y busque asistencia profesional si es necesario.

Advertencia: No coloque muebles cerca de fuentes de fuego u objetos de alta temperatura para evitar el riesgo de incendio.

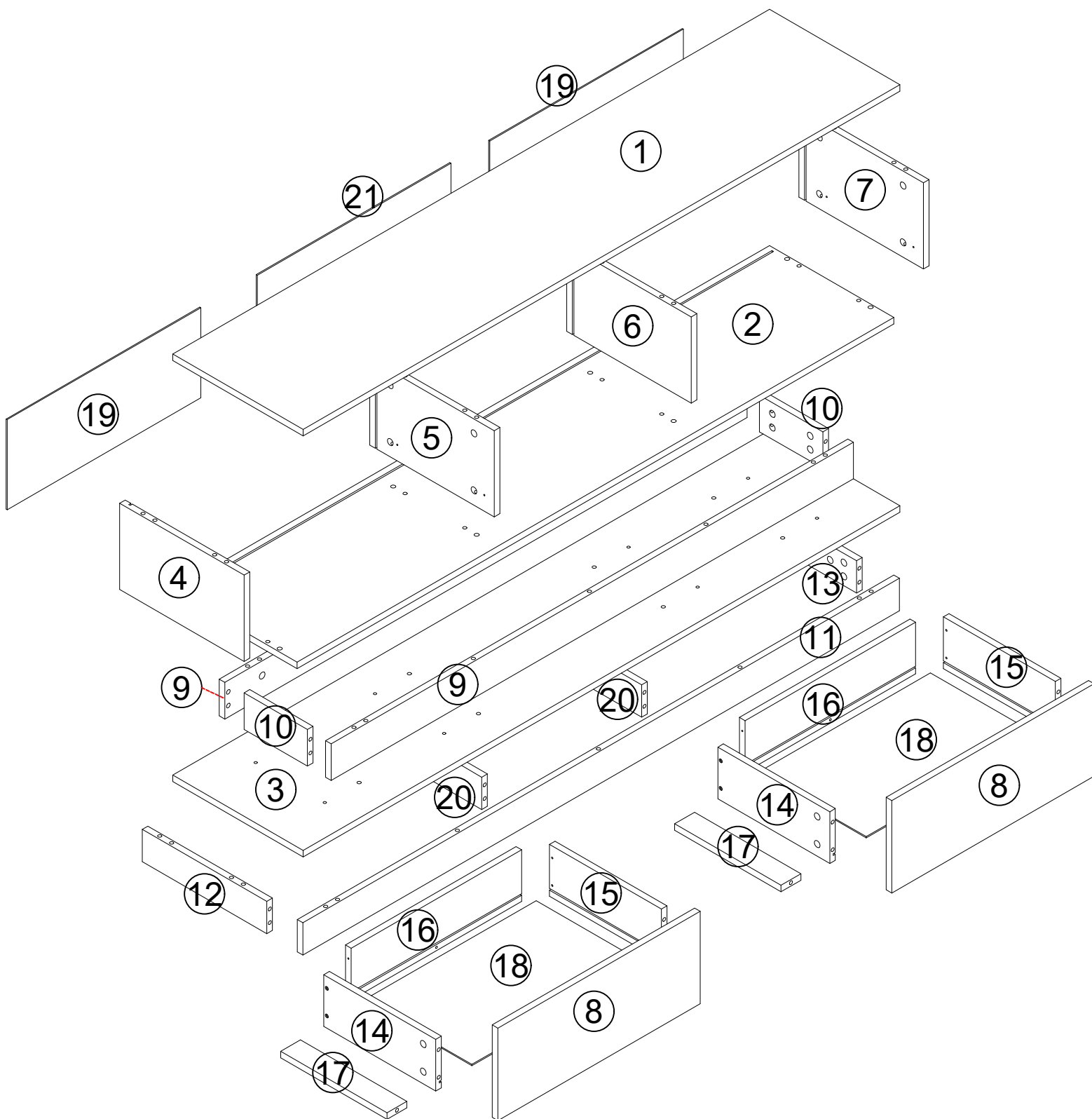

BOX-1/2
N625P170655

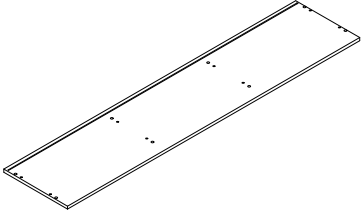
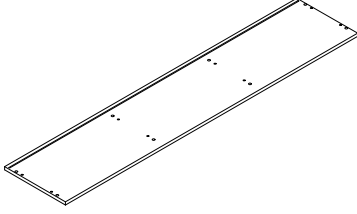
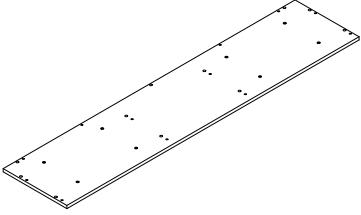
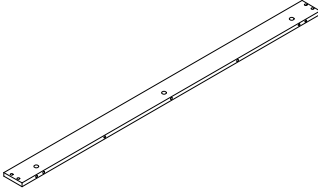
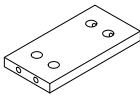
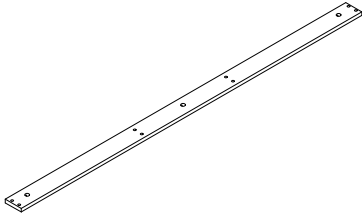
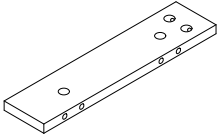
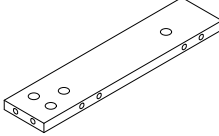
①		1
②		1
③		1
⑨		2
⑩		2
⑪		1
⑫		1
⑬		1

BOX-2/2
N625P170656

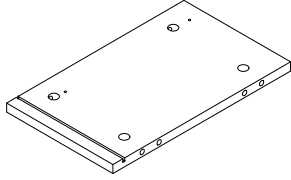
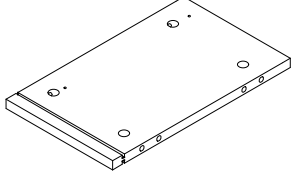
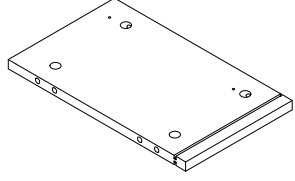
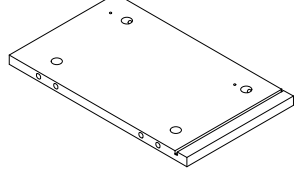
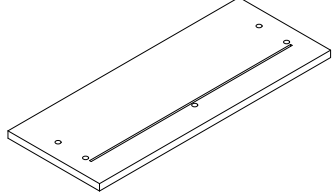
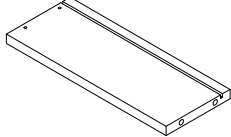
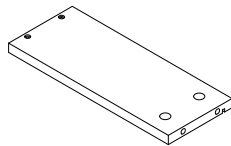
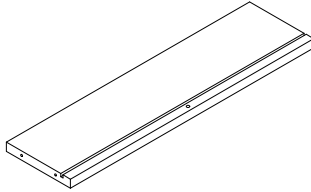
④		1
⑤		1
⑥		1
⑦		1
⑧		2
⑭		2
⑮		2
⑯		2



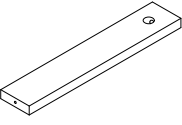
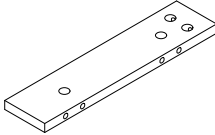

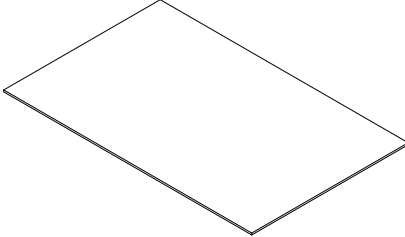
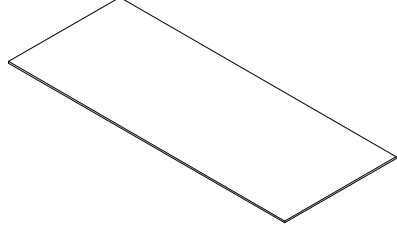
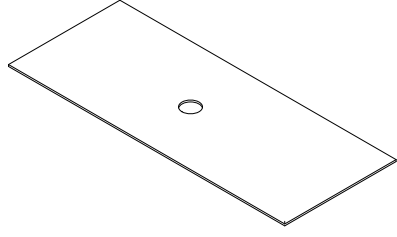
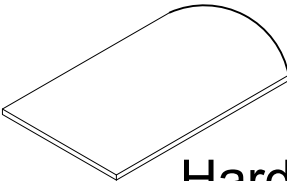

BOX-1/2
N625P170655

①7		2
②0		2

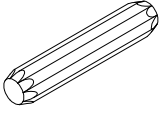
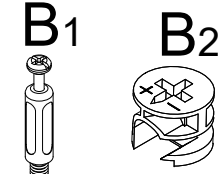
BOX-2/2
N625P170656

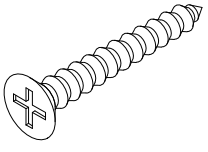
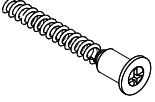
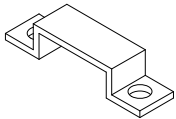
①8		2
①9		2
②1		1
 Hardware kit		

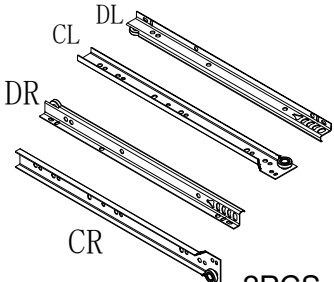
Hardware List for N625P170655/N625P170656

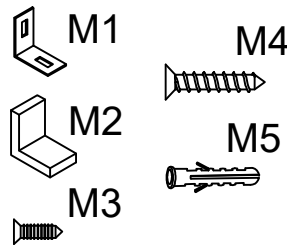
<p>A M8*40</p>  <p>44PCS</p>	<p>B</p> <p>B1 B2</p>  <p>M6*40 59PCS</p>	<p>C M3.5*14</p>  <p>44PCS</p>	<p>D M3.5*35</p>  <p>10PCS</p>
<p>E M7*50</p>  <p>8PCS</p>	<p>F</p>  <p>8PCS</p>	<p>G</p>  <p>1PCS</p>	<p>H</p>  <p>12PCS</p>
<p>I</p> <p>CL DL</p> <p>DR</p> <p>CR</p>  <p>2PCS</p>	<p>K</p>  <p>59PCS</p>	<p>M</p> <p>M1 M2 M3</p> <p>M4 M5</p>  <p>2PCS</p>	

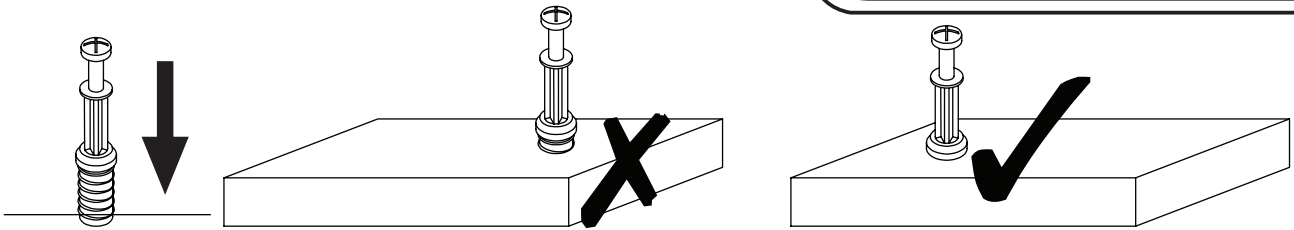

EN_QUICKFIT: Tighten quickfit until shoulder is flush with panel. Do not overtighten or undertighten.

FR_RACCORD RAPIDE: Faites serrer le raccord rapide jusqu'à ce que l'épaulement soit parfaitement encastré dans le panneau. Il ne faut ni trop serrer ni insuffisamment serrer.

ES_QUICKFIT: Apriete quickfit hasta que el hombro se descargue con el panel. NO lo sobreapriete ni lo apriete poco.

DE_QUICKFIT: Ziehen Sie den Quickfit fest, bis die Schulter mit der Platte bündig ist. Bitte nicht zu fest oder zu schwach anziehen.

IT_MONTAGGIO RAPIDO: Stringere il montaggio rapido fino a quando la spalla è a filo con il pannello, non stringere troppo o troppo poco.

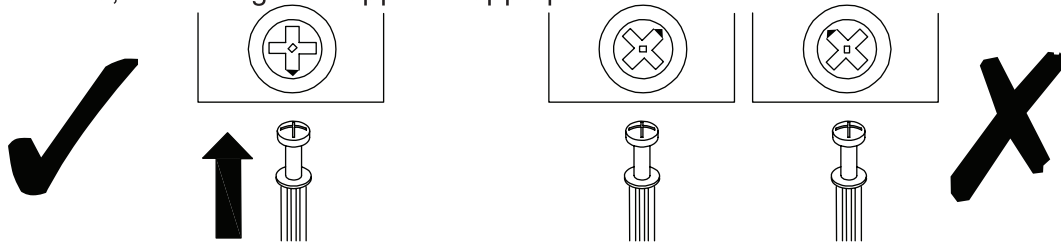

EN_CAM LOCK: When fitting cam lock, ensure starting position is correct before you insert connecting quickfit.

FR_SERRURE BATTEUSE: Avant d'insérer la serrure batteuse, veillez à la bonne orientation avant d'insérer le raccord rapide.

ES_CIERRE DE LA CÁMARA: Cuando instale el cierre de la cámara, asegúrese de que la posición de inicio es correcta antes de que inserte el quickfit conector.

DE_CAM-LOCK: Achten Sie bei der Montage des Cam-Locks auf die richtige Ausgangsposition, bevor Sie den Quickfit einsetzen.

IT_BLOCCAGGIO A CAMMA: Quando si monta il bloccaggio a camma, assicurarsi che la posizione iniziale sia corretta prima di inserire il montaggio rapido di collegamento.

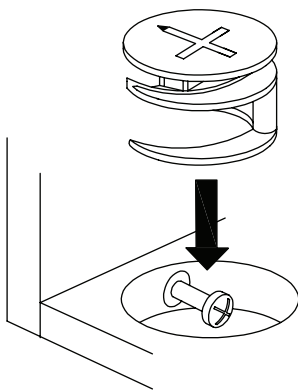

EN_Quickfit head should be in the centre of the cam lock when the two panels are joined.

Cam lock should be inserted before quickfit.

FR_Lorsque les deux panneaux sont assemblés, la tête du raccord rapide doit reposer au centre de la serrure batteuse. Il faut insérer la serrure batteuse avant le raccord rapide.

ES_El cabezal del quickfit debe estar en el centro del cierre de la cámara cuando se unan los dos paneles.

Se debe insertar el cierre de la cámara antes que el quickfit.

DE_Der Quickfit-Kopf sollte sich in der Mitte des Cam-Locks befinden, wenn die beiden Platten zusammengefügt sind. Der Cam-Lock sollte vor dem Quickfit eingesetzt werden.

IT_La testa del montaggio rapido deve trovarsi al centro del bloccaggio a camma quando i due pannelli sono uniti.

Il Bloccaggio a Camma deve essere inserito prima del montaggio rapido.

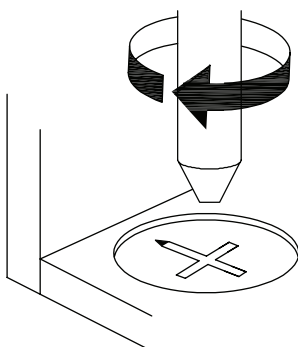

EN_Turn cam lock clockwise to tighten.

FR_Faites tourner la serrure batteuse dans le sens des aiguilles d'une montre pour la resserrer.



ES_Gire el cierre de la cámara en sentido horario para apretarlo.

DE_Drehen Sie den Cam-Lock im Uhrzeigersinn, um ihn festzuziehen.

IT_Ruotare il bloccaggio a camma in senso orario per stringere.

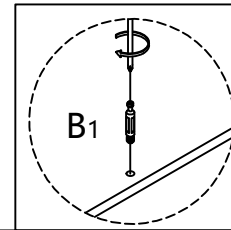
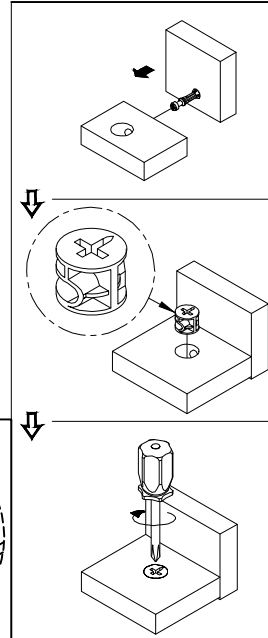
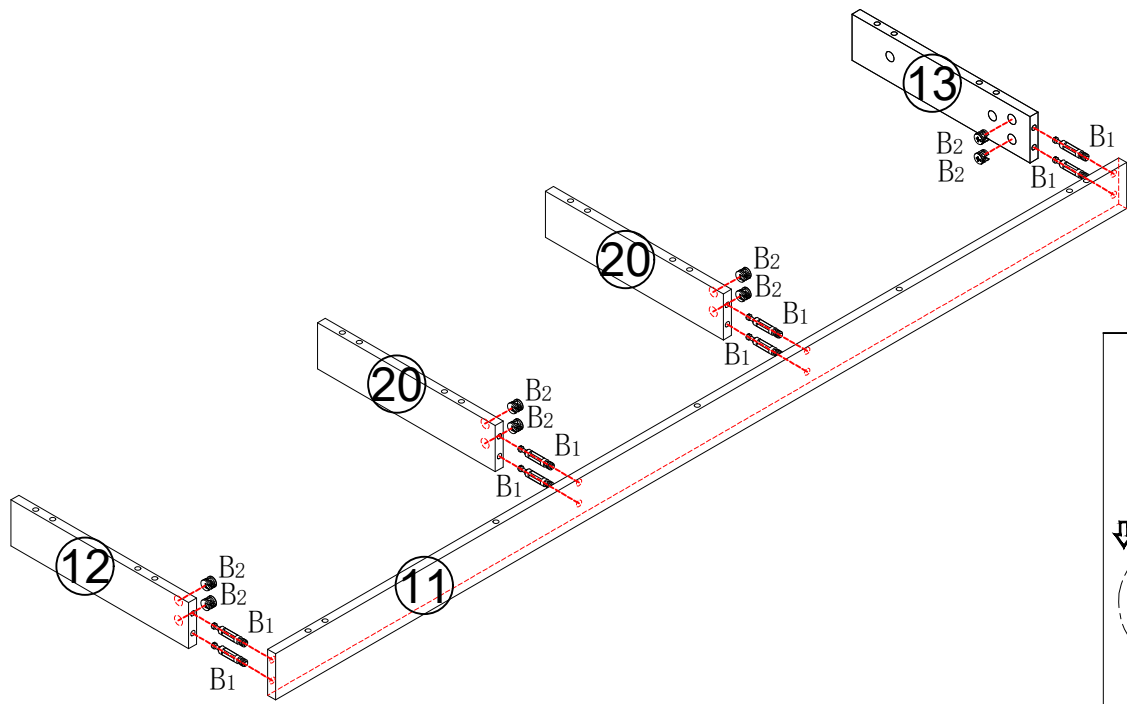

STEP 1



	B ₁ x8pcs
	B ₂ x8pcs

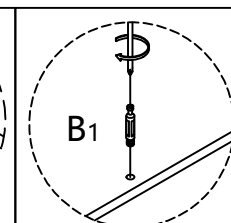
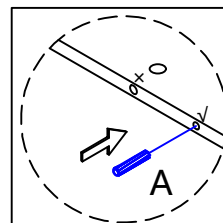
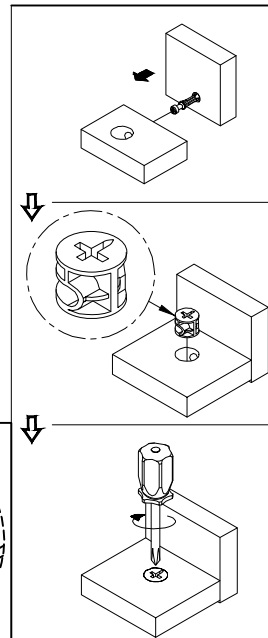
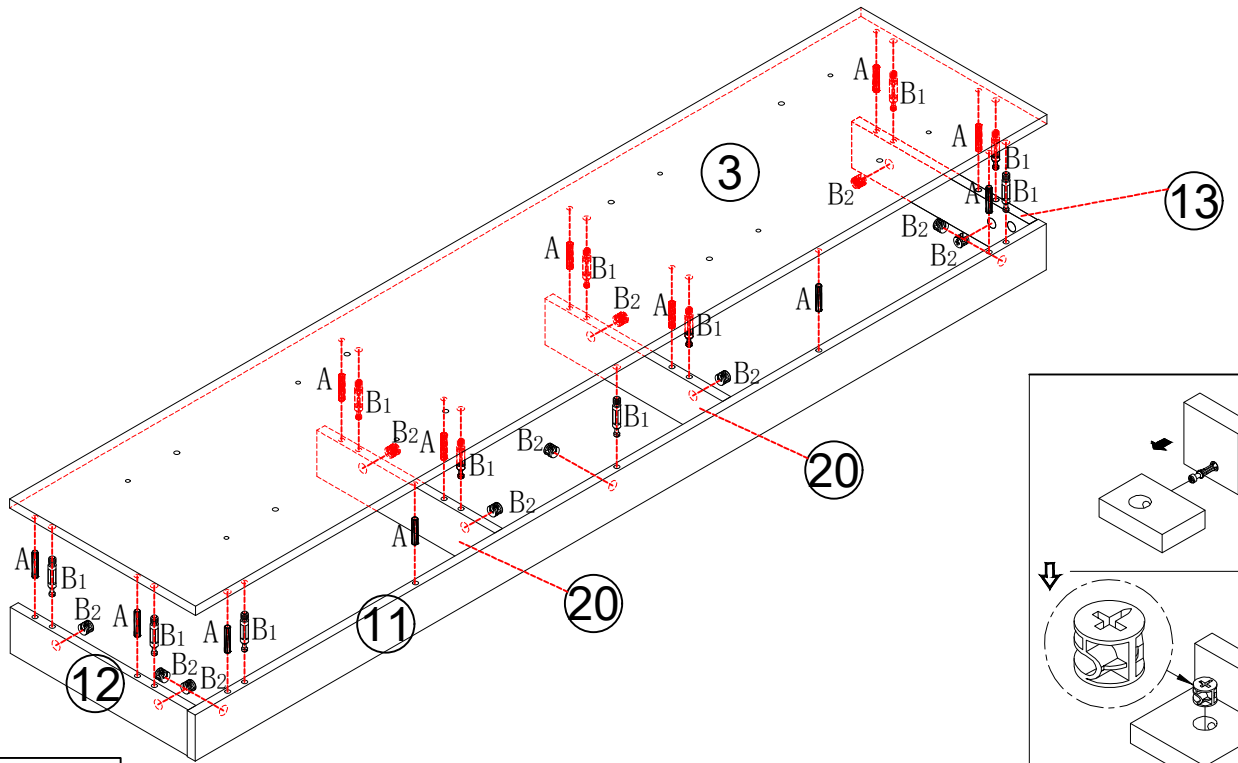

STEP 2



	Ax12pcs
	B ₁ x11pcs
	B ₂ x11pcs

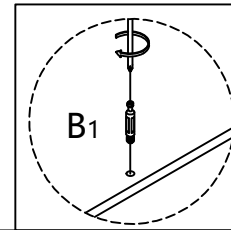
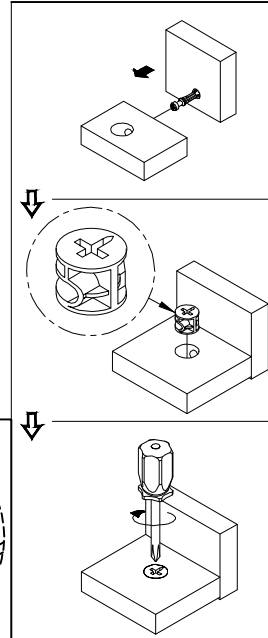
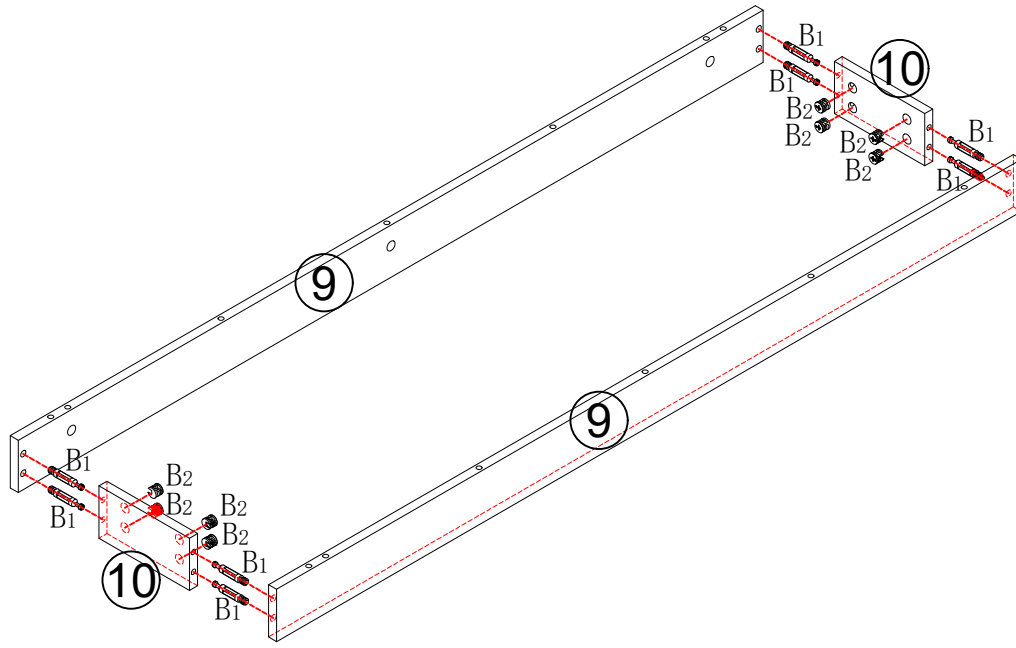

STEP 3

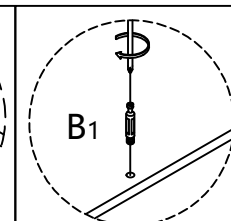
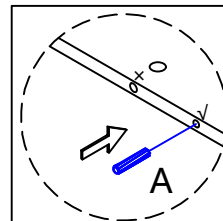
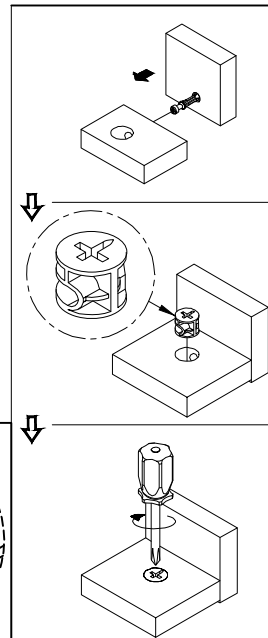
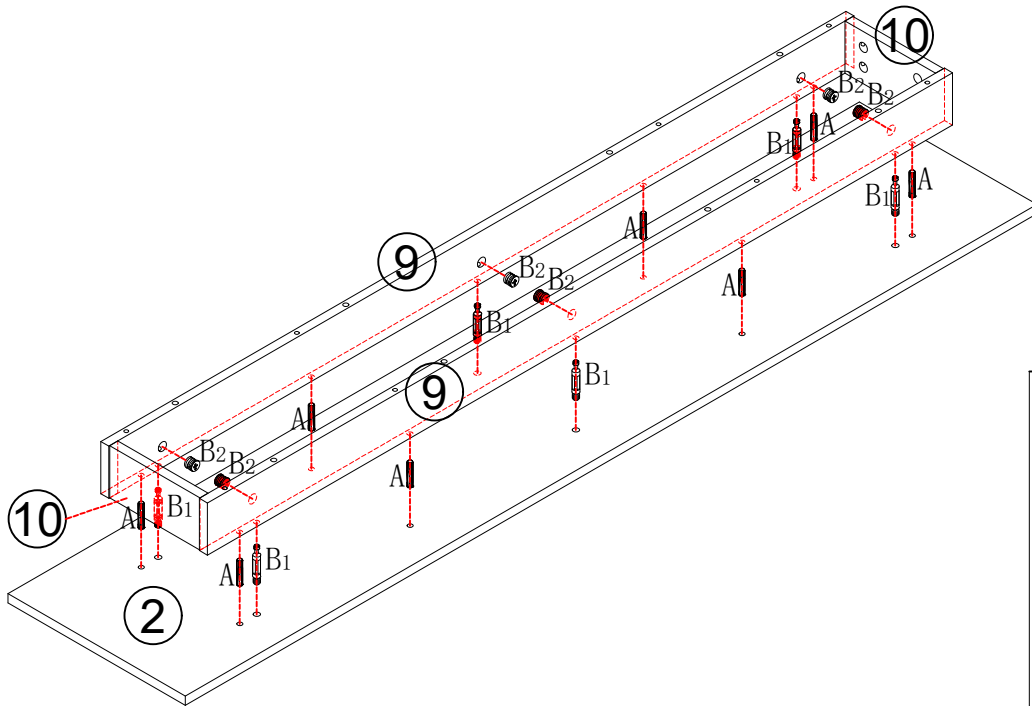

	B ₁ x8pcs
	B ₂ x8pcs

STEP 4





	Ax8pcs
	B ₁ x6pcs
	B ₂ x6pcs

STEP 5

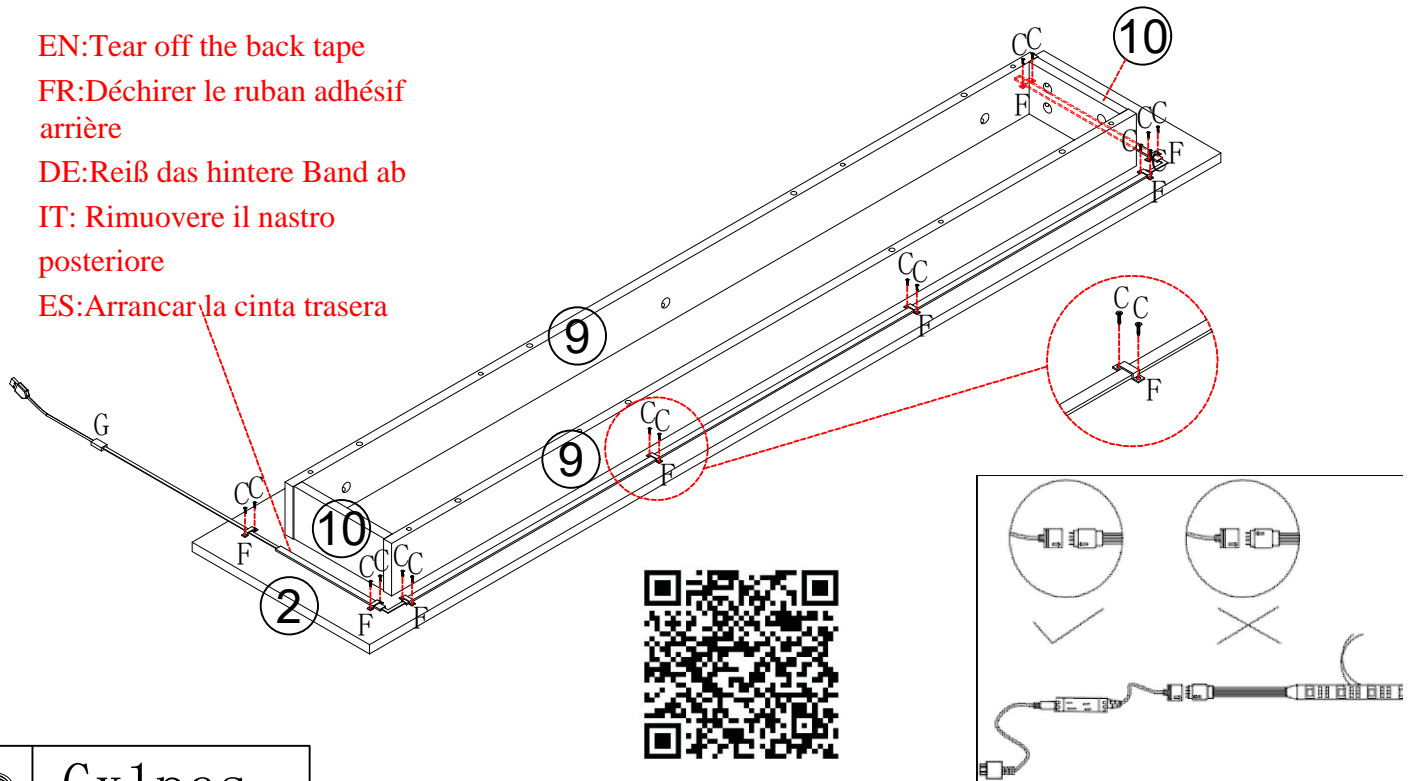
EN:Tear off the back tape
 FR:Déchirer le ruban adhésif arrière
 DE:Reiß das hintere Band ab
 IT: Rimuovere il nastro posteriore
 ES:Arrancar la cinta trasera





	Gx1pcs
	Fx8pcs
	Cx16pcs

EN:Scan to download App control the Led light.
 DE:Das led-display wird durchsucht.
 FR:Scanner pour télécharger App contrôler la lumière Led.
 IT:Scansiona per scaricare l'applicazione controlla la luce Led.
 ES:Analice para descargar la aplicación control de la luz Led.

UK: The connection of light stripe
 DE: Die Verbindung von Lichtstreifen
 FR: La connexion de la bande lumineuse
 IT:La connessione della striscia di luce
 ES:La conexión de la franja de luz

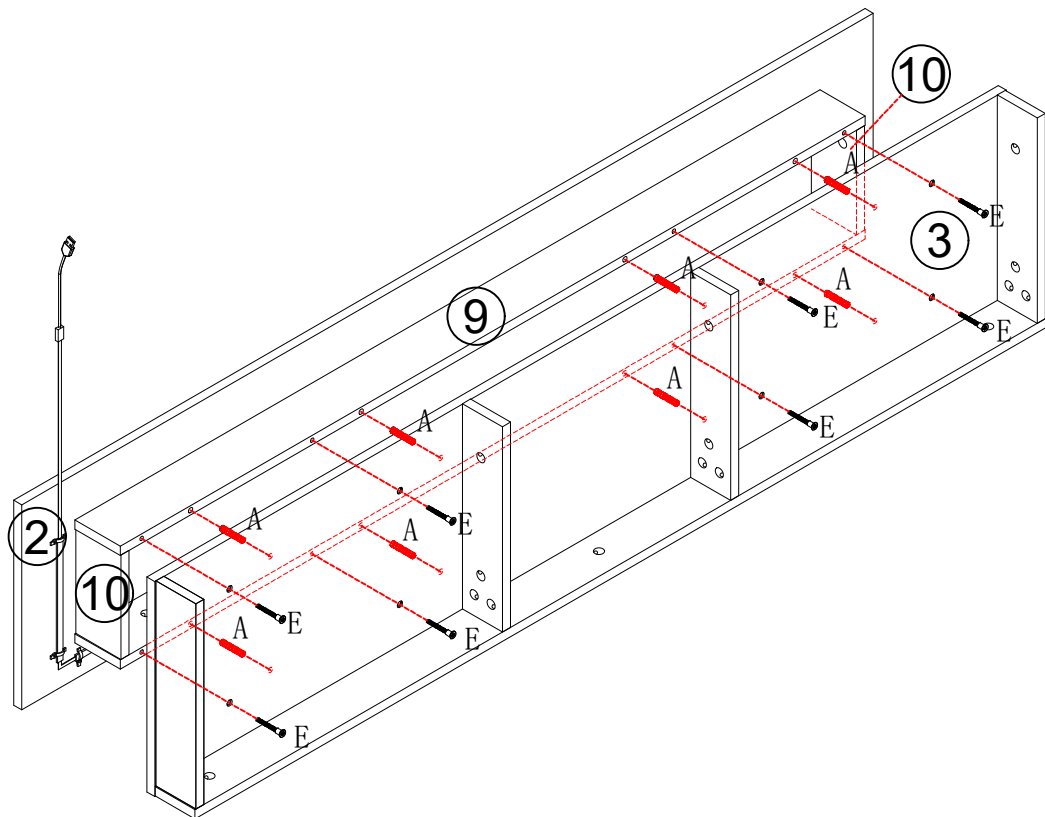
STEP 6



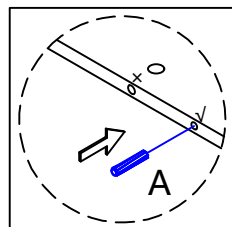

	Ax8pcs
	Ex8pcs

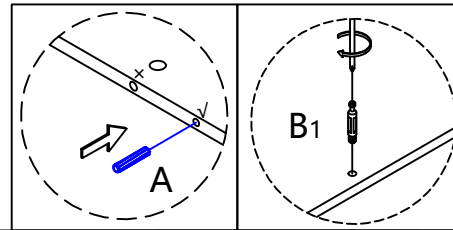
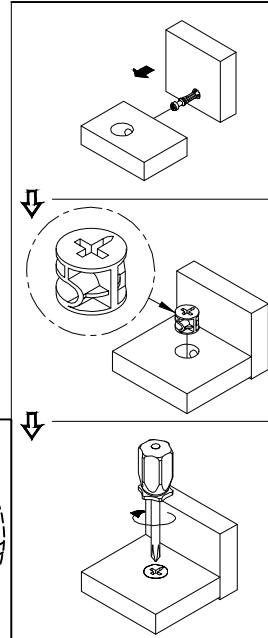
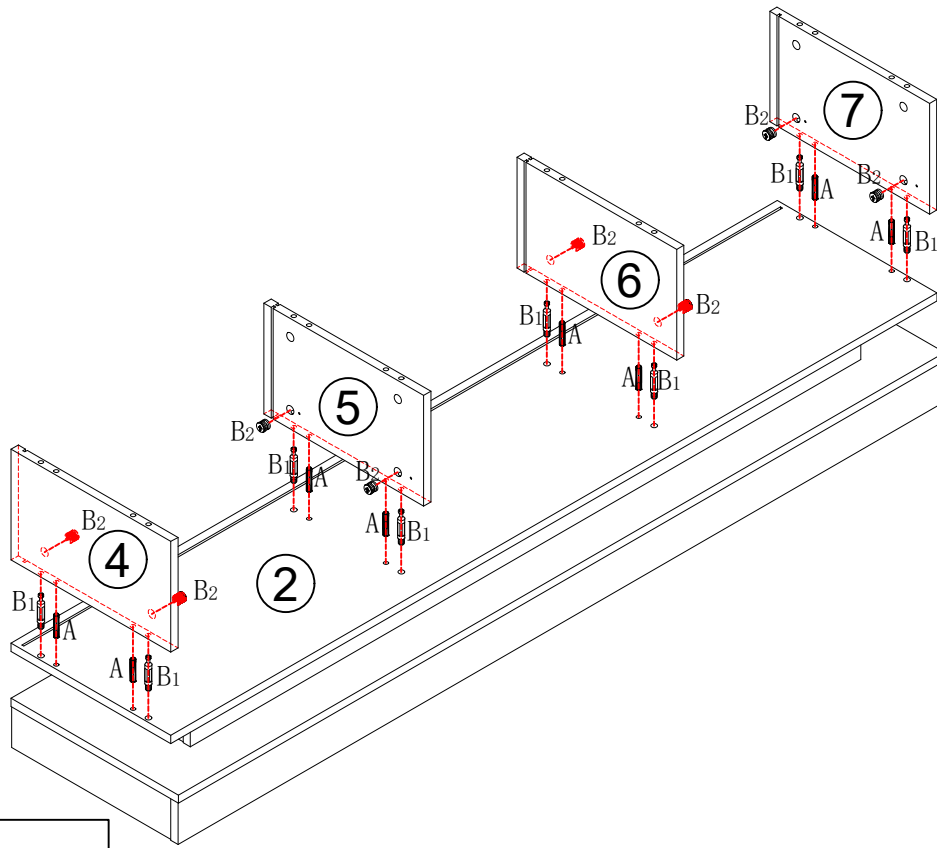

STEP 7





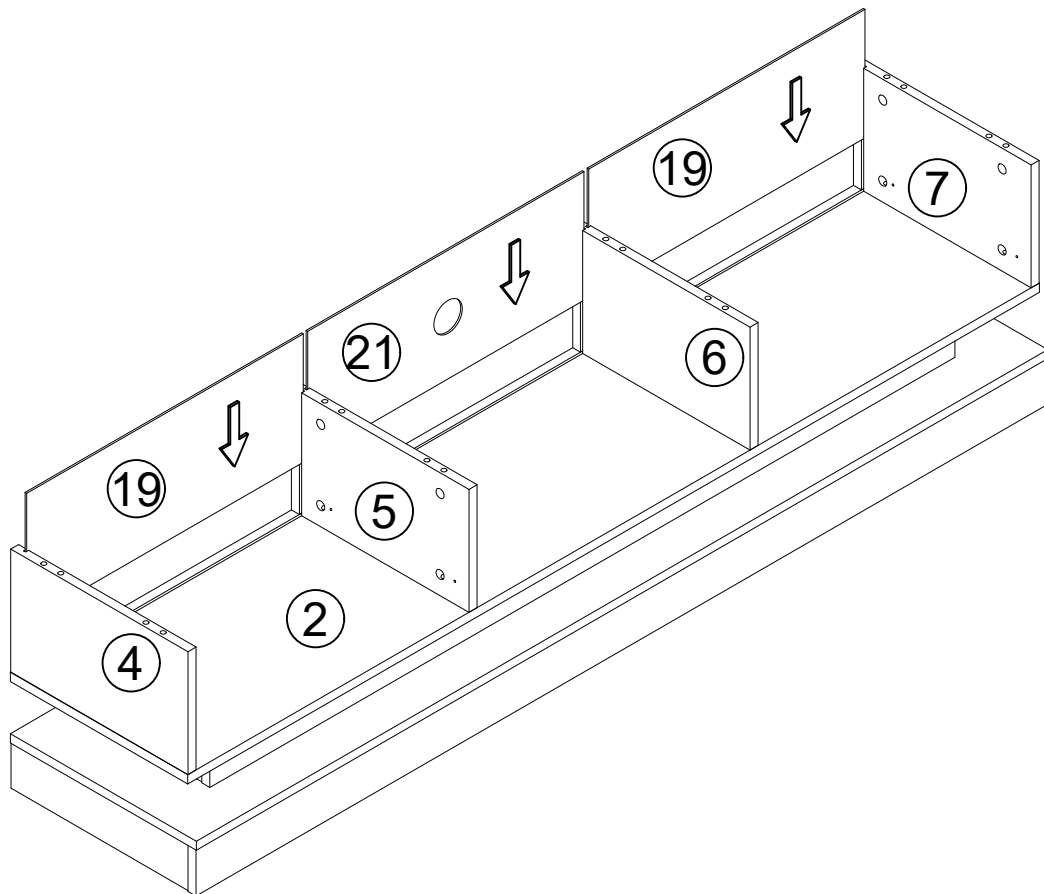

	Ax8pcs
	B ₁ x8pcs
	B ₂ x8pcs

STEP 8

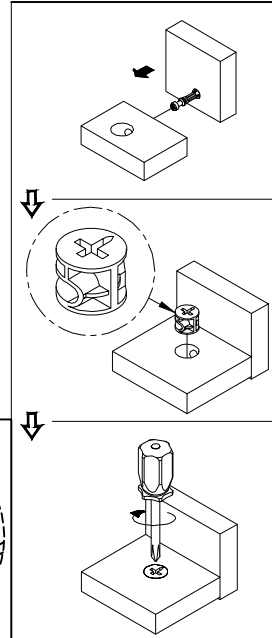
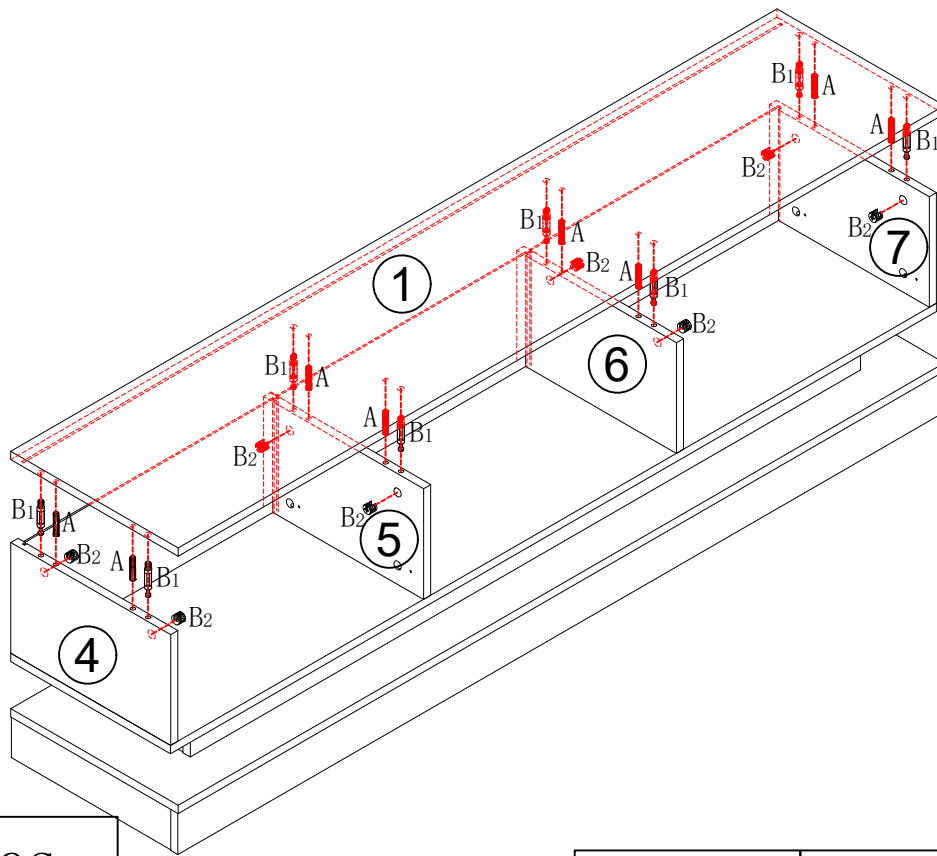

STEP 9



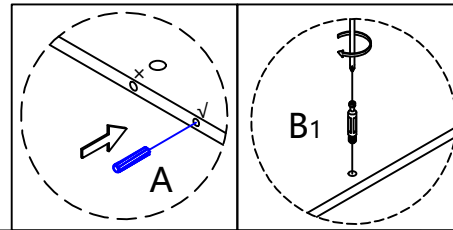

	Ax8pcs
	B ₁ x8pcs
	B ₂ x8pcs



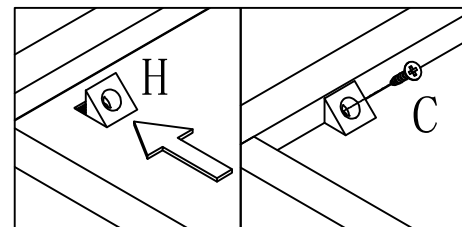
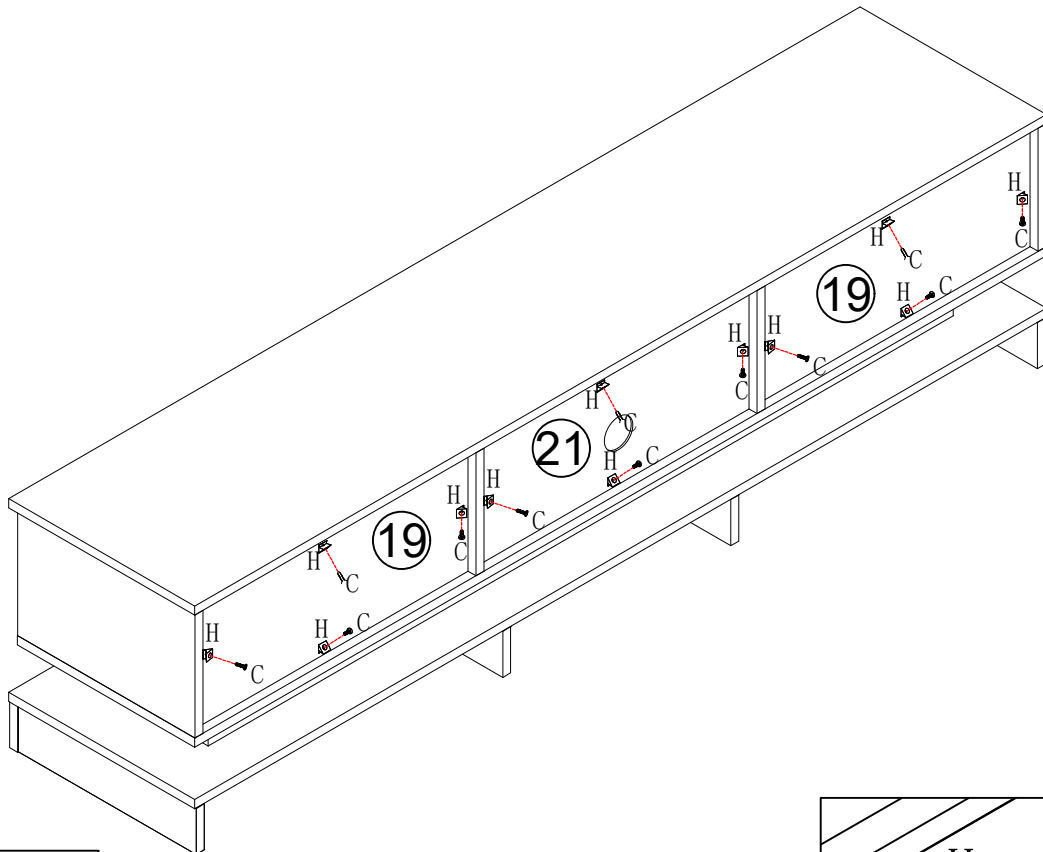



STEP 10

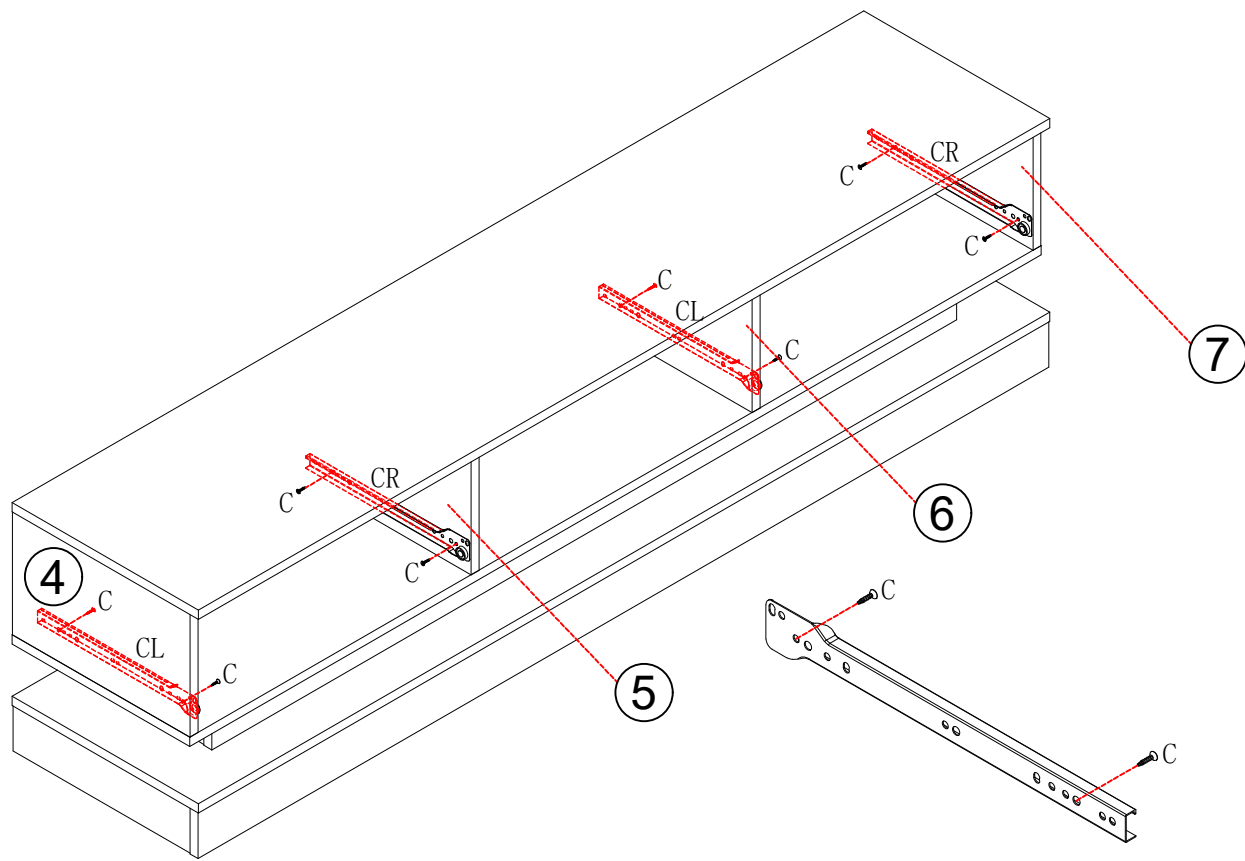

	Cx12pcs
	Hx12pcs

STEP 11



	Cx8pcs		
	CLx2pcs		CRx2pcs

STEP 12

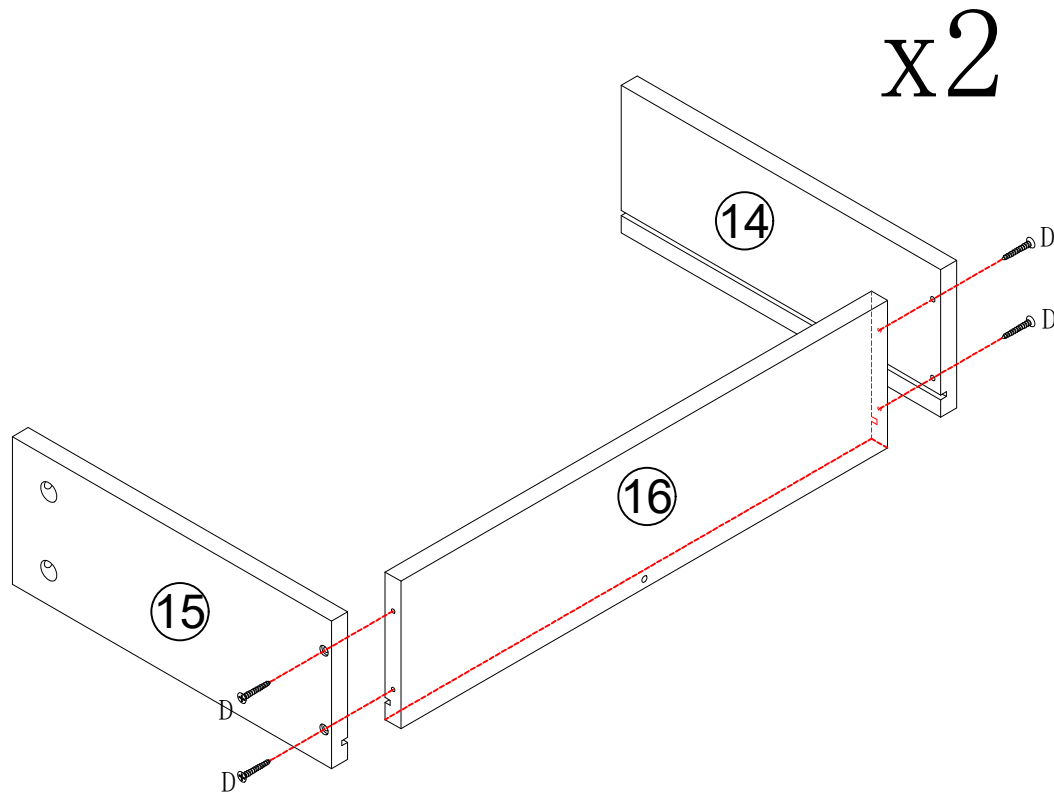

	Dx8pcs
--	--------

STEP 13

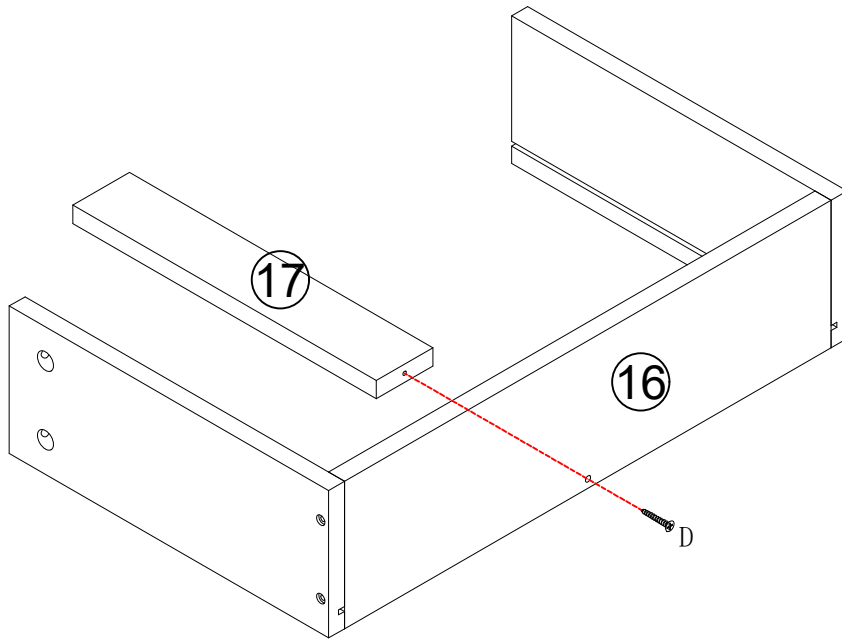

x2

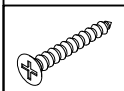

Dx2pcs

STEP 14

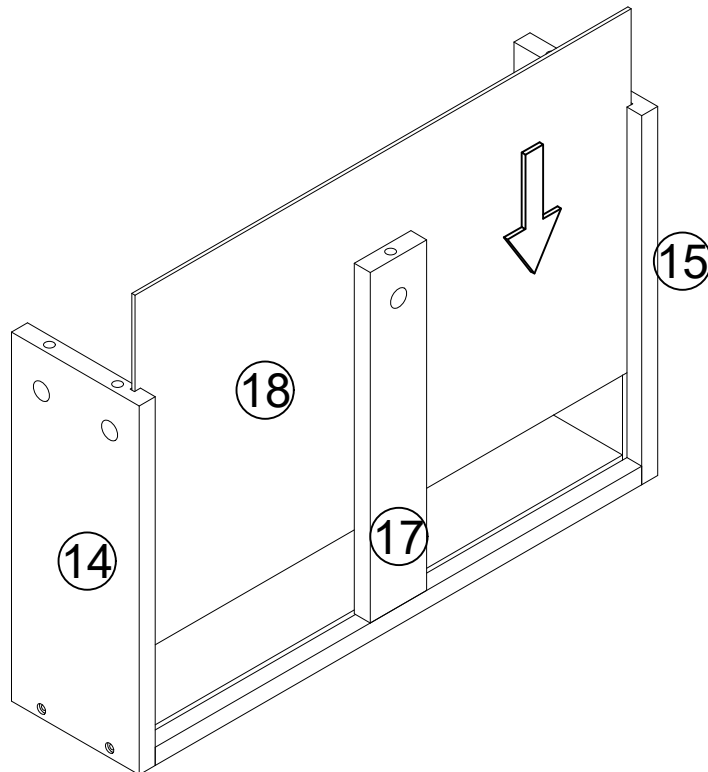

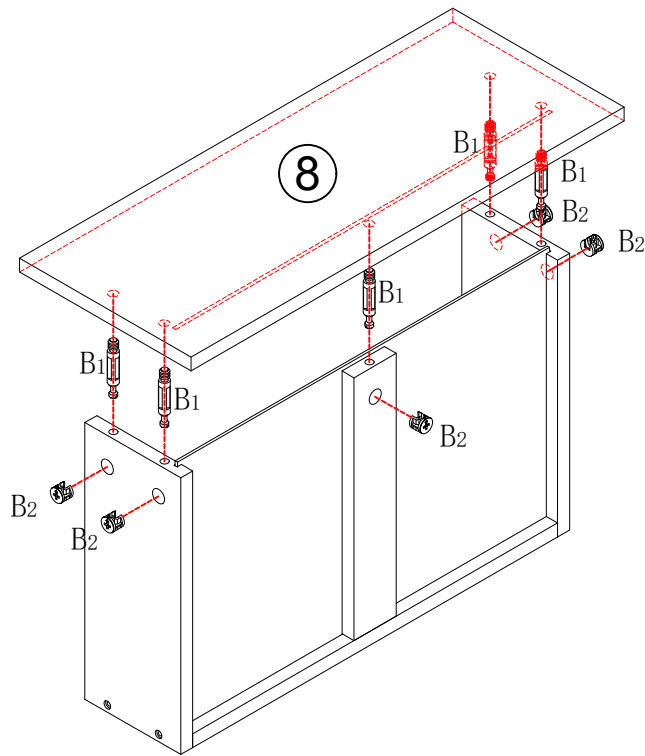

x2

STEP 15

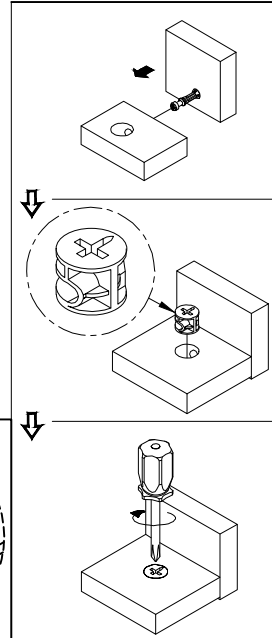

x2





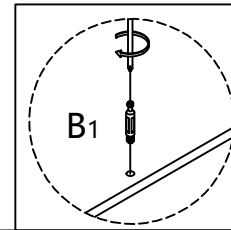

	B ₁ x10pcs
	B ₂ x10pcs

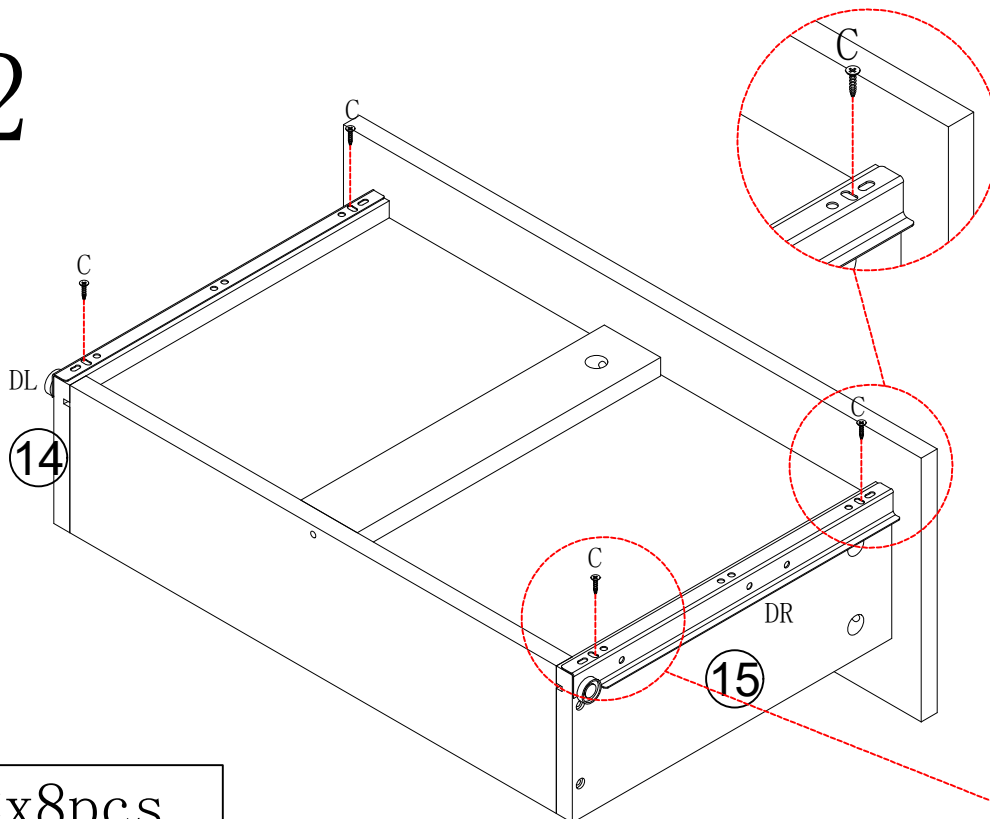

STEP 16

x2



	Cx8pcs
	DLx2pcs
	DRx2pcs

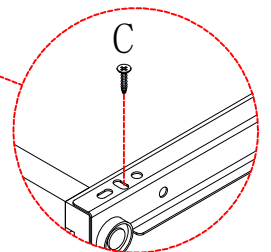



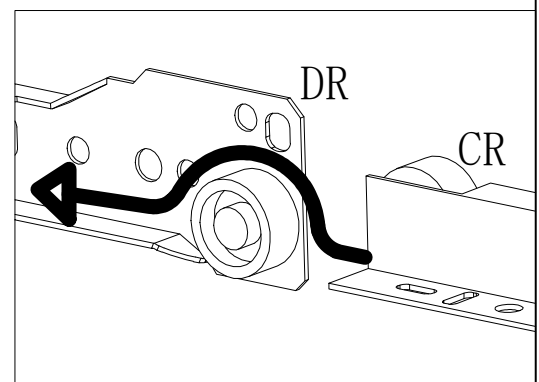
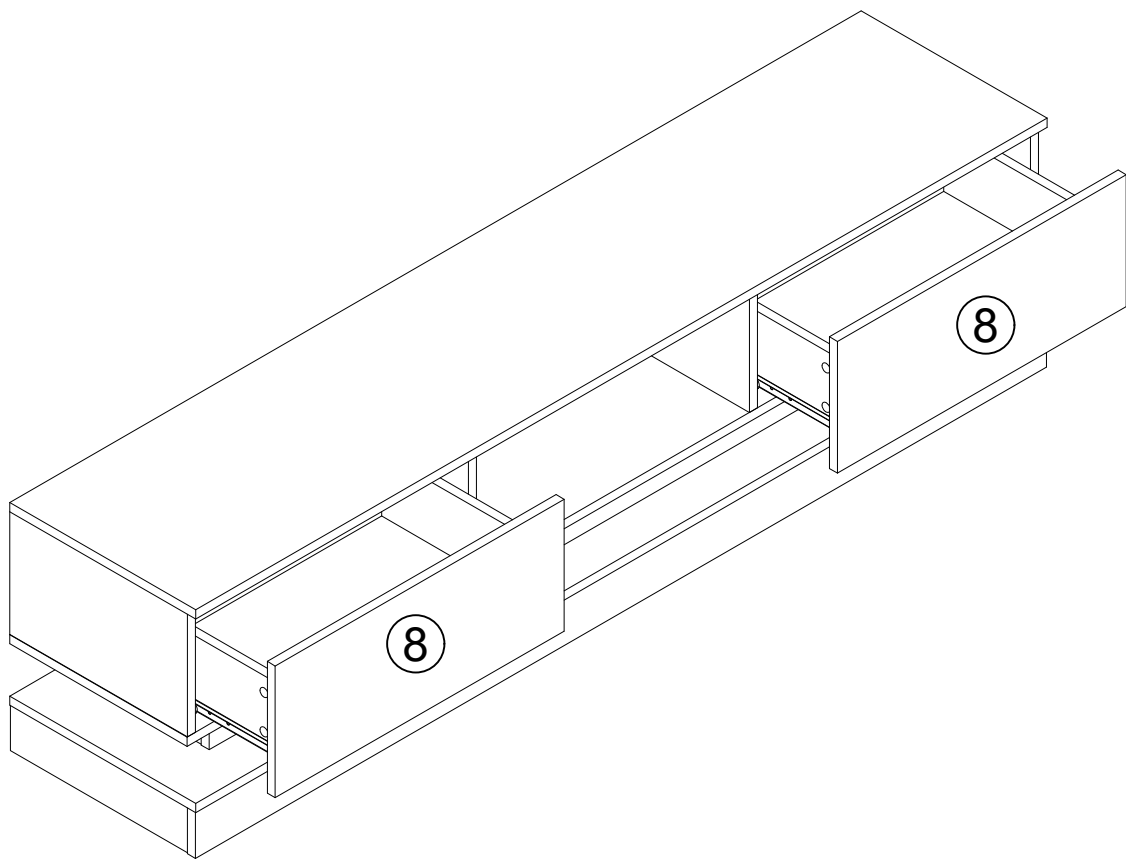

STEP 17

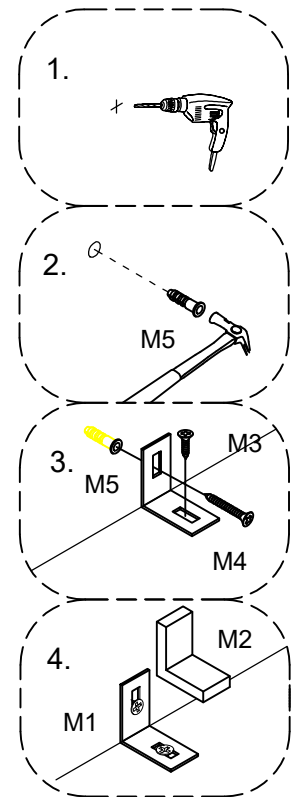
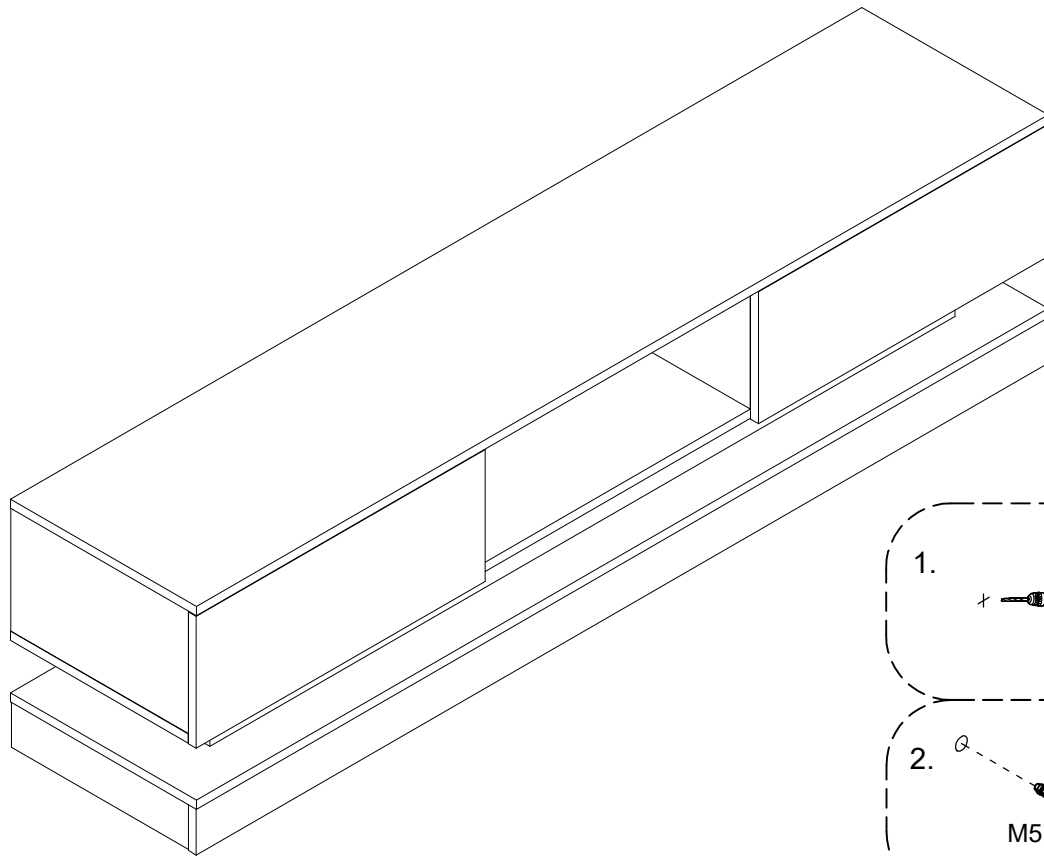

STEP 18



	M1x2pcs
	M2x2pcs
	M3x2pcs
	M4x2pcs
	M5x2pcs

STEP 19

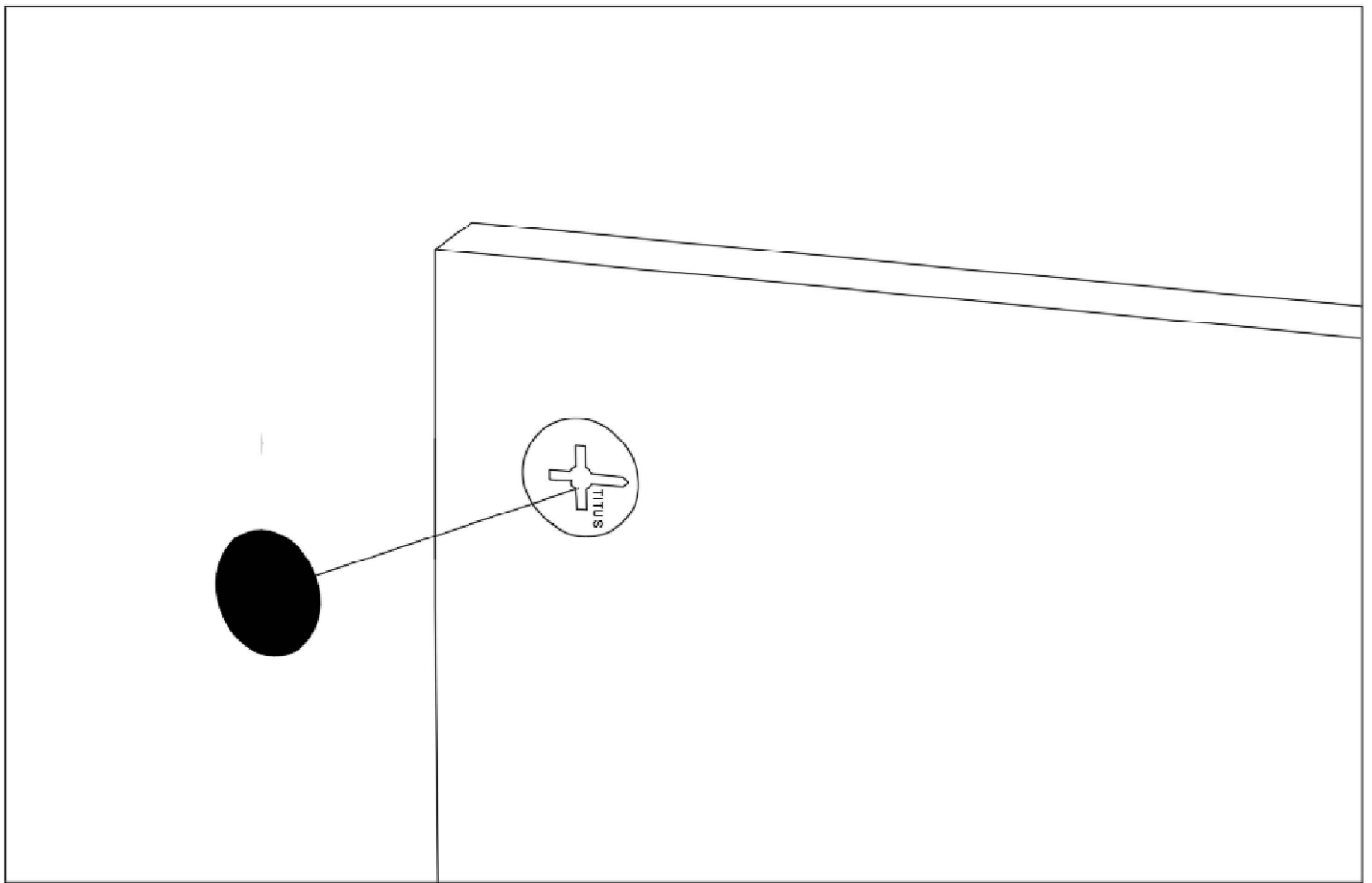

EN: After installing the product, stick the number Q on the perforated position

FR: Une fois le produit installé, collez le numéro Q à l'endroit où il y a des trous

DE: Nach der Installation des Produkts kleben Sie die Nummer Q auf die perforierte Position

IT:Dopo l'installazione del prodotto, fissare il numero Q sulla posizione perforata

ES:Después de instalar el producto, pegue el número Q en la posición perforada



Kx30pcs

Verification of Compliance

Verification No.:	TMC210319126-E
Name and address of Applicant:	Shenzhen CWG Technology Co., Ltd 5 / F, No.264 Baoshi East Road, Shiyan street, Bao'an District, Shenzhen,China 518108
Name and address of Manufacturer	Shenzhen CWG Technology Co., Ltd 5 / F, No.264 Baoshi East Road, Shiyan street, Bao'an District, Shenzhen,China 518108
Product name:	LED Strip
Rated:	DC12V
Product model(s):	CWG-5050RGB-60D-12V , additional models reference attachment
Product trademark:	创唯光

This verification confirms that the product meets the requirements of the following standard. The conformity was demonstrated based on following standard(s) listed by European Commission as harmonized with EMC Directive 2014/30/EU.

EN IEC 55015:2019+A11:2020
IEC 61547:2020

The verification has been carried out in accordance with individual rules and conditions agreed with the applicant. Evaluation has been carried out in accordance with:

Test report(s) No.:	TMC210319126-E
Test conducted by:	TMC Testing Services (Shenzhen) Co., Ltd.
Verification issue date:	March 26, 2021

Notes:

This verification refers to the above mentioned product and its conformity in regards of above mentioned standard(s) was proven on test sample.

This verification does not imply meeting all essential requirements, assessment of the series-production or any other restricted Notified Bodies conformity assessment procedure appropriate for the product.

This verification holder shall use this verification in connection to verification of conformity and technical data relevant for the product the verification was issued.

TMC Testing Services (Shenzhen) Co., Ltd.

t:86-755-86642861 cert@tmc-lab.com www.tmc-lab.com

1st Floor, Block A1, Zone A, Xinshidai Gongrong Industrial Park, No. 2, Shihuan Road, Shiyan Street, Baoan District, Shenzhen, China



Lab Director
Lemon Rao

