

# »1363«

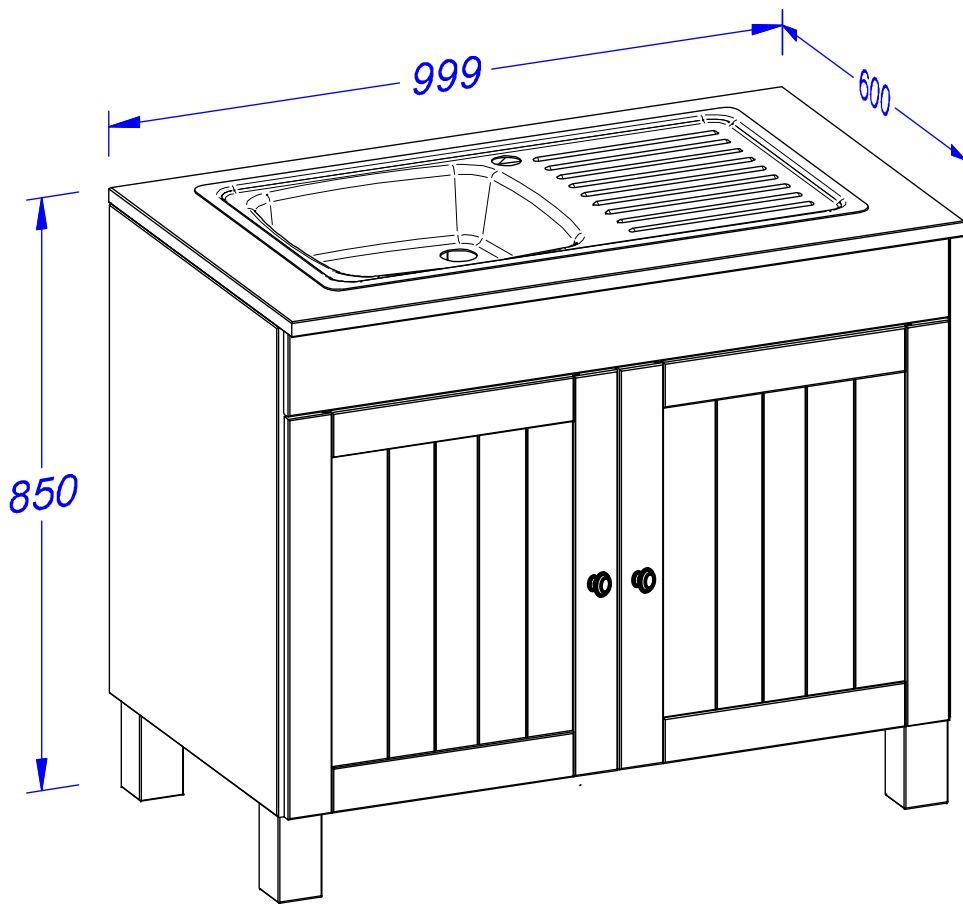

**(D)** *Montageanleitung*

**(NL)** *Handleiding voor de montage*

**(TR)** *Montaj talimatı*

**(FR)** *Notice de montage*

**(CZ)** *Montážní návod*

**(HU)** *Szerelési útmutató*

**(GB)** *Assembly instructions*

**(PL)** *Instrukcja montażu*

**(RU)** *Инструкция по монтажу*

**(IT)** *Istruzioni di montaggio*

**(SK)** *Návod na montáž*

**(RO)** *Instrucțiuni de montaj*









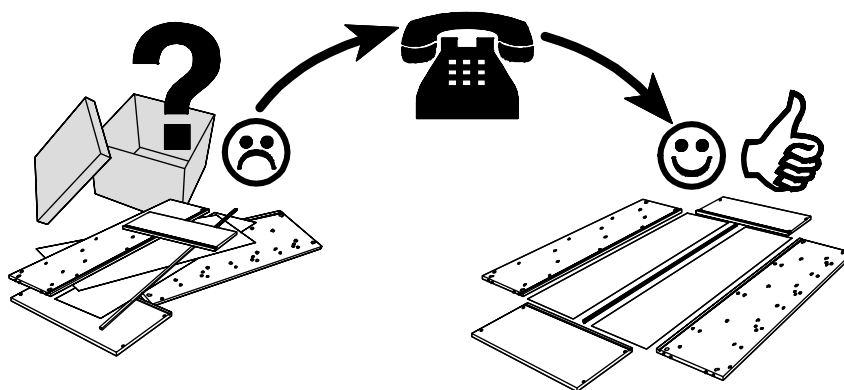
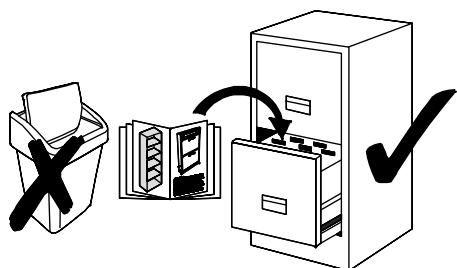

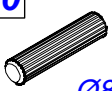
**Service • Dienstverlening • Serwis • Servis • Сервисная служба • Assistenza • Szerviz**

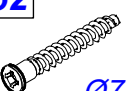
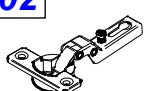
Name • Nom • Nome • Naam • Nazwa • Jméno •  
Názov • Név • Denumire • Isim • Название

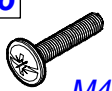
Nr. • No. • N° • Номер • Č • Sz

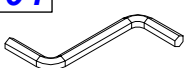
Typ • Type • Tip • Tipus • Тiпо • Тип

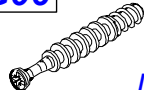
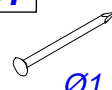

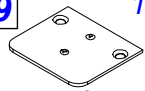

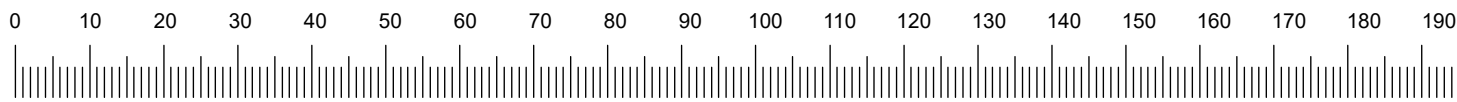
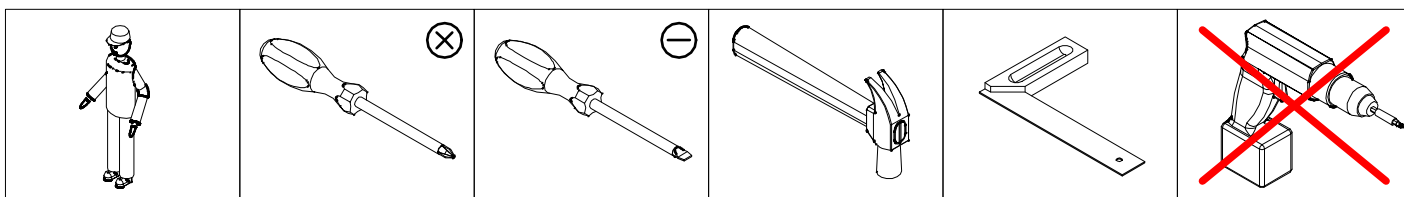

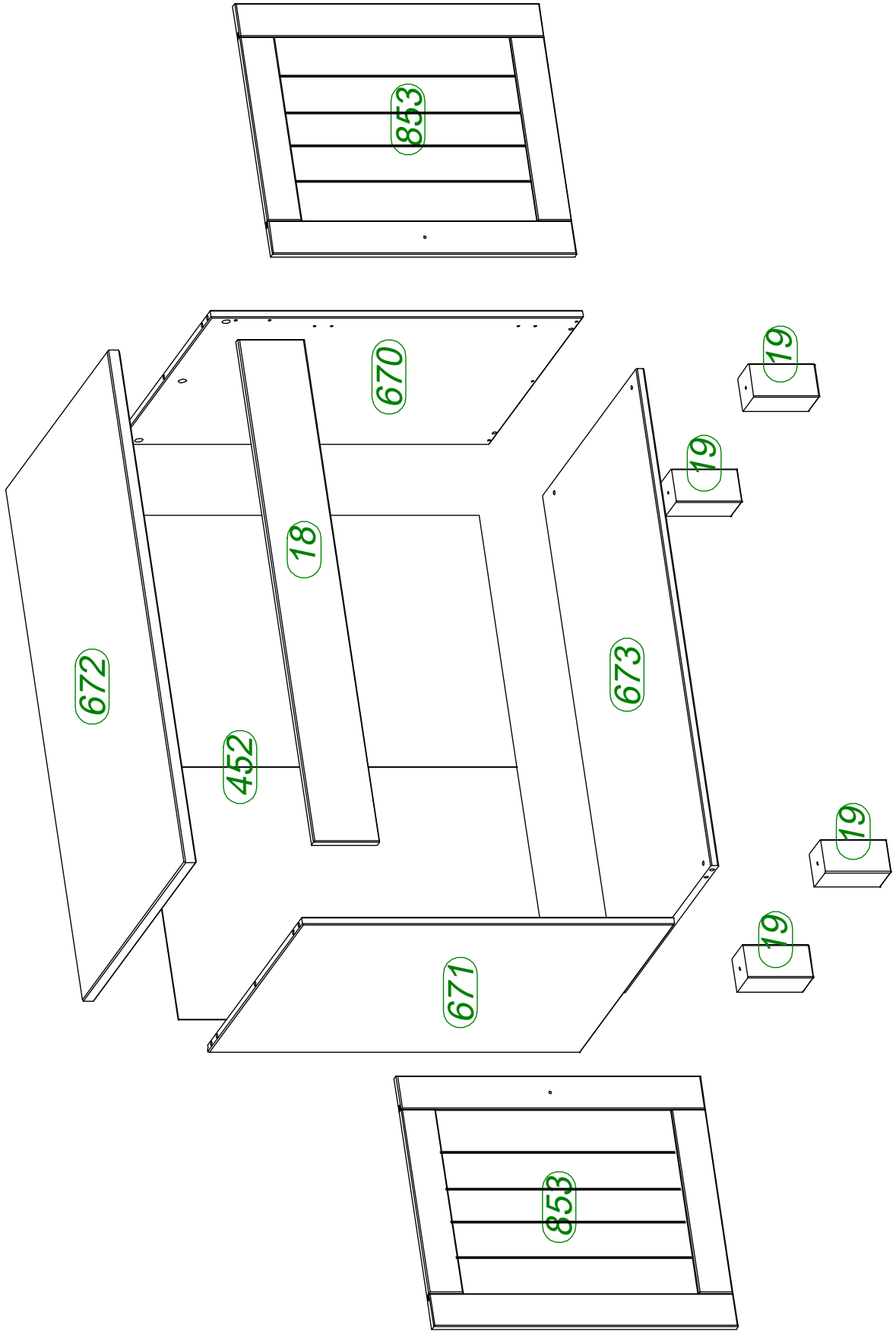
<b>A10</b> 8 x  Ø8 x 35	<b>B06</b> 8 x  Ø6,3 x 12	<b>B52</b> 4 x  Ø7 x 50	<b>C02</b> 4 x  fk.9	<b>C20</b> 4 x  2 mm	<b>D06</b> 2x  M4 x 20
<b>E17</b> 10 x  Ø3,5 x 15	<b>F04</b> 1 x  4 mm	<b>F08</b> 1 x  45 x 20 x 16	<b>G02</b> 12 x  Ø15 x 11	<b>G06</b> 12 x  L - 34	<b>I01</b> 50 x  Ø1,2 x 20
<b>K01</b> 4 x  20 x 20 x 16 / 6,5	<b>P23</b> 2 x  Ø30x21	<b>R19</b> 1 x  35 x 40			

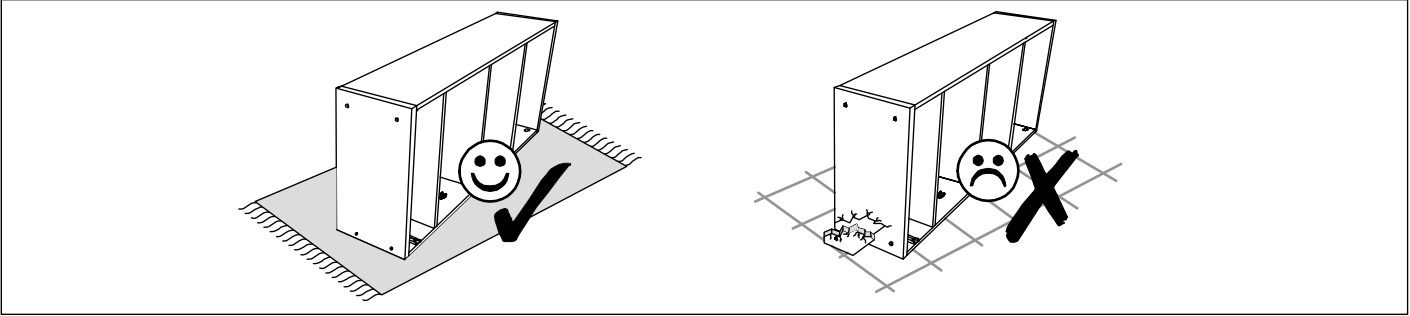



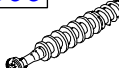

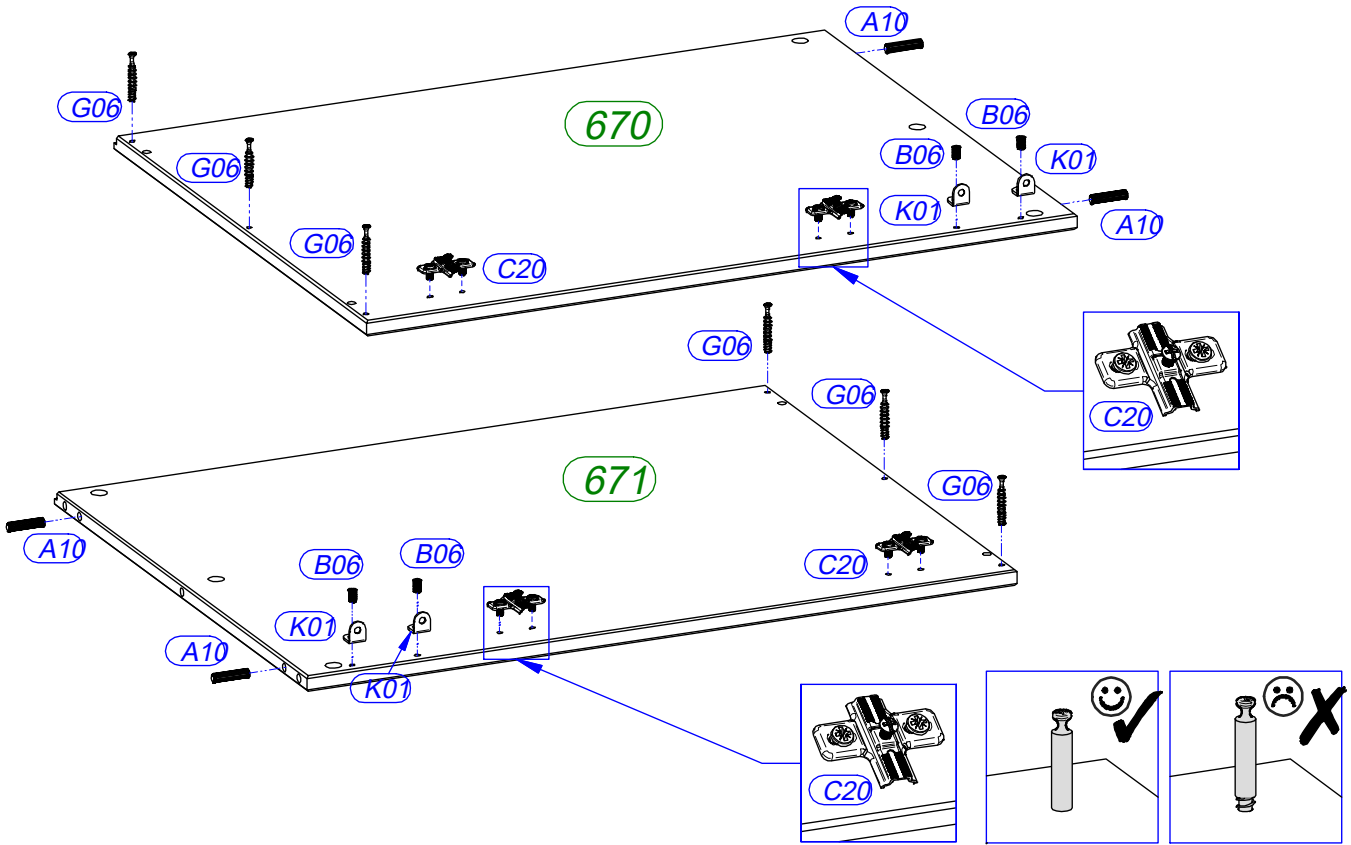

<b>A10</b>	4 x	<b>B06</b>	4 x	<b>C20</b>	4 x	<b>G06</b>	6 x	<b>K01</b>	4 x
									
$\varnothing 8 \times 35$		$\varnothing 6,3 \times 12$		2 mm		L - 34		20 x 20 x 16 / 6,5	



**1**

<b>A10</b>	4 x	<b>E17</b>	2 x	<b>R19</b>	1 x
					
$\varnothing 8 \times 35$		$\varnothing 3,5 \times 15$		35 x 40	

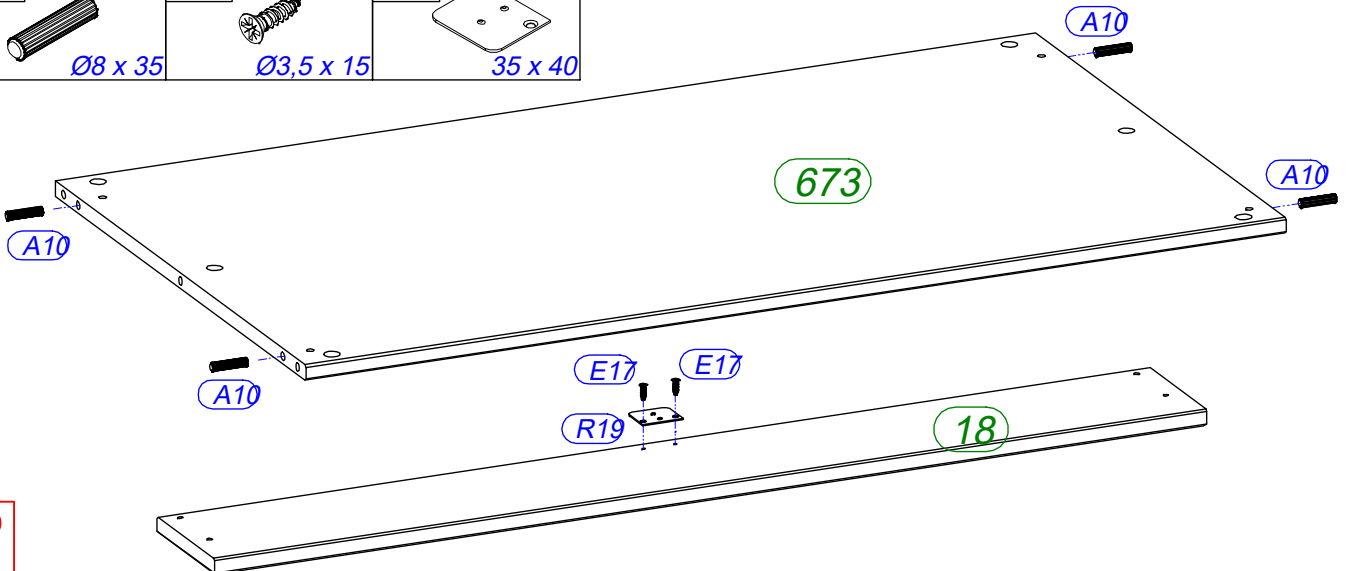

**2**

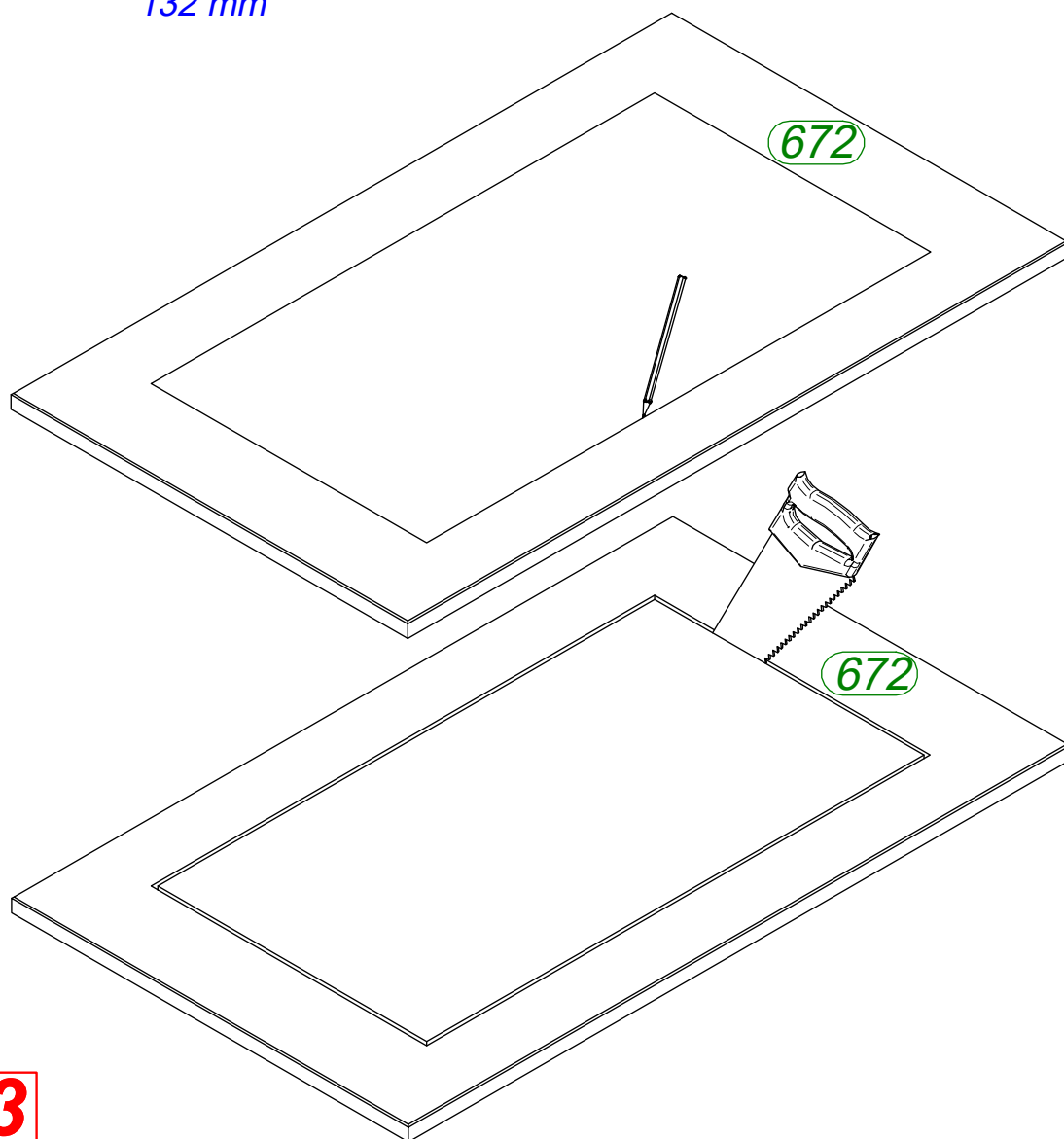
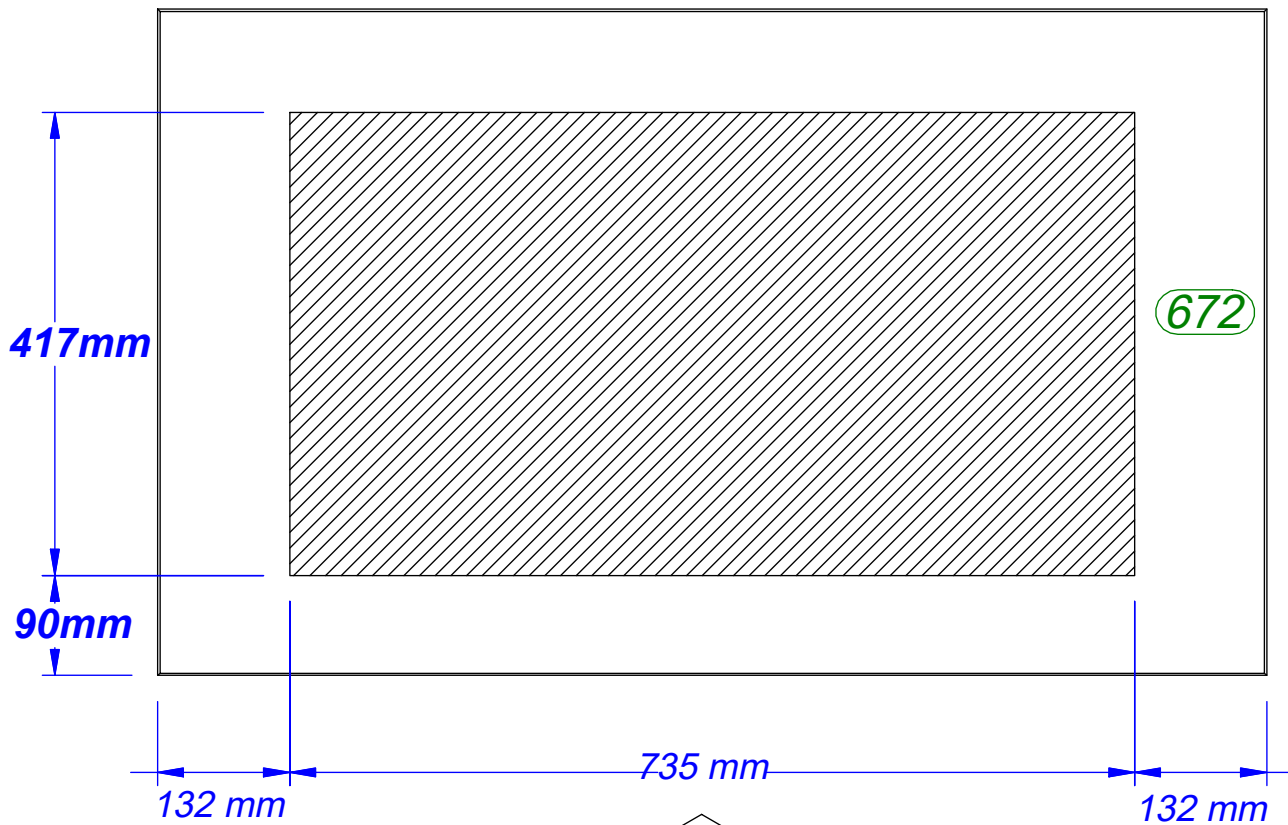

3

**Achtung • Attention • Attenzione • Opgelet • Uwaga • Pozor • Figyelem • Atenție • Dikkat • Вниманіе**

<b>(D)</b>	Bitte montieren Sie das Spülbecken auf der Topplatte laut Aufbauanleitung des Spülbeckens als erstes.
<b>(GB)</b>	Please mount the basin onto the top plate first, as described in the manual.
<b>(NL)</b>	Plaats de bak eerst op de bovenste plaat zoals beschreven in de handleiding.
<b>(PL)</b>	W pierwszej kolejności zamontować zlewozmywak na górnym blacie zgodnie z instrukcją montażu zlewozmywaka.
<b>(TR)</b>	İlk önce, kullanım kılavuzunda tanımlandığı üzere evyenin en üst tabaka üzerinde kurulumunu gerçekleştirin.
<b>(RU)</b>	Сначала установите резервуар на верхнюю плиту как описано в руководстве.
<b>(FR)</b>	S'il vous plaît installer le bassin sur la plaque du haut d'abord, comme décrit dans le manuel.
<b>(IT)</b>	Si prega di montare il bacino sulla piastra superiore, come descritto nel manuale.
<b>(CZ)</b>	Prosím, držák pánve na horní desce první, jak je popsáno v manuálu.
<b>(SK)</b>	Prosím, držiak panvice na hornej doske prvé, ako je popísané v manuáli.
<b>(HU)</b>	Kérjük, szerelje fel a medencét rá a felső lemez első, ahogy az a kézikönyvben.
<b>(RO)</b>	Vă rugăm să mount bazinul pe placa de top în primul rând, așa cum este descris în manual.

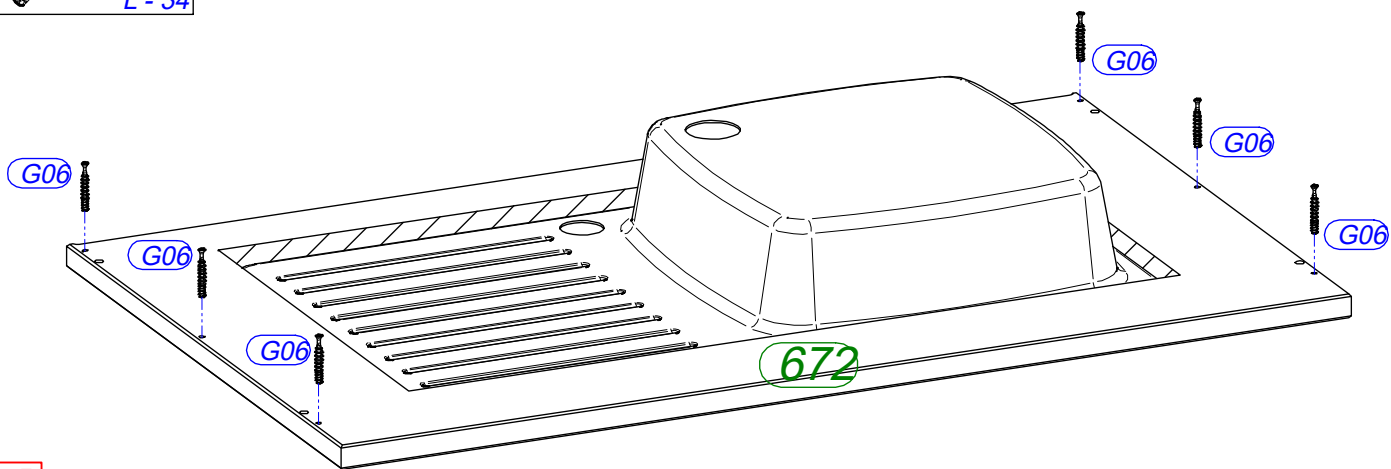
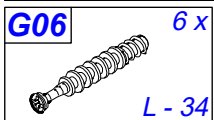

**4**

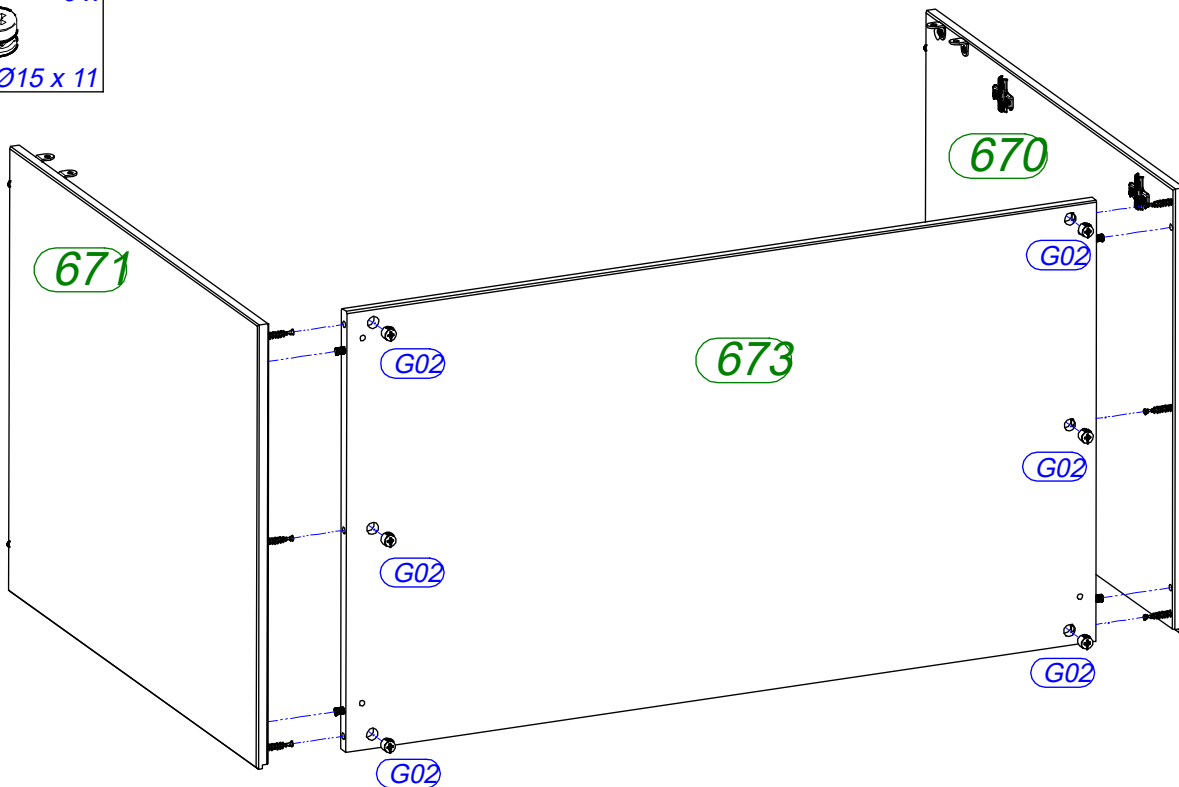
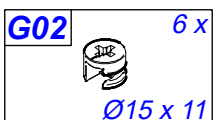

**5**

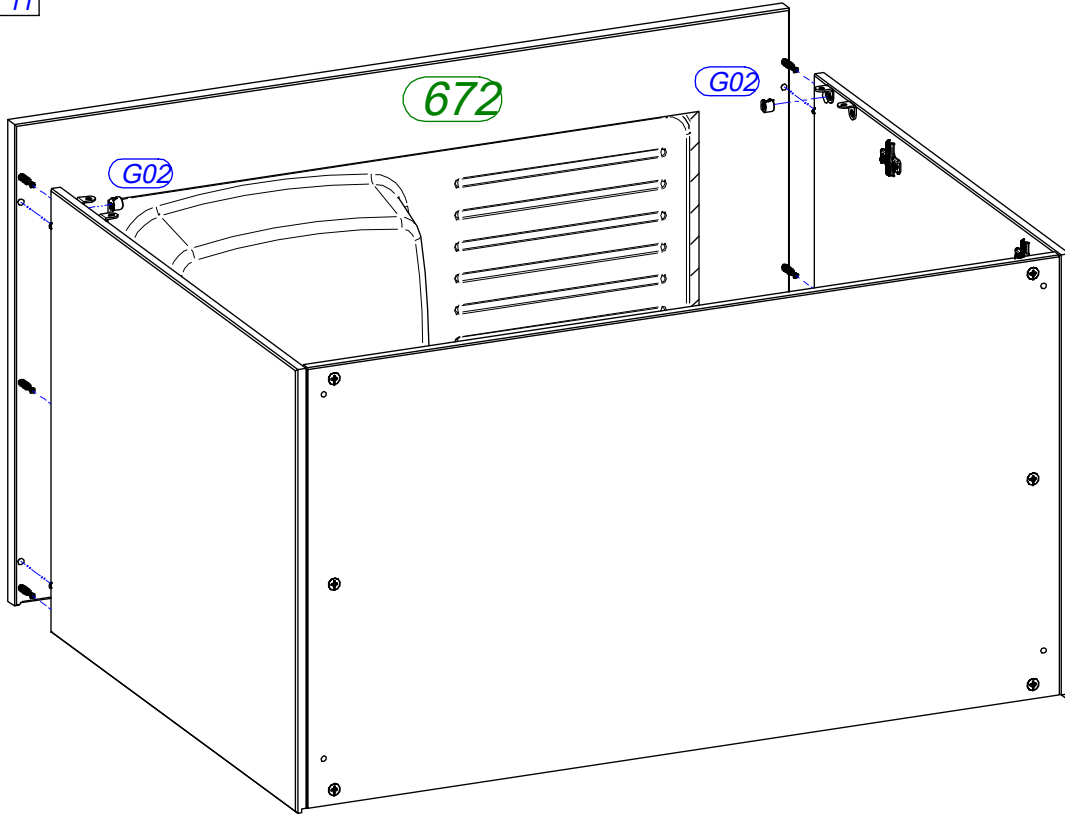
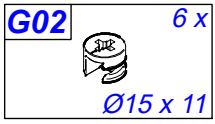

**6**

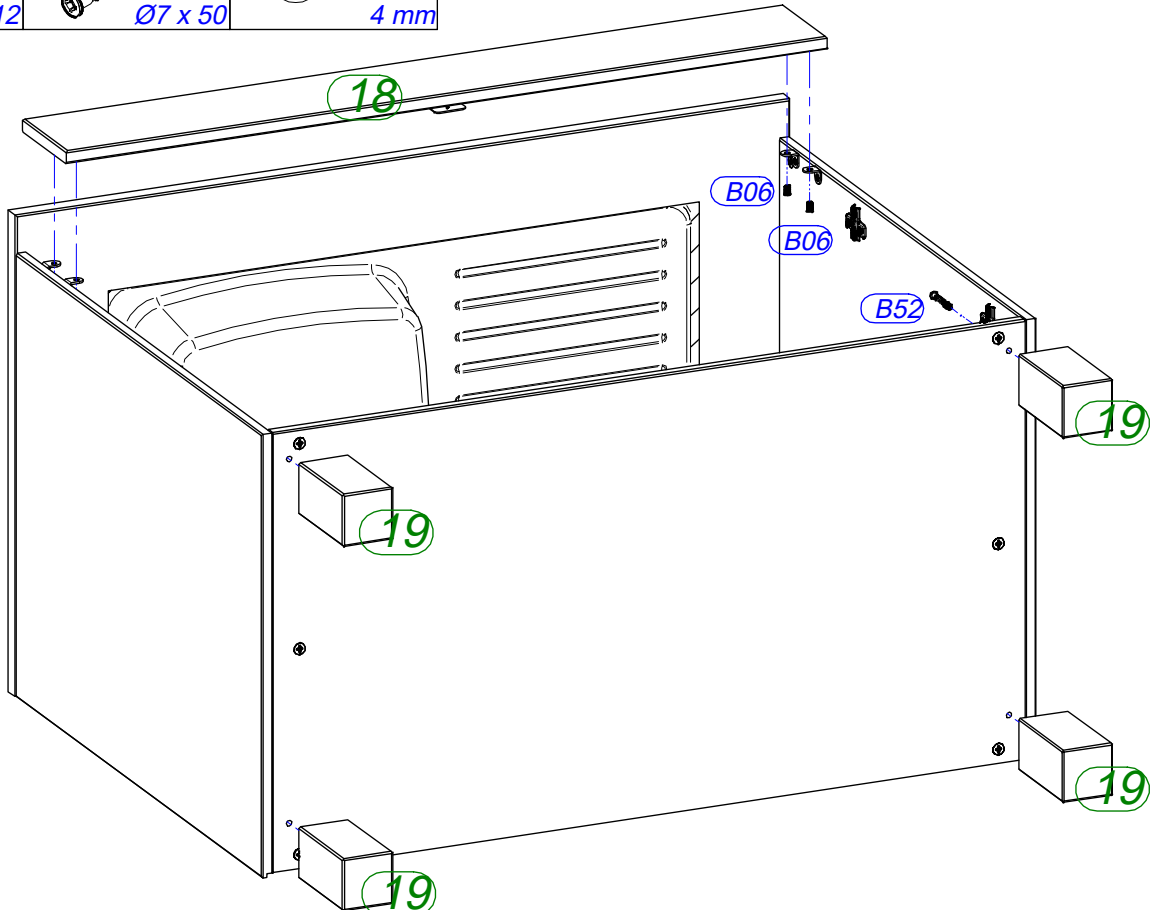
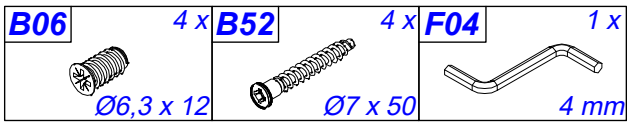

**7**

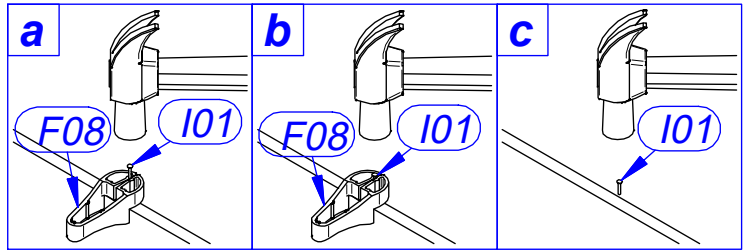
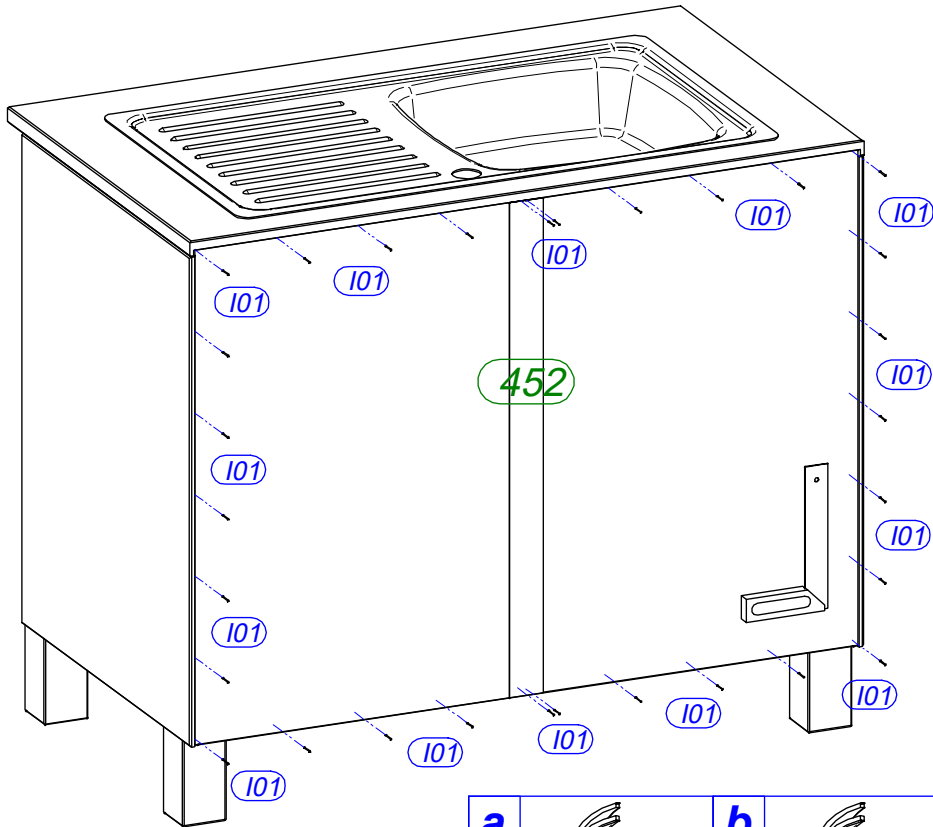
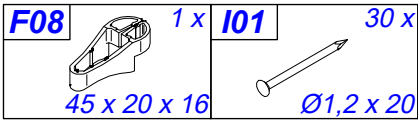

**8**

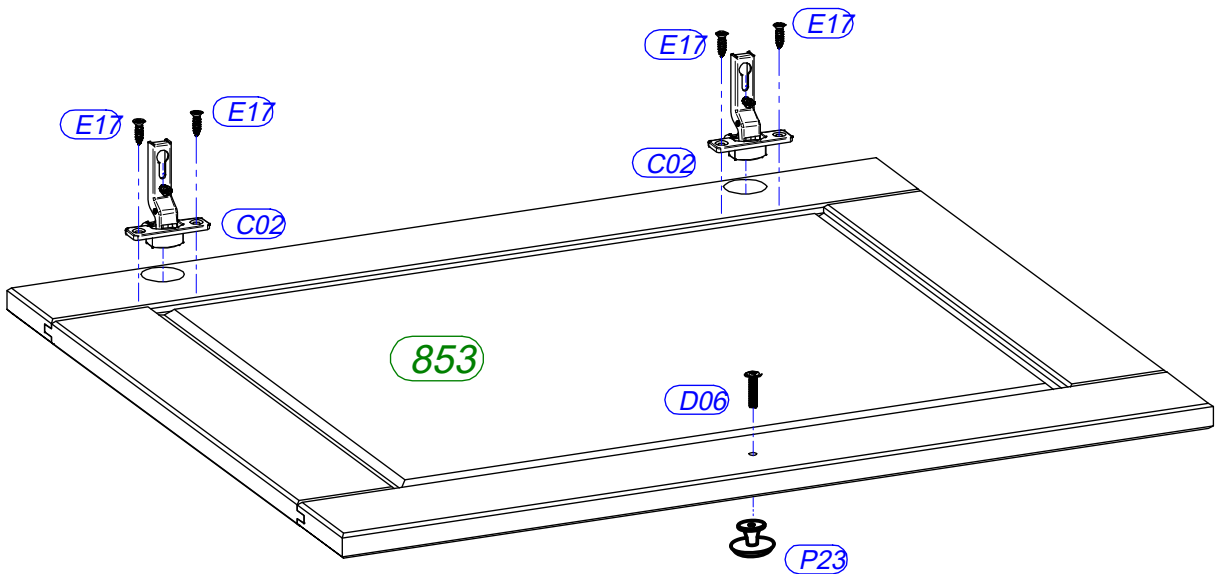
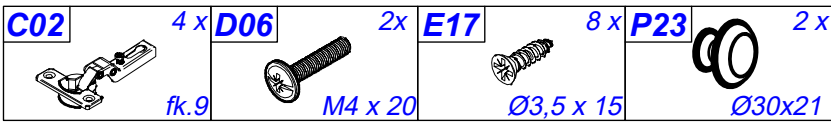

**9x 2**



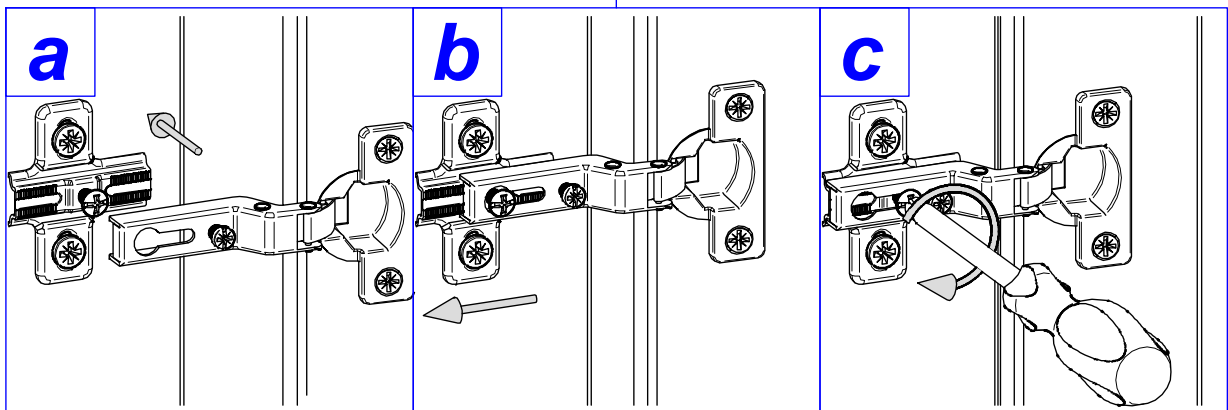
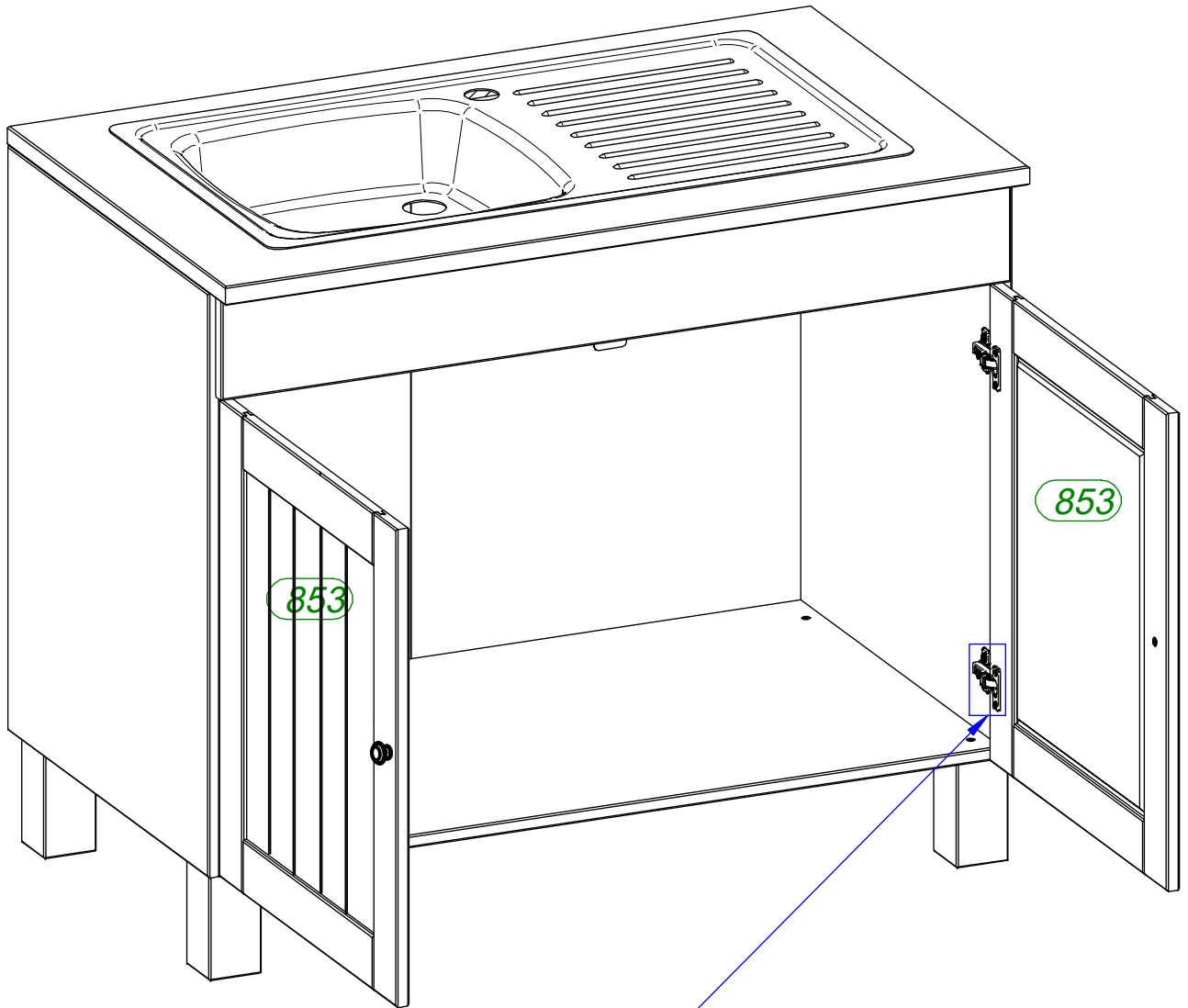

10

**! Achtung • Attention • Attenzione • Opgelet • Uwaga • Pozor • Figyelem • Atenție • Dikkat • Внимание !**

<b>(D)</b>	Türen einstellen (Scharniere justieren)
<b>(GB)</b>	Adjusting the doors (adjusting the hinges)
<b>(NL)</b>	Deuren instellen (scharnieren afstellen)
<b>(PL)</b>	Nastawić drzwi (wyrównać zawiasy)
<b>(TR)</b>	Kapıların ayarlanması (menteşelerin seviye ayarı)
<b>(RU)</b>	Регулировка дверей (регулировка шарнира)
<b>(FR)</b>	Régler les portes (ajuster les charnières)
<b>(IT)</b>	Sistemare le porte (regolare le cerniere)
<b>(CZ)</b>	Vyrovnejte dvířka (seřídte závěsy)
<b>(SK)</b>	Nastavenie dverí (nastavenie závesov)
<b>(HU)</b>	Állítsa be az ajtókat (állítsa be a zsanérokot)
<b>(RO)</b>	Reglare ușii (ajustare balamale)

