

Montageanleitung Assembly instructions Instructions de montage Instrucciones de montaje Istruzioni per il montaggio Инструкция для монтажа Instrukcja montażu Montážní návod Návod na montáž Szerelési utasítás Инструкция за монтаж Kurulum Talimatları Navodilo za montažo Montagehandleiding A s e n n u s o h j e Upute o montaži

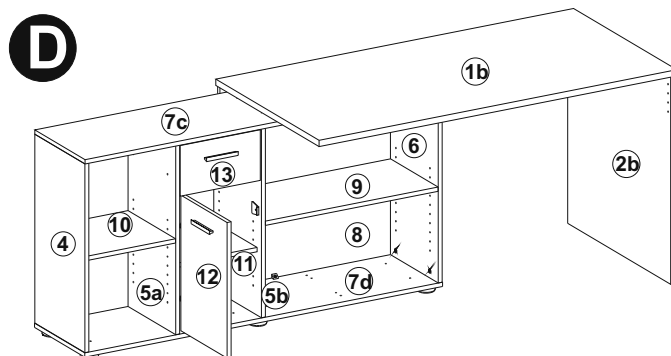
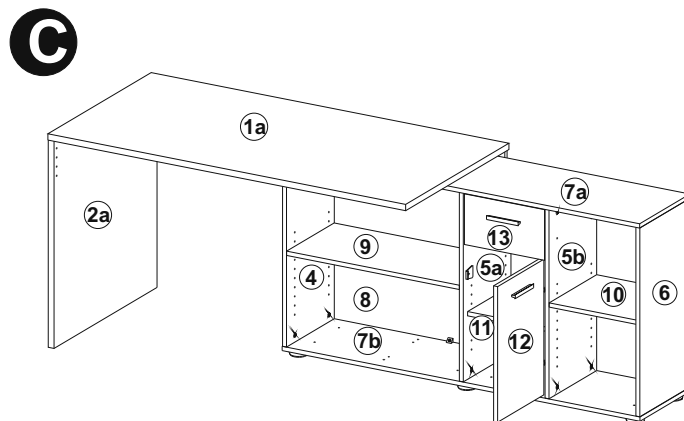
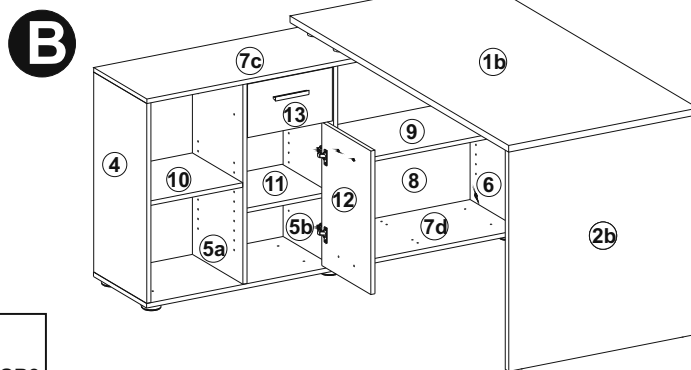
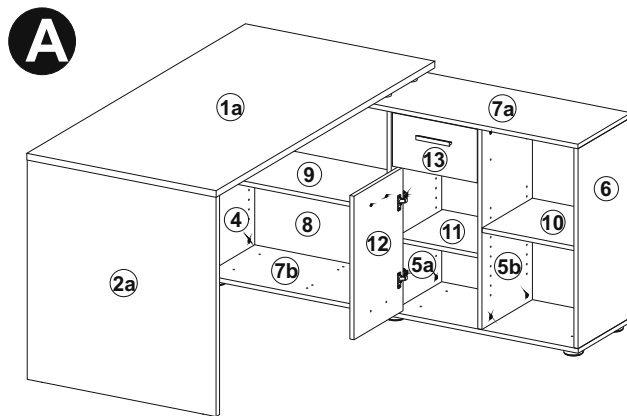
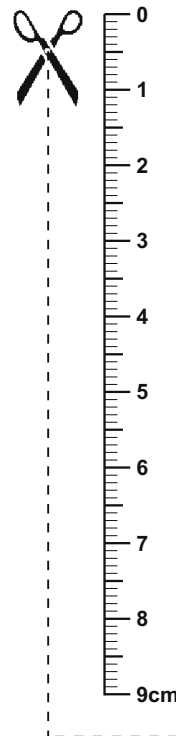

Beschläge / fittings / Ferrures pour meubles / Herrajes / Guarnizioni / Железные оправы для мебели / Okucia / Kovány / Kovanie / Vasalások / обков / Parçaları / okovje / Hang- en sluitwerk / helat / Obloge

10 x GI25	3,5x22 2 x SP10	6 x ZB 4	3,5x20 6 x SP3
3 x VB 6	18 x VB1	21 x VB14	2 x TB8
280 2 x SK4	5,8x11 4 x SO1	8,0x35 4 x VB18	M4x8 2 x SG1
5,0x35 18 x VB4	2 x GL7	4x25 2 x SP11	4 x AK1
12 x BT1	2 x TB19	3,5x15 4 x SP1	16 x AK2
2 x GR18	3,5x25 4 x SR1	1 x WI 3	
1 x ZB1	2,7x20 6 x SR2	4,0x45 4 x SR8	3,0x12 1 x SP7
2 x VB5	1 x Wi3	4,0x13 2 x SO14	

Sie benötigen:
 You need:
 Vous avez besoin de:
 Necesita:
 Le servono :
 Вам нужно:
 Potrebujete:
 Tarvitset:

Potrzebne są:
 Potřebujete:
 Potrebujete:
 Szükséges eszközök:
 На Вас са Ви нужны:
 Ihtiyaciniz:
 U hebt nodig:
 Trebate:

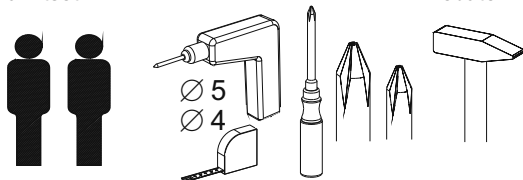



DE

Bitte die Montageanleitung vor Beginn sorgfältig studieren. Um eine ordnungsgemäße und mangelfreie Erstellung zu gewährleisten muss die Montage exakt in der gezeigten Reihenfolge ausgeführt werden. Wir empfehlen die Montage nur durch Fachkundiges Personal.

GB

Please carefully read through the assembly instructions before starting. To ensure proper, fault-free construction, assembly is to be carried out exactly as shown in the sequence. We recommend having the assembly done only by qualified personnel.

FR

Lire scrupuleusement les instructions de montage avant de commencer le montage. Afin de garantir une construction conforme et irréprochable, le montage doit être effectué exactement dans l'ordre indiqué. Nous recommandons de ne faire effectuer le montage que par du personnel qualifié.

ES

Antes de empezar lea detenidamente las instrucciones de montaje. Para garantizar una construcción adecuada y sin defectos, el montaje deberá llevarse a cabo en el orden exacto que se indica. Le recomendamos que el montaje lo efectúe únicamente personal especializado.

CZ

Prostudujte, prosím, před začátkem práce pečlivě Montážní návod. Aby bylo zaručeno žádné a bezchybné sestavení, musí se montáž provést přesně v uvedeném pořadí. Doporučujeme, aby montáž prováděl v dané oblasti odborník.

SK

Pred započatím práce si prosíme starostlivo prečítať návod na montáž. Aby bolo možné zaručiť správne a bezchybné zostavenie, je nutné pri montáži dodržiavať presne vyznačený postup. Odporúčame, nechá urobiť montáž odborníkom.

HU

Kezddel tén gondosan tanulmányozza a szerelési utasítást! Az szabályszer és hibátlan elkészítés garantálása érdekében a szerelést pontosan amint mutatott sorrendben kell elvégezni. Javasoljuk, hogy csak szakképzett személyzet végezze el a szerelést.

PL

Przed rozpoczęciem montażu proszę uważnie zapoznać się ze stosowną instrukcją. Aby zapewnić prawidłowe przeprowadzenie montażu należy wykonywać wszystkie czynności dokładnie wg przedstawionej kolejności. Polecamy montaż wyłącznie przez fachowy personel.

RU

Перед началом внимательно изучить инструкцию по монтажу, чтобы гарантировать надлежащую и безошибочную компоновку, монтаж должен выполняться точно в показанной последовательности. Мы рекомендуем монтаж только силами компетентного персонала.

SI

Pred začetkom, prosimo, navodilo za montažo skrbno tudirajte. Za zagotovitev redne in nepomanjkljive izdelave se mora montaža izvesti natančno v prikazanem vrstnem redu.

IT

Per favore prima dell'inizio studiare accuratamente le istruzioni per il montaggio. Per garantire una realizzazione senza errori, il montaggio deve essere fatto rispettando esattamente la sequenza indicata. Consigliamo di far eseguire il montaggio esclusivamente da parte di personale esperto.

BG

Преди монтажа внимателно разучете инструкцията. Монтажът задължително трябва да се извърши в посочената последователност, за да отговаря на изискванията и да бъде

TR

безупречен. Ие препоручваме монтажта да се извършва от квалифициран персонал.

HR

Lütfen kurulum talimatlar başlangıçta dikkatle iyice inceleyiniz. Doğru ve hatasız üretim sağlamak için, montaj gösterilen sıradaya tam olarak yapılmalıdır. Biz montajı sadece yetkin personel tarafından öneririz.

IT

Molimo Vas da upute omontaži prije početka pažljivo pročitate. Kako bi se zajamila pravilna i besprijekorna izrada, montaža se mora izvesti točno po prikazanom redoslijedu. Preporuku ujedno

NL/BL

Bestudeer de montagehandleiding a.u.b. zorgvuldig alvorens te beginnen. Om een volledig correcte en vlekkeloze opstelling te garanderen, moet demontage precies in de getoonde volgorde worden uitgevoerd. Wij raden aan om de montage alleen door vakkundig personeel te laten uitvoeren.

RO

Înainte de a începe, citiți cu atenție instrucțiunile de montaj. Pentru a se asigura un montaj corect și fără defecte, acesta trebuie realizat exact în ordinea indicată. Recomandăm ca montarea să fie făcută doar de personal calificat.

DK

Husk at læse monteringsvejledningen grundigt, inden du begynder. Arbejdsstrinnene skal udføres i den viste rækkefølge for at sikre, at resultatet bliver helt rigtigt. Vi anbefaler, at du lader monteringsarbejdet udføres af en fagmand.

PT

Estudar as instruções de montagem antes do início. Para garantir uma constituição correcta e sem falhas, a montagem tem que ser efectuada exactamente na sequência indicada. Recomendamos que a montagem seja efectuada apenas por pessoal técnico especializado.

SE

Ötuda monteringsanvisningen noga innan du börjar att montera. För att garantera ett korrekt och felfritt uppförande, måste monteringen ske exakt och i den anvisade ordningsföljden. Vi rekommenderar att endast låta sakkunnig personal utföra monteringen.



DE

Entsorgen Sie die Verpackungen bzw. das Produkt nach Abnutzung Umweltgerecht.

GB

Please dispose of the packaging and of an old product no longer in use without any danger to the environment.

FR

Veuillez vous débarrasser de l'emballage ou du produit après son utilisation selon les conditions sur l'environnement.

ES

Desechar por favor el embalaje o producto ateniéndose a las normas ecológicas vigentes una vez que éste se haya desgastado.

CZ

Po použití likvidujte obal nebo výrobek ekologicky.

SK

Obal resp. produkt po opotrebení zlikvidujte ekologicky.

HU

Kérjük, hogy a csomagolást, illetve a terméket elhasználódás után környezetkímélő módon takarítsa el.

PL

Produkt po zużyciu i jego opakowanie utylizować w ekologiczny sposób.

- RU** У паковку и изделие после амортизации утилизируйте в соответствии с экологическими требованиями.
- SI** Poskrbite za okolju prijazno odstranitev embalaže oz. produkta po uporabi
- IT** Non disperdere nell'ambiente e provvedere ad uno smaltimento ecologico dopol'uso.
- BG** И зхвърляйте опаковката респ. вече негодния продукт според изискванията за апа зване на околната среда.
- TR** Ambalaj ve ürünü kullanımdan sonra çevreye zarar vermeden yok edin.
- HR** Odstranite pakovanje odnosno proizvod nakon upotrebe ekološki.
- NL/BL** Voer de verpakking resp. het product na gebruik op milieuvriendelijke wijze af.
- RO** Îlimina i ambalajul, respectiv produsul după de s-a uzat, fără a afecta mediul înconjurător.
- DK** Forpackningsaffald respektive produktet skal fjernes miljørigtigt.
- PT** Elimine a embalagem ou o produto observando as normas ecológicas vigentes depois do seu desgaste.
- SE** Avfall från förpackning respektive produktet skall utföras miljökorrekt .

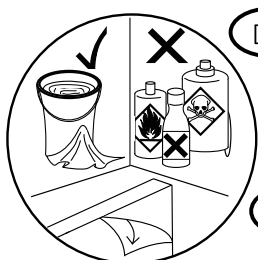

- DE** Pflegehinweis! Bitte nur mit einem Staubtuch oder einem feuchten Lappen reinigen. Keine scheuernden Mittel, Säure, Lösungsmittel, Spiritus, Azeton etc. verwenden. Vor montage von Hochglanzfronten die Schutzfolie entfernen.
- GB** Care instructions! Please do only clean with a duster or a damp cloth. Do not use abrasive cleaning agents, acids, solvents, methylated spirits, or acetone etc.! Remove the protective foil before inserting the high-gloss front panels.
- FR** Indications d'entretien ! Ne nettoyer qu'avec un chiffon poussièrè ou un chiffon humide. Ne pas utiliser de produits agressifs ni d'acides, de solvants, d'alcool, d'acétone, etc. Retirer le film protecteur avant le montage des façades brillantes.
- ES** Indicaciones de mantenimiento! Limpiar sólo con un trapo para el polvo o con un trapo húmedo. No deben utilizarse medios abrasivos, ácido, disolventes, alcohol, acetona, etc. Antes del montaje de frentes de alto brillo, retirar la lámina de protección.
- CZ** Pokyny pro ošetřování! Iste te, prosím, pouze prachovkou nebo vlhkým hadrem. Ním mýdlovým roztokem nepouívat žádné abrazivní čistící prost edky, kyseliny, ředidla, líh, aceton atd. Před montáží čel s vysokým leskem odstraňte ochrannou fólii.
- SK** Pokyn k údržbe! Prosíme utiera len prachovkou alebo vlhkou handri kou. Ným mydlovým roztokom, nepouívajte žiadne agresívne prostriedky, kyseliny, riedidlá, lieh, acetón a pod. Pred montážou odstráňte ochrannú fóliu z vysokolesklých čel.
- HU** Ápolási útmutatás! Kérjük, hogycsak portör! kendővel vagy nedves ronggyal tisztítsa! Os szappanos víz oldattal tisztítsa. Ne használjon súrolószereket, savakat, oldószereket, alkoholt, acetont, stb. A magas fényezésű frontelemek beszerelése előtt a védőfóliát el kell távolítani.
- PL** Pielgnacja! Czy cié tylko przy pomocy suchej lub wilgotnej ściereczki. Nie wolno stosować jakichkolwiek środków ściernych, kwasów, rozpuszczalników, spirytusu, acetonu itp.! Przed montażem frontów na wysoki połysk należy zdjąć folię ochronną.
- RU** Указание по уходу! росьба чистить только тряпкой для пыли или влажной тряпкой. ни в коем случае не применять абразивные чистящие средства, кислоту, растворители, спирт, ацетон и т.п. Перед установкой снять защитную пленку с лицевых полированных сторон.
- SI** Navodilo za nego! Iстите, prosimo, le s krpo za prah ali z vlažno krpo. Ne uporabljajte sredstev za drgnjenje, kisline, topil, pira, acetona itd. Pred namestitvijo visoko-sijajne prednje strani odstranite zaščitno folijo.
- IT** Istruzione di cura! Per favore pulire solo con un panno per rimuovere polvere o con uno straccio umido. Non utilizzare prodotti abrasivi, acidi, soluzioni, spirito, acetone, ecc.! Prima del montaggio, rimuovere la pellicola protettiva dalle parti anteriori ad alta lucentezza.
- BG** Указание за поддръжка! очиствайте само с кърпа за прах или влажен парцал. не използвайте абразивни препарати, киселина, разтворител, спирт, ацетон и т.н.! Преди монтаж на фасади с огледален блясък отстранете защитното фолио.
- TR** Bak m talimatları! Lütfen sadece bir toz bezi ya da nemli bir bezle temizleyiniz. Aşındırıcı maddeler, asitler, çözücüler, alkol, aseton vb kullanmayın! Montajdan önce yüksek parlak cephelerden koruyucu folyoyu çıkarın.
- HR** Uputa o njegovanju! Istiti samo jednom maramom za pra inu ili jednom vla nom krpom. Ne koristite abrazivna sredstva, kiseline, otapala, benzin, aceton i slično. Prije montaže otklonite zaštitnu foliju od visoko sjajne prednjice.
- NL/BL** Onderhoudsinformatie! A.u.b. alleen reinigen met een stofdoek of een vochtige lap. Geen schurende reinigingsmiddelen, zuren, oplosmiddelen, alcohol, aceton, etc. gebruiken! Voor montage van hoogglansfronten de beschermfolie verwijderen.
- RO** Îndica ie privind întreținerea! Rug ma se cură a doar cu o cârp de ters prafulsau cu o lavet umedă. Nu utiliza i agenți abrazivi, acizi, solvenți, spirt, aceton etc. Înainte de montarea fronturilor foarte lucioase, îndepărtați folia de protecție.
- DK** Pleje! Rengöring foretages med en støvklud eller en fugtig klud. Brug ingen skurende midler, syre, opløsningsmidler, spiritus, azetone etc. Fjern beskyttelsesfolien inden montering af højglansfronter.
- PT** Indicação de tratamento! Limpar apenas com um pano suave ou humedecido. Não usar produtos abrasivos, ácidos, solventes, álcool etílico, acetona, etc. Antes da montagem das frentes de briho intenso remover a película de proteção.
- SE** Skötselanvisning! Rengör antingen med torr dammtrasa eller med en fuktig trasa. inga skurmedel, syror, sprit, lösningsmedel, aceton osv. får användas. Avlägsna skyddsfilmerna från höglansfronterna före montering.

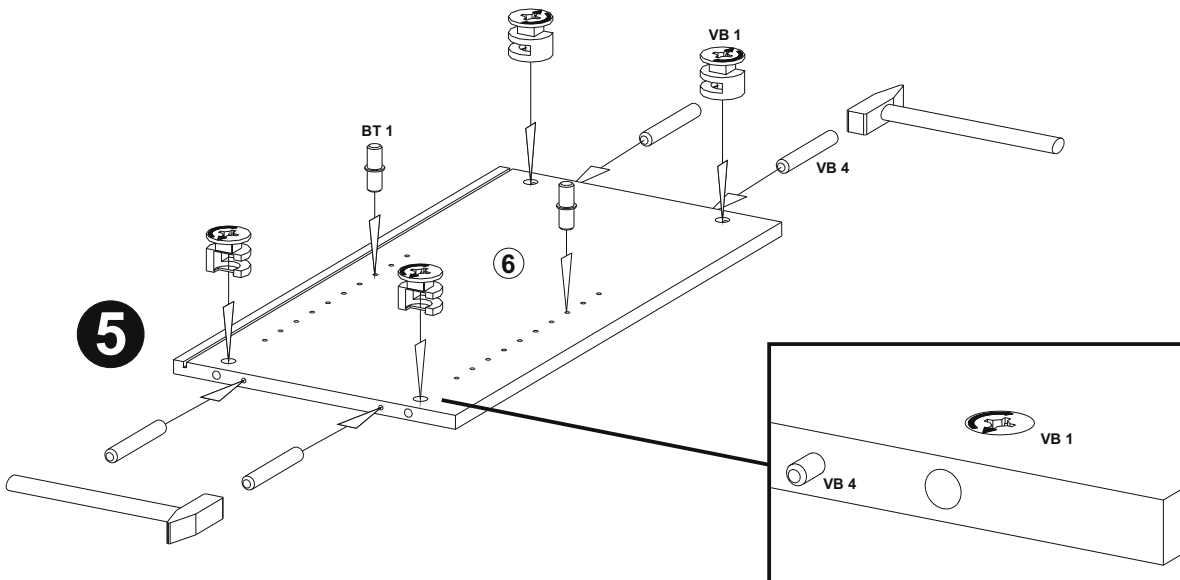
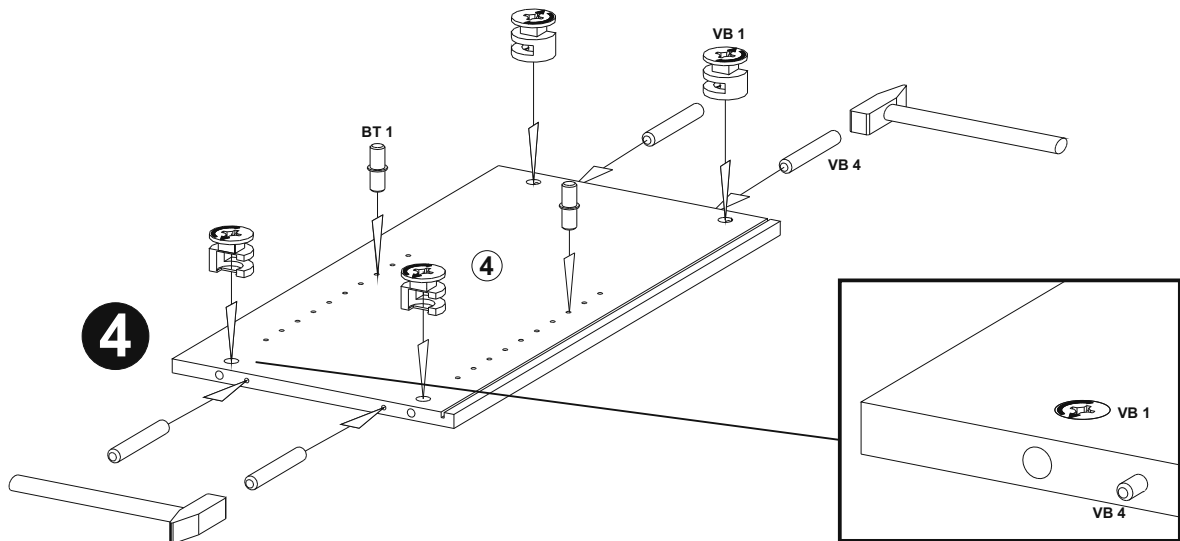
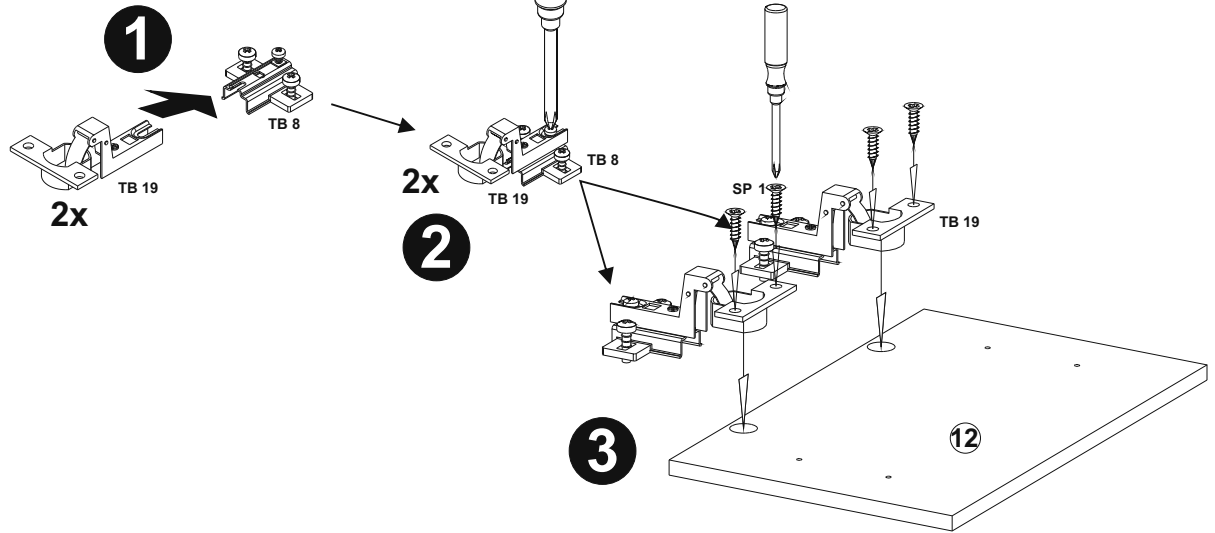
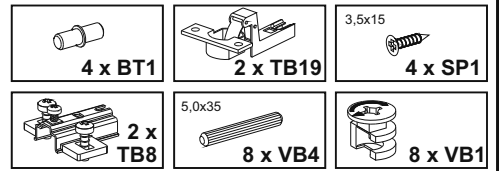
B

C

8 x BT 1



8 x VB 1

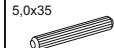

8 x VB 4



2 x SK 4



4 x SO 1

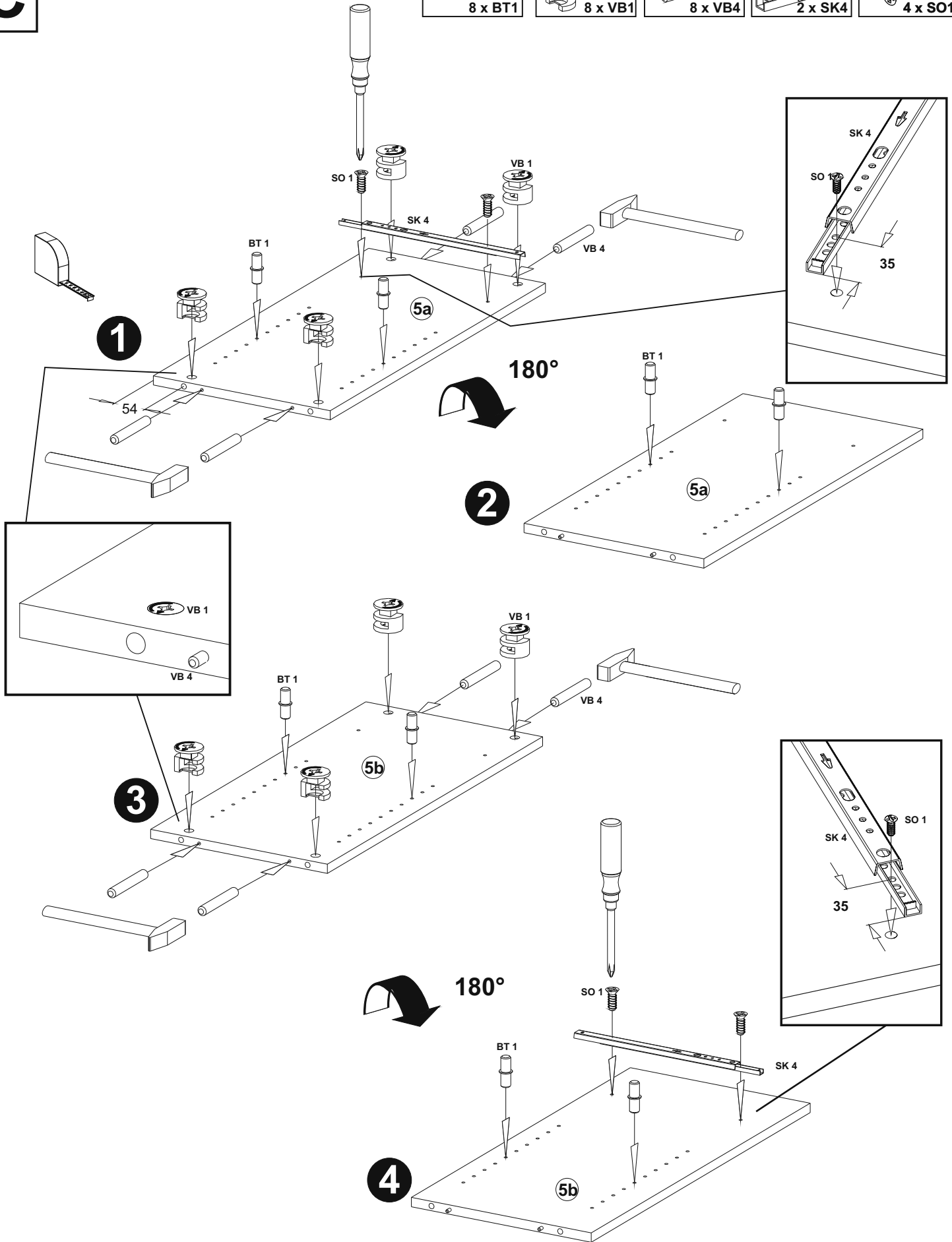

D1

A

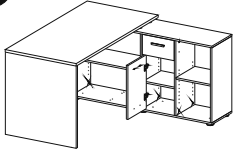

C

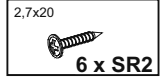
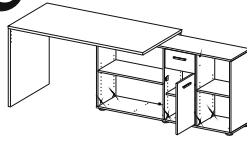

1

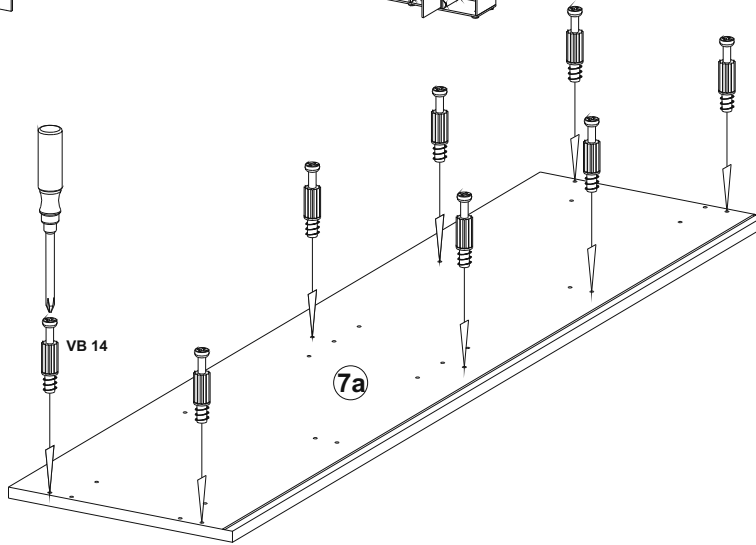

2

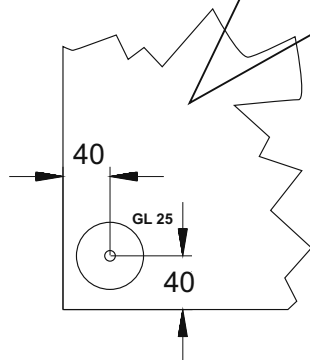
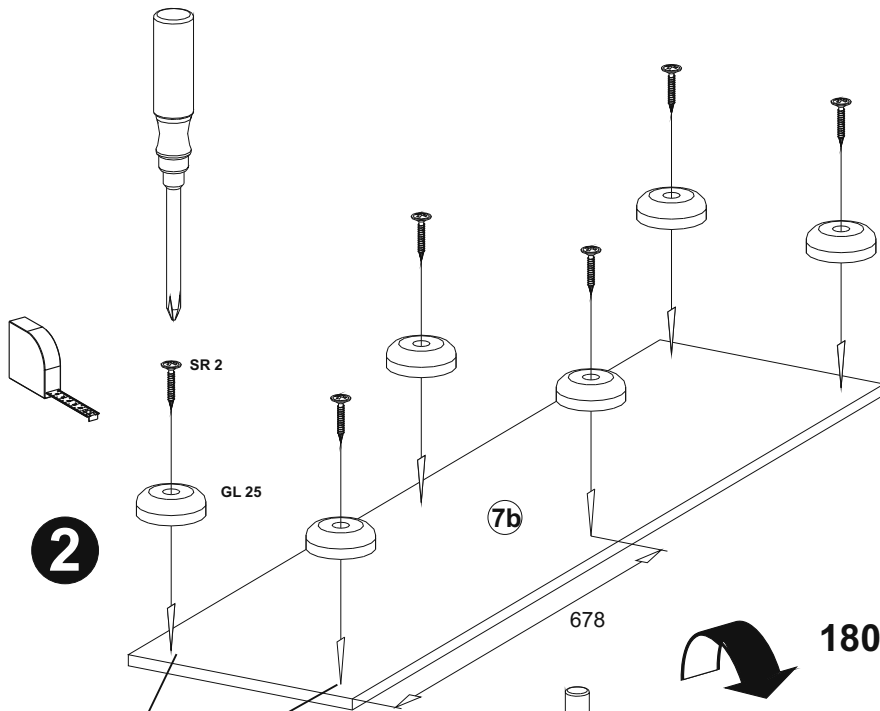

180°

3

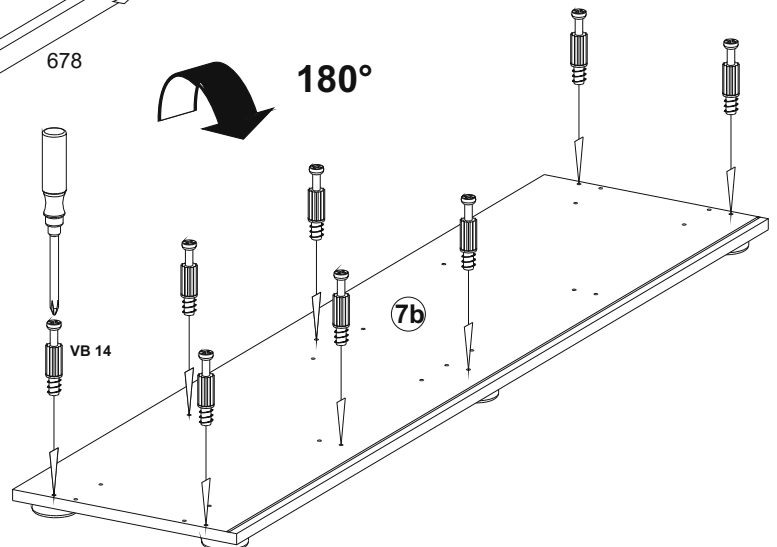

D2

B

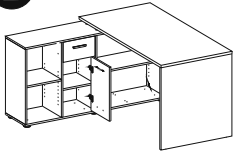

D

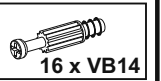
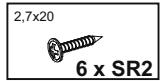
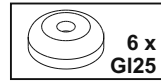
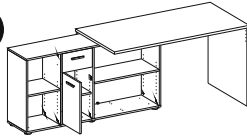

1

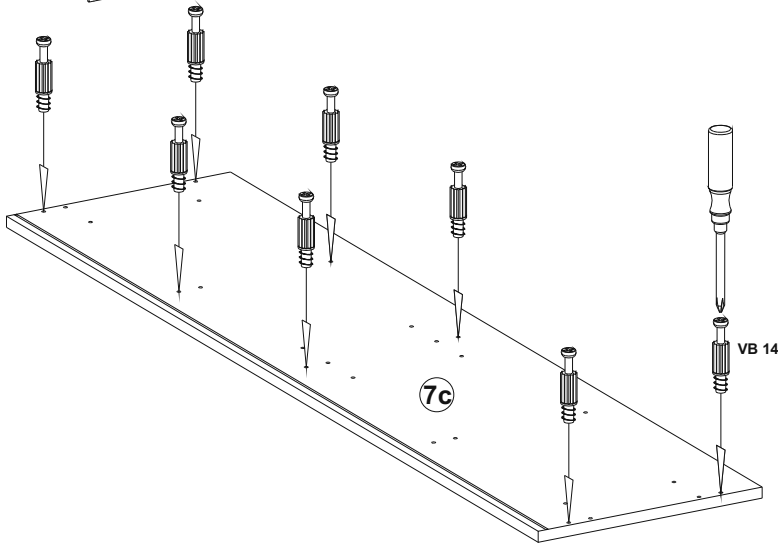

2

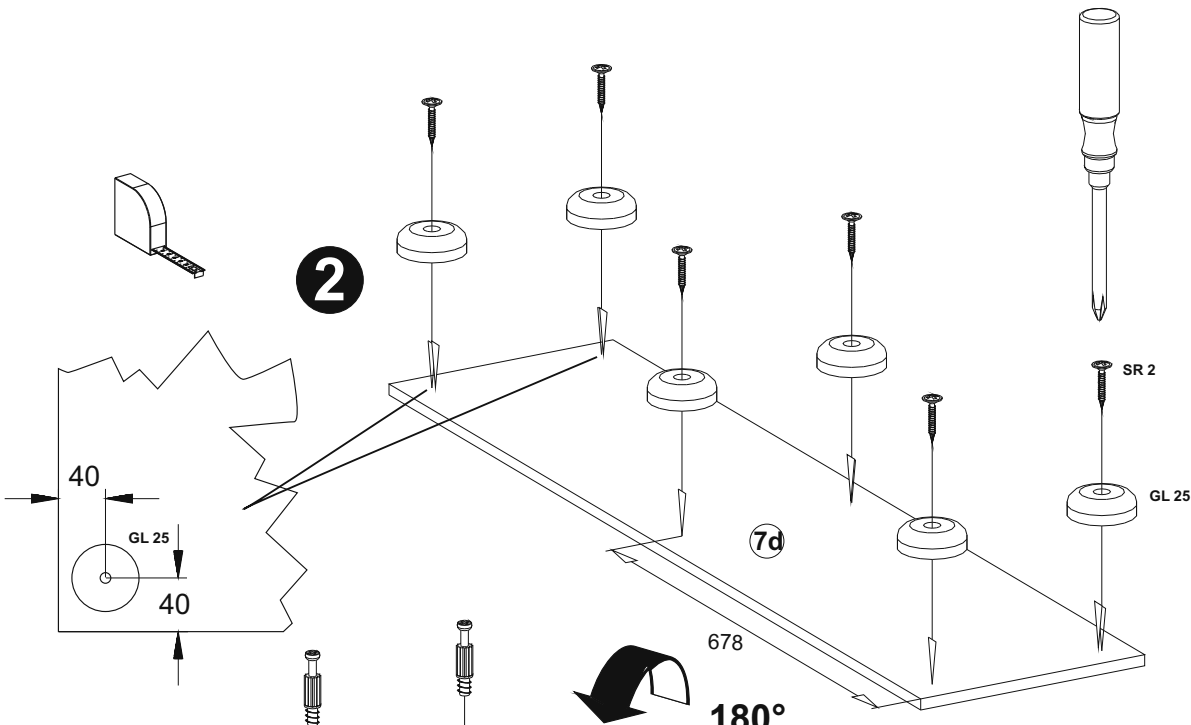

3

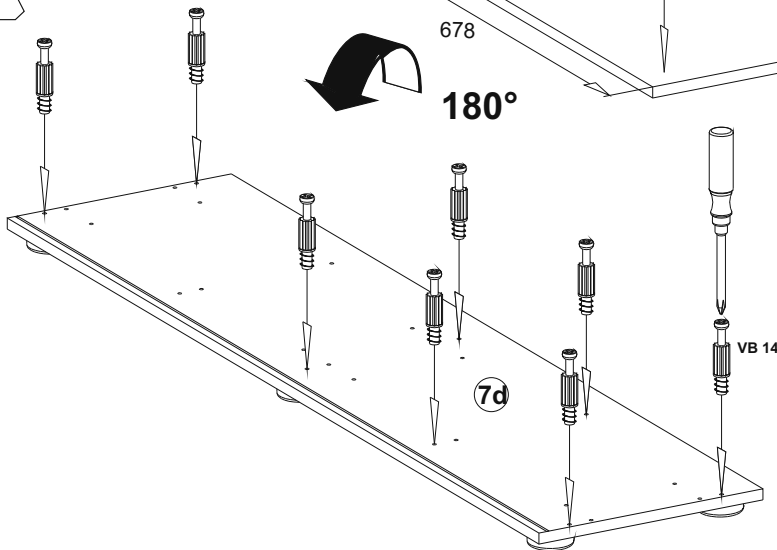

E

5,0x35

2 x VB4

2 x VB1

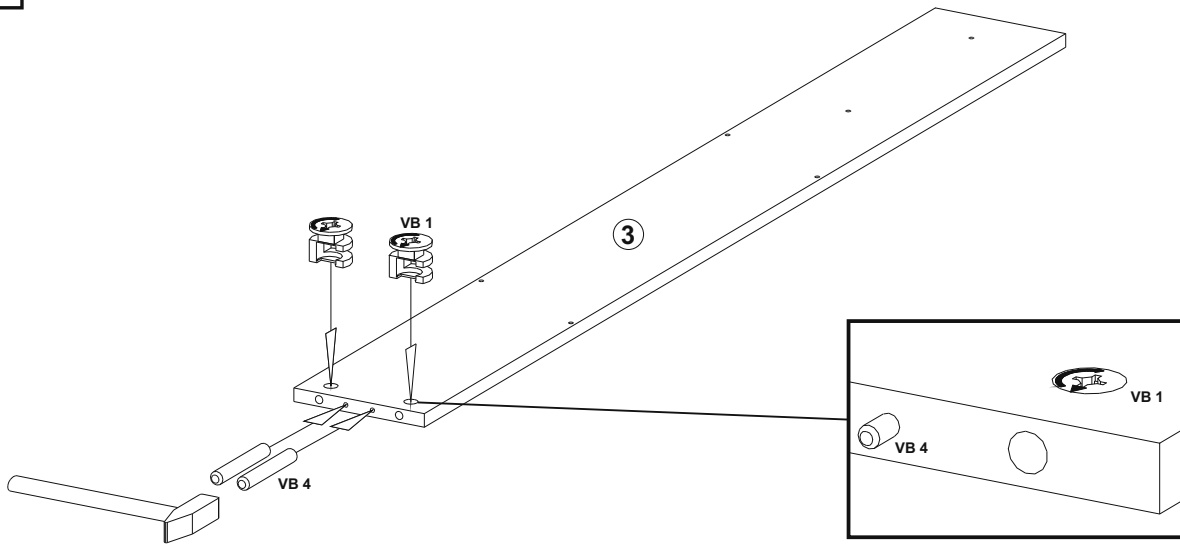

F1

A

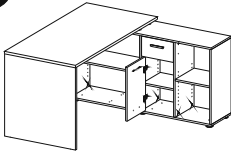

2 x VB5

3 x VB6

5 x VB14

2 x GL7

8,0x35
4 x VB18

C

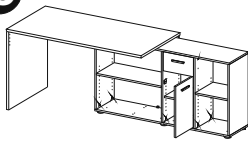

1

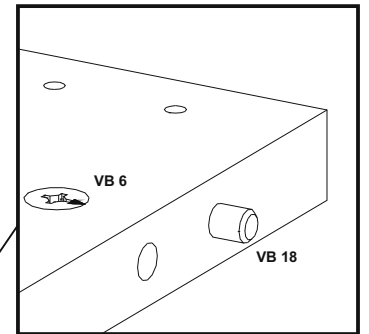
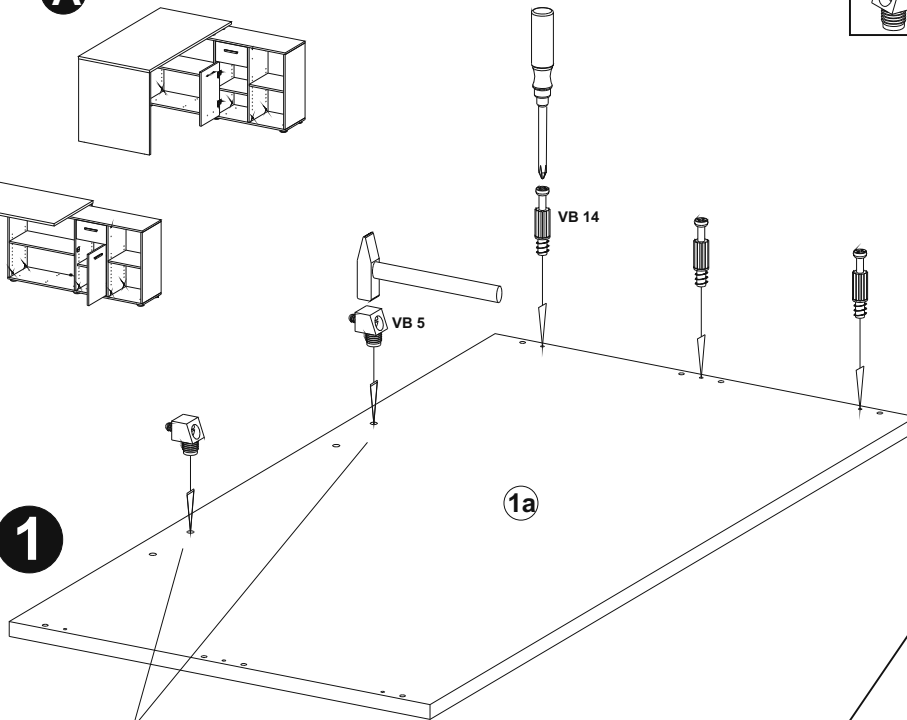

2

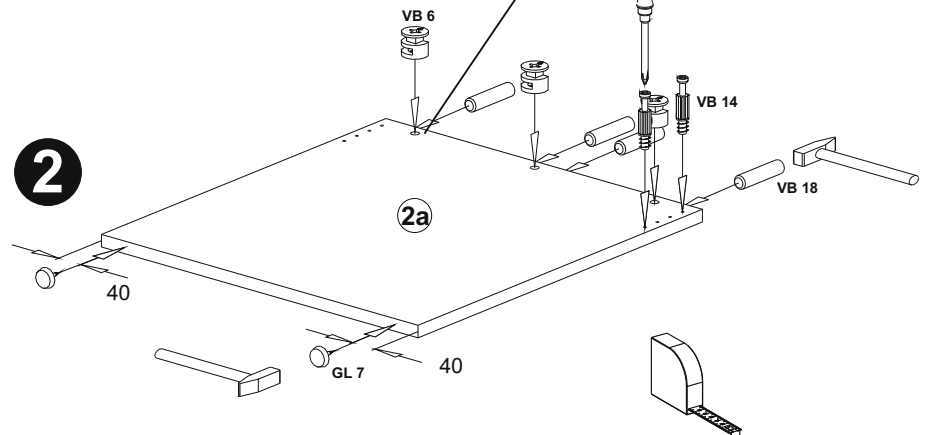
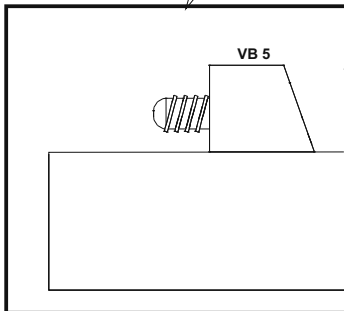

F2

B

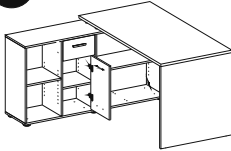

D

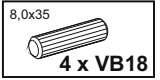
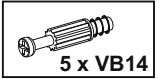
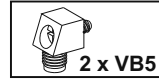
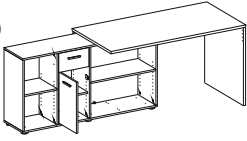

1

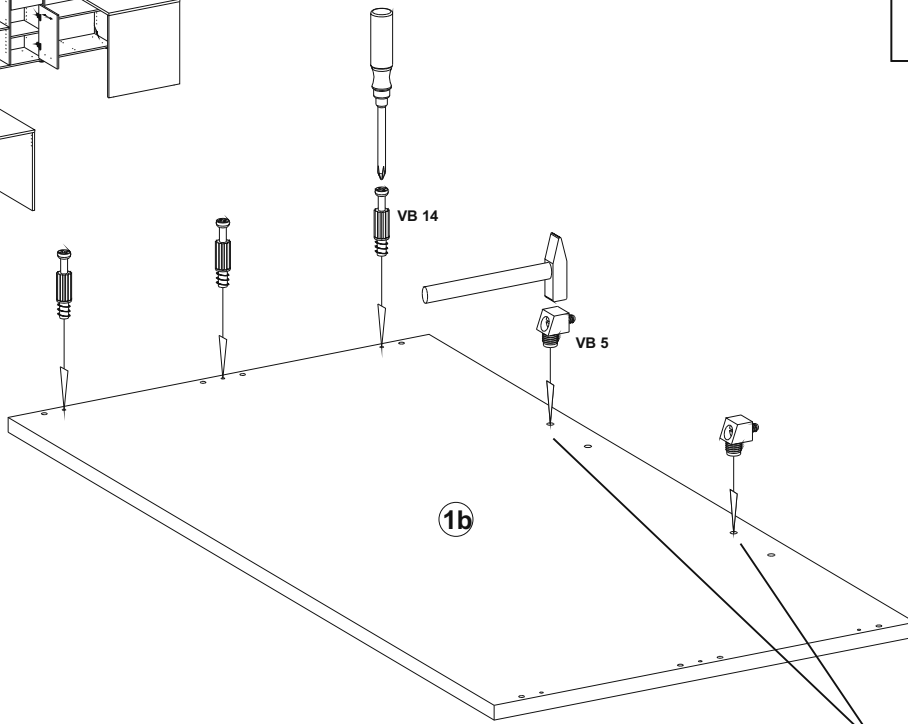

1b

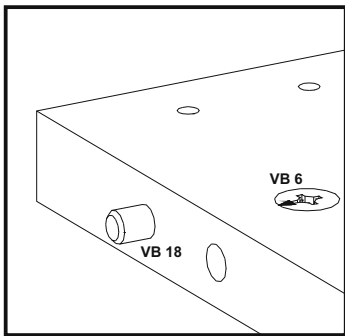

2

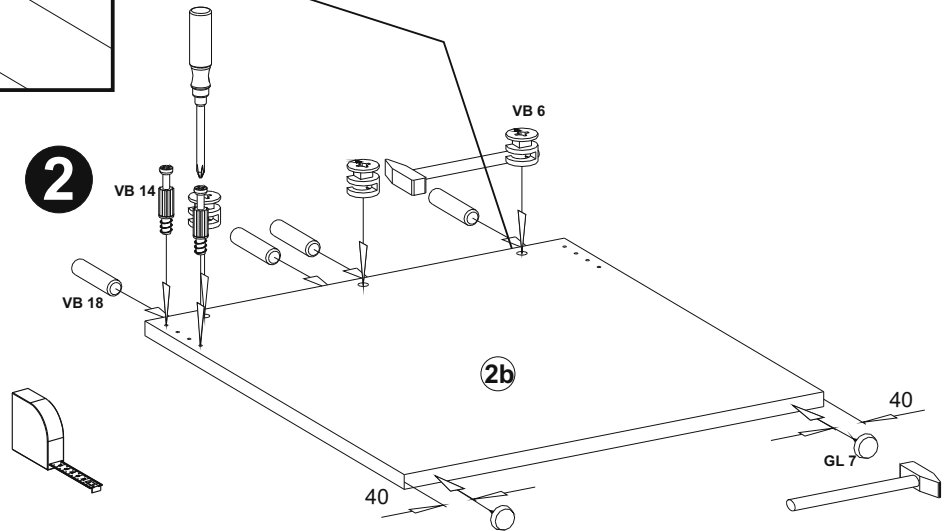

2b

G1

A

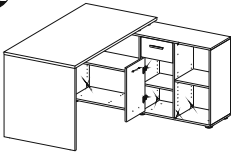

C

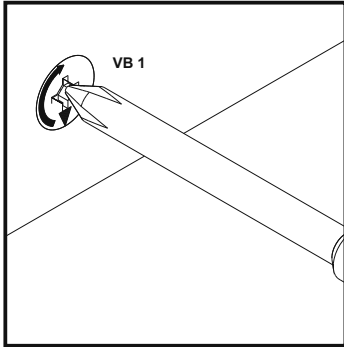
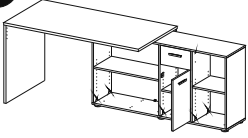

1

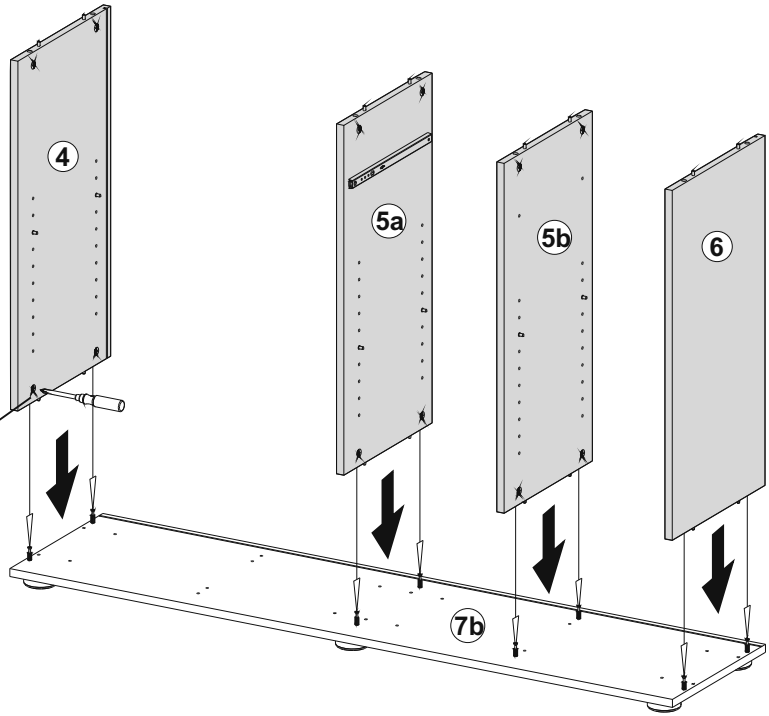

2

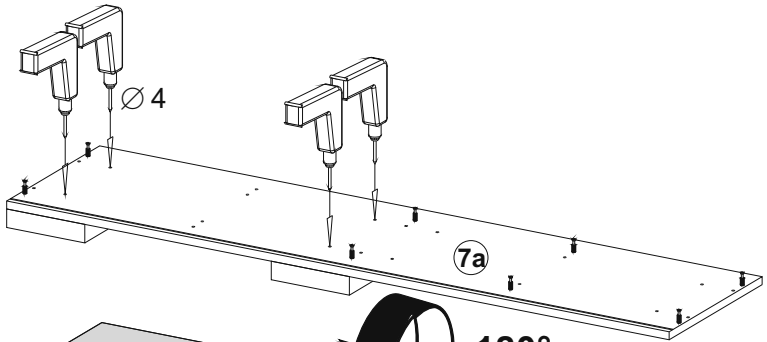

3

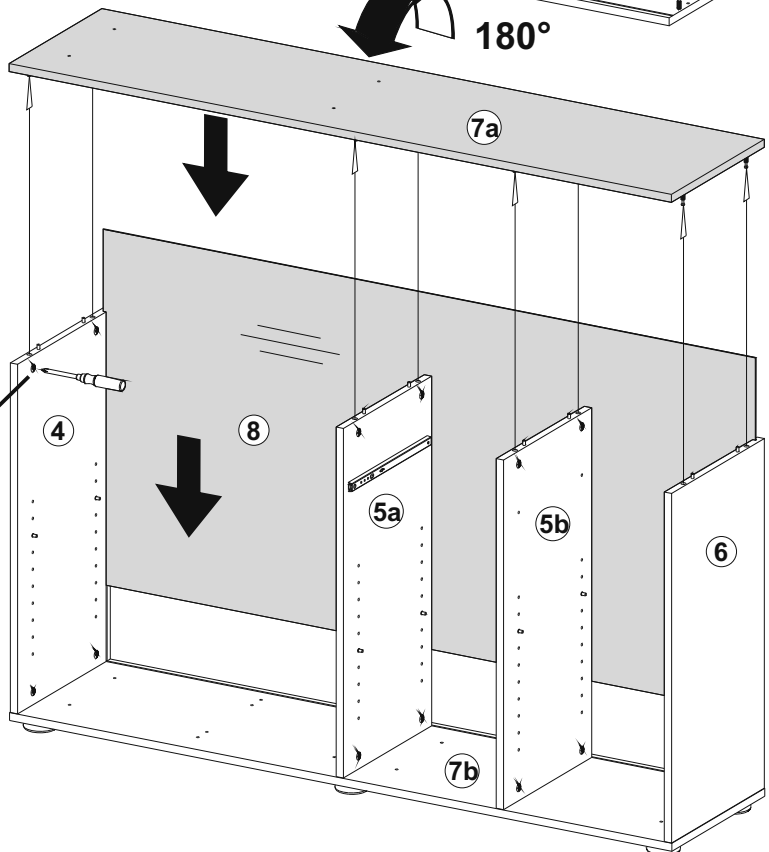
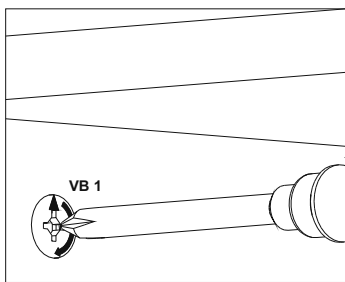

H1

A

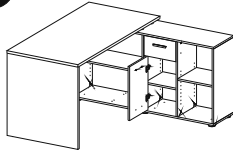

C

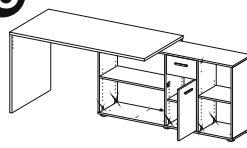

M4x8
2 x SG1

6 x
ZB 4

3,5x20
6 x SP3

4,0x45
4 x SR8

4 x
GI25

1

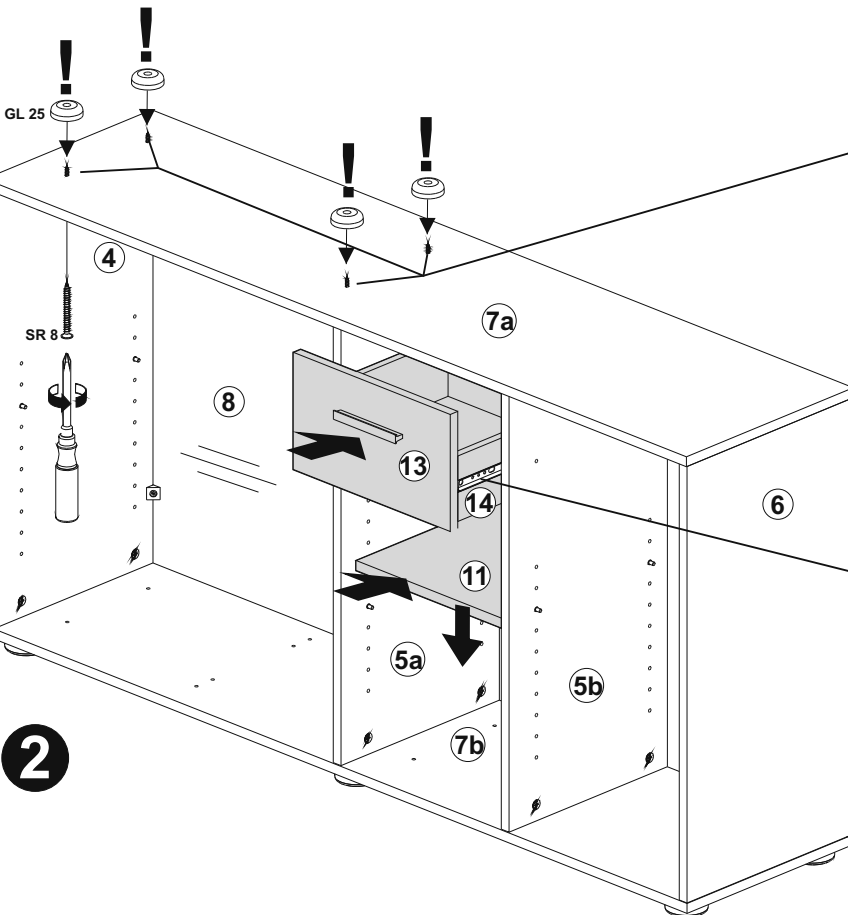
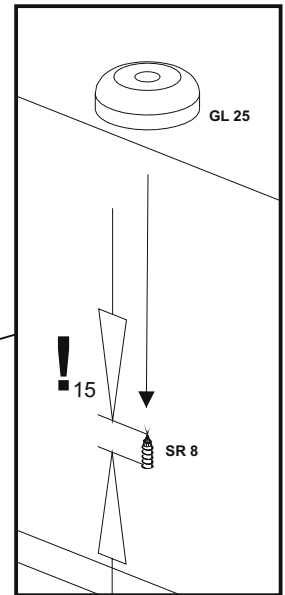
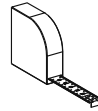
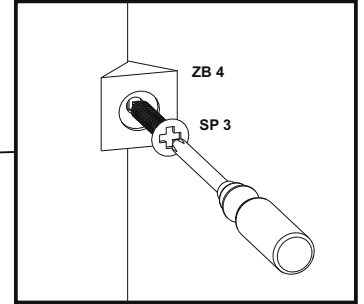
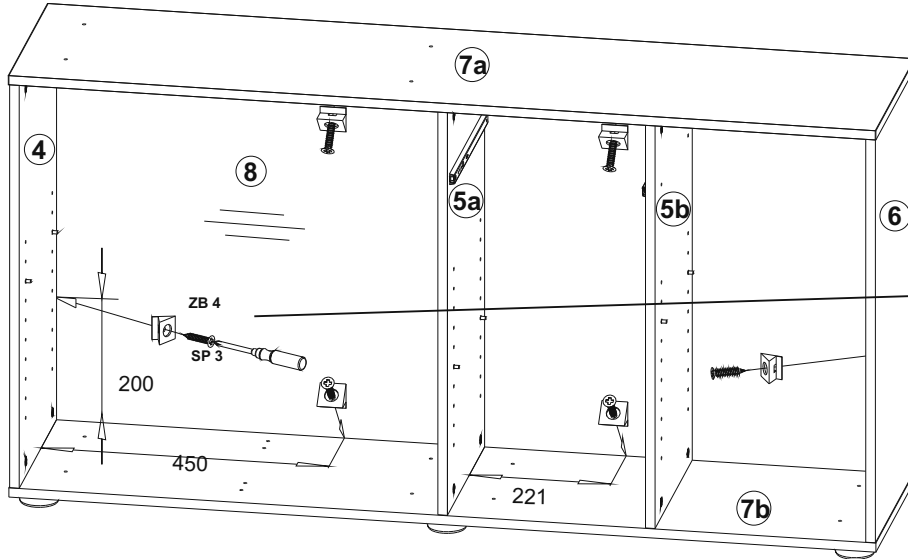

2

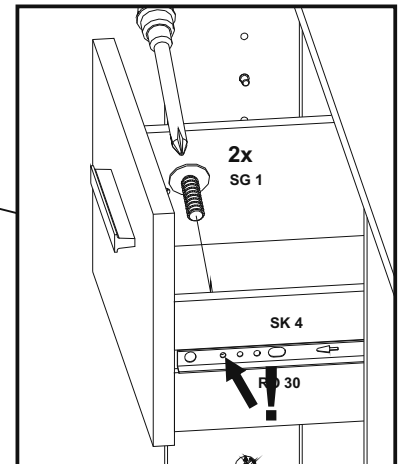

1

A

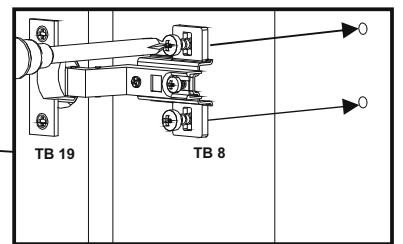
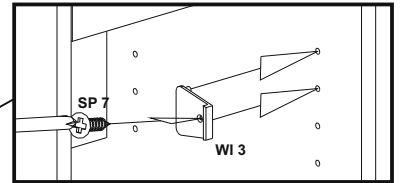
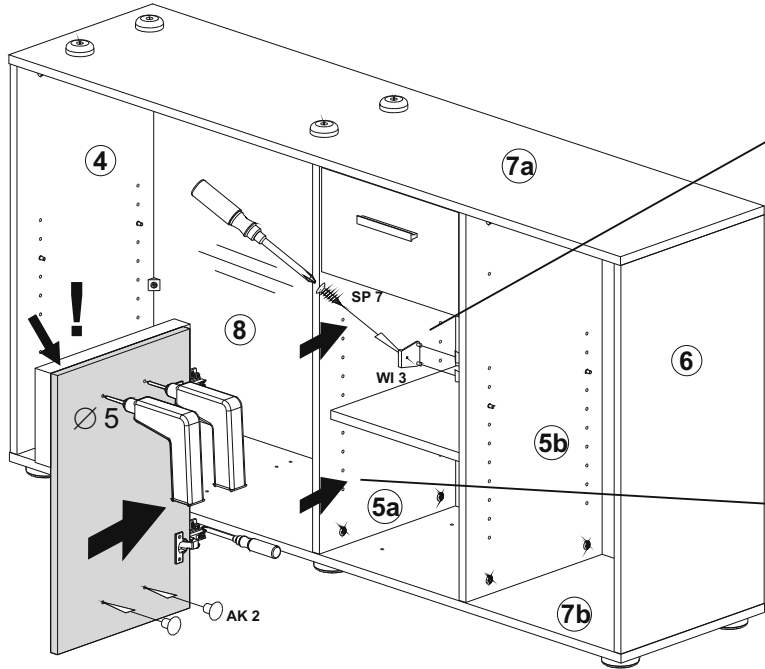
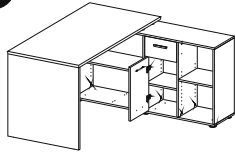
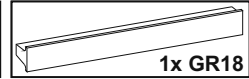
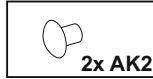
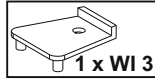

1

2

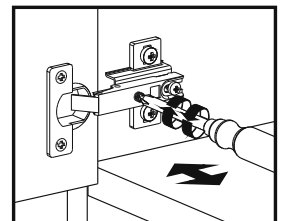
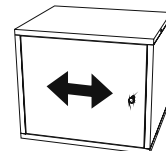
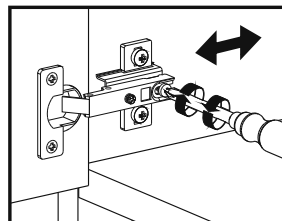
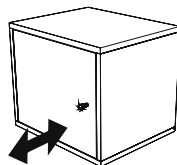
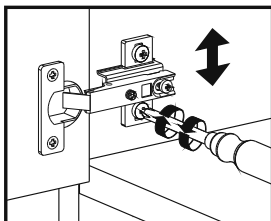
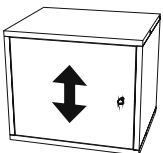
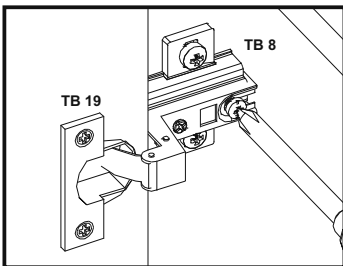
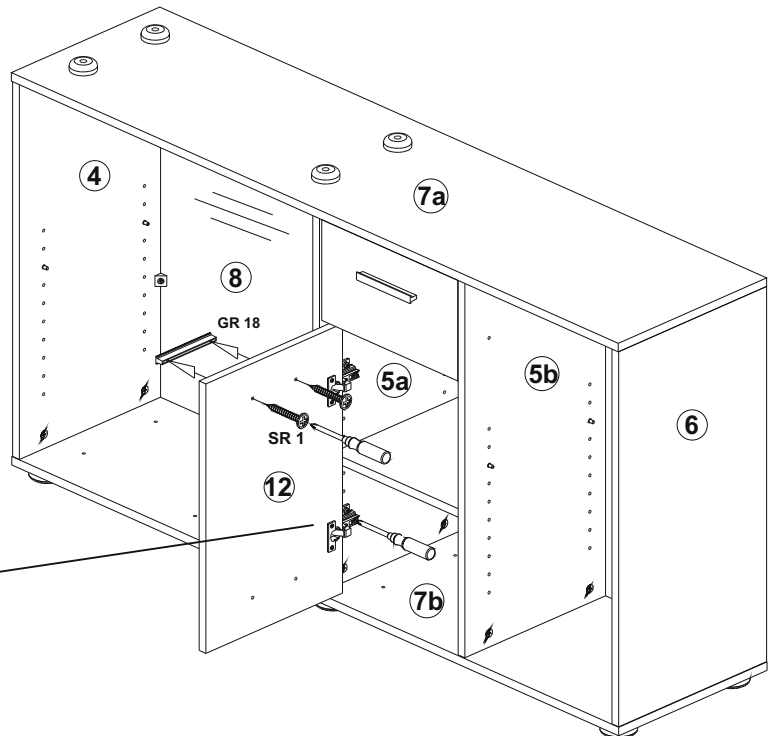

J1

A

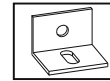
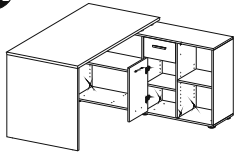

1 x
WI3

4,0x13
2 x SO14

C

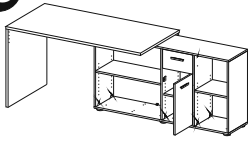

1

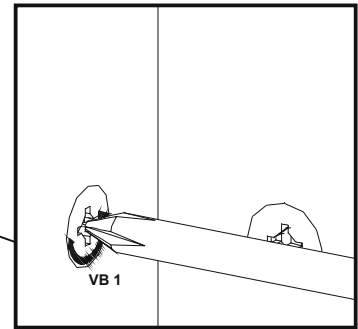
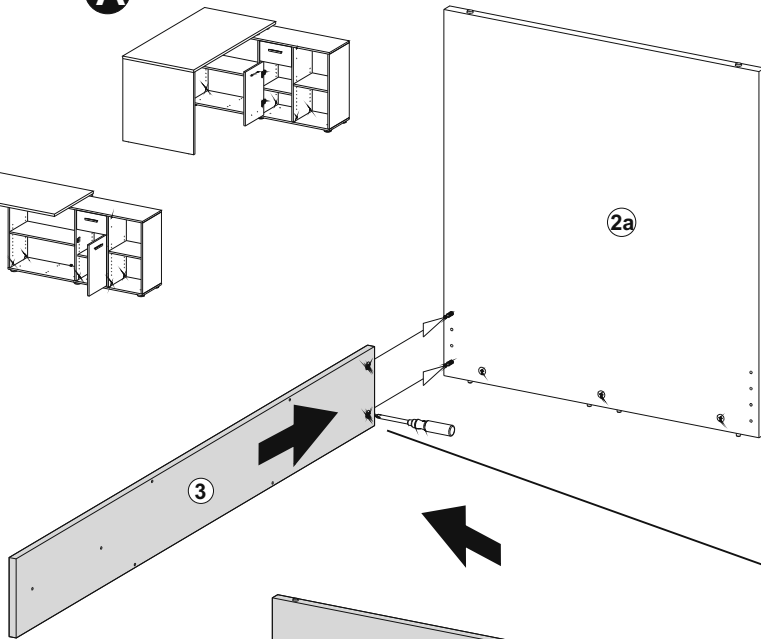

2

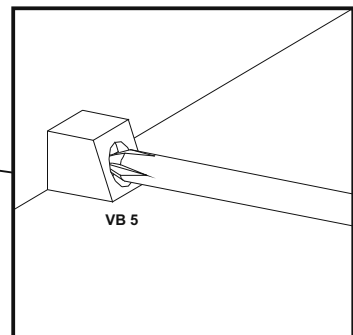
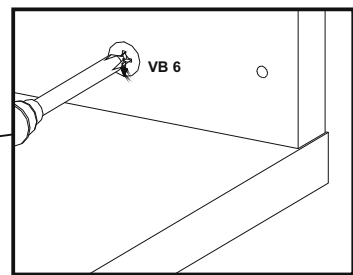
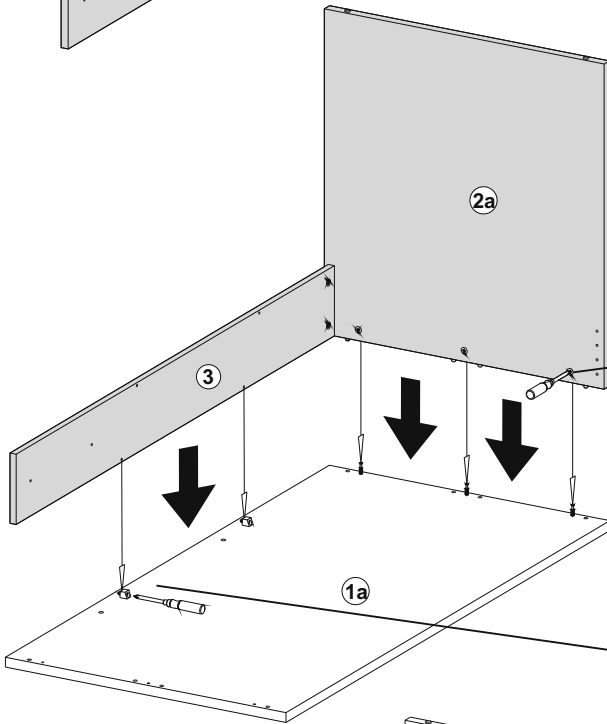

3

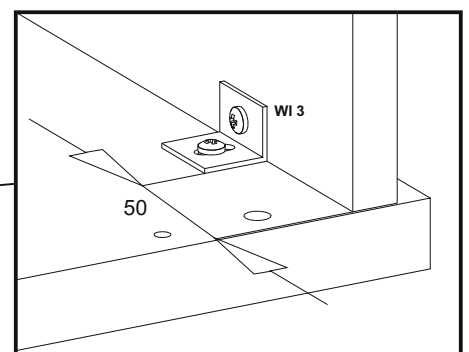
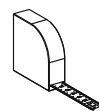
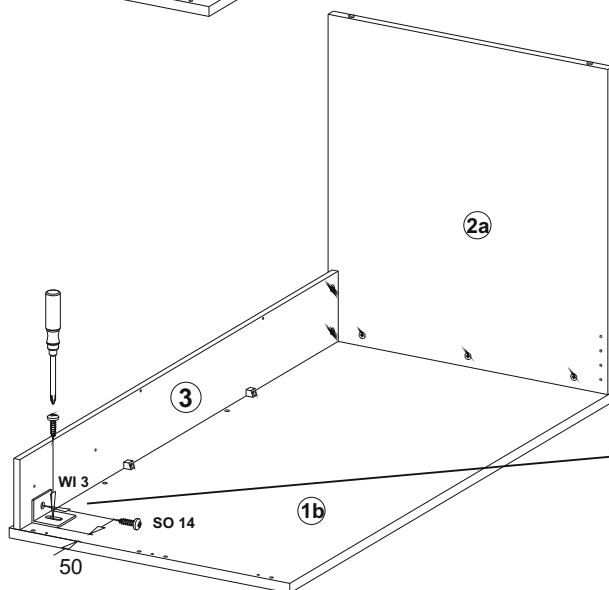

K1

A

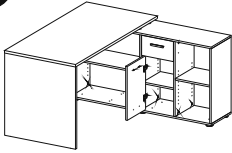

3,5x22
2 x SP10

4x25
2 x SP11

AK1
4 x AK1

1

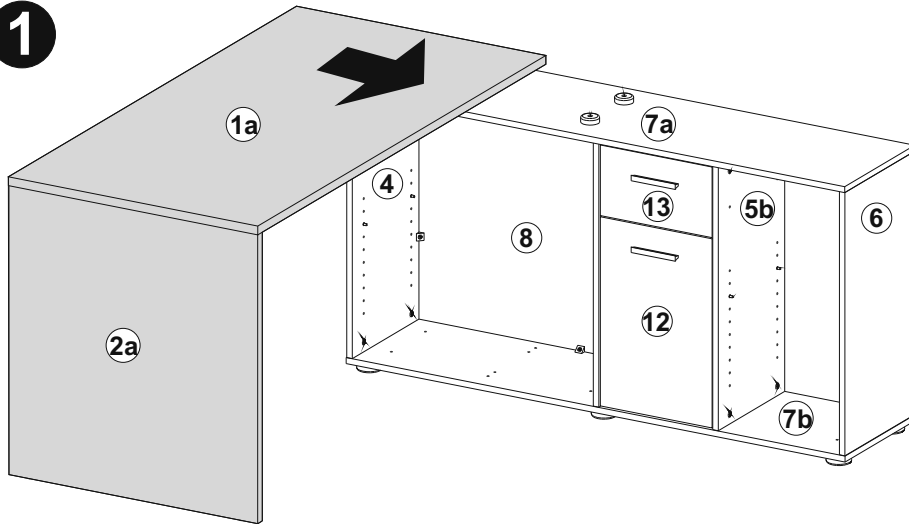

2

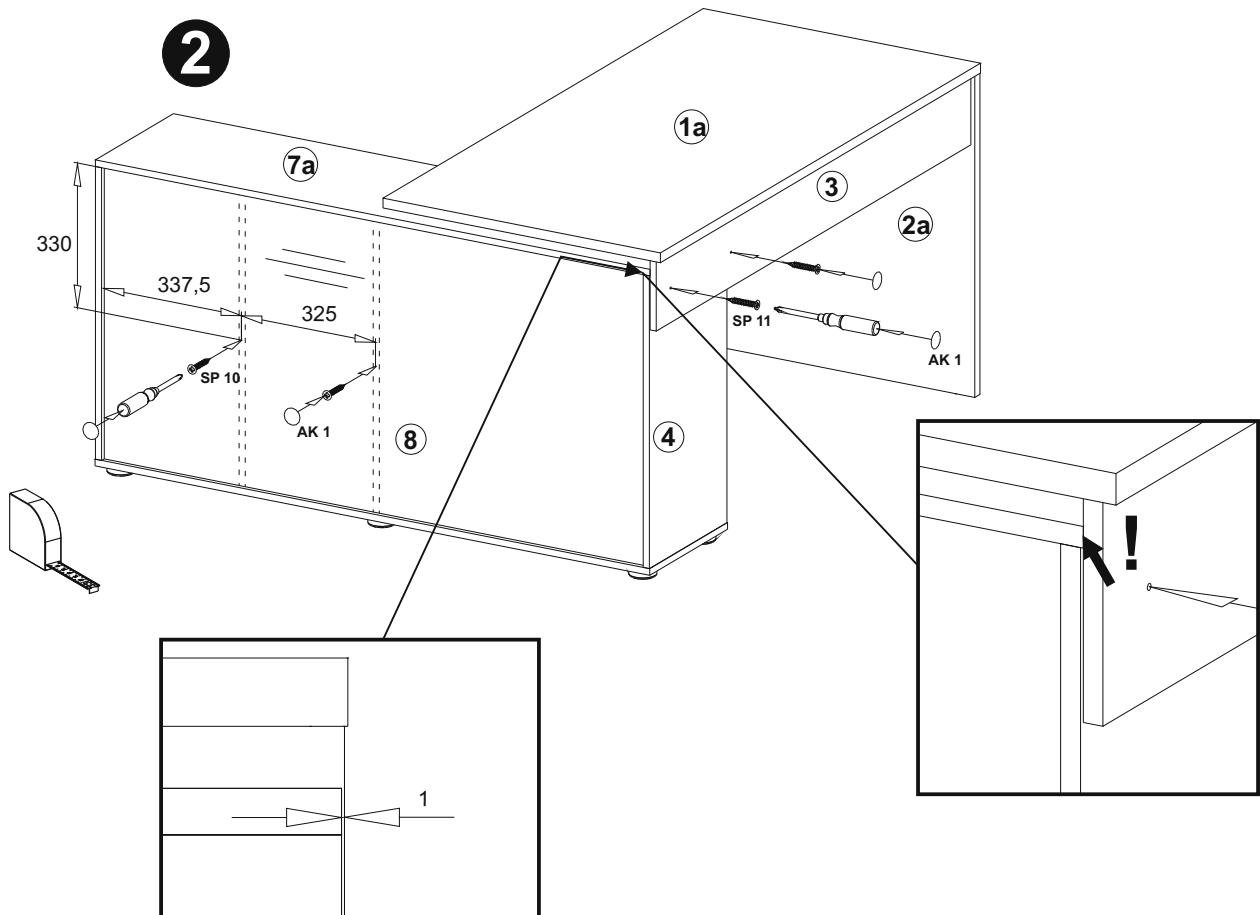

L1

A

12x AK2

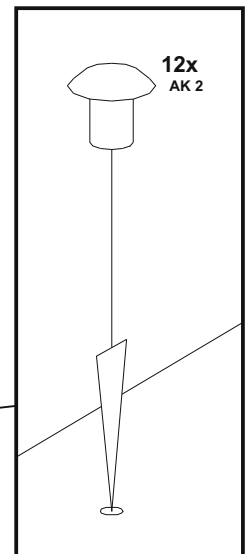
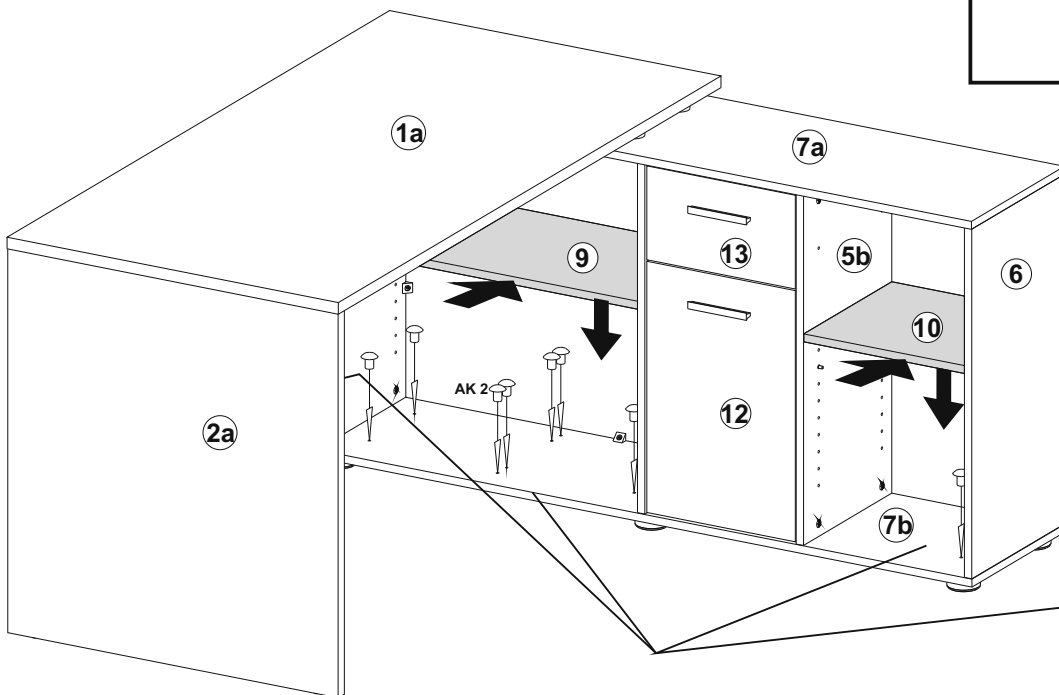
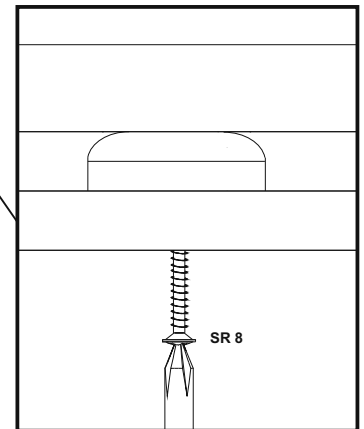
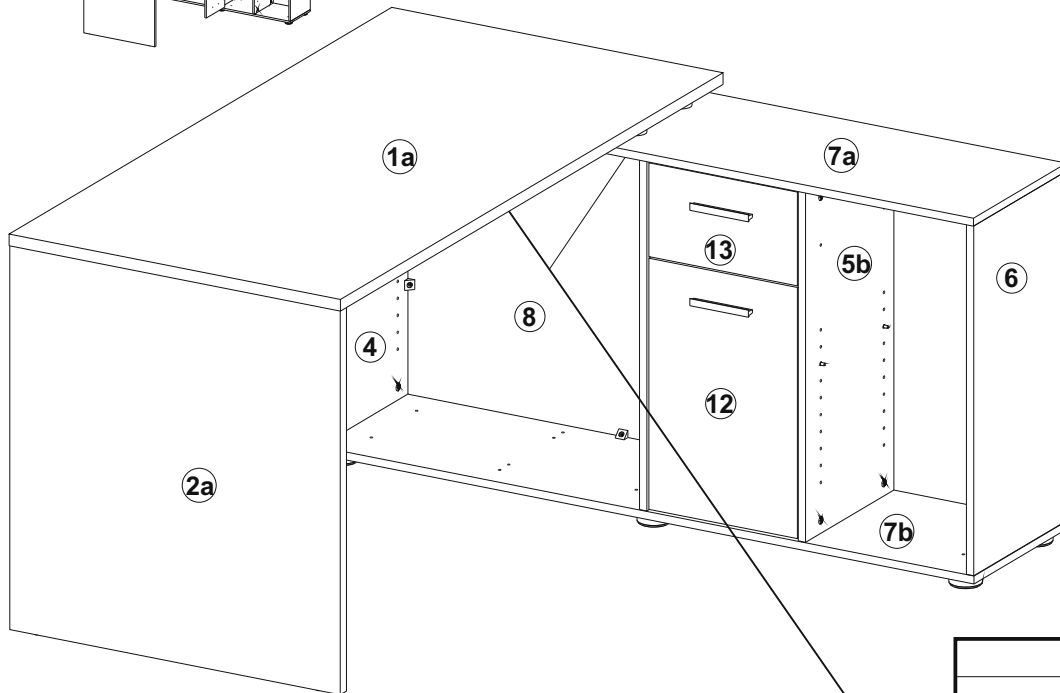
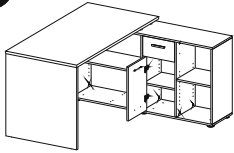

G2

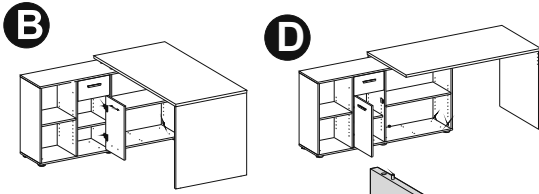

1

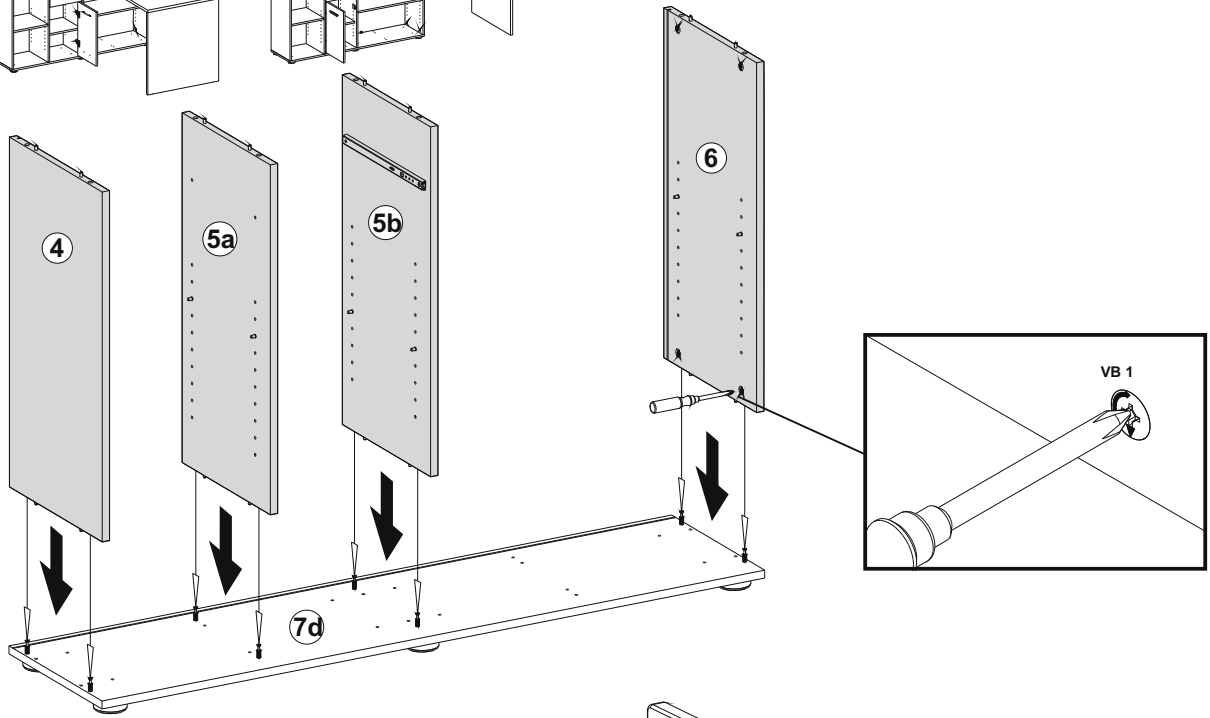

2

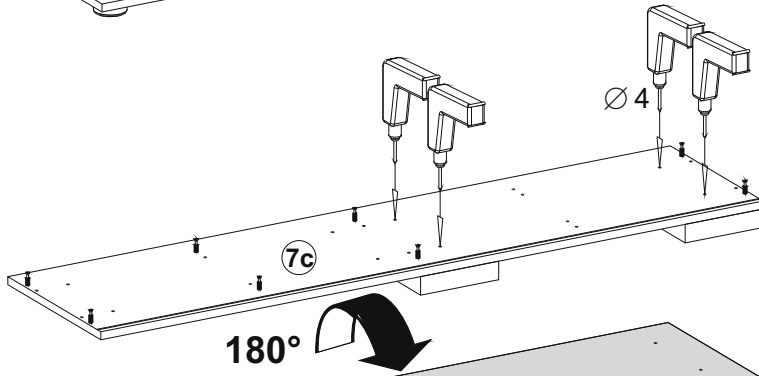

3

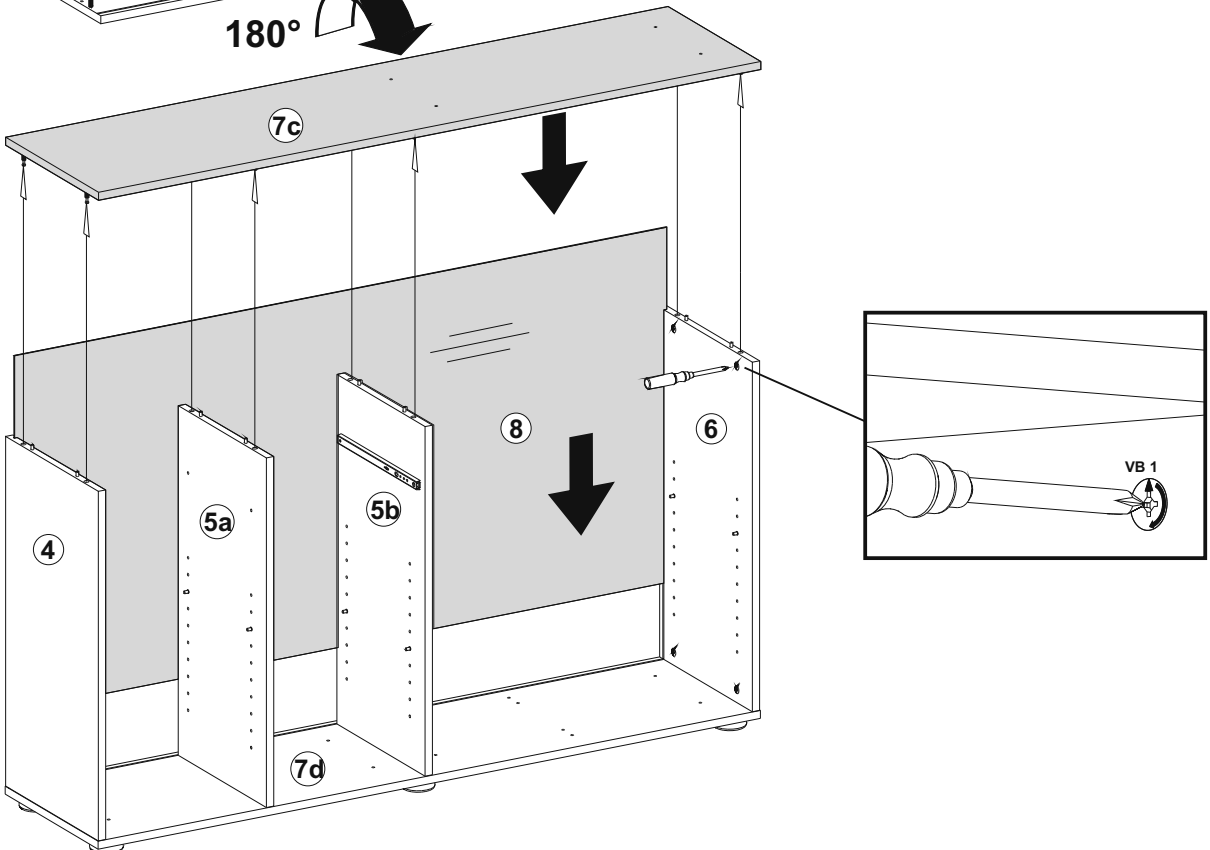

H2

B

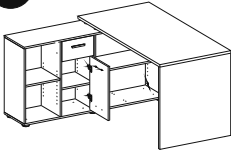

D

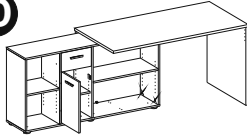

M4x8
2 x SG1

6 x
ZB 4

3,5x20
6 x SP3

4,0x45
4 x SR8

4 x
GI25

1

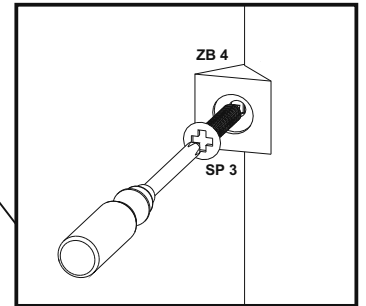
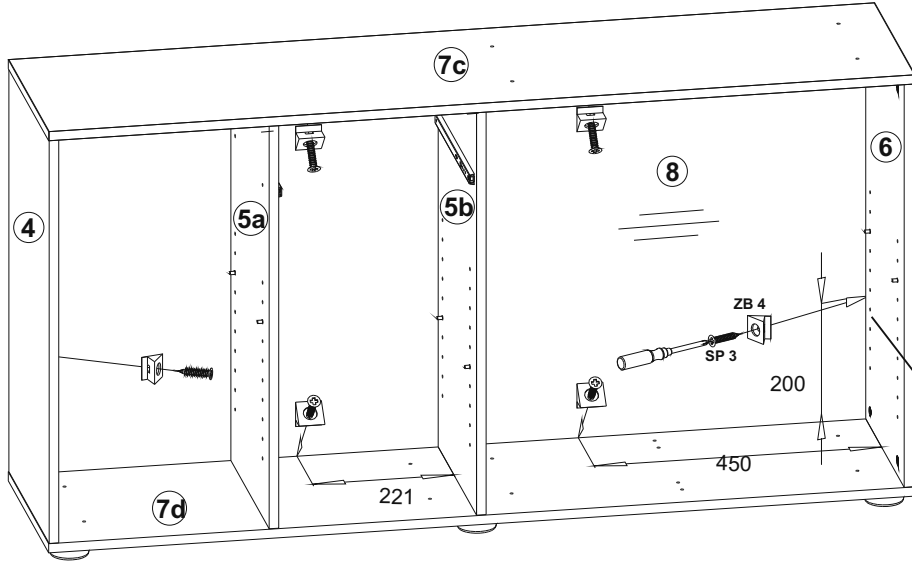

2

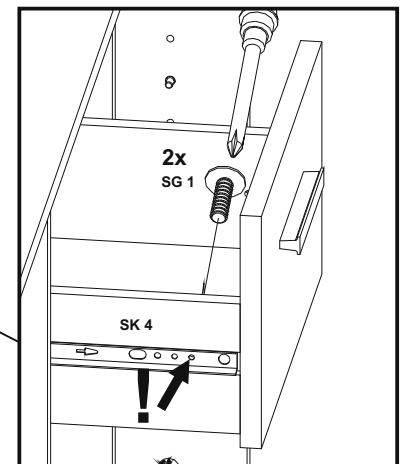
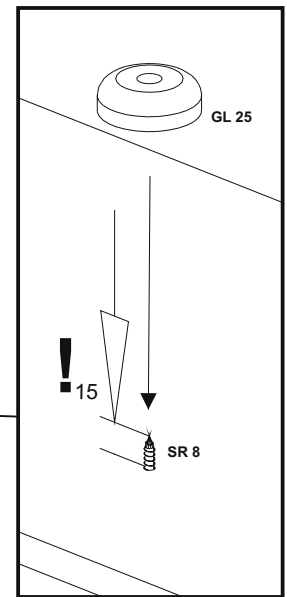
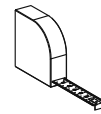
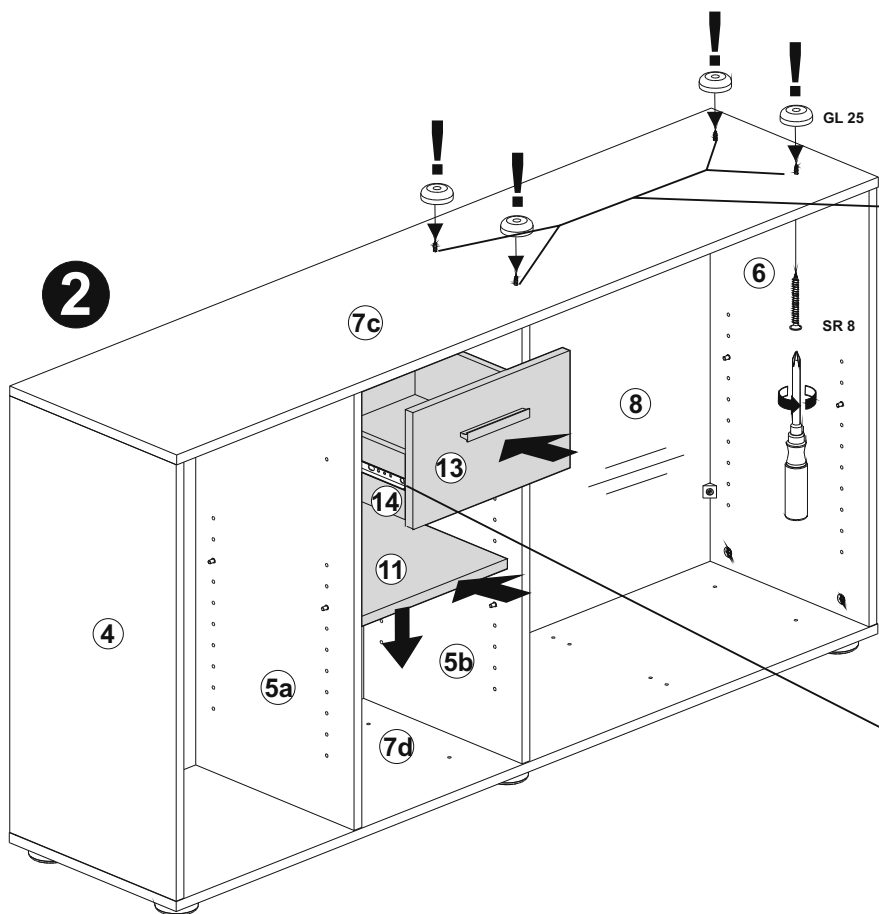

12

B

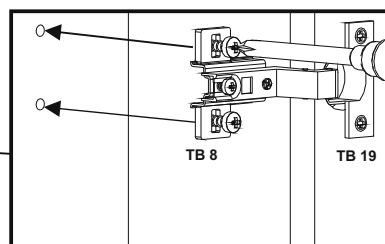
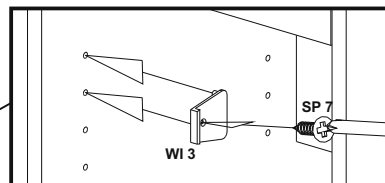
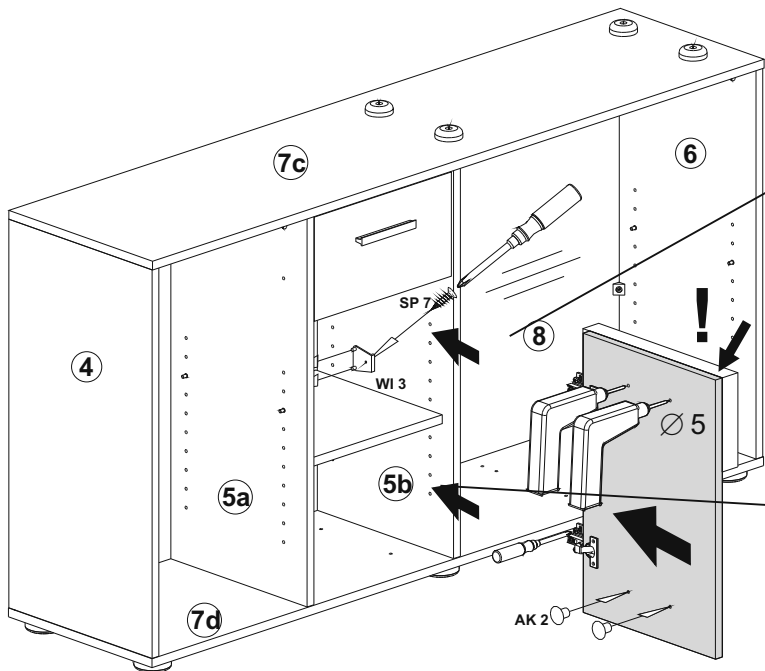
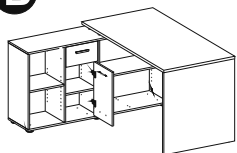
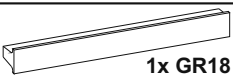
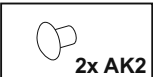
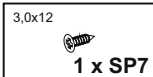
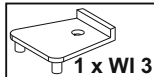

1

2

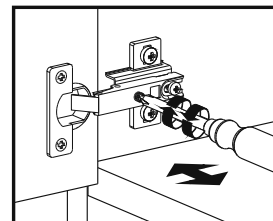
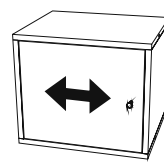
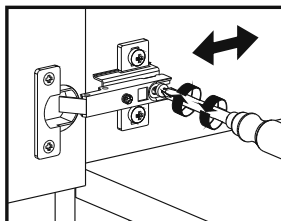
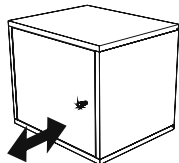
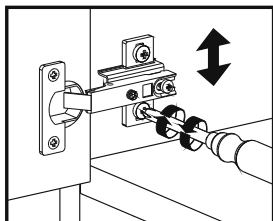
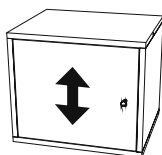
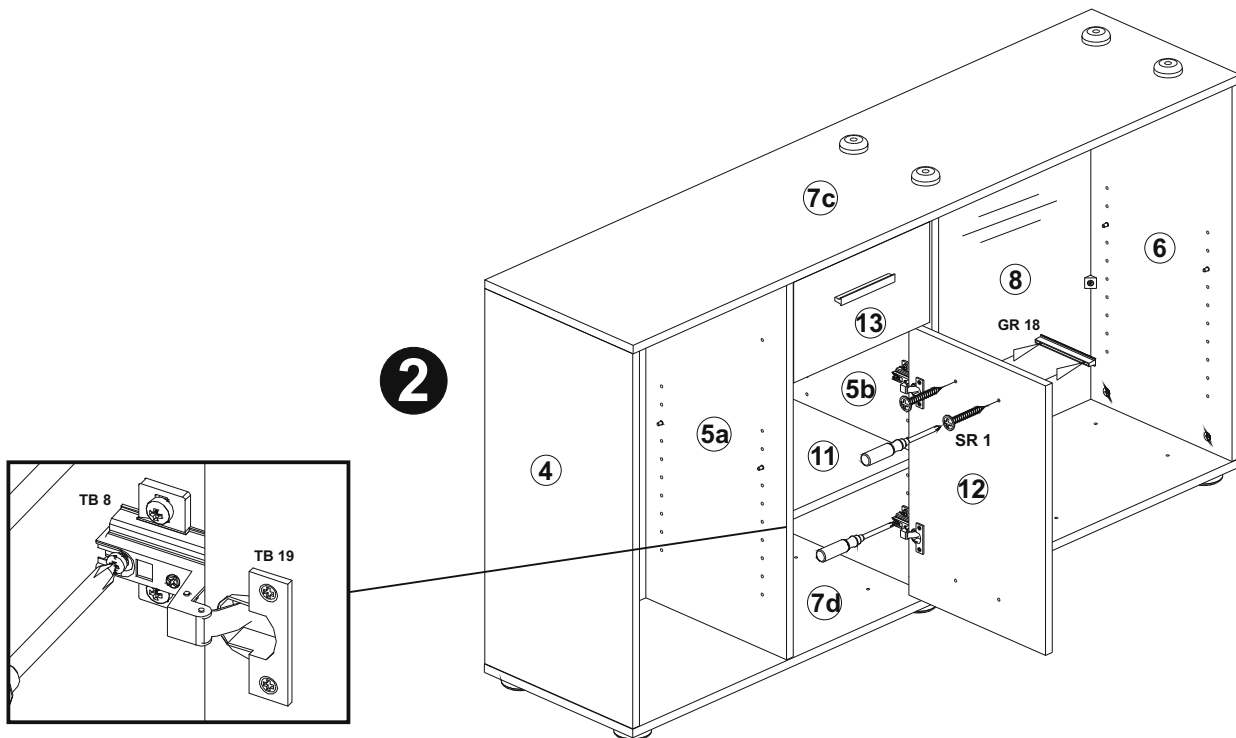

J2

B

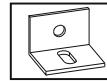
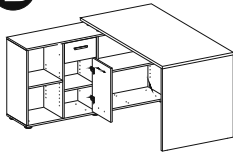

1 x
WI3

4,0x13
2 x SO14

D

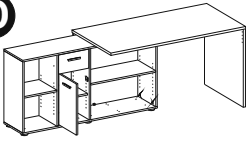

1

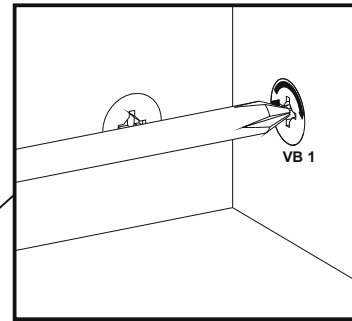
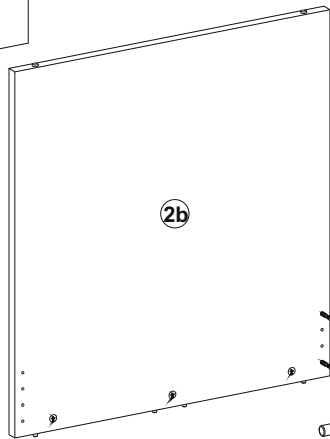

2

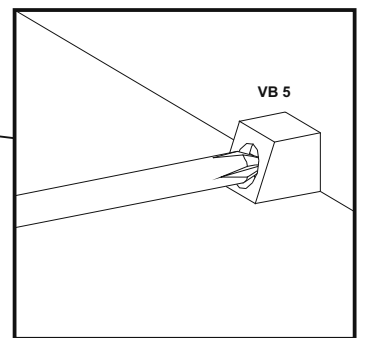
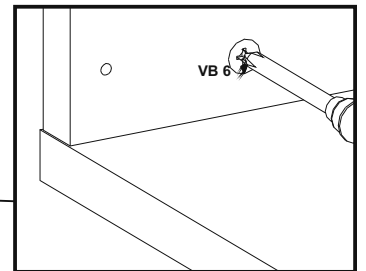
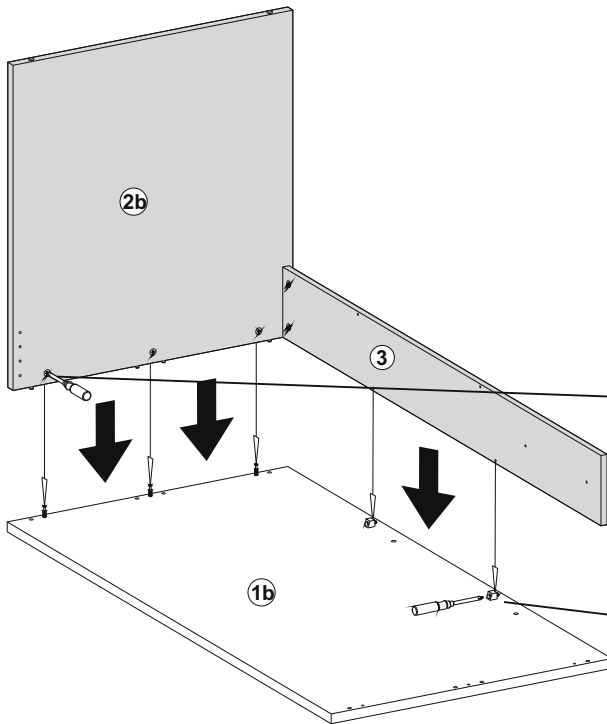

3

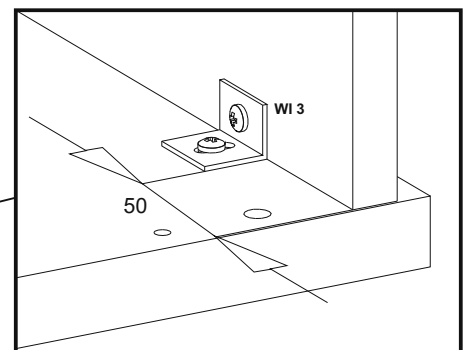
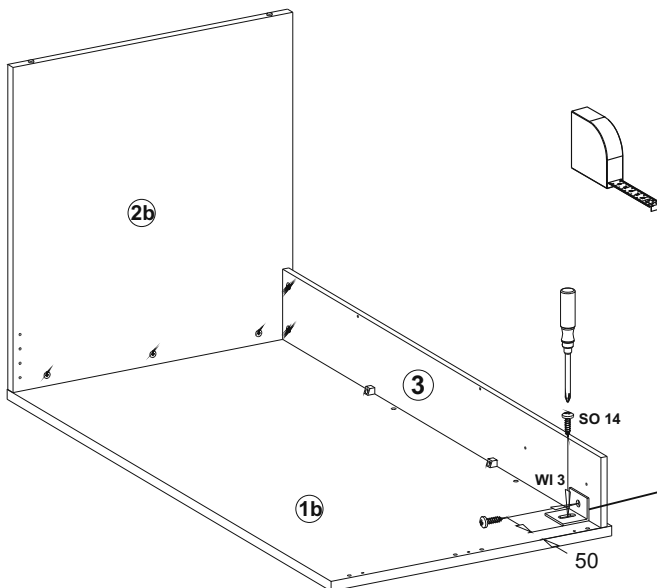

K2

B

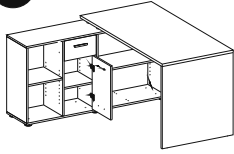

3.5x22
2 x SP10

4x25
2 x SP11

AK1
4 x AK1

1

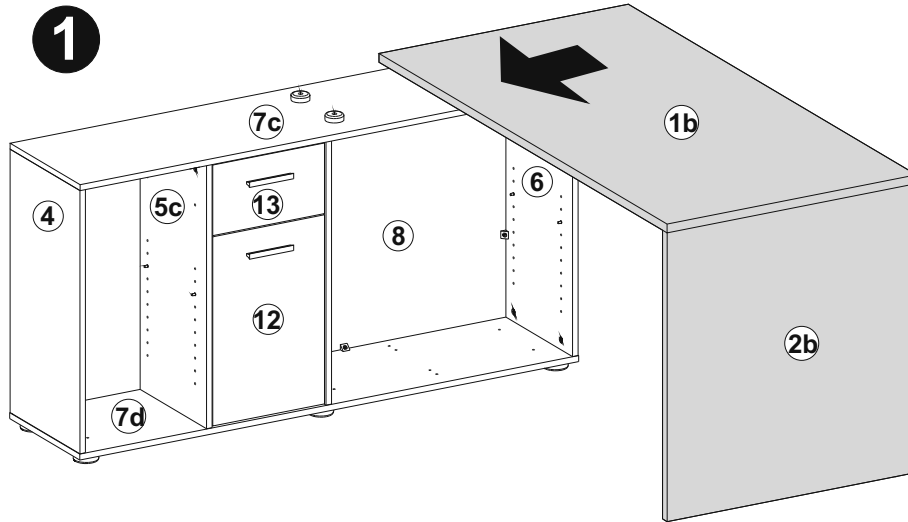

2

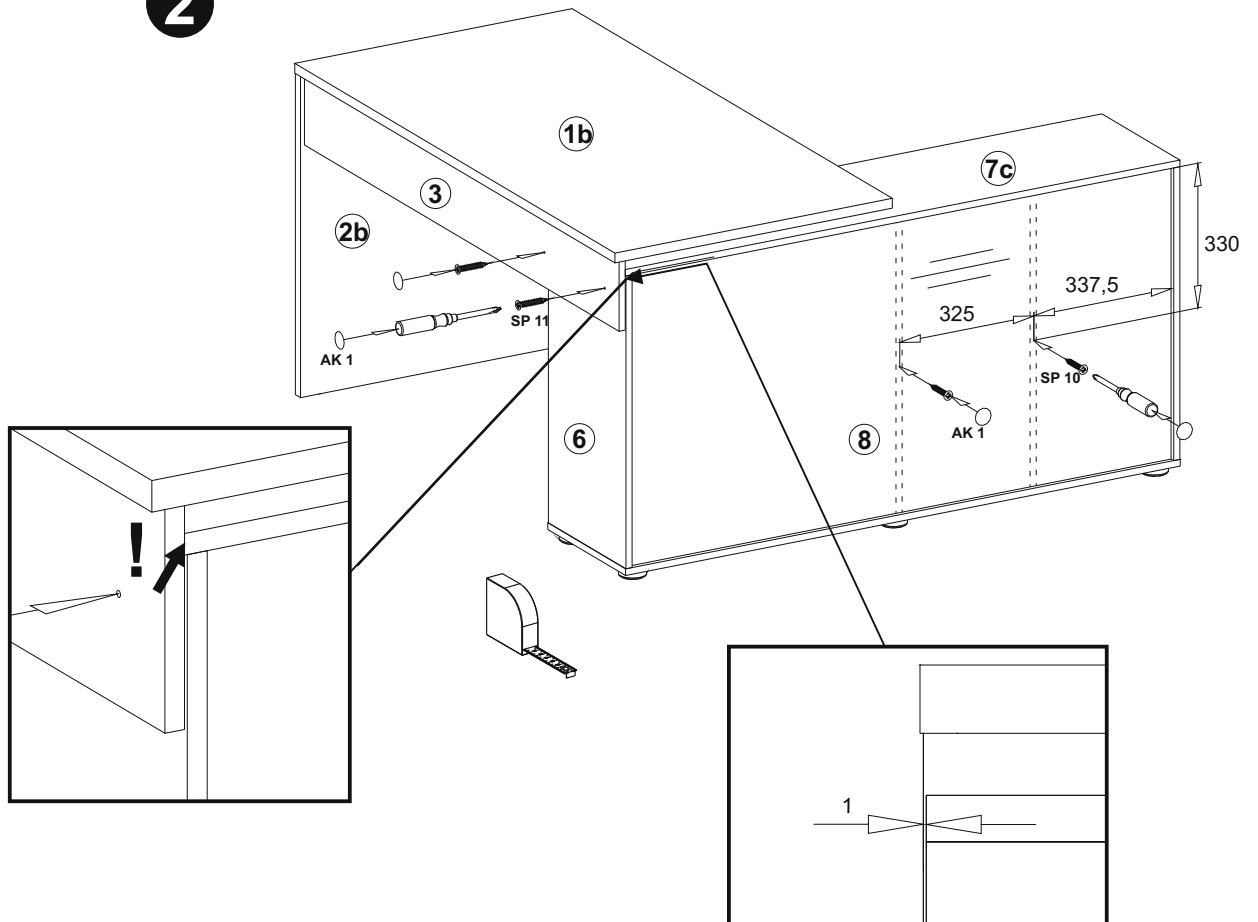

L2

B

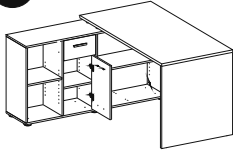

12x AK2

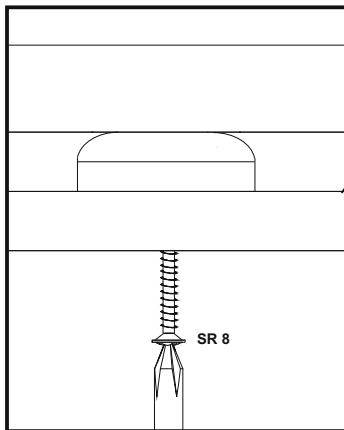
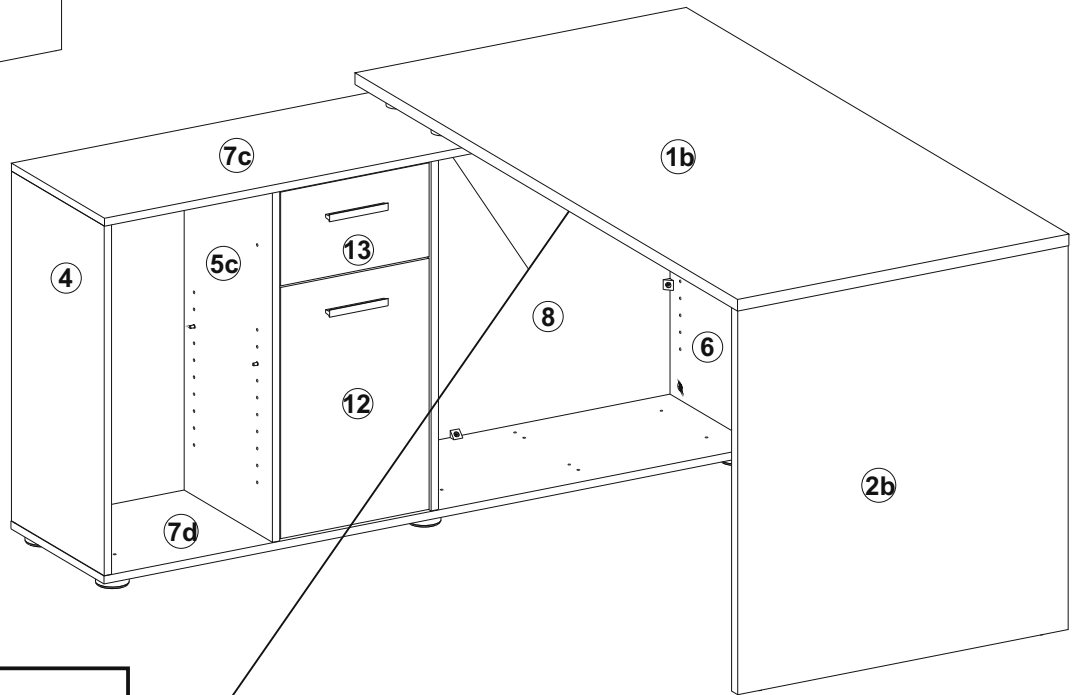

4x

SR 8

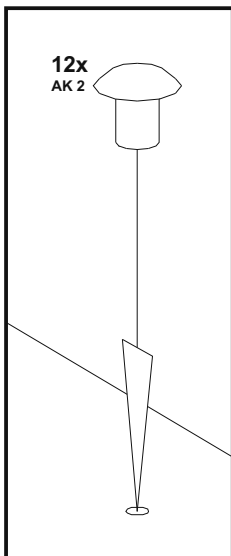

12x
AK 2

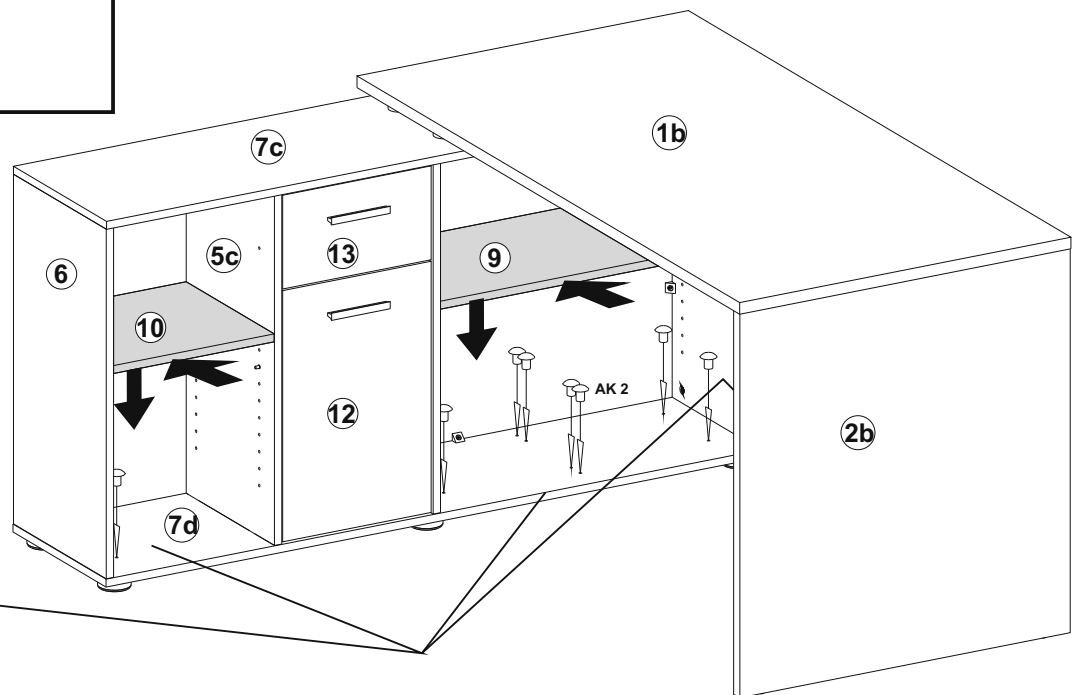

13

C

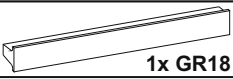
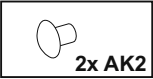
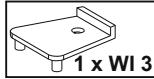

1

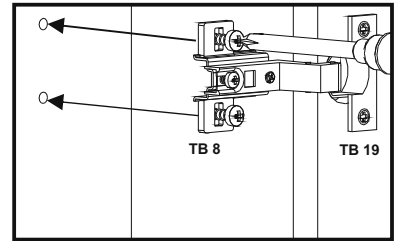
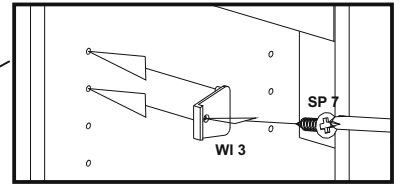
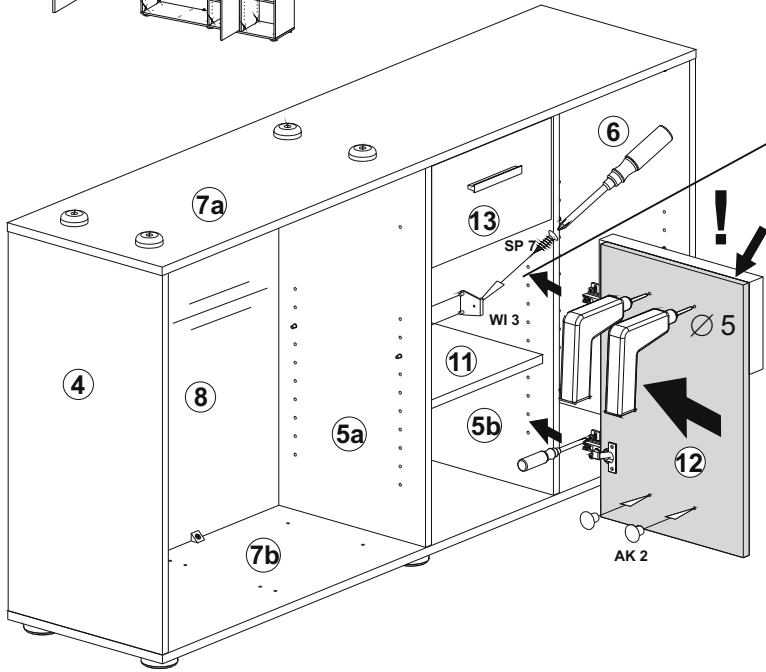

2

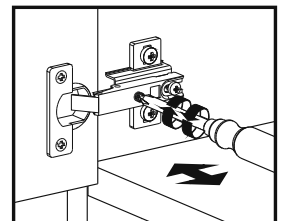
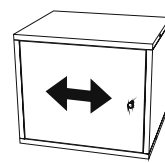
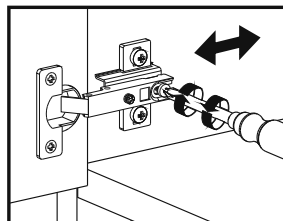
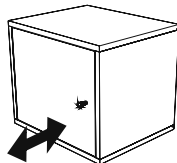
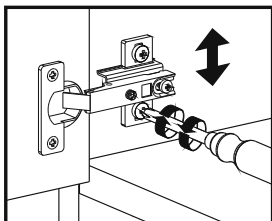
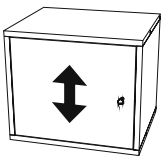
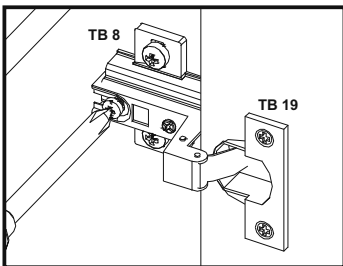
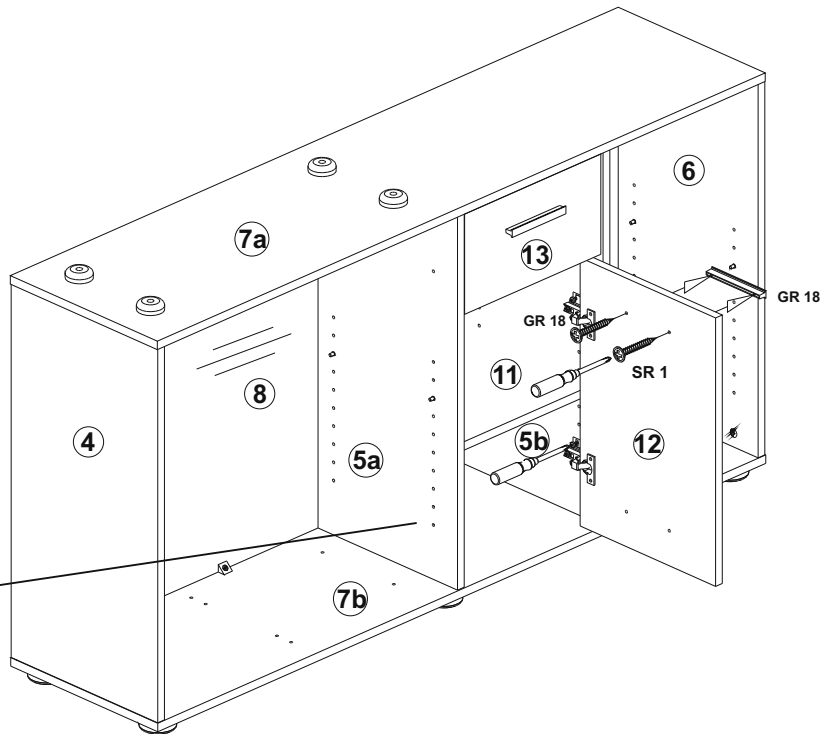

K3

©

 2 x AK2	 3,5x22 2 x SP10	 2 x AK1
--	---	--

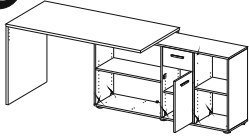

1

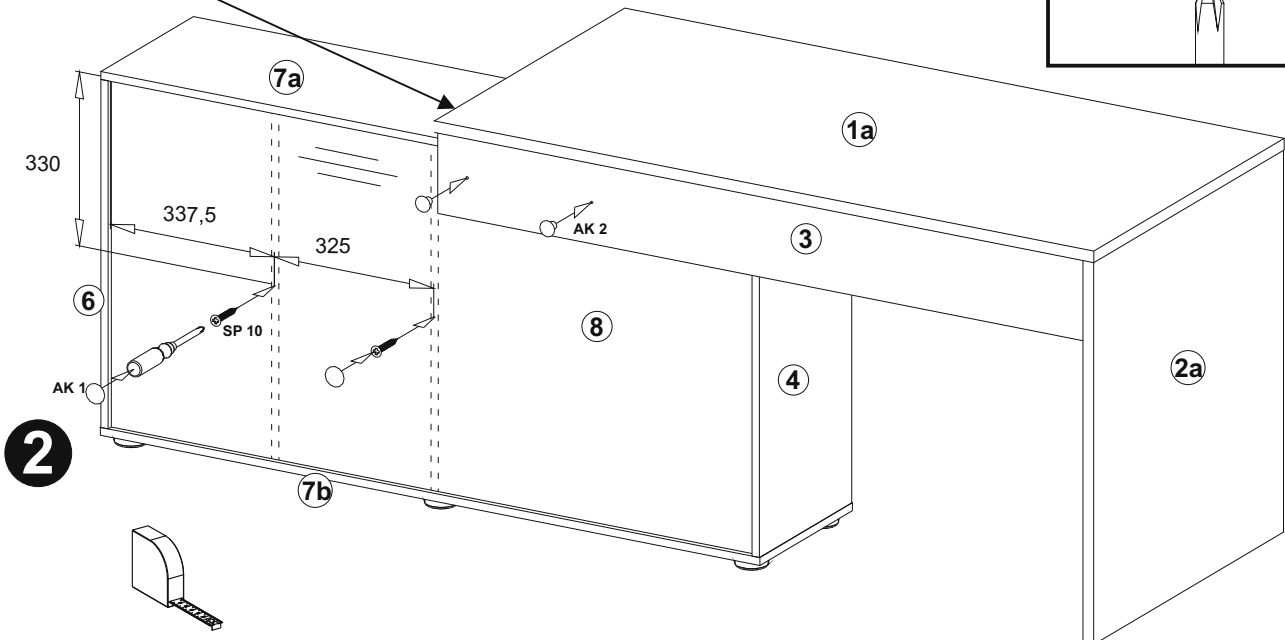
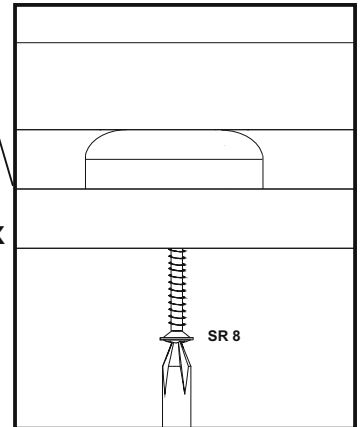
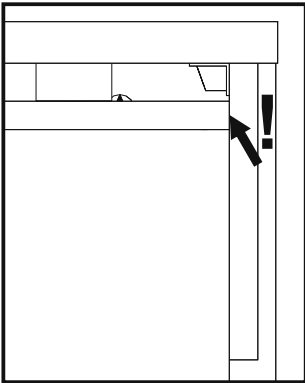
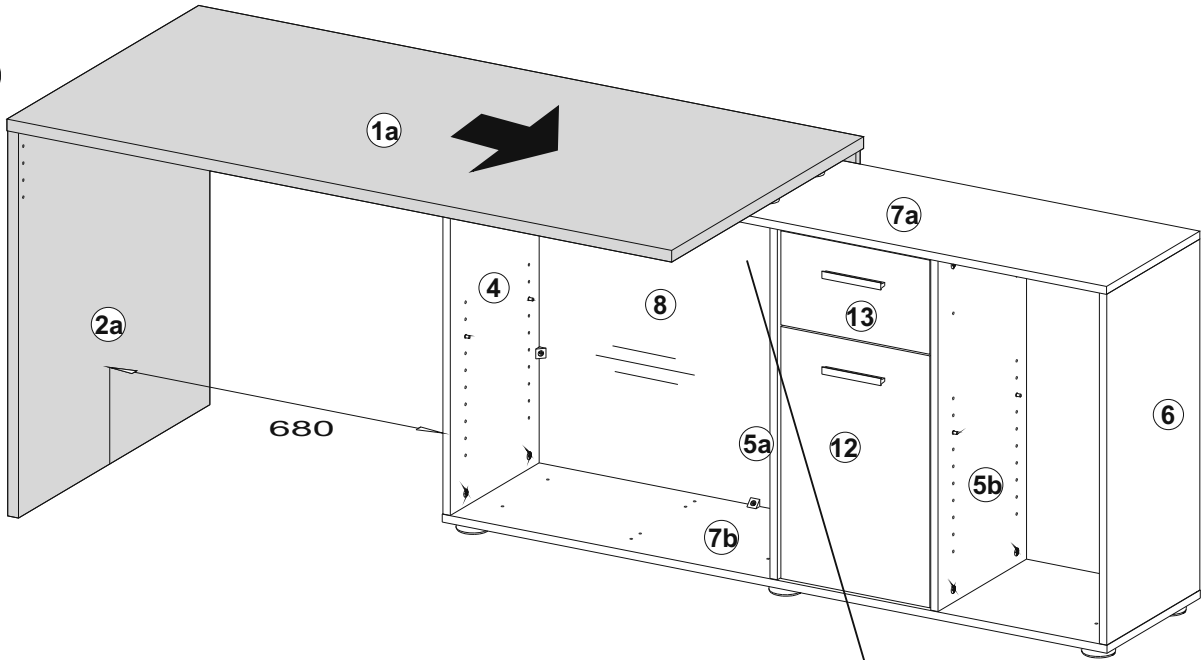

L3

G

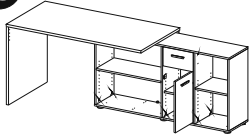

12x AK2

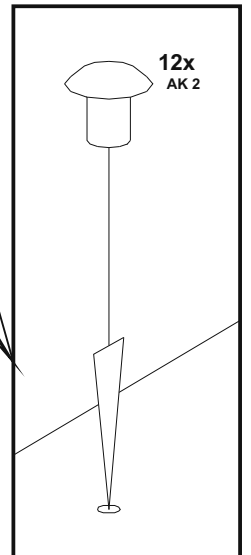
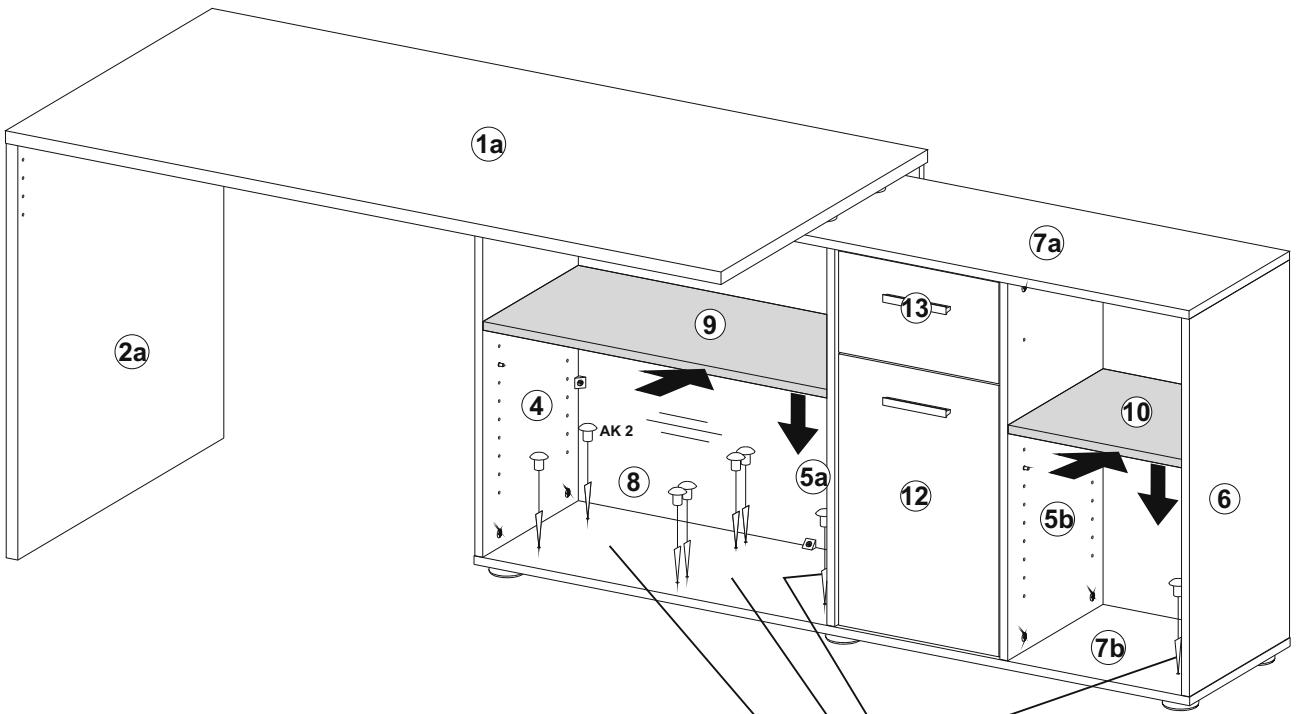

14

D

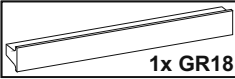
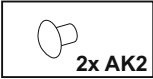
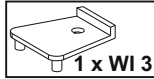

1

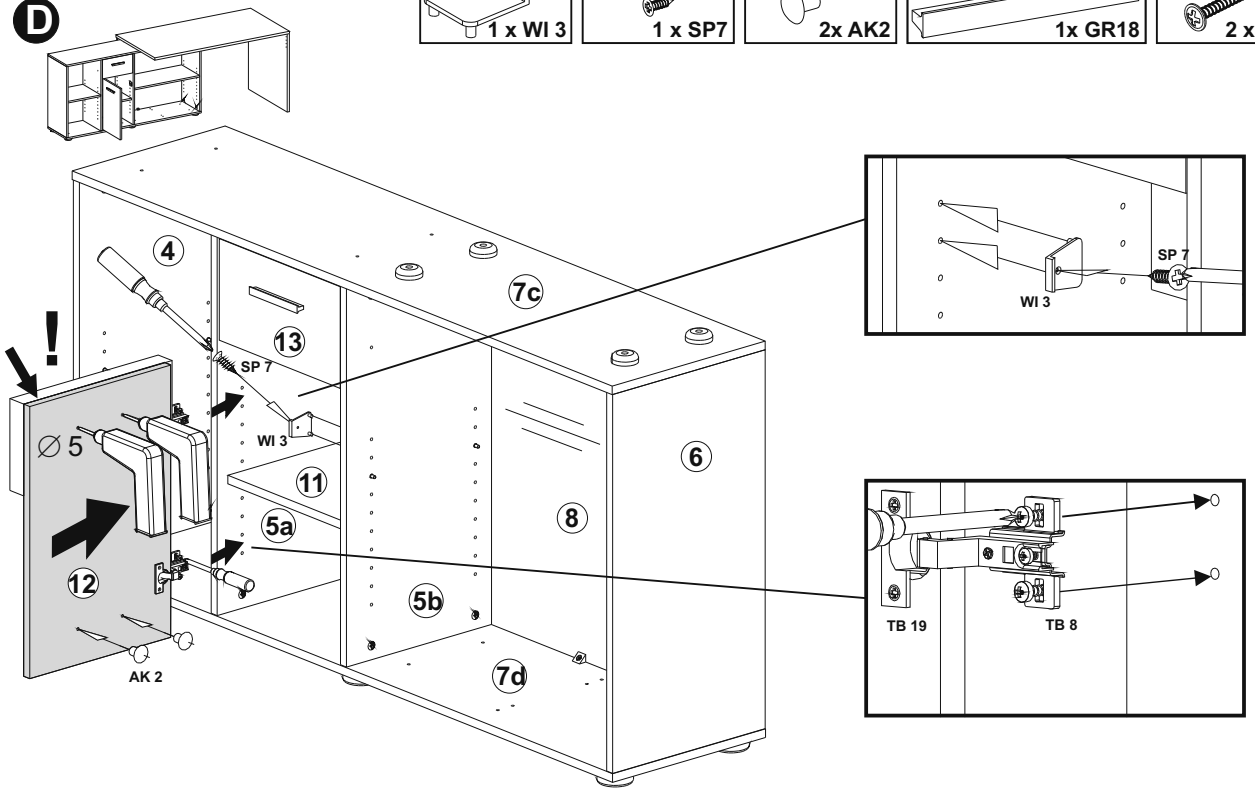

2

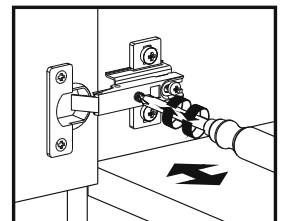
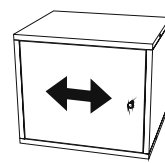
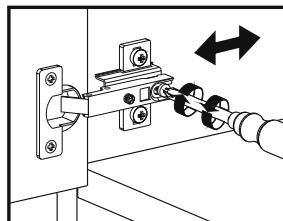
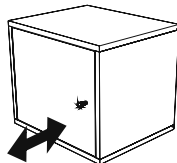
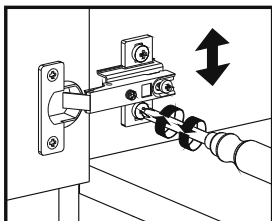
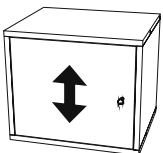
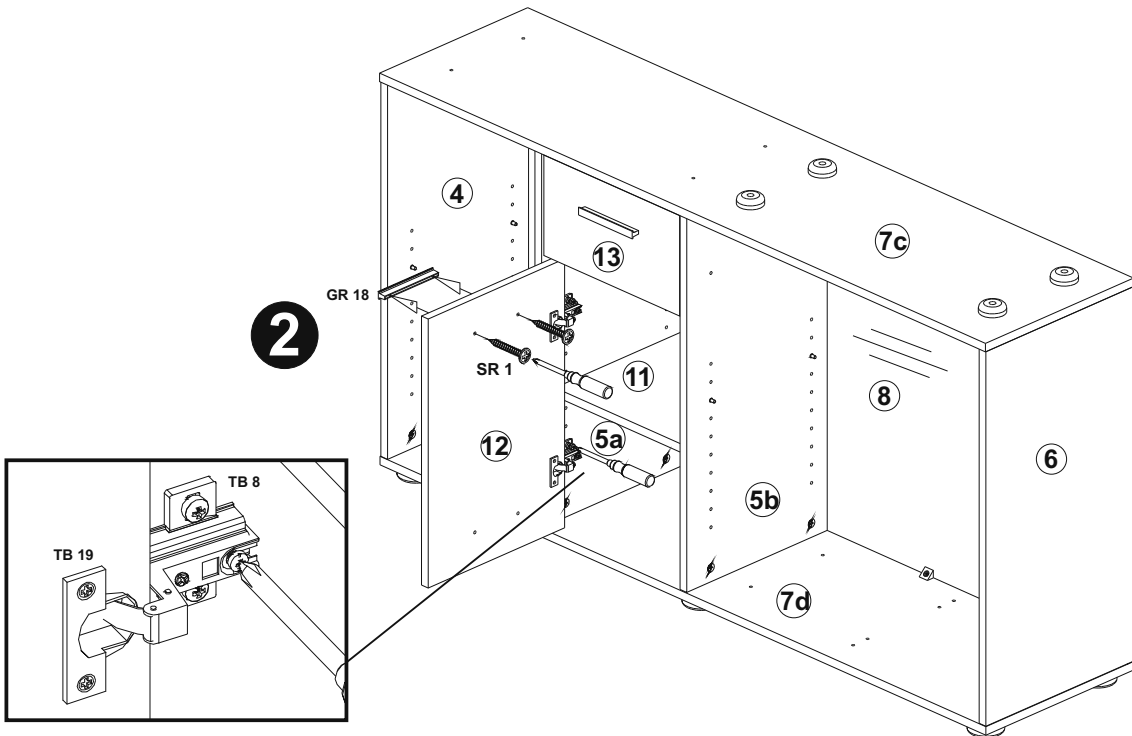

K4

D

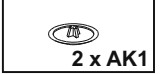
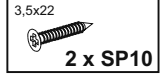
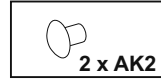
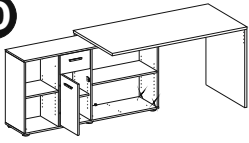

1

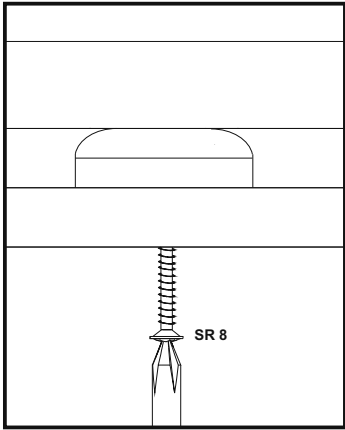
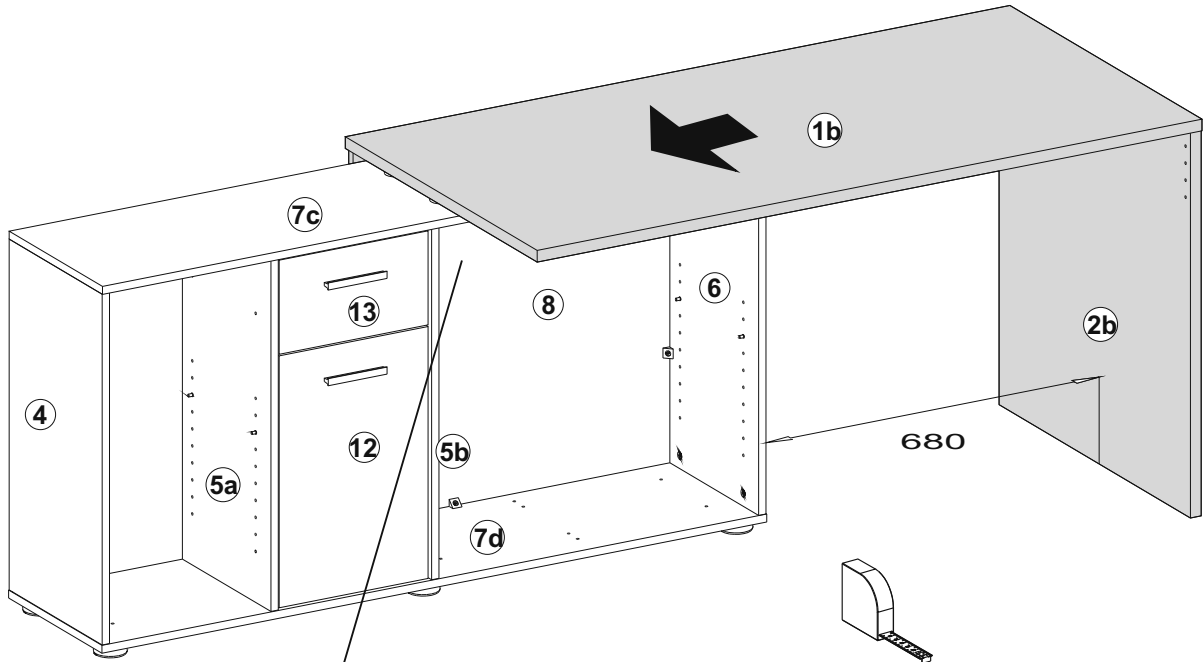

4x

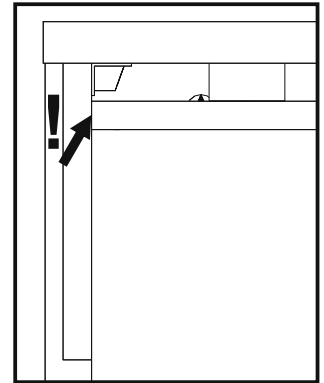

2

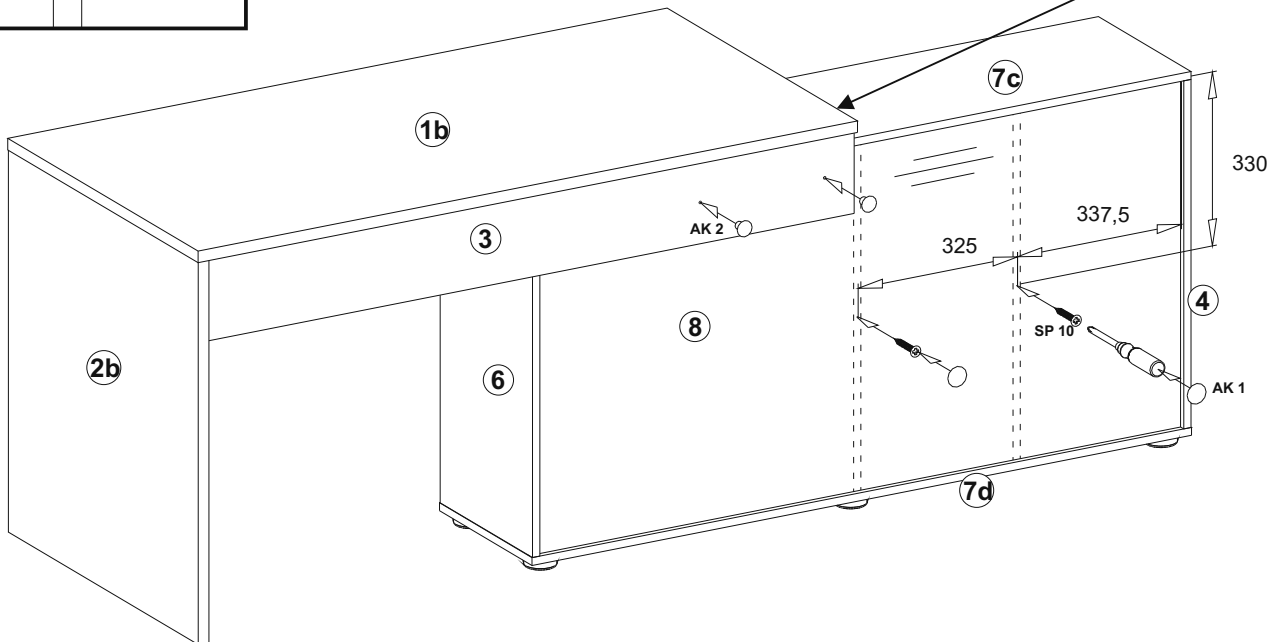

L4

D

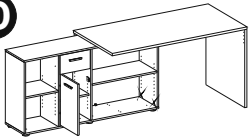

12x Ak2

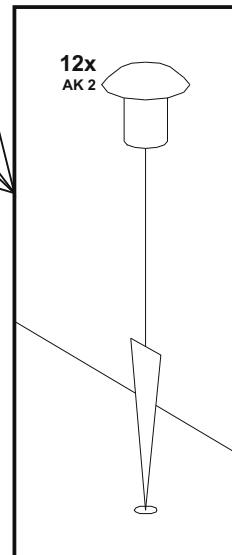
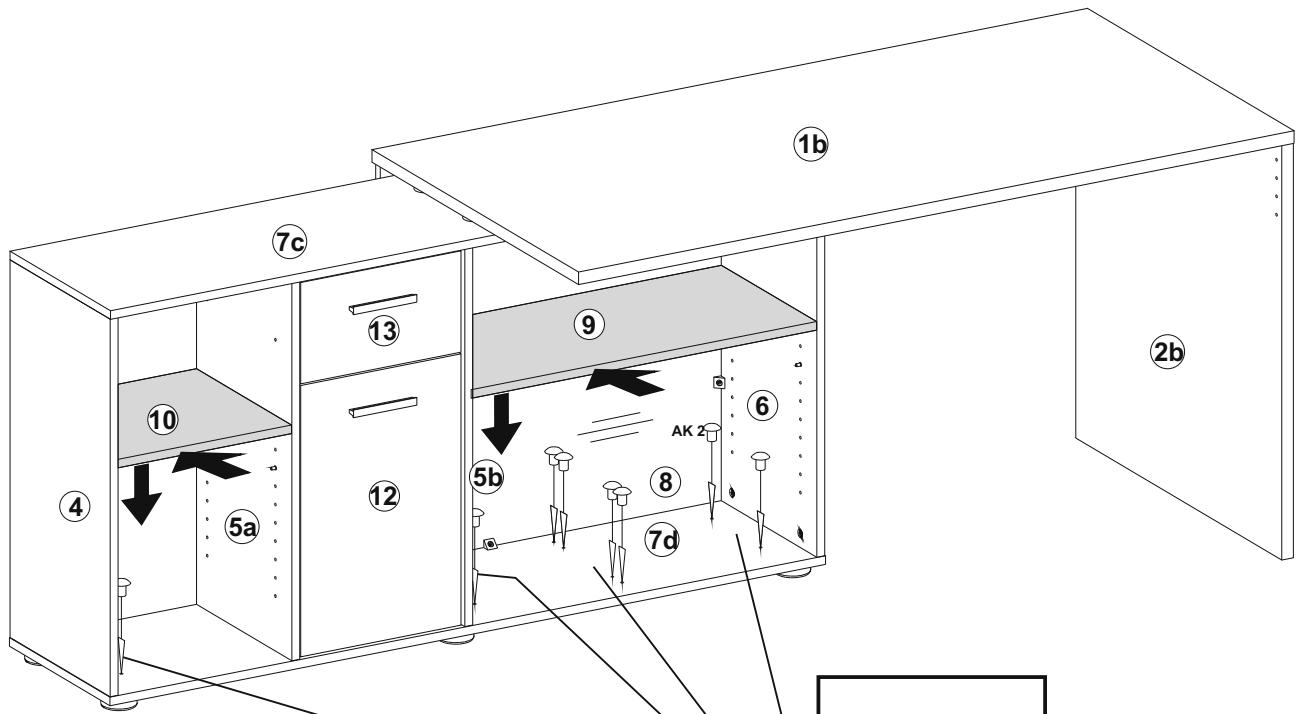

FMD®//furniture

FMD Möbel GmbH

Heidländer Weg 68
D-49201 Dissen a.T.W.

Tel. +49 5421 9448-44
Fax. +49 5421 9448-41
service@fmd-moebel.de
www.fmd-moebel.de