

**Gebrauchsanleitung PK-Nr. 2670**  
Instructions / Mode d'emploi / Gebruiksaanwijzing /  
инструкция по использованию / 使用说明



by PAIDI Möbel GmbH  
Hauptstraße 87  
97840 Hafenlohr  
Germany

**HILJA**  
**176 0154**

**ALISA**  
**176 4023**

**KRISTIN 2**  
**176 0158**

**LANA**  
**176 0119**

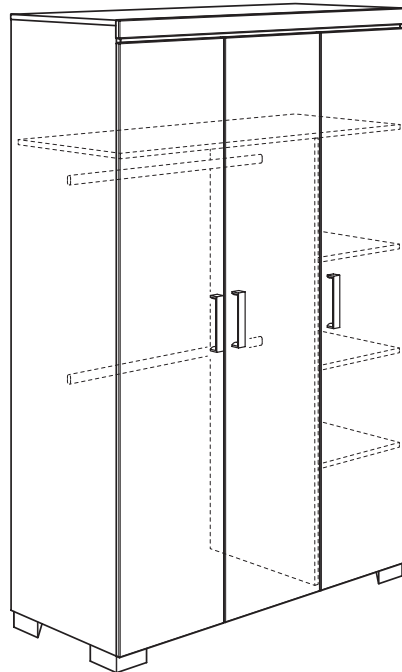

**LORIE**  
**176 0111**

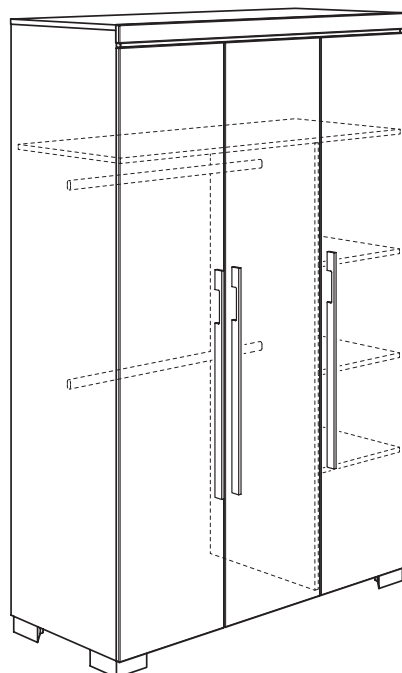



# Warnhinweis!

Warning! / Avertissement! / 警告!  
Waarschuwing! / Предупреждение!



by PAIDI Möbel GmbH  
Hauptstraße 87  
97840 Hafenlohr  
Germany

V..

Vorbereitung / Preparation / La  
préparation/ Voorbereiding /  
подготовка

M..

Montage / Assembly /  
Assemblage / Bijeenkomst /  
МОНТАЖ

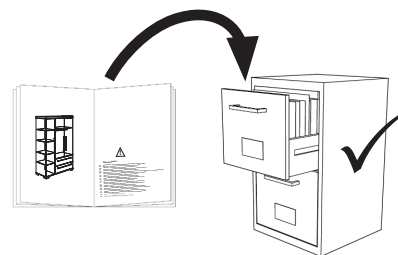

siehe PK-Nr. 2800



## Warnhinweis !

- DE Warnhinweis ! Beiliegende Wandbefestigungen müssen montiert werden !  
FR Attention ! Les fixations murales ci-jointes doivent être montées !  
GB Attention ! The enclosed wall mountings must be fitted !  
NL Let op ! De meegeleverde wandbevestigingen moeten worden gemonteerd !  
ES ¡Atención! Las fijaciones murales incluidas deben montarse  
GR Προσοχή ! Τα εξαρτήματα στήριξης που περιλαμβάνονται στη συσκευασία πρέπει να συναρμολογηθούν !  
IT Attenzione ! Occorre montare i fissaggi per attacco alla parete qui allegati !  
CZ Pozor ! Příložené úchytky musí být namontovány na stěnu !  
SL Pozor ! Namontirati je potrebno priložene elemente za pritrditev na zid !  
PL Uwaga ! Załączone zamocowania do ściany muszą być zamontowane !  
BG Внимание ! Приложениите закрепвания за стена трябва да бъдат монтирани !  
HR Pozor ! Priložena zidna pričvršćenja moraju biti montirana !  
LT Dėmesio ! Priedamas tvirtinimo prie sienos detales reikia sumontuoti !  
RU Внимание ! Обязательно используйте прилагаемые крепления стене !  
CN 注意 ! 附带的墙壁安装组件必须安装 !  
AR انتبه! لا بد من تركيب الأدوات المرفقة للتثبيت على الحائط!

- DE Pflegehinweis: Zum Reinigen der Oberflächen ein leicht-feuchtes Tuch oder ein handelsübliches Möbelpflegemittel verwenden.  
FR Indication sur l'entretien : pour nettoyer les surfaces, utiliser un chiffon légèrement humide ou un nettoyeur pour meubles en vente dans le commerce  
GB Caring for the... : In order to clean the surfaces please use a slightly damp cloth or commercially available furniture care product.  
NL Verzorgingsanwijzing: Voor het reinigen van de oppervlakken een licht vochtig doek of een gebruikelijk meubelschoonmaakmiddel gebruiken.  
ES Recomendaciones de cuidado: Para limpiar las superficies del mueble debe usar un trapo humedecido o un producto de limpieza de muebles comercial.  
GR Οδηγίες περιποίησης: Για το καθάρισμα των επιφανειών να χρησιμοποιείτε ένα ελαφρά νοτισμένο πανάκι ή λούστρο επίπλων.  
IT Indicazione per pulizia e cura: Per la pulizia delle superfici utilizzate un panno leggermente umido o un normale prodotto per la cura dei mobili.  
CZ Pokyny k čištění: Na čištění povrchu použijte pouze navlhčený kousek látky nebo běžný prostředek na ošetřování nábytku.  
SL Navodilo za nego: Za čiščenje površin uporabljajte malo vlažno cunjo ali trgovaško običajno sredstvo za nego pohištva.  
PL Wskazówka pielęgnacyjna: do czyszczenia powierzchni stosować lekko wilgotną ściereczkę lub zwykły środek do pielęgnacji mebli.  
BG Указание за поддръжане: Използвайте леко навлажнена кърпа или обикновен препарат за поддръжане на мебели, за да почистите повърхностите.  
HR Upute za njegu: Za čišćenje površina upotrijebite jednu lako navlaženu krpu i trgovačko uobičajeno sredstvo za njegu namještaja.  
LT Rekomendacija priežiūrai: Paviršius valykite drėgna pašluoste arba parduotuvėse įsigytomis baldų priežiūros priemonėmis.  
RU Рекомендации по уходу: для очистки поверхностей используйте слегка влажную тряпку или обычное средство по уходу за мебелью.  
CN 保养说明: 清洁表面只需用稍微潮湿的布或普通的家具清洁剂即可。

# Beschläge

Fittings / Raccords / Hulpstukken /  
Фурнитура / 配件



by PAIDI Möbel GmbH  
Hauptstraße 87  
97840 Hafenlohr  
Germany

1:1  
DIN A4

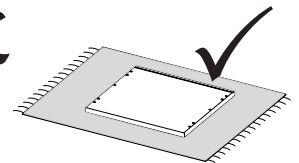
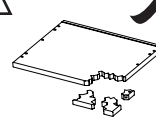
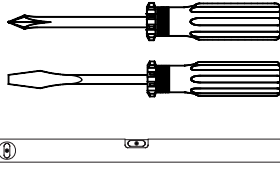
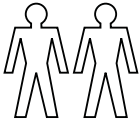

Tür Außen  
door outside  
porte extérieure  
deur naar buiten  
Puerta afuera

Tür Mitte  
centre door  
Porte du milieu  
midden deur  
Puerta central

Progr. HILJA  
Progr. ALISA  
Progr. KRISTIN 2  
Progr. LANA

Progr. LORIE

<b>A</b>  ø8 x 35 20x 681 0702	<b>B</b>  20x 681 0859	<b>C</b>  4x 681 1647	<b>D</b>  3,5 x 15 22x 681 2639	<b>E</b>  6x 681 2640	<b>F</b>  3x 681 2642	<b>G</b>  4x 681 0351	<b>H</b>  4x 681 0757	<b>I</b>  4,0 x 30 10x 681 4910	<b>I</b>  4,0 x 30 19x 681 4910
<b>J</b>  16x 681 7164	<b>K</b> Progr. HILJA + ALISA + LORIE + KRISTIN 2  4x 681 8052 SILBER		<b>K</b> Progr. LANA  4x 681 8480 SCHIEFERGRAU			<b>L</b>  4,0 x 25 4x 681 4896	<b>M</b>  1x 681 0868	<b>N</b>  67 mm 1x 681 0864	
<b>O</b> Tür Außen door outside porte extérieure deur naar buiten Puerta afuera  6x 681 2630			<b>P</b> Tür Mitte centre door Porte du milieu midden deur Puerta central  3x 681 2631			<b>R</b>  12x 681 0350	<b>S</b>  3,0 x 20 16x 681 4914	<b>T</b>  14x 681 2498	
<b>U</b> Progr. HILJA + ALISA + KRISTIN 2  3x 681 8051 SILBER			<b>U</b> Progr. LANA  3x 681 8479 SCHIEFERGRAU			<b>U</b> Progr. LORIE  Griffstange Länge: 700mm  3x 681 8442 SILBER			



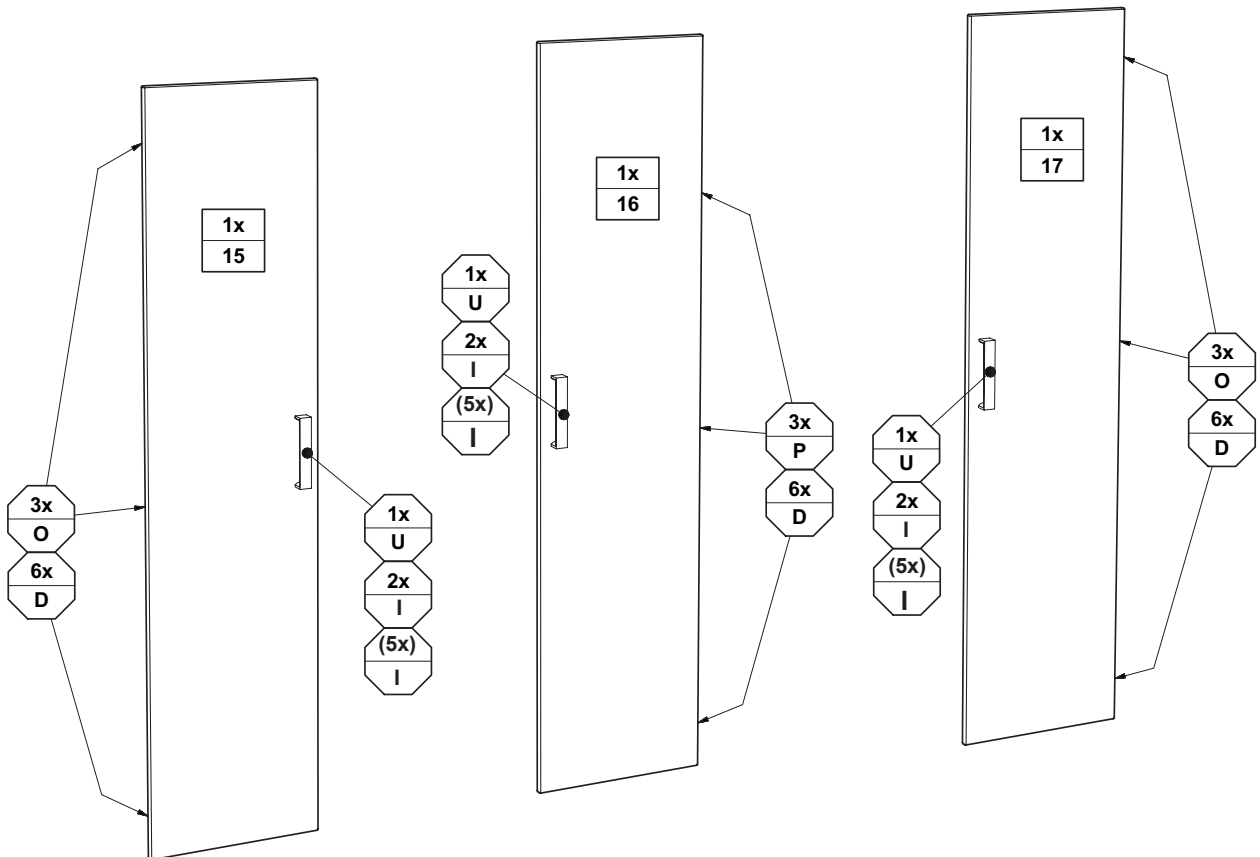
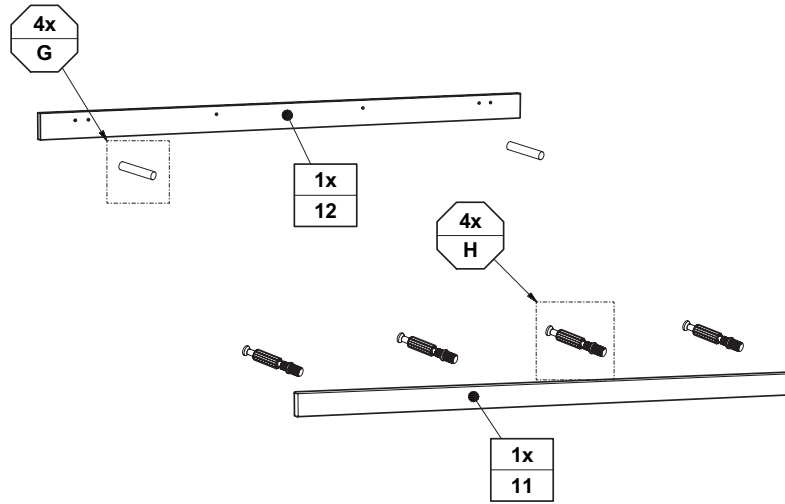
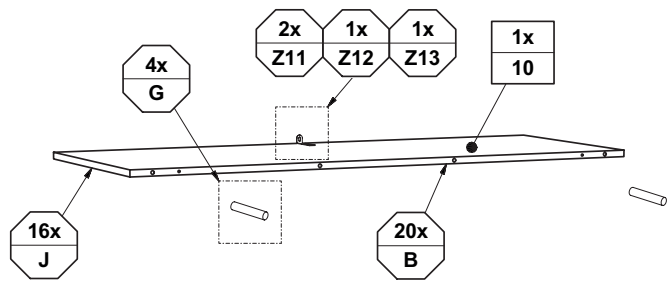

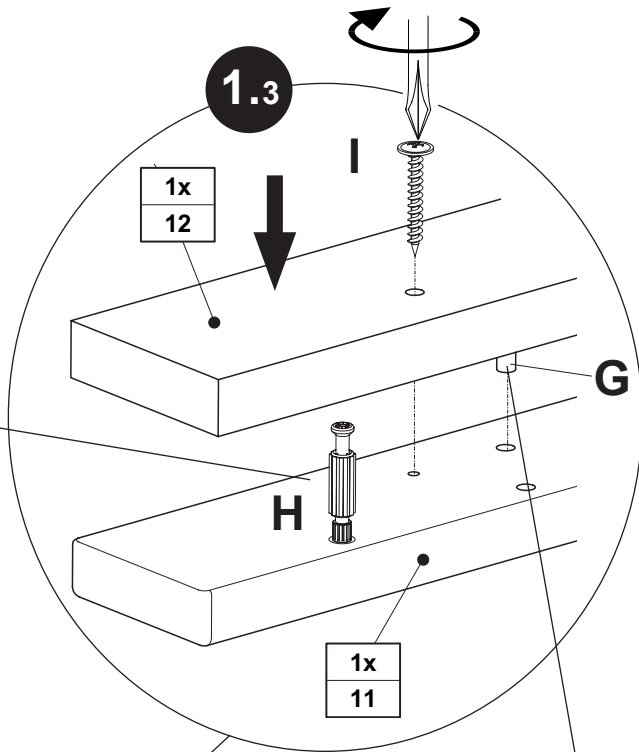
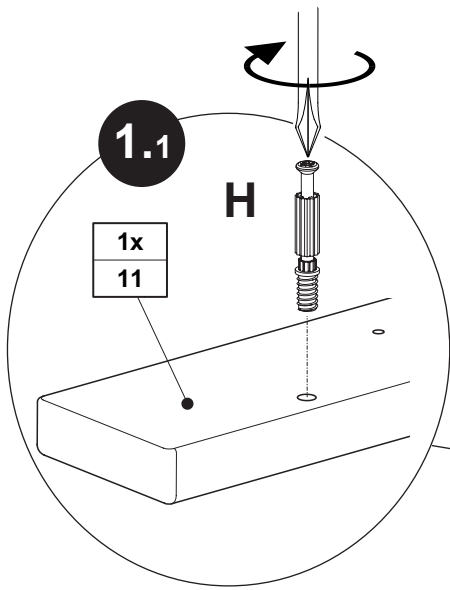
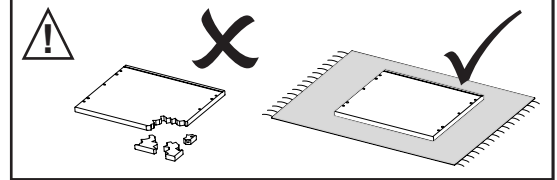

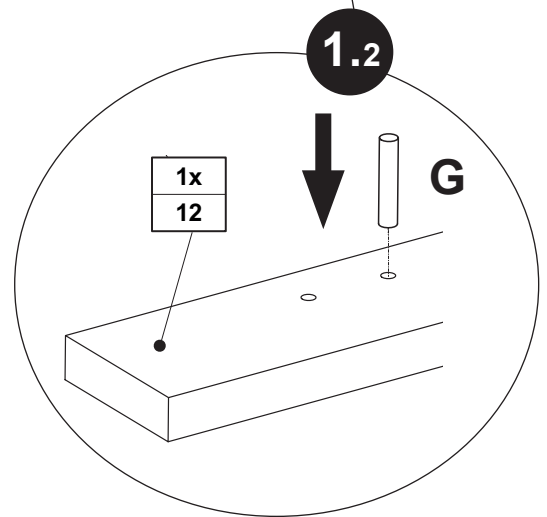
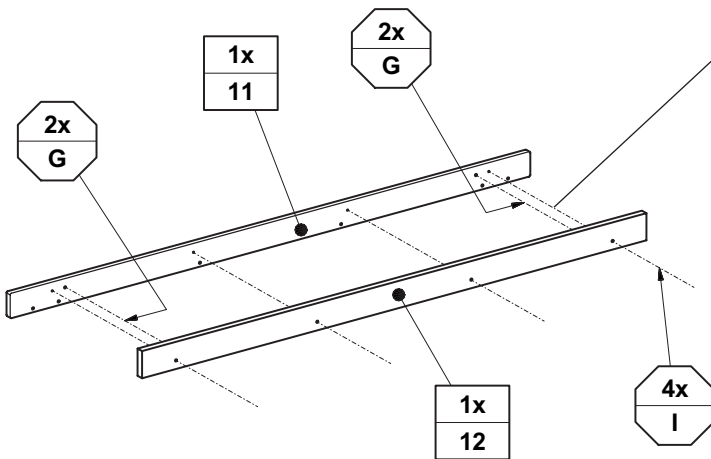

**V1.1**



G	H	I
		
2x 681 0351	4x 681 0757	4,0 x 30 4x 681 4910

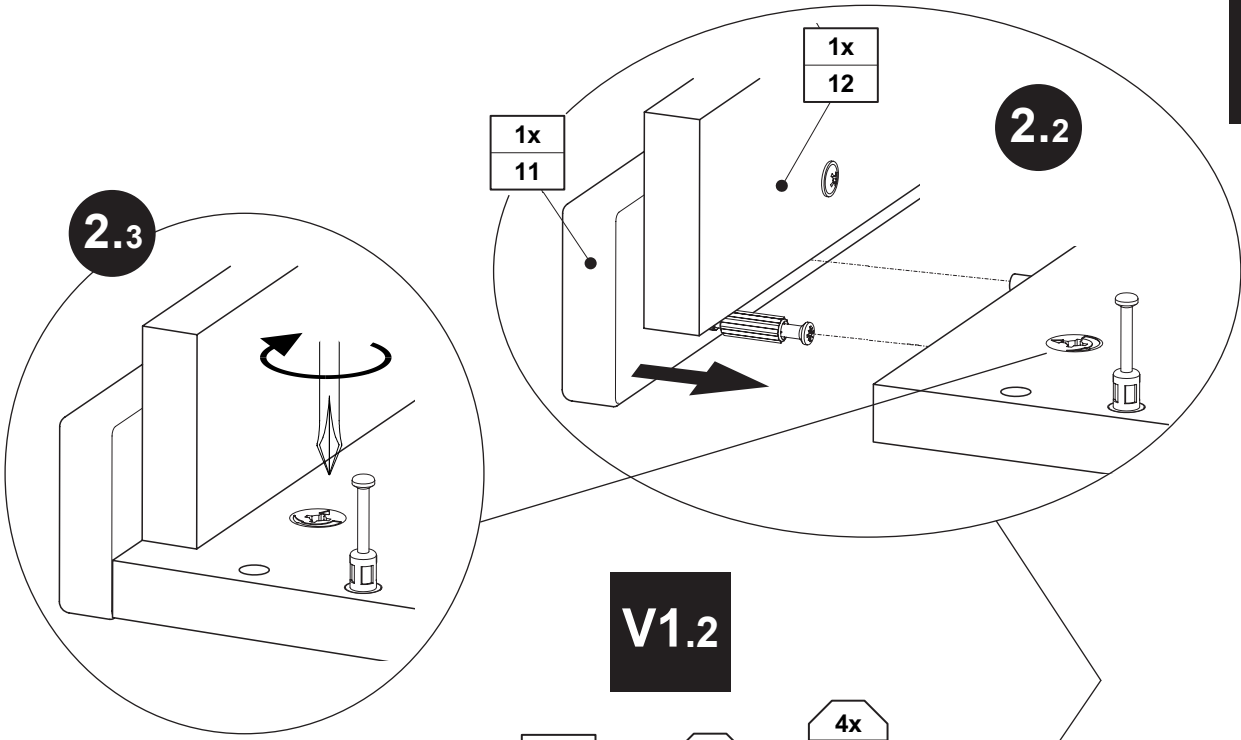

## V1.2

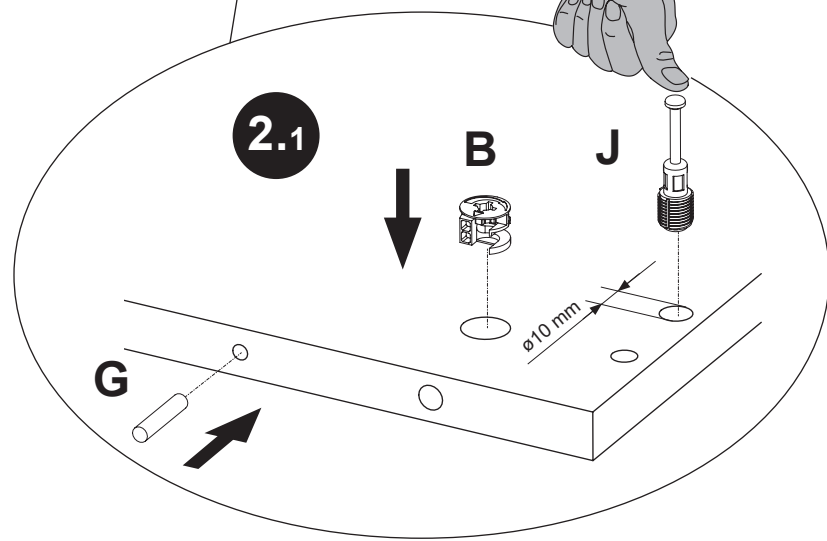
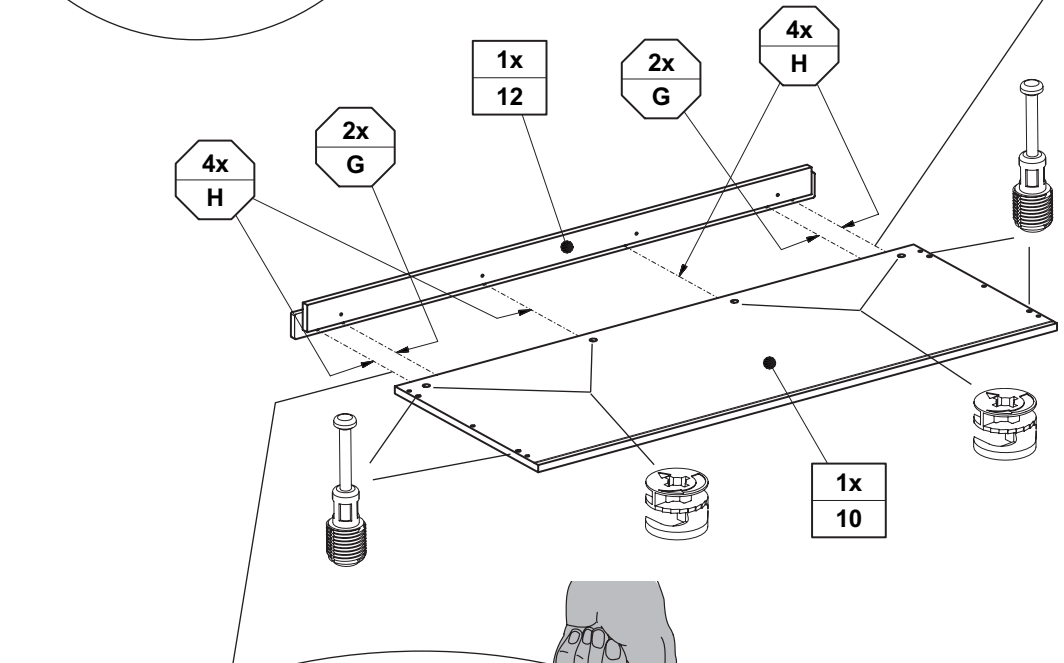

B	G	J
4x 681 0859	2x 681 0351	4x 681 7164

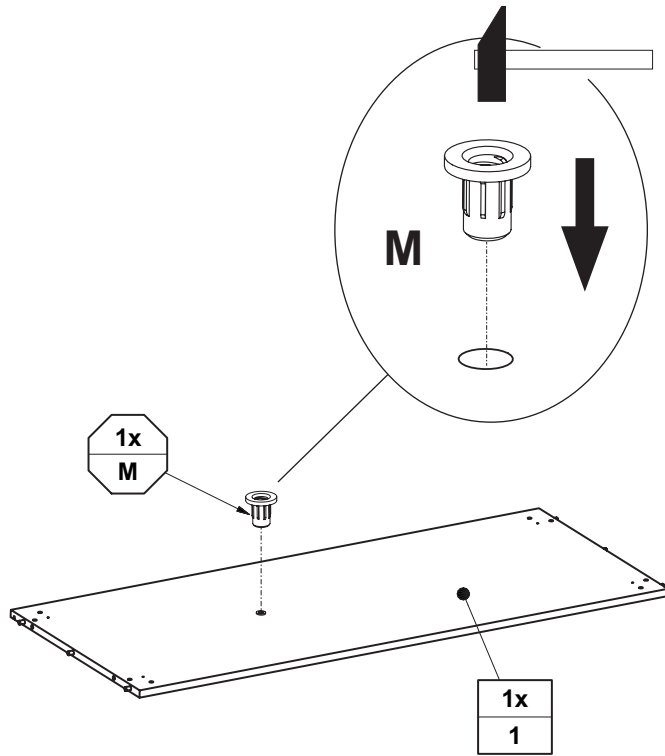

# V2

## V2.1

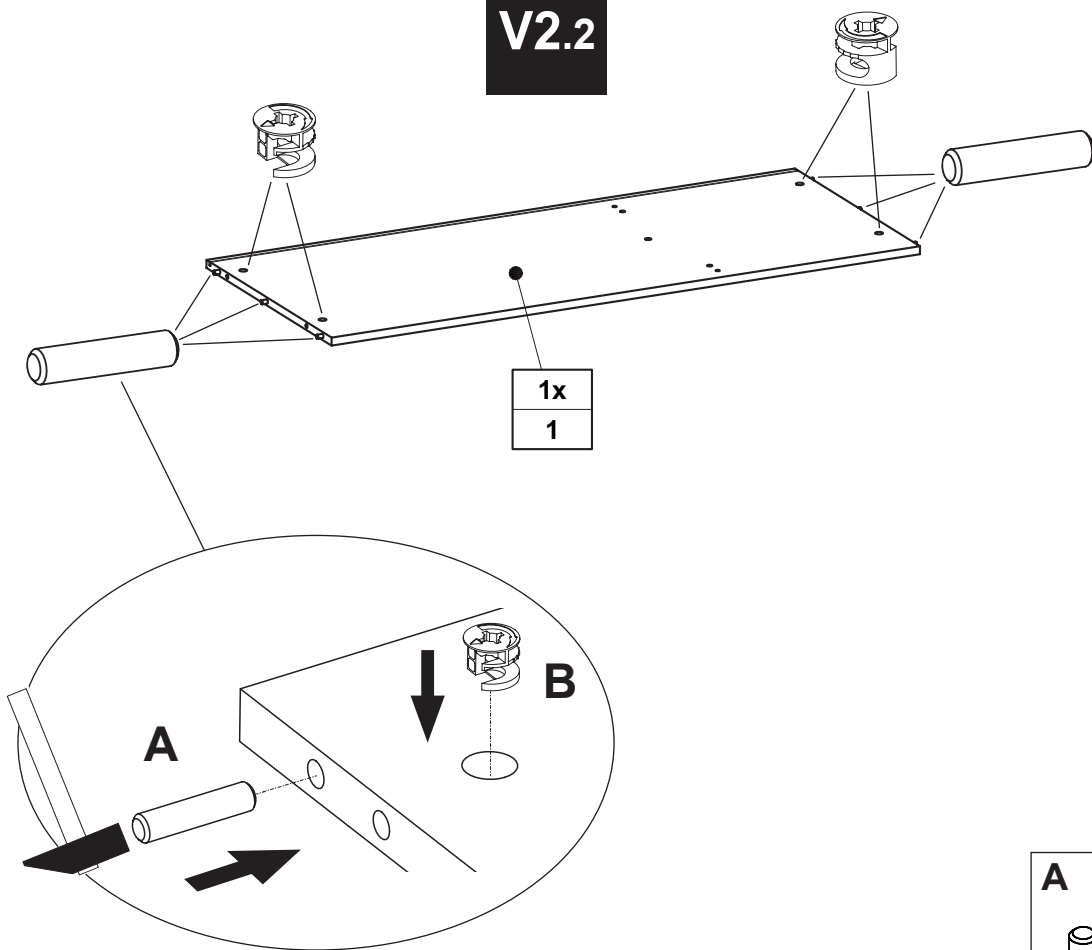

## V2.2



A	B
	
ø8 x 35 6x 681 0702	4x 681 0859



4x  
K

4x  
L

1x  
N

1x  
1

V2.3

3.2

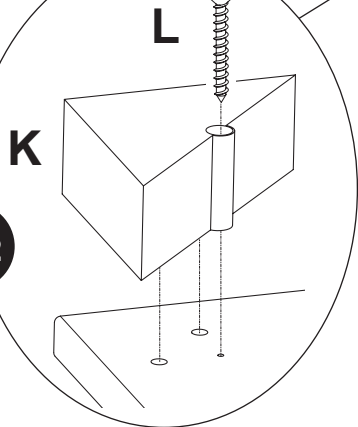

3.1

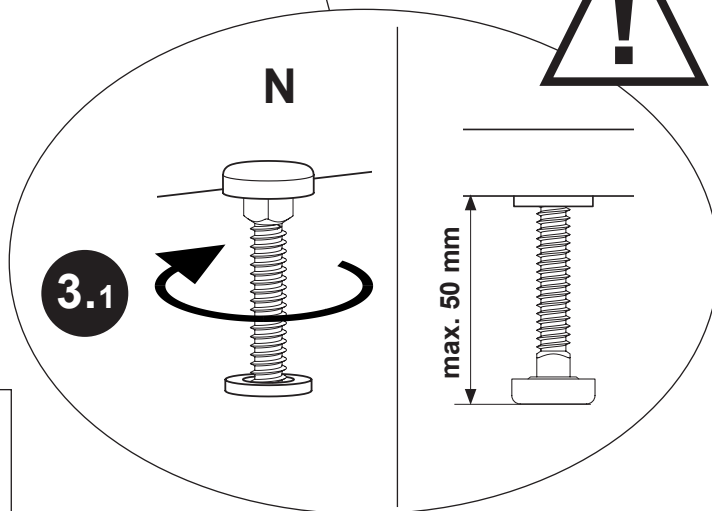

K

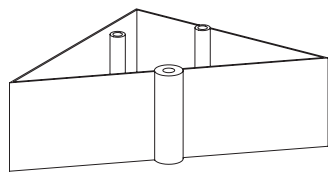

4x  
681 8052 / 681 8480

L

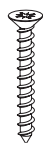

4,0 x 25  
4x  
681 4896

N



67 mm  
1x  
681 0864

V2.4



Höhenverstellung !!

Height adjustment !  
Réglage de la hauteur !  
Hoogteverstelling !  
Регулировка высоты !  
高度調整!

ø10 mm

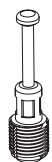

J

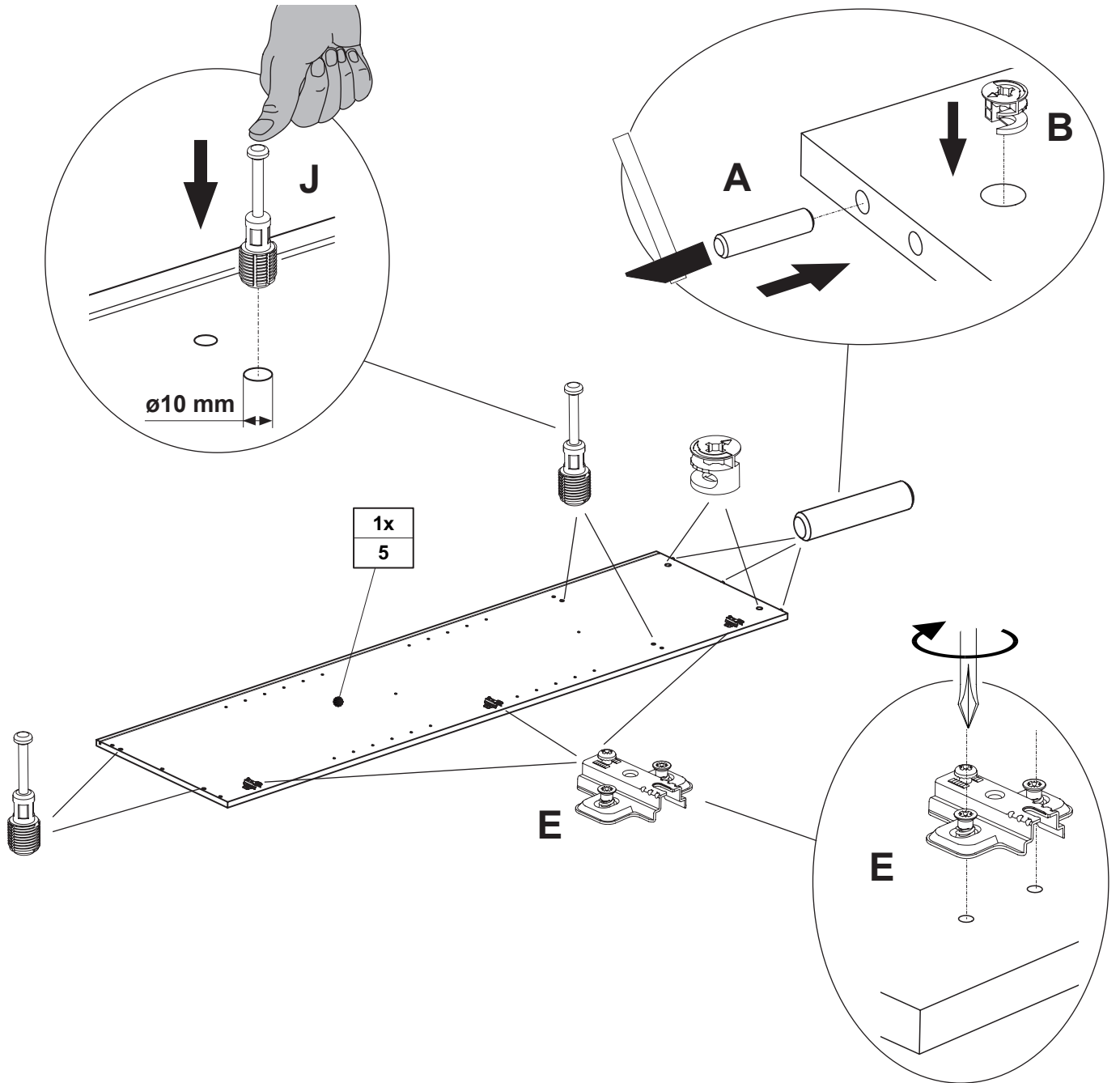

2x  
681 7164

1x  
1

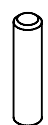

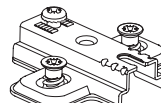
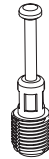

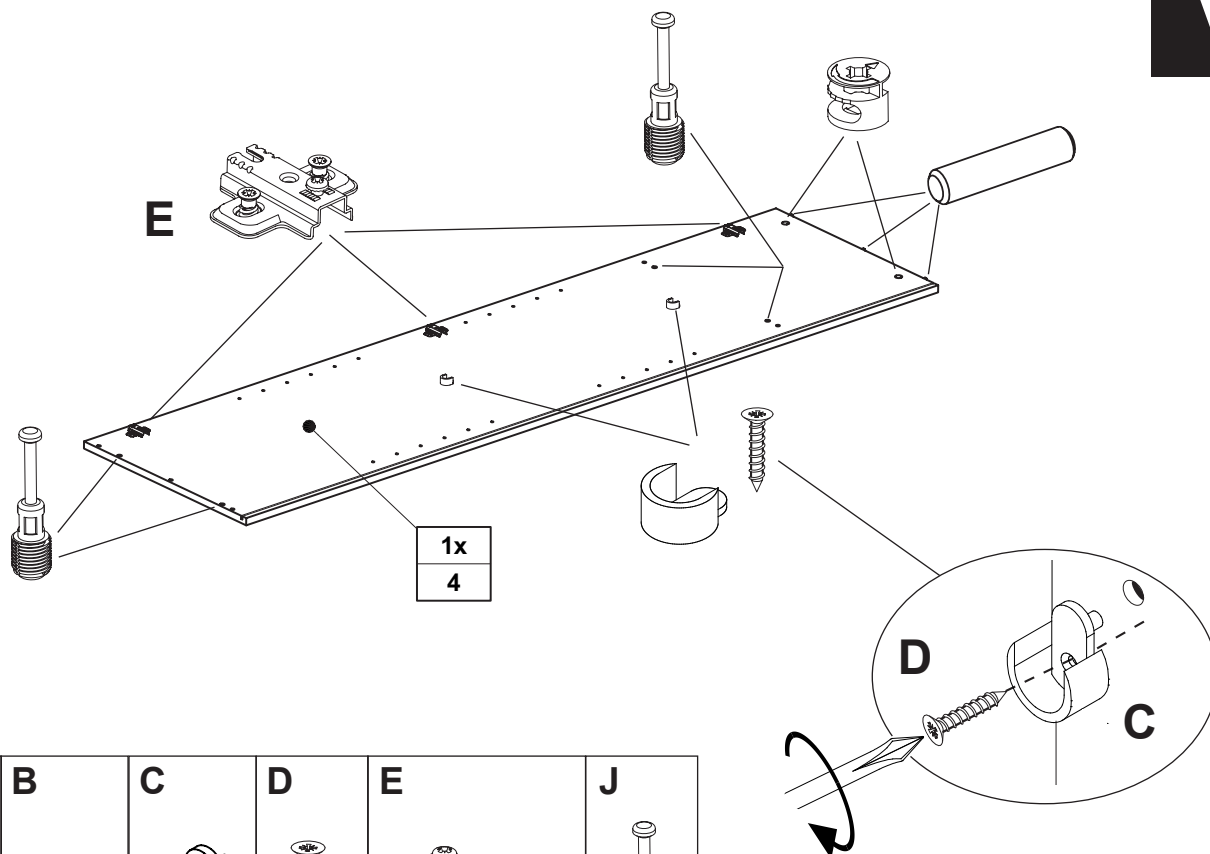
<p><b>A</b></p>  <p>ø8 x 35 3x 681 0702</p>	<p><b>B</b></p>  <p>2x 681 0859</p>	<p><b>E</b></p>  <p>3x 681 2640</p>	<p><b>J</b></p>  <p>4x 681 7164</p>
---	--	--	--

**V4**

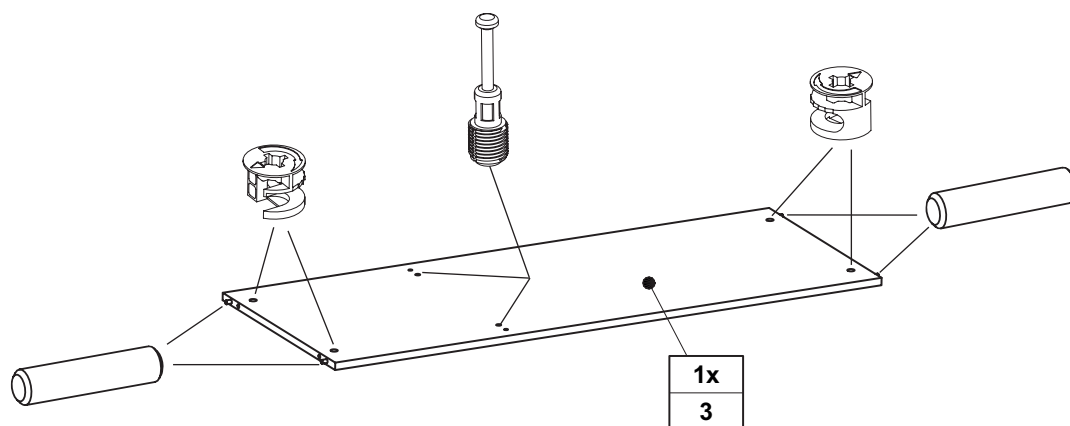
A	B	C	D	E	J
ø8 x 35 3x 681 0702	2x 681 0859	2x 681 1647	3,5 x 15 2x 681 2639	3x 681 2640	4x 681 7164

**V5**

A	B	J
ø8 x 35 4x 681 0702	4x 681 0859	2x 681 7164

A	B
	
ø8 x 35 4x 681 0702	4x 681 0859

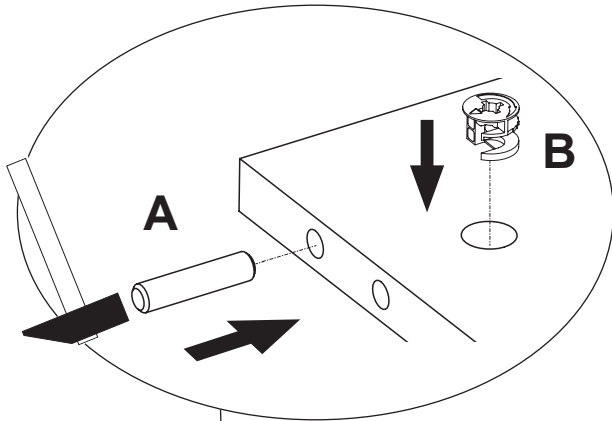

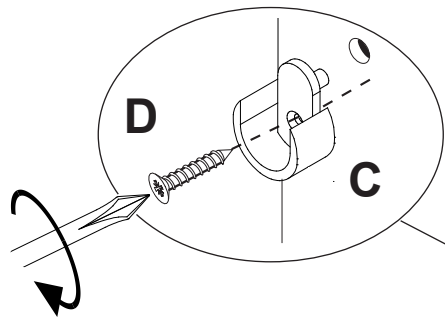
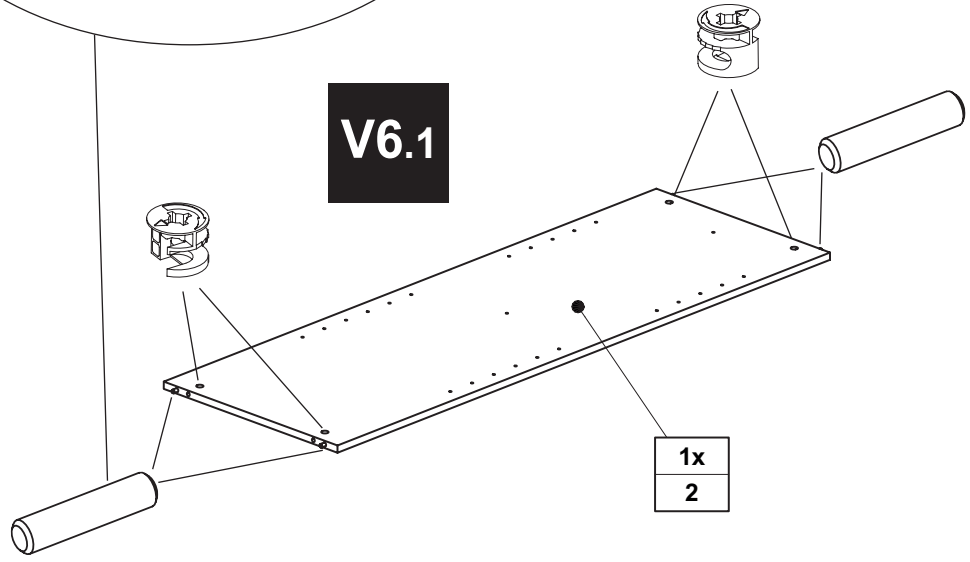

## V6.1

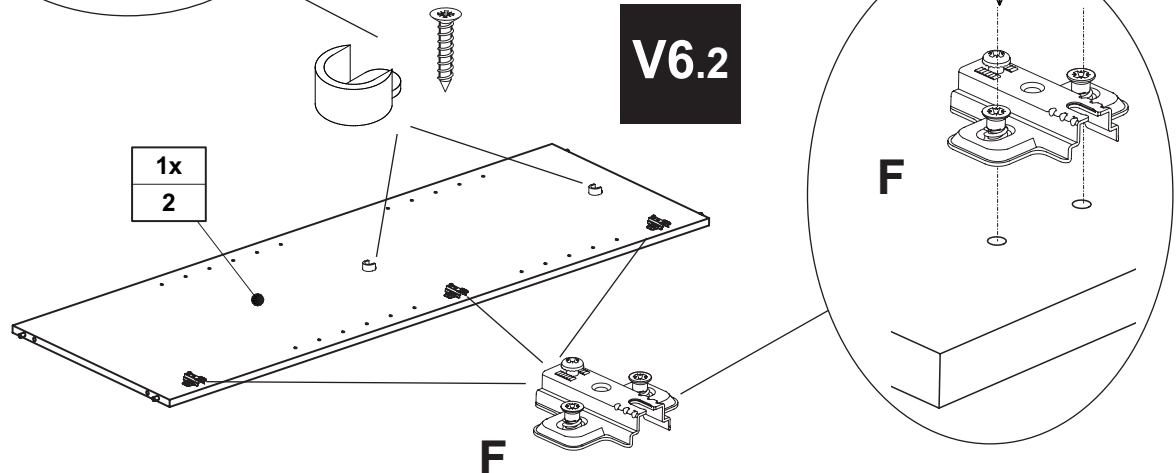

## V6.2

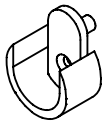

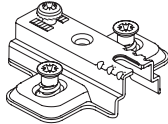

C	D	F
		
2x 681 1647	3,5 x 15 2x 681 2639	3x 681 2642

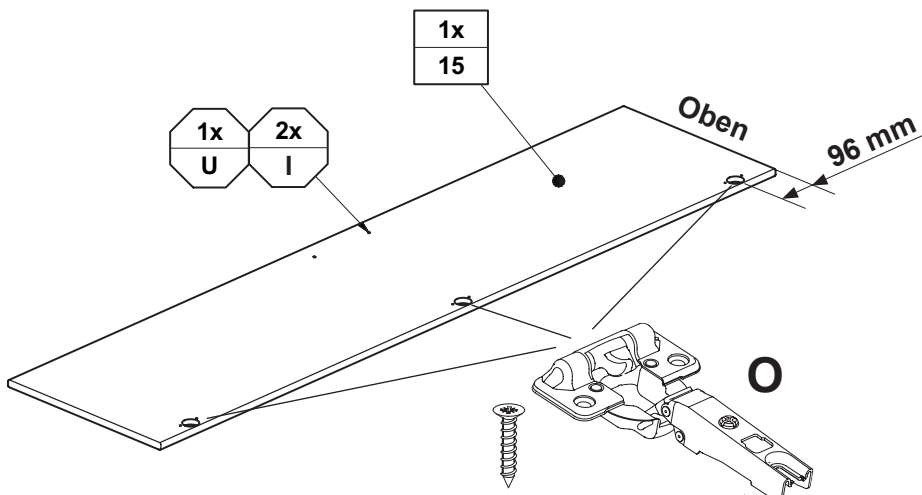
V7



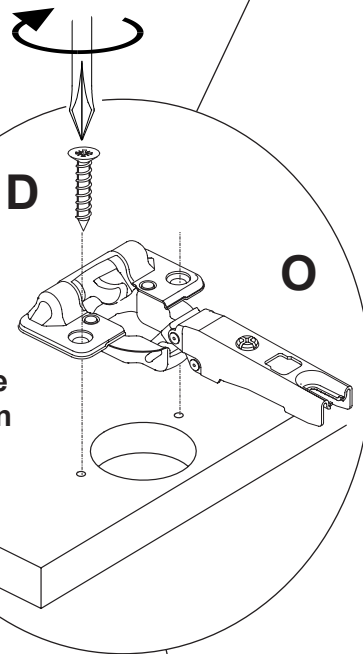

Tür Außen  
door outside  
porte extérieure  
deur naar buiten  
Puerta afuera

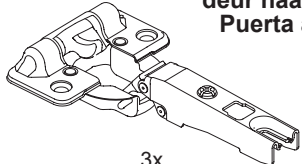

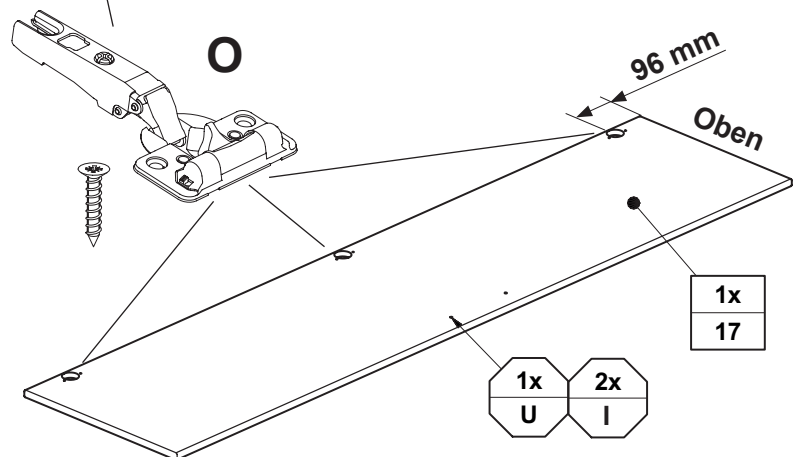

<p><b>D</b></p>  <p>3,5 x 15 6x 681 2639</p>	<p><b>O</b></p>  <p>Tür Außen door outside porte extérieure deur naar buiten Puerta afuera</p> <p>3x 681 2630</p>
---	---

V8

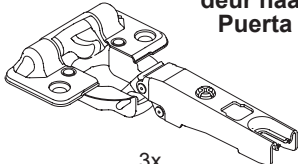

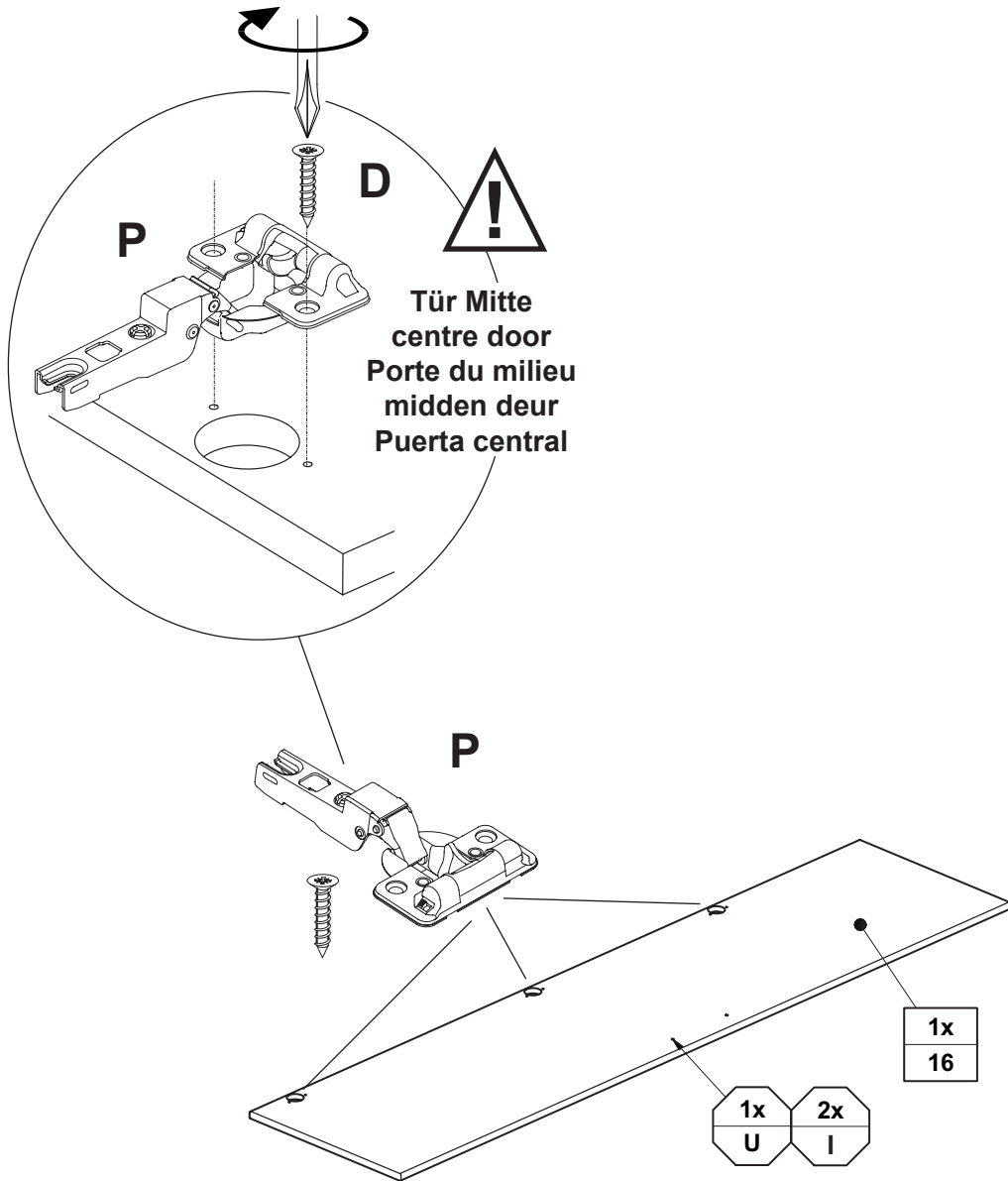
<p><b>D</b></p>  <p>3,5 x 15 6x 681 2639</p>	<p><b>O</b></p>  <p>Tür Außen door outside porte extérieure deur naar buiten Puerta afuera</p> <p>3x 681 2630</p>
---	--

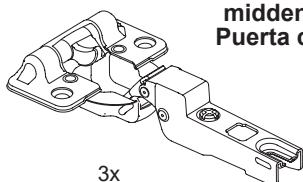

<p><b>D</b></p>  <p>3,5 x 15 6x 681 2639</p>	<p><b>P</b></p>  <p><b>Tür Mitte</b>  <b>centre door</b>  <b>Porte du milieu</b>  <b>midden deur</b>  <b>Puerta central</b></p> <p>3x 681 2631</p>
---	---



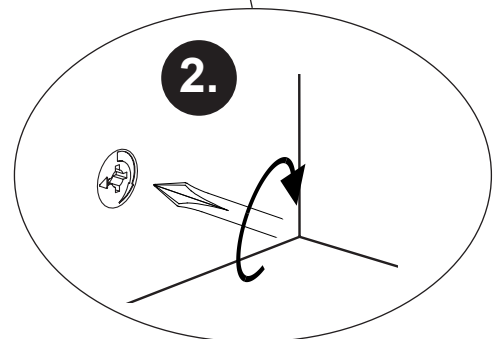
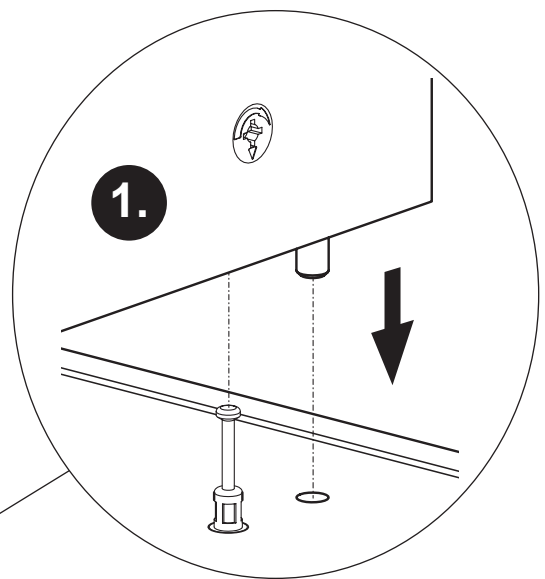
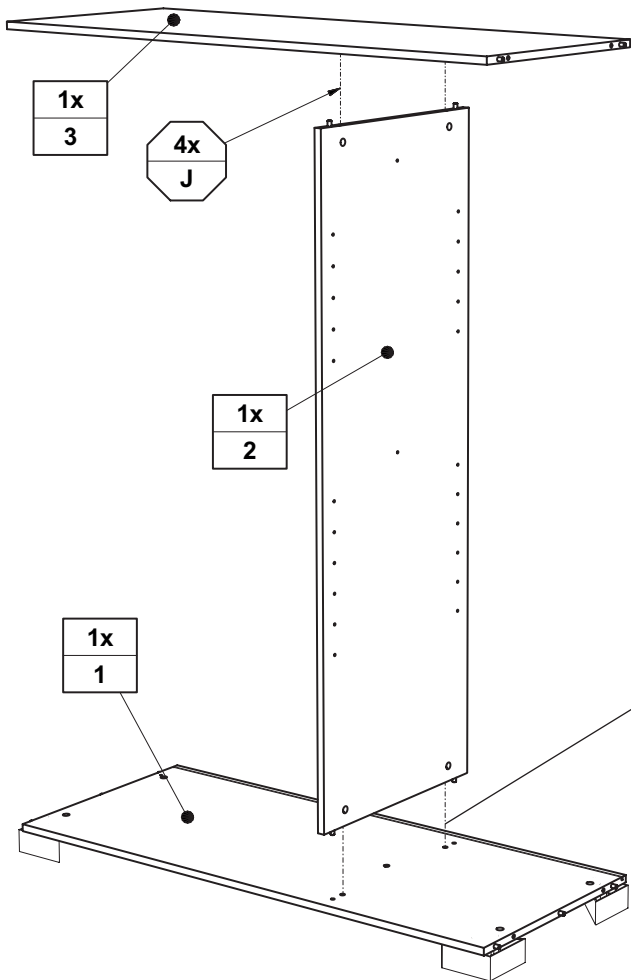



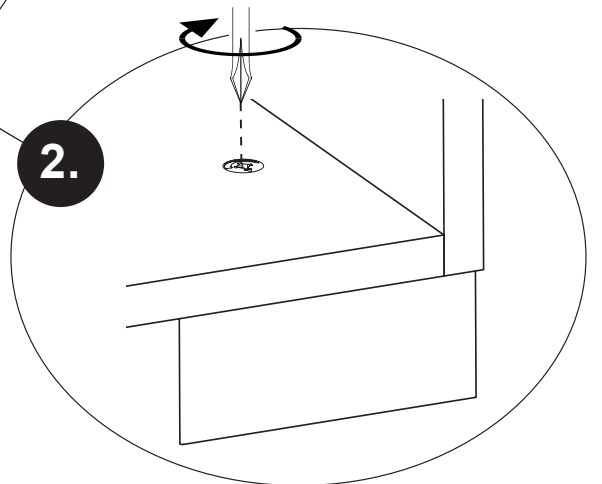
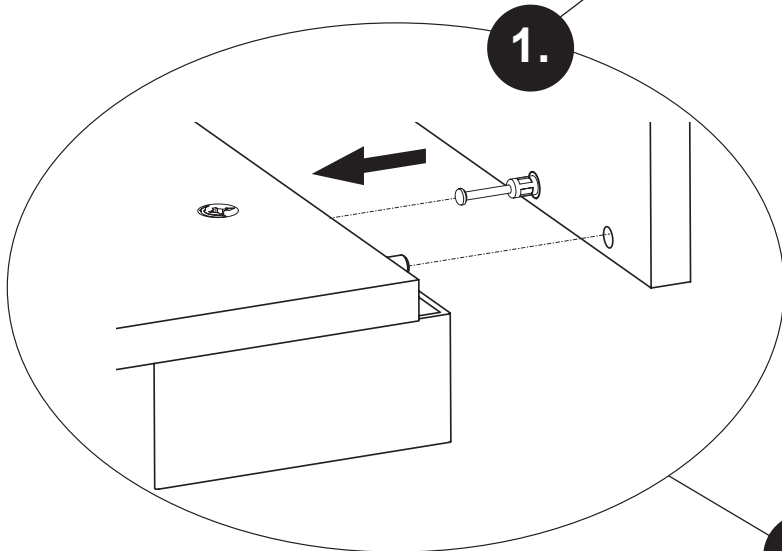
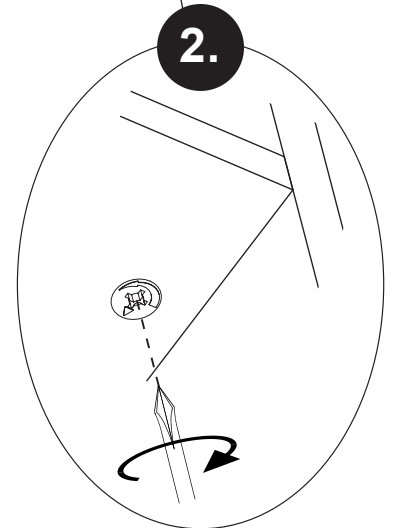
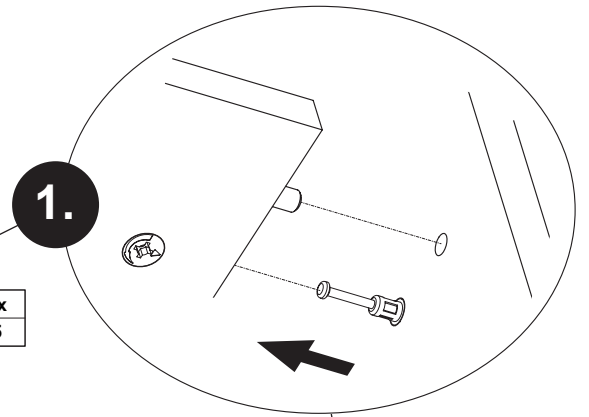
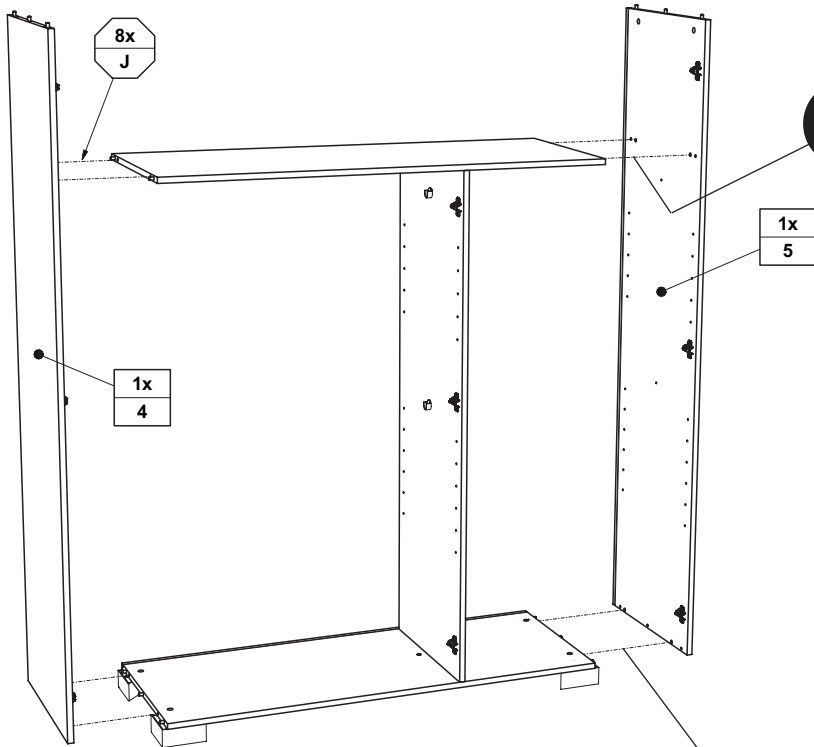

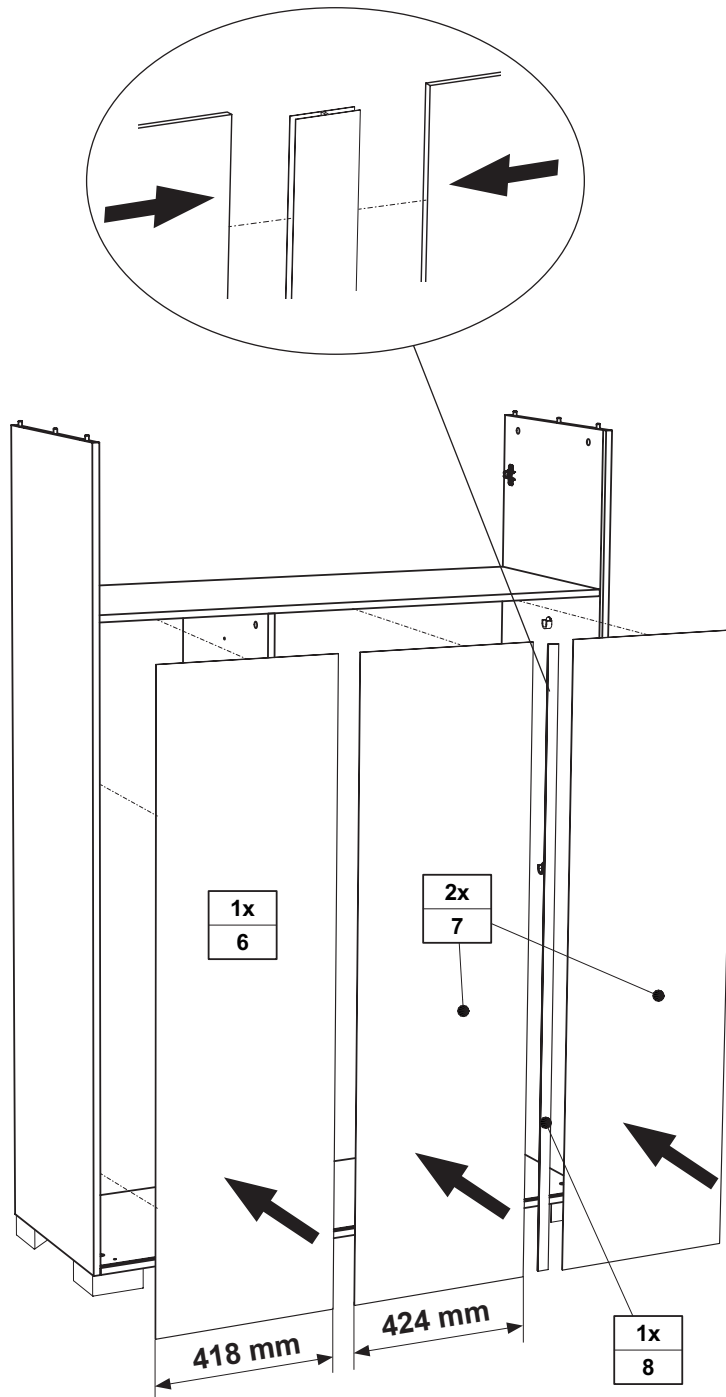

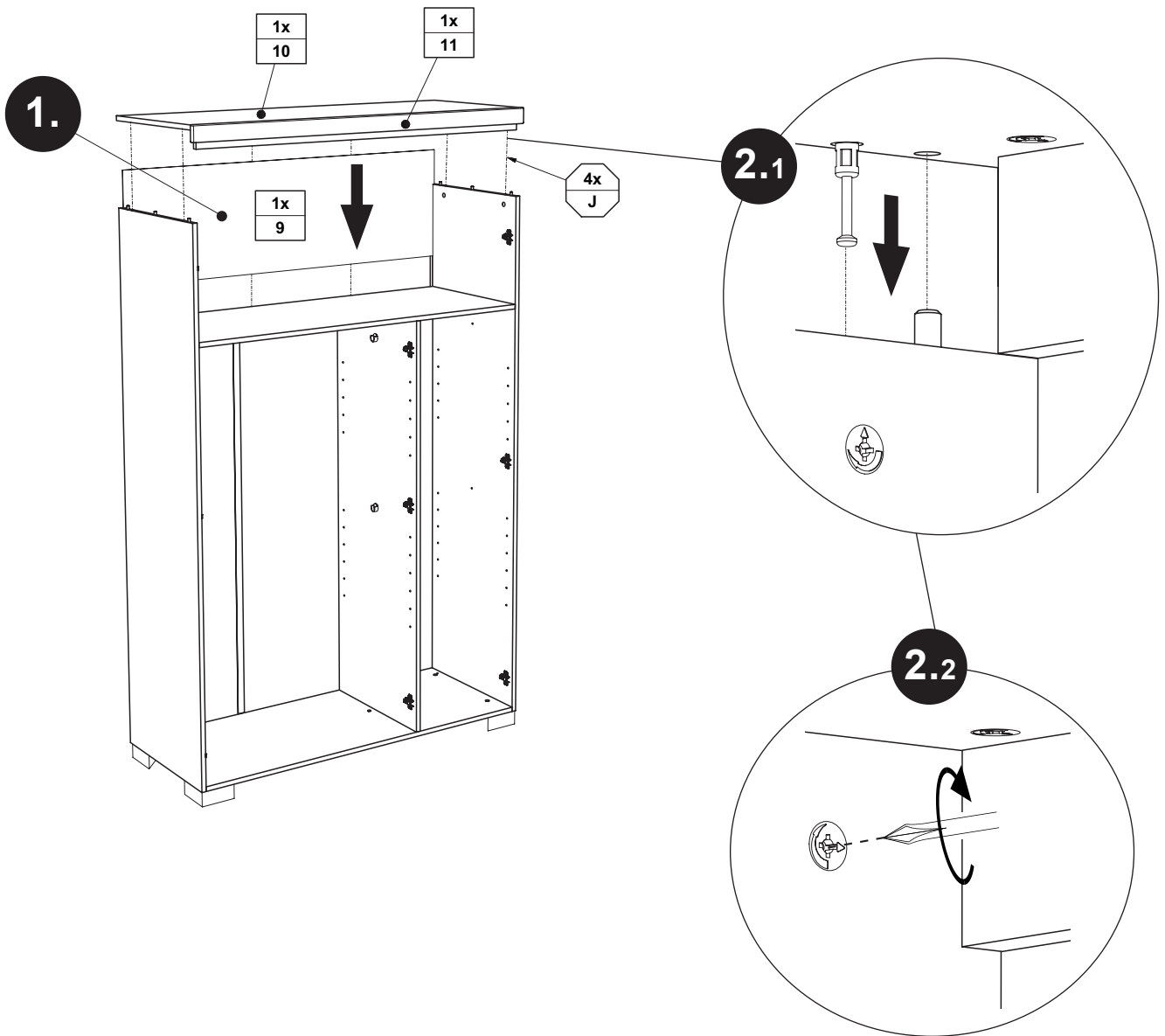

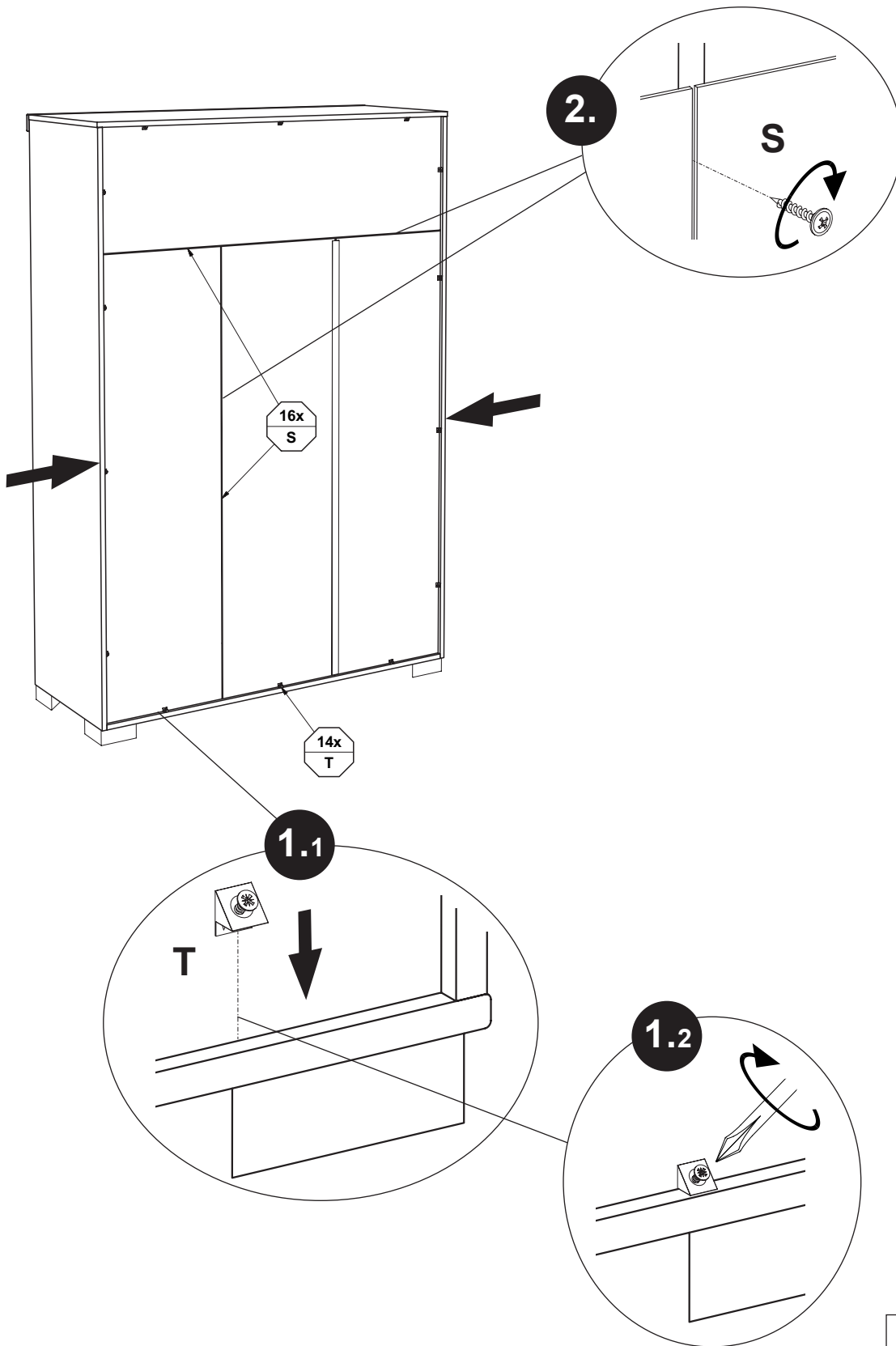

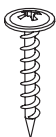

S	T
	
3,0 x 20 16x 681 4914	14x 681 2498

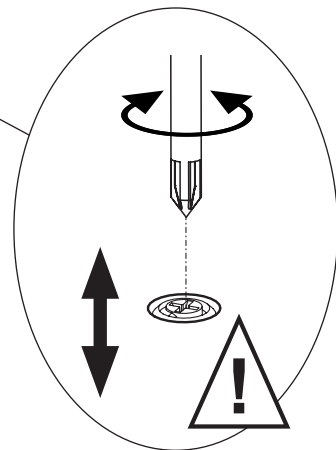
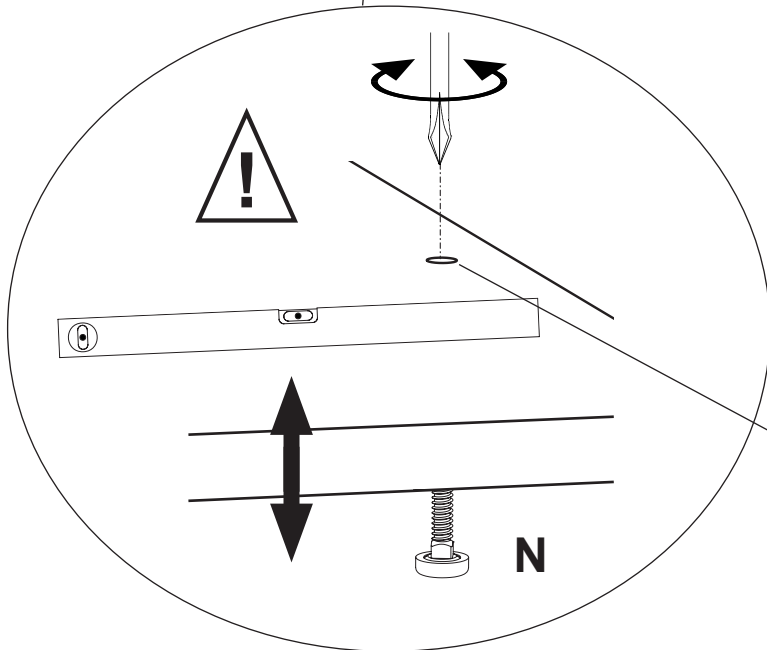
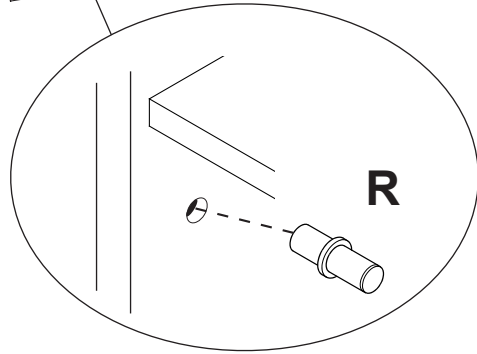
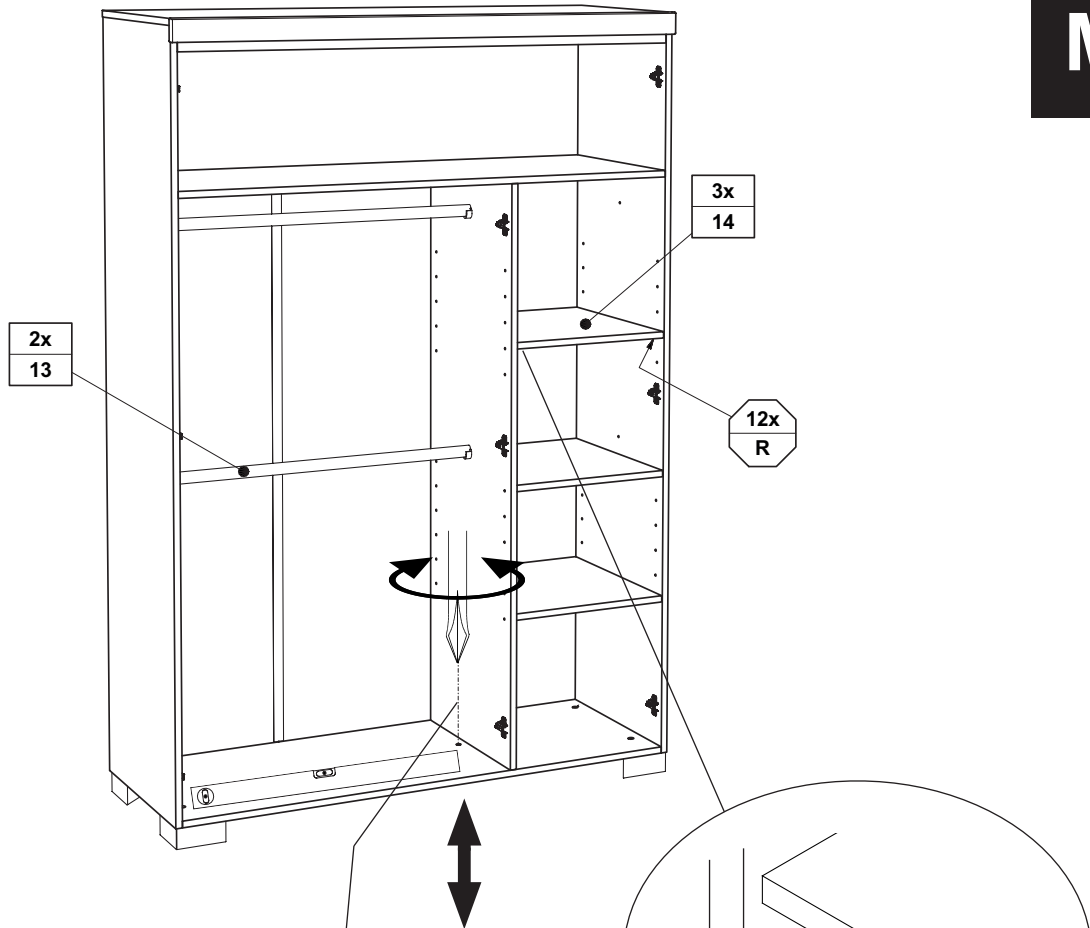

## Höhenverstellung !!

Height adjustment !  
 Réglage de la hauteur !  
 Hoogteverstelling !  
 Регулировка высоты !  
 高度調整!

R

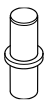

12x  
 681 0350

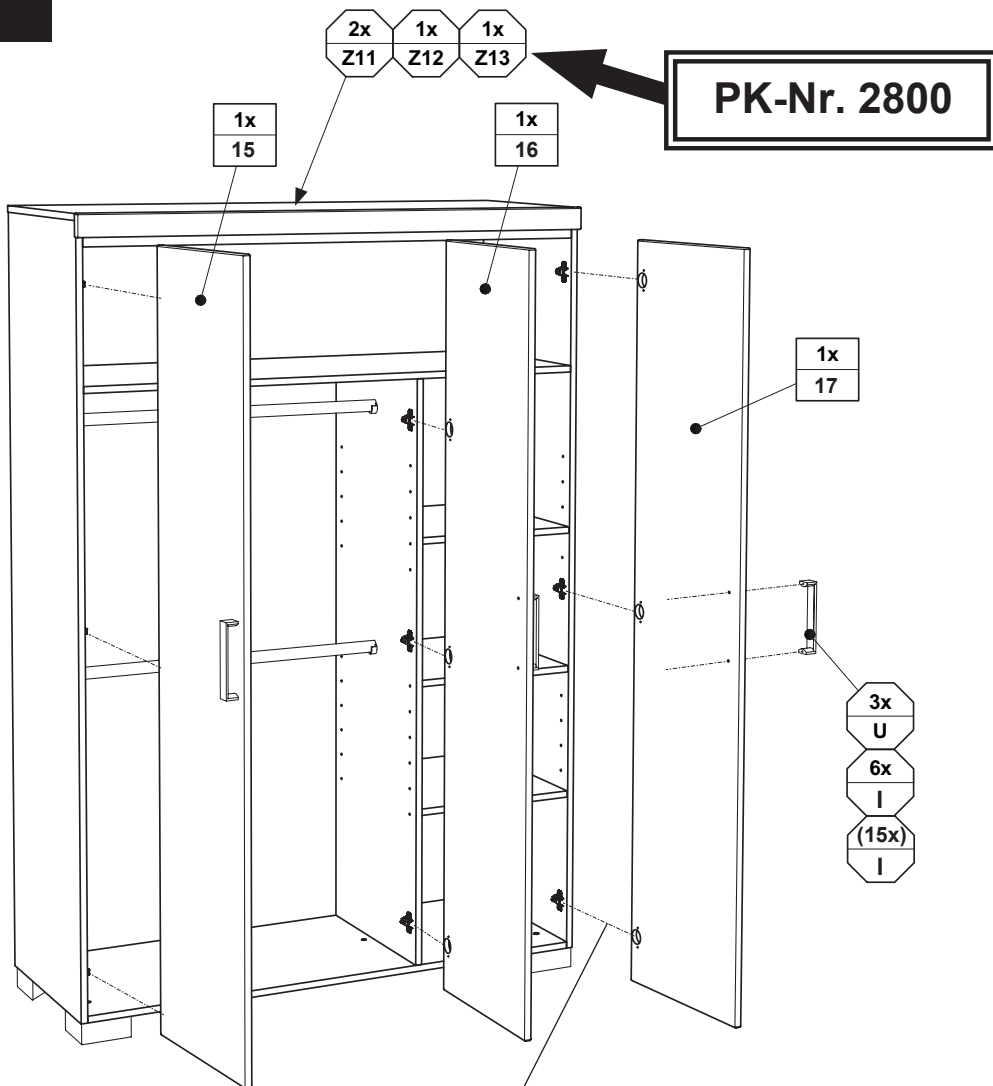

**U** Progr. HILJA + ALISA + KRISTIN 2

3x  
681 8051 SILBER

**U** Progr. LANA

3x  
681 8479 SCHIEFERGRAU

**U** Progr. LORIE

**Griffstange**  
Länge: 700mm

3x  
681 8442 SILBER

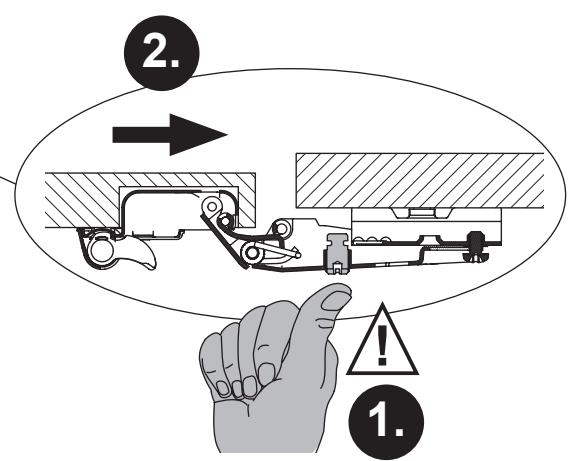
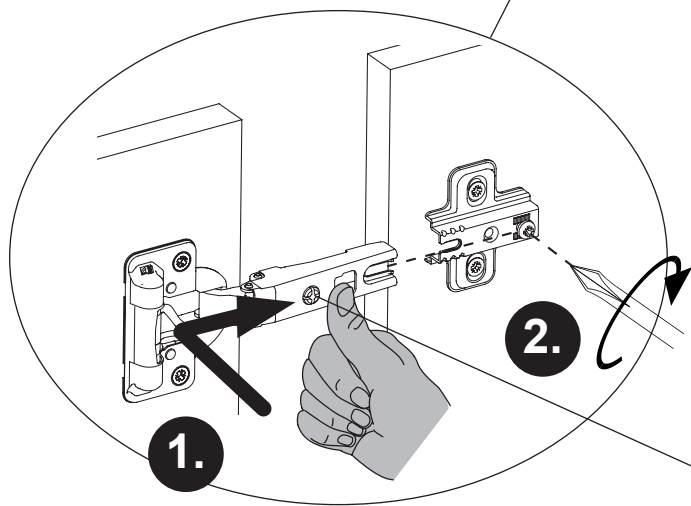

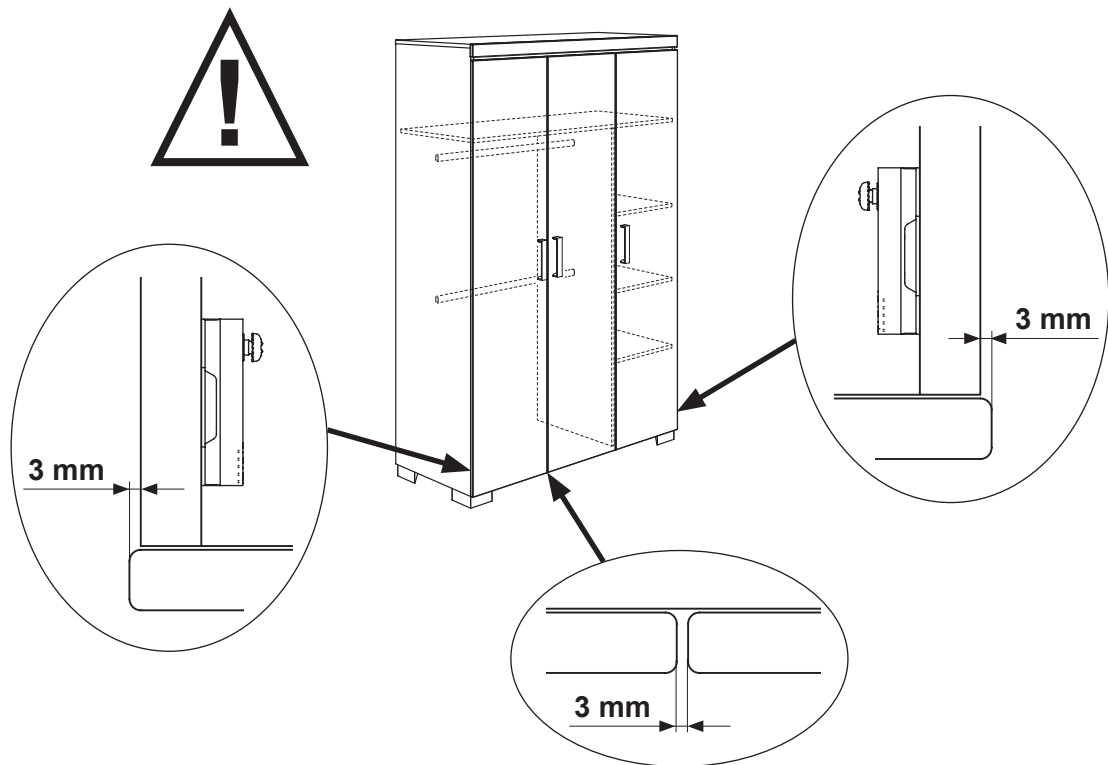

### Justierung der Türen

Adjustement of doors  
 Réglage des portes  
 Afstelling van de deuren  
 Регулировка дверок  
 门的调整

