

BAUANLEITUNG

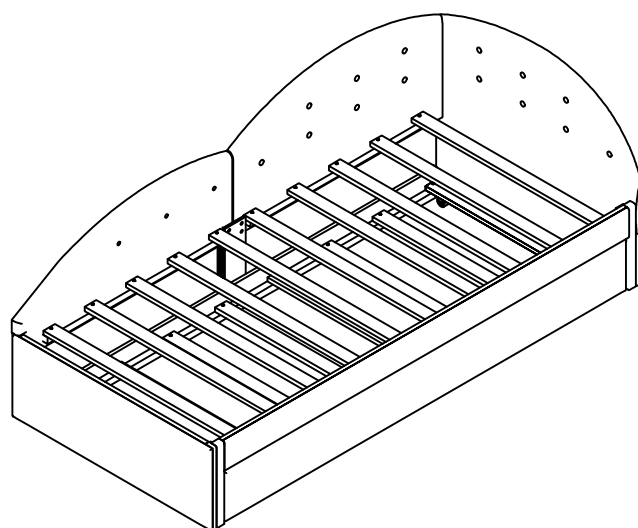

WF531687/88

Detail View

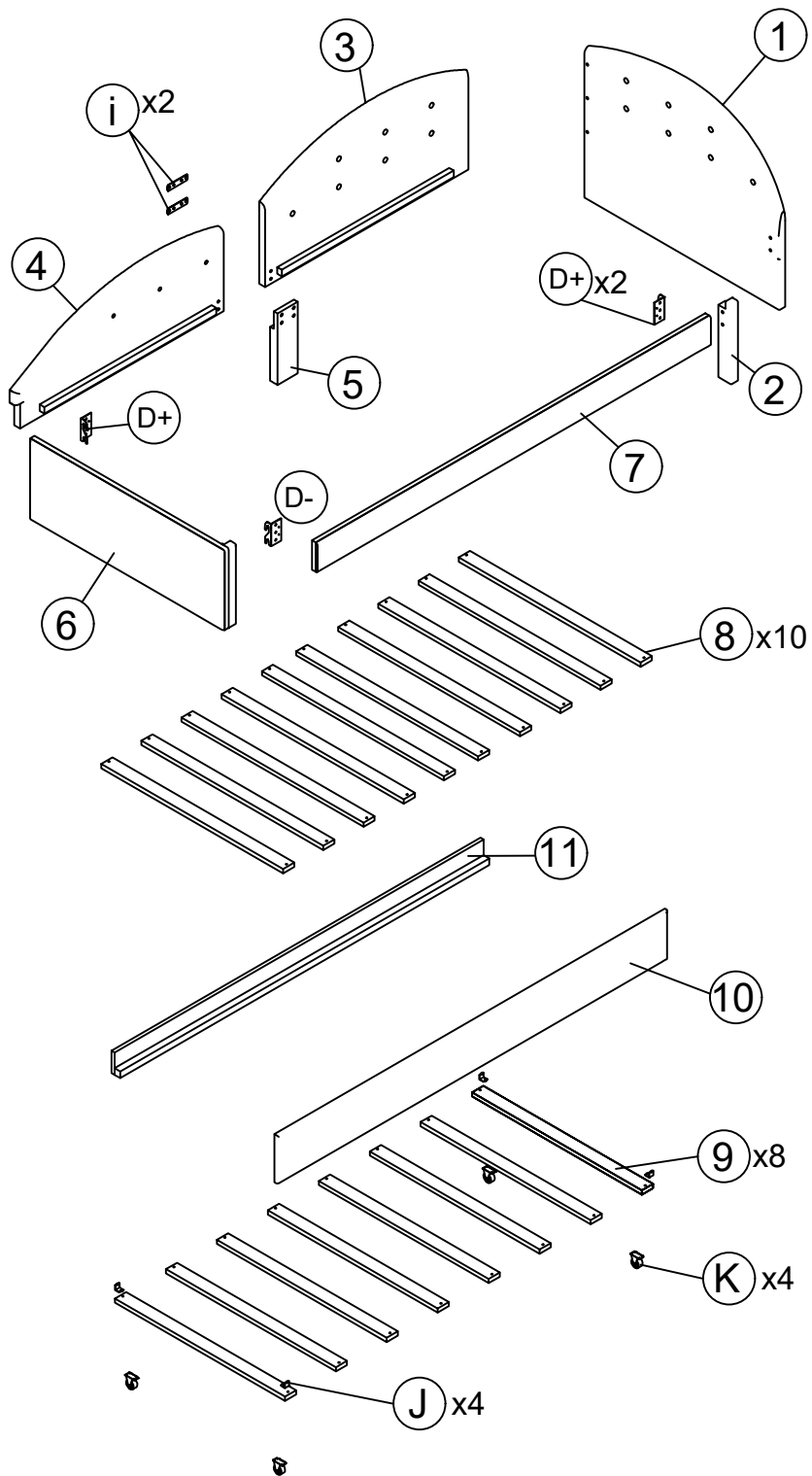

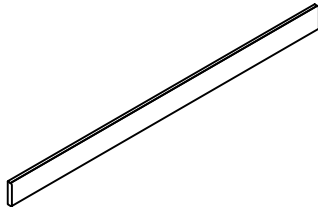
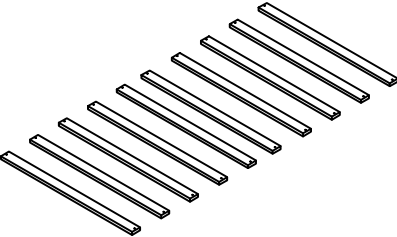
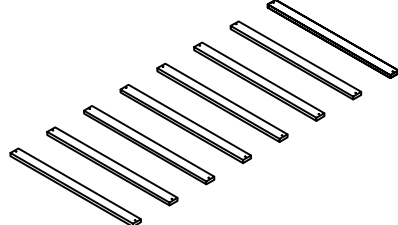
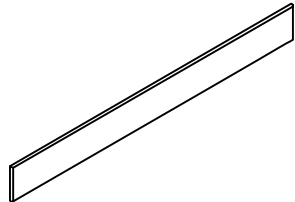
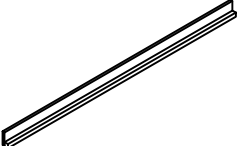

Liste der Einzelteile (Kasten 1)

WF531687





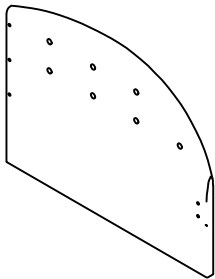
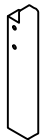
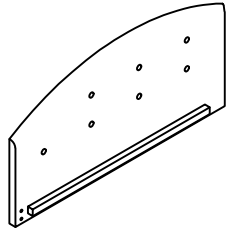
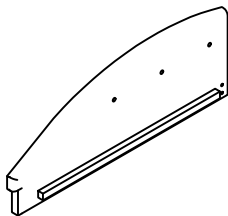

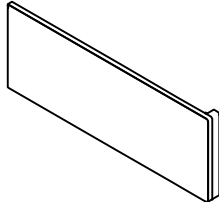

<p>7</p>  <p>Seitenschienen-1Stück</p>	<p>8</p>  <p>Lamellen-10Stück</p>	<p>9</p>  <p>Lamellen-8Stück</p>
<p>10</p>  <p>Untere Schiene -1Stück</p>	<p>11</p>  <p>Untere Schiene -1Stück</p>	

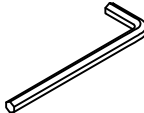
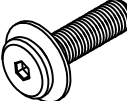
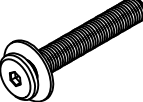
Liste der Einzelteile (Kasten 2)

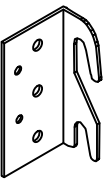
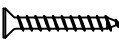
WF531688

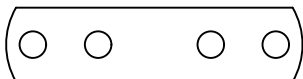

<p>1</p>  <p>Kopfteil-1Stück</p>	<p>2</p>  <p>Kopfteil-1Stück</p>	<p>3</p>  <p>Seitenschienen-1Stück</p>
<p>4</p>  <p>Seitenschienen-1Stück</p>	<p>5</p>  <p>Bettbeine(1Stück)</p>	<p>6</p>  <p>Fußbrett-1Stück</p>

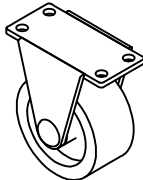
Hardwareliste (Kasten 2-WF531688)

<p>A</p>  <p>25*75mm</p>	<p>B</p>  <p>Ø8*30mm</p>	<p>C</p>  <p>Ø8*50mm</p>
<p>Inbusschlüssel(1Stück)</p>	<p>Schrauben(7Stück)</p>	<p>Schrauben(9Stück)</p>
<p>D+</p>  <p>50*30*2mm</p>	<p>D-</p>  <p>50*30*2mm</p>	<p>E</p>  <p>40mm</p>
<p>Anschluss(2Stück)</p>	<p>Anschluss(1Stück)</p>	<p>Schrauben(36Stück)</p>
<p>F</p>  <p>20mm</p>	<p>G</p>  <p>Ø8*15mm</p>	<p>H</p>  <p>Ø8*20mm</p>
<p>Schrauben(24Stück)</p>	<p>Schrauben(8Stück)</p>	<p>Schrauben(8Stück)</p>
<p>i</p>  <p>100*25*2mm</p>	<p>J</p> 	<p>K</p> 
<p>Anschluss(2Stück)</p>	<p>Anschluss(4Stück)</p>	<p>Anschluss(4Stück)</p>



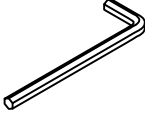

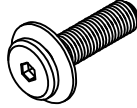
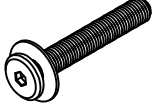
Hinweis: Wir empfehlen Ihnen, Ihr Bett im ebenen Boden aufzubauen.

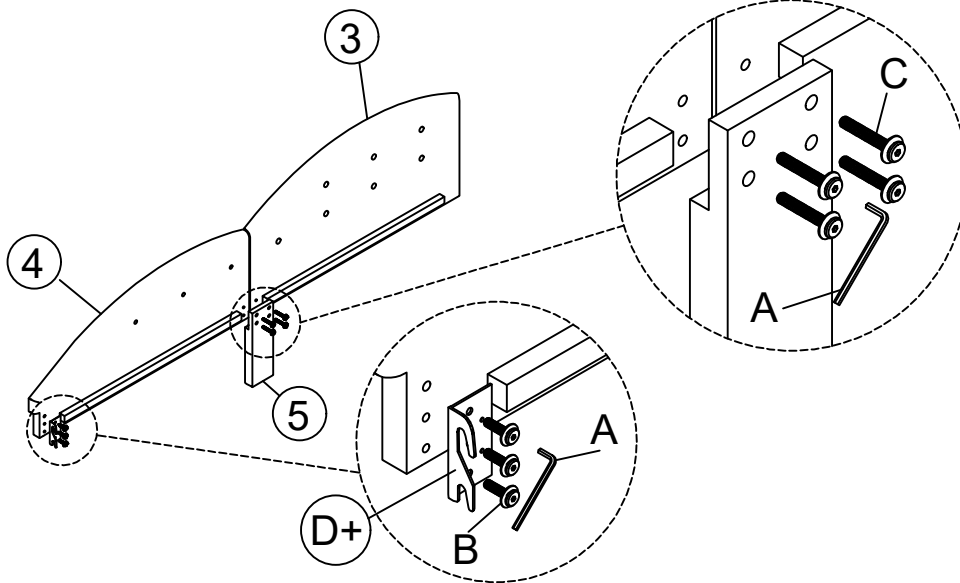
Schritt 1

A	D+	B	C
		 Ø8*30mm	 Ø8*50mm
	1Stück	3Stück	4Stück

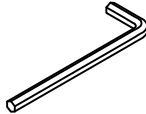

Schritt 2

A	H	D+	D-
	 Ø8*20mm		
	8Stück	1Stück	1Stück

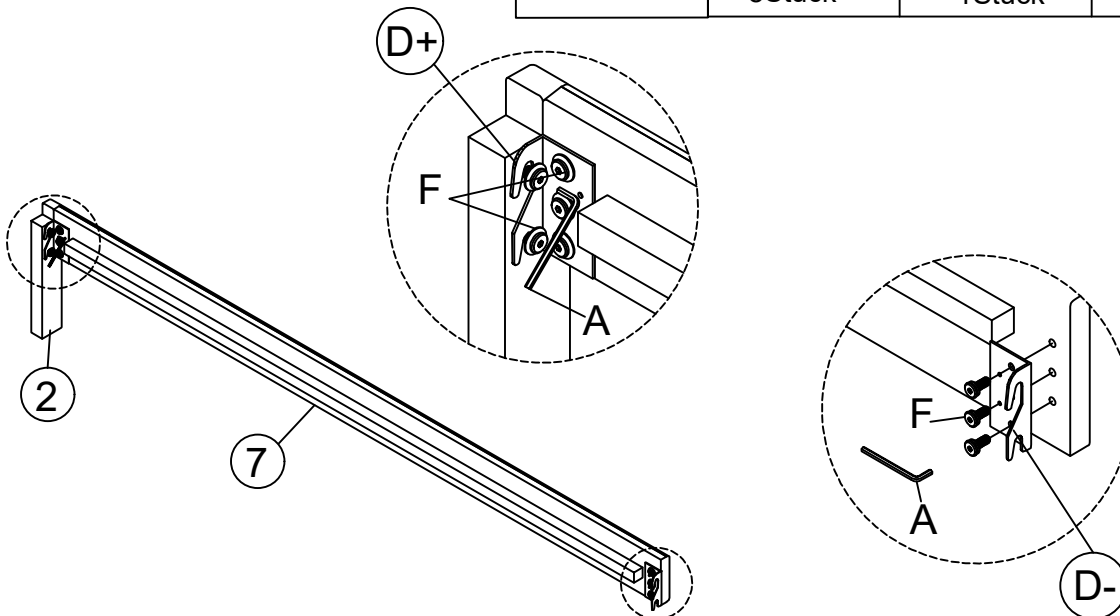

Schritt 3

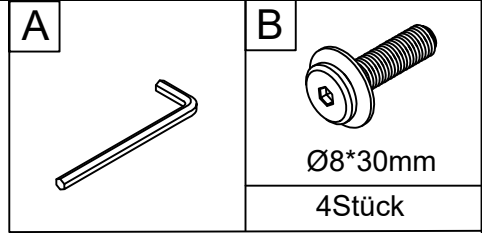
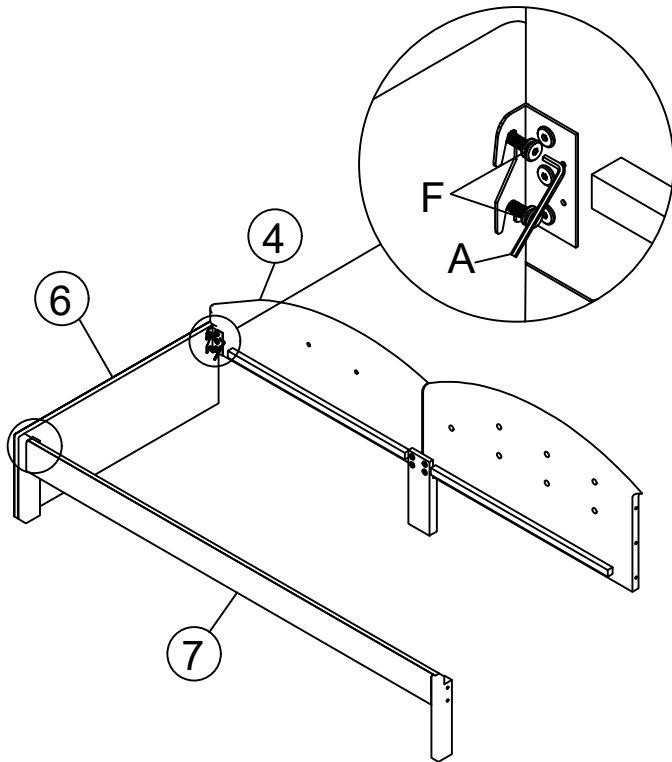

Schritt 4

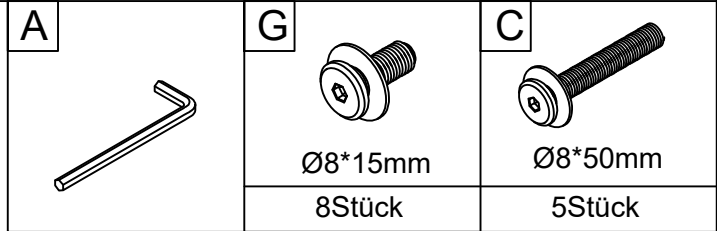
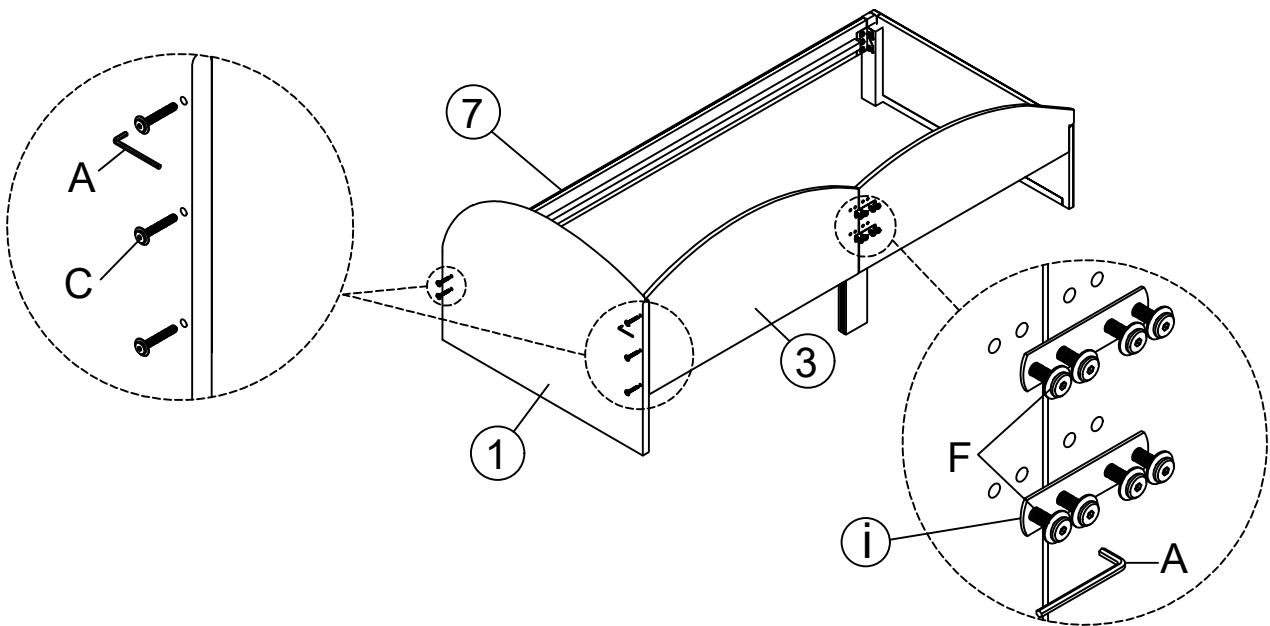

Schritt 5

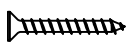
E

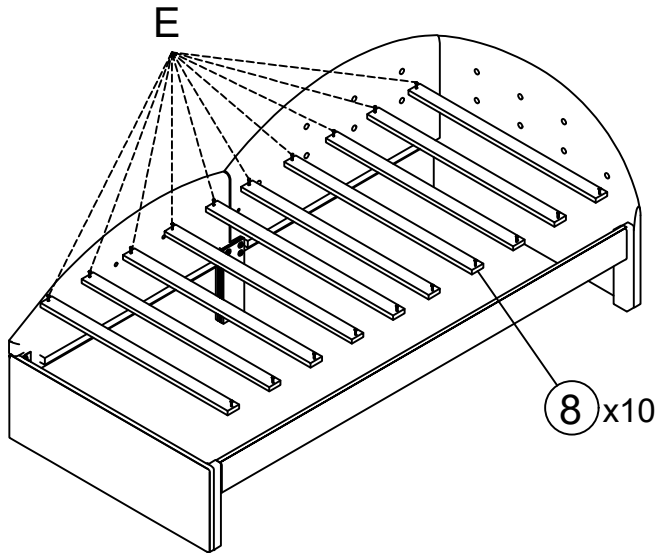
40mm
20Stück

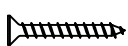

Schritt 6

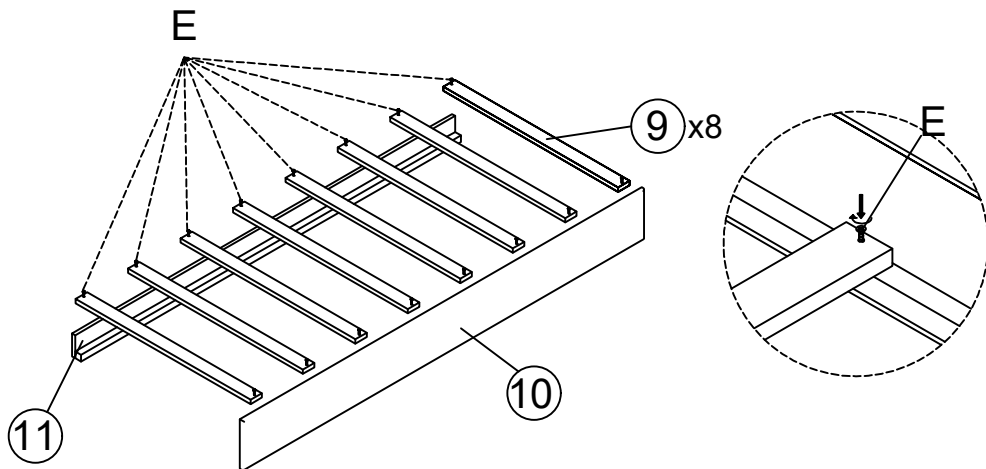
E

40mm
16Stück

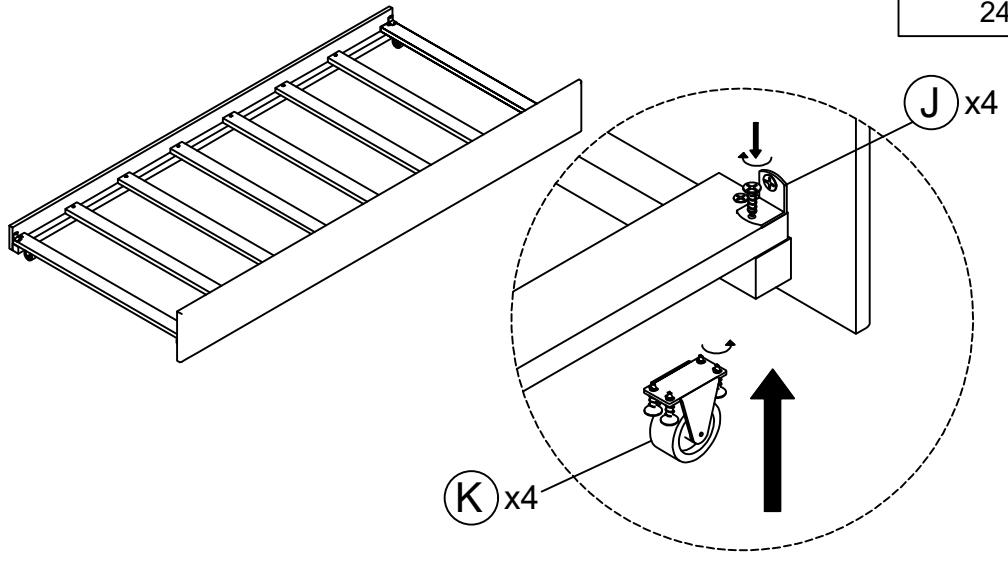

Schritt 7

F
 20mm
24Stück



Schritt 8

