

# ASSEMBLY INSTRUCTION

## PATIO SECTIONAL SOFA SETS

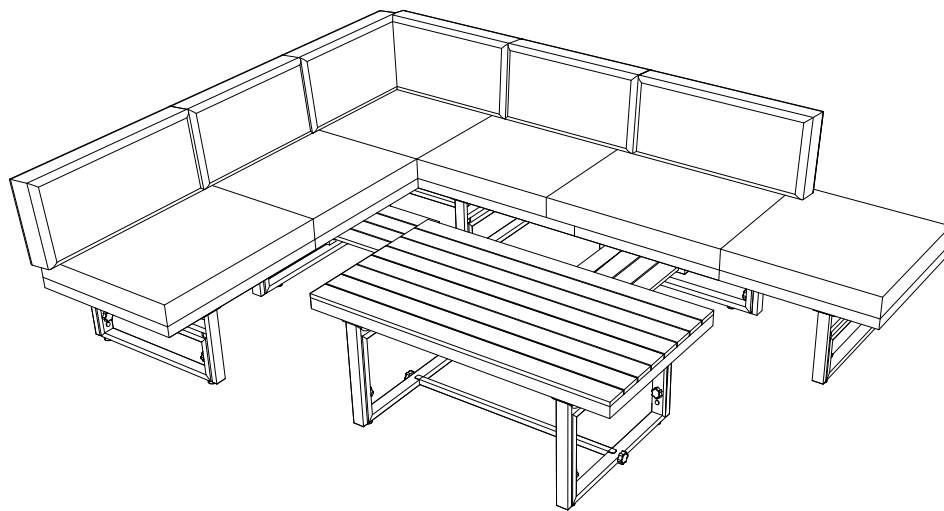

**WF318264; WF318265**  
**WF318266; WF318267**

Before installation, insert the screws into the holes and tighten them, but do not tighten them to 100%, 70% to 80% is sufficient. Finally, after all screws are installed, tighten all screws to 100%. If you encounter these issues, such as if the holes cannot be aligned or some parts cannot be installed, please check if the screws are used correctly and adjust the tightness of the screws.

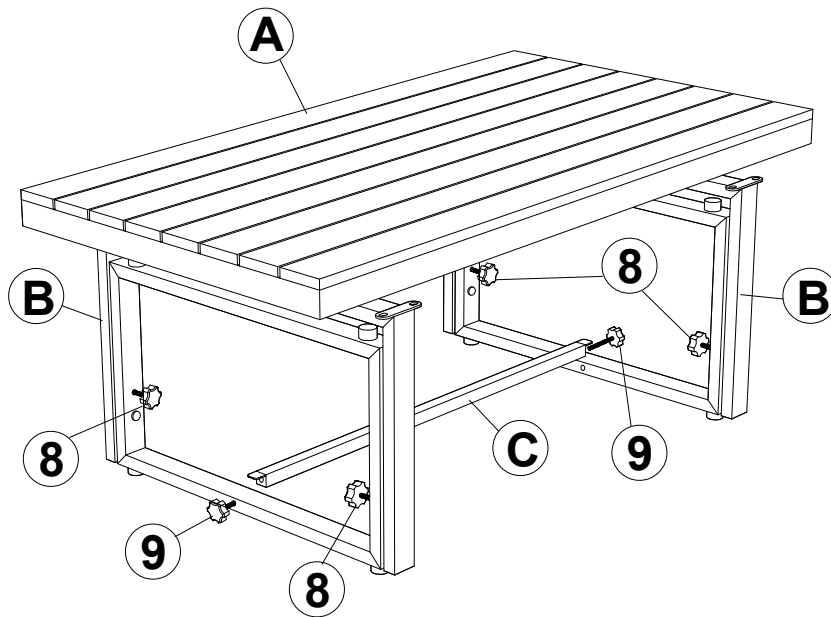

**x1**

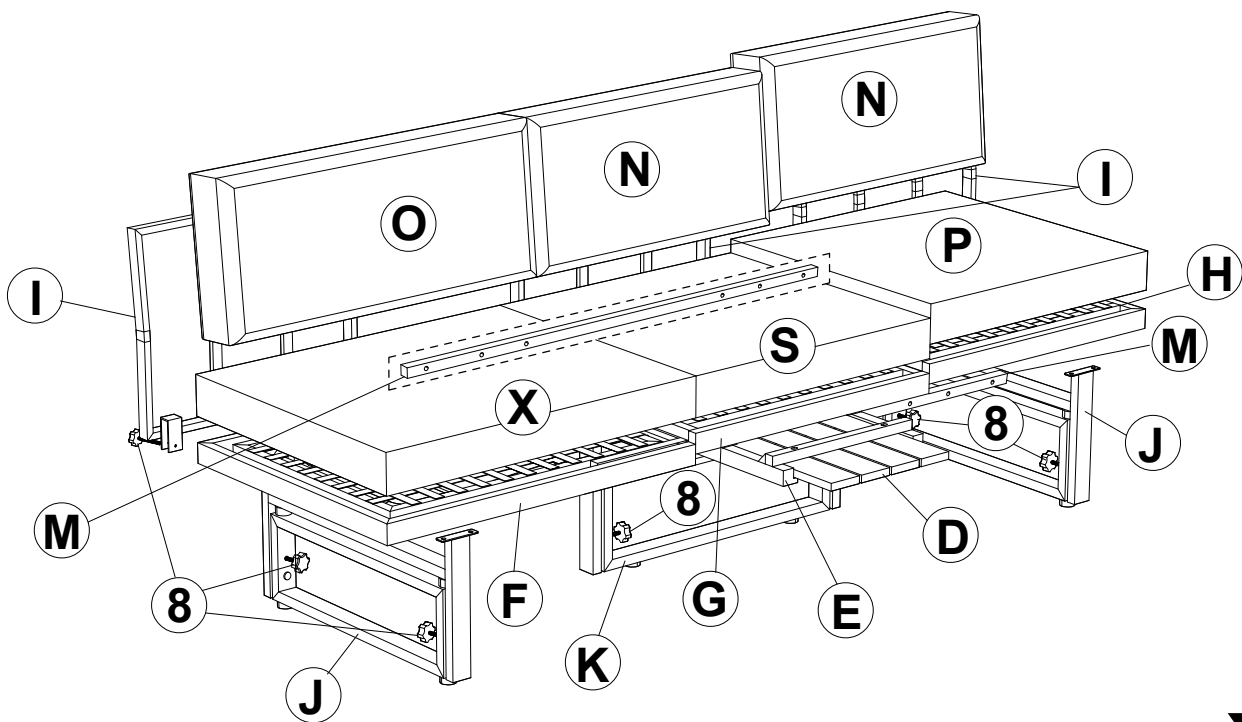

**x2**

**Notice:**

2. 50% Tighten before fixing all screws, Allen wrench is recommended instead of an electric drill.
3. Place the item on a flat ground to adjust and make sure it remains stable.
4. Tighten up all screws with tools gradually.
5. If the screws are not aligned with holes during assembly, please loosen all the other screws to 50% and continue the assembly process.
6. If the item is not stable, please loosen all the screws, adjust it on a flat ground and tighten up all screws again.
7. Note : If one or some screws are fully tightened during assembly, chances are the others will not be aligned with holes. In addition, all the holes are designed to be relatively larger to provide more space for the adjustment of the screws.

# Part List

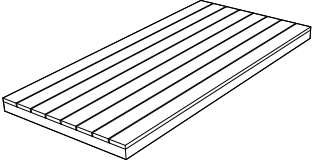
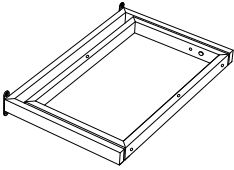
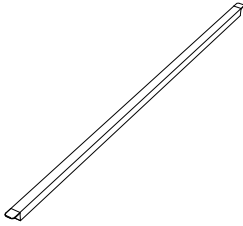
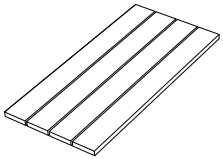
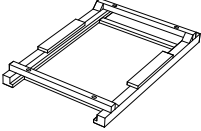
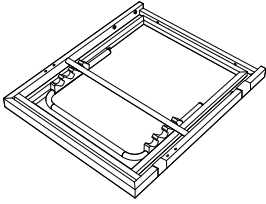
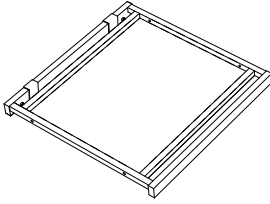
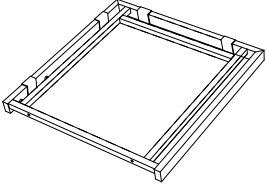
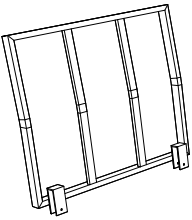
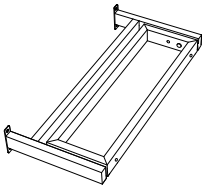
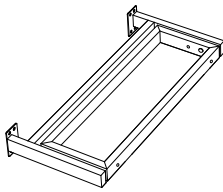
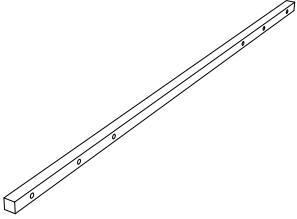
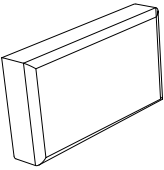
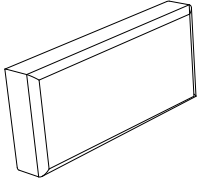
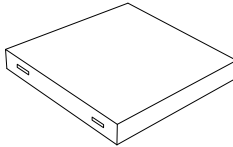
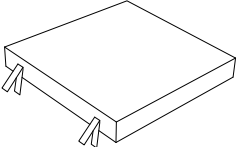
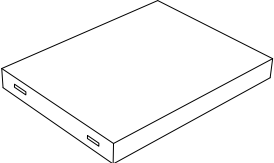
<p><b>A</b></p>  <p><b>Top Table (1 pc)</b></p>	<p><b>B</b></p>  <p><b>Leg Table (2 pcs)</b></p>	<p><b>C</b></p>  <p><b>Supporting Bar (1 pc)</b></p>	<p><b>D</b></p>  <p><b>Side table (2 pcs)</b></p>
<p><b>E</b></p>  <p><b>Wooden Tray (2 pcs)</b></p>	<p><b>F</b></p>  <p><b>Seat Bench 1 (2 pcs)</b></p>	<p><b>G</b></p>  <p><b>Seat Bench 2 (2 pcs)</b></p>	<p><b>H</b></p>  <p><b>Seat Bench 3 (2 pcs)</b></p>
<p><b>I</b></p>  <p><b>Back Bench (6 pcs)</b></p>	<p><b>J</b></p>  <p><b>Leg Bench (4 pcs)</b></p>	<p><b>K</b></p>  <p><b>Supporting Leg (2 pcs)</b></p>	<p><b>M</b></p>  <p><b>Connecting Bar (4 pcs)</b></p>
<p><b>N</b></p>  <p><b>Back Cushion 1 (4 pcs)</b></p>	<p><b>O</b></p>  <p><b>Back Cushion 2 (2 pcs)</b></p>	<p><b>P</b></p>  <p><b>Seat Cushion 1 (2 pcs)</b></p>	<p><b>S</b></p>  <p><b>Seat Cushion 2 (2 pcs)</b></p>
<p><b>X</b></p>  <p><b>Seat Cushion 3 (2 pcs)</b></p>			

# Hardware List

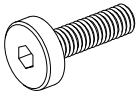
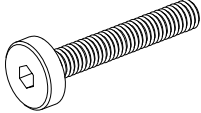
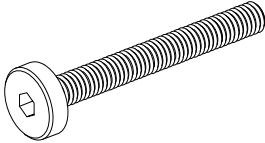
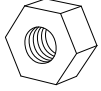
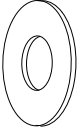
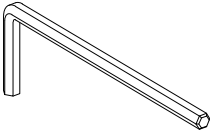
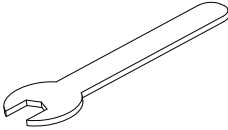
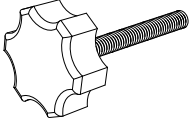
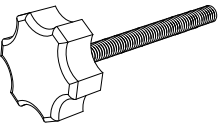
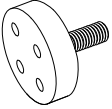
<p><b>1</b></p>  <p><b>Extra (3 pcs) Bolt M6x15 (40 pcs)</b></p>	<p><b>2</b></p>  <p><b>Extra (3 pcs) Bolt M6x35 (32 pcs)</b></p>	<p><b>3</b></p>  <p><b>Extra (1 pc) Bolt M6x55 (8 pcs)</b></p>	<p><b>4</b></p>  <p><b>Extra (1 pc) Eru M6 (8pcs)</b></p>
<p><b>5</b></p>  <p><b>Extra (3 pcs) Flat Washer M6 (88 pcs)</b></p>	<p><b>6</b></p>  <p><b>Allen Key (2 pcs)</b></p>	<p><b>7</b></p>  <p><b>Key (1 pc)</b></p>	<p><b>8</b></p>  <p><b>Extra (2 pcs) Fixed Bolt 1 (28 pcs)</b></p>
<p><b>9</b></p>  <p><b>Fixed Bolt 2 (2 pcs)</b></p>	<p><b>10</b></p>  <p><b>Extra (2 pcs) Adjustable Level Leg(32 pcs)</b></p>		



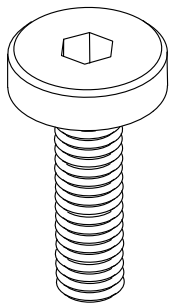

**BOLT**  
**M6x15 MM**

1

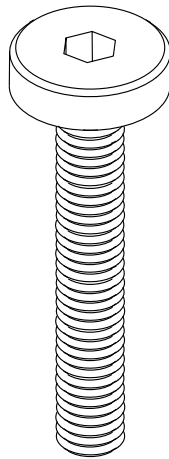

**BOLT**  
**M6x35 MM**

2

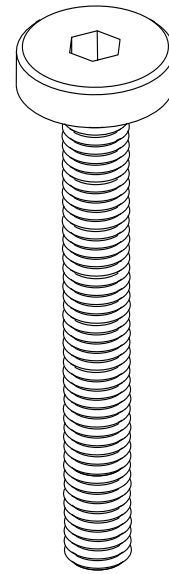

**BOLT**  
**M6x55 MM**

3

Please note that the shapes of bolts 1 and 2 and 3 are similar.  
Please install according to the instructions and distinguish them!

# CARTON CONTENT:

## WF318264

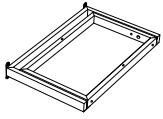

**B** x2

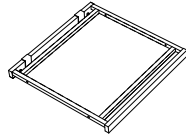

**G** x1

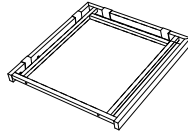

**H** x1

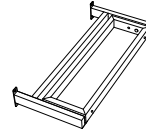

**J** x1

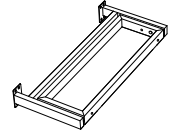

**K** x1

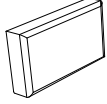

**N** x2

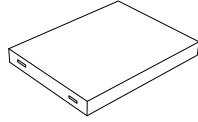

**X** x2

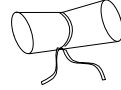

Hardware

## WF318265

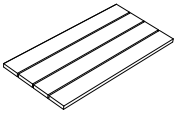

**D** x2

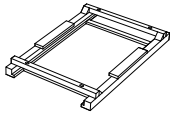

**E** x2

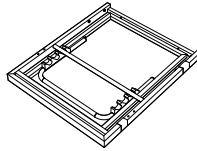

**F** x2

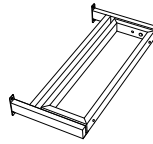

**J** x2

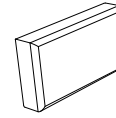

**N** x1

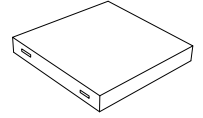

**P** x2

## WF318266

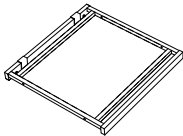

**G** x1

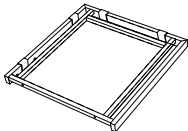

**H** x1

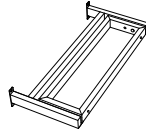

**J** x1

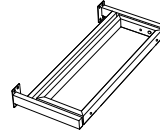

**K** x1

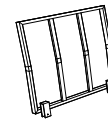

**I** x6

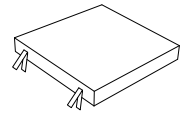

**S** x2

## WF318267

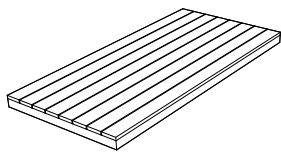

**A** x1

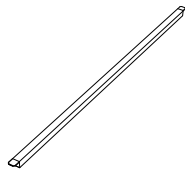

**C** x1

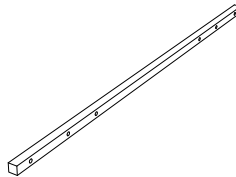

**M** x4

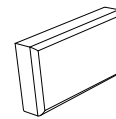

**N** x1

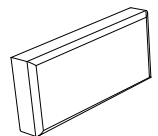

**O** x2

# STEP 1

**B** x1

**10** x4

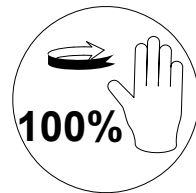
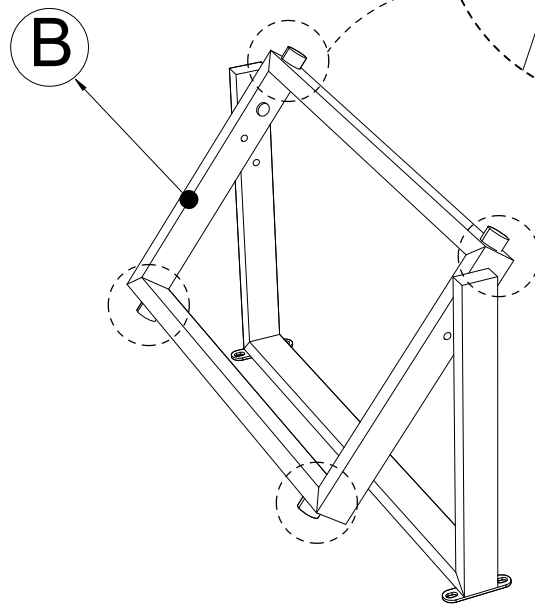

**x2**

Attach Adjustable Level Leg (10) & Leg Table (B), tighten The details with hand

# STEP 2

**A** x1

**1** x8

**5** x8

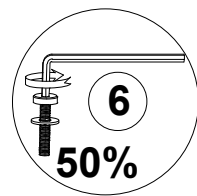
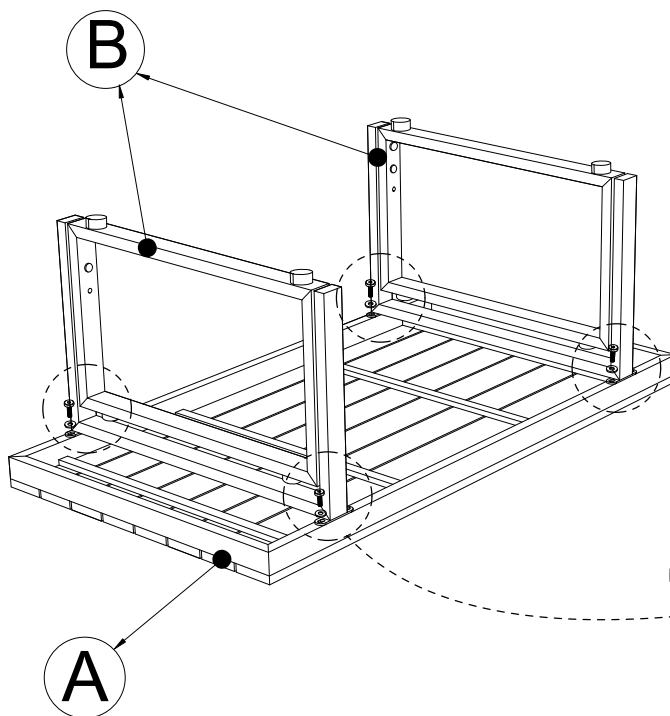

Connect the part from step 1 & the Top table, tighten Bolt (1) & Flat Washer (5) with Allen Key (6).

# STEP 3

Ⓒ x1

⑨ x2

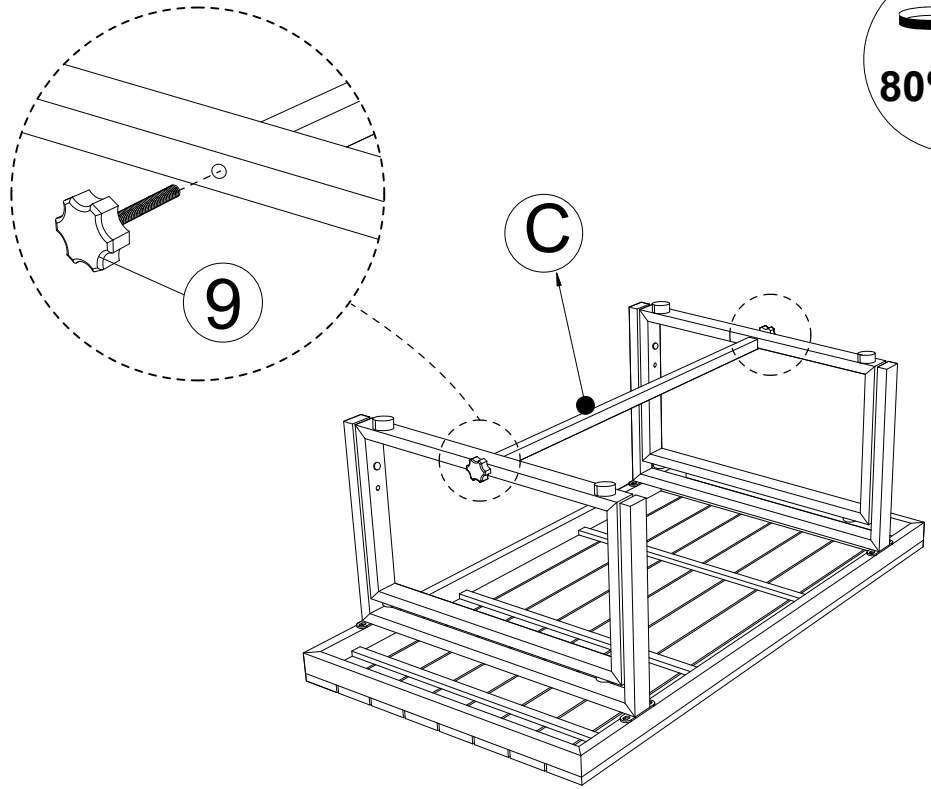

80%

Connect the part from step 2 & Supporting Bar (C)  
Tighten Fixed Bolt (9) with hand

# STEP 4

⑧ x4

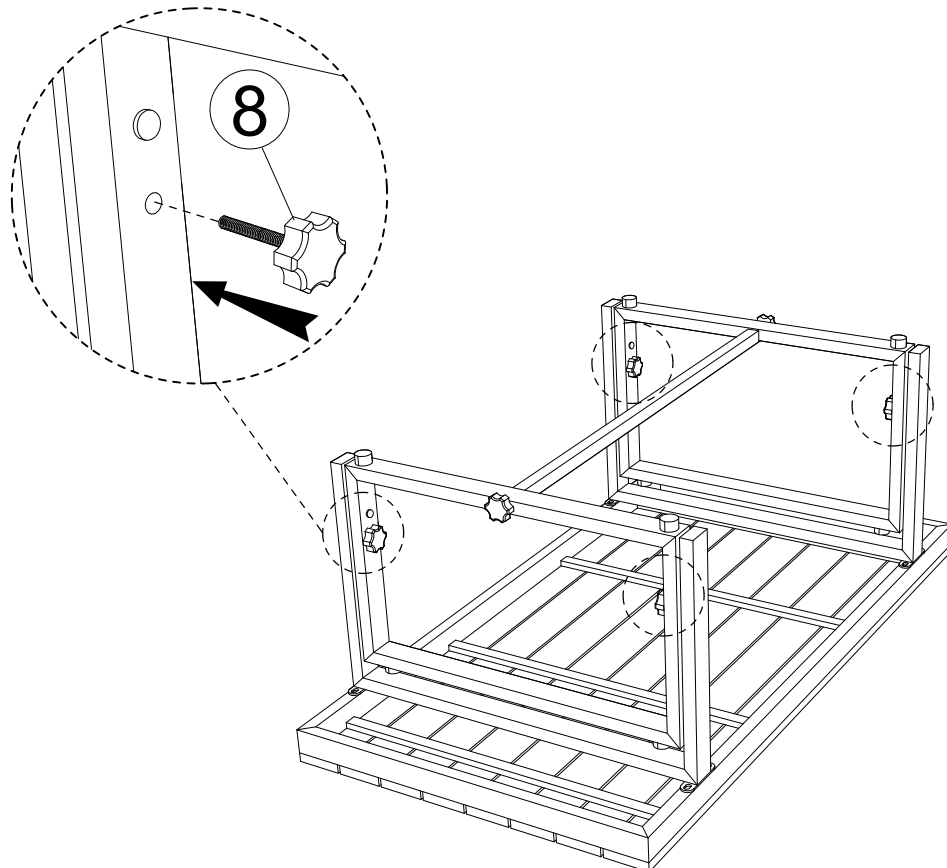

80%

Hold The original sharp of Leg (B), tighten Fixed Bolt (8) with hand

# STEP 5

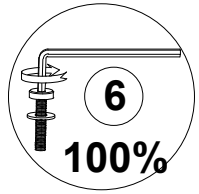
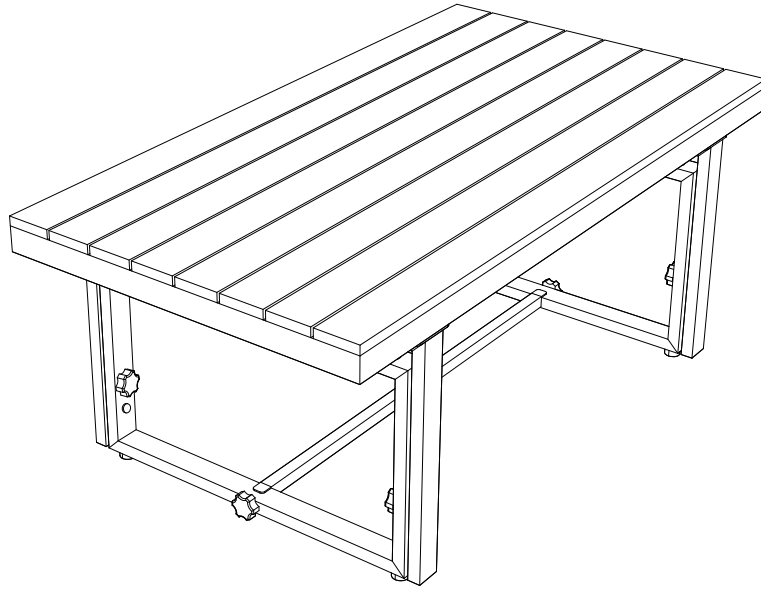

**Put the Table upright, firmly tighten Bolts with Allen Key (5) & Hand**

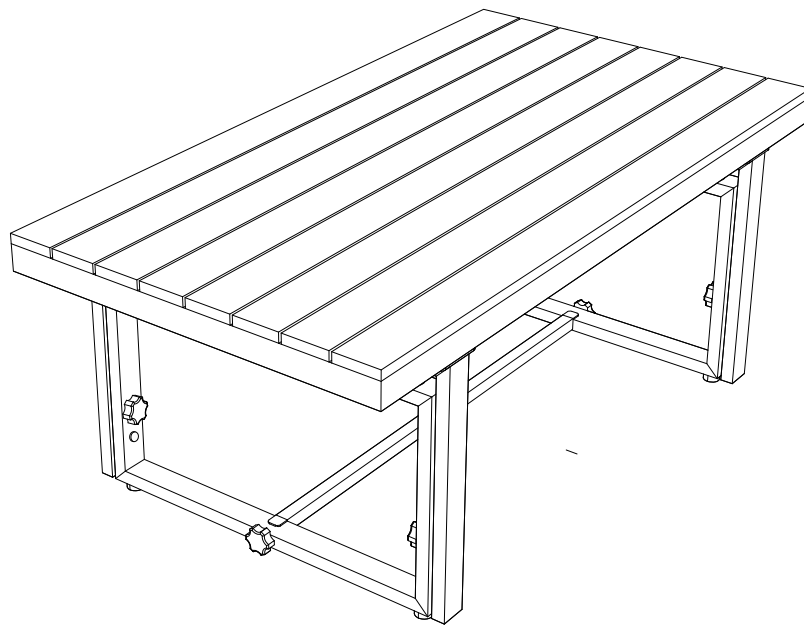

**Finish the table**

## STEP 6A

Modify the height  
of Leg Table

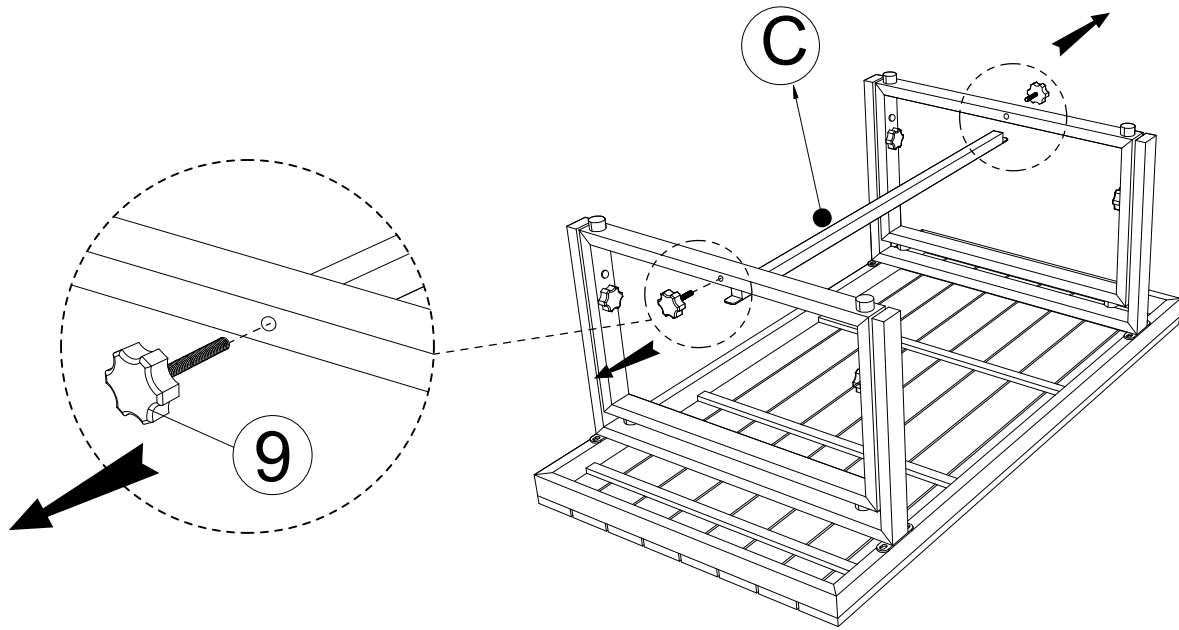
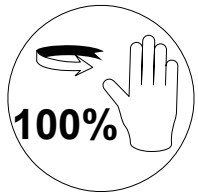

Turn upside down the Table from step 5 & remove Supporting Bar (C)  
Loosen & remove Fixed Bolt (9)

## STEP 6B

Modify the height  
of Leg Table

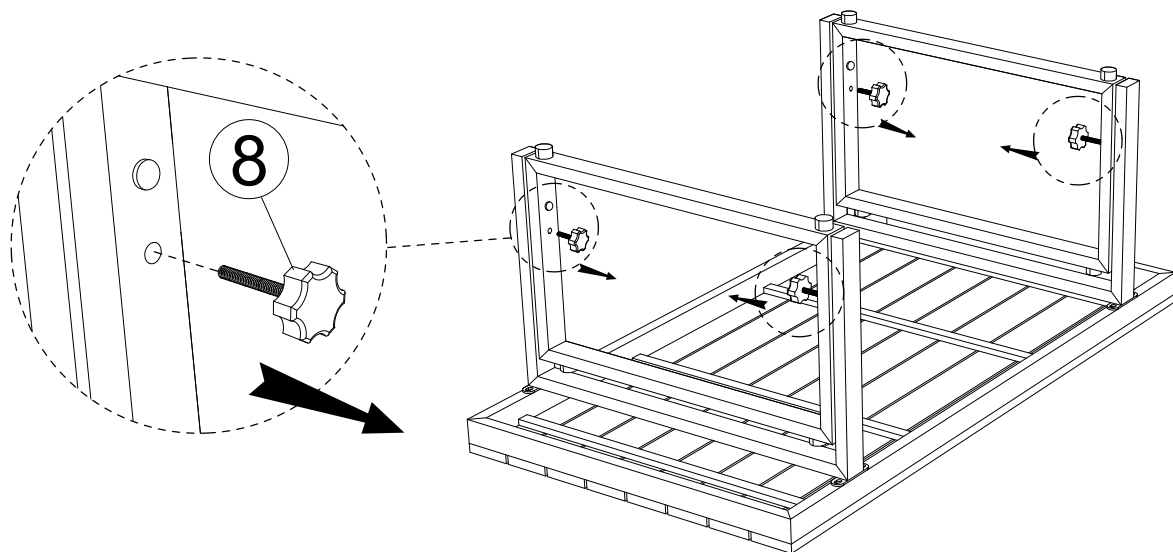
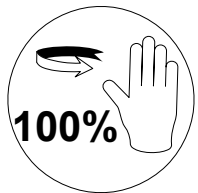

Loosen & remove Fixed Bolt (8)

# STEP 6C

Modify the height  
of Leg Table

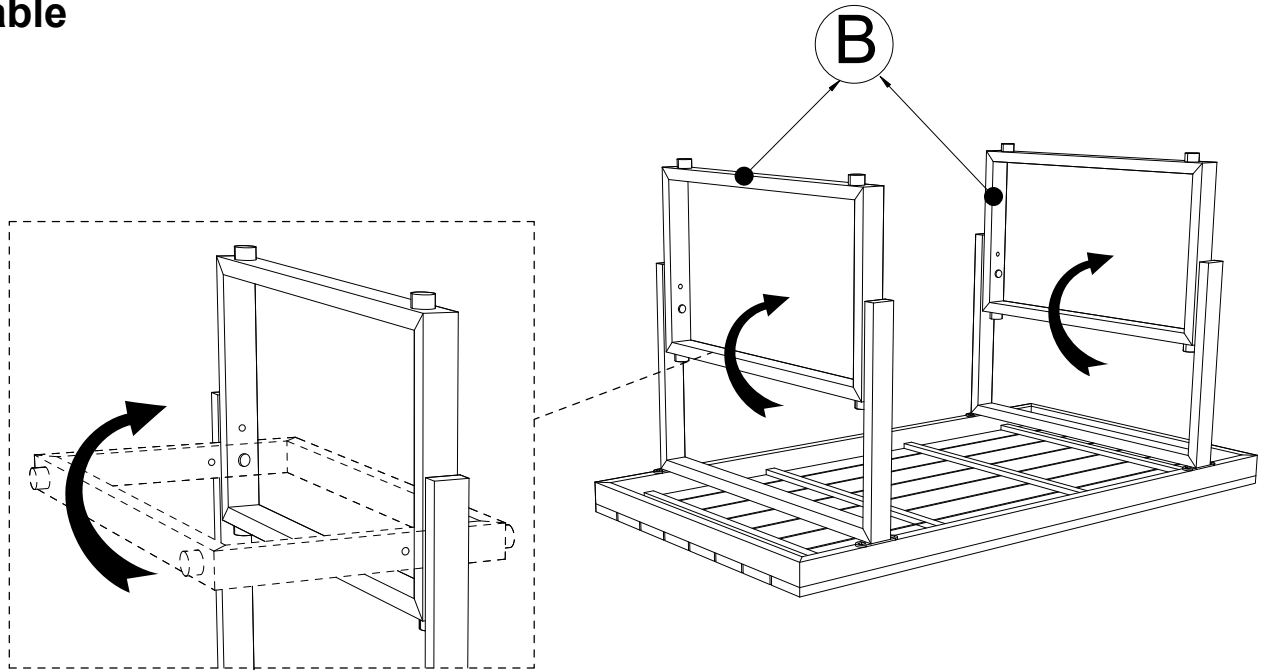

Rotate the inner part of (B) out with the angle 180°

# STEP 6D

Modify the height  
of Leg Table

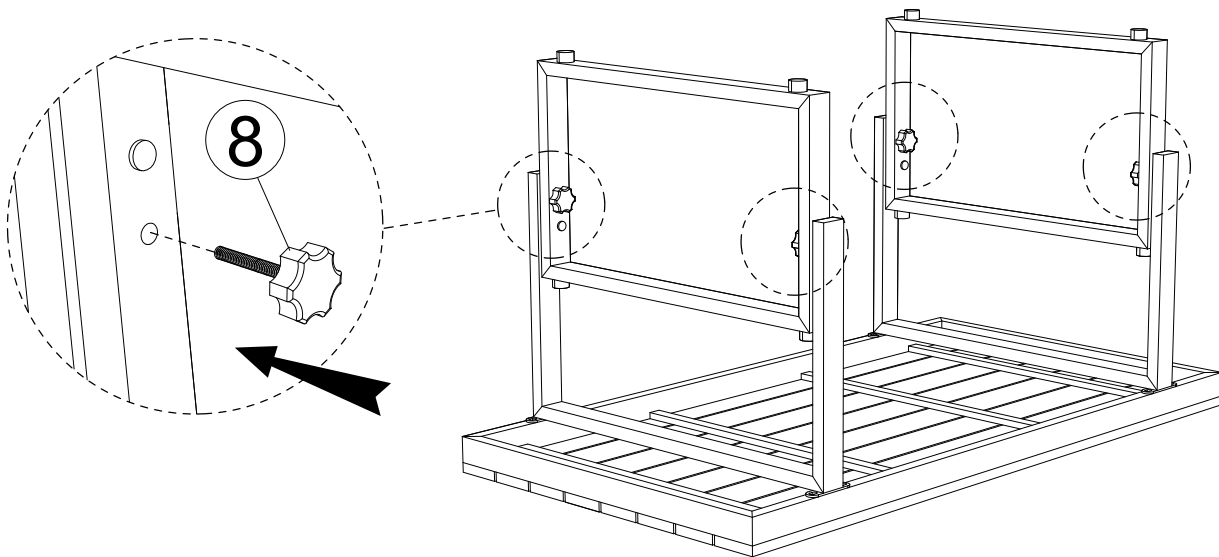
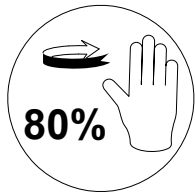

Tighten Fixed Bolt (8) with hand



## STEP 6E

Modify the height  
of Leg Table

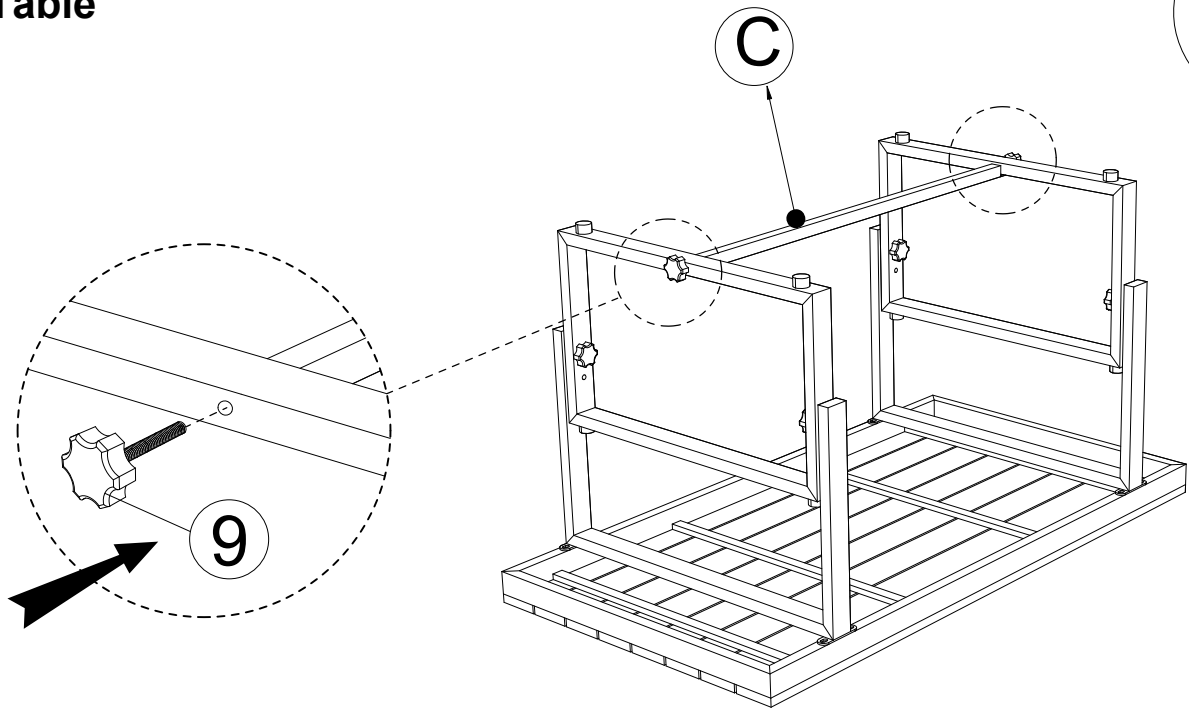

Connect again the Supporting Bar (C). Tighten Fixed Bolt (9) with hand

## STEP 6F

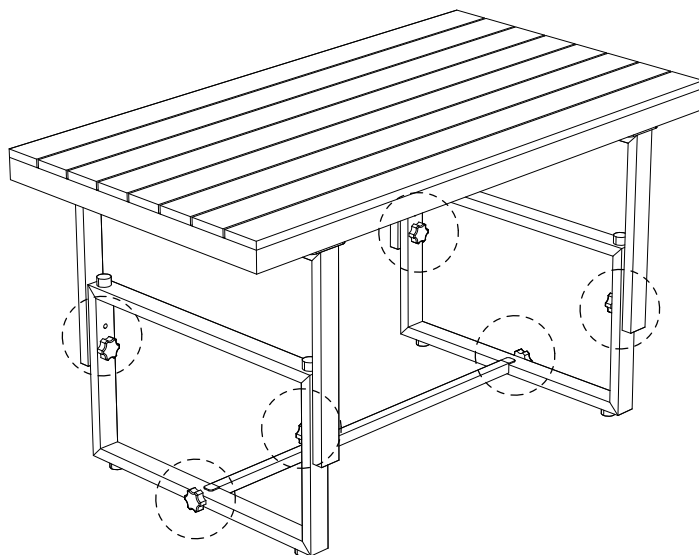

Firmly, Tighten all Fixed Bolt with hand.

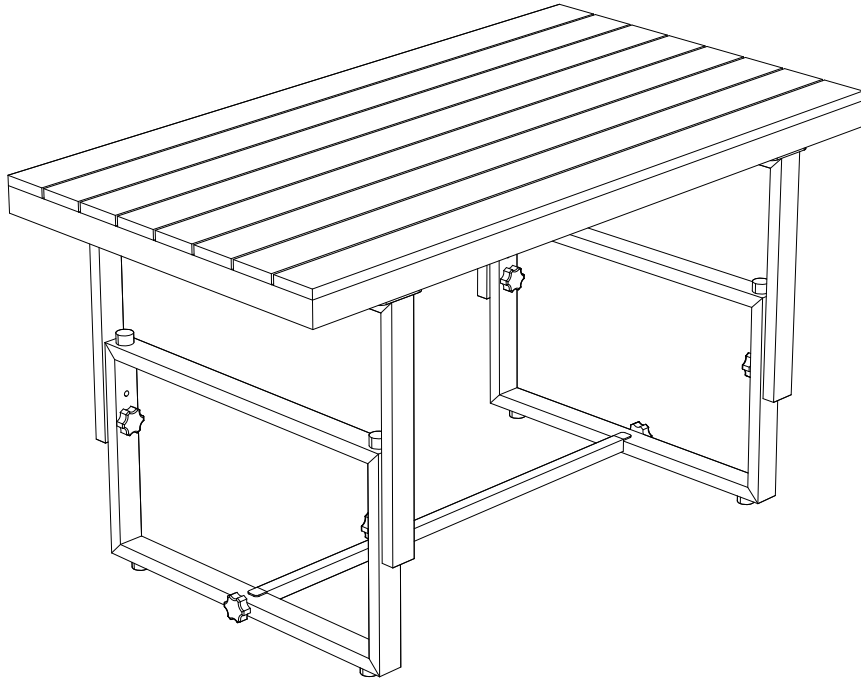

**Finish the heigher table**

# STEP 7

ⓐ x1

ⓑ x1

ⓒ x2

ⓓ x2

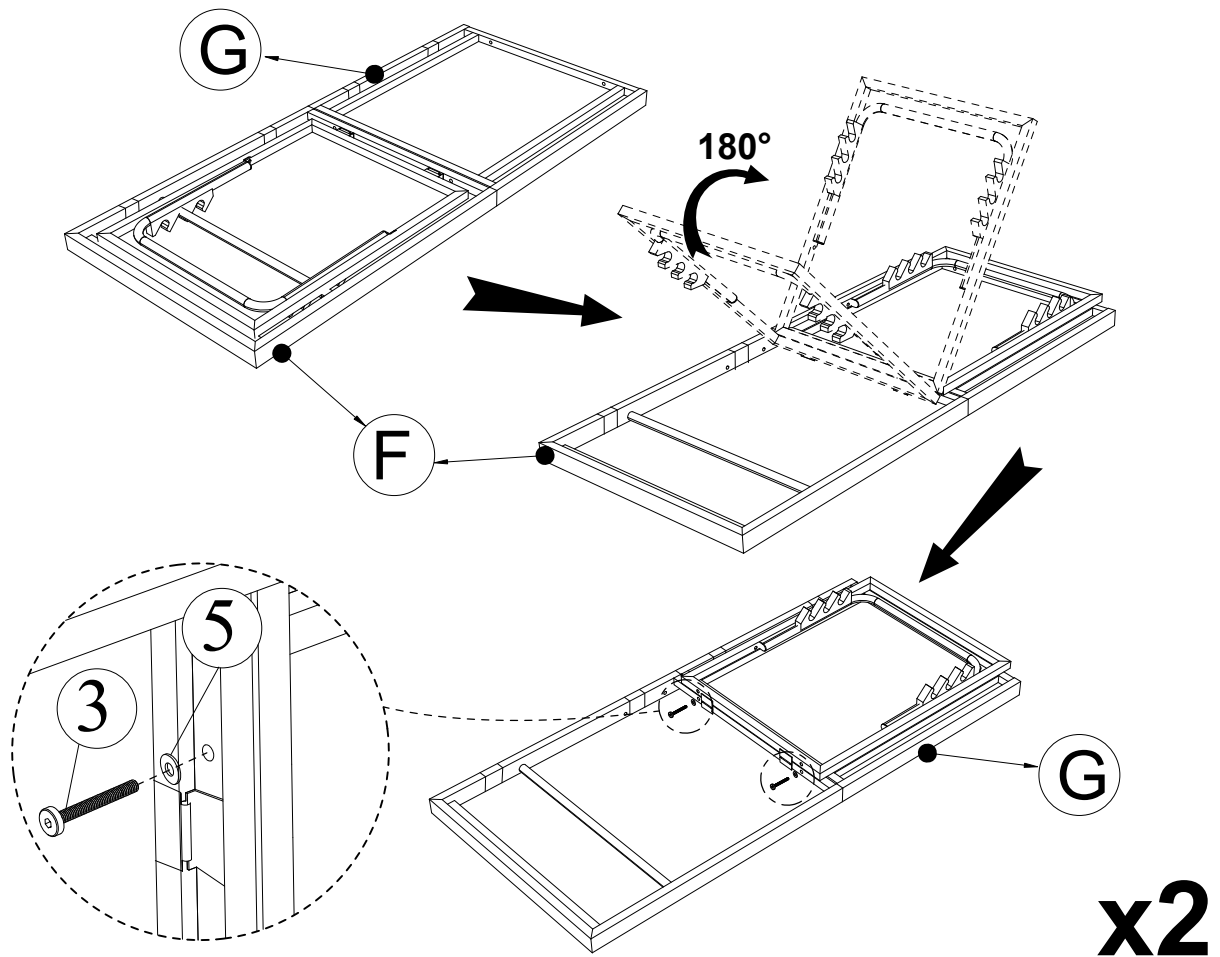

Put Seat Bench 1 (F) next to Seat Bench 2 (G). Turn the inner parts of (F) with 180°. Push Bolts (3) & Washer (5) into holes.

# STEP 8

Ⓓ x2

Ⓔ x2

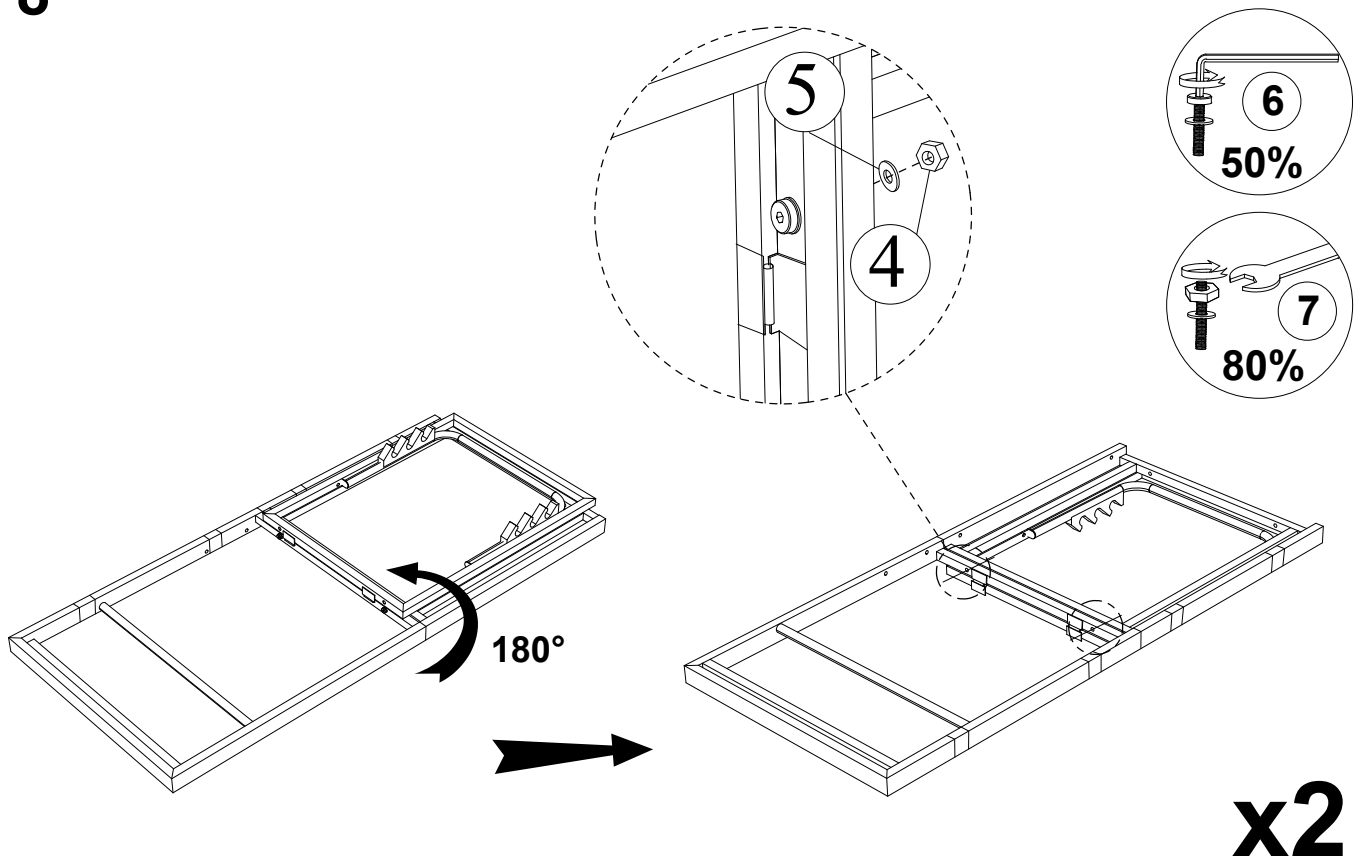

Turn The part from Step 7 downside with 180° & tighten Bolt (3) & Flat Washer (5) & Eru (4) with Allen Key (6), Key (7).

# STEP 9

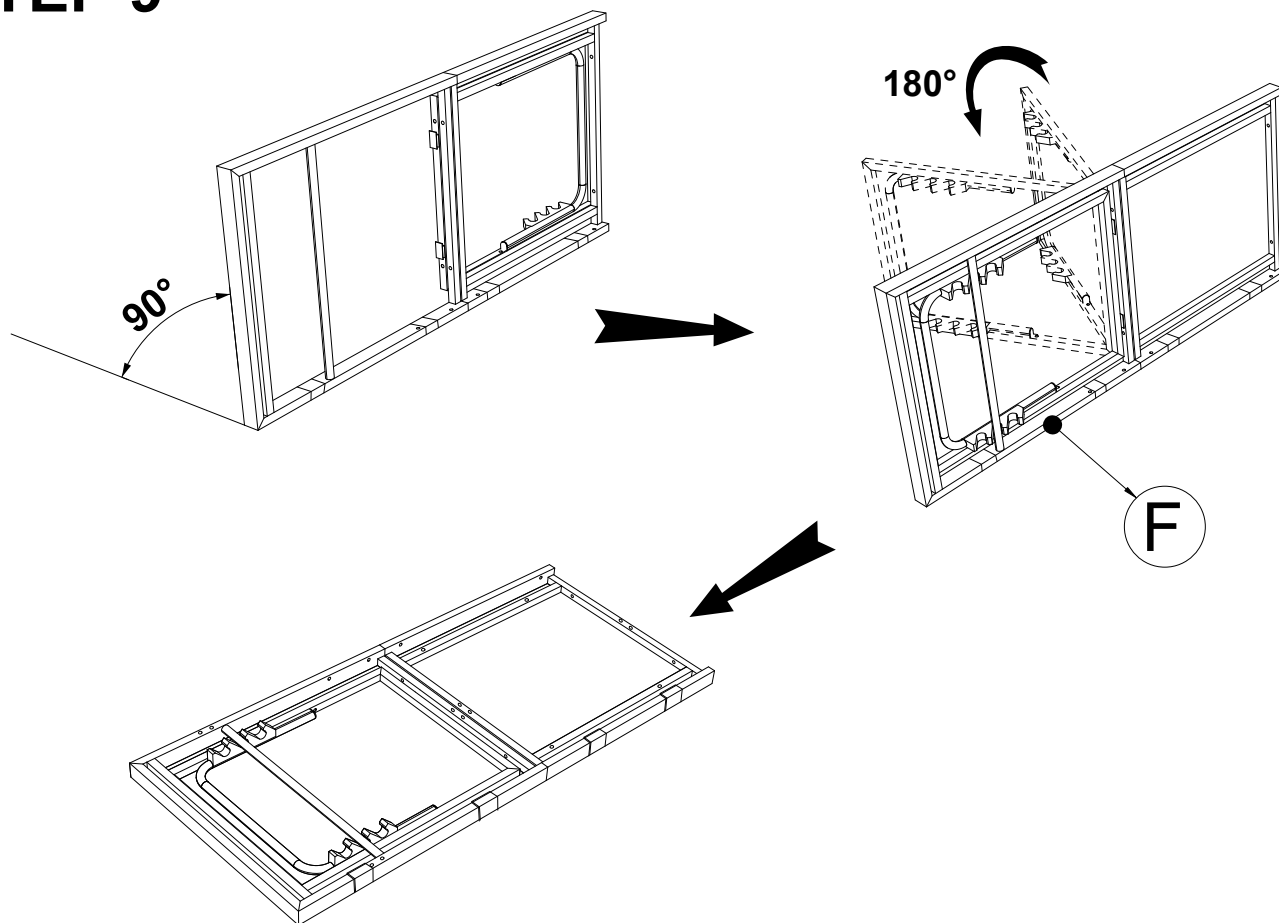

Turn The part from Step 8 with angle 90° & turn the inner part of (F) back to the original position with 180°. Put down all parts

# STEP 10

(H) x1

(3) x2

(4) x2

(5) x4

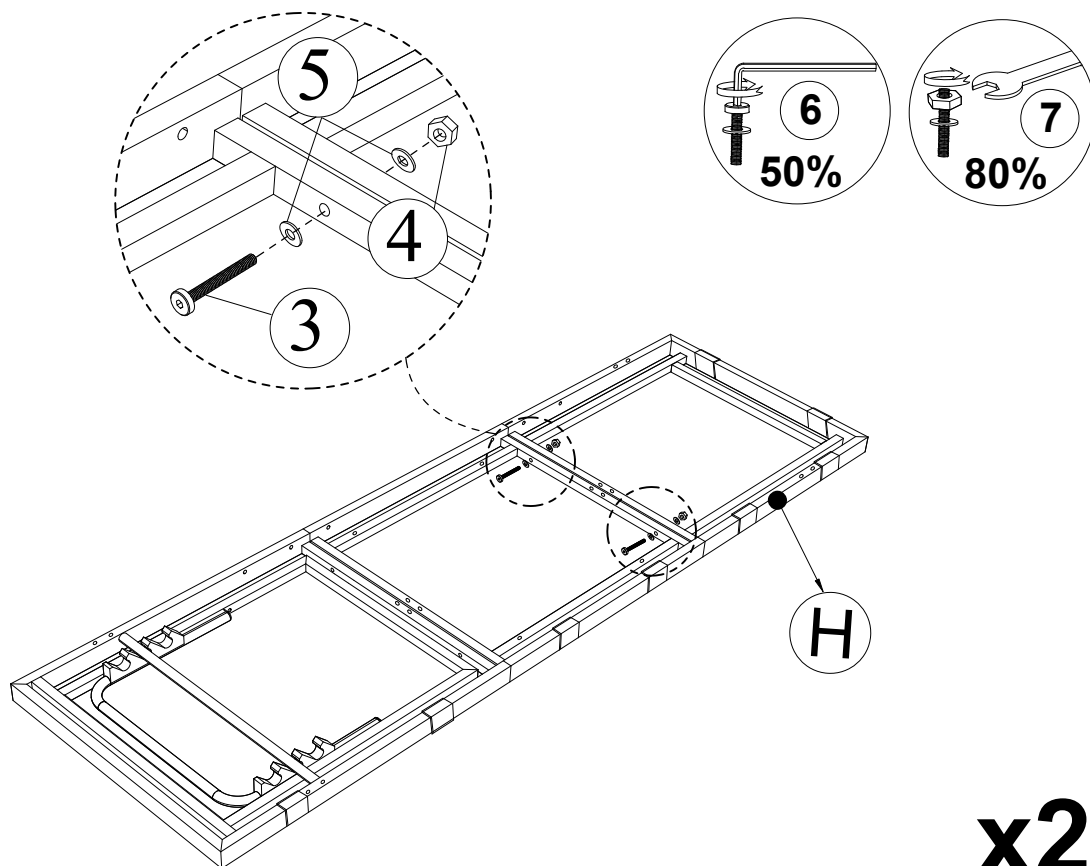

Connect The part from Step 9 & Seat Bench 3 (H) , tighten Bolt (4) & Flat Washer (5) & Nut (4) with Allen Key (6) & Key (7).

# STEP 11

**(M)** x2

**(2)** x12

**(5)** x12

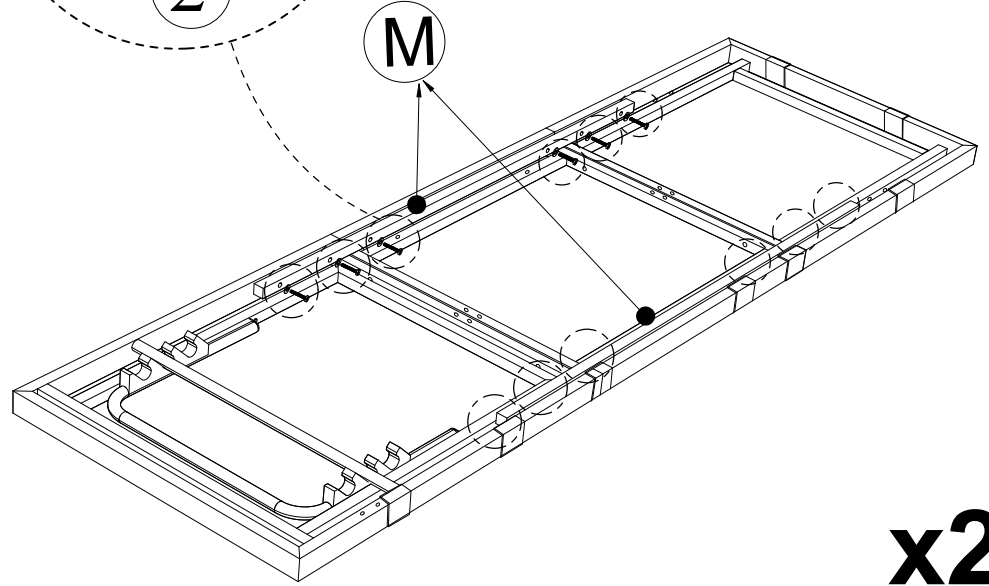
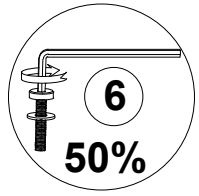
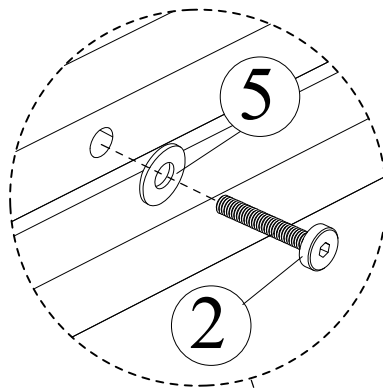

**x2**

Connect The part from Step 10 & Connecting Bar (M), tighten Bolt (2) & Flat Washer (5) with Allen Key (6).

# STEP 12

**(E)** x1

**(2)** x4

**(5)** x4

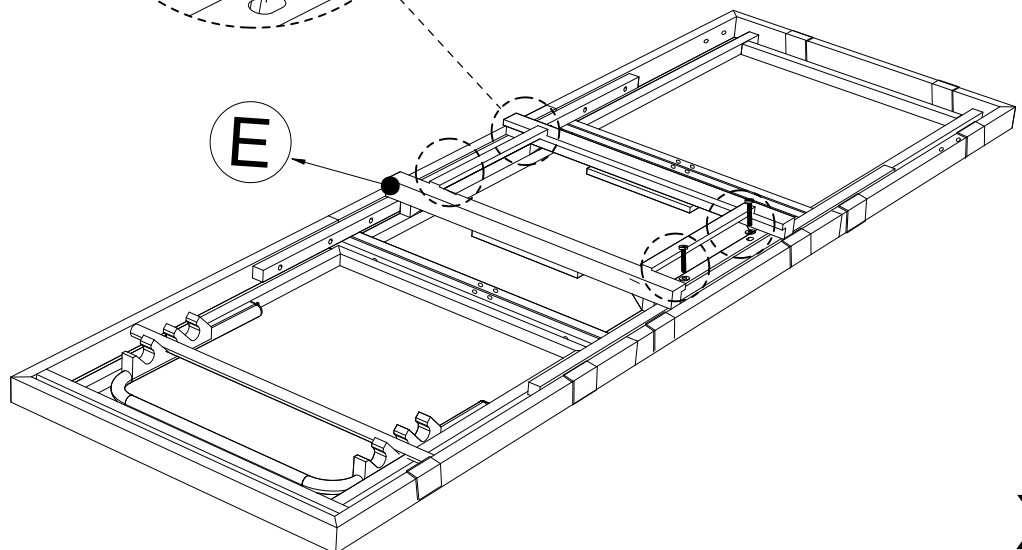
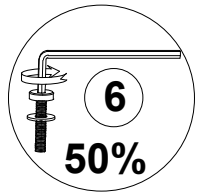
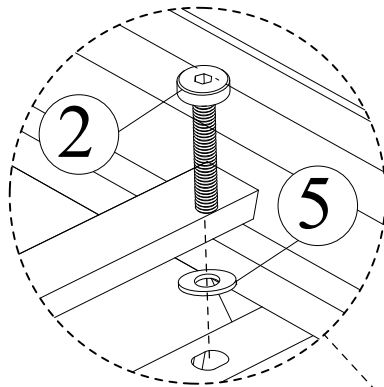

**x2**

Connect The part from Step 11 & Wooden Tray (E), tighten Bolt (2) & Flat Washer (5) with Allen Key (6).

# STEP 13

**J** x1

**K** x1

**10** x8

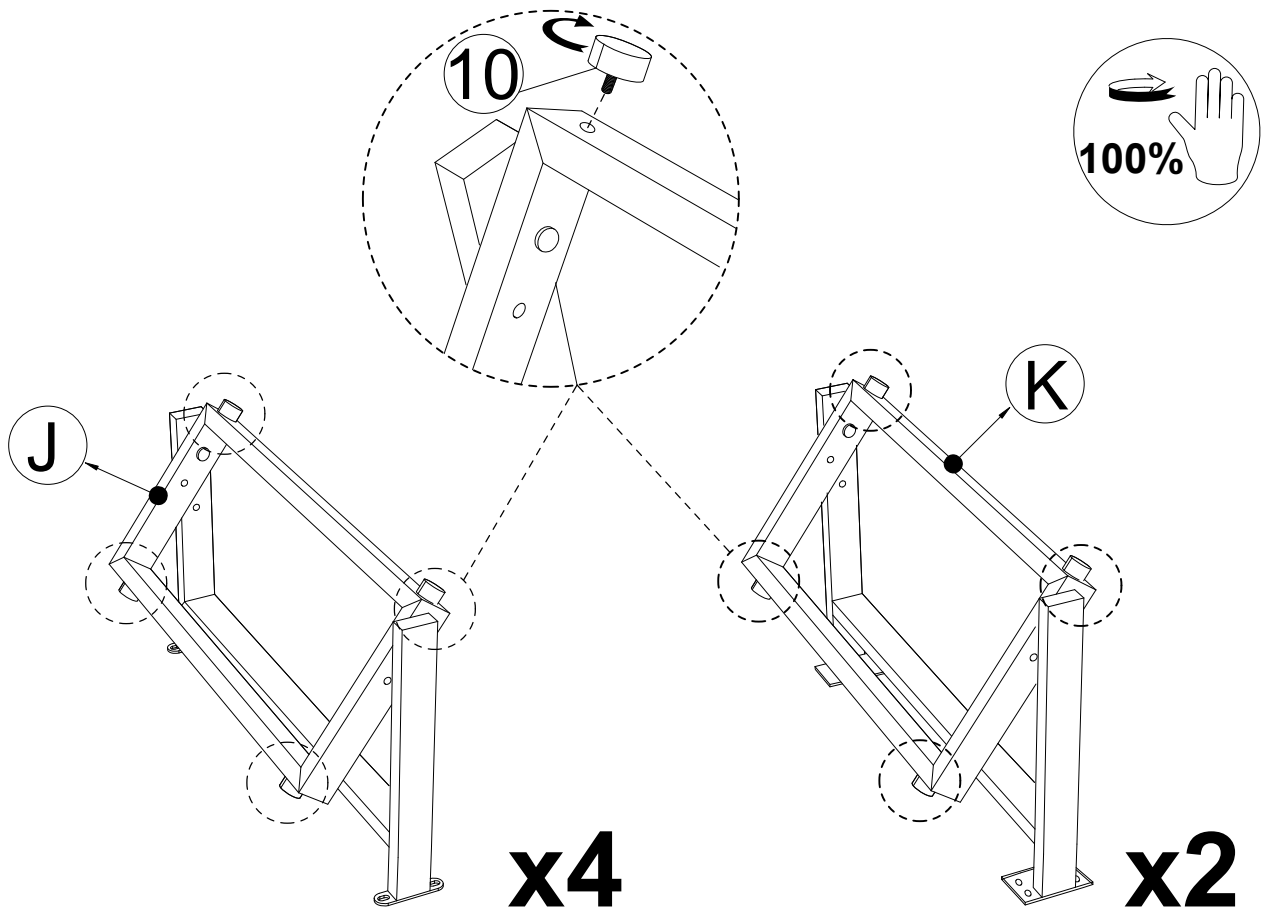

Attach Adjustable Level Leg (10) & Leg Bench (J) & Support Leg (K), tighten The details with hand .

# STEP 14

**1** x8

**5** x8

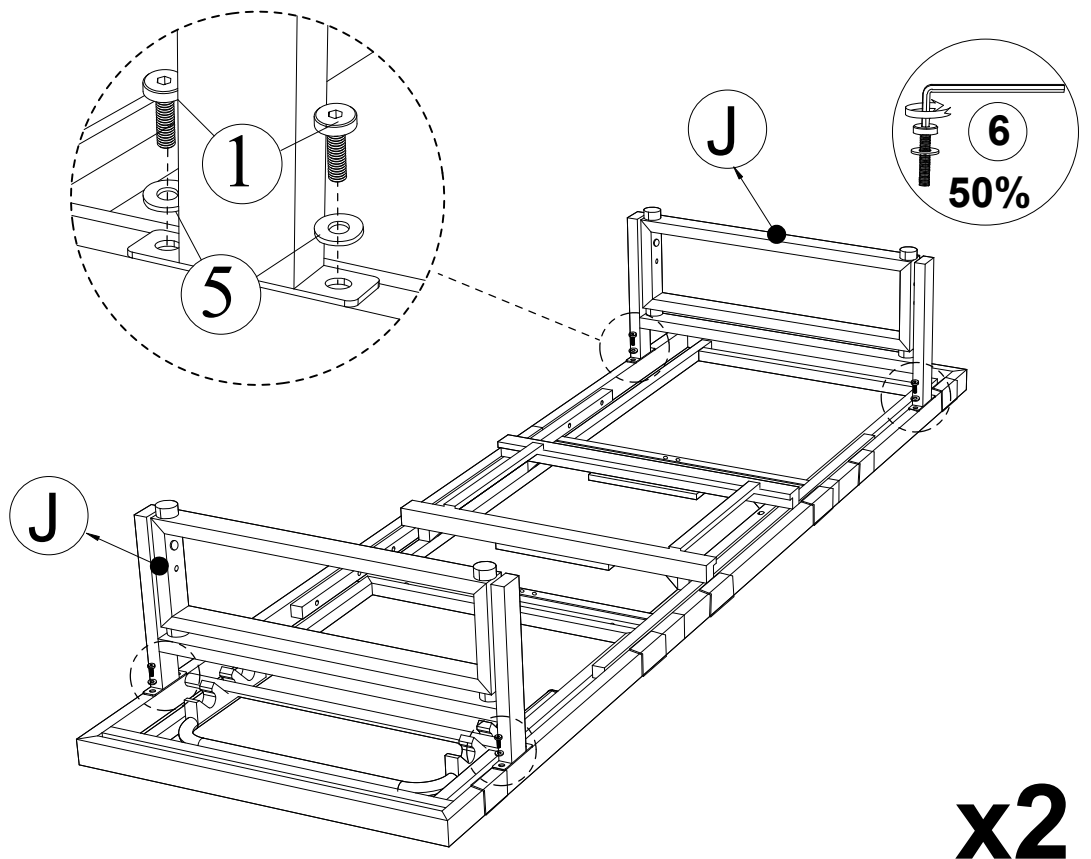

Connect The part from Step 12 & Legs Bench (J) from step 13, tighten Bolt (1) & Flat Washer (5) with Allen Key (6).

# STEP 15

① x8

⑤ x8

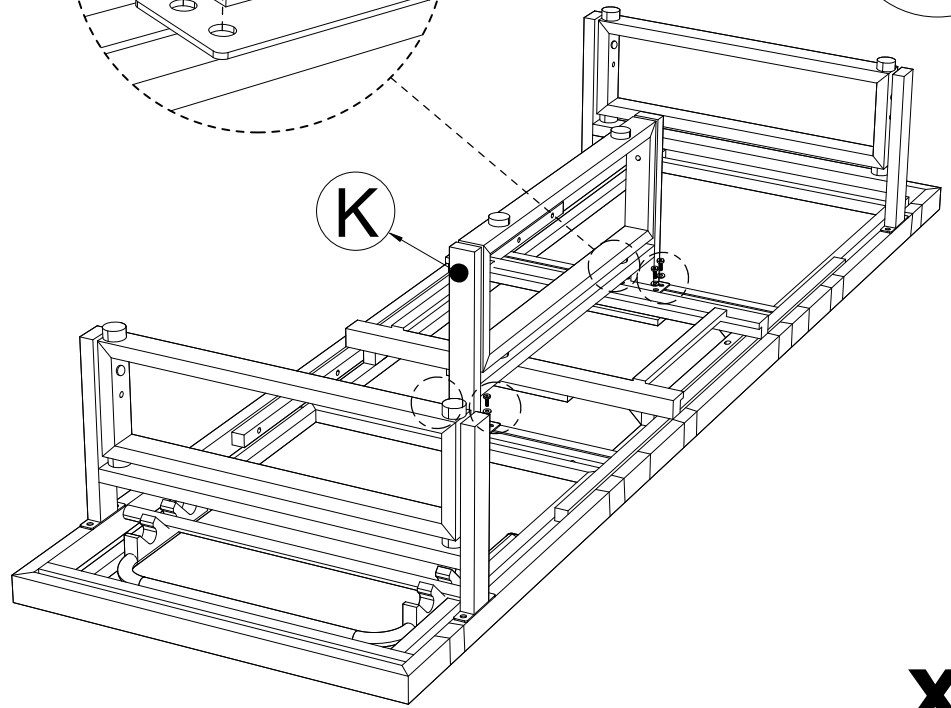
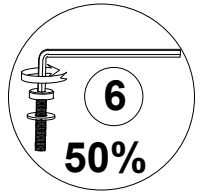
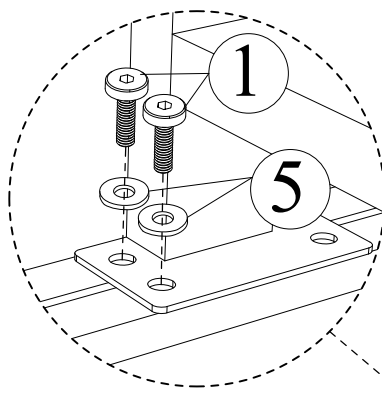

x2

Connect The part from Step 14 & Support Leg (K) from step 13, tighten Bolt (1) & Flat Washer (5) with Allen Key (6).

# STEP 16

⑧ x6

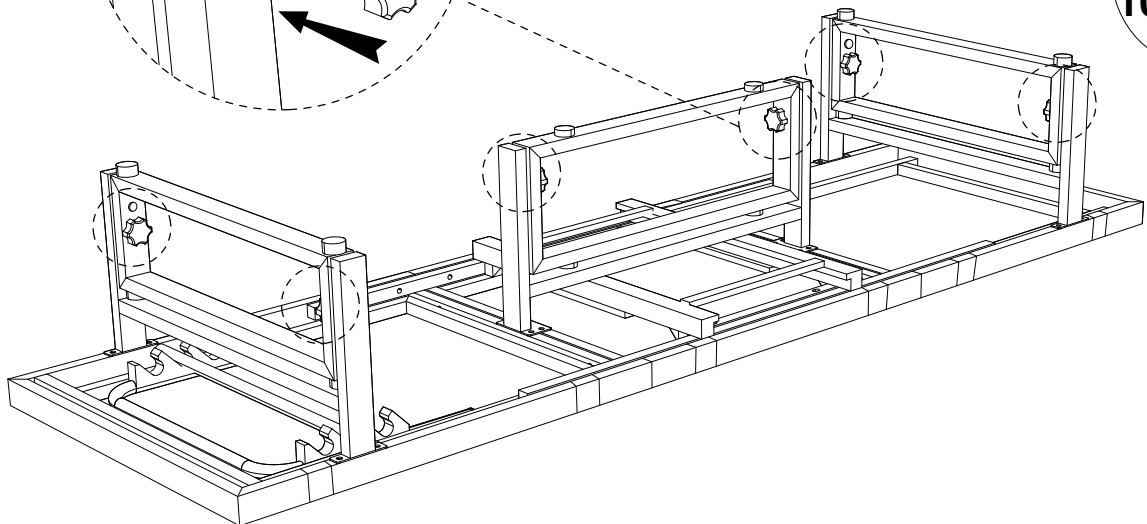
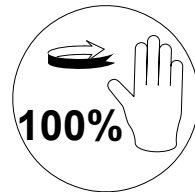
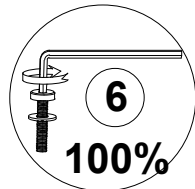
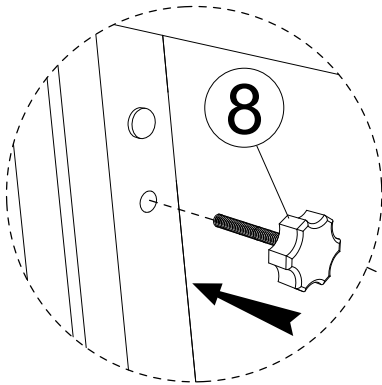

x2

Hold The original sharp of all legs, tighten Fixed Bolt (8) with hand. Firmly tighten Bolts with Allen Key (5) & Hand

# STEP 17

① x6

FABRIC COVERS

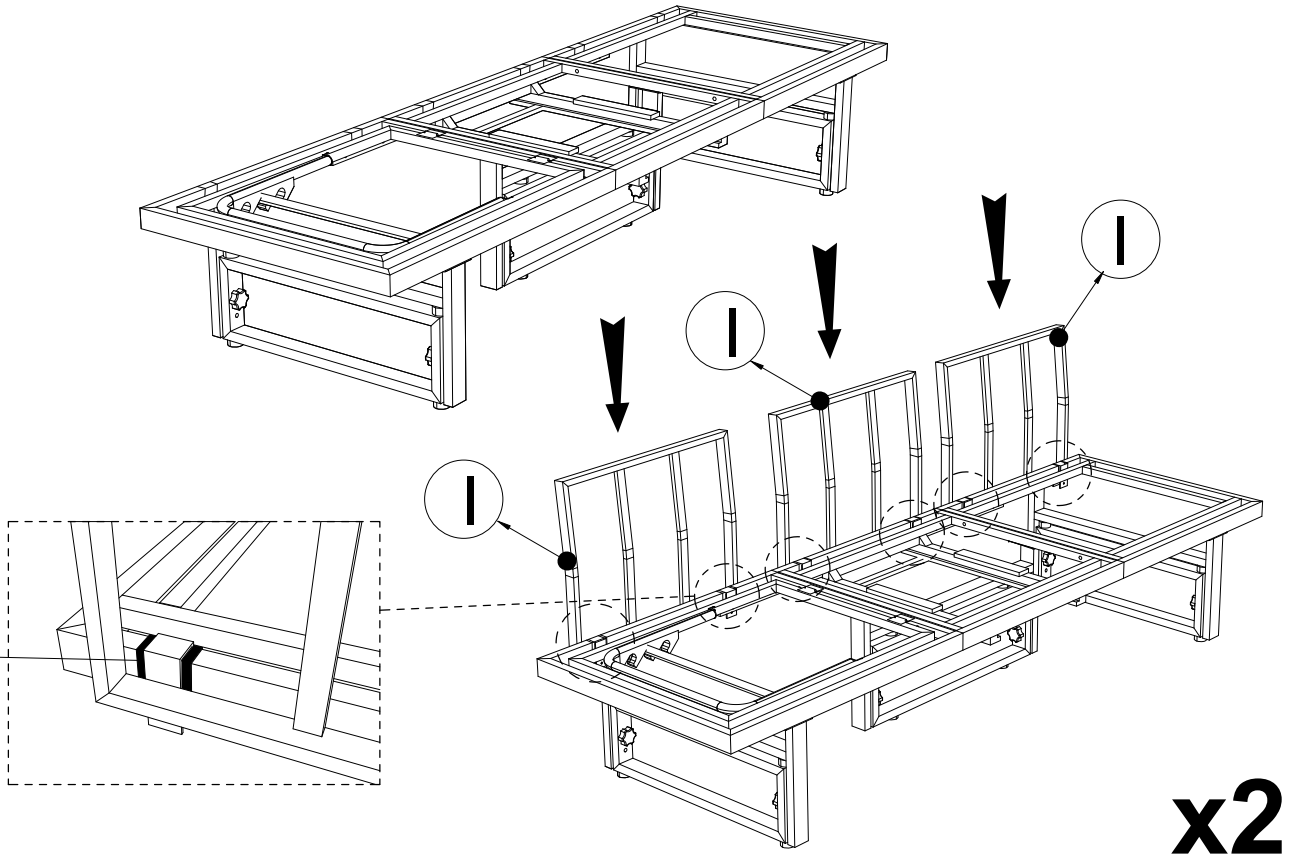

x2

Put Bench upright & Push Back Bench (1) on to the right position that have the fabric covers

# STEP 18

⑧ x6

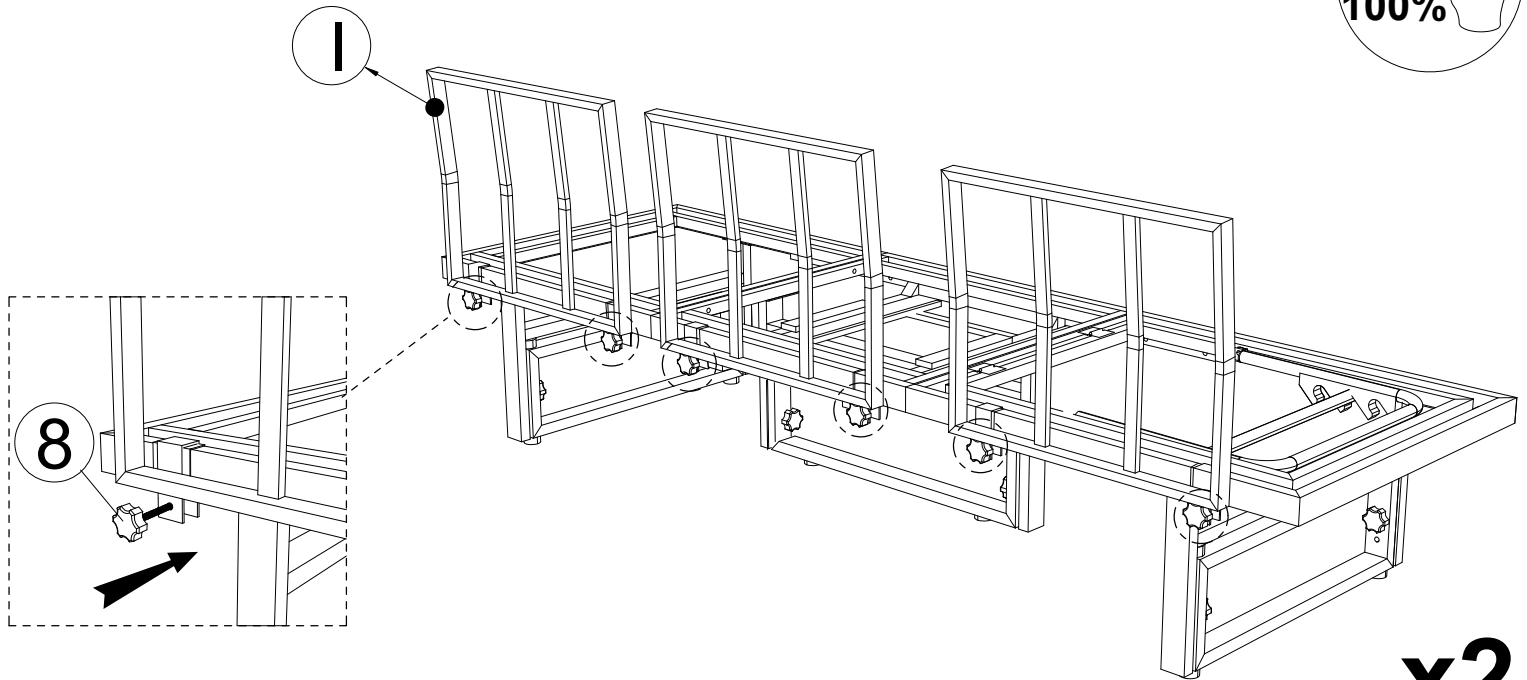

x2

Hold & tighten Fixed Bolt (8) with hand



# STEP 19A

Modify the height of Leg Bench

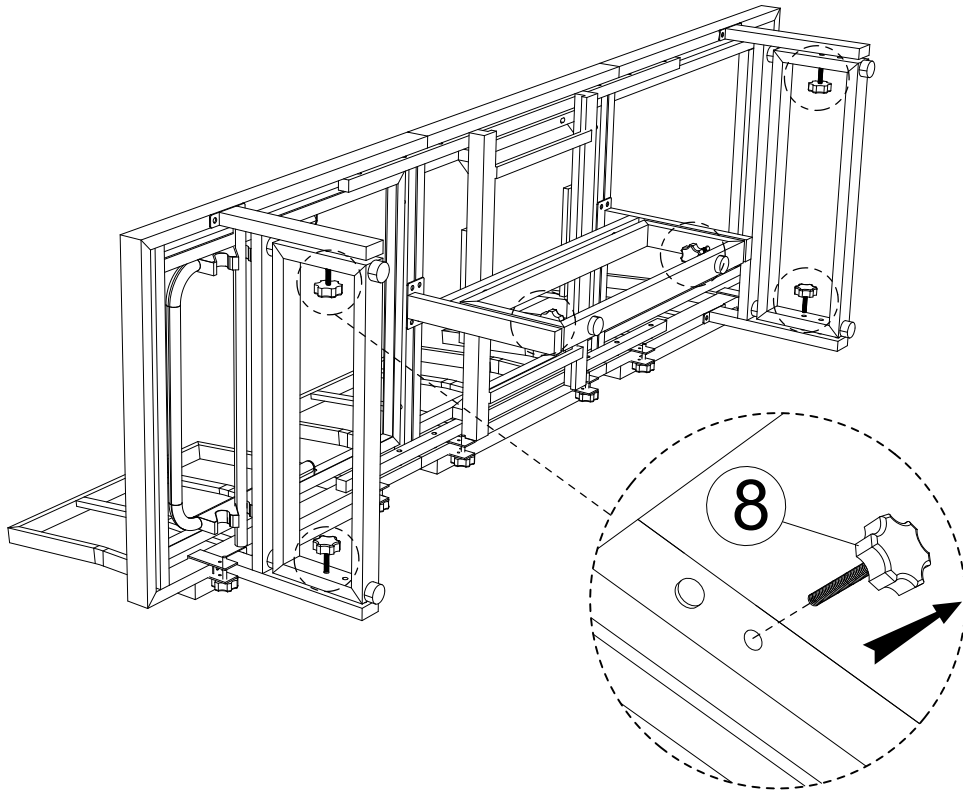
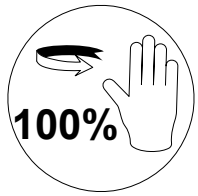

x2

Loosen & remove Fixed Bolt (8)

# STEP 19B

Modify the height of Leg Bench

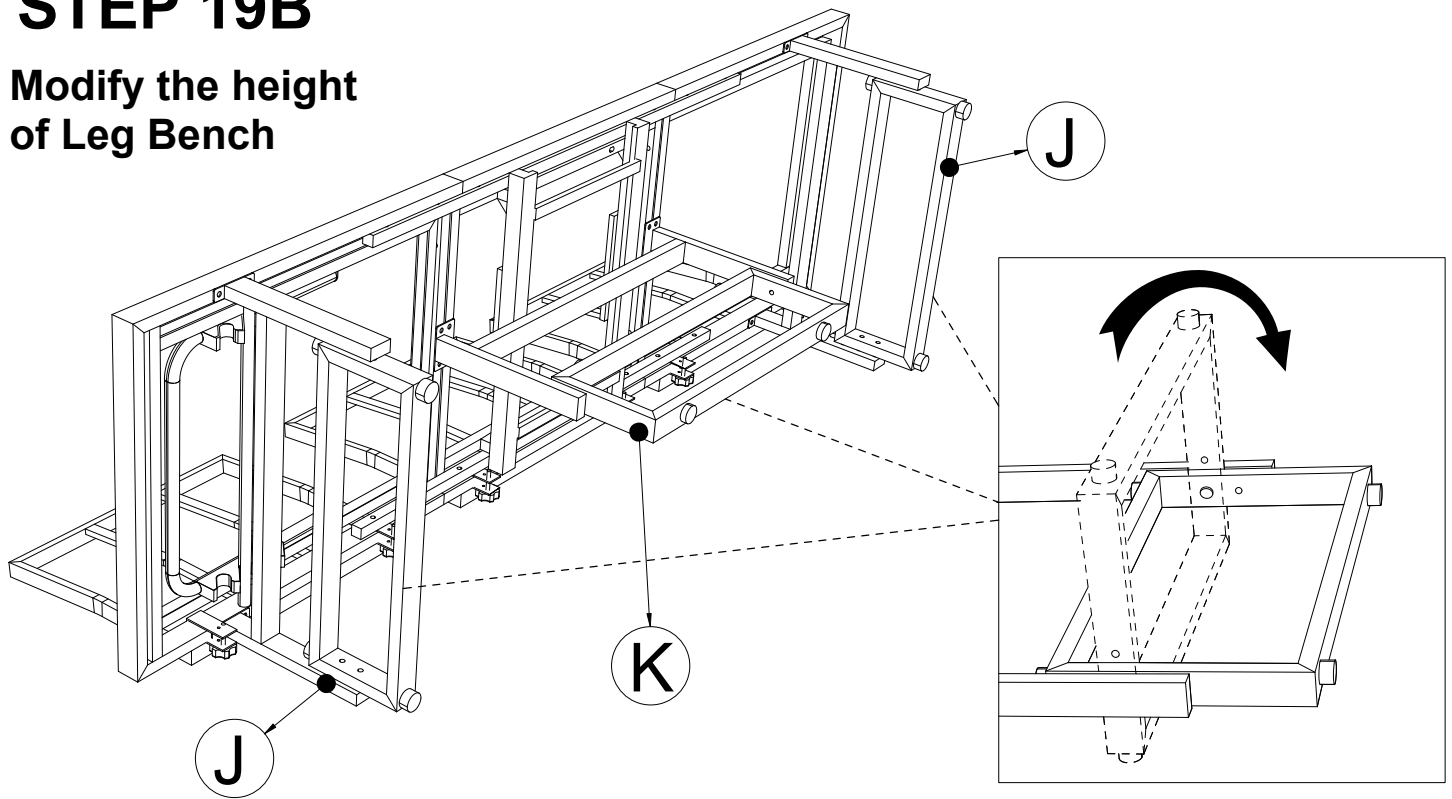

x2

Rotate the inner part of (J) & (K) with the angle 180°

## STEP 19C

Modify the height  
of Leg Bench

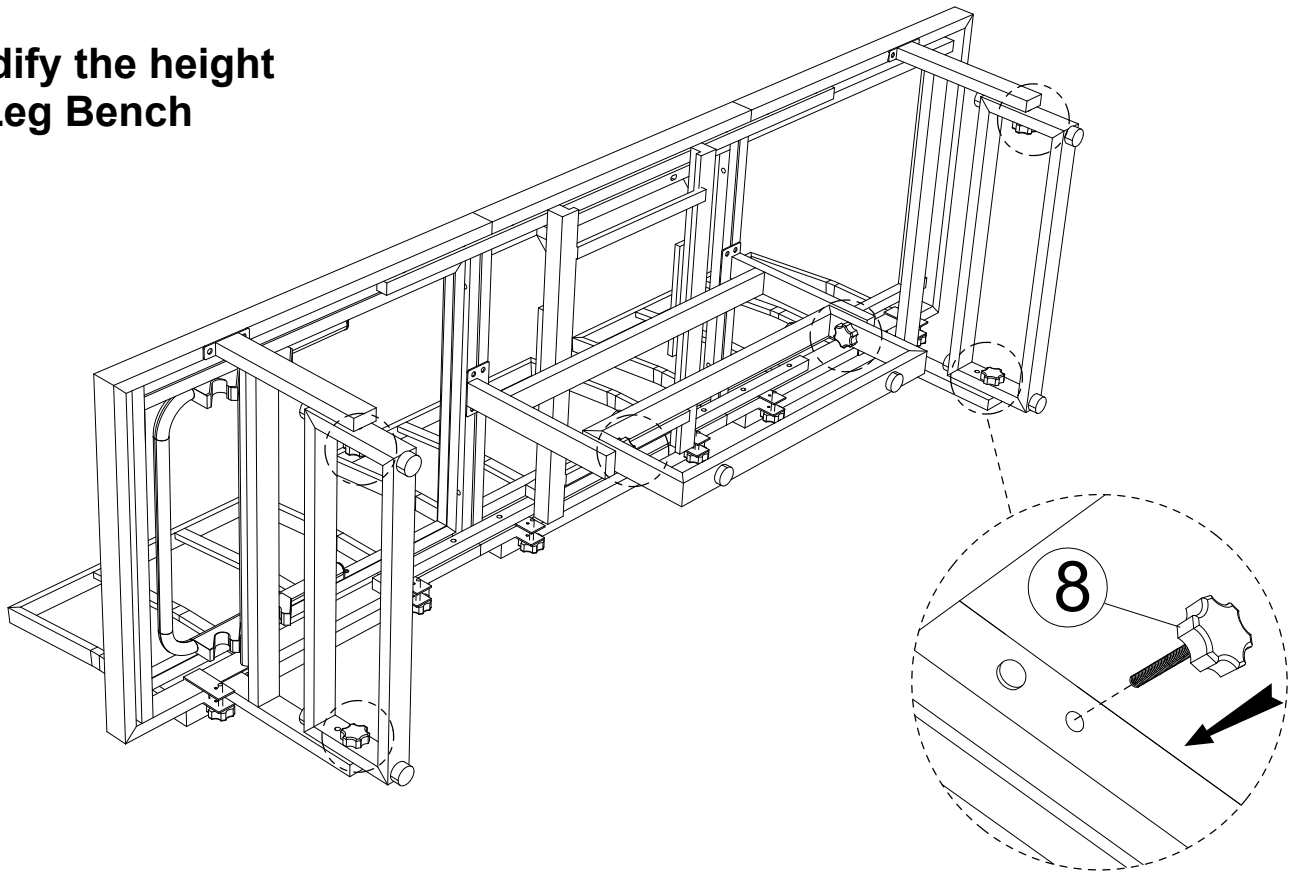

**x2**

Tighten Fixed Bolt (8) with hand

## STEP 19D

Modify the height  
of Leg Bench

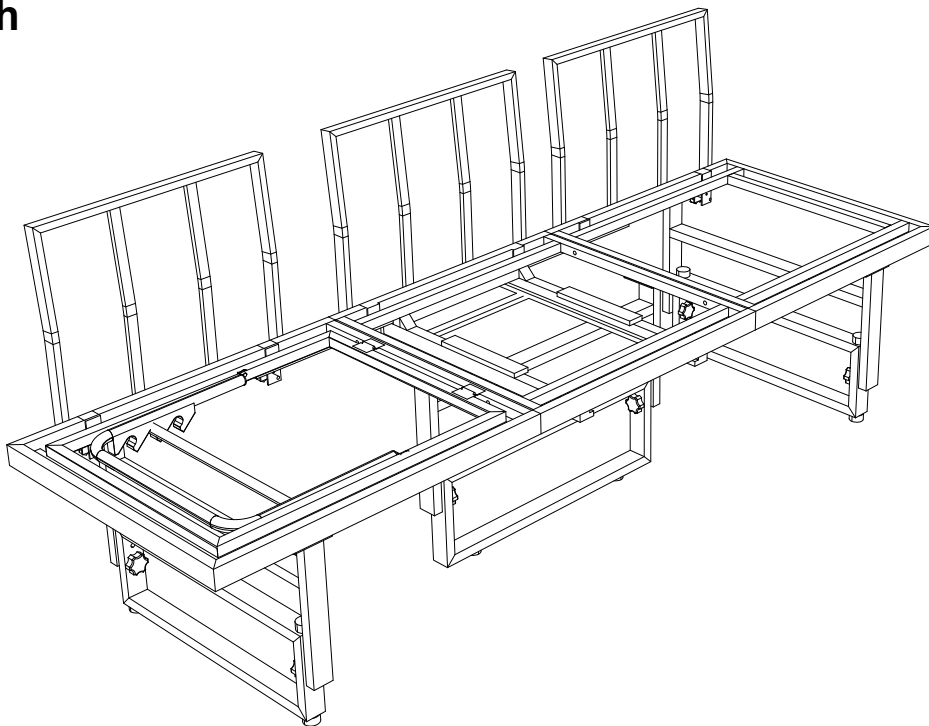

**x2**

Finish the heigher the Bench Frame

# STEP 20

**(S)** x1

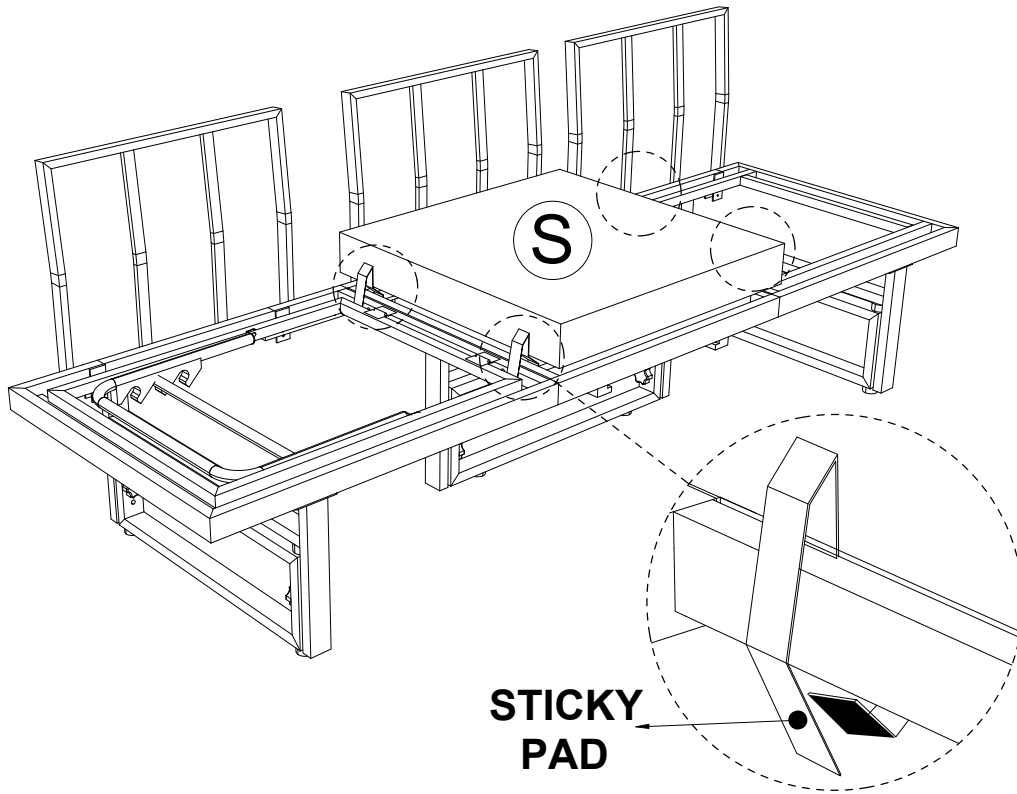

Set up the Cushion (S) on to the Seat Bench 2 (G) from the step 18 with sticky pads.

# STEP 21

**(N)** x2

**(O)** x1

**(P)** x1

**(X)** x1

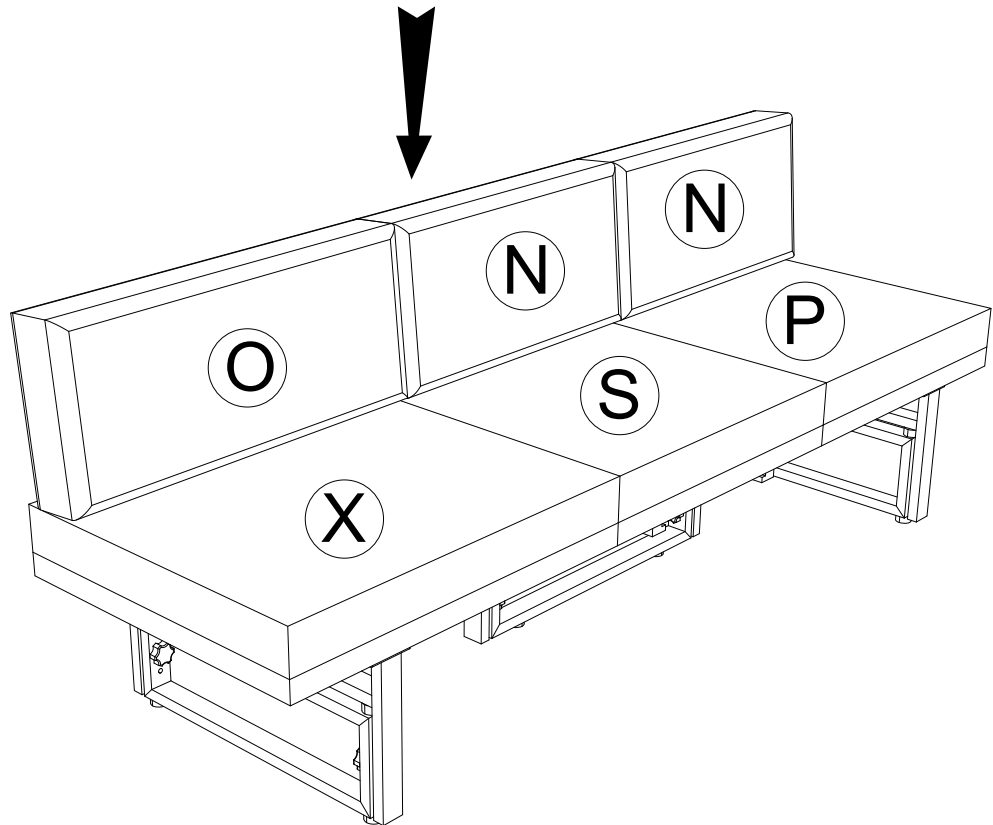

Set up the Cushions (N)+(O)+(X)+(P).

# STEP 22

**D** x1

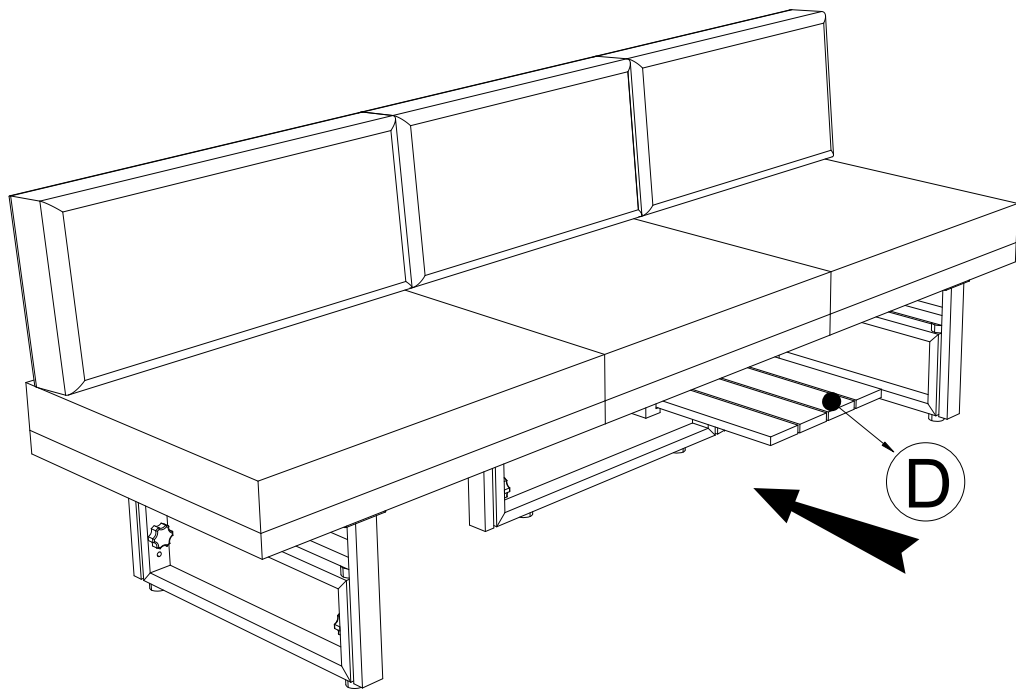

**Put & push the Side table (D) into the Wooden Tray.**

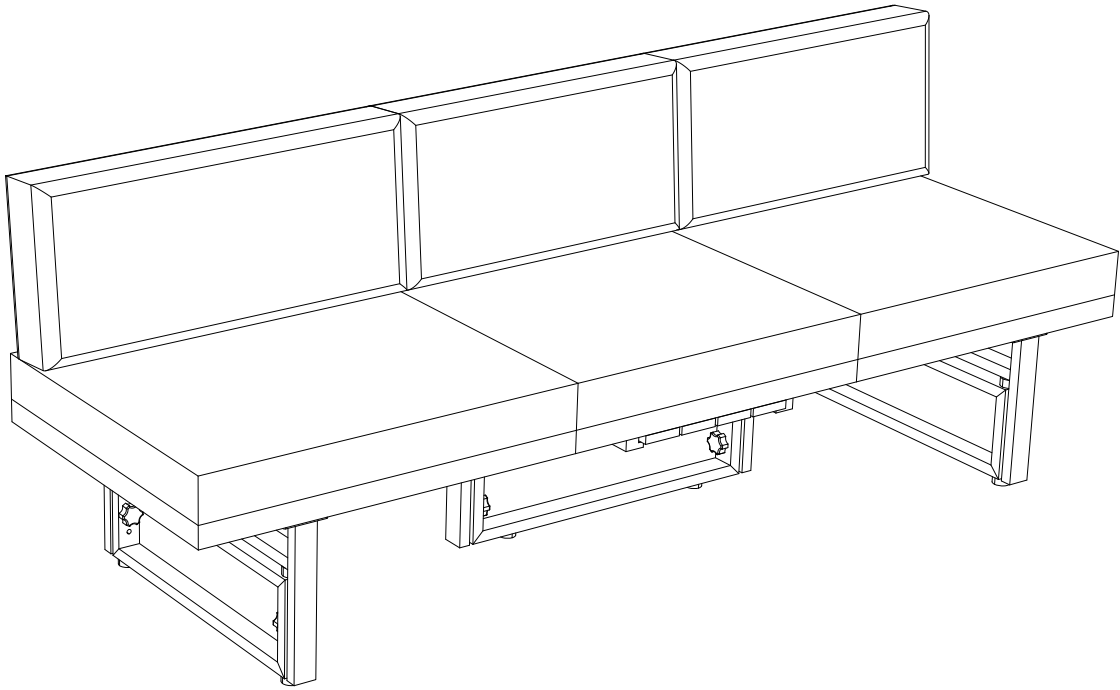

**Finish the Bench**

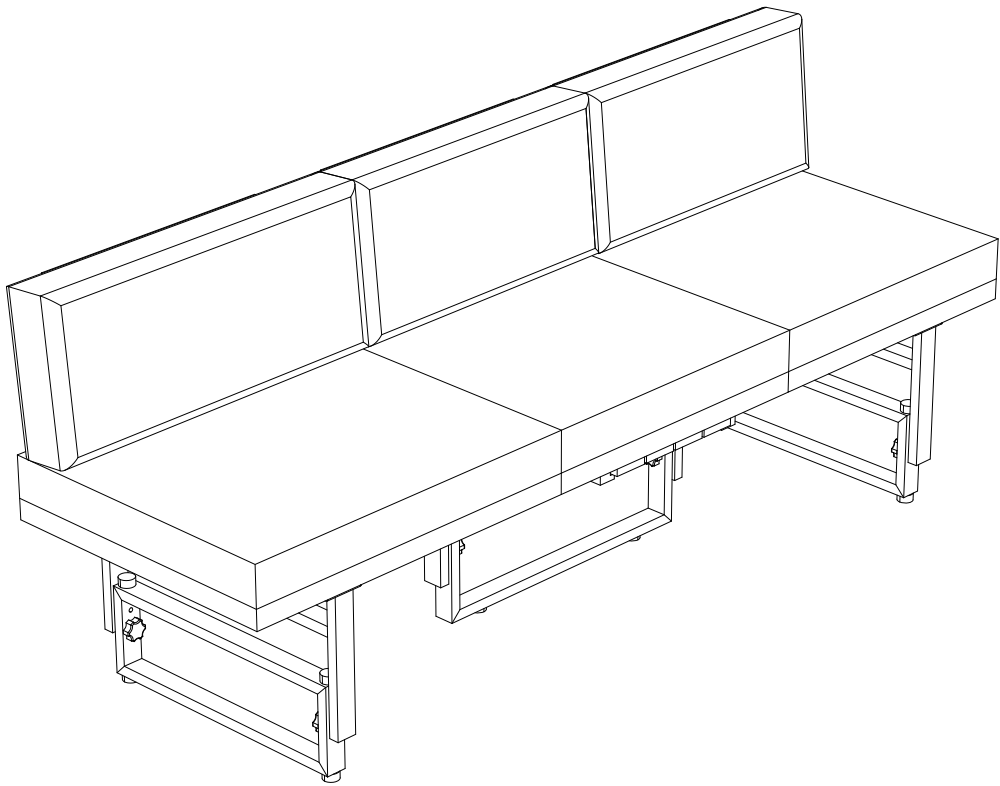

**Finish the heigher Bench**

# STEP 23

Modify the seaters of Bench

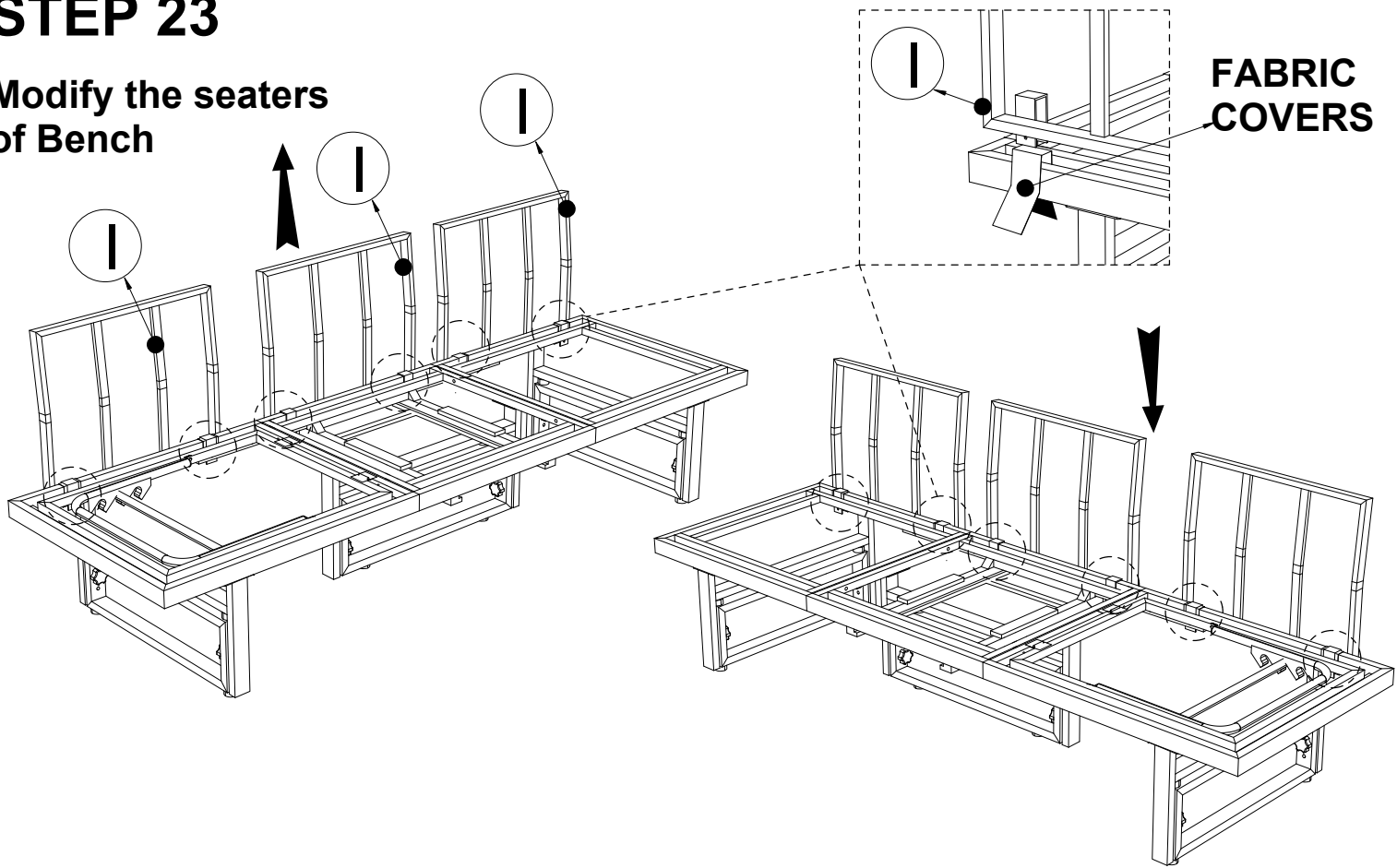

From the step 18, change all Backs Bench (I) with Fabric Covers to the opposite side.

# STEP 24

Modify the seaters of Bench

- Ⓢ x1
- Ⓝ x2
- Ⓞ x1
- Ⓟ x1
- ⓧ x1

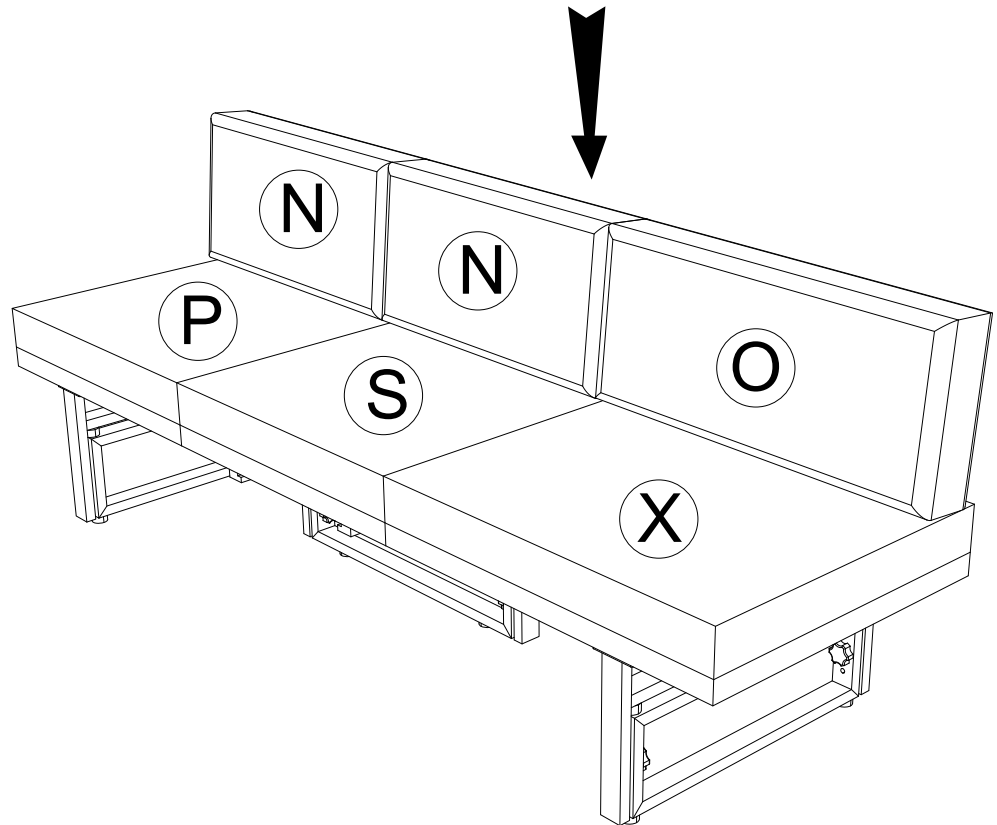

Set up again all the Cushions as same as the step 20 & 21

# STEP 25

**D** x1

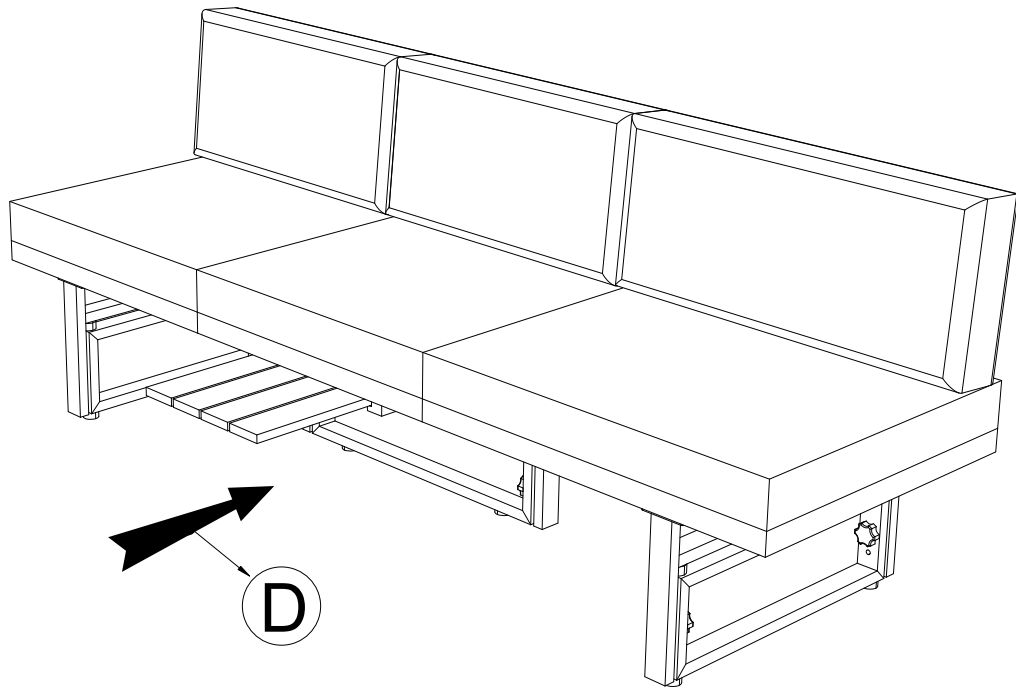

**Put & push the Side table (D) into the Wooden Tray.**

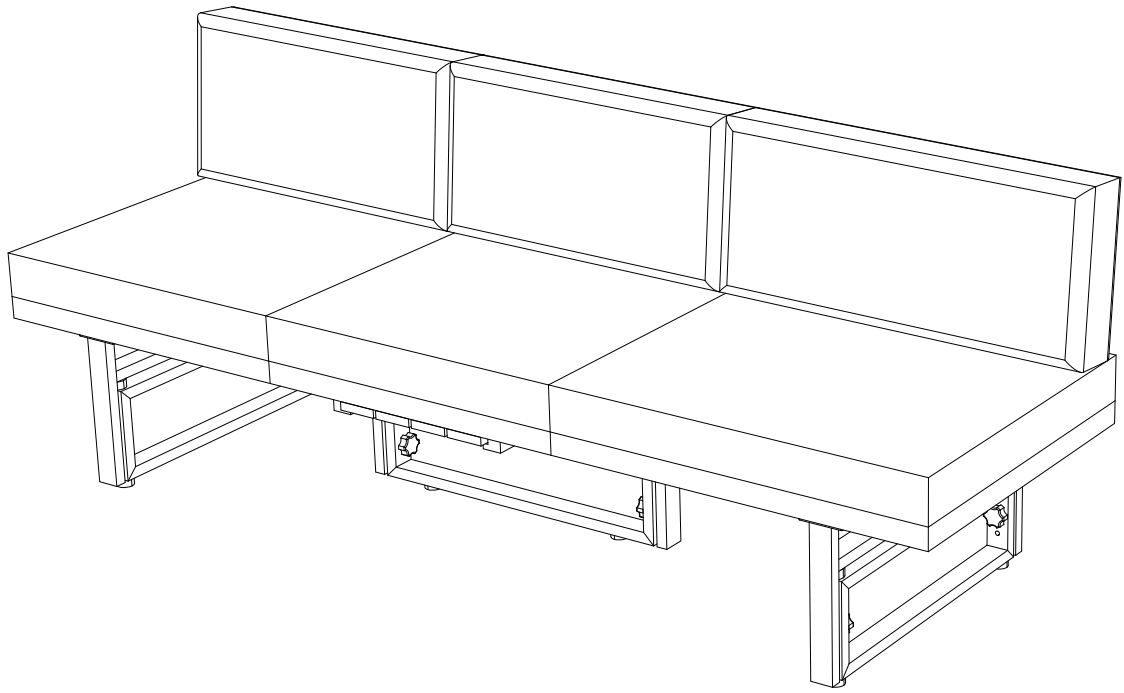

**Finish the Bench**

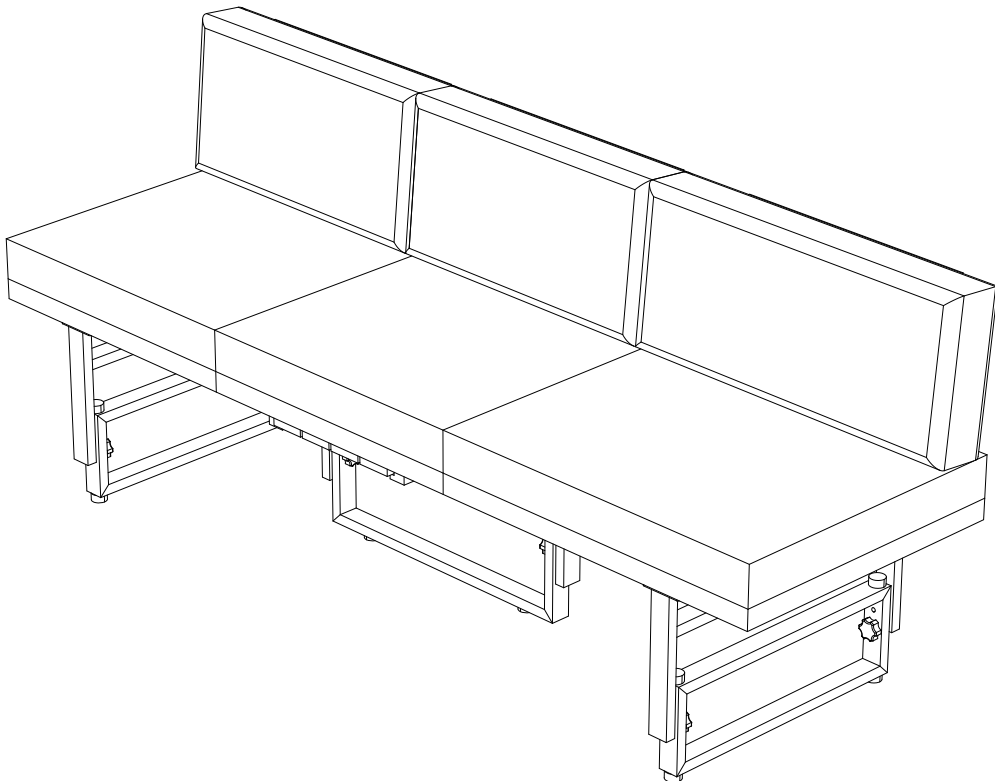

**Finish the heigher Bench**



# STEP 26

Modify the seaters of Bench

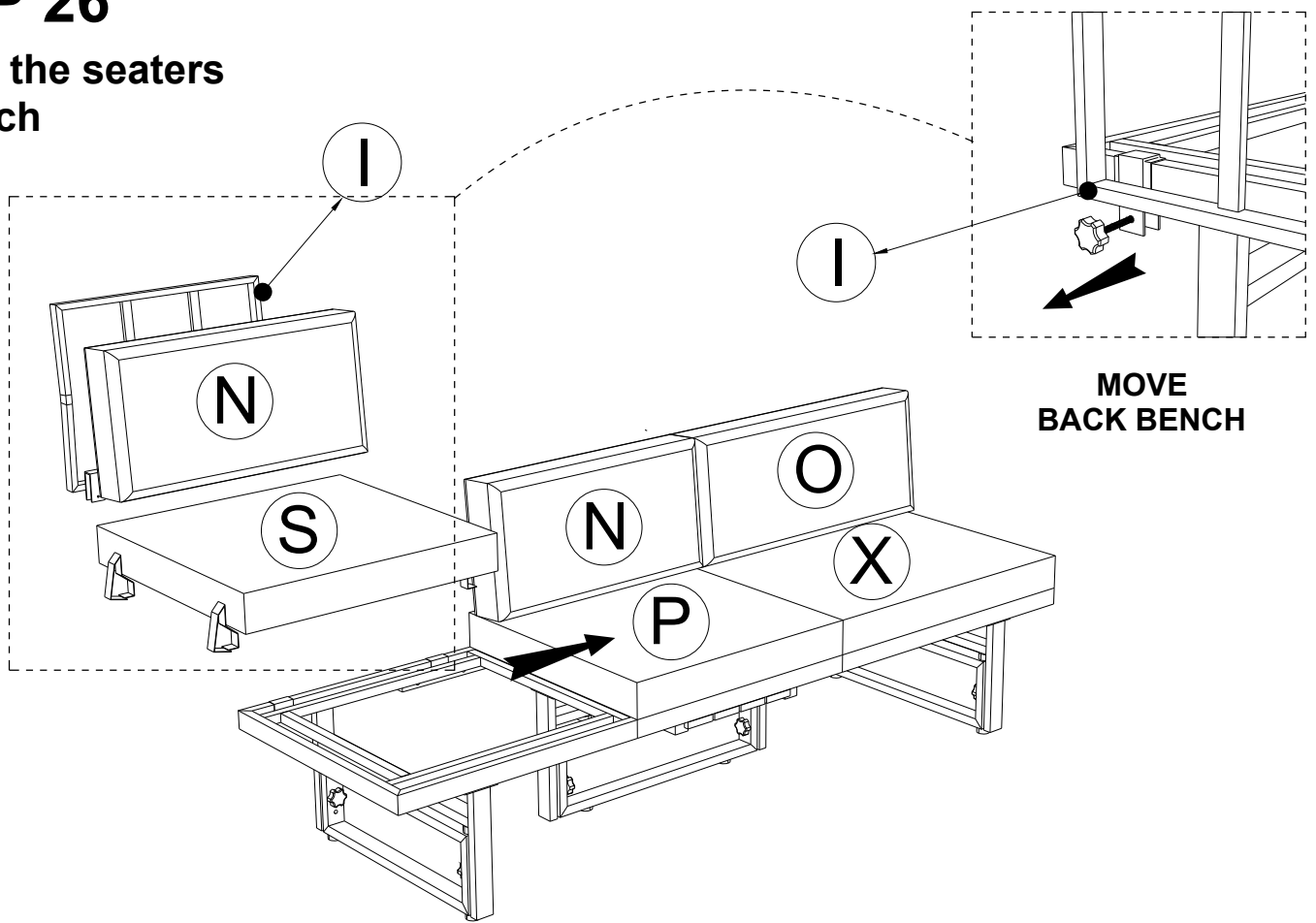

MOVE  
BACK BENCH

Remove some the detail (I)+(N)+(S) & adjust again the cushions

# STEP 27

Modify the seaters of Bench

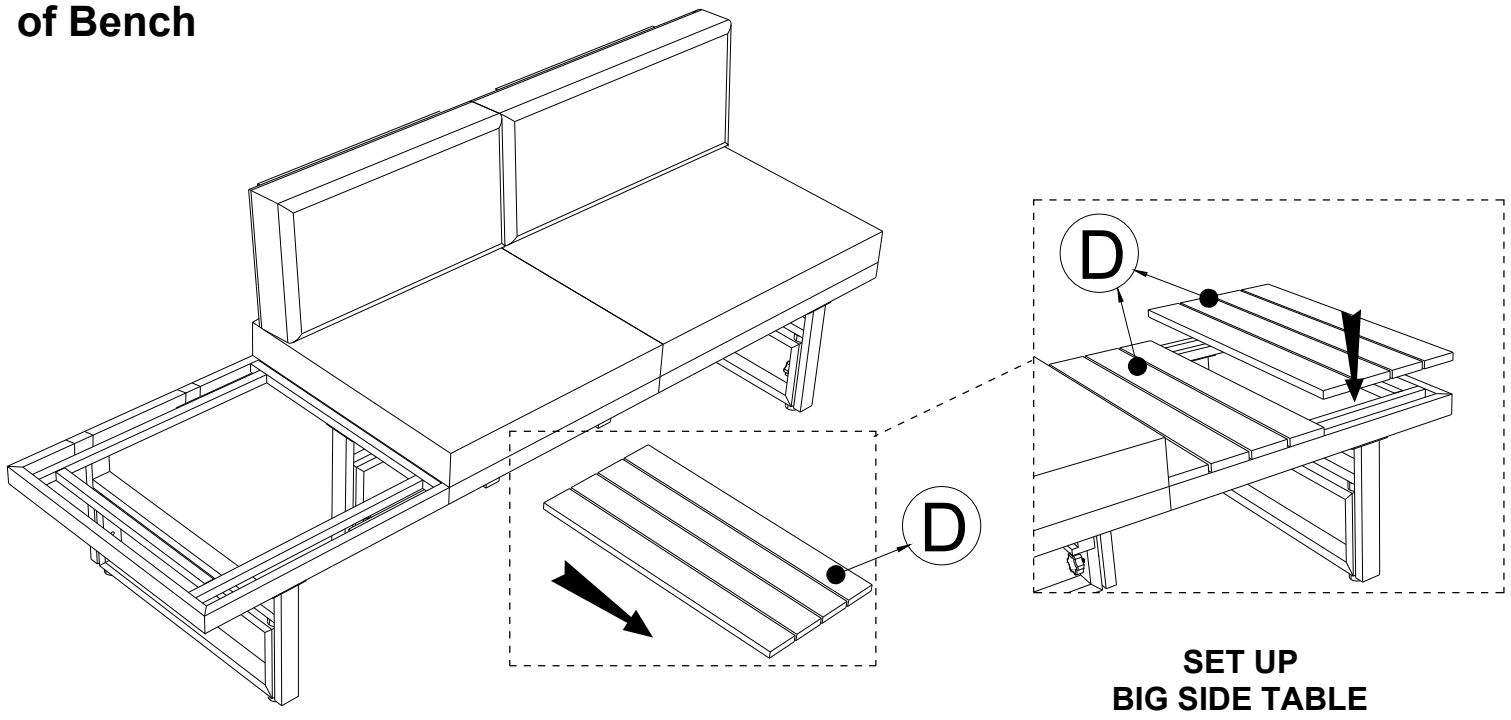

SET UP  
BIG SIDE TABLE

Remove the detail (D) from Benches & connect 2 parts to the big side table.

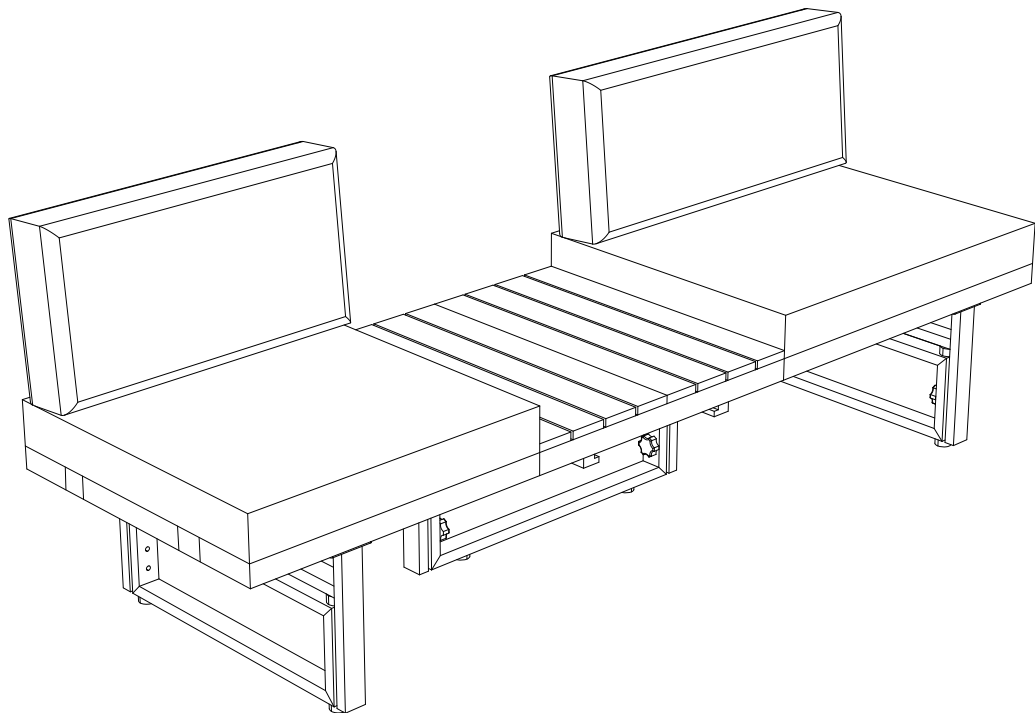
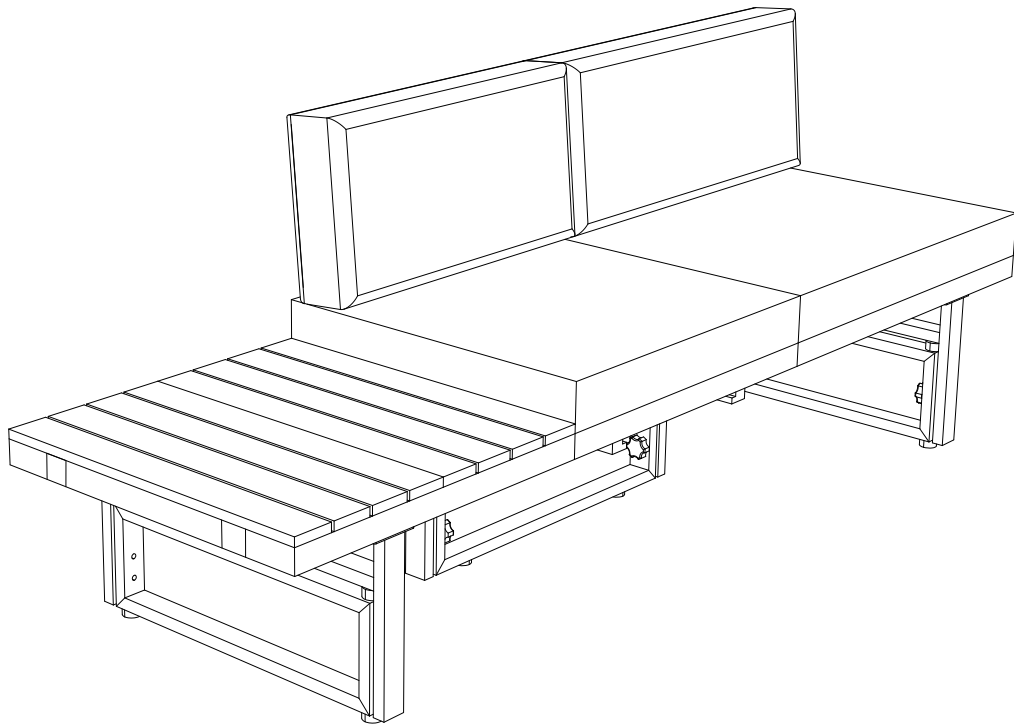

**Finish the Sharp of Bench**

## STEP 28

Modify the seaters  
of Bench

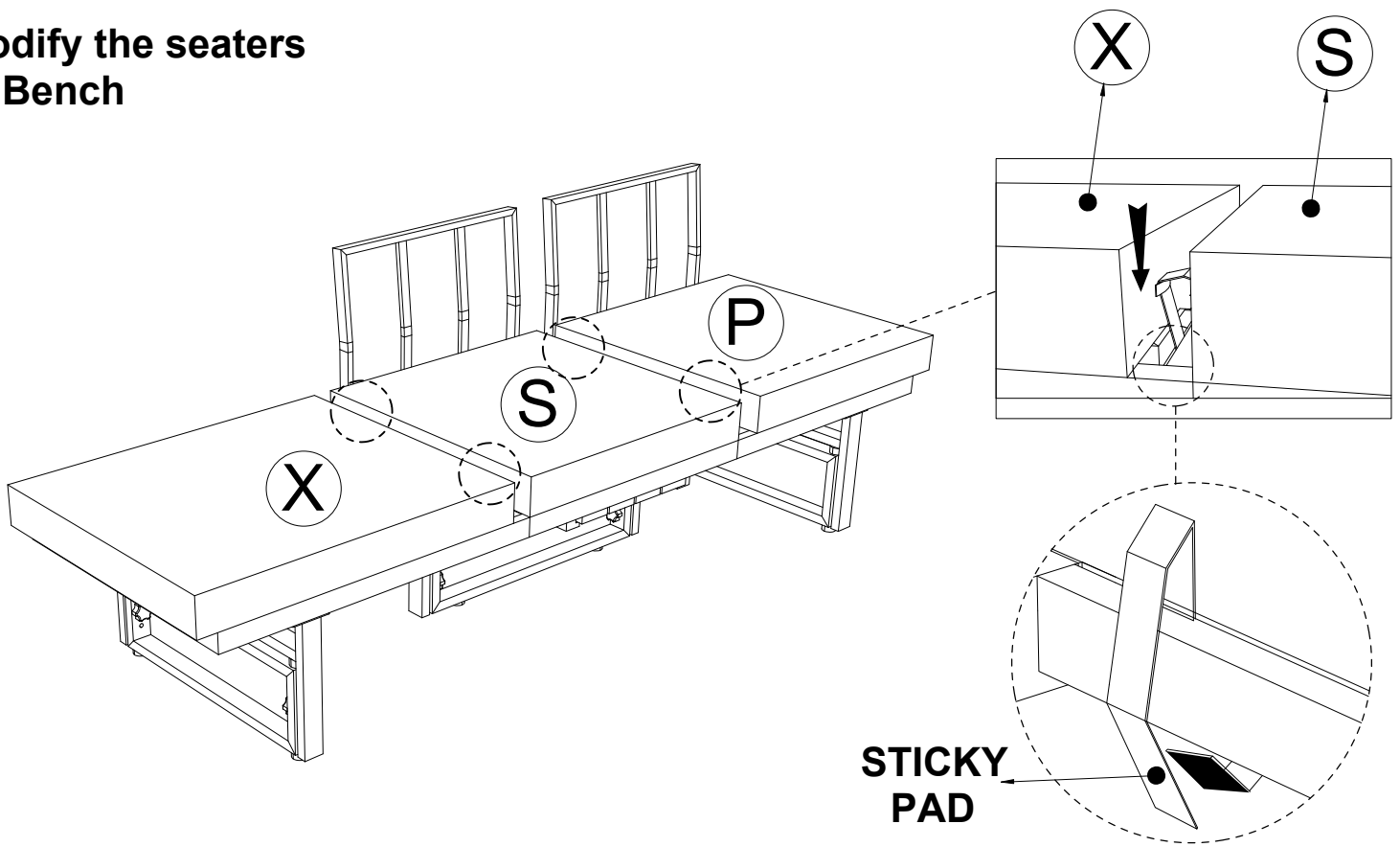

Remove the Cushions (N)

Connect the Cushions (X)+(S)+(P) with sticky pads.

## STEP 29

Modify the seaters  
of Bench

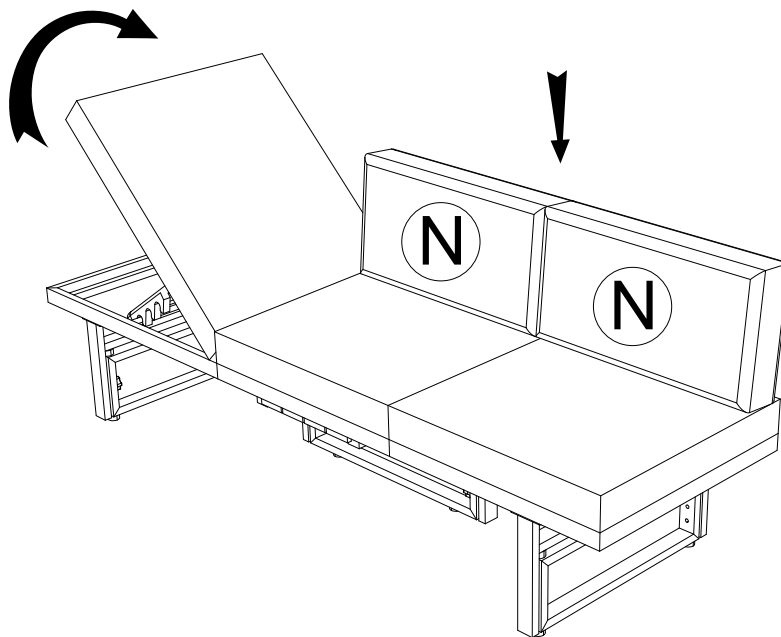

Using the lifting set of part (F) to make the Backrest for finishing bed.  
Set up again the Cushions (N)

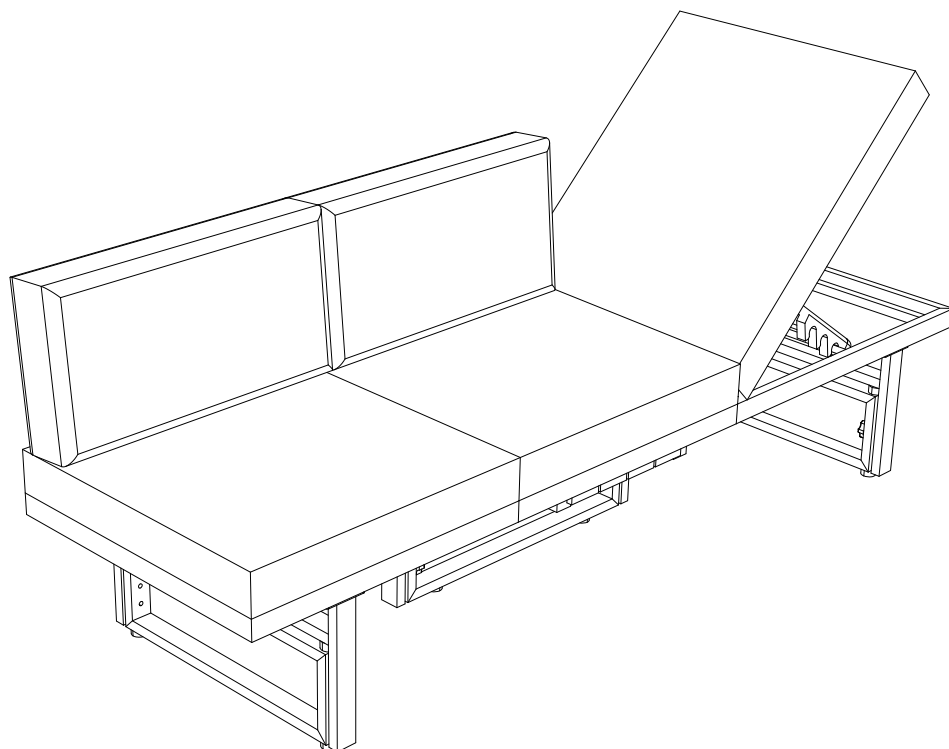
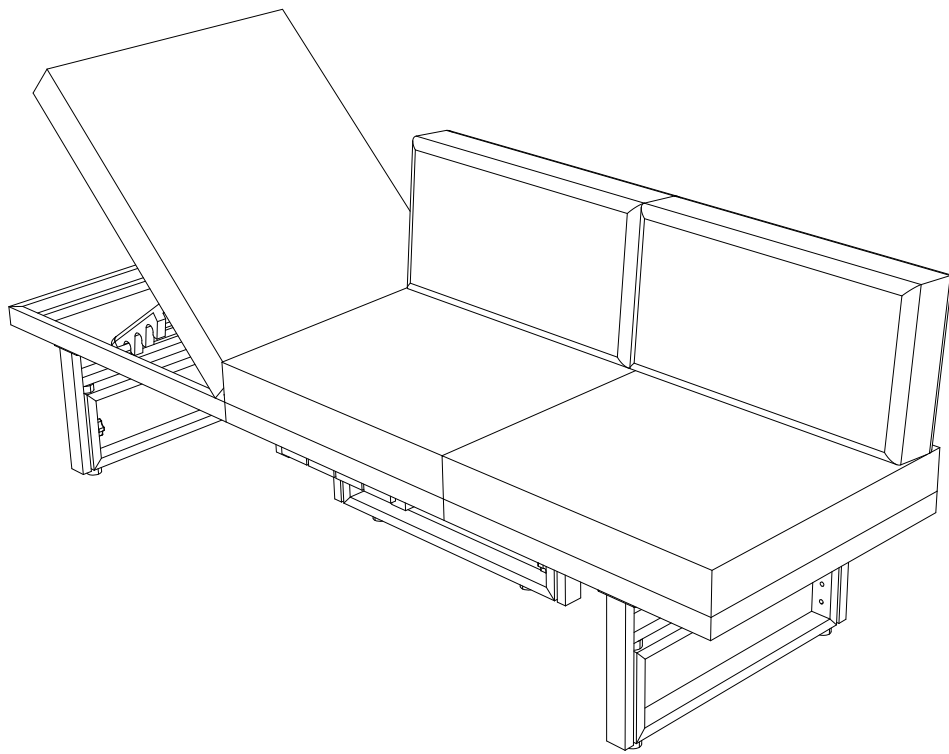

**Finish the Sharp Backrest**

# STEP 30

Modify the seaters of Bench

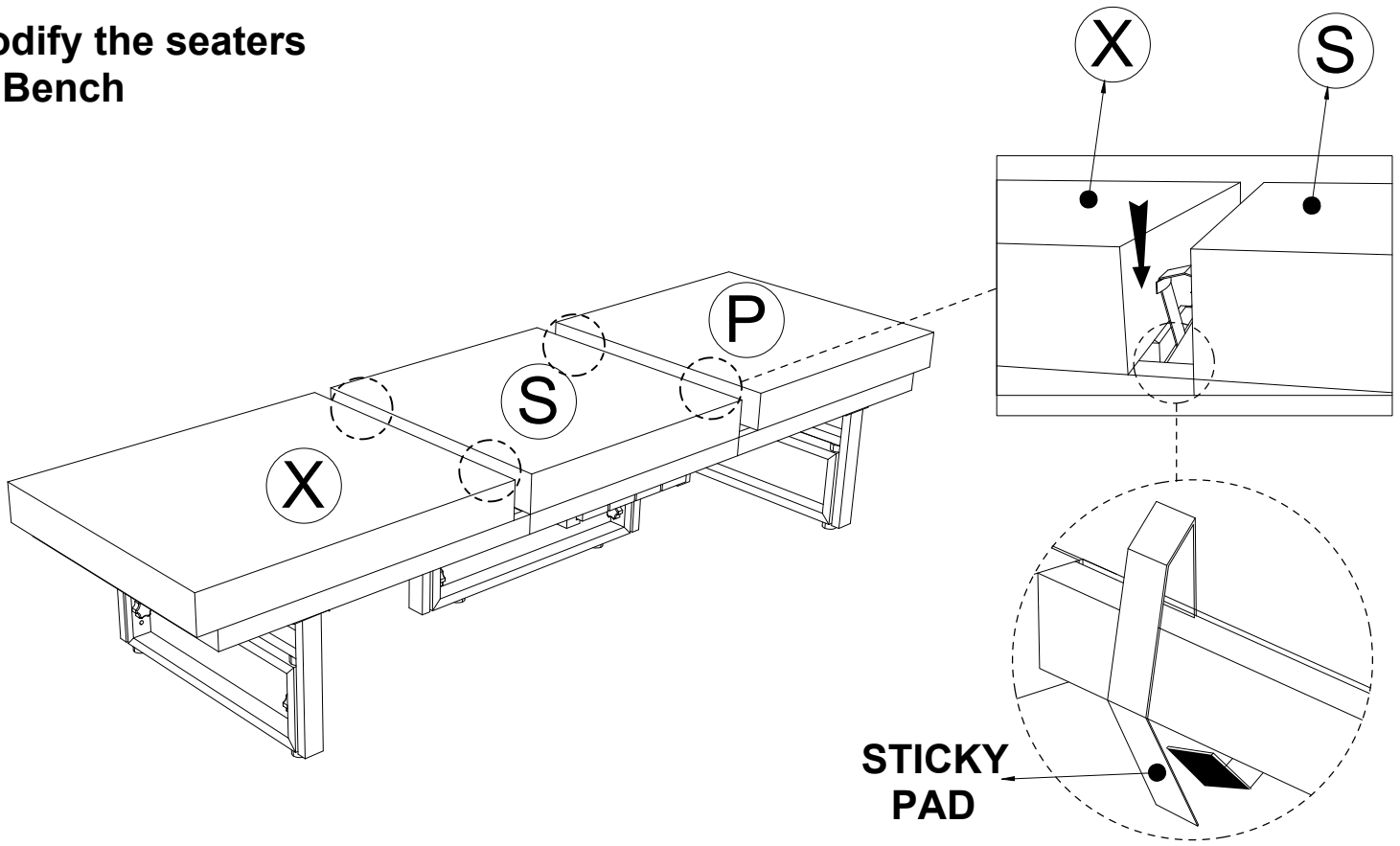

STICKY PAD

Remove the Cushions (N) & Back Benches (I)  
Connect the Cushions (X)+(S)+(P) with sticky pads.

# STEP 31

Modify the seaters of Bench

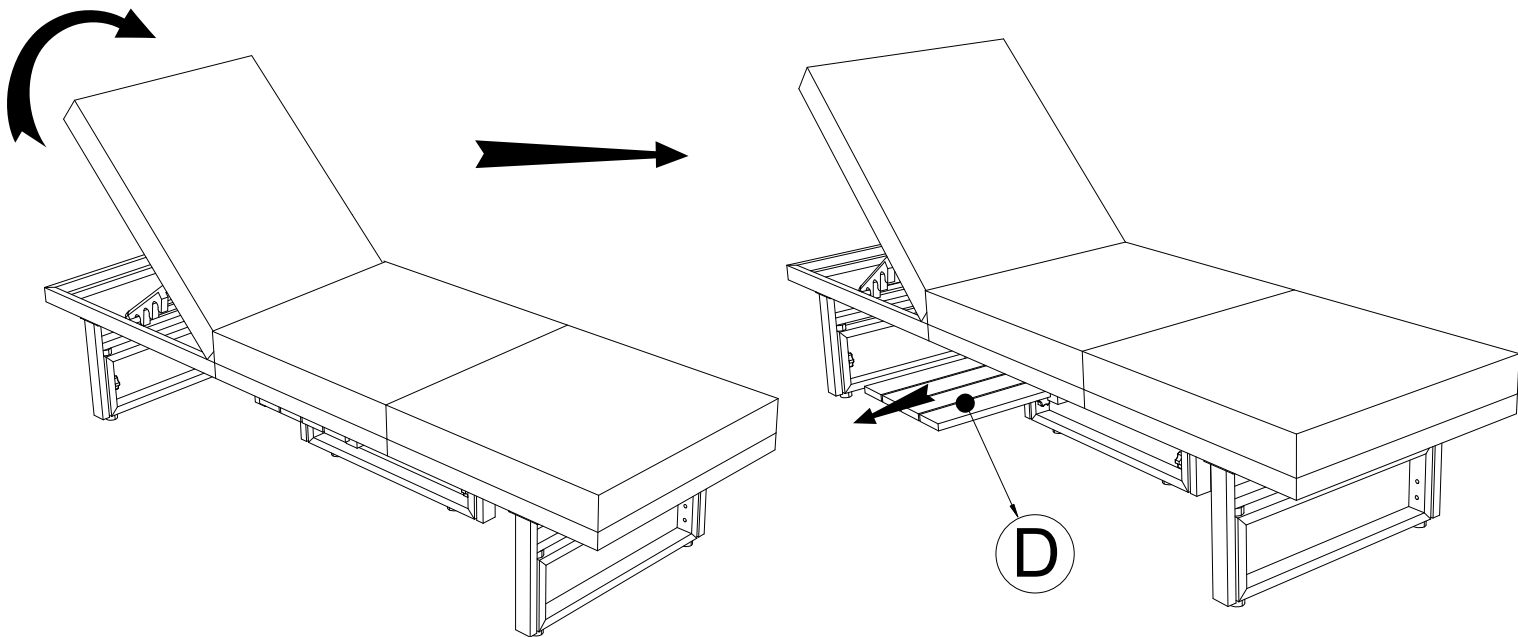

Using the lifting set of part (F) to make the Backrest for finishing bed.  
Pull the side table (D) to use for bed.

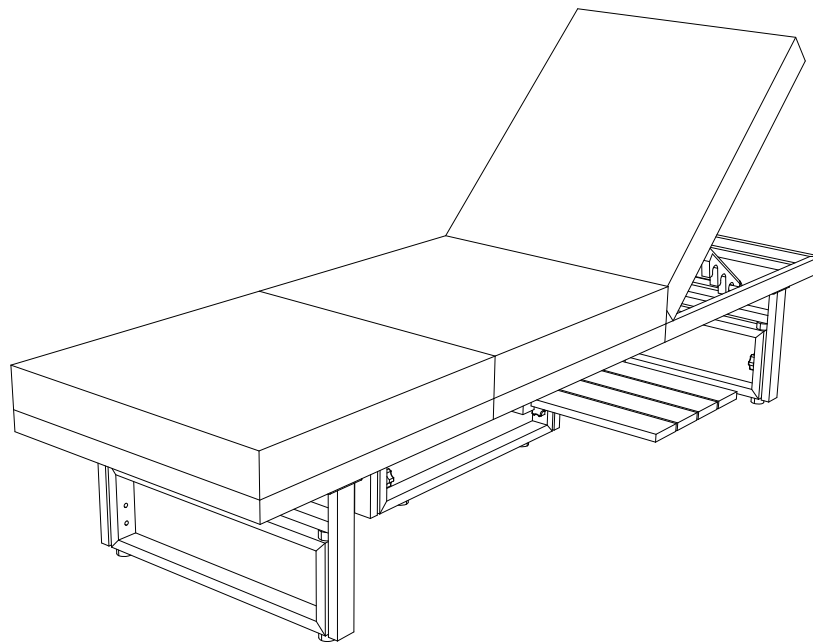
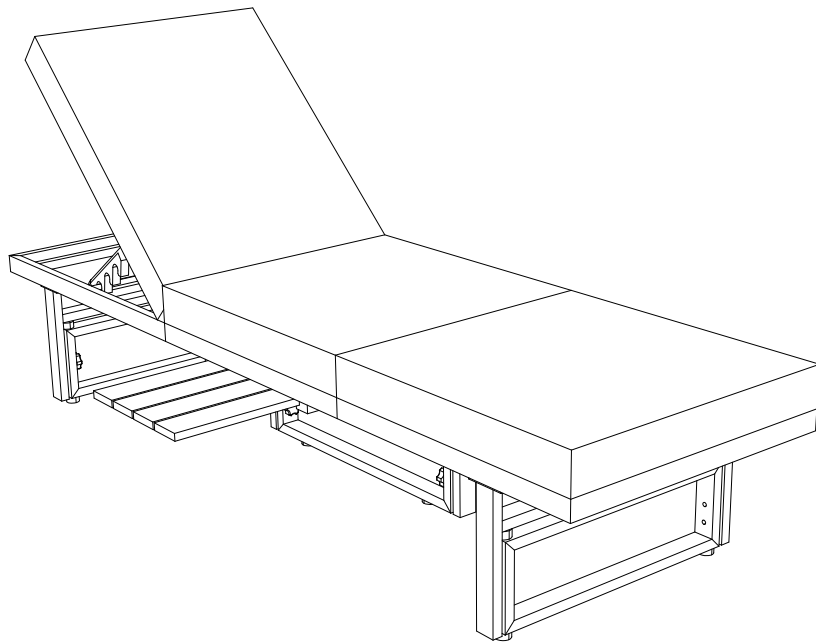

**Finish the Sharp Bed**

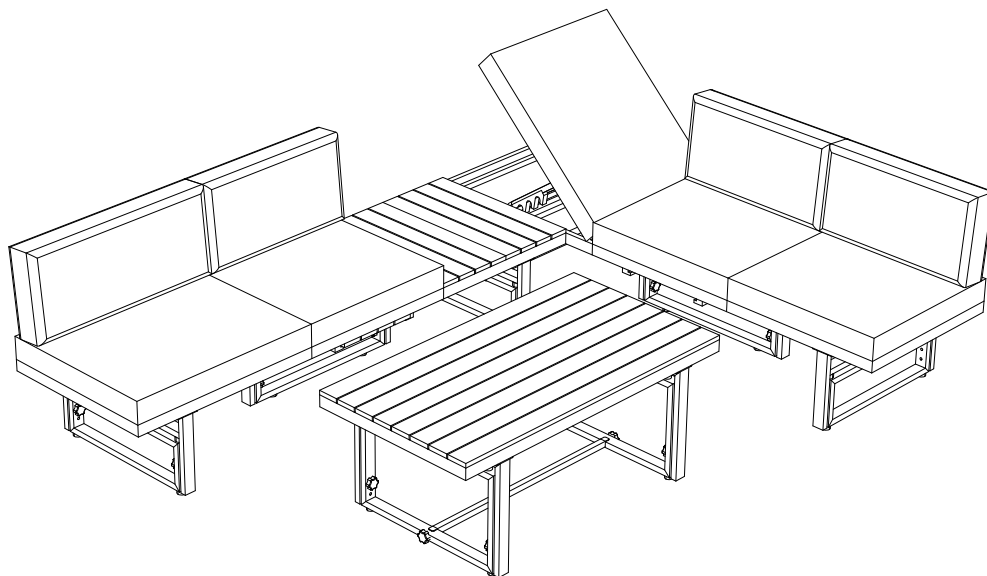
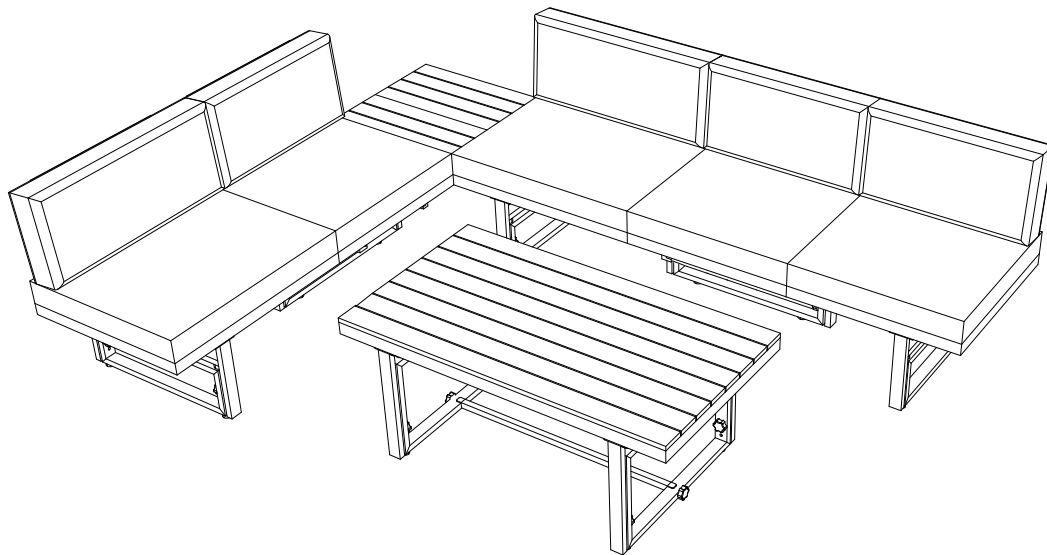
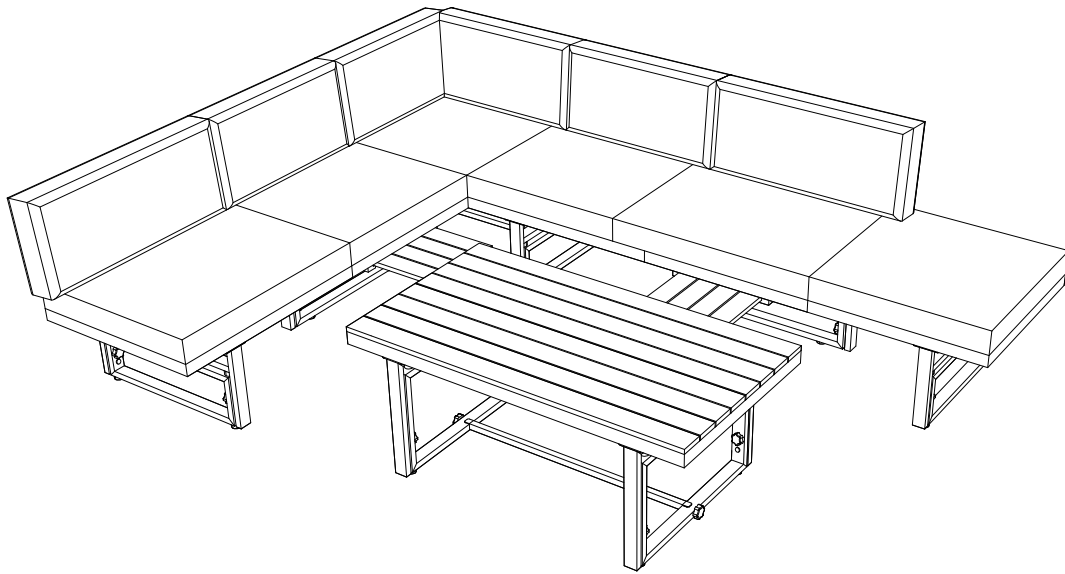

**Finish Patio Sectional Sofa Set**

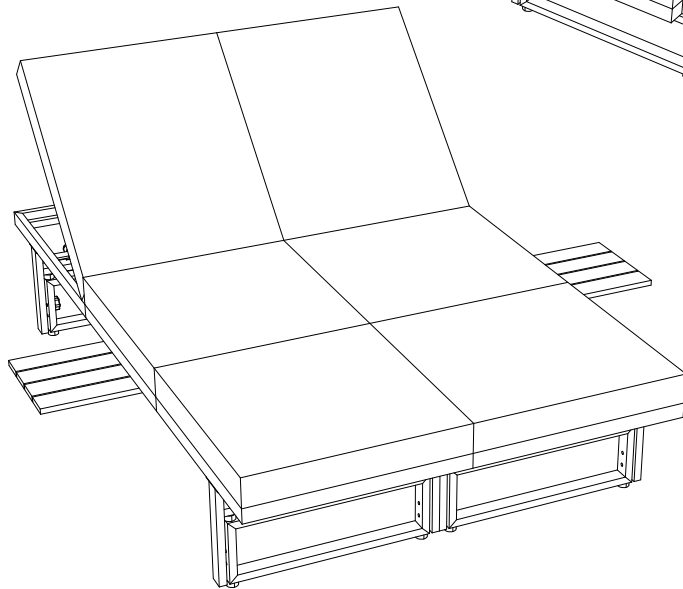
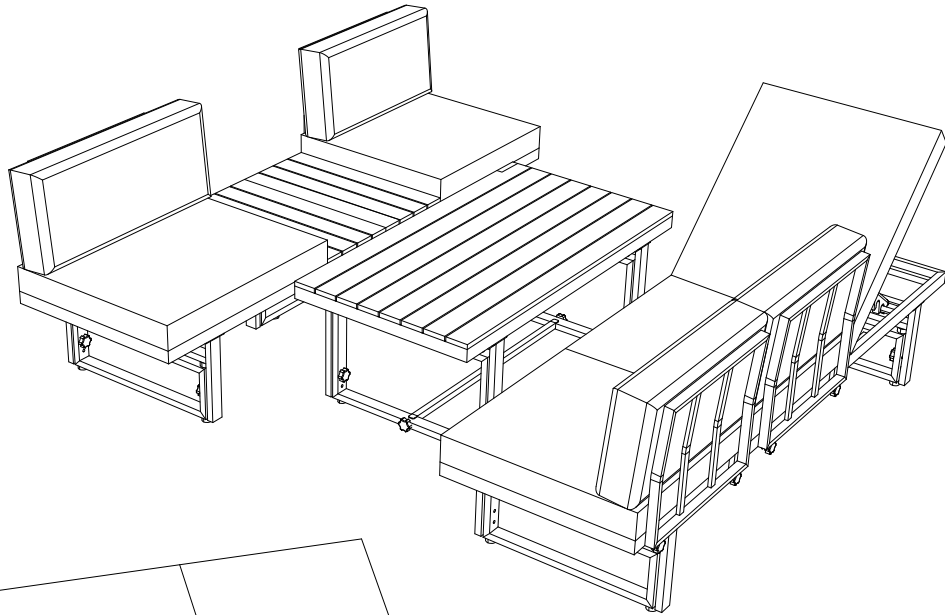
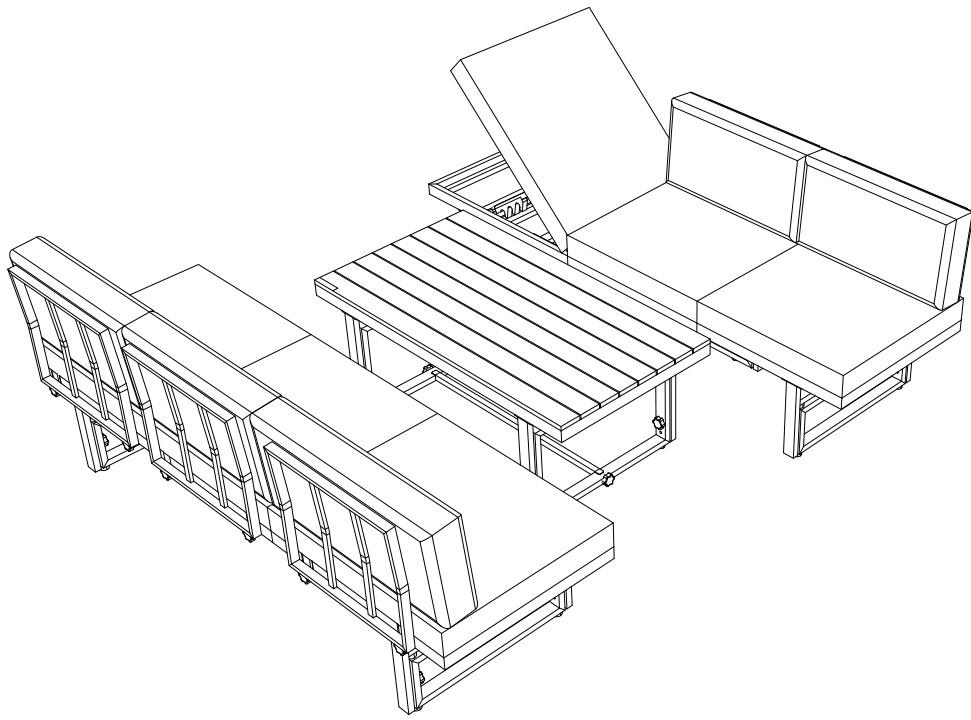

**Finish Patio Sectional Sofa Set**



# INSTALLATIONSANWEISUNG

## TERRASSEN-SOFAGARNITUREN

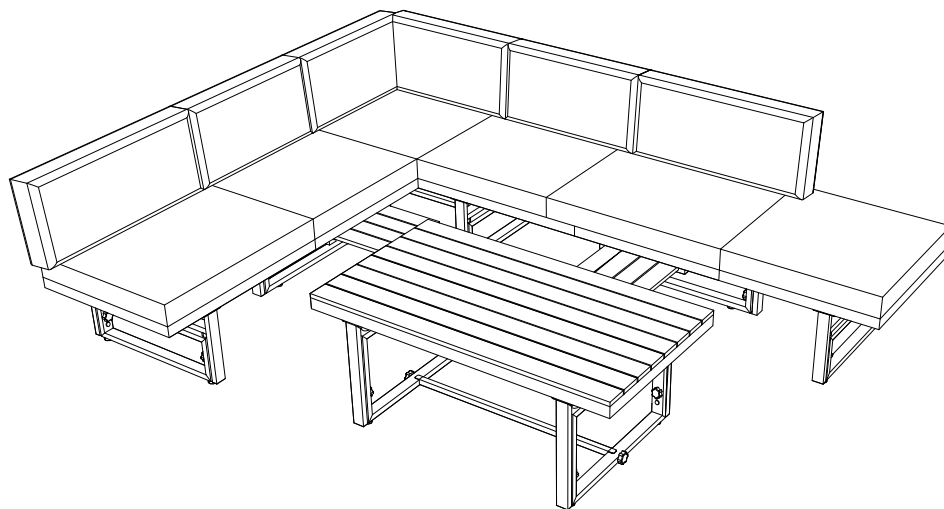

**WF318264; WF318265**

**WF318266; WF318267**

Setzen Sie vor der Installation die Schrauben in die Löcher ein und ziehen Sie sie fest, aber ziehen Sie sie nicht zu 100 % an, 70 % bis 80 % reichen aus. Schließlich, nachdem alle Schrauben installiert sind, ziehen Sie alle Schrauben zu 100 % an. Wenn Sie auf diese Probleme stoßen Wenn beispielsweise die Löcher nicht ausgerichtet werden können oder einige Teile nicht installiert werden können, überprüfen Sie bitte, ob die Schrauben richtig verwendet werden, und passen Sie den festen Sitz der Schrauben an.

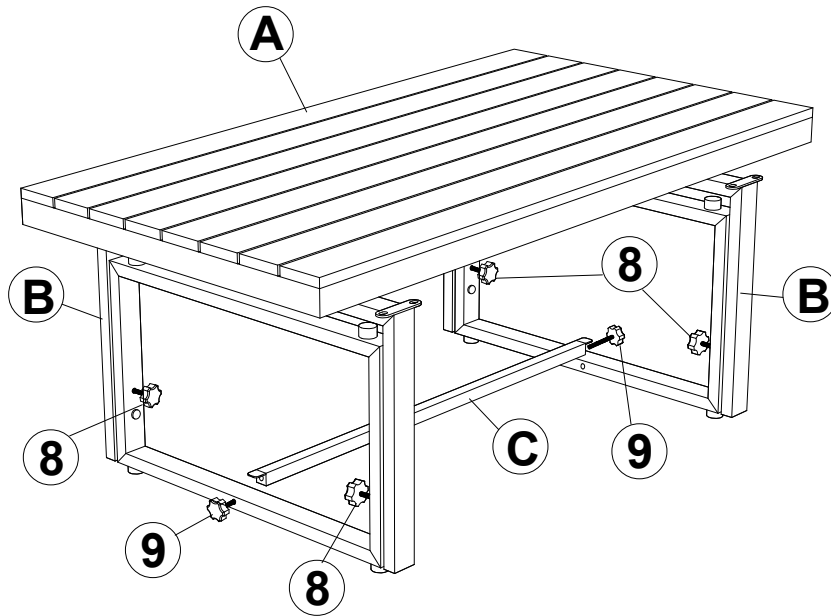

**x1**

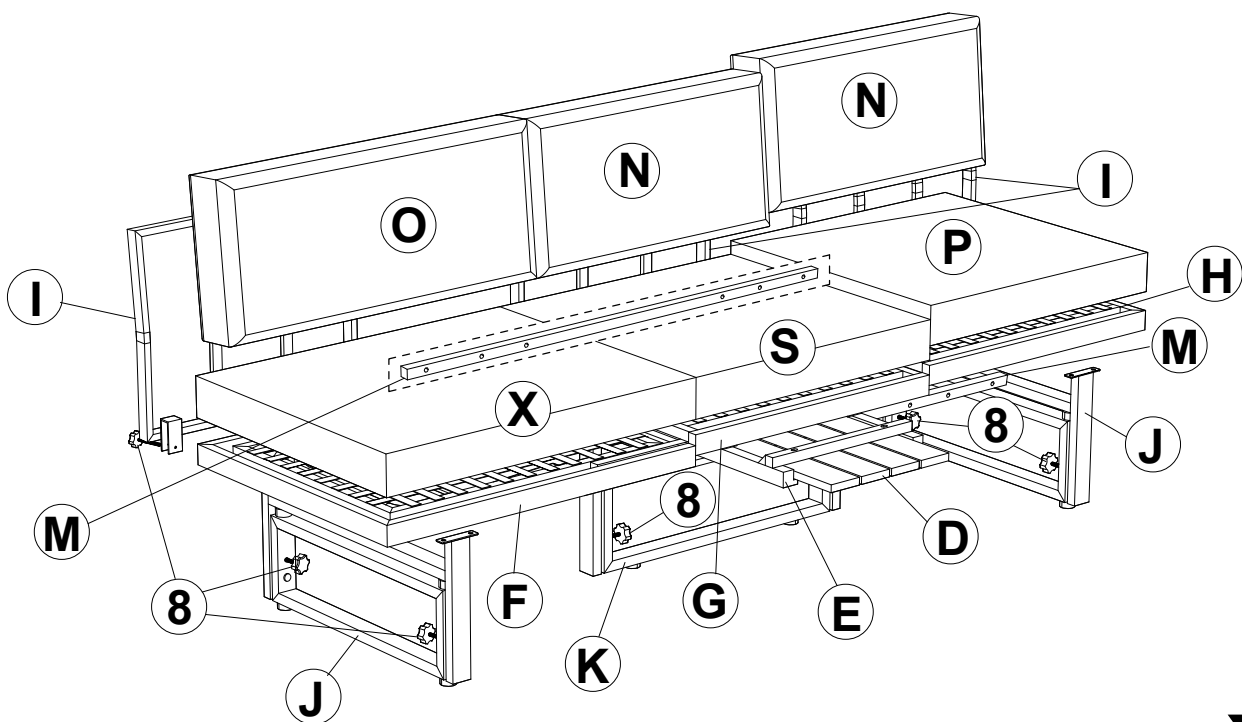

**x2**

**Beachten:**

1. 50 % festziehen, bevor alle Schrauben befestigt werden. Anstelle einer elektrischen Bohrmaschine wird ein Inbusschlüssel empfohlen.
2. Stellen Sie den Gegenstand zum Ausrichten auf einen ebenen Untergrund und stellen Sie sicher, dass er stabil bleibt
3. Alle Schrauben mit Werkzeug nach und nach festziehen.
4. Wenn die Schrauben bei der Montage nicht mit den Löchern übereinstimmen, lösen Sie bitte alle Drehen Sie die anderen Schrauben auf 50 % und setzen Sie den Montagevorgang fort.
5. Sollte der Artikel nicht stabil stehen, lösen Sie bitte alle Schrauben, stellen Sie ihn auf einen ebenen Untergrund und ziehen Sie alle Schrauben wieder fest.
6. Hinweis: Wenn eine oder mehrere Schrauben während der Montage vollständig angezogen werden, besteht die Möglichkeit, dass die anderen nicht mit den Löchern ausgerichtet sind. Darüber hinaus sind alle Löcher relativ größer ausgelegt, um mehr Platz für die Justierung der Schrauben zu bieten.

# Teileliste:

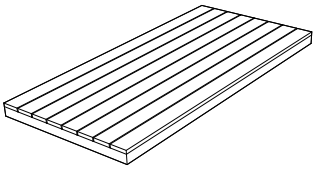
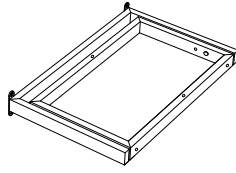
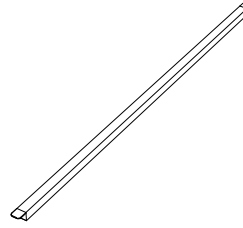
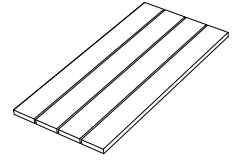
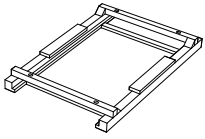
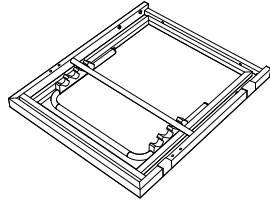
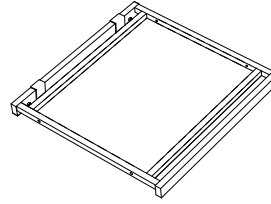
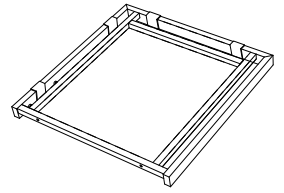
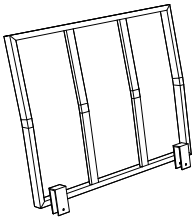
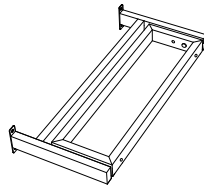
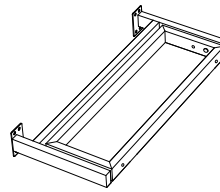
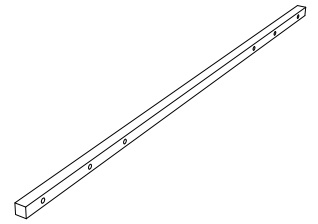
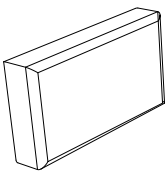
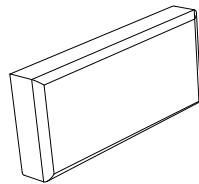
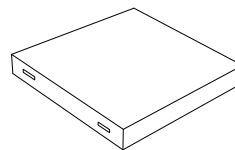
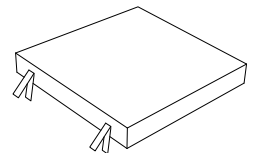
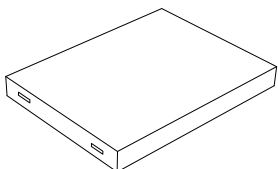
**A****Oberer Tisch (1 pc)****B****Beintisch (2 pcs)****C****Unterstützende Bar (1 pc)****D****Beistelltisch (2 pcs)****E****Holztablett (2 pcs)****F****Sitzbank 1 (2 pcs)****G****Sitzbank 2 (2 pcs)****H****Sitzbank 3 (2 pcs)****I****Rückbank (6 pcs)****J****Beinbank (4 pcs)****K****Stützbein (2 pcs)****M****Verbindungsstange (4 pcs)****N****Rückenkissen 1 (4 pcs)****O****Rückenkissen 2 (2 pcs)****P****Sitzkissen 1 (2 pcs)****S****Sitzkissen 2 (2 pcs)****X****Sitzkissen 3 (2 pcs)**

# Hardware:

1

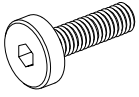

Extra (3 pcs)  
Bolzen M6x15 (40 pcs)

2

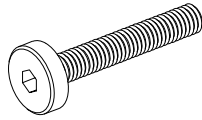

Extra (3 pcs)  
Bolzen M6x35 (32 pcs)

3

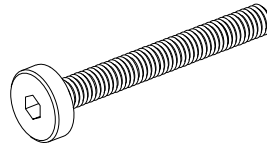

Extra (1 pc)  
Bolzen M6x55 (8 pcs)

4

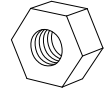

Extra (1 pc)  
Eru M6 (8pcs)

5

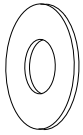

Extra (3 pcs)  
Flache  
Unterlegscheibe M6 (88 pcs)

6

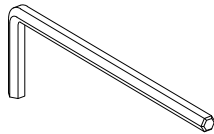

Inbusschlüssel (2 pcs)

7

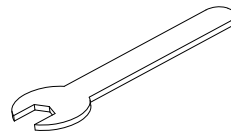

Schlüssel (1 pc)

8

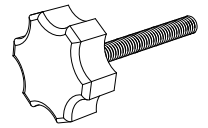

Extra (2 pcs)  
Fester Bolzen 1 (28 pcs)

9

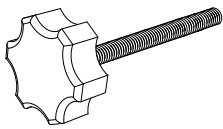

Fester Bolzen 2 (2 pcs)

10

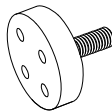

Extra (2 pcs)  
Verstellbares,  
waagrechtes Bein(32 pcs)

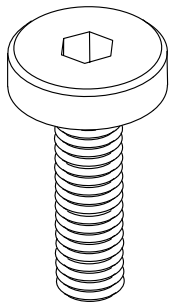

**BOLZEN**  
M6x15 MM

1

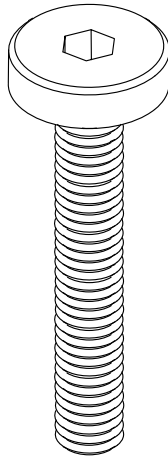

**BOLZEN**  
M6x35 MM

2

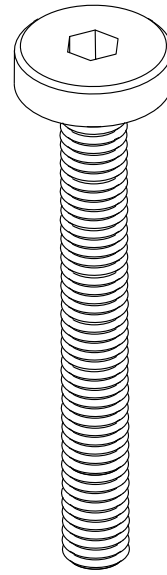

**BOLZEN**  
M6x55 MM

3

Bitte beachten Sie, dass die Formen der Schrauben 1 und 2 und 3  
ähnlich sind.

Bitte gemäß den Anweisungen installieren und unterscheiden!

# KARTONINHALT:

## WF318264

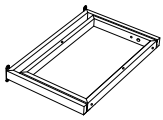

**B** x2

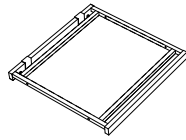

**G** x1

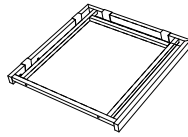

**H** x1

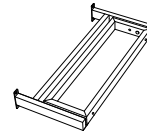

**J** x1

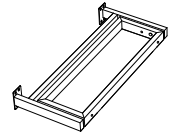

**K** x1

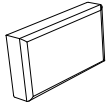

**N** x2

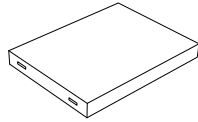

**X** x2

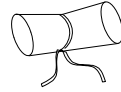

Hardware

## WF318265

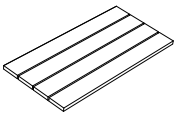

**D** x2

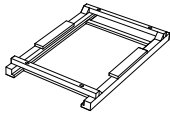

**E** x2

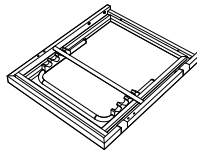

**F** x2

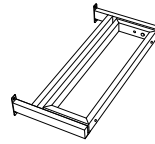

**J** x2

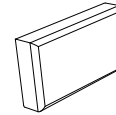

**N** x1

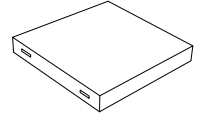

**P** x2

## WF318266

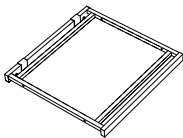

**G** x1

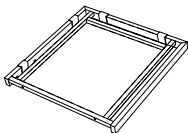

**H** x1

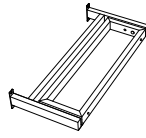

**J** x1

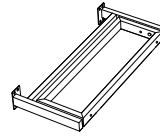

**K** x1

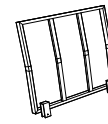

**I** x6

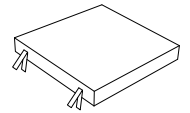

**S** x2

## WF318267

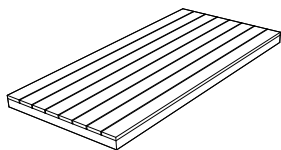

**A** x1

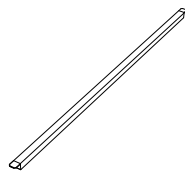

**C** x1

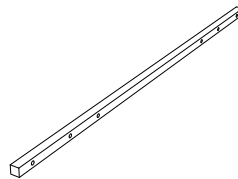

**M** x4

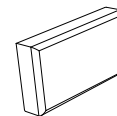

**N** x1

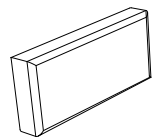

**O** x2

# SCHRITT 1

**B** x1

**10** x4

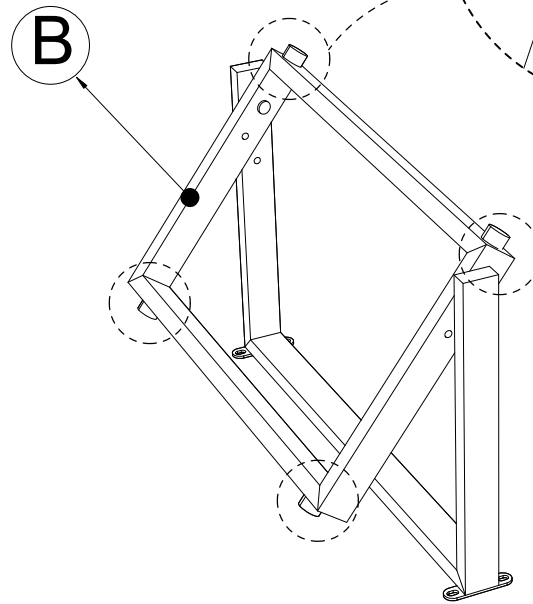

**x2**

Befestigen Sie das verstellbare Nivellierbein (10) und den Beintisch (B) und ziehen Sie die Details mit der Hand fest

# SCHRITT 2

**A** x1

**1** x8

**5** x8

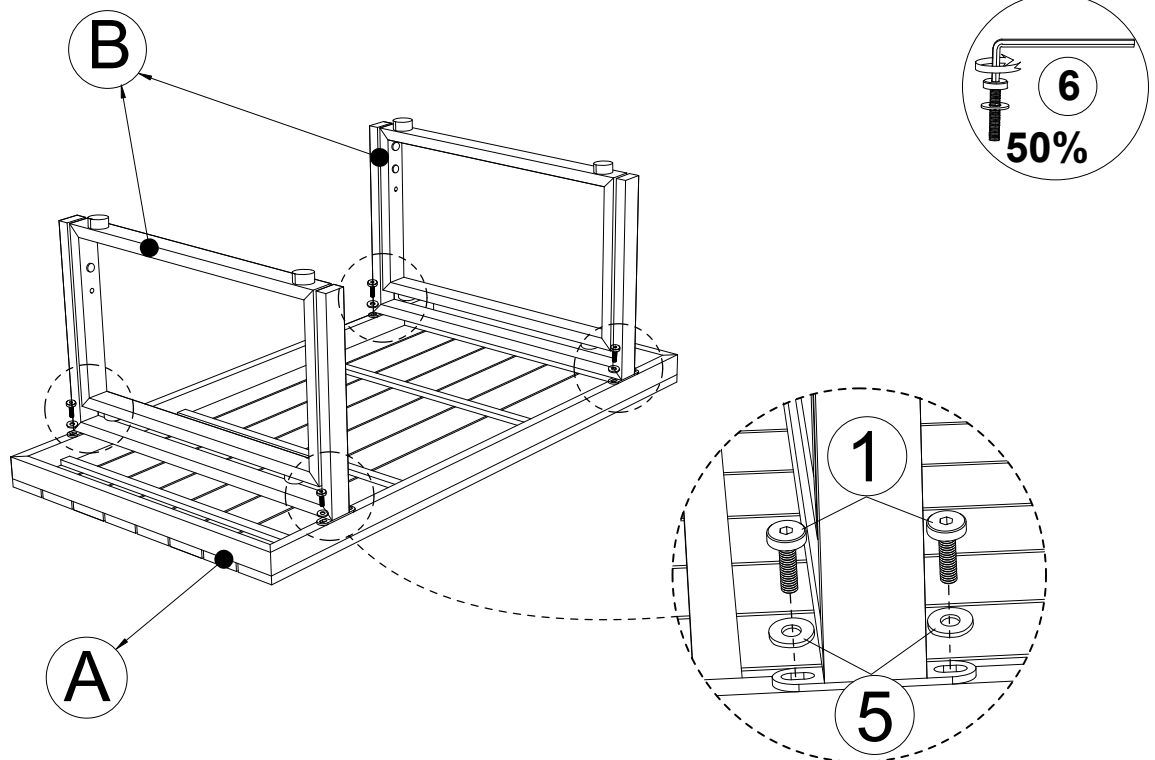

Verbinden Sie das Teil aus Schritt 1 und den oberen Tisch, ziehen Sie die Schraube (1) und die Unterlegscheibe (5) fest. mit Inbusschlüssel (6).

# SCHRITT 3

Ⓒ x1

9 x2

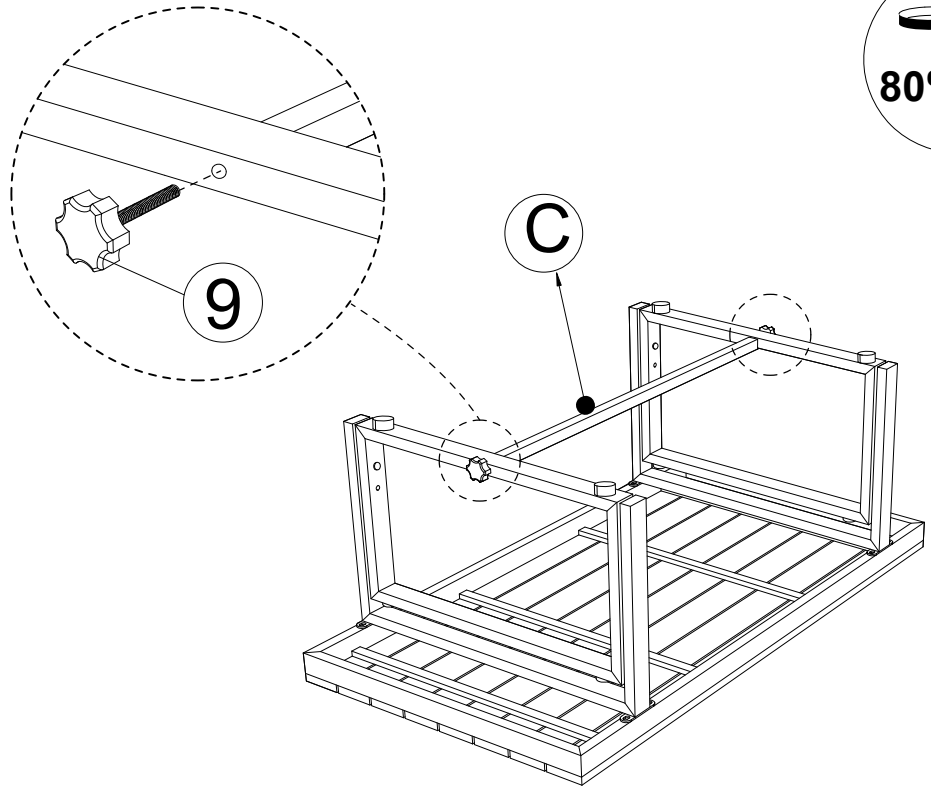

80%

Verbinden Sie das Teil aus Schritt 2 und die Stützstange (C).  
Ziehen Sie die feste Schraube (9) mit der Hand fest

# SCHRITT 4

8 x4

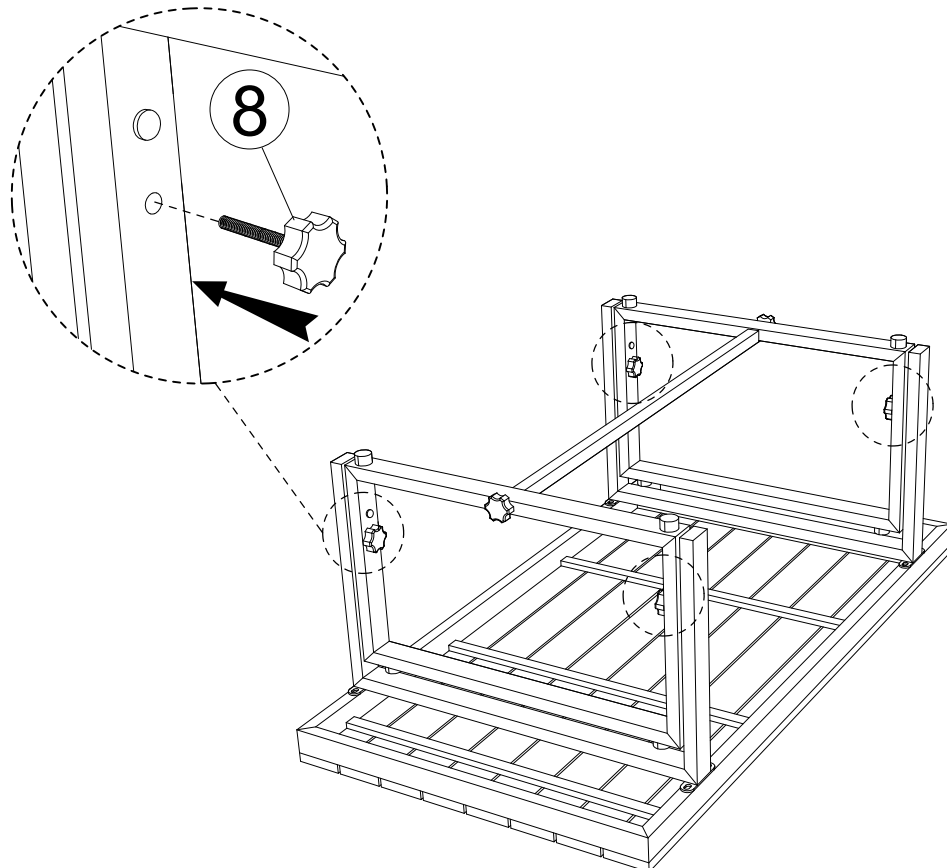

80%

Halten Sie die ursprüngliche Spitze des Beins (B) fest und ziehen Sie die feste Schraube (8) mit der Hand fest



# SCHRITT 5

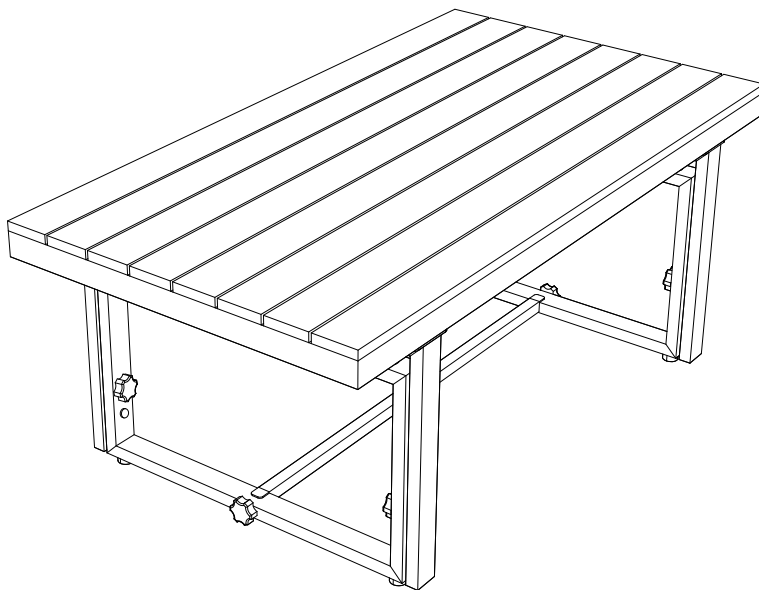
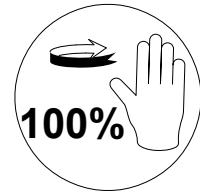
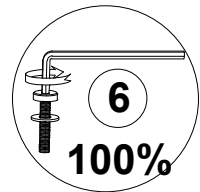

**Stellen Sie den Tisch aufrecht und ziehen Sie die Schrauben mit dem Inbusschlüssel (5) und der Hand fest an**

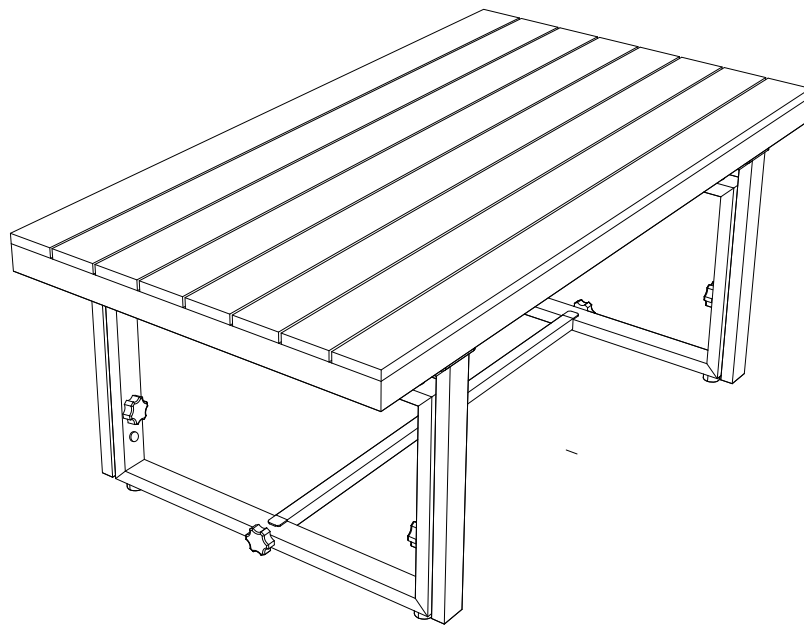

**Beenden Sie den Tisch**

## SCHRITT 6A

Ändern Sie die Höhe  
des Beintisches

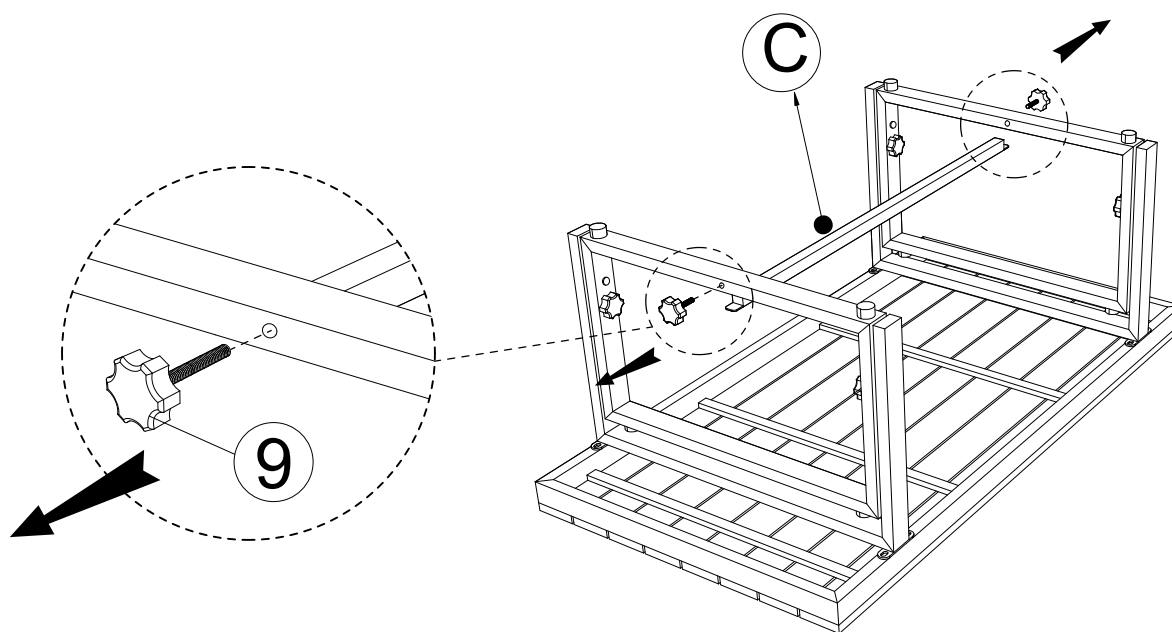
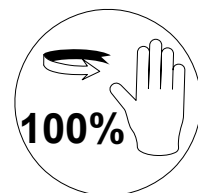

Drehen Sie den Tisch aus Schritt 5 um und entfernen Sie die Stützstange (C).  
Lösen und entfernen Sie die feste Schraube (9).

## SCHRITT 6B

Ändern Sie die Höhe  
des Beintisches

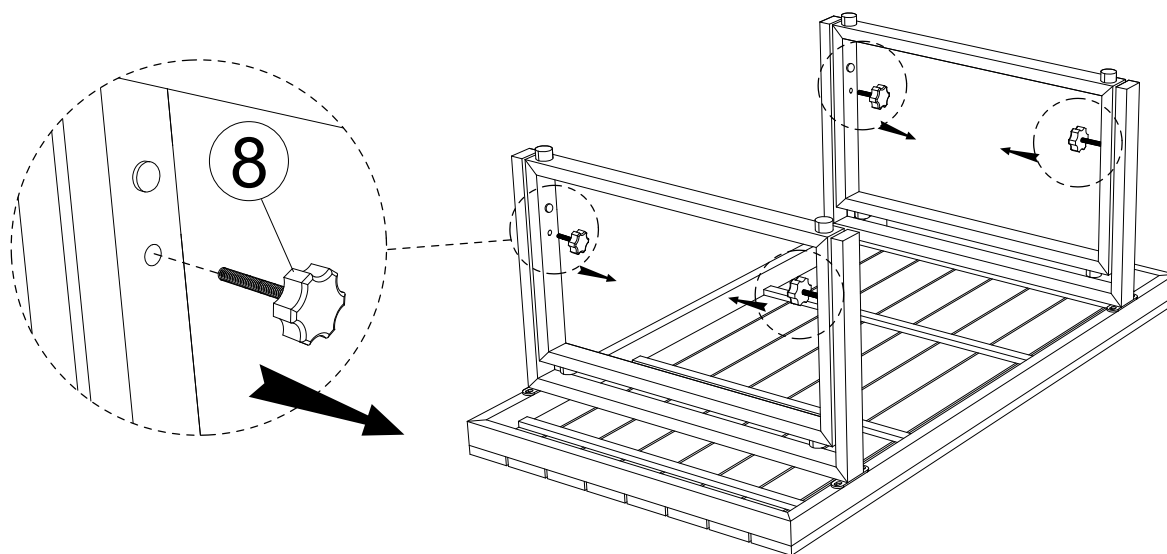
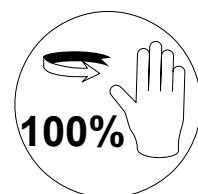

Lösen und entfernen Sie die feste Schraube (8).

## SCHRITT 6C

Ändern Sie die Höhe  
des Beintisches

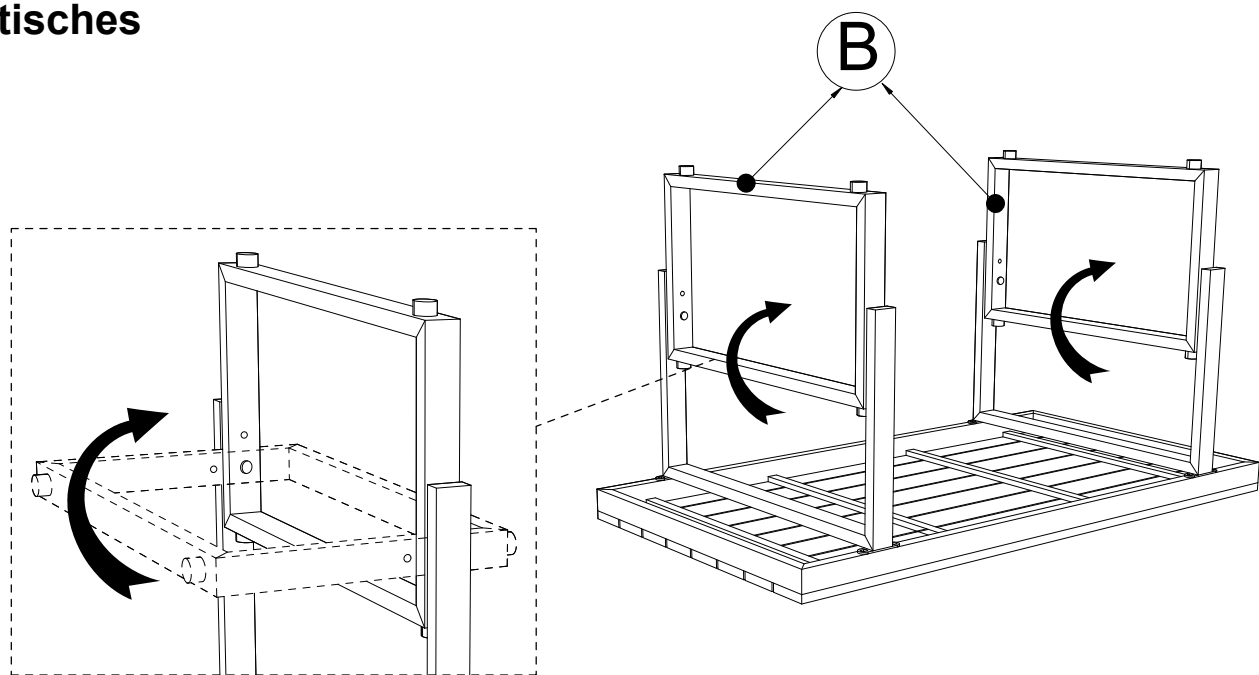

Drehen Sie den inneren Teil von (B) im Winkel von 180° nach außen

## SCHRITT 6D

Ändern Sie die Höhe  
des Beintisches

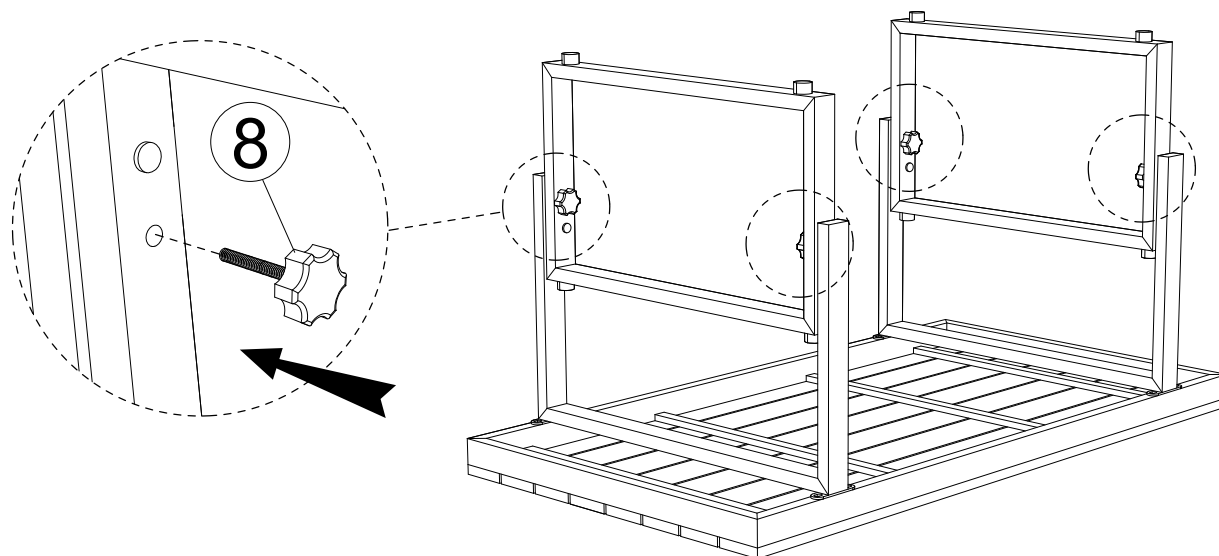
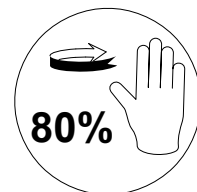

Festen Bolzen (8) handfest anziehen

## SCHRITT 6E

Ändern Sie die Höhe  
des Beintisches

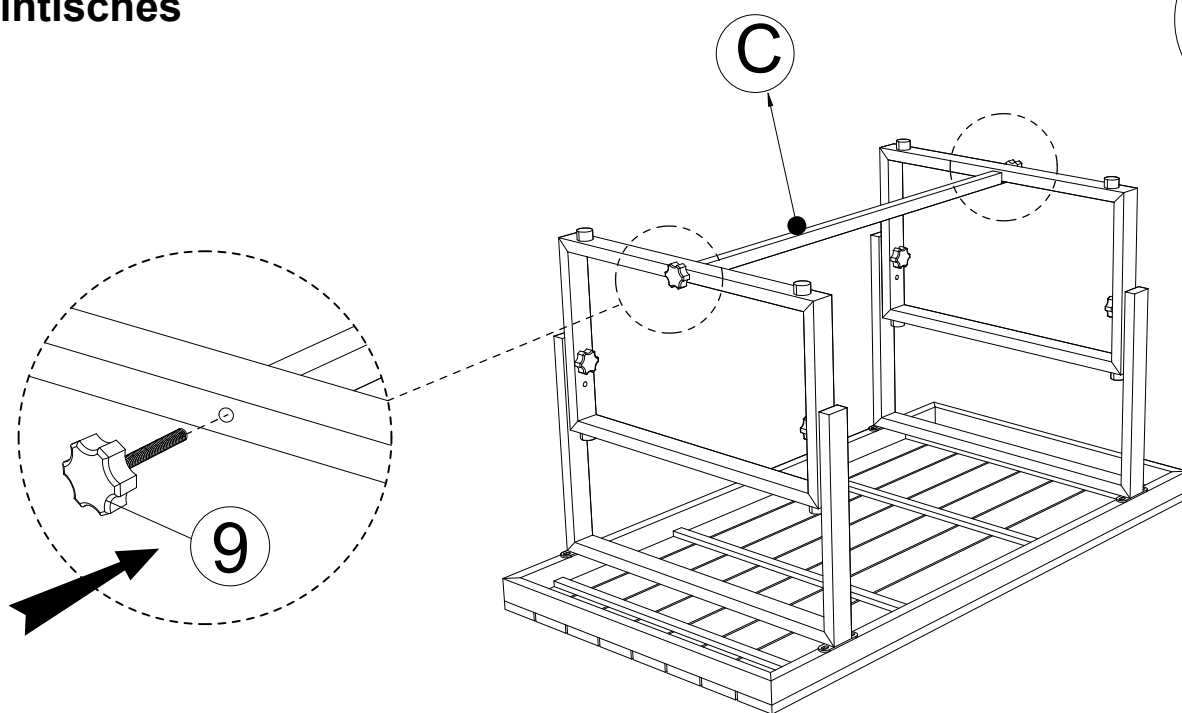
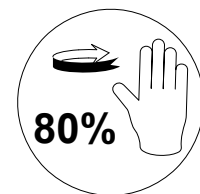

Verbinden Sie die Stützstange (C) erneut. Ziehen Sie die feste Schraube (9)  
mit der Hand fest

## SCHRITT 6F

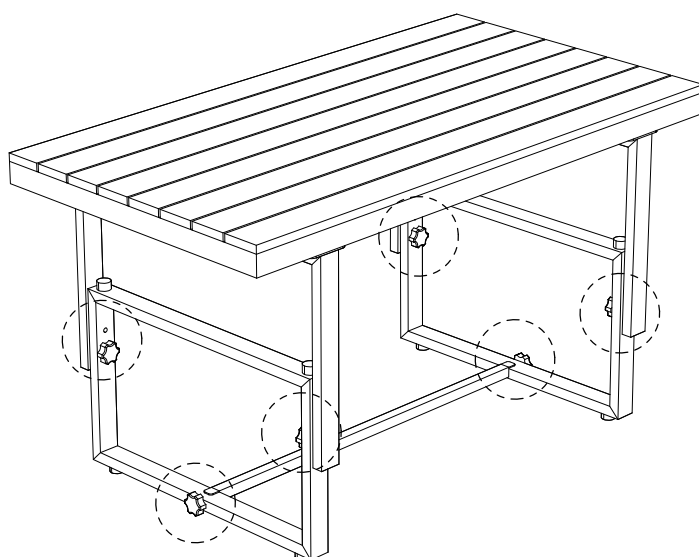
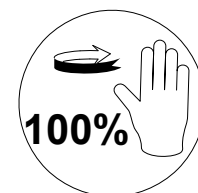

Ziehen Sie alle festen Schrauben mit der Hand fest an.

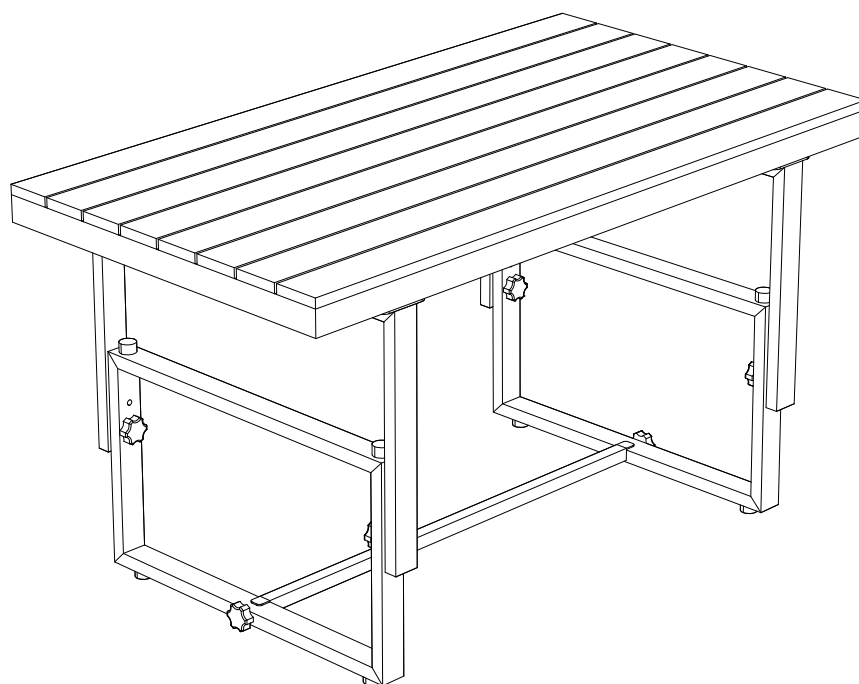

**Beende den höheren Tisch**

# SCHRITT 7

Ⓒ x1

Ⓕ x1

③ x2

⑤ x2

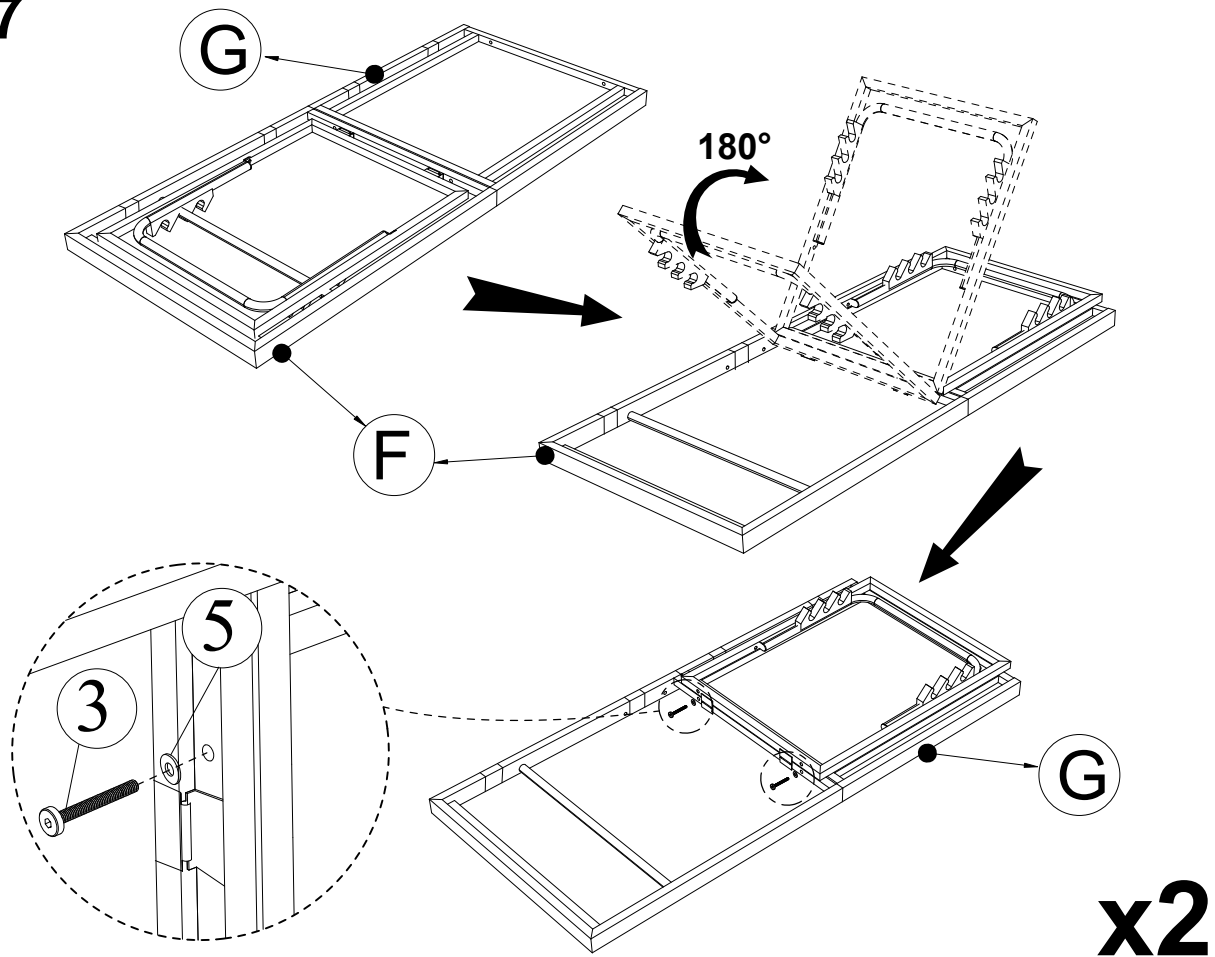

Platzieren Sie Sitzbank 1 (F) neben Sitzbank 2 (G). Drehen Sie die inneren Teile von (F) mit 180°. Schieben Sie die Schrauben (3) und die Unterlegscheibe (5) in die Löcher.

# SCHRITT 8

④ x2

⑤ x2

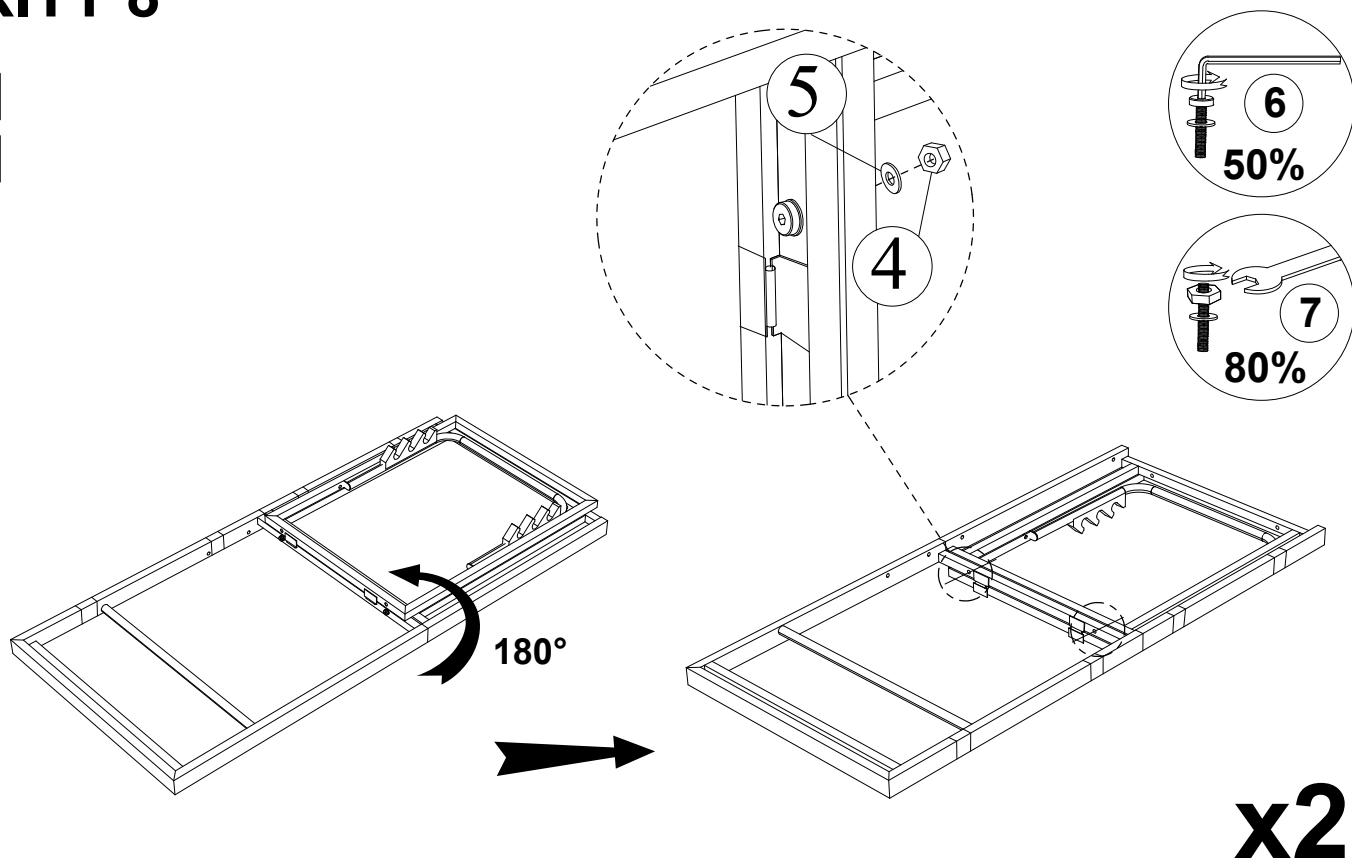

Drehen Sie das Teil aus Schritt 7 um 180° nach unten und ziehen Sie die Schraube (3) fest. & Unterlegscheibe (5) & Eru (4) mit Inbusschlüssel (6), Schlüssel (7).

## STEP 9

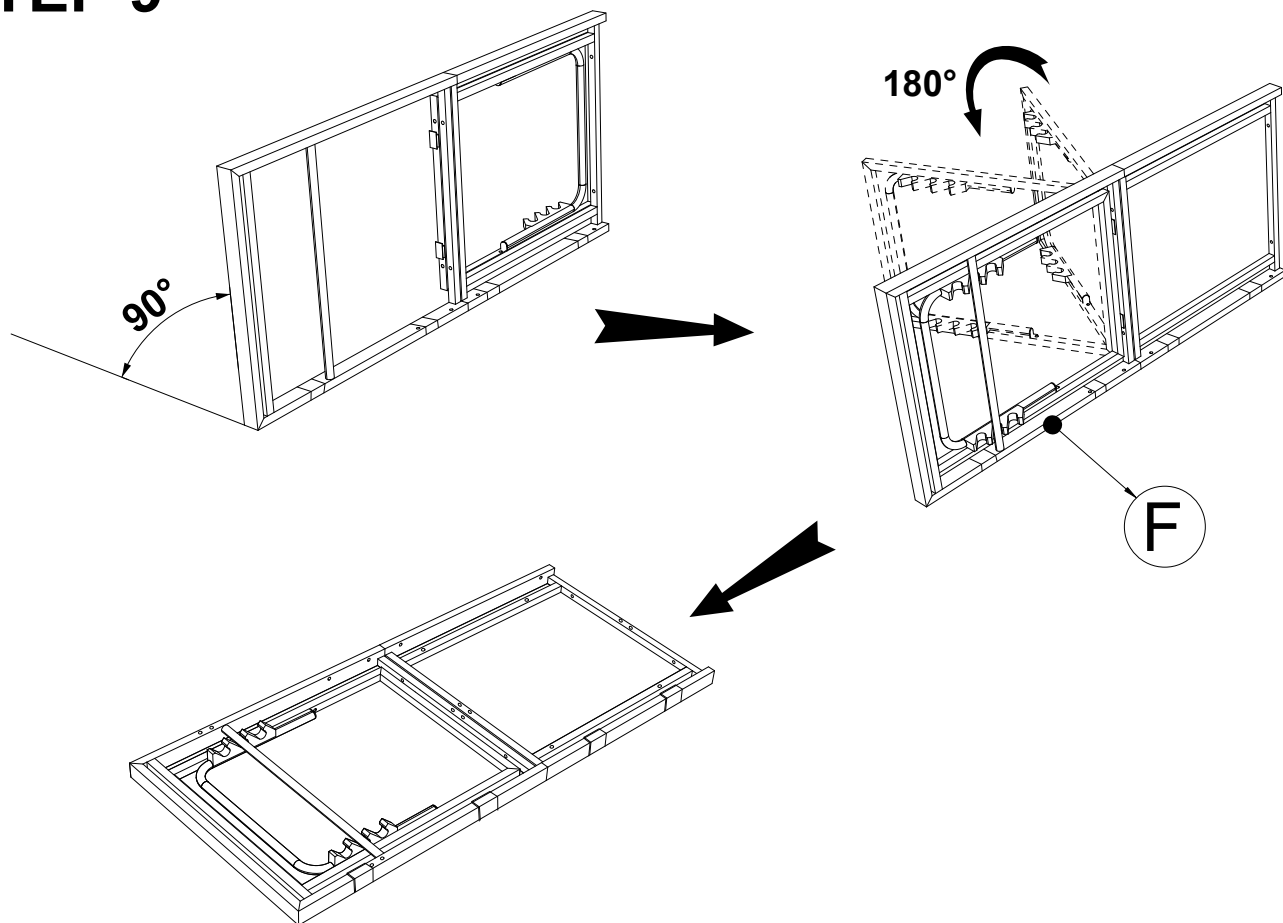

Drehen Sie das Teil aus Schritt 8 im Winkel von 90° und drehen Sie den inneren Teil von (F) um 180° zurück in die ursprüngliche Position. Legen Sie alle Teile ab

## STEP 10

(H) x1

(3) x2

(4) x2

(5) x4

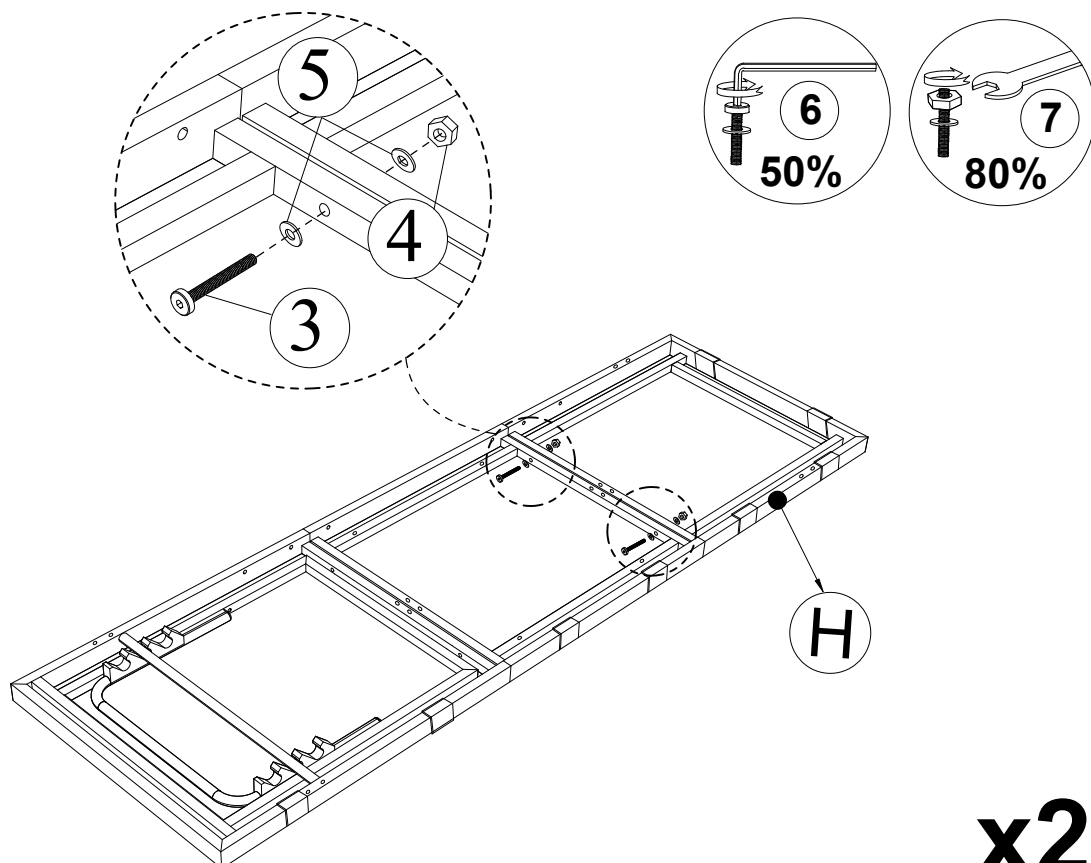

Verbinden Sie das Teil aus Schritt 9 und Sitzbank 3 (H) und ziehen Sie die Schraube (4) fest. & Unterlegscheibe (5) & Eru (4) mit Inbusschlüssel (6) und Schlüssel (7).



# SCHRITT 11

(M) x2

(2) x12

(5) x12

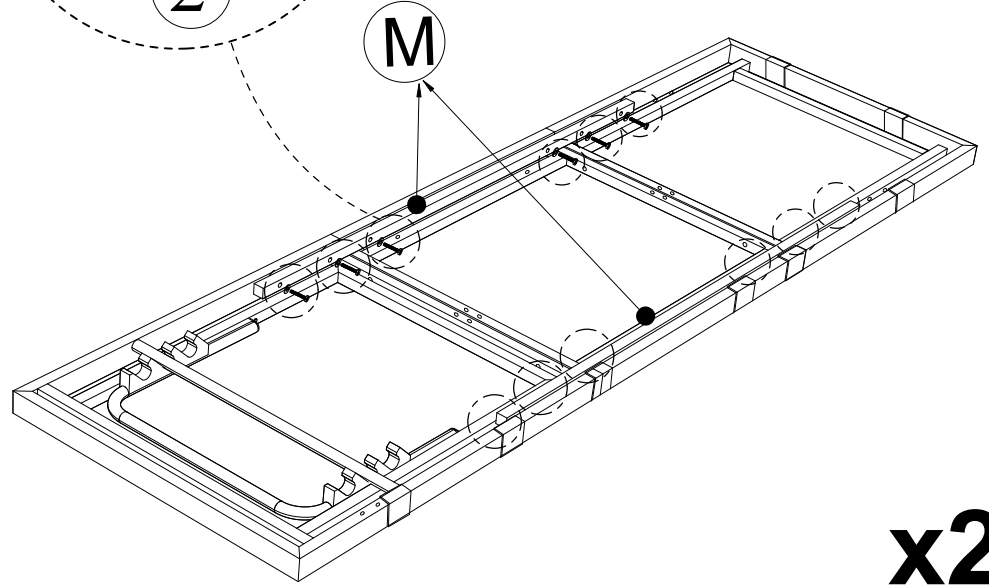
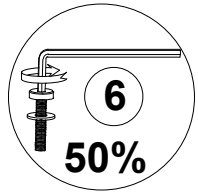
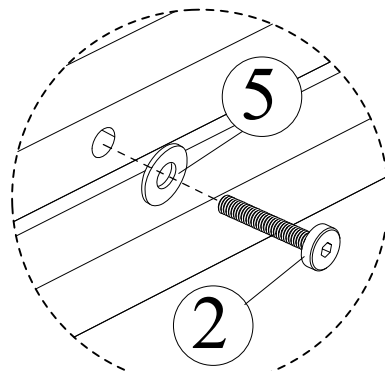

Verbinden Sie das Teil aus Schritt 10 mit der Verbindungsstange (M) und ziehen Sie die Schraube (2) fest. & Unterlegscheibe (5) mit Inbusschlüssel (6).

# SCHRITT 12

(E) x1

(2) x4

(5) x4

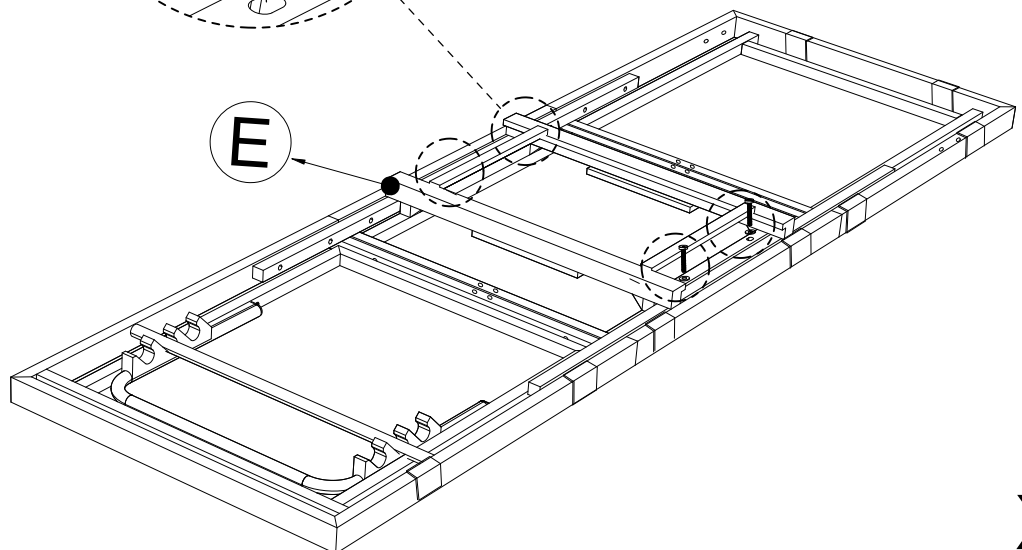
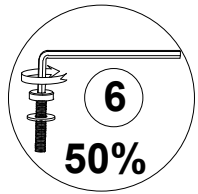
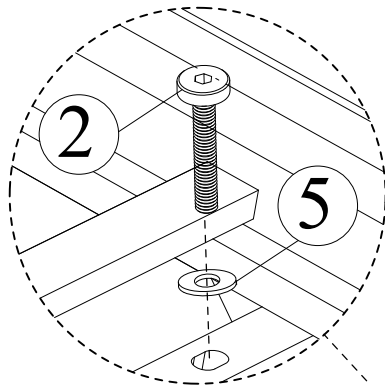

Verbinden Sie das Teil aus Schritt 11 und das Holztablett (E) und ziehen Sie die Schraube (2) fest. & Unterlegscheibe (5) mit Inbusschlüssel (6).

# SCHRITT 13

**J** x1

**K** x1

**10** x8

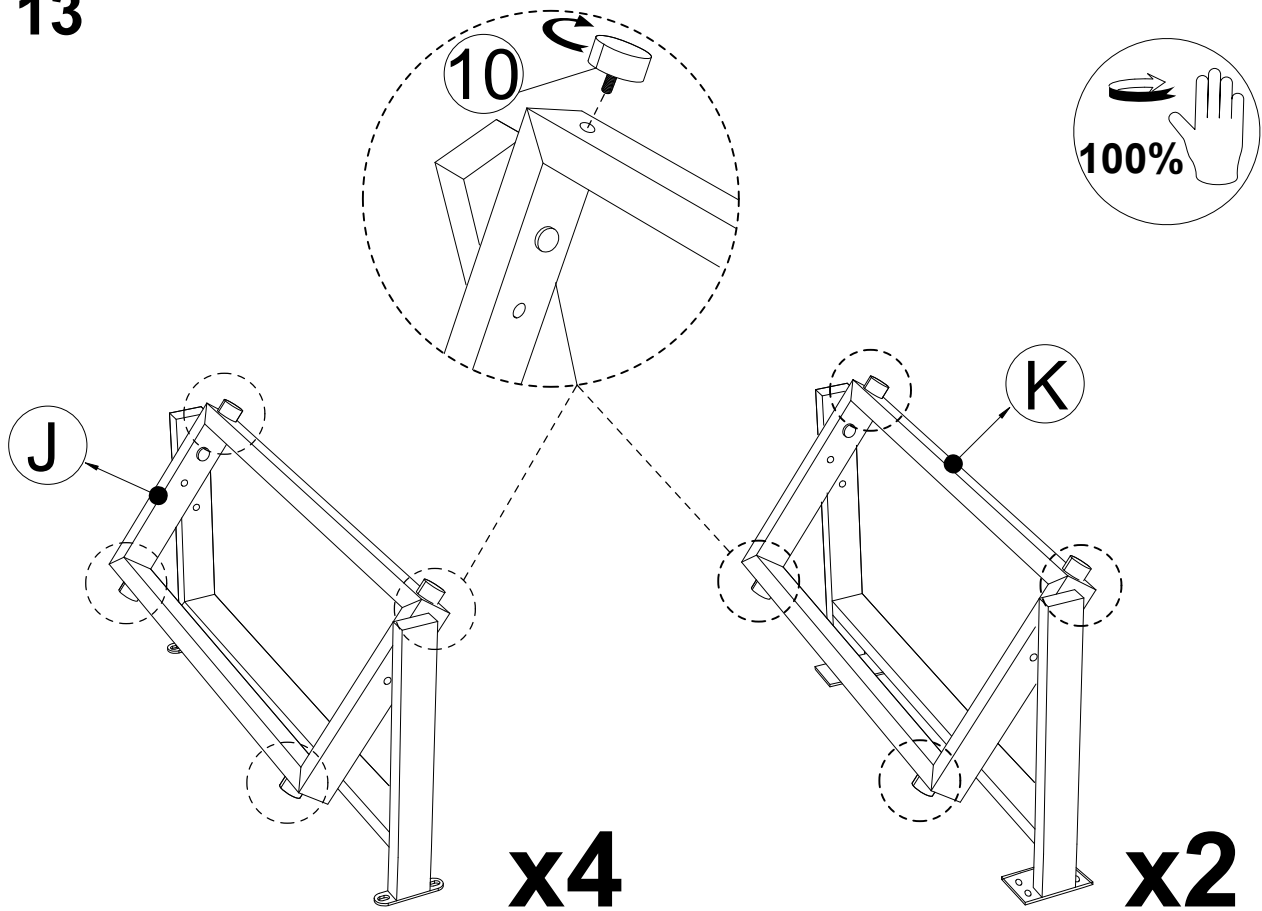

Befestigen Sie das verstellbare Nivellierbein (10), die Beinbank (J) und das Stützbein (K). Ziehen Sie die Details mit der Hand fest.

# SCHRITT 14

**1** x8

**5** x8

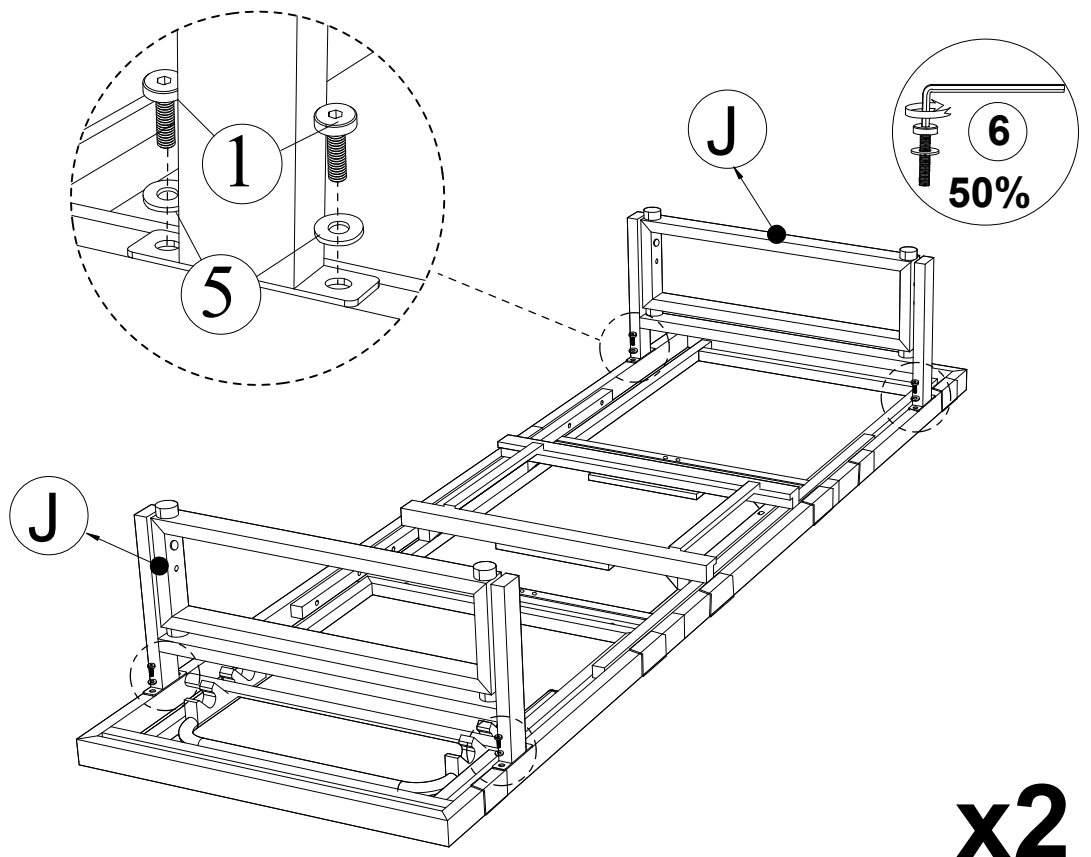

Verbinden Sie das Teil aus Schritt 12 und die Beine der Bank (J) aus Schritt 13, ziehen Sie die Schraube (1) und die Unterlegscheibe (5) mit einem Inbusschlüssel (6) fest.

# SCHRITT 15

① x8

⑤ x8

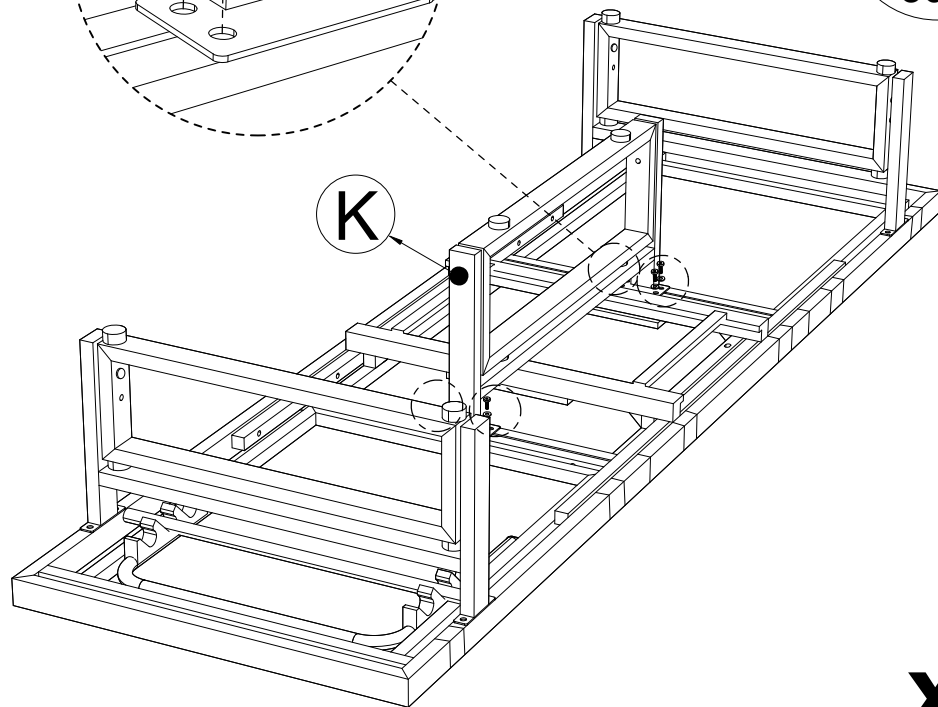
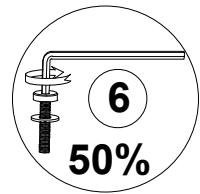
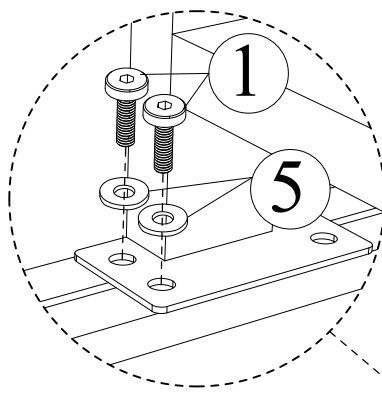

x2

Verbinden Sie das Teil aus Schritt 14 und das Stützbein (K) aus Schritt 13, ziehen Sie die Schraube (1) und die Unterlegscheibe (5) mit dem Inbusschlüssel (6) fest.

# SCHRITT 16

⑧ x6

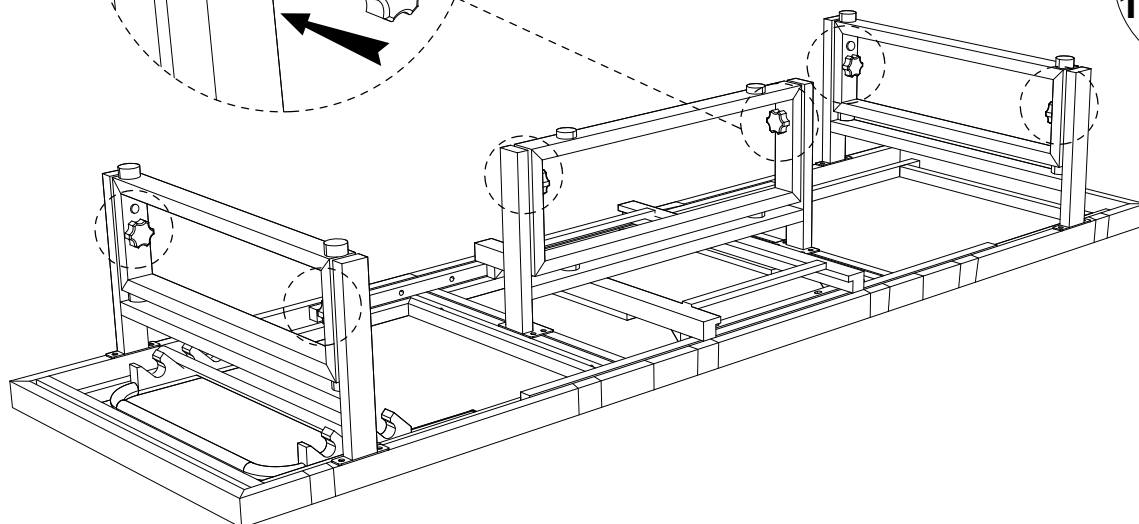
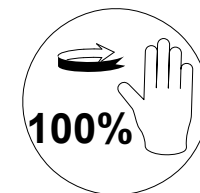
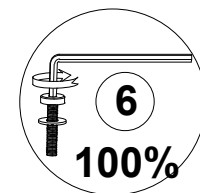
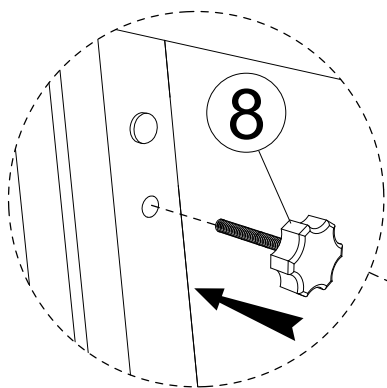

x2

Halten Sie die Originalspitze aller Beine fest und ziehen Sie die feste Schraube (8) mit der Hand fest. Ziehen Sie die Schrauben mit dem Inbusschlüssel (5) und der Hand fest an

# SCHRITT 17

① x6

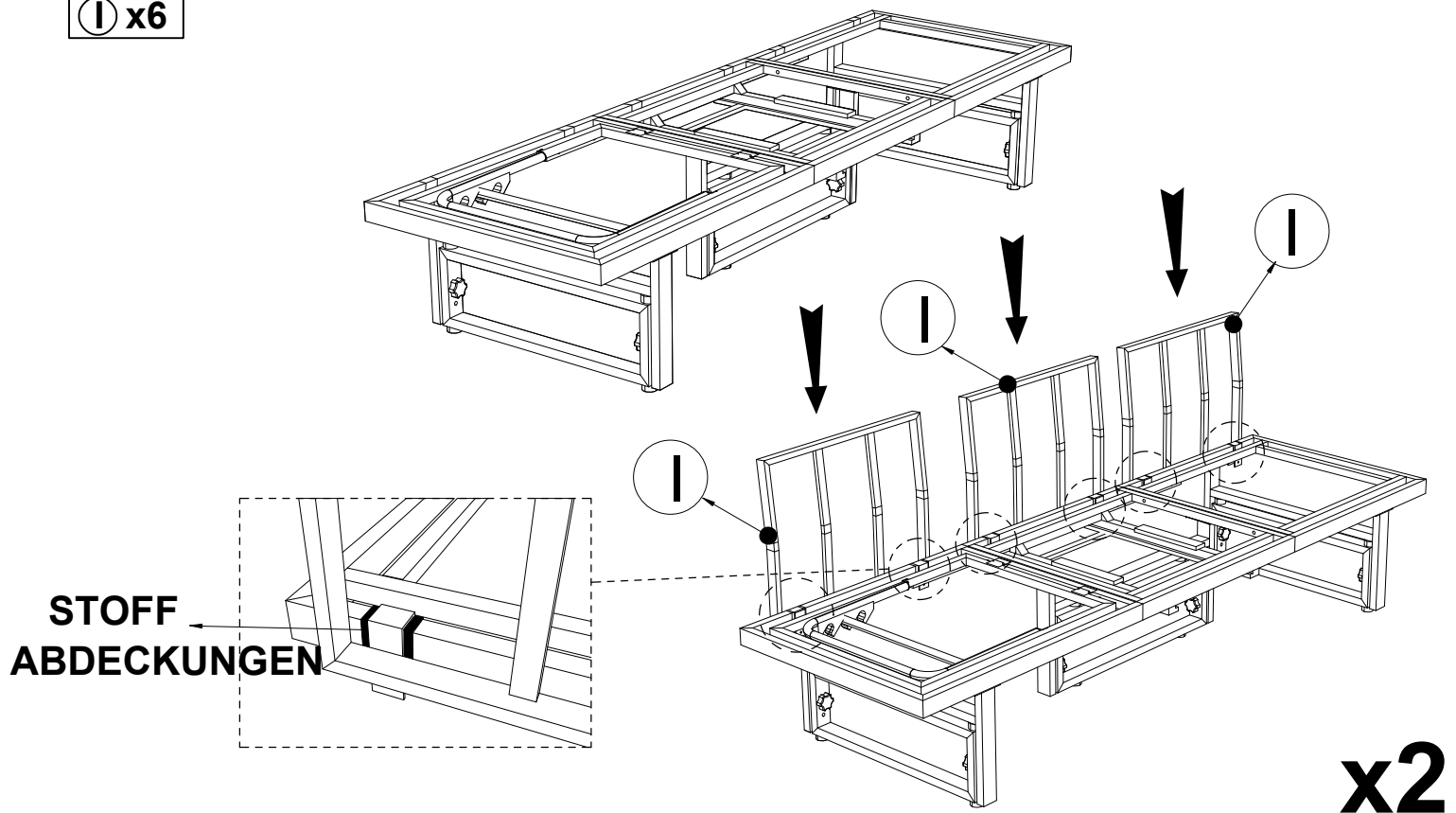

Stellen Sie die Bank aufrecht und schieben Sie die Bank (I) mit den Stoffbezügen in die richtige Position

# SCHRITT 18

⑧ x6

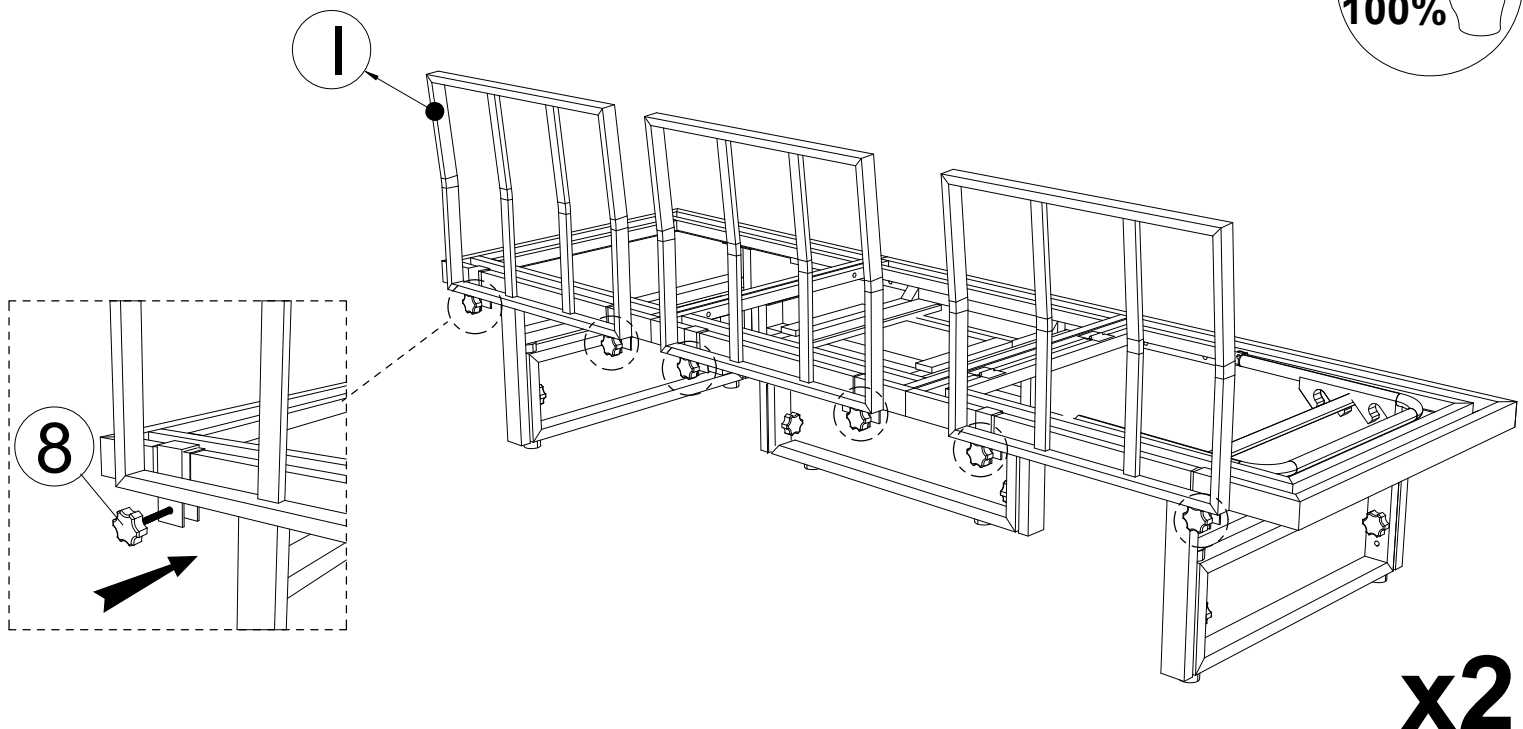

Halten Sie den festen Bolzen (8) mit der Hand fest und ziehen Sie ihn fest

# SCHRITT 19A

Ändern Sie die Höhe  
der Beinbank

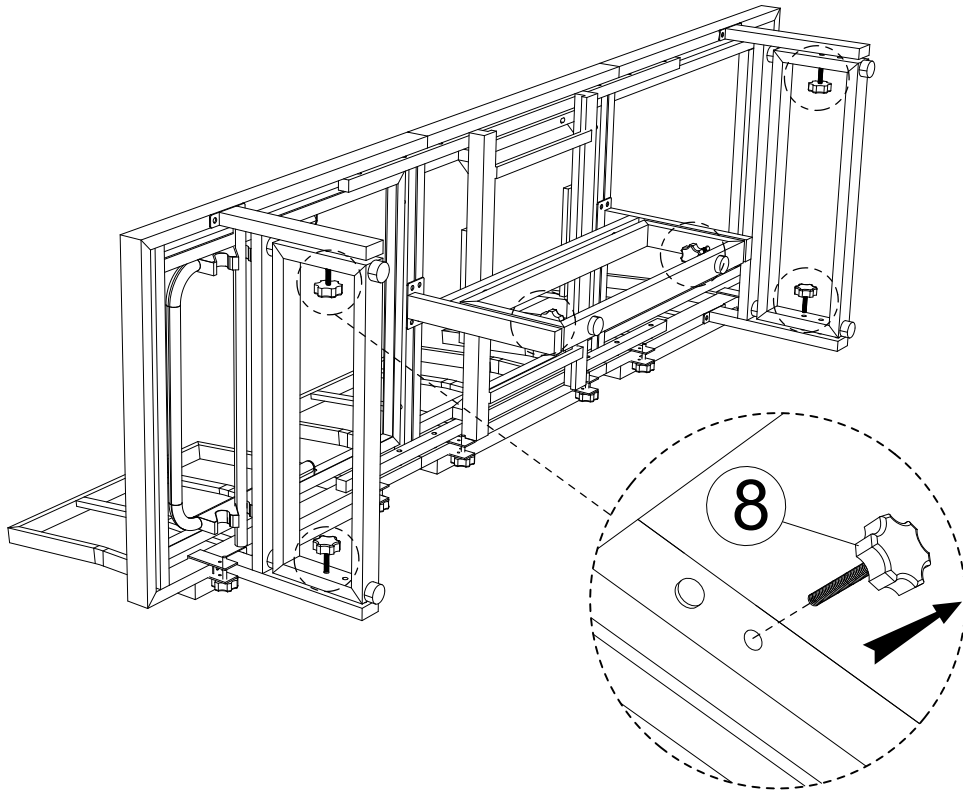
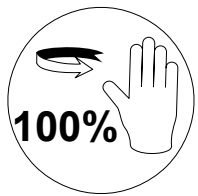

x2

Lösen und entfernen Sie die feste Schraube (8).

# SCHRITT 19B

Ändern Sie die Höhe  
der Beinbank

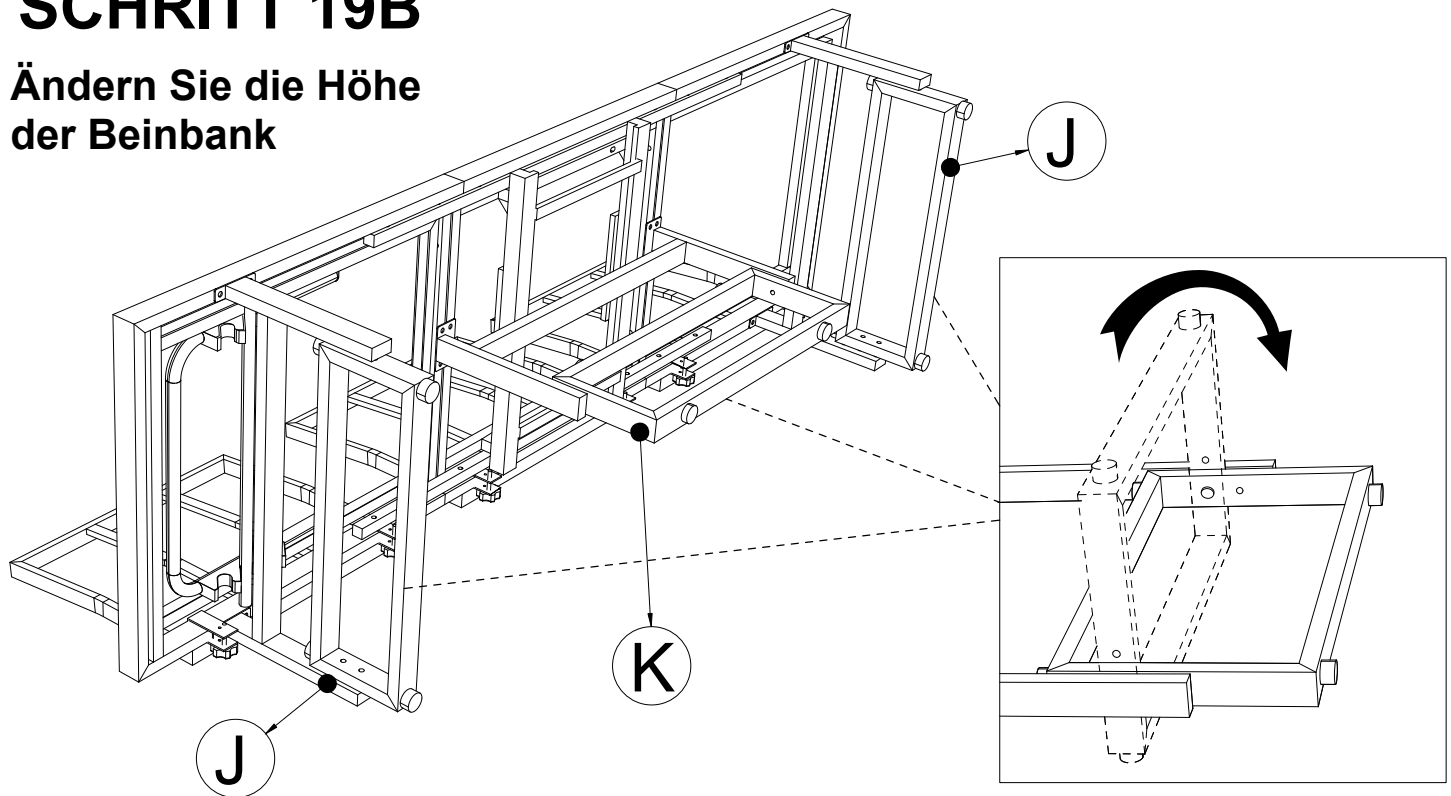

x2

Drehen Sie den inneren Teil von (J) und (K) um den Winkel 180°

## SCHRITT 19C

Ändern Sie die Höhe  
der Beinbank

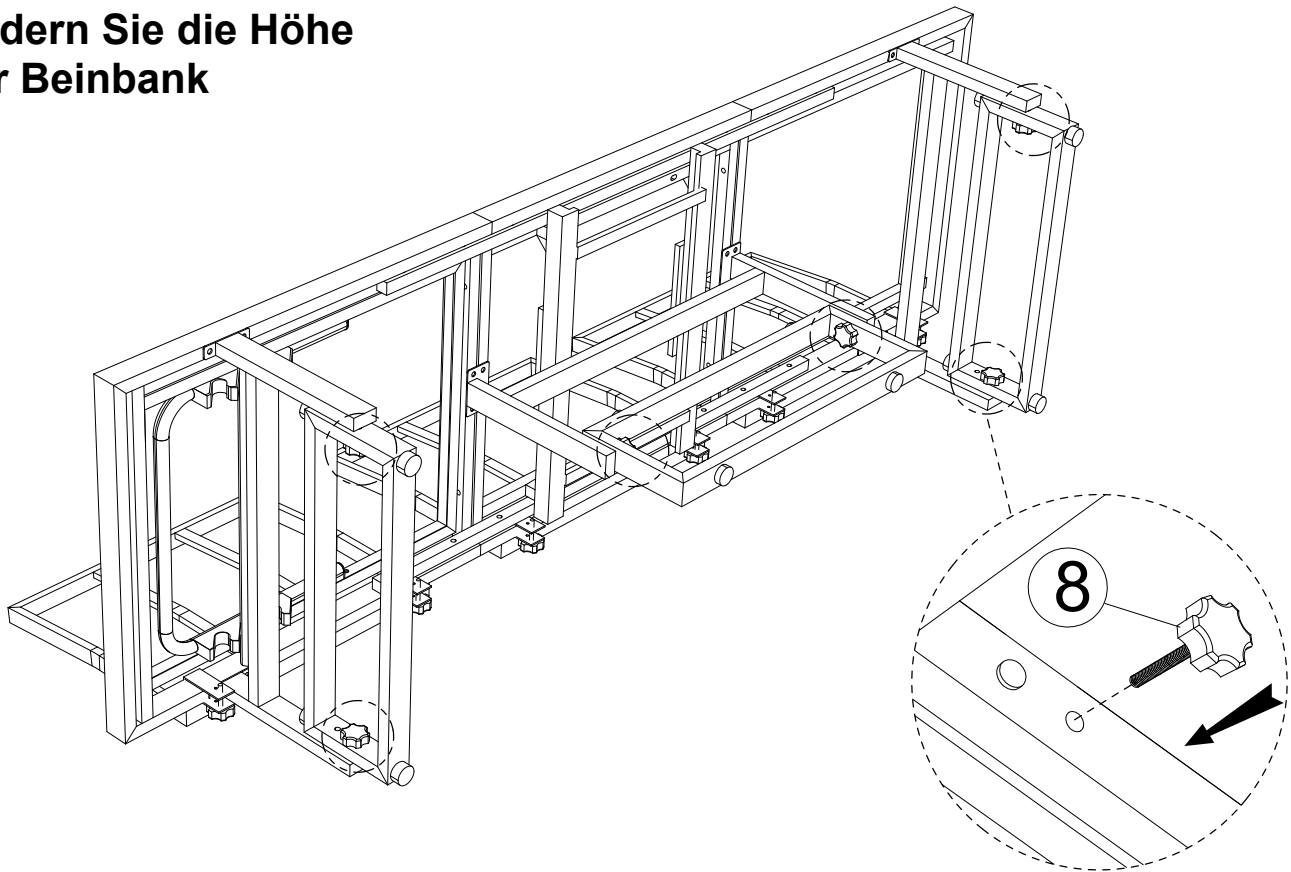

Festen Bolzen (8) handfest anziehen

## SCHRITT 19D

Ändern Sie die Höhe  
der Beinbank

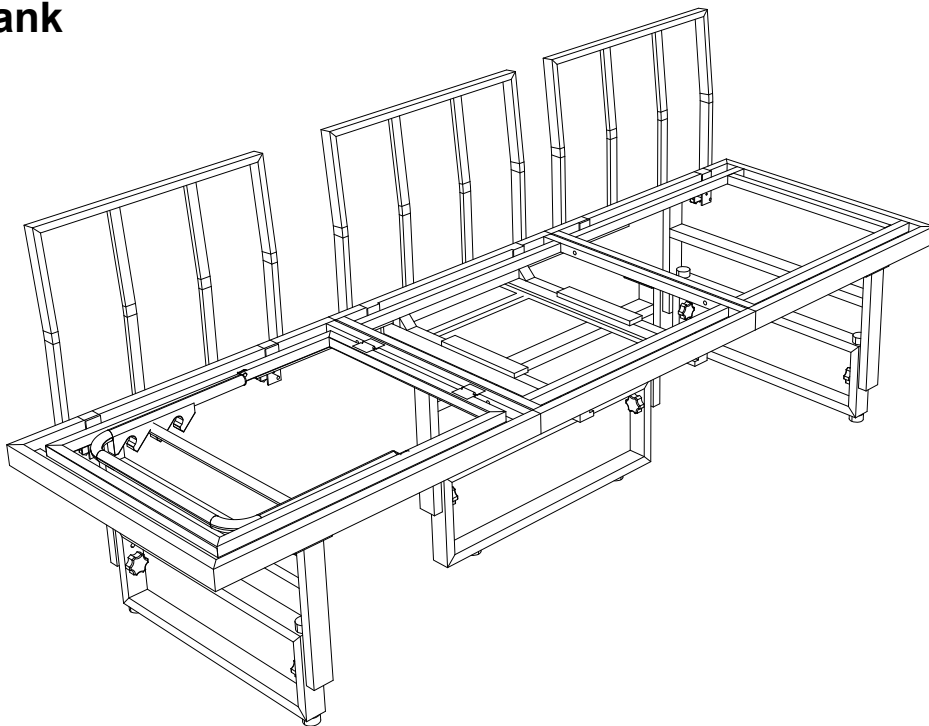

Je höher der Bankrahmen, desto höher

# SCHRITT 20

**S** x1

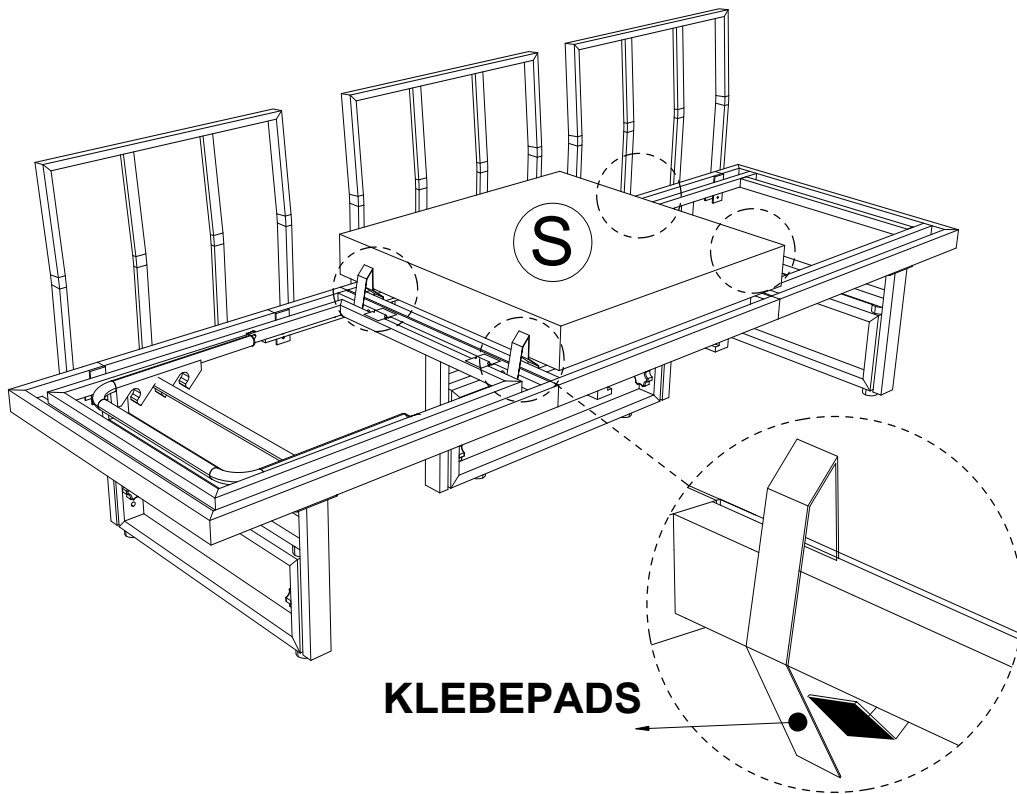

Platzieren Sie das Kissen (S) ab Schritt 18 auf der Sitzbank 2 (G).  
mit Klebepads.

# SCHRITT 21

**N** x2

**O** x1

**P** x1

**X** x1

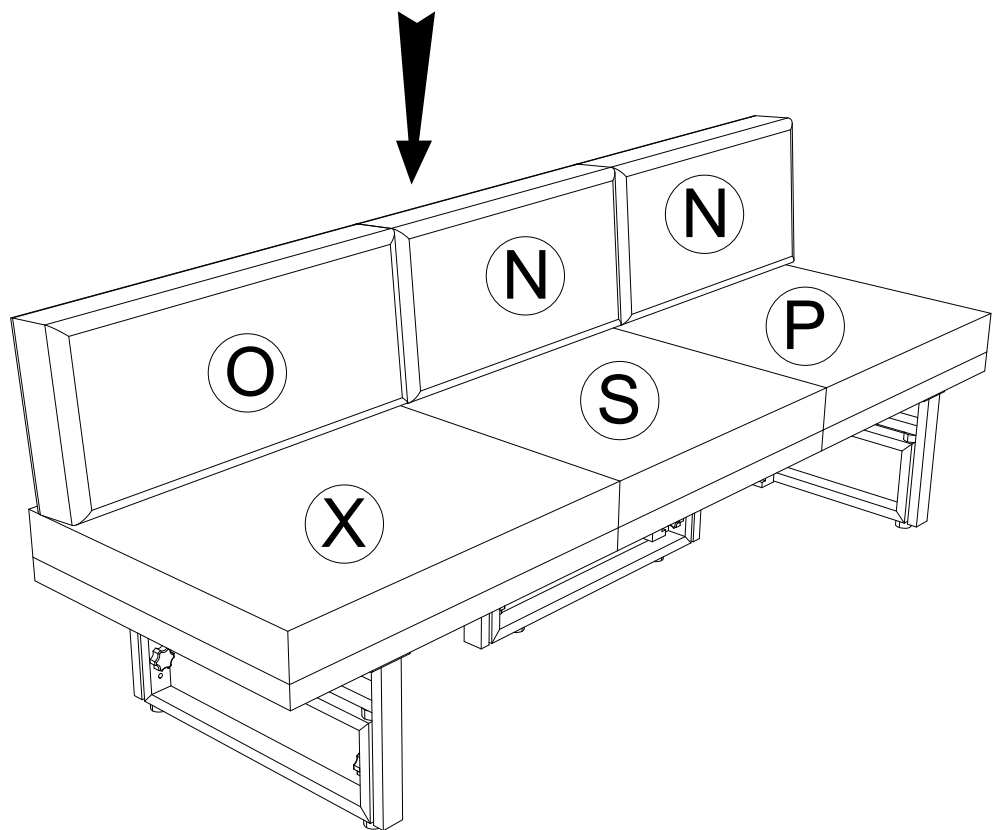

Platzieren Sie die Kissen (N)+(O)+(X)+(P).

# SCHRITT 22

**D** x1

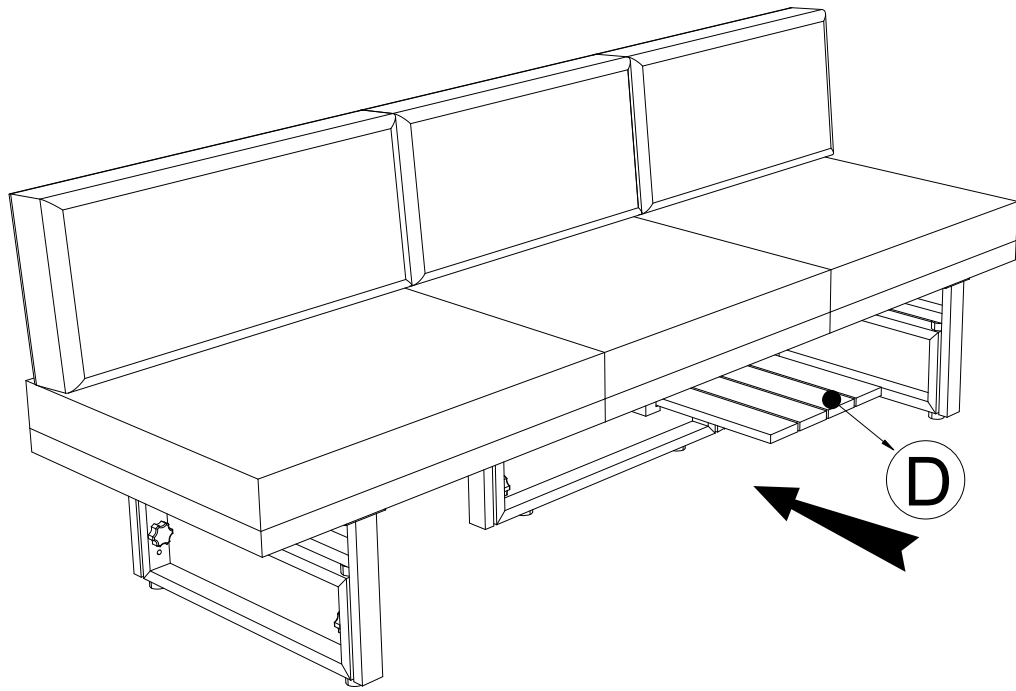

**Stellen Sie den Beistelltisch (D) in das Holztablett und schieben Sie ihn hinein.**



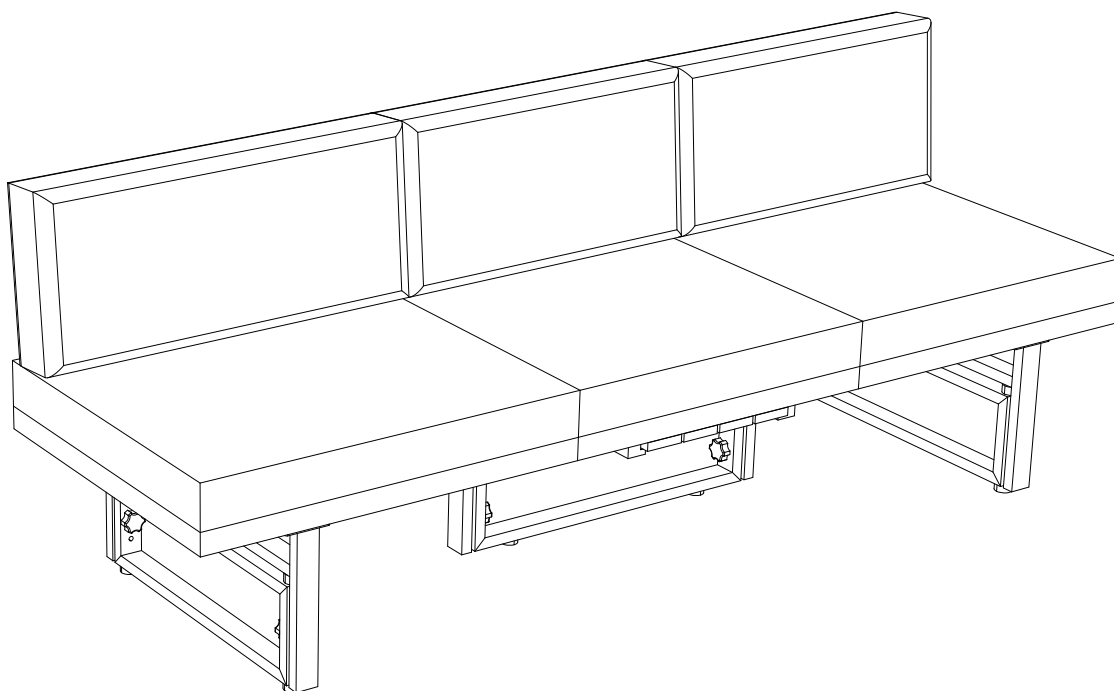

**Beende die Bank**

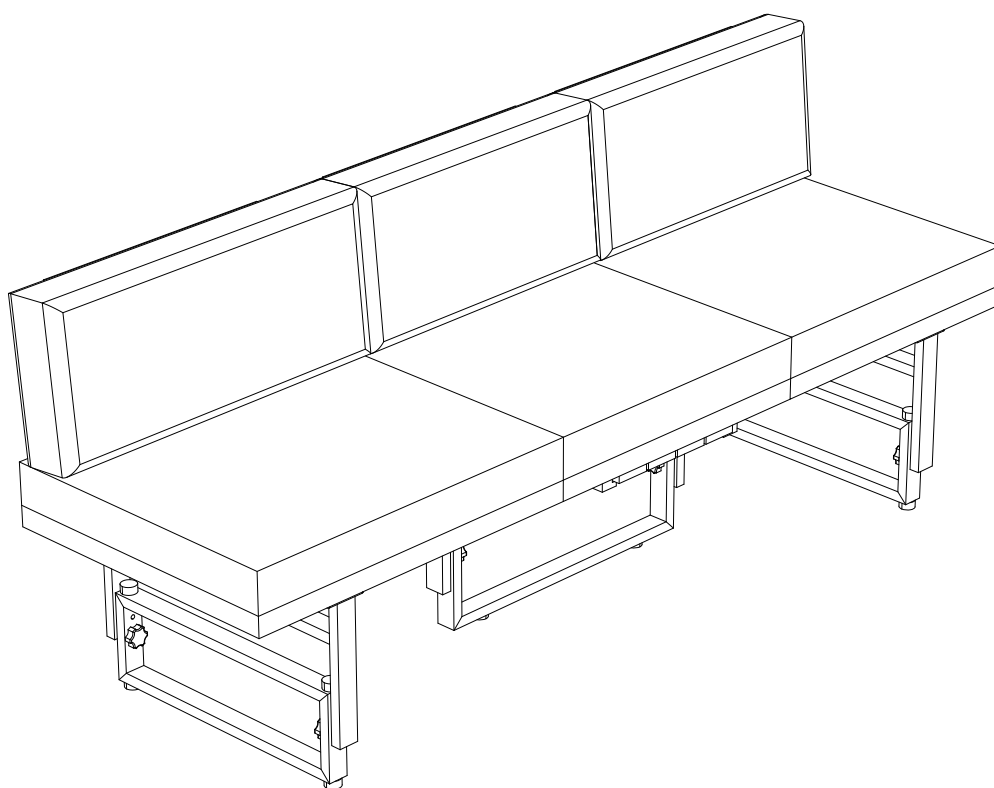

**Beenden Sie die höhere Bank**

## SCHRITT 23

Ändern Sie die Sitze  
von Bank

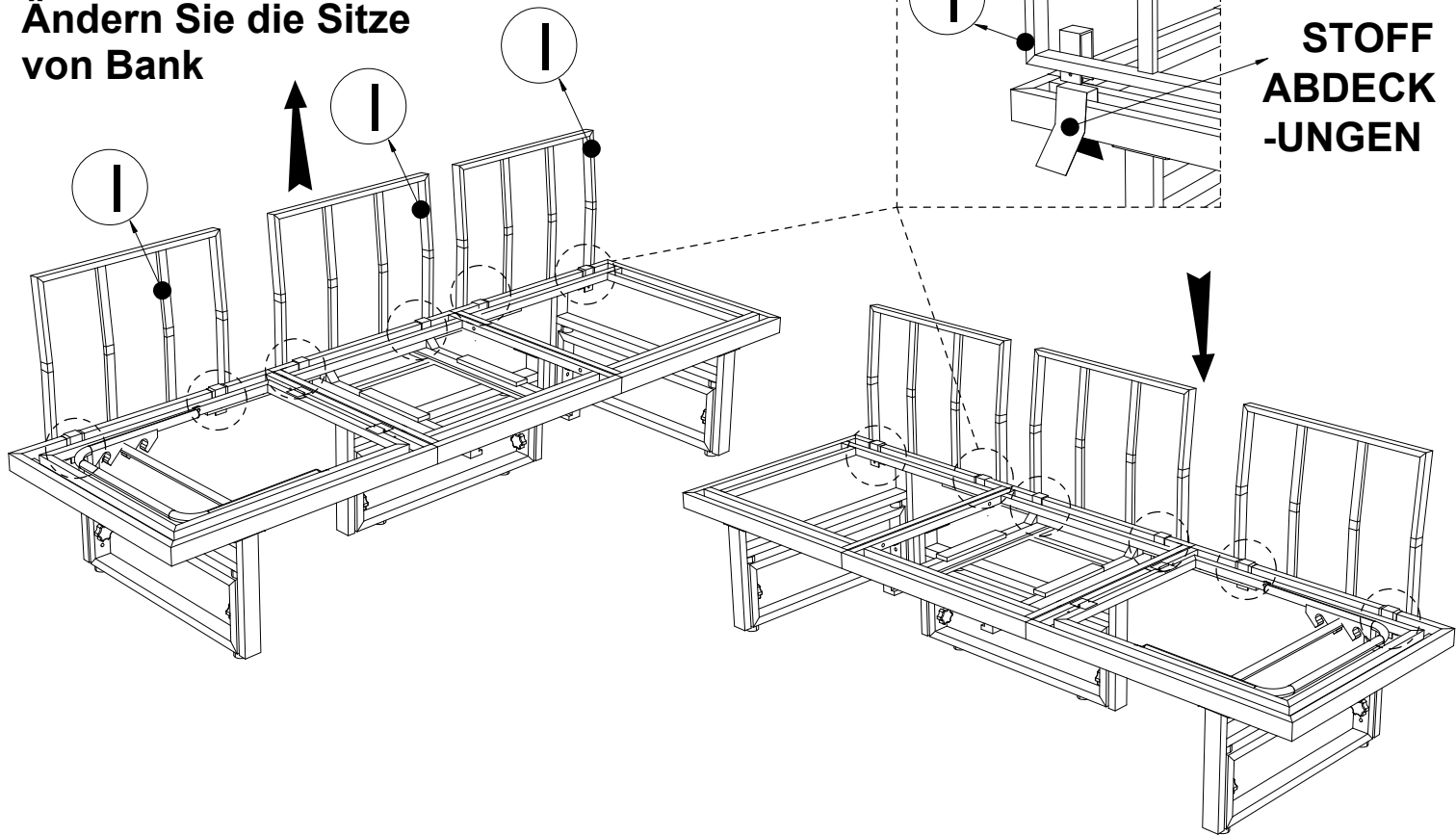

Ersetzen Sie ab Schritt 18 alle Rückenlehnen der Bank (I) durch Stoffbezüge zur gegenüberliegenden Seite.

## SCHRITT 24

Ändern Sie die Sitze  
von Bank

Ⓢ x1

Ⓝ x2

Ⓞ x1

Ⓟ x1

ⓧ x1

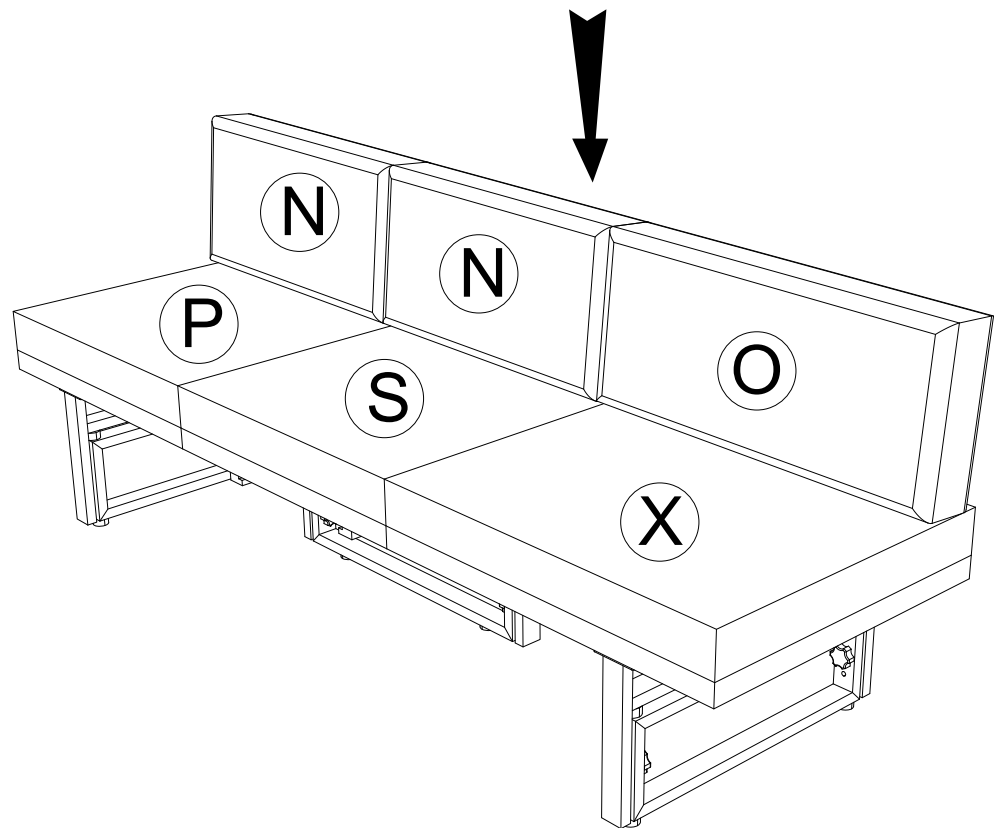

Richten Sie alle Kissen erneut wie in den Schritten 20 und 21 beschrieben ein

# SCHRITT 25

**D** x1

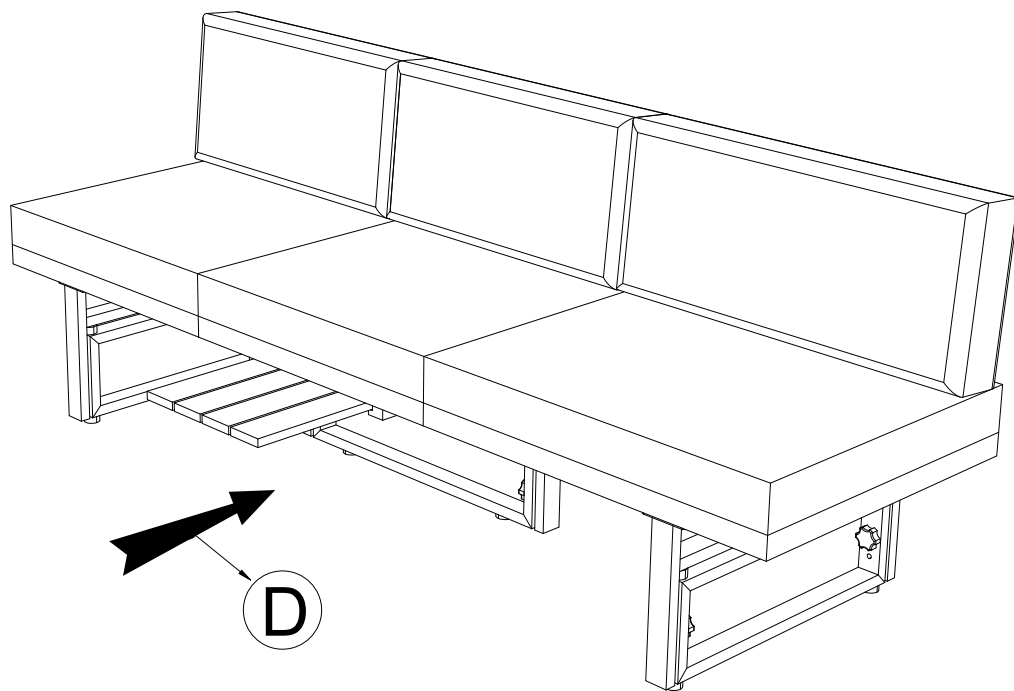

**Stellen Sie den Beistelltisch (D) in das Holztablett und schieben Sie ihn hinein.**

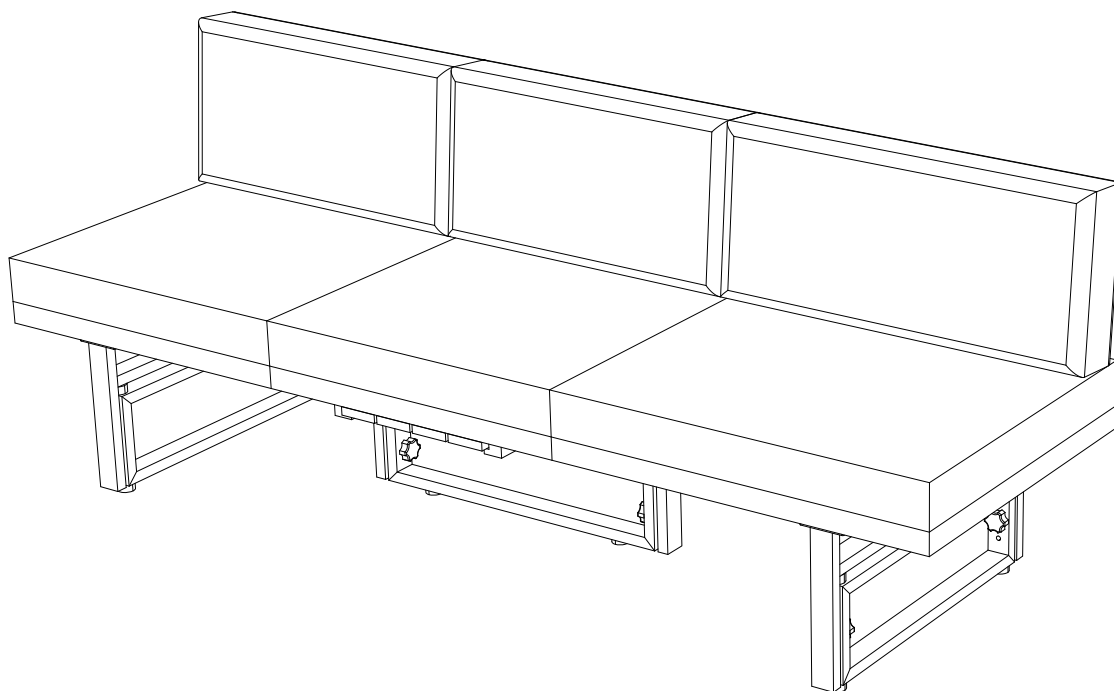

**Beende die Bank**

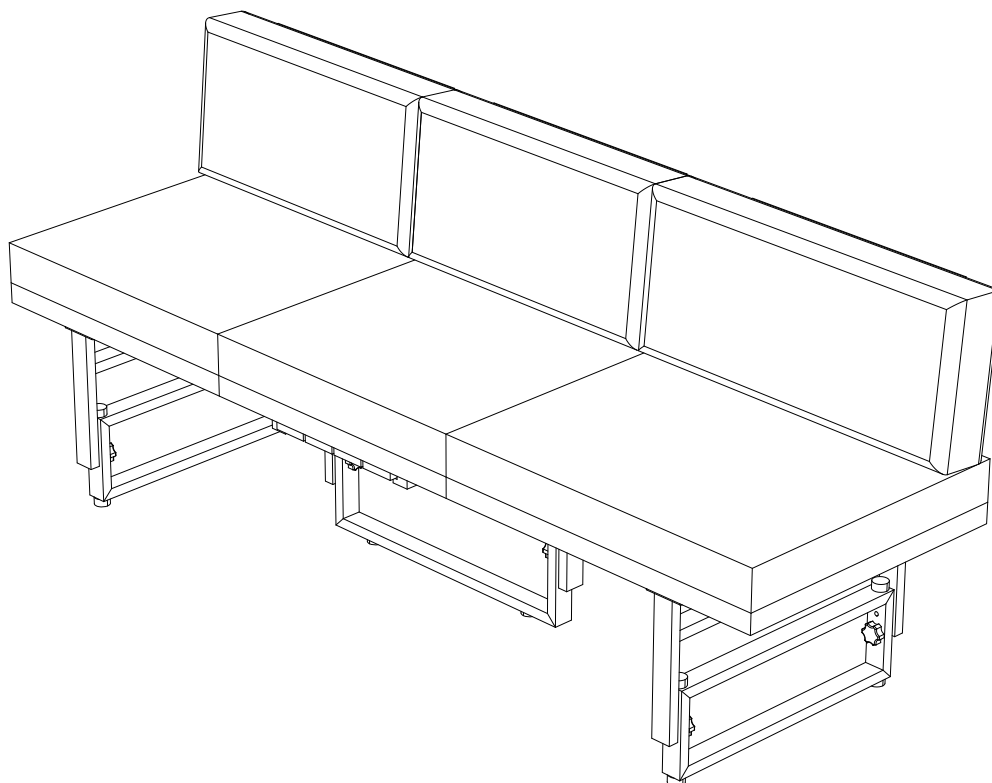

**Beenden Sie die höhere Bank**

## SCHRITT 26

Ändern Sie die Sitze  
von Bank

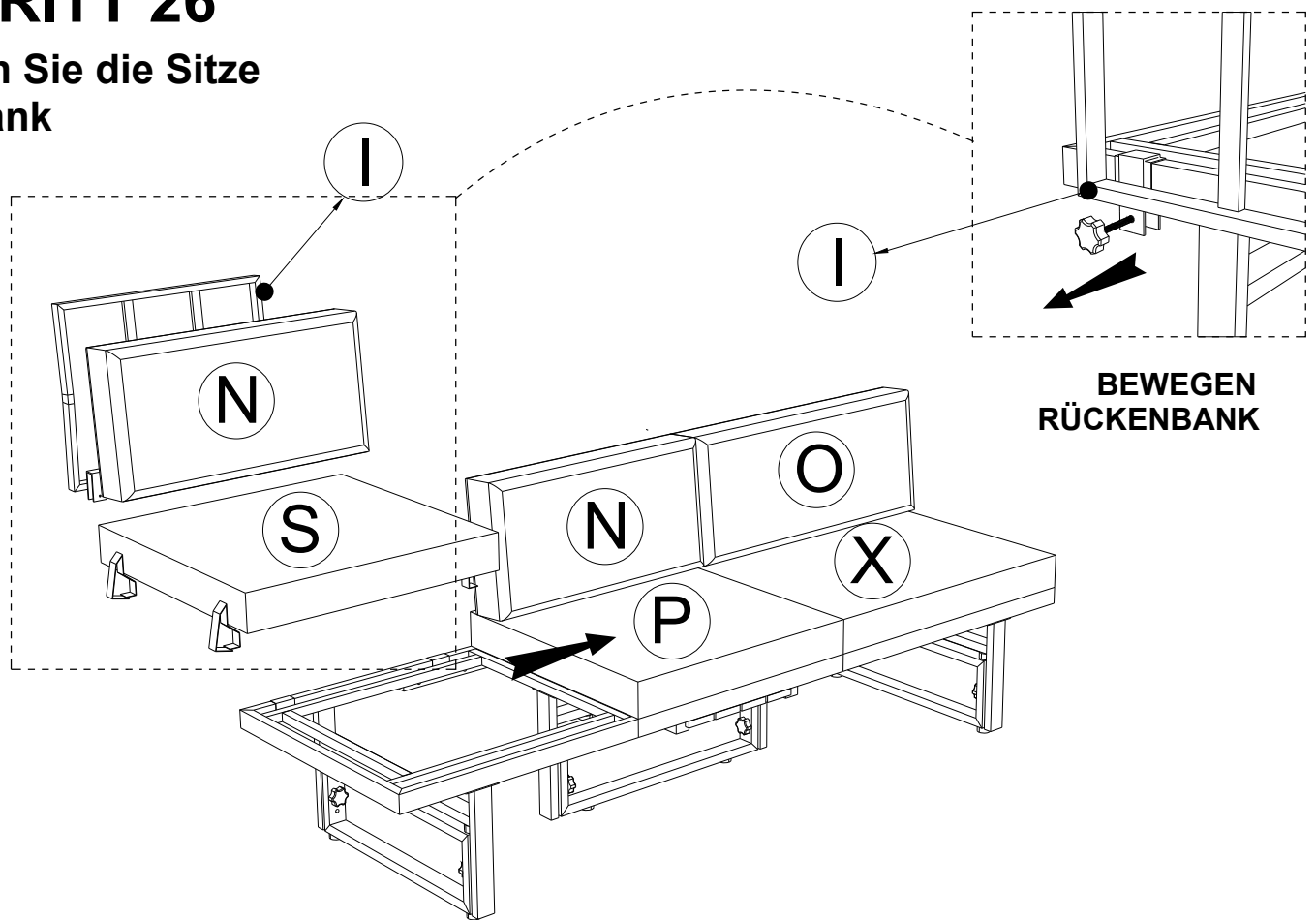

Entfernen Sie einige Details (I)+(N)+(S) und passen Sie die Kissen erneut an

## SCHRITT 27

Ändern Sie die Sitze  
von Bank

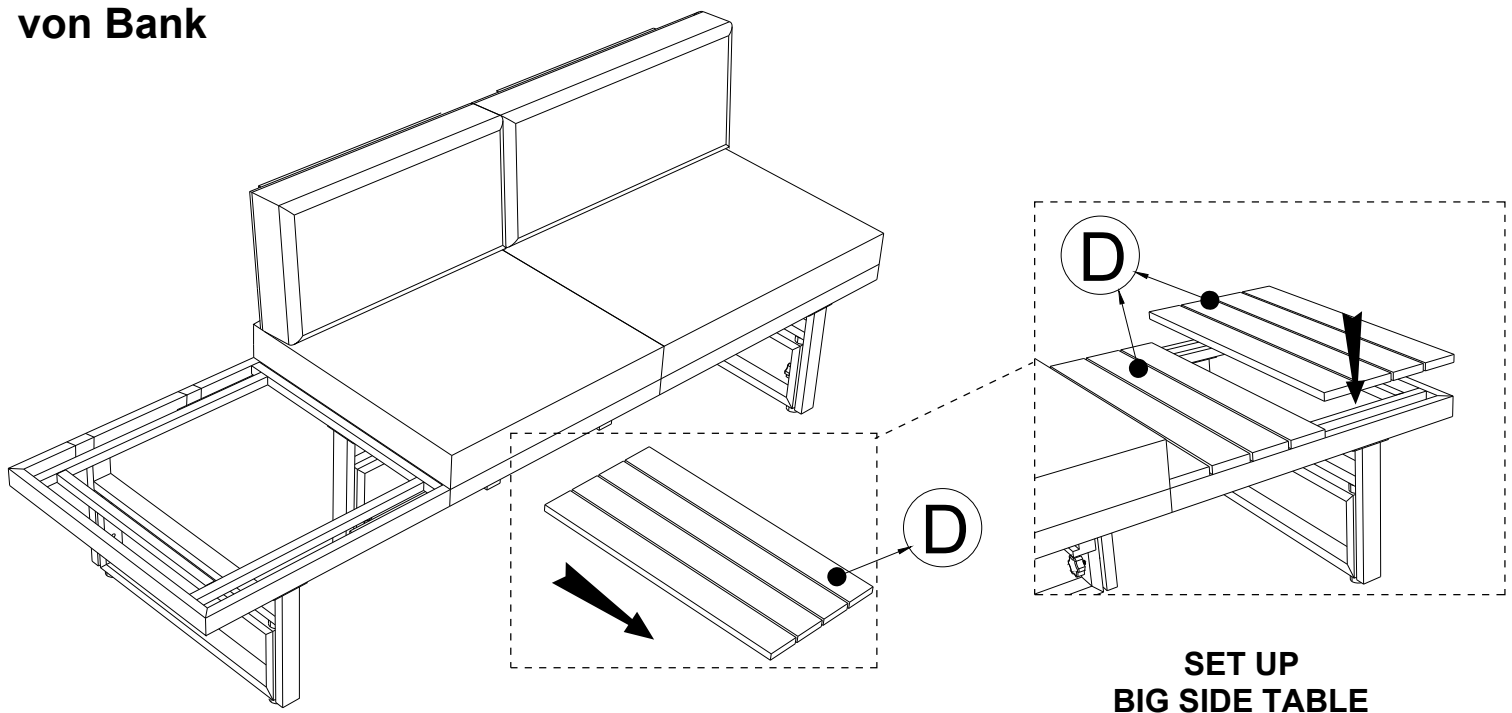

Entfernen Sie das Detail (D) von den Bänken und verbinden Sie die beiden  
Teile mit dem großen Beistelltisch.

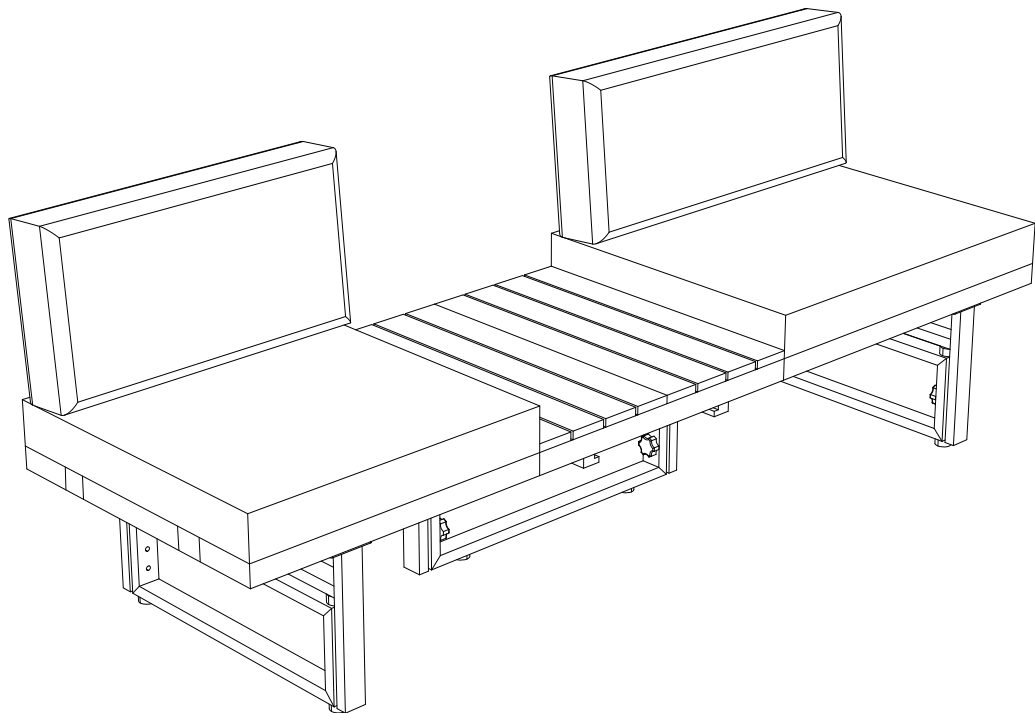
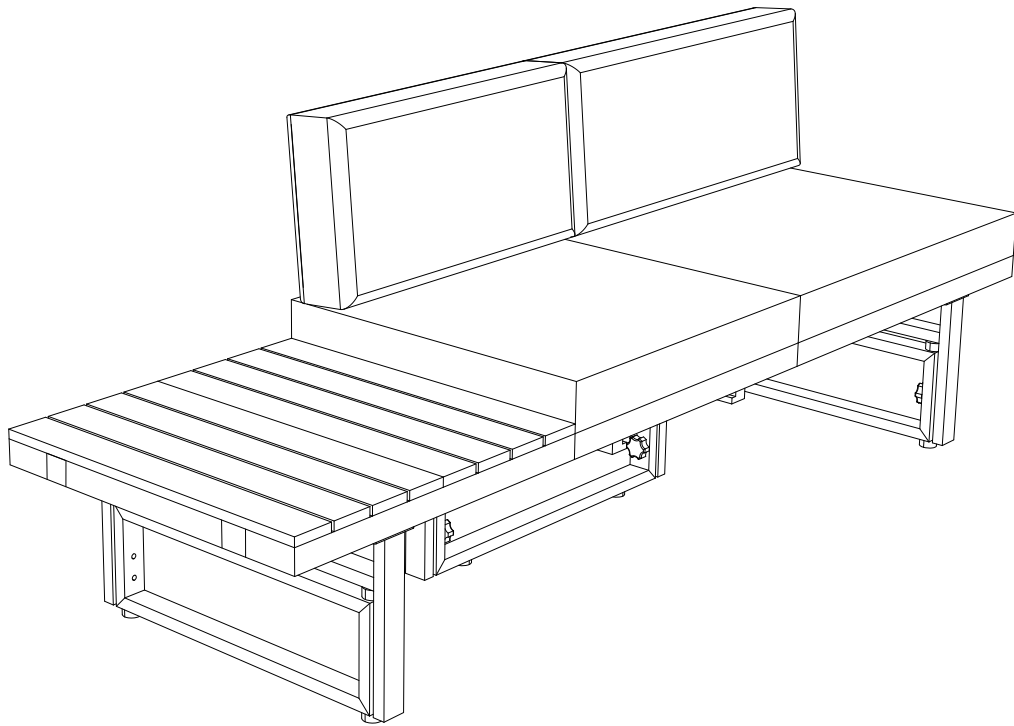

**Beenden Sie den Sharp of Bench**

## SCHRITT 28

Ändern Sie die Sitze  
von Bank

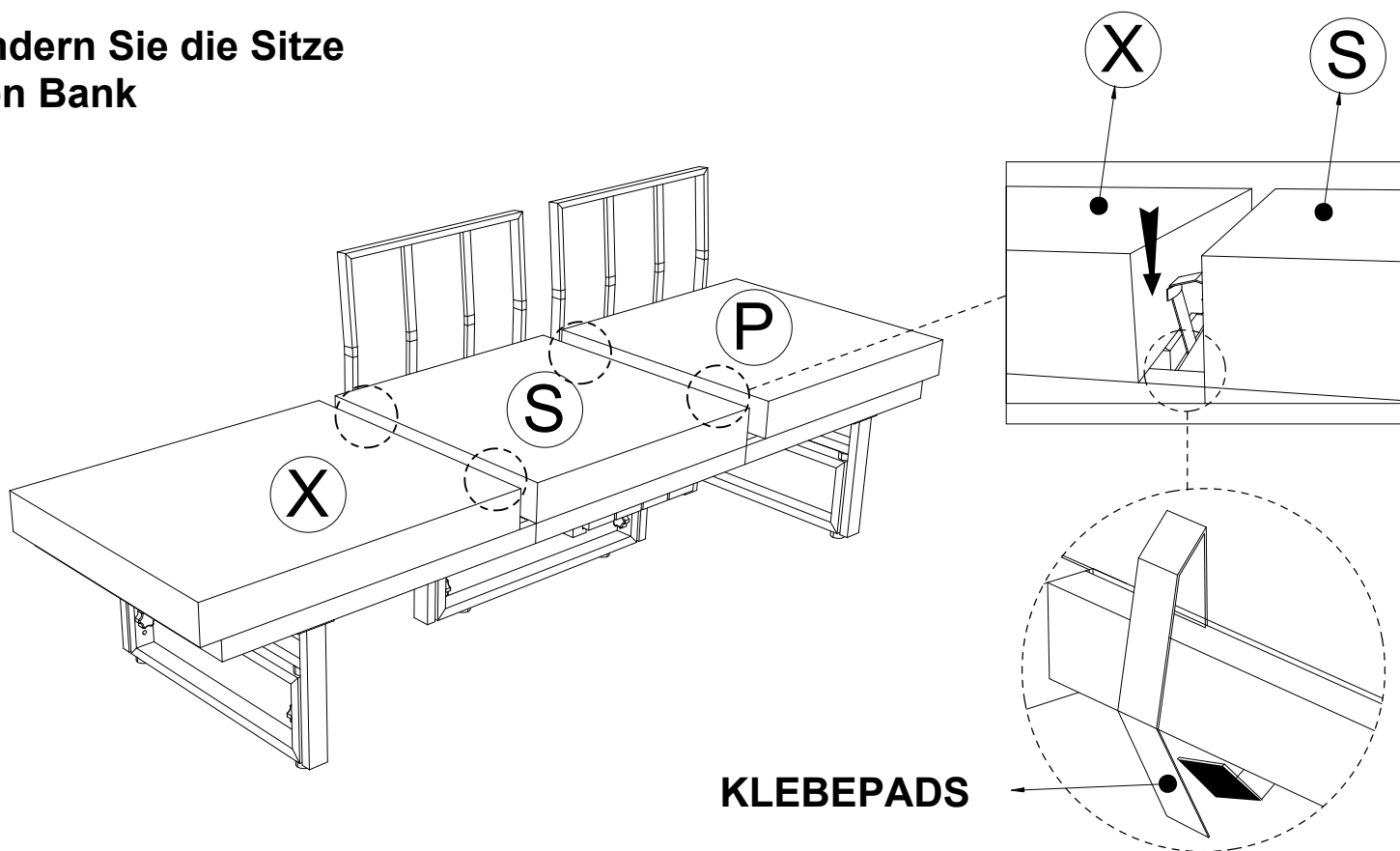

Entfernen Sie die Kissen (N)

Verbinden Sie die Kissen (X)+(S)+(P) mit Klebepads.

## SCHRITT 29

Ändern Sie die Sitze  
von Bank

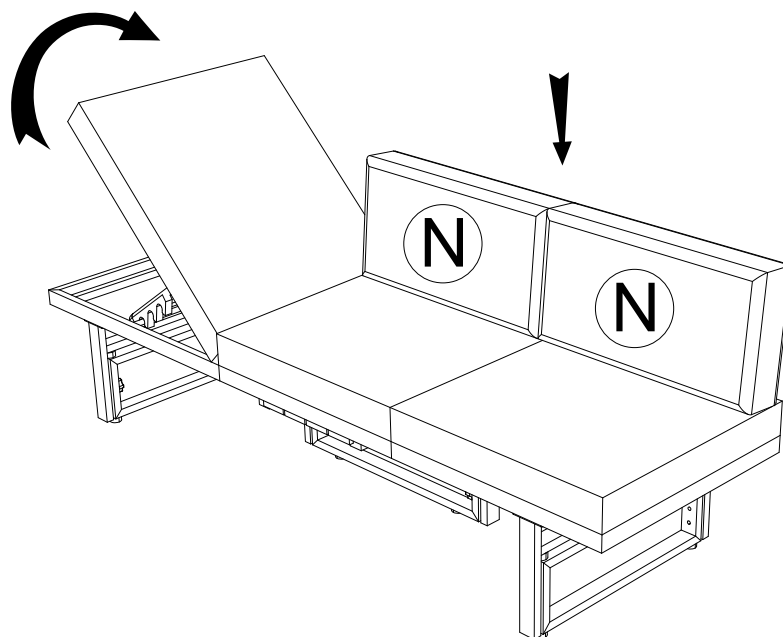

Verwenden Sie den Hebesatz von Teil (F), um die Rückenlehne für das fertige Bett herzustellen. Platzieren Sie die Kissen (N) erneut.

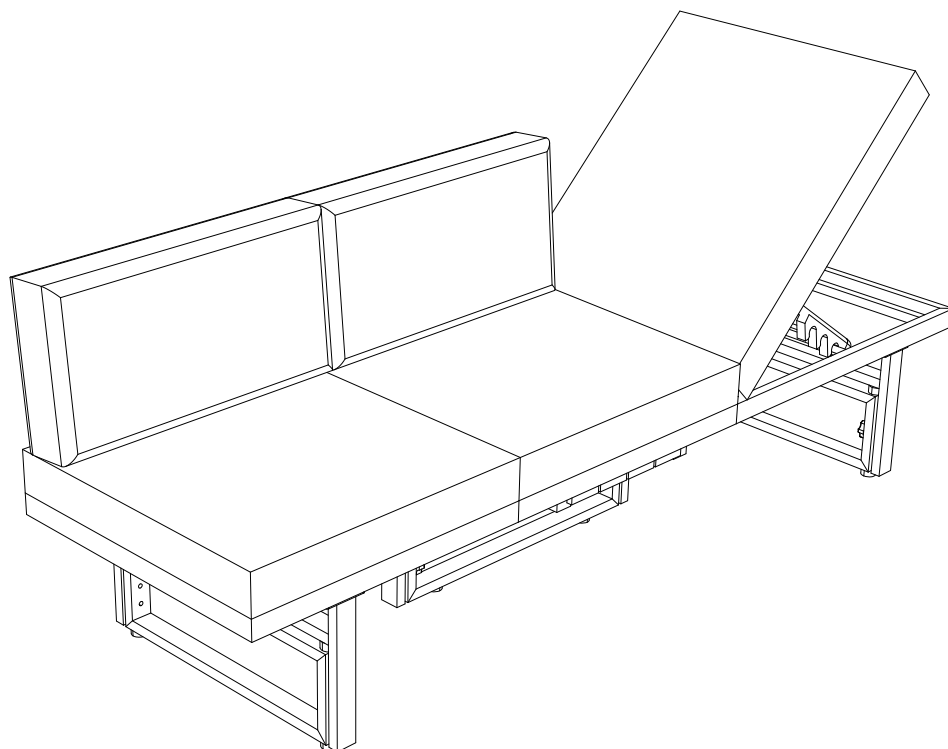
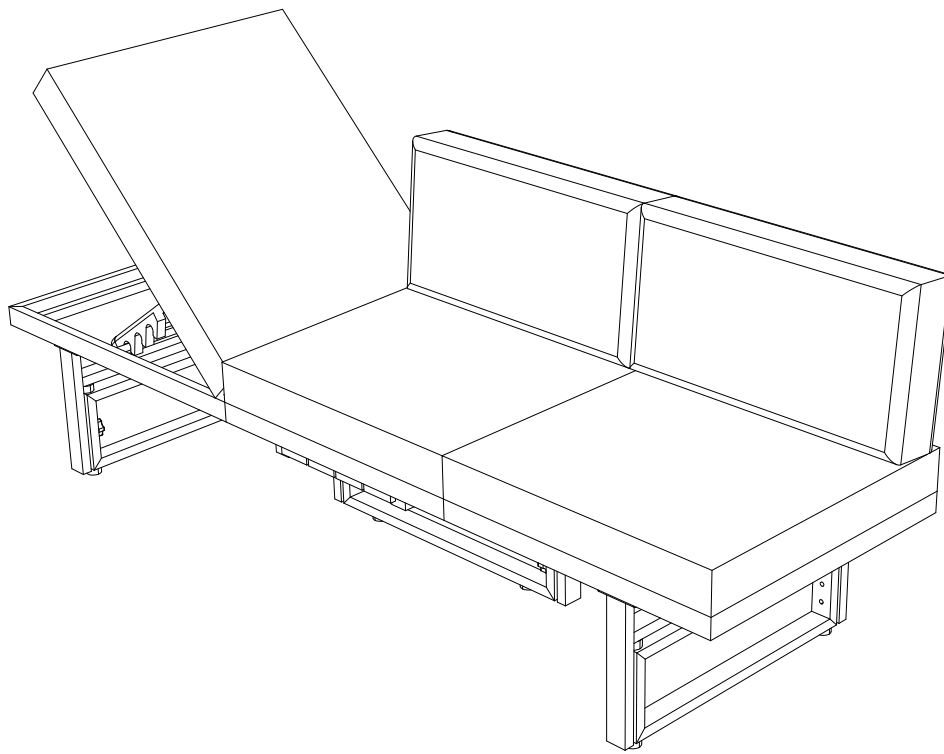

**Beenden Sie die scharfe Rückenlehne**



## SCHRITT 30

Ändern Sie die Sitze  
von Bank

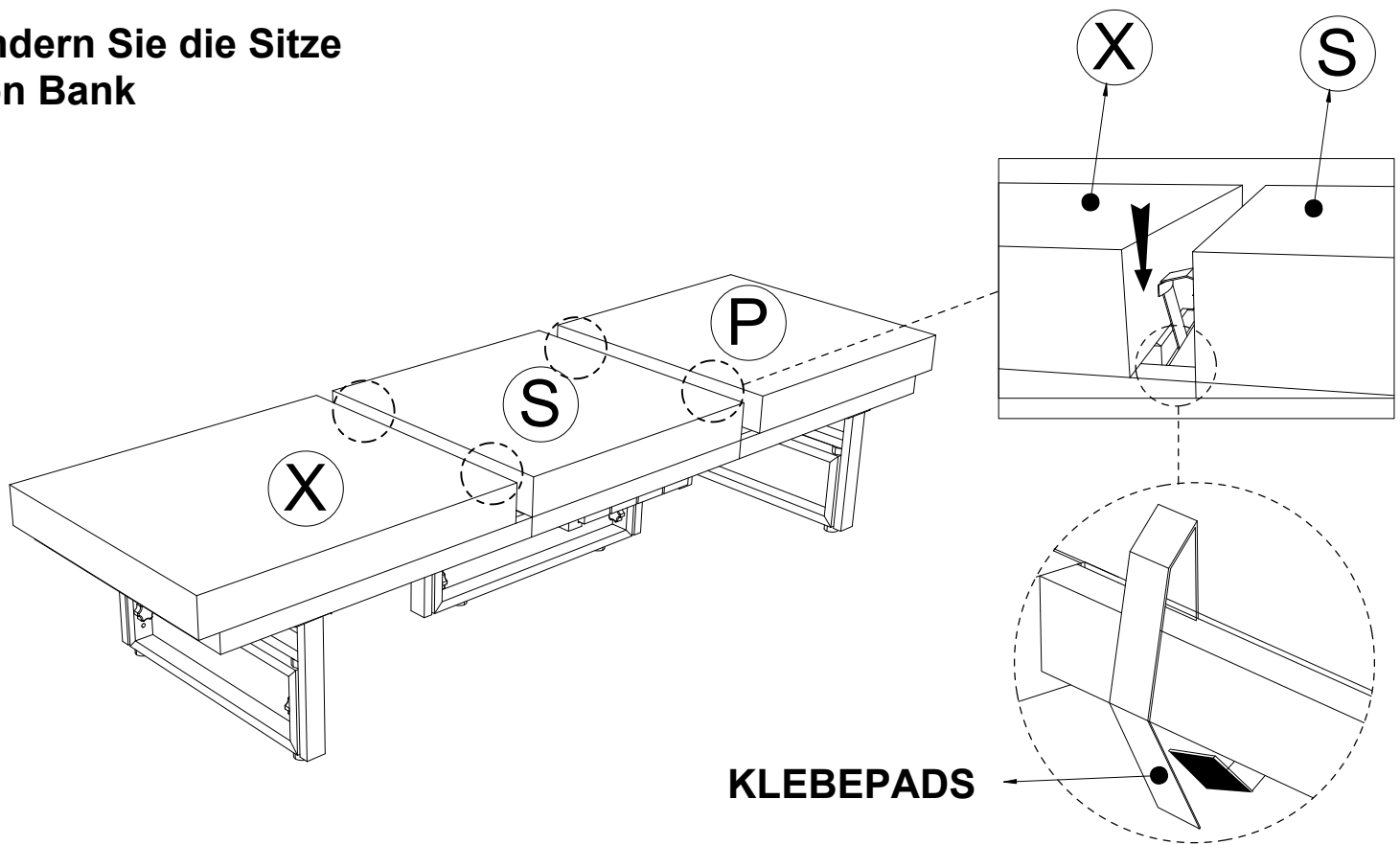

Entfernen Sie die Kissen (N) und die Rückbänke (I).  
Verbinden Sie die Kissen (X)+(S)+(P) mit Klebepads.

## SCHRITT 31

Ändern Sie die Sitze  
von Bank

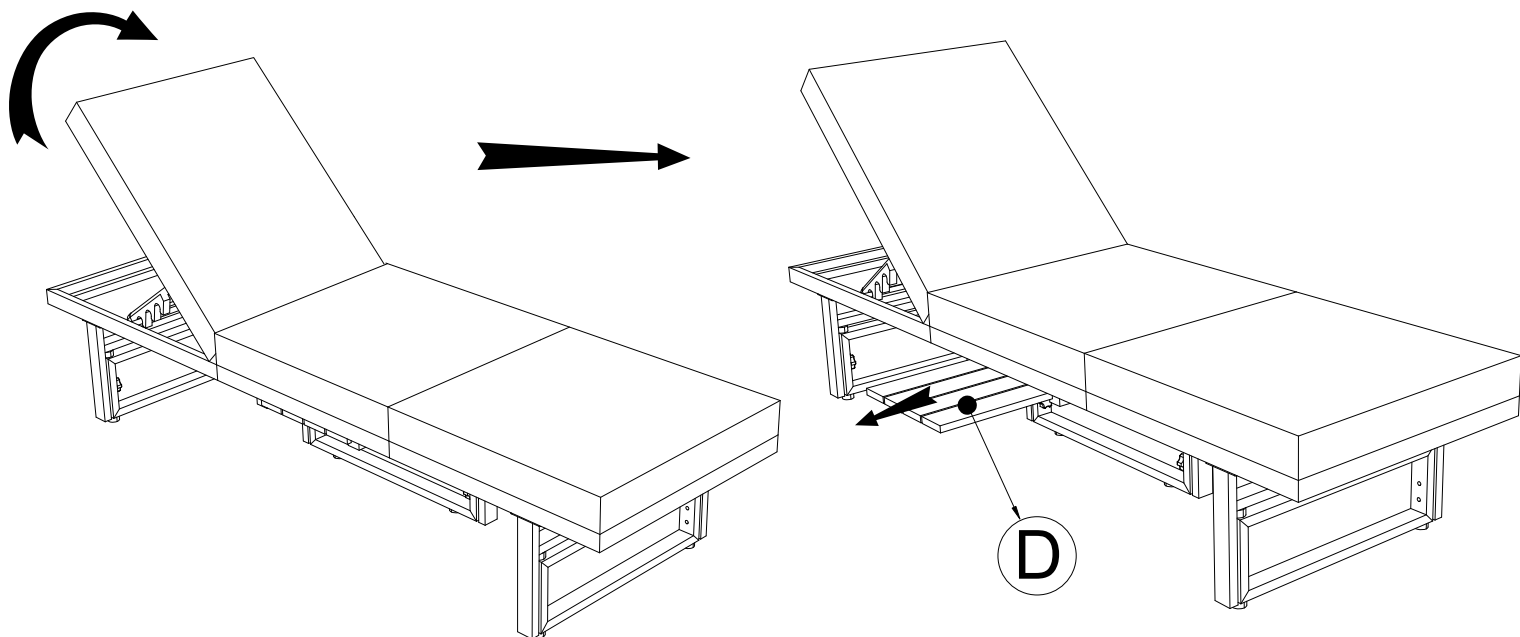

Verwenden Sie den Hebesatz von Teil (F), um die Rückenlehne für das fertige  
Bett herzustellen. Ziehen Sie den Beistelltisch (D) heraus, um ihn als Bett zu  
verwenden.

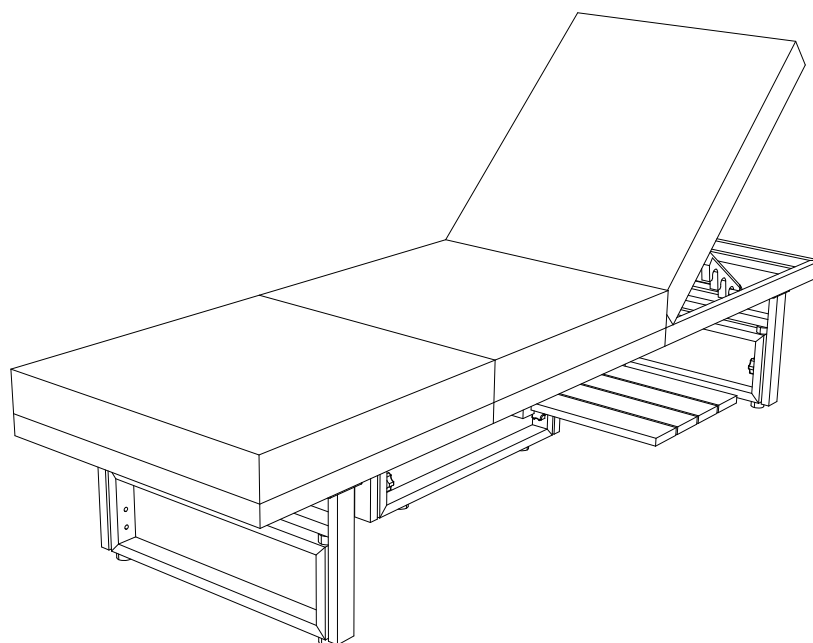
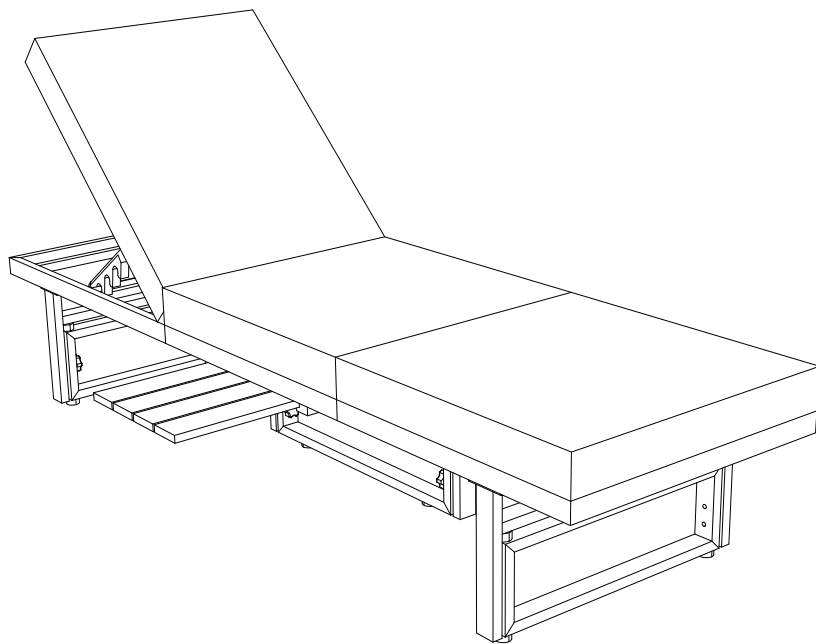

**Beenden Sie das Sharp-Bett**

