

Mette 3016

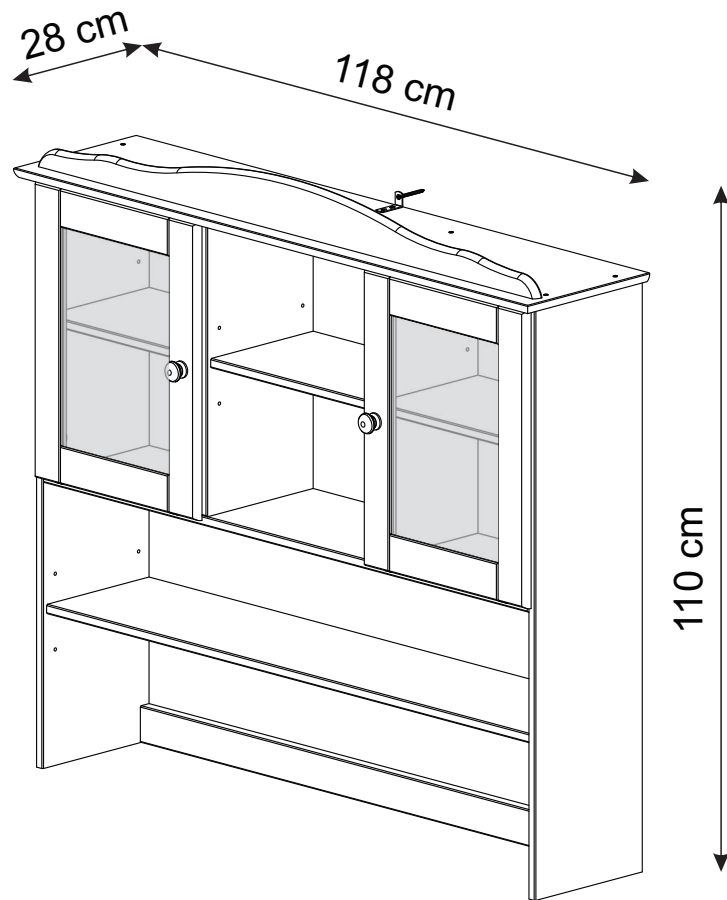

(D) Montageanleitung
3016

(FR) Notice de montage
3016

(NL) Handleiding voor de montage
3016

(CZ) Montážní návod
3016

(HU) Szerelési útmutató
3016

(TR) Montaj talimatı
3016

(GB) Assembly instructions
3016

(IT) Istruzioni di montaggio
3016

(PL) Instrukcja montażu
3016

(SK) Návod na montáž
3016

(RO) Instrucțiuni de montaj
3016



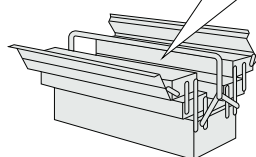
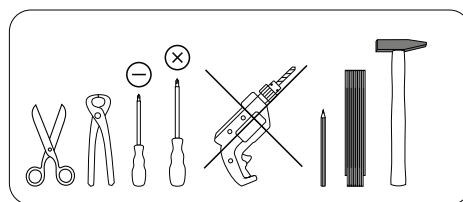
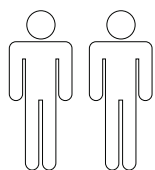





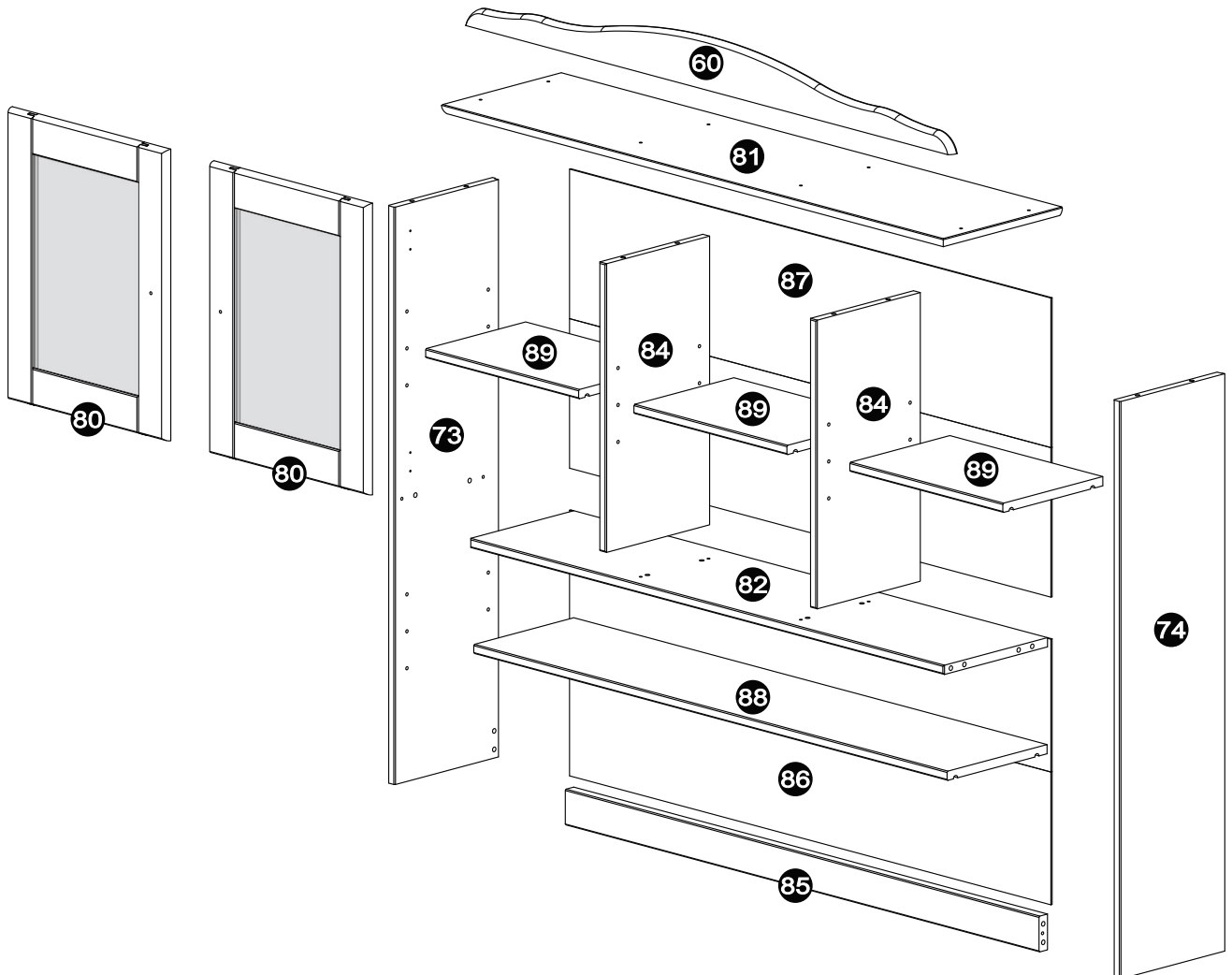
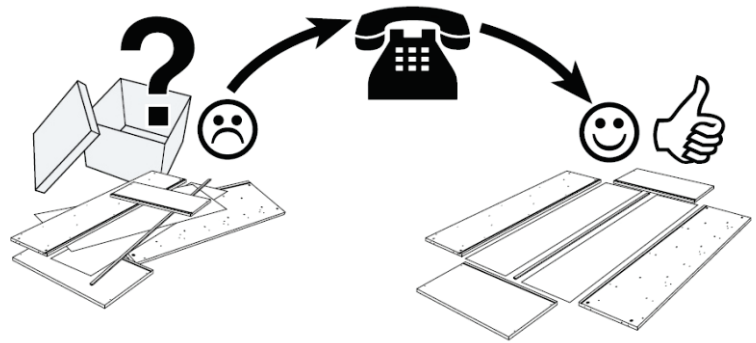
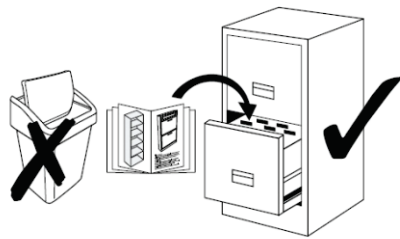





(RU) Инструкция по монтажу
3016



**Service • Assistenza • Dienstverlening • Serwis
Servis • Szerviz • Сервисная служба**

Name • Nom • Nome • Naam • Nazwa • Jméno • Názov • Név • Denumire • Isim • Название	
Nr. • No. • N° • Номер • Č • Sz	
Typ • Type • Tip • Típus • Tipo • Тип	
	



A  8,0x30 20x	B  4x	C  16x	D  3,5x14 30x	E  3x	F  2x	G  4x	H  4x35 16x	I  43x
J  7x	K  2x	L  C7 4x	M  1x	N  4,5x60 1x				

1

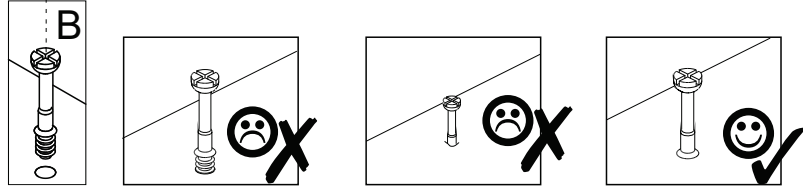
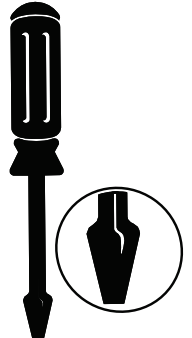
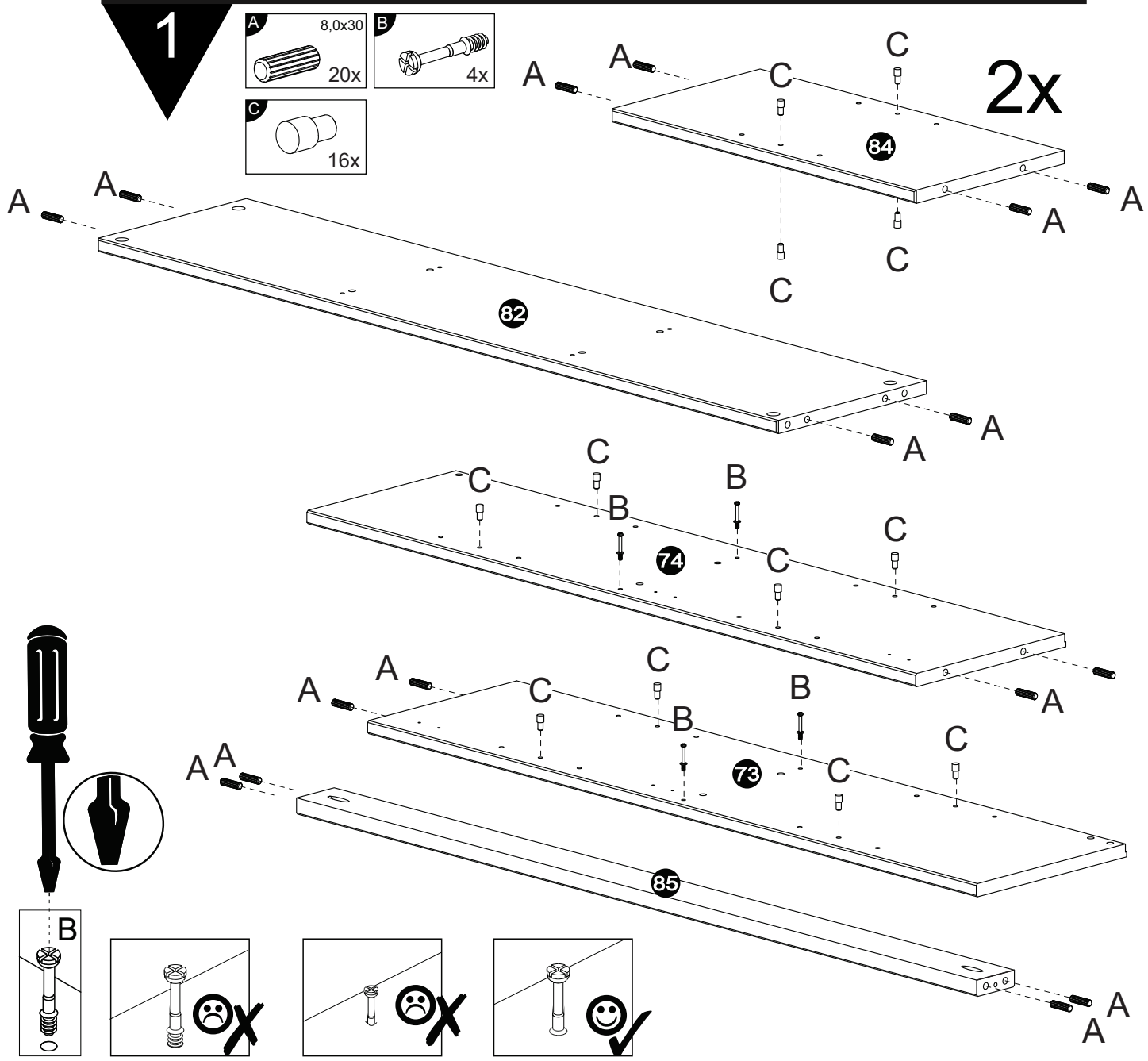
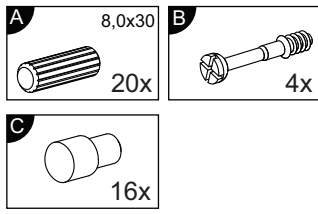

2

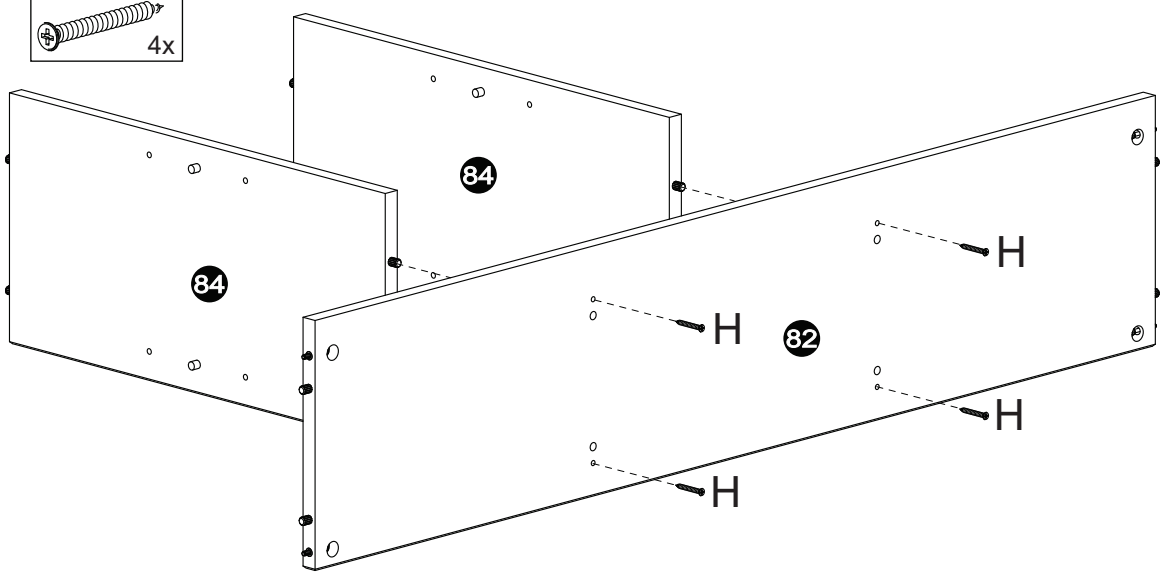
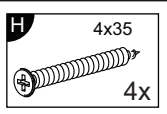

3

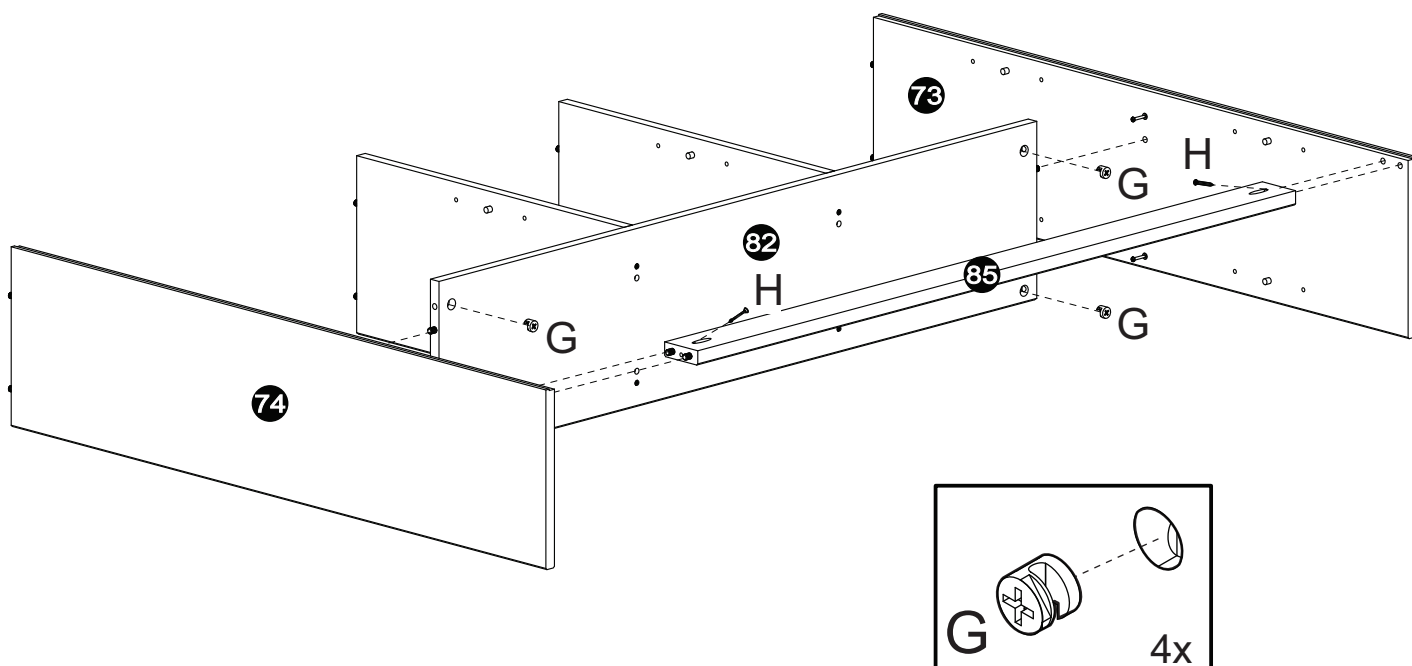
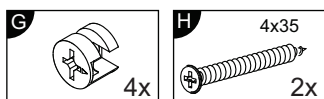

4

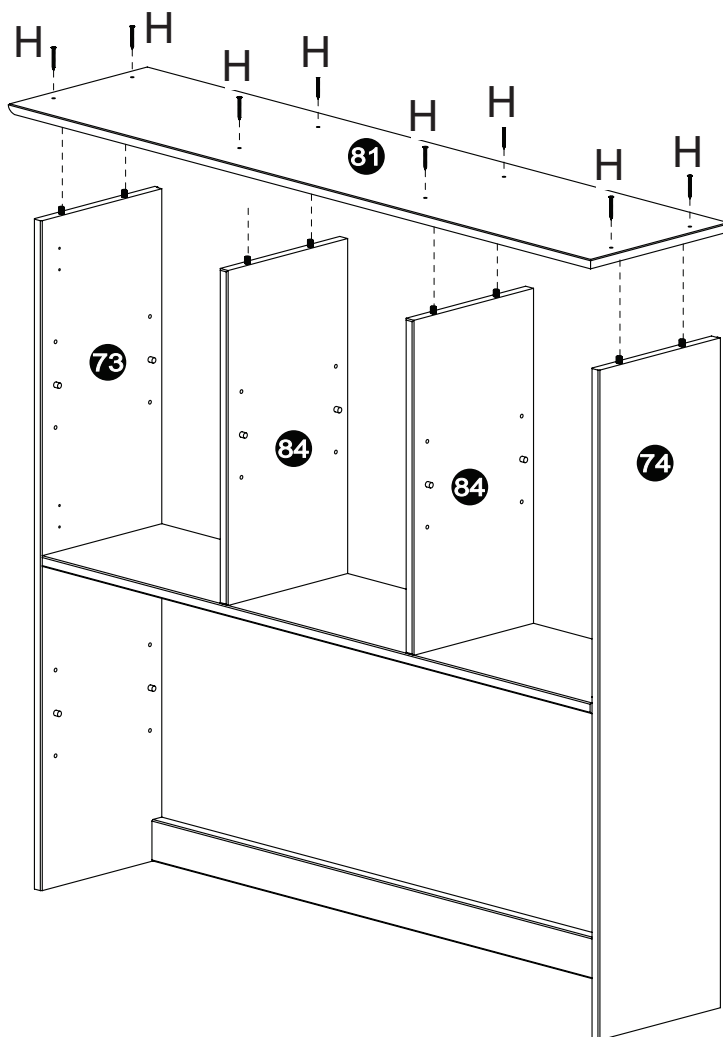
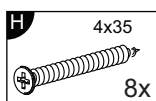

5

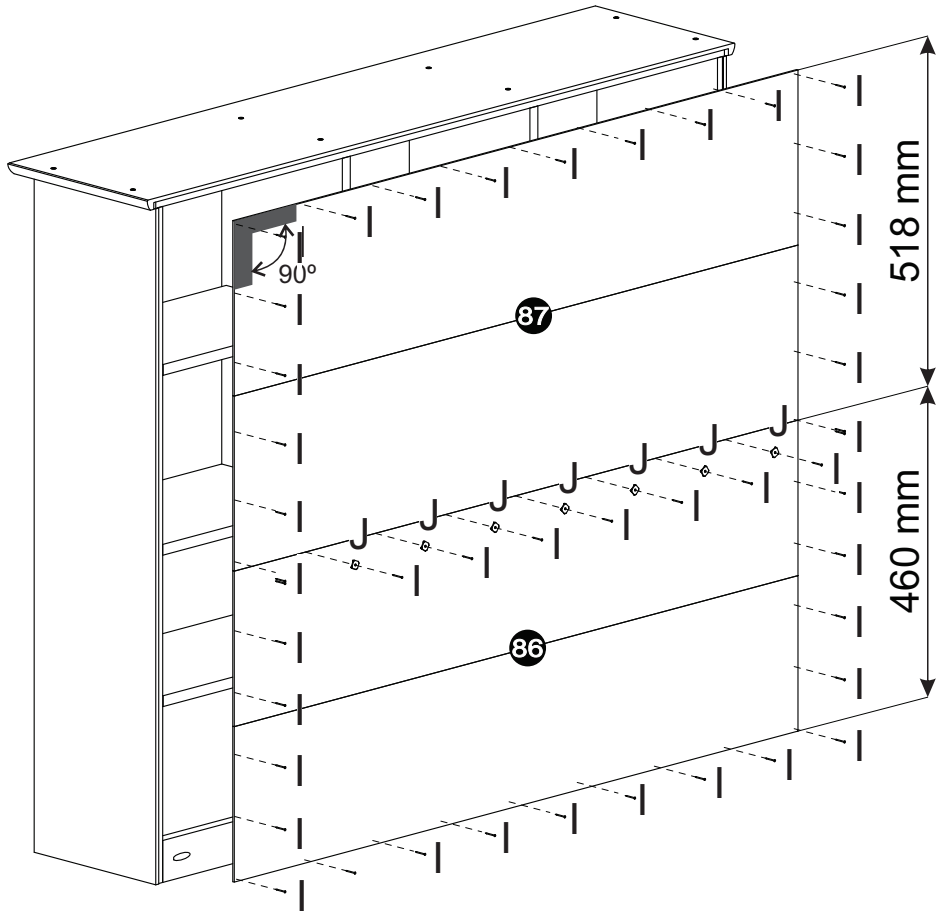
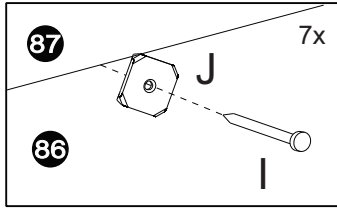
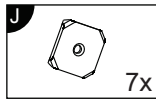
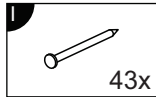

6

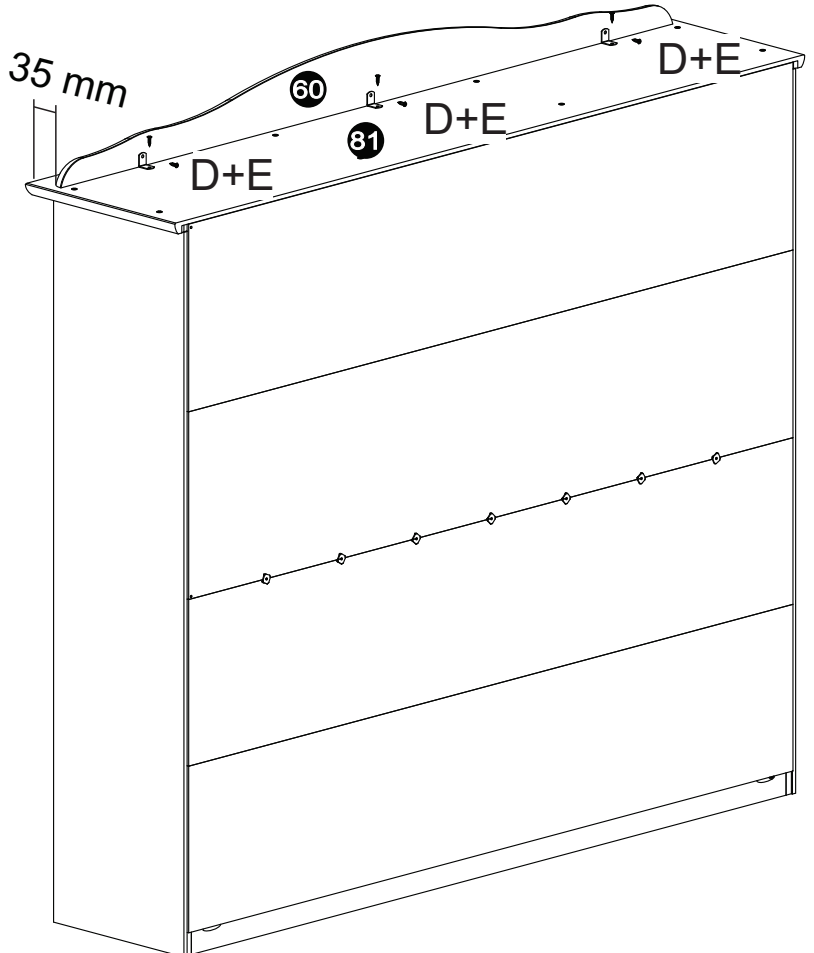
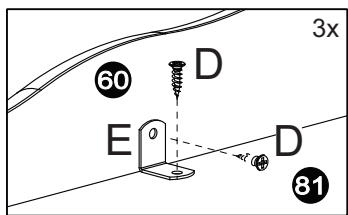
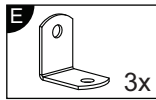
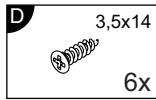

7

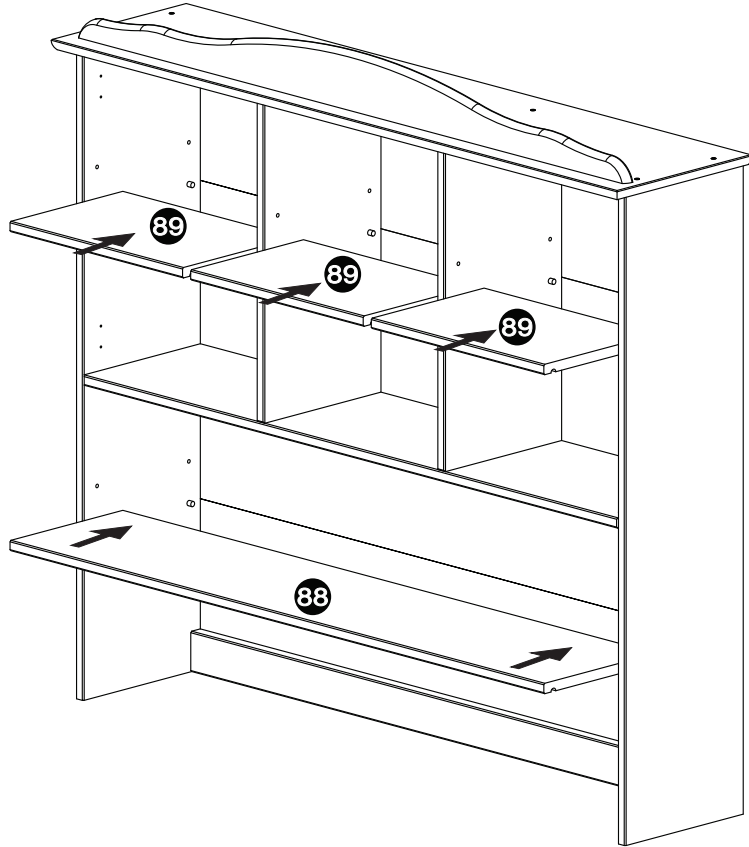

8

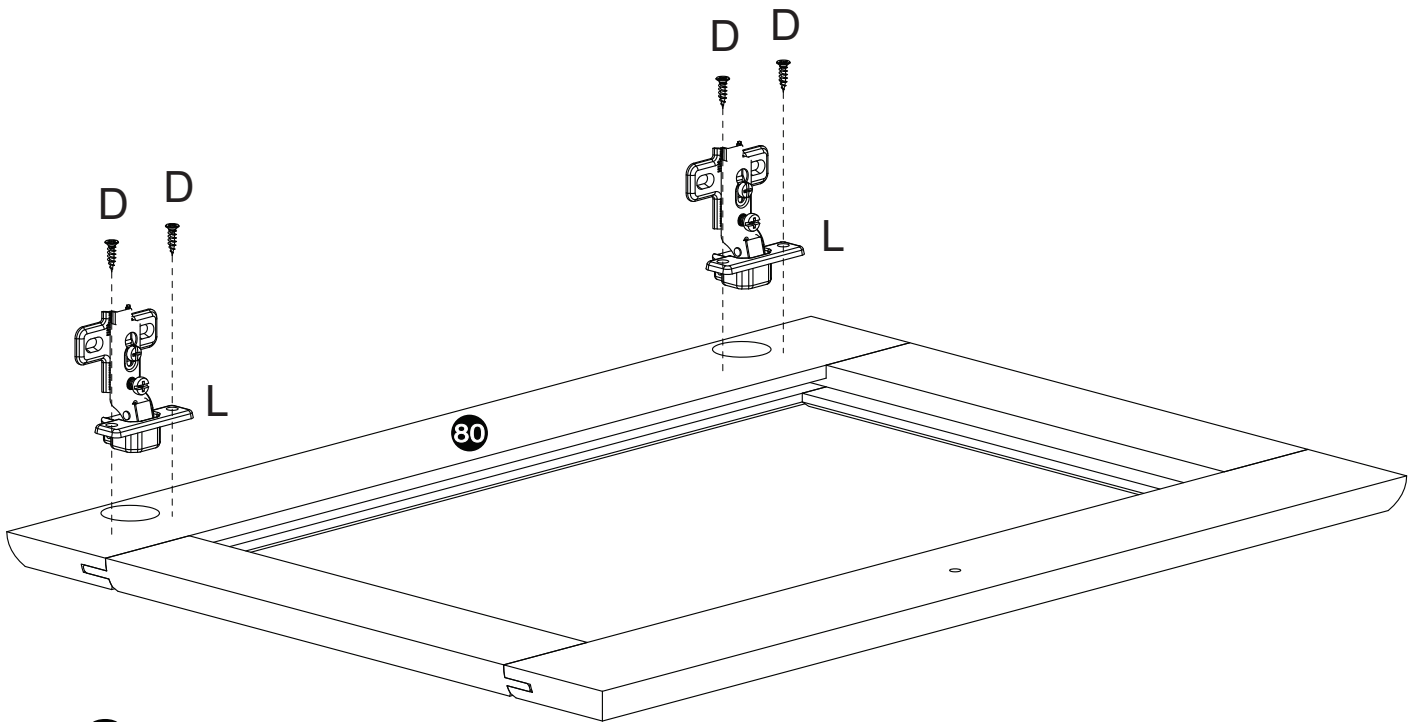
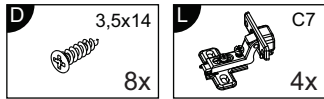

2x

9

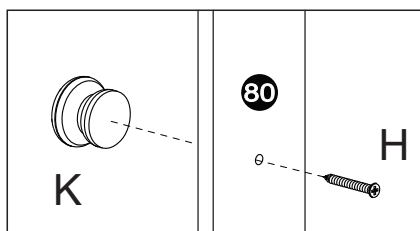
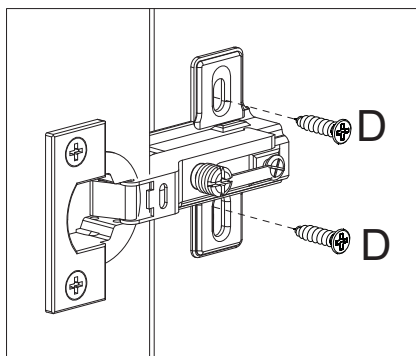
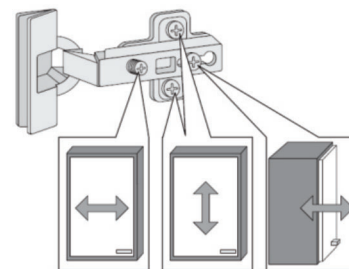
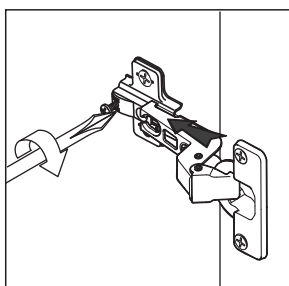
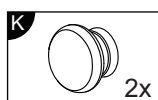
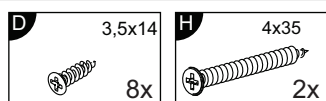

Türen einstellen (Scharniere justieren)
Adjusting the doors (adjusting the hinges)

Régler les portes (ajuster les charnières)

Sistemare le porte (regolare le cerniere)

Deuren instellen (scharnieren afstellen)

Nastawić drzwi (wyregulować zawiasy)

Vyrovnejte dvířka (seřid'te závěsy)

Nastavenie dverí (nastavenie závesov)

Állítsa be az ajtókat (állítsa be a zsanérokat)

Reglare ușii (ajustare balamale)

Kapıların ayarlanması (mentşelerin seviye ayarı)

Регулировка Дверей (регулировка шарнира)

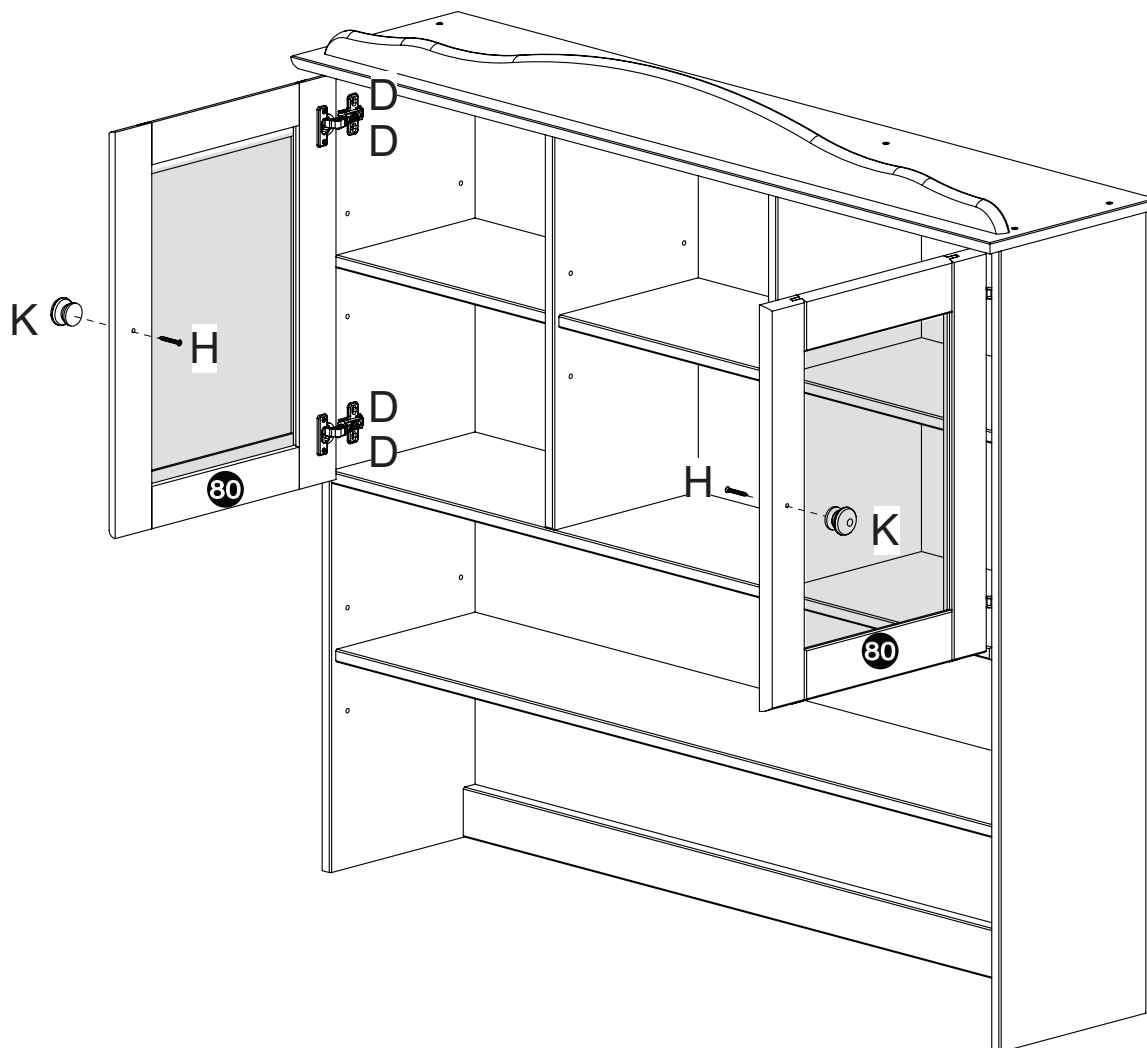

10

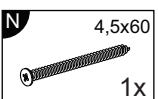
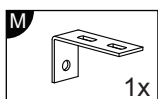
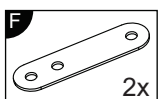
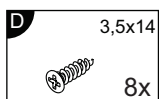

Achtung • Attention • Attenzione Opgelet • Uwaga • Pozor • Figyelem Atenție • Dikkat • Внимание	
(D)	Wandbefestigung dient als Kippschutz – unbedingt anbringen! Bei einigen Wandtypen kann ein Spezialdübel erforderlich sein!
(GB)	The wall fastening serves to prevent tipping – be absolutely sure to mount it! For certain wall types, a special wall plug may be necessary!
(FR)	La fixation murale sert de protection contre le basculement – à installer impérativement ! Pour certains types de murs il faut des chevilles spéciales !
(IT)	Il fissaggio alla parete serve da protezione anti-ribaltamento – attaccarla assolutamente! Per alcune strutture di parete può essere necessario un tassello speciale!
(NL)	Bevestiging aan de muur dient als kantelbescherming – zeker en vast bevestigen! Bij enkele muurtypes is een speciale plug misschien vereist!
(PL)	Mocowanie do ściany jest jednocześnie zabezpieczeniem przed przewróceniem – koniecznie zamontować! Do niektórych rodzajów ścian koniecznie zastosować specjalne kolki mocujące.
(CZ)	Montáž na stěnu slouží jako ochrana proti převrnutí – bezpodmínečně umístěte! U některých typů stěn může být zapotřebí speciální hmoždinka!
(SK)	Upevnenie na stenu slúži ako ochrana proti prevráteniu – bezpodmienečne použite! Pre niektoré druhy stien môže byť potrebná špeciálna hmoždinka!
(HU)	A terméket a falhoz kel rögzíténi, különben az felborulhat! Egyes faltípusoknál speciális tiplít kell használni!
(RO)	Sistemul de fixare la perete servește ca protecție la răsturnare – de montat obligatoriu! Pentru unele tipuri de pereți este posibil să fie necesar un diblu special!
(TR)	Duvardaki sabitleme, devrilmeye karşı bir emniyet tedbiridir ve mutlaka monte edilmelidir! Bazı duvar tiplerinde bunun için özel dübel gerekli olabilir!
(RU)	Обязательно установите крепление на стене во избежание опрокидывания! Для некоторых типов стен может потребоваться специальный дюбель!

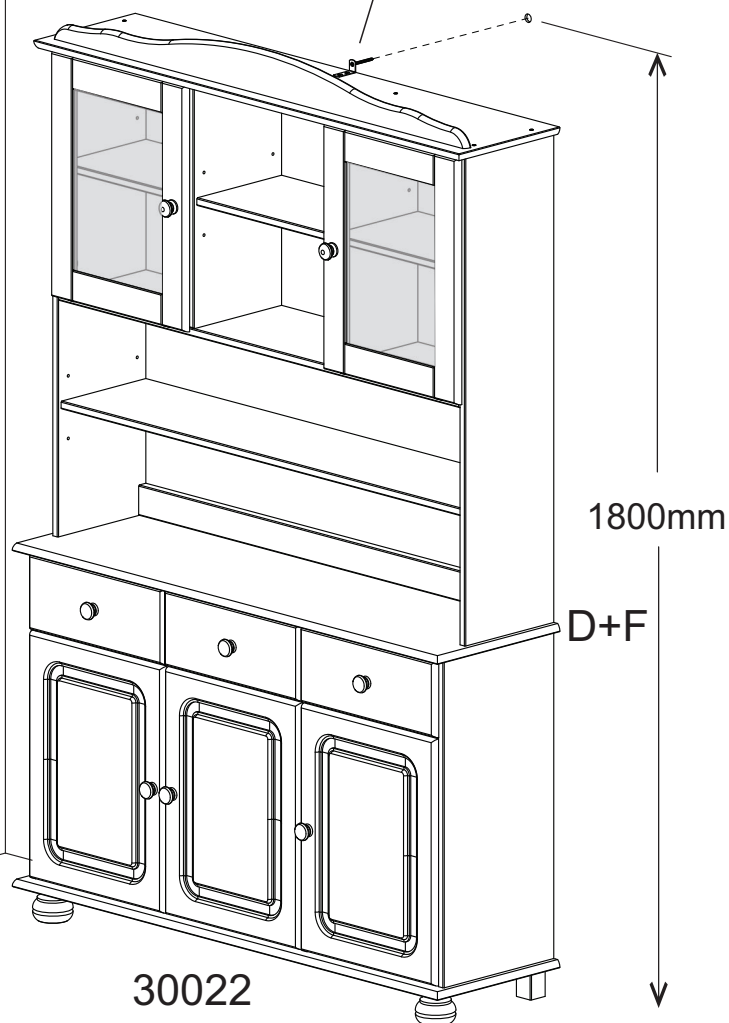
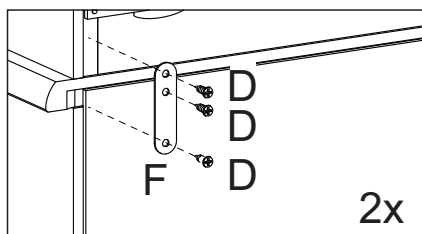
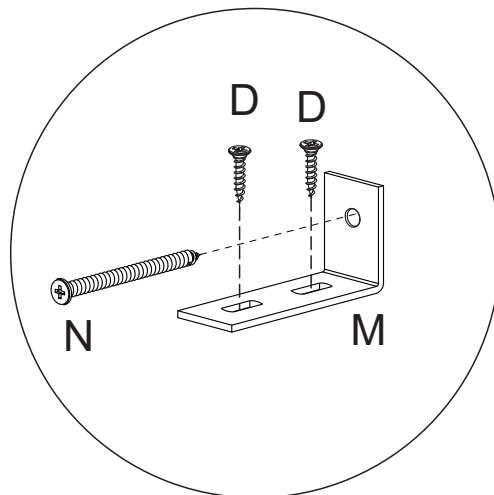

Mette 30022

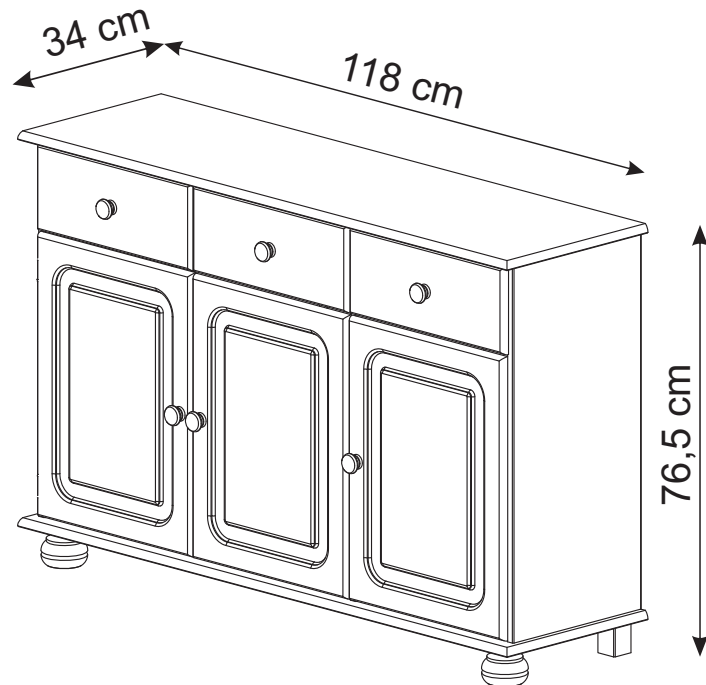

D Montageanleitung
30022

FR Notice de montage
30022

NL Handleiding voor de montage
30022

CZ Montážní návod
30022

HU Szerelési útmutató
30022

TR Montaj talimatı
30022

GB Assembly instructions
30022

IT Istruzioni di montaggio
30022

PL Instrukcja montażu
30022

SK Návod na montáž
30022

RO Instrucțiuni de montaj
30022

RU Инструкция по монтажу
30022

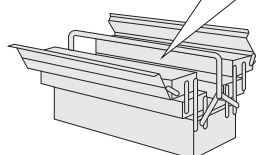
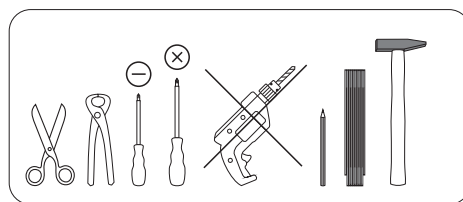
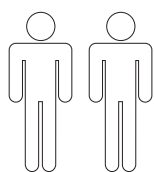

0
10
20
30
40
50
60
70
80
90
100
110
120
130
140
150
160
170
180
190
200

Service • Assistenza • Dienstverlening • Serwis Servis • Szerviz • Сервисная служба	
Name • Nom • Nome • Naam • Nazwa • Jméno • Názov • Név • Denumire • Isim • Название	
Nr. • No. • N° • Номер • Č • Sz	
Typ • Type • Tip • Típus • Tipo • Тип	

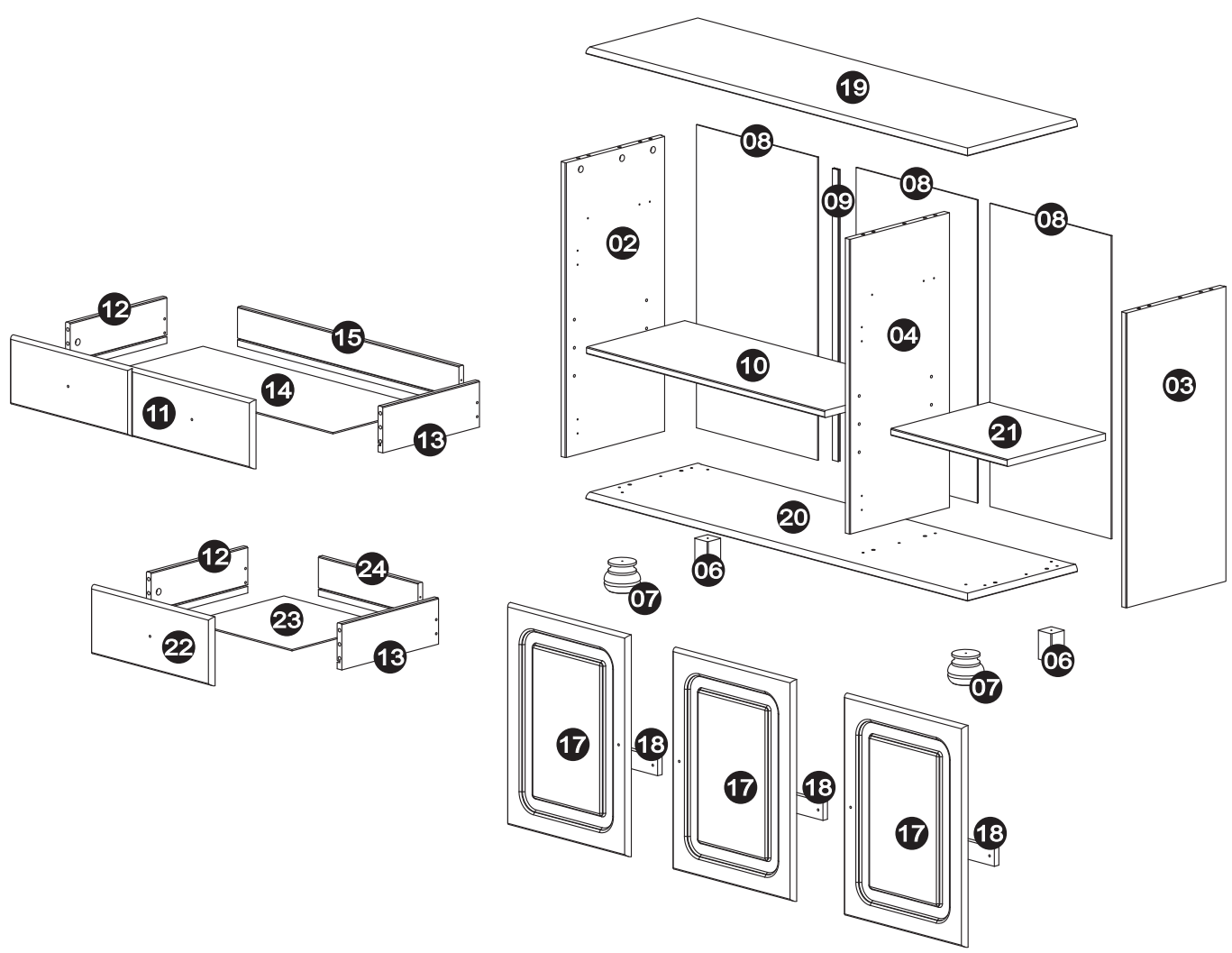

- | | | | | | | | | |
|-------------------------------|-------------------------------|--------------------|-------------------------------|---------------------------|---------------------------|------------------------------|-------------------------------|---------------------|
| A

8,0x30
20x | B

13x | C

8x | D

3,5x14
46x | E

300
2x | F

300
2x | G

13x | H

4,0x40
13x | I

36x |
| J

6x | K

3,5x30
14x | L

6x | M

4,0x25
9x | N

C7
6x | O

1x | P

4,5x60
1x | Q

3x | |

1

- A** 8,0x30 20x
- B** 13x
- C** 8x

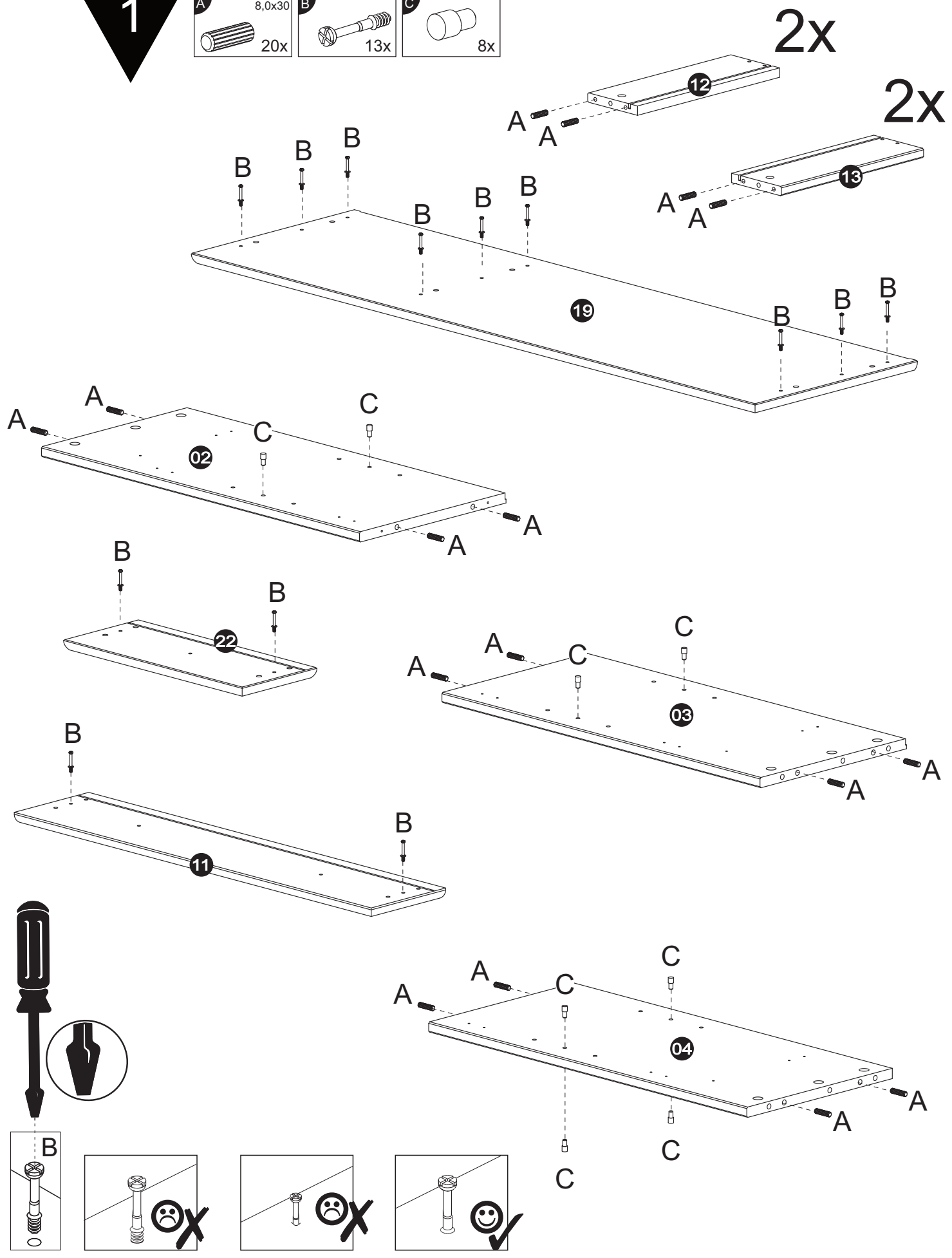

2

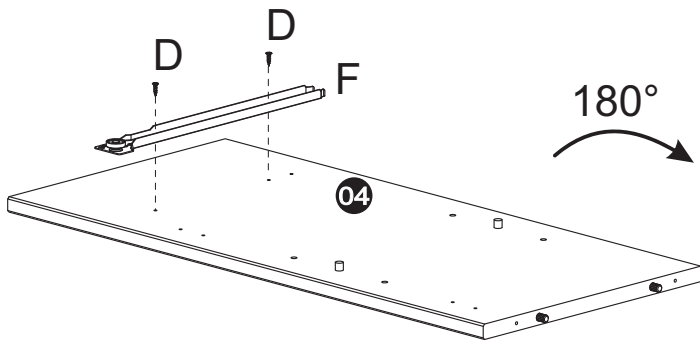
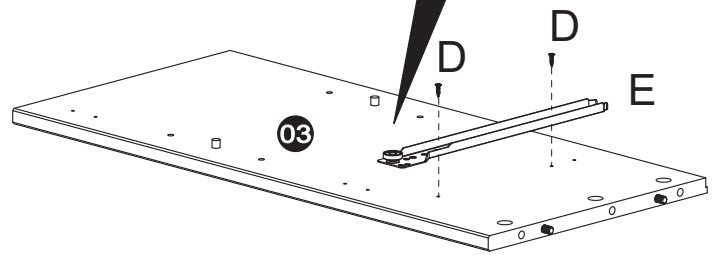
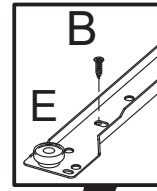
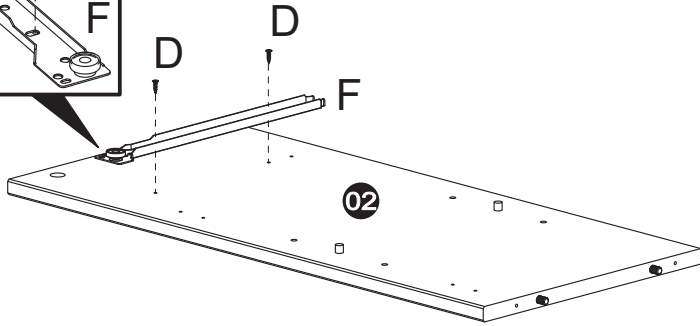
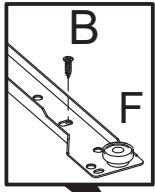
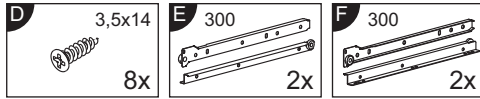

180°

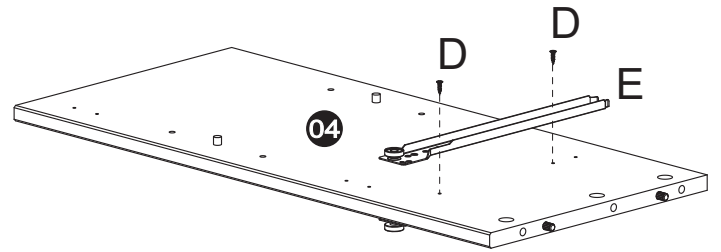

3

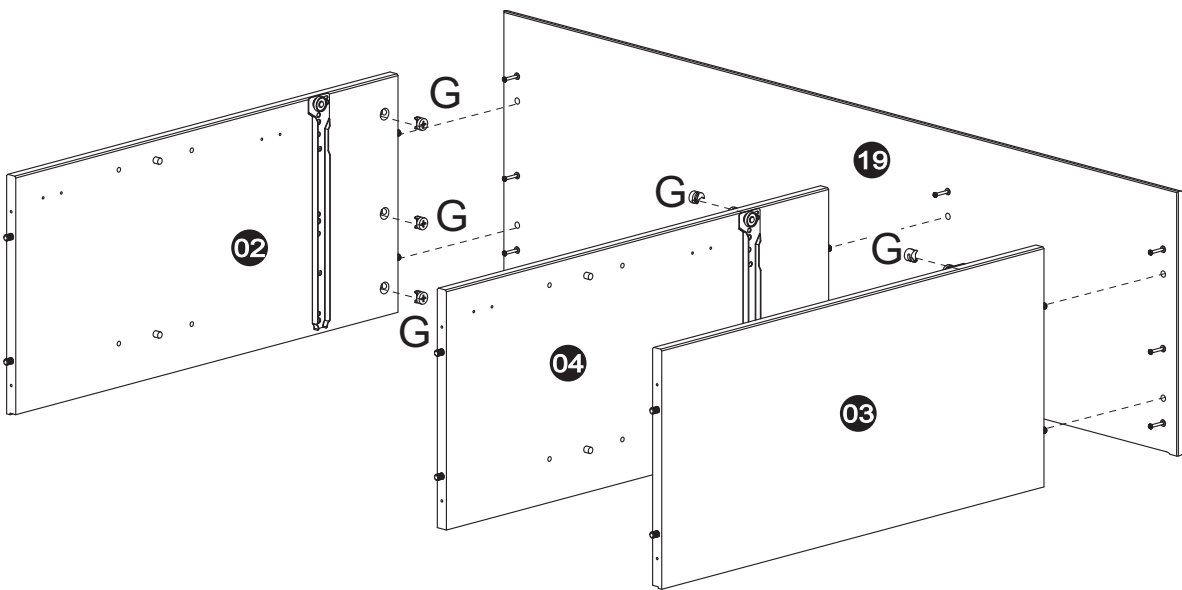
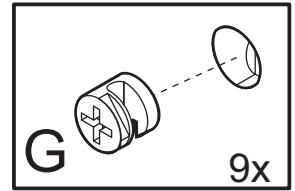
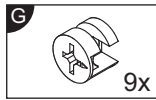

4

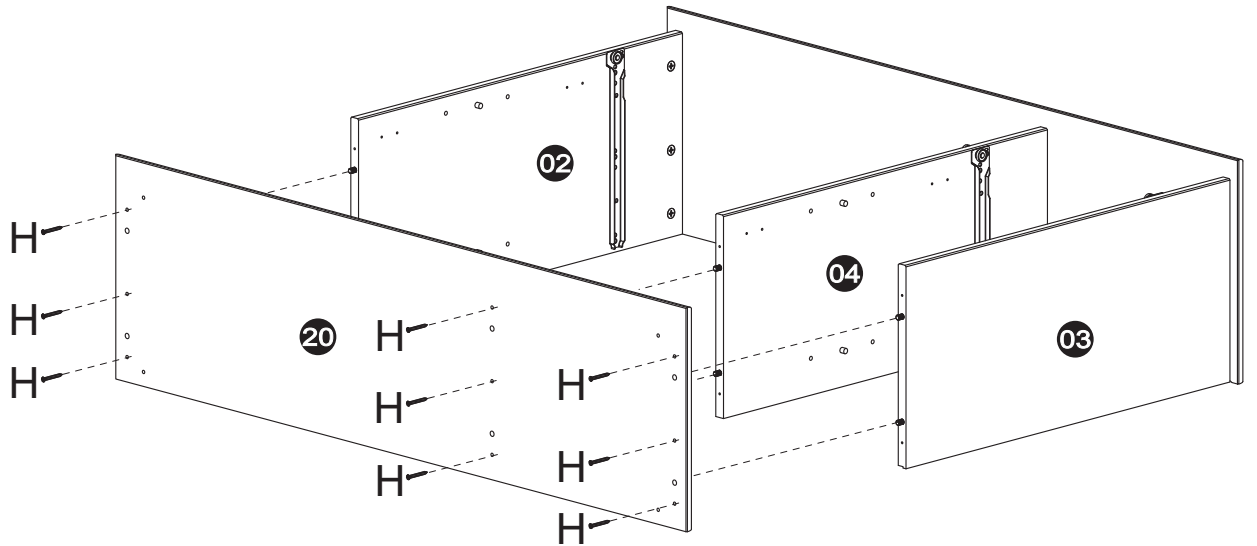
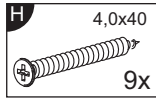

5

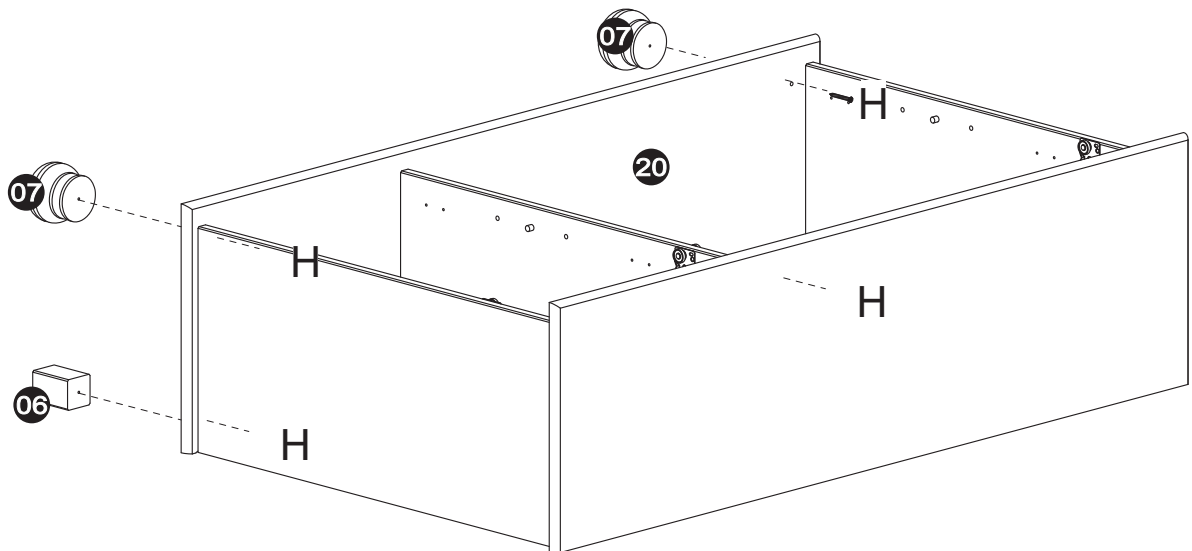
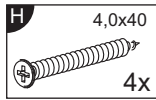

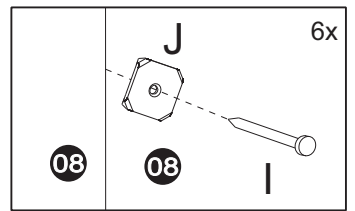
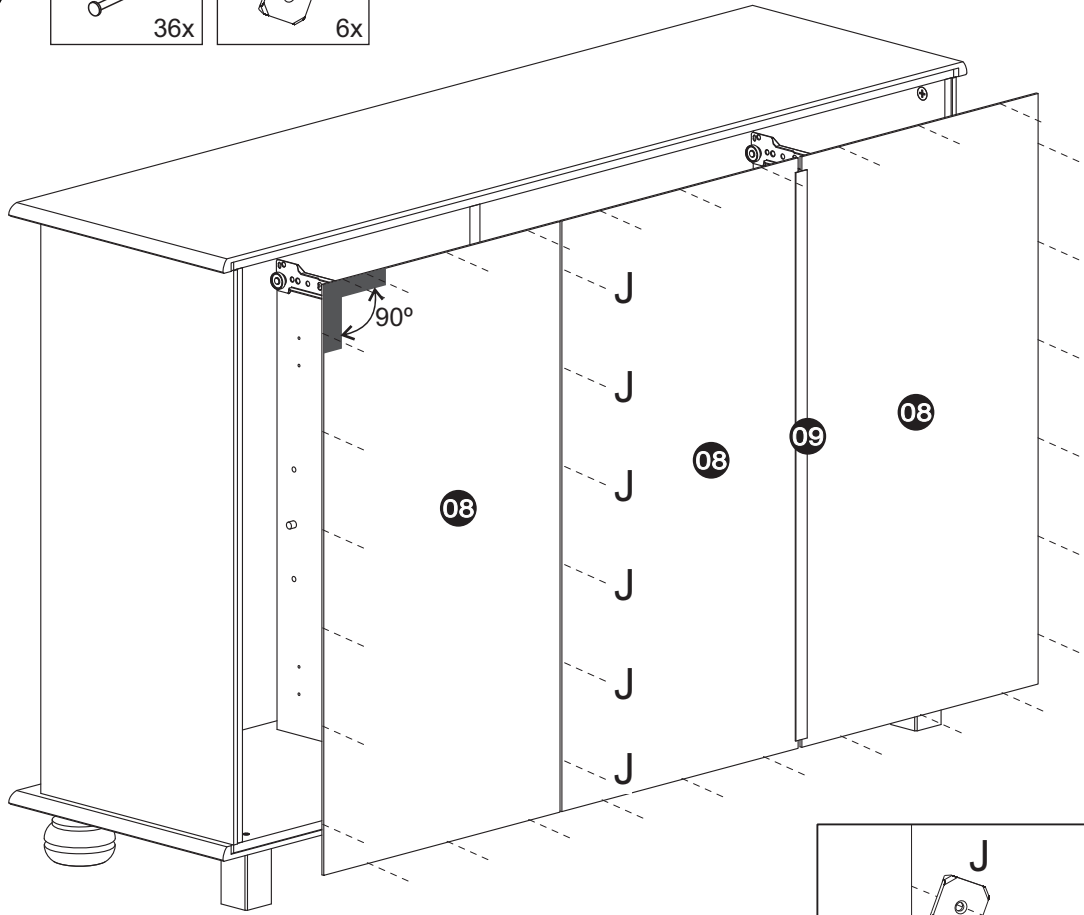
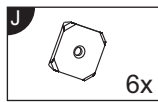
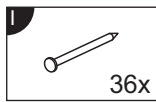

6

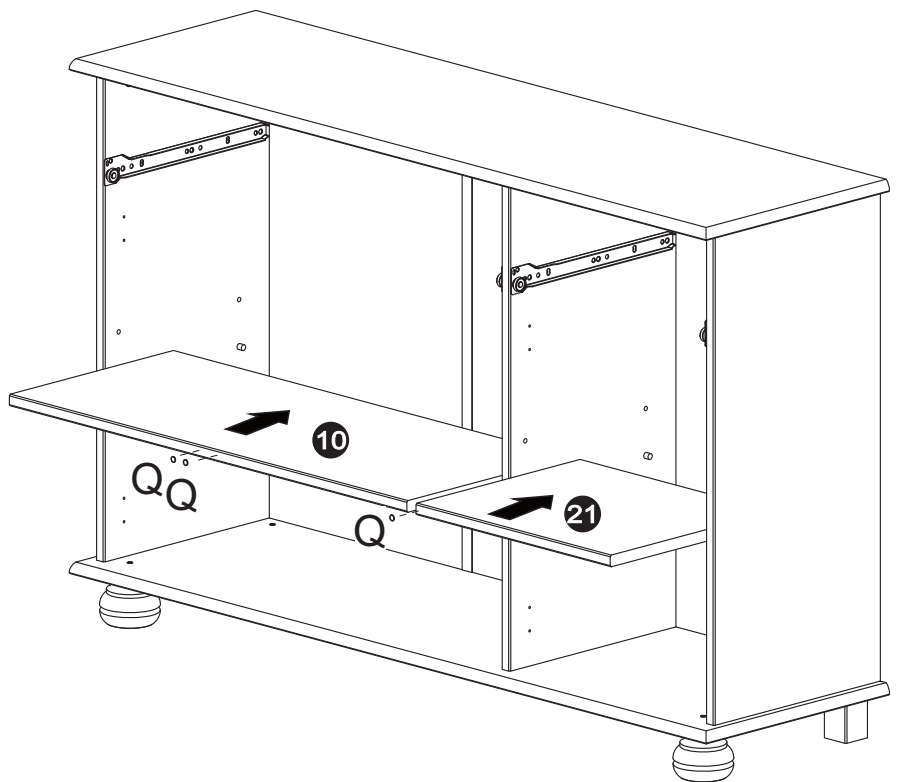
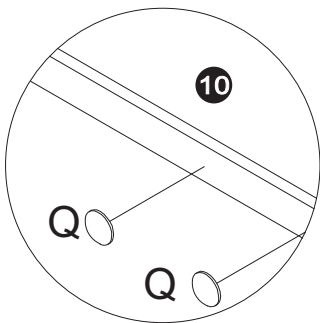

7

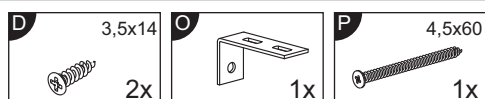



 Achtung • Attention • Attenzione Opgelet • Uwaga • Pozor • Figyelem Atenție • Dikkat • Внимание 	
(D)	Wandbefestigung dient als Kippschutz – unbedingt anbringen! Bei einigen Wandtypen kann ein Spezialdübel erforderlich sein!
(GB)	The wall fastening serves to prevent tipping – be absolutely sure to mount it! For certain wall types, a special wall plug may be necessary!
(FR)	La fixation murale sert de protection contre le basculement – à installer impérativement ! Pour certains types de murs il faut des chevilles spéciales !
(IT)	Il fissaggio alla parete serve da protezione anti-ribaltamento – attaccarla assolutamente! Per alcune strutture di parete può essere necessario un tassello speciale!
(NL)	Bevestiging aan de muur dient als kantelbescherming – zeker en vast bevestigen! Bij enkele muurtypes is een speciale plug misschien vereist!
(PL)	Mocowanie do ściany jest jednocześnie zabezpieczeniem przed przewróceniem – koniecznie zamontować! Do niektórych rodzajów ścian koniecznie zastosować specjalne kolki mocujące.
(CZ)	Montáž na stěnu slouží jako ochrana proti převrnutí – bezpodmínečně umístěte! U některých typů stěn může být zapotřebí speciální hmoždinka!
(SK)	Upevnenie na stenu slúži ako ochrana proti prevráteniu – bezpodmienečne použite! Pre niektoré druhy stien môže byť potrebná špeciálna hmoždinka!
(HU)	A termékét a falhoz kel rögzíteni, különben az felborulhat! Egyes faltípusoknál speciális tiplit kell használni!
(RO)	Sistemul de fixare la perete servește ca protecție la răsturnare – de montat obligatoriu! Pentru unele tipuri de pereți este posibil să fie necesar un diblu special!
(TR)	Duvardaki sabitleme, devrilmeye karşı bir emniyet tedbiridir ve mutlaka monte edilmelidir! Bazı duvar tiplerinde bunun için özel bir dübel gerekli olabilir!
(RU)	Обязательно установите крепление на стене во избежание опрокидывания! Для некоторых типов стен может потребоваться специальный дюбель!

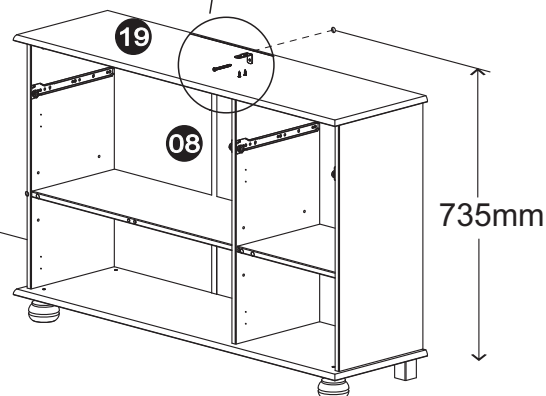
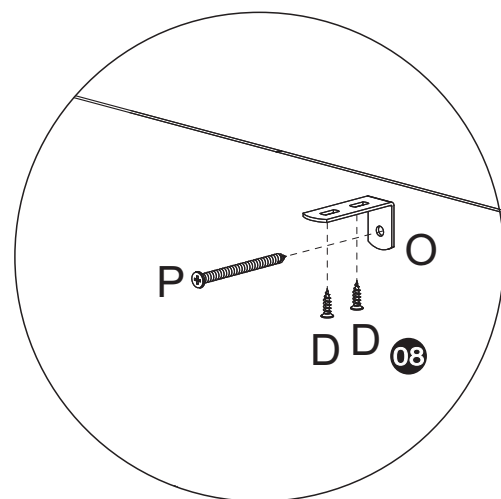

9

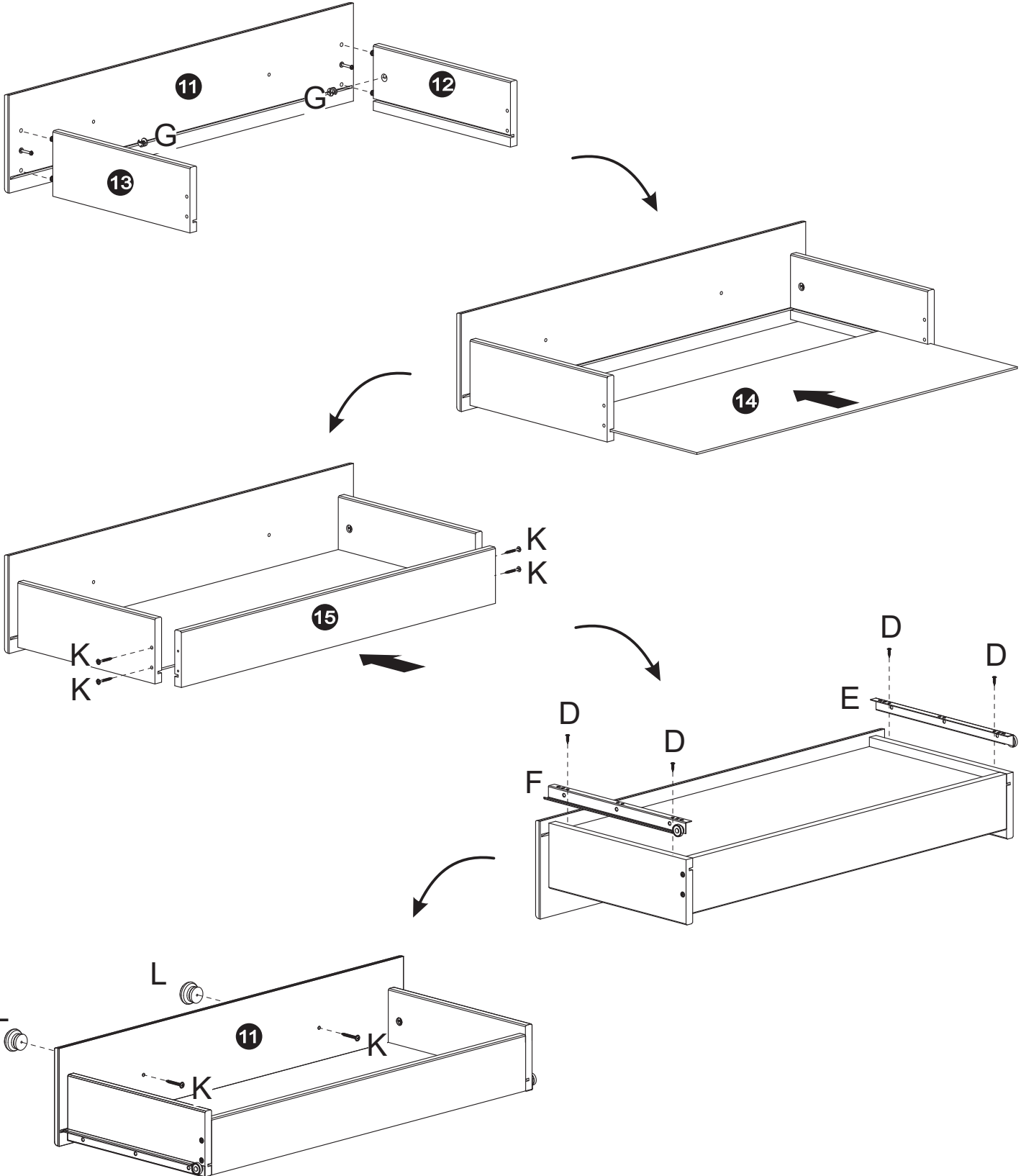
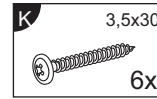
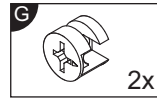
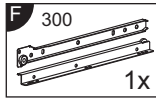
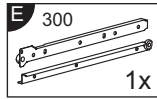
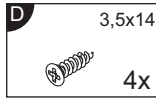

10

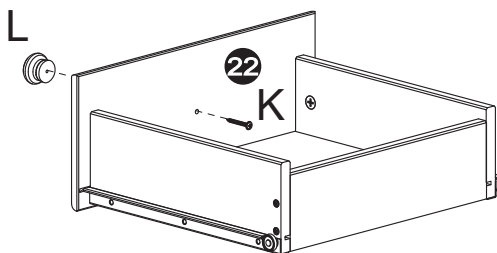
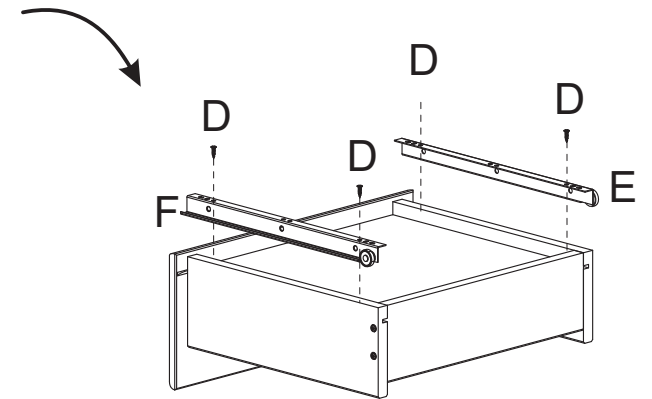
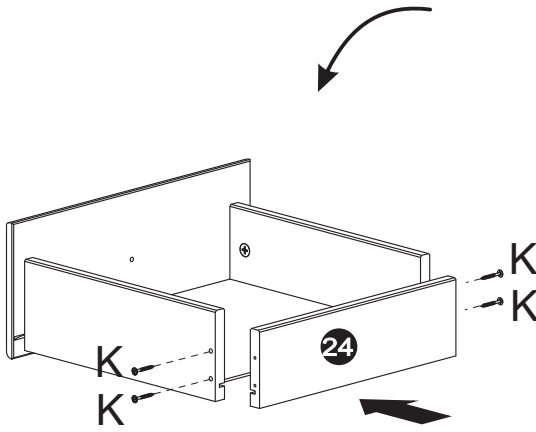
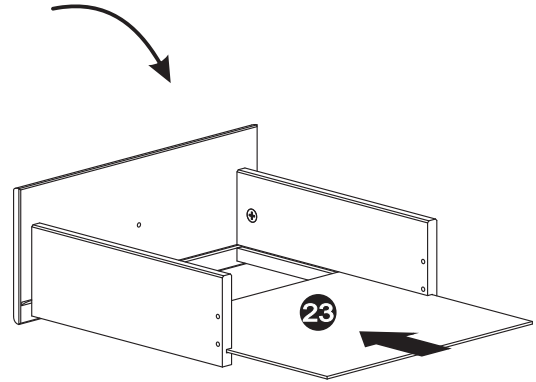
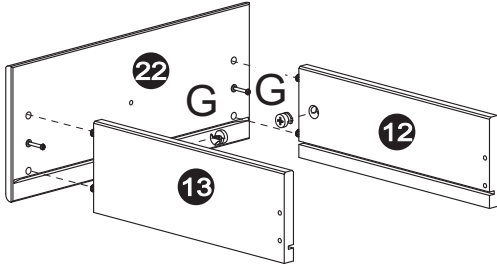
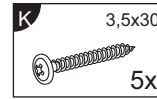
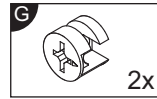
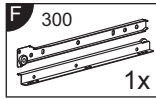
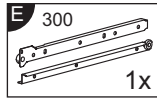
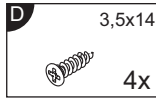

11

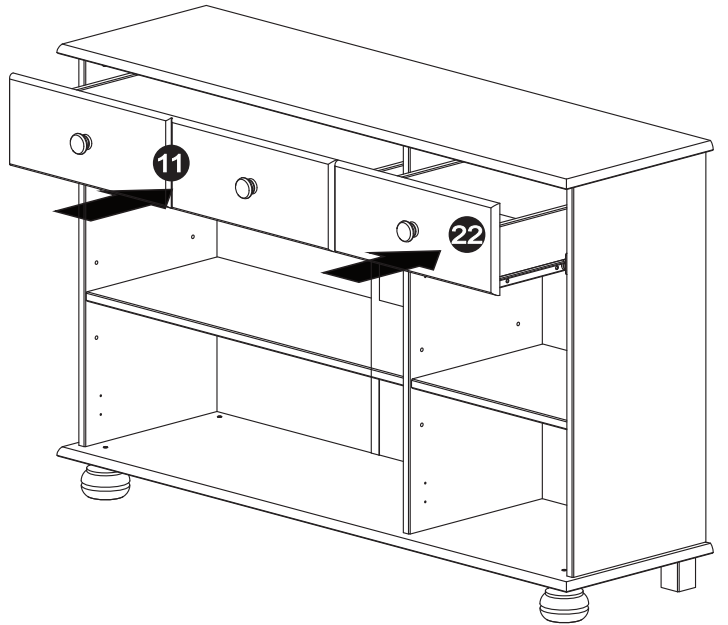
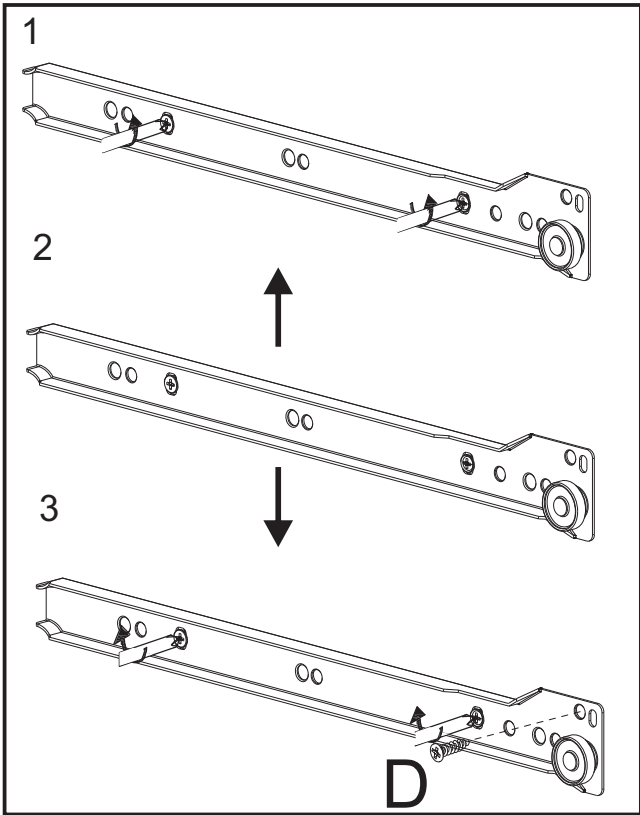
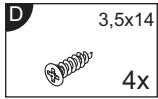

12

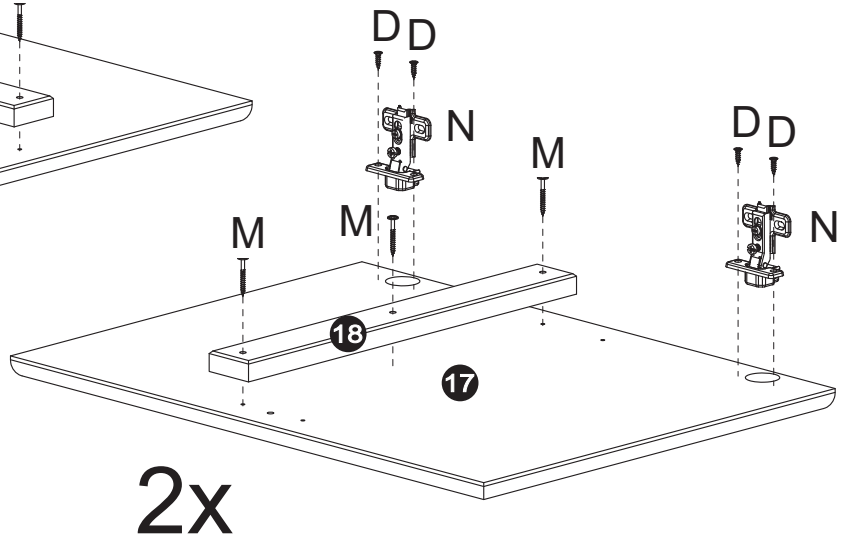
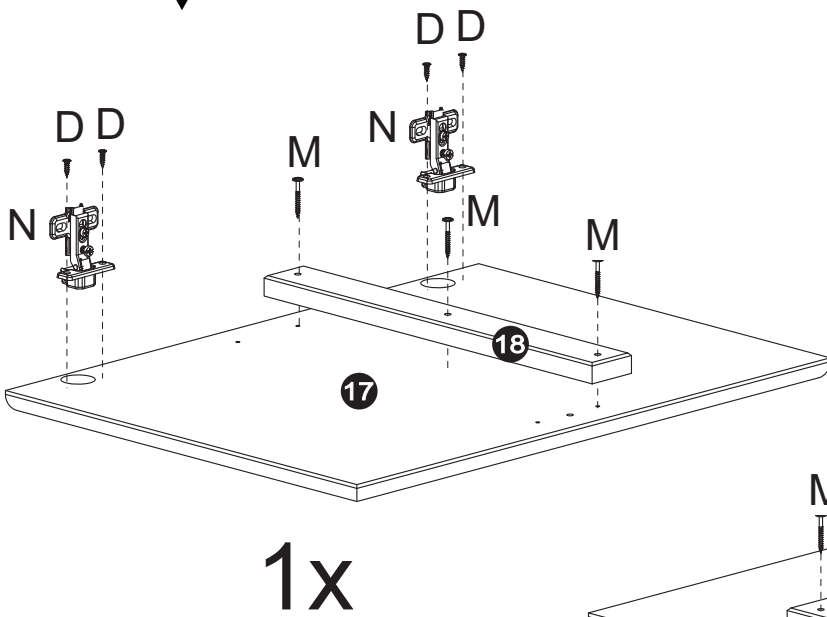
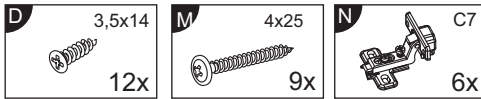

13

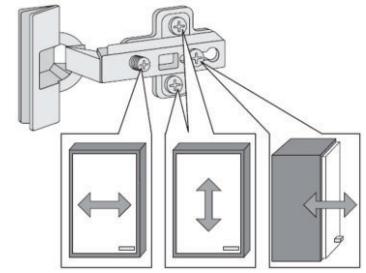
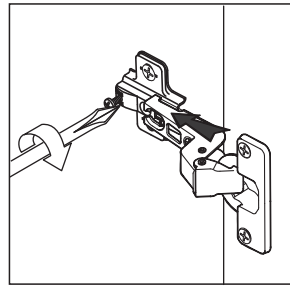
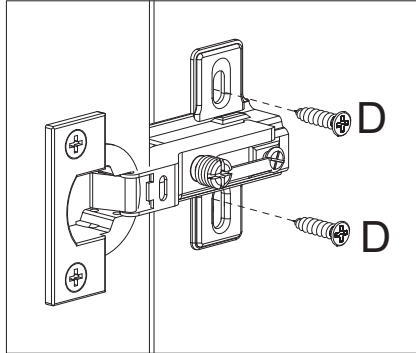
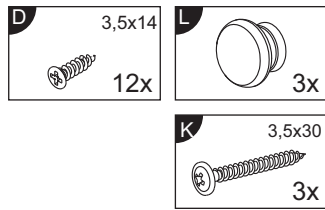

Türen einstellen (Scharniere justieren)
 Adjusting the doors (adjusting the hinges)
 Régler les portes (ajuster les charnières)
 Sistemare le porte (regolare le cerniere)
 Deuren instellen (scharnieren afstellen)
 Nastawić drzwi (wyregulować zawiasy)
 Vyrovnajte dvířka (seřid'te závěsy)
 Nastavenie dverí (nastavenie závesov)
 Állítsa be az ajtókat (állítsa be a zsanérokat)
 Reglare ușii (ajustare balamale)
 Kapıların ayarlanması (menteşelerin seviye ayarı)
 Регулировка Дверей (регулировка шарнира)

