

BAUANLEITUNG

Artikel Nummer: WF317871

WF317872

Polsterbett 90*200

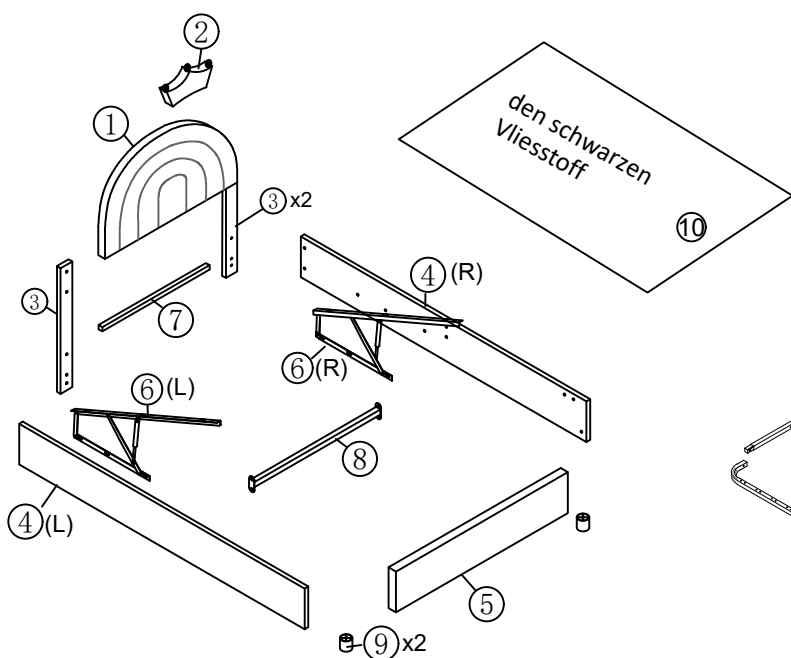
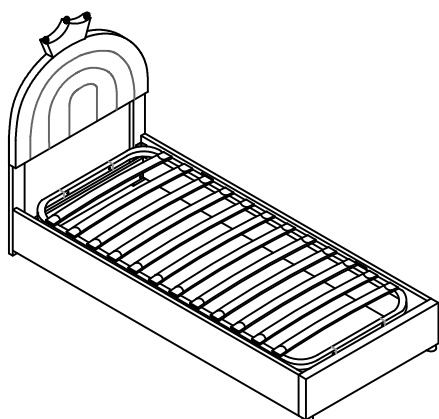

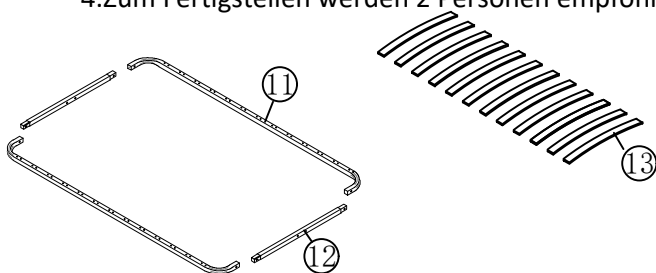

TIPPS

1. Dieses Set besteht aus 2 Kartons. Sollten Sie nicht alle 2 Kartons erhalten, wenden Sie sich bitte an unseren Kundenservice.
2. Bitte lesen Sie die Anweisungen vor der Montage vollständig durch. Diese Anleitung enthält wichtige Informationen, die eine korrekte Montage gewährleisten können. Wir haben daran gearbeitet, qualitativ hochwertige Produkte für Sie bereitzustellen. Sollte Ihr Produkt jedoch in seltenen Fällen defekt sein, Teile fehlen oder es Probleme gibt, zögern Sie bitte nicht, unseren Kundenservice zu kontaktieren, um Teileanforderungen, Montagevorschläge oder Garantieansprüche einzureichen. Wir werden Ihnen dann die beste Lösung anbieten schnellstmöglich. Bei Bedarf benötigen wir von Ihnen einige klarere Bilder des Problems.
3. Setzen Sie die Schrauben in die Löcher ein und ziehen Sie die Schrauben fest, aber nicht zu fest, 70 % bis 80 % sind in Ordnung, ziehen Sie schließlich alle Schrauben fest. Wenn Probleme auftreten, weil einige Schrauben nicht in das Loch passen oder einige Teile schwer zu installieren sind, passen Sie bitte den festen Sitz der Schrauben an.
4. Zum Fertigstellen werden 2 Personen empfohlen.





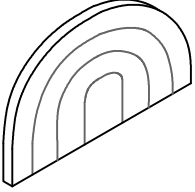

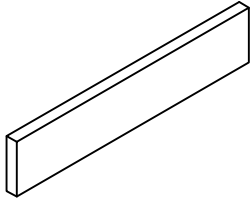
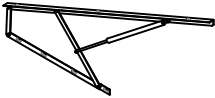
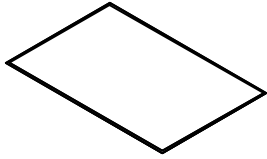
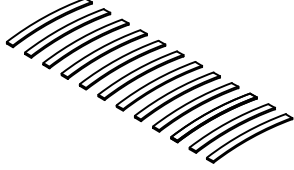

| Liste der Einzelteile | | | Hardware List | | |
|-----------------------|---------------------------|-----|---------------|---|-----|
| NO | ITEM | QTY | NO | ITEM | QTY |
| 1 | Kopfteil | 1 | A | Inbusschlüssel  | 1 |
| 2 | Krone | 1 | B | Schrauben (M8x45mm)  | 14 |
| 3 | Beine des Kopfteils | 2 | C | Scharnier  | 2 |
| 4 | Seitenschienen | 2 | D | Schrauben (M8x18mm)  | 40 |
| 5 | Fußbrett | 1 | E | Kleine "7"-Verbindungssecke  | 2 |
| 6 | Gaslift | 2 | F | Metallecke  | 2 |
| 7 | Querstange für Kopfteil | 1 | G | Nägeln (M4x50mm)  | 2 |
| 8 | Querstange | 1 | I | Nüsse  | 2 |
| 9 | Bettbeine | 2 | J | Halterung aus  | 1 |
| 10 | Vliesstoff | 1 | K | Nüsse  | 10 |
| 11 | Metallrahmen Seitenstange | 2 | L | Vier-Loch-Eisen  | 1 |
| 12 | Metallrahmen Querstange | 2 | M | Drei-Loch-Eisen  | 2 |
| 13 | Lattenroste | 12 | N | Stopper  | 1 |
| | | | O | Endleistenkappe  | 24 |

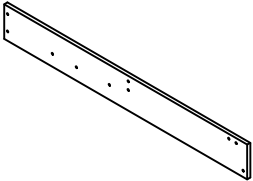
Teileliste Hardware-Liste WF 317871

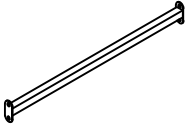
| | | |
|--|--|--|
| <p>①</p>  <p>Kopfteil -1Stück</p> | <p>②</p>  <p>Krone -1Stück</p> | <p>⑤</p>  <p>Fußbrett -1Stück</p> |
| <p>⑥</p>  <p>Gaslift -2Stück</p> | <p>⑩</p>  <p>Vliesstoff -1Stück</p> | <p>⑬</p>  <p>Lattenroste -12Stück</p> |

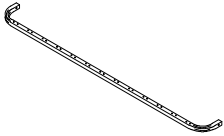
WF 317872



| | | |
|---|--|---|
| <p>③</p>  <p>Beine des Kopfteils -2Stück</p> | <p>④</p>  <p>Seitenschienen -2Stück</p> | <p>⑦</p>  <p>Querstange für Kopfteil -1Stück</p> |
| <p>⑧</p>  <p>Querstange -1Stück</p> | <p>⑨</p>  <p>Bettbeine -2Stück</p> | <p>⑪</p>  <p>Metallrahmen Seitenstange -2Stück</p> |
| <p>⑫</p>  <p>Metallrahmen Querstange -2Stück</p> | | |

Achtung: Ziehen Sie die Schrauben nicht fest, bevor Sie die gesamte Installation abgeschlossen haben. Wenn Sie Schwierigkeiten mit der Installation haben, zögern Sie bitte nicht, uns zu kontaktieren.

Step 1

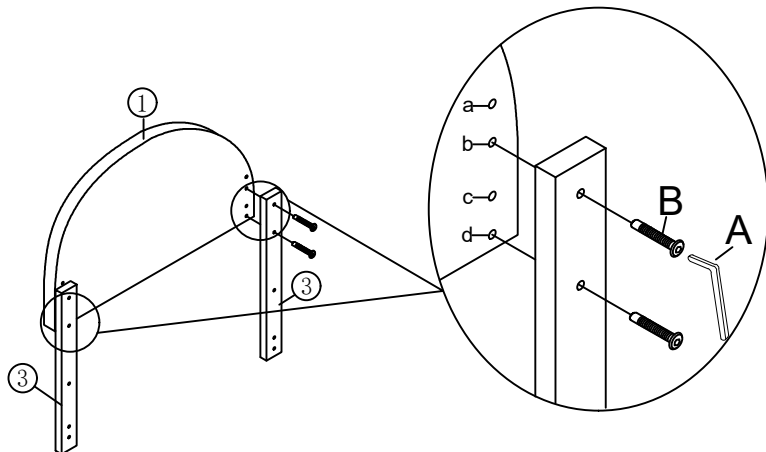
Befestigen Sie die Kopfteilbeine ③ mit den Schrauben B und dem Inbusschlüssel A am Kopfteil ①. Sie können die Löcher a und c oder b und d wählen.





| | |
|---|--|
| A Kopfteil  | B Krone x 4  M8X45mm |
|---|--|

Step 2

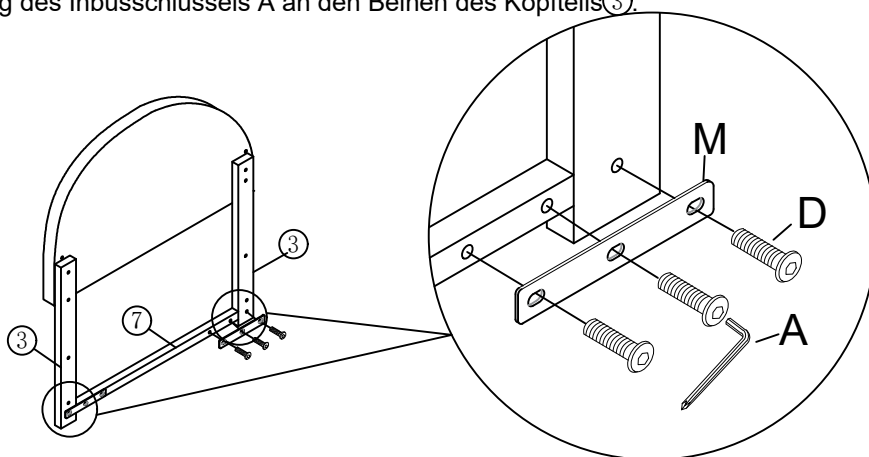
Befestigen Sie die Querstange ⑦ des Kopfteils mit den Schrauben D und dem Dreiloch Eisen M unter Verwendung des Inbusschlüssels A an den Beinen des Kopfteils ③.





| | | |
|--|--|--|
| A Kopfteil  | M Drei-Loch-Eisen x2  | D Schrauben x 6  M8X18mm |
|--|--|--|

Step 3

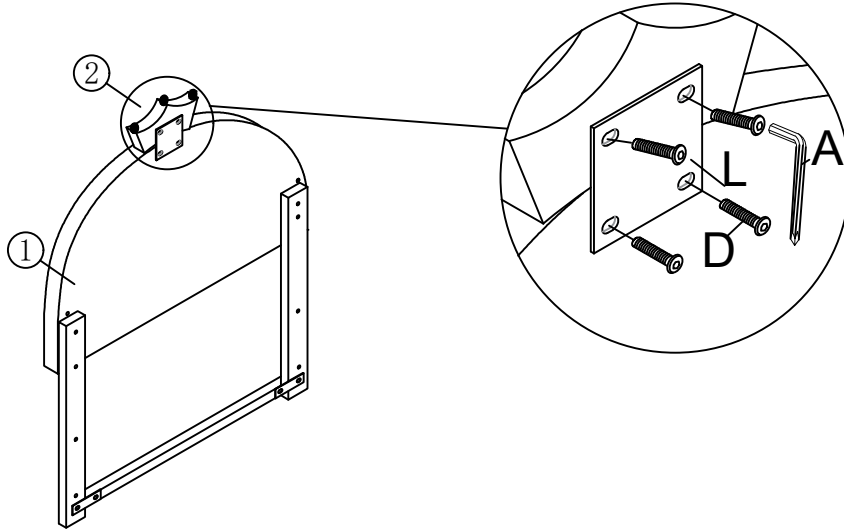
Befestigen Sie die Krone ② mit den Schrauben L und dem Vierlocheisen unter Verwendung des Inbusschlüssels A am Kopfteil ①.





| | | |
|--|--|--|
| A Kopfteil  | D Schrauben x 4  M8X18mm | L Vier-Loch-Eisen x 1  |
|--|--|--|

Step 4

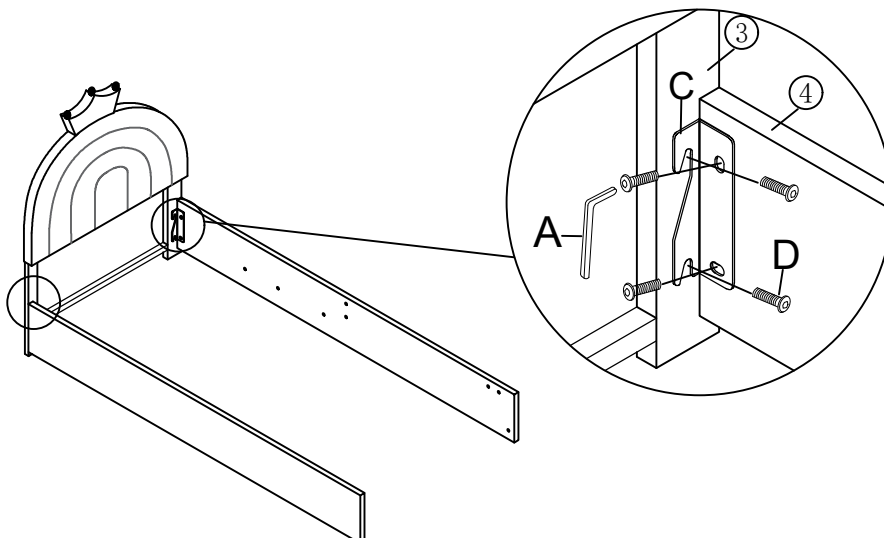
Befestigen Sie die Seitenschienen ④ mit den Schrauben D und den Scharnieren C unter Verwendung des Inbusschlüssels A an den Beinen ③ des Seitenkopfteils.





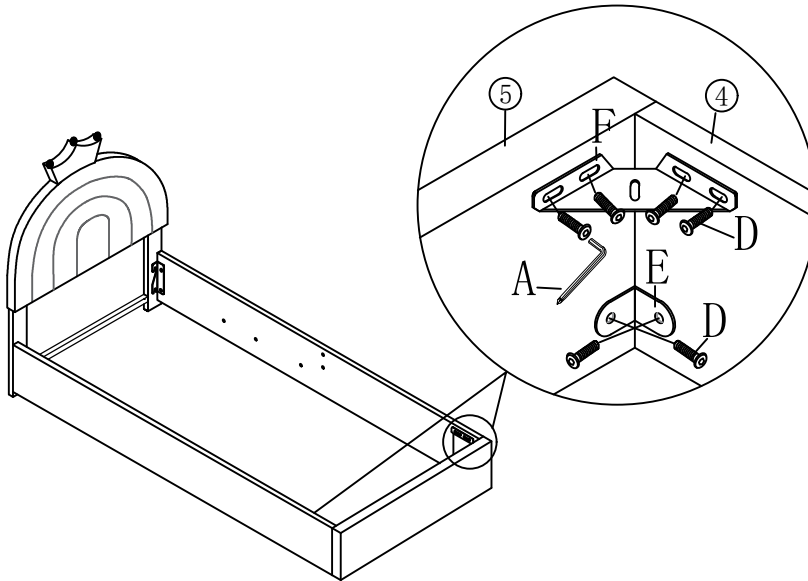

| | | |
|---|--|--|
| A Kopfteil  | C Scharnier x 2  | D Schrauben x 8  M8X18mm |
|---|--|--|

Step 5

Befestigen Sie die Seitenschienen ④ mit der Metallecke F, dem kleinen "7"-Verbindungsstück E und den Schrauben D mit dem Inbusschlüssel A am Trittbrett ⑤.





| | | | |
|---|--|---|---|
| <p>A Kopfteil</p>  | <p>D Schrauben x 12</p>  M8X18mm | <p>E Kleine "7"- Verbindungsstücke x2</p>  | <p>F Metallecke x 2</p>  |
|---|--|---|---|

Step 6

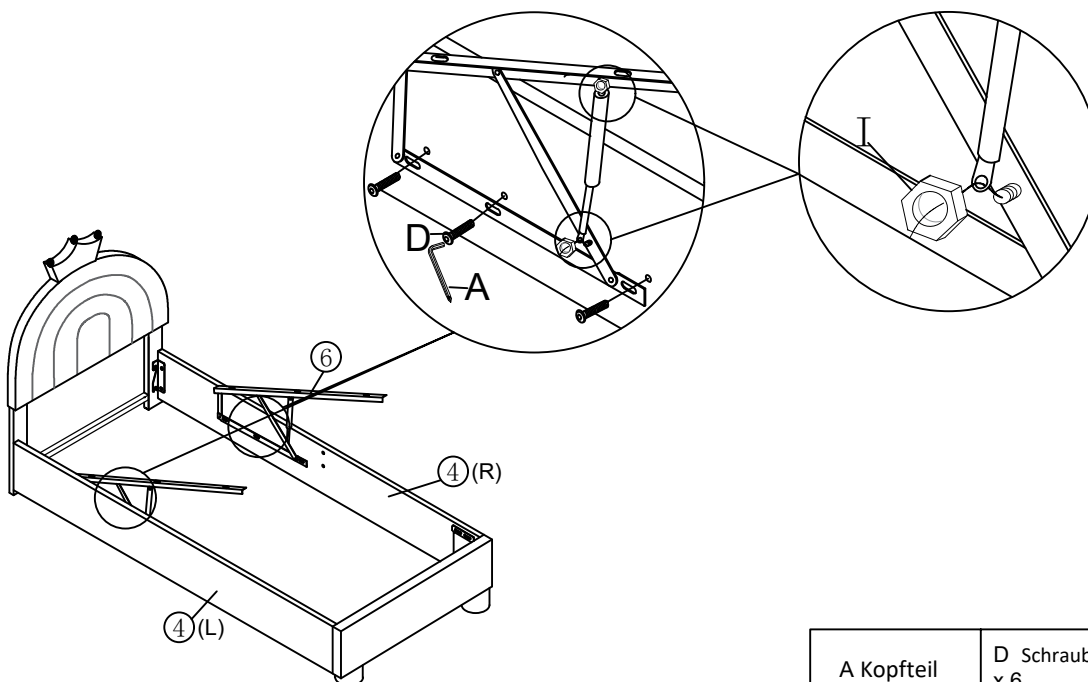
Befestigen Sie die Gasdruckfedern ⑥ an den Seitenplatte ④ mit den Schrauben D, indem Sie den Inbusschlüssel A oder eine elektrische Bohrmaschine verwenden. Befestigen Sie die Gasstange mit den Mutter I an den Gasdruckfedern ⑥.



| | | |
|---|---|--|
| <p>A Kopfteil</p>  | <p>D Schrauben x 6</p>  M8X18mm | <p>I Nüsse x 4</p>  |
|---|---|--|

Step 7

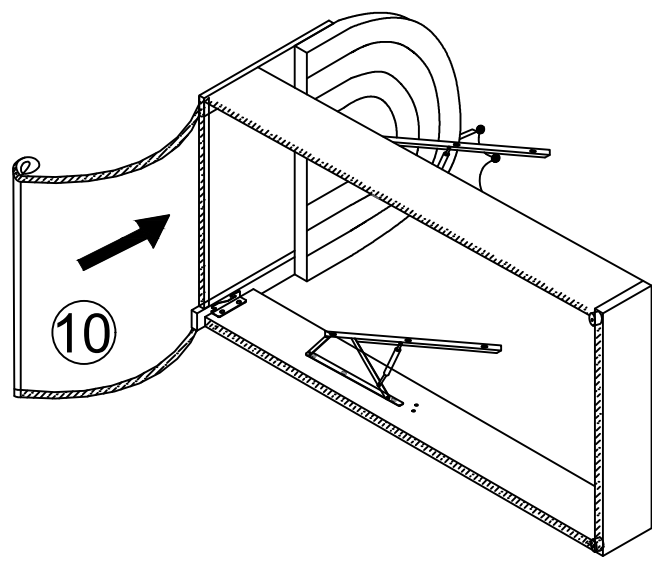

Kleben Sie den schwarzen Vliesstoff ⑩ auf den Boden des Bettes.

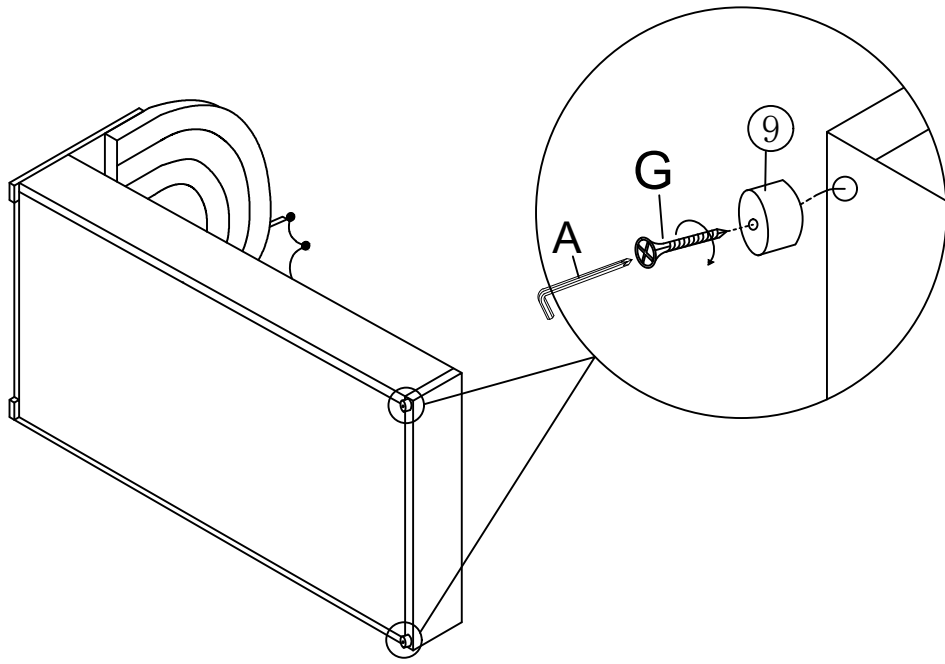

Step 8

Befestigen Sie die Beine ⑨ mit Nägeln G am Trittbrett ⑤ mit Elektrobohrer oder Schraubendreher.





| | |
|---|---|
| A Kopfteil  | G Nägel x 2  M4X50mm |
|---|---|

Step 9

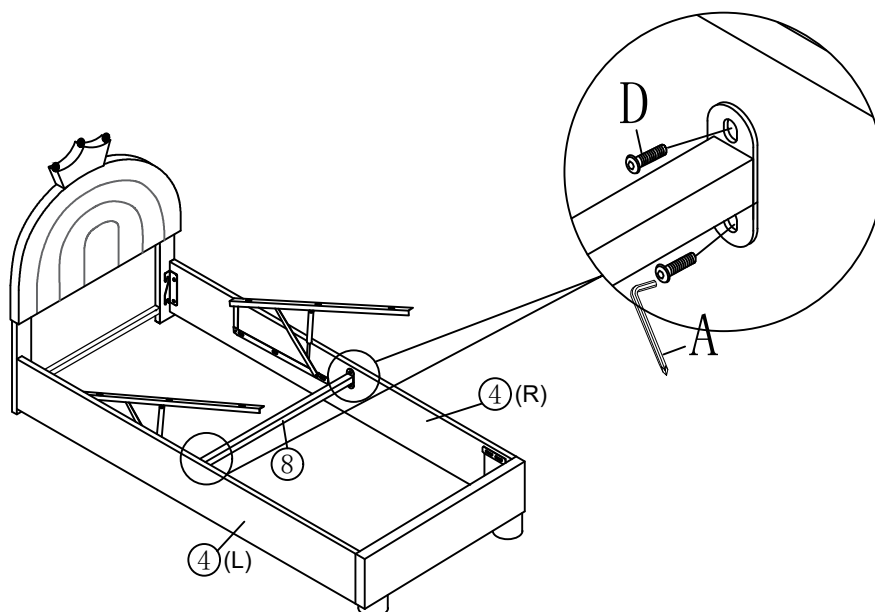
Befestigen Sie die Querstange ⑧ mit den Schrauben D und dem Inbusschlüssel A an den Seitenschienen ④.





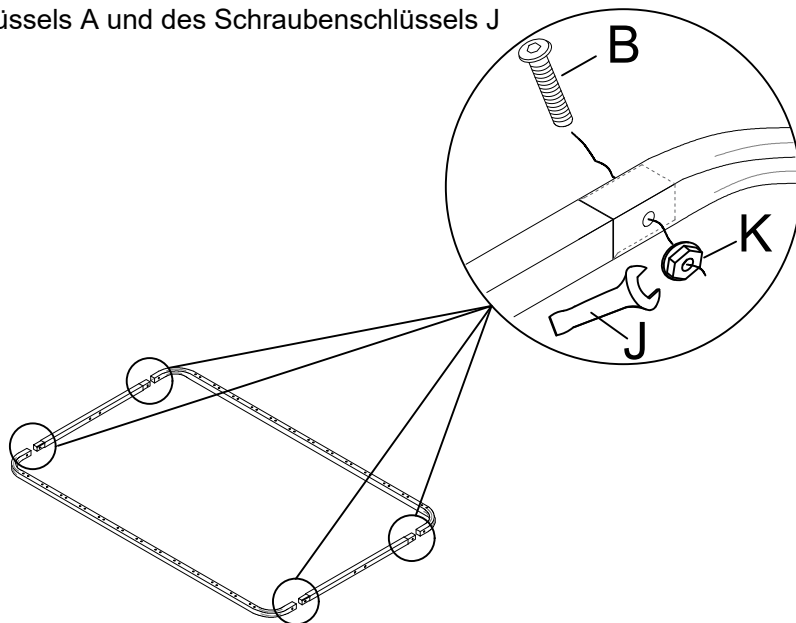

| | |
|---|--|
| <p>A Kopfteil</p>  | <p>D Schrauben x 4</p>  <p>M8X18mm</p> |
|---|--|

Step 10

Montieren Sie den Lamellenrahmen mit den Schrauben B und Muttern K unter Verwendung des Inbusschlüssels A und des Schraubenschlüssels J



| | | | |
|---|---|--|--|
| <p>A Kopfteil</p>  | <p>B Krone x 4</p>  <p>M8X45mm</p> | <p>K Nüsse x 4</p>  | <p>J Halterung aus x 1</p>  |
|---|---|--|--|

Step 11

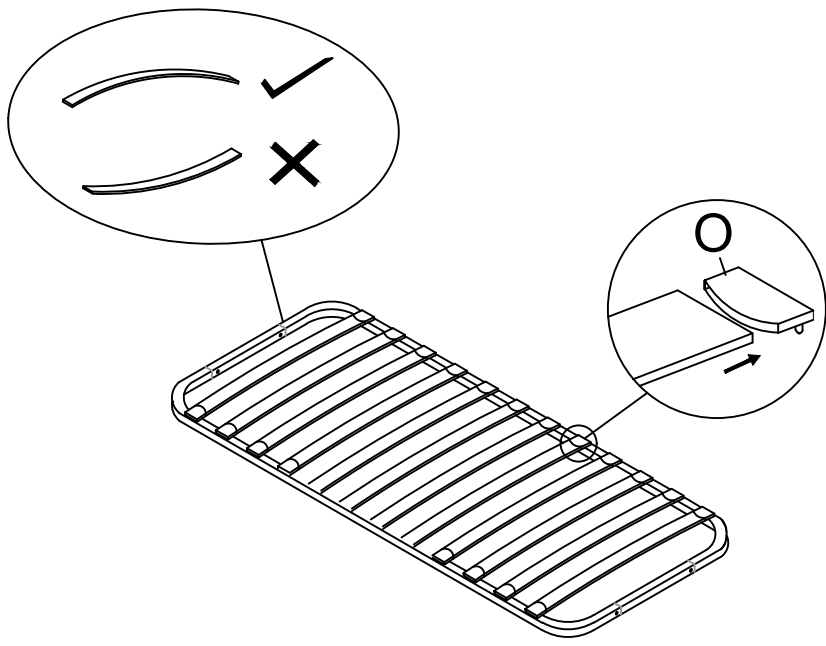

Montage der Lamellen in den montierten Lamellenrahmen mit Mittellamellenkappe N und Endlamellenkappe O.

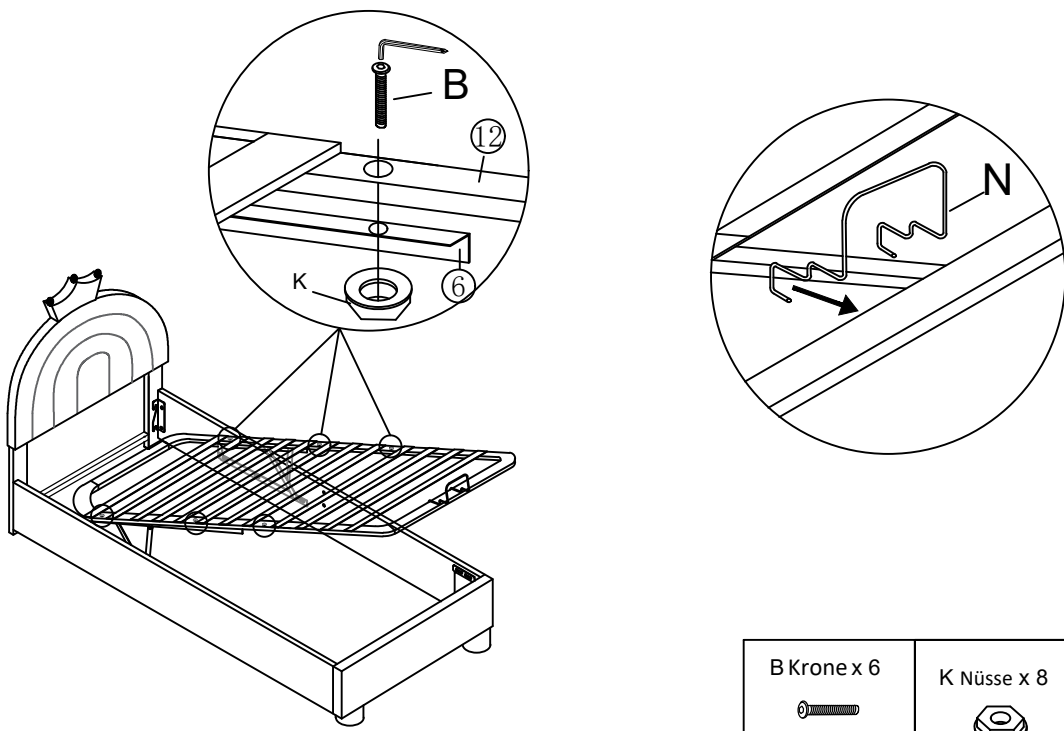

Step 12

Befestigen Sie den Lattenrahmen 11 mit den Schrauben B und Muttern K an den Gasfedern 6, setzen Sie den Stopper N am Ende des Lattenrahmens ein, dann ist der Zusammenbau abgeschlossen. Jetzt ziehen Sie bitte alle Beschläge fest und genießen Sie Ihr Bett



| | | |
|--|--|--|
| <p>B Krone x 6</p>  <p>M8x45mm</p> | <p>K Nüsse x 8</p>  | <p>N Stopper x 1</p>  |
|--|--|--|