

MONTAGEANLEITUNG

Artikelnummer: N634P184900K

(Numéro d'article) N634P184901K

N634P184902K

N634P184903K

N634P184904K

Dieses Set ist in 5 Boxen enthalten. Wenn Sie keine vollen 5 Boxen erhalten, wenden Sie sich bitte an unseren Kundenservice

(Cet ensemble est livré dans 5 boîtes. Si vous avez envie de 5 boîtes, si vous voulez un service client gratuit)

BUNK BED

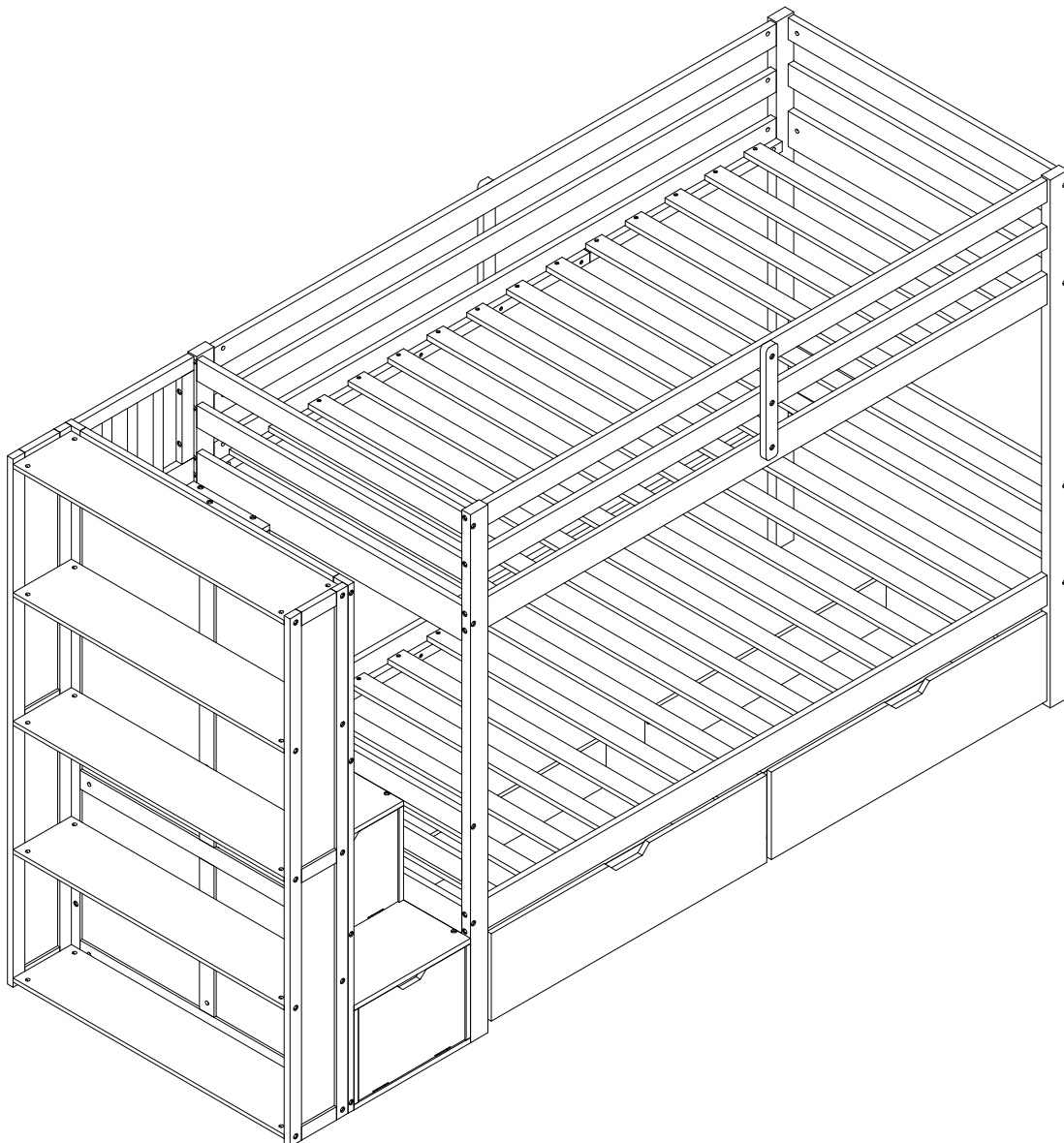

! SAFETY WARNINGS !

1. Please read the instructions fully before assembly. These instructions include important information which could ensure correct assembly. We have been working on providing high quality products for you. However, in the rare instance that your product is defective, missing parts or there are some issues, please don't hesitate to contact our customer service to submit parts requirements, assembly suggestion, or warranty claims, and we will give the best solution as soon as possible. If necessary, we need you to provide some more clear pictures of the issue.
2. Insert the screws in holes and tighten the screws, but not too tight, 70% is ok, finally tighten all the screws. If some issues happened that some screws can not target to the hole or some parts are difficult to install, please adjust the tightness of the screws.
3. 2 people are recommended to finish.
4. Instructions for use.

IMPORTANT - READ CAREFULLY - RETAIN FOR FUTURE REFERENCE

The instructions for use shall include at least the following information:

- a) WARNING " High beds and the upper bed of bunk beds are not suitable for children under six years due to the risk of injury from falls";
- b) WARNING " Bunk beds and and high beds can present a serious risk of injury from strangulation if not used correctly. Never attach or hang items to any part of the bunk bed that are not designed to be used with the bed, for example, but not limited to ropes, strings, cords, hooks, belts and bags";
- c) WARNING " Children can become trapped between the bed and the wall, a roof pitch, the ceiling, adjoining pieces of furniture (e.g. cupboards) and the like. To avoid risk of serious injury the distance between the top safety barrier and the adjoining structure shall not exceed 75 mm or shall be more than 230 mm";
- d) WARNING Do not use the bunk bed/high bed if any structural part is broken or missing;
- e) Always follow the manufacture's instructions;
- f) The recommended size of the mattress(es): 90x200 cm
- g) A statement that ventilation of the room is necessary in order to keep the humidity low and to prevent mould in and around the bed;
- h) All bunk beds and high beds intended to be assembled by other than the manufacturer or his/her representative shall include assembly instructions including a list of the parts supplied and details of any tools required to assemble the bed;
- i) Instructions regarding positioning and connection of the means of access;
- j) The maximum thickness of the mattress as well as information regarding the mattress maximum thickness marking: 15 cm
- k) A statement to check regularly that all assembly fastenings are properly tightened;
- l) The number and year of this European Standard: EN747-1&2:2012+A1:2015

! AVERTISSEMENTS DE SÉCURITÉ !

1. Veuillez lire entièrement les instructions avant l'assemblage. Ces instructions contiennent des informations importantes qui pourraient garantir un assemblage correct. Nous avons travaillé pour vous fournir des produits de haute qualité. Cependant, dans les rares cas où votre produit est défectueux, qu'il manque des pièces ou qu'il y a des problèmes, n'hésitez pas à contacter notre service client pour soumettre des exigences en matière de pièces, des suggestions d'assemblage ou des réclamations au titre de la garantie, et nous vous proposerons la meilleure solution. dès que possible. Si nécessaire, nous avons besoin que vous fournissiez des images plus claires du problème.
2. Insérez les vis dans les trous et serrez les vis, mais pas trop fort, 70% c'est ok, serrez enfin toutes les vis. Si des problèmes surviennent et que certaines vis ne peuvent pas cibler le trou ou que certaines pièces sont difficiles à installer, veuillez ajuster le serrage des vis.
3. Il est recommandé d'être 2 personnes pour terminer.
4. Mode d'emploi

IMPORTANT – À LIRE ATTENTIVEMENT – À CONSERVER POUR RÉFÉRENCE FUTURE

Les instructions d'utilisation doivent inclure au moins les informations suivantes :

- a) AVERTISSEMENT " Les lits surélevés situés dans le lit supérieur des lits superposés ne conviennent pas aux enfants de moins de six ans en raison du risque de blessure en cas de chute " ;
- b) AVERTISSEMENT " Les lits superposés et les lits surélevés peuvent présenter un risque sérieux de blessure par strangulation s'ils ne sont pas utilisés correctement. N'attachez ou ne suspendez jamais d'objets à une partie du lit superposé qui ne sont pas conçus pour être utilisés avec le lit, par exemple, mais sans s'y limiter, des cordes, des ficelles, des cordons, des crochets, des ceintures et des sacs".
- c) AVERTISSEMENT "Les enfants peuvent se coincer entre le lit et le mur, une pente du toit, le plafond, des meubles attenants (par exemple des armoires), etc. Pour éviter tout risque de blessure grave, la distance entre la barrière de sécurité supérieure et la structure attenante ne doit pas dépasser 75 mm ou doit être supérieure à 230 mm " ;
- d) AVERTISSEMENT N'utilisez pas le lit superposé/lit surélevé si une pièce structurelle est cassée ou manquante ;
- e) Suivez toujours les instructions du fabricant ;
- f) La taille recommandée du ou des matelas : 90x200 cm
- g) Une déclaration selon laquelle la ventilation de la pièce est nécessaire afin de maintenir le taux d'humidité à un faible niveau et d'éviter la moisissure dans et autour du lit ;
- h) Tous les lits superposés et lits hauts destinés à être assemblés par une personne autre que le fabricant ou son représentant doivent inclure des instructions d'assemblage comprenant une liste des pièces fournies et des détails sur tous les outils requis pour assembler le lit ;
- i) Instructions concernant le positionnement et la connexion des moyens d'accès ;
- j) L'épaisseur maximale du matelas ainsi que les informations concernant le marquage de l'épaisseur maximale du matelas : 15 cm
- k) Une déclaration pour vérifier régulièrement que toutes les fixations de l'assemblage sont correctement serrées ;
- l) Le numéro et l'année de cette Norme européenne: EN747-1&2:2012+A1:2015

! SICHERHEITSWARNUNGEN !

1. Bitte lesen Sie die Anleitung vor der Montage vollständig durch. Diese Anleitung enthält wichtige Informationen, die eine korrekte Montage gewährleisten können. Wir haben daran gearbeitet, qualitativ hochwertige Produkte für Sie bereitzustellen. Sollte es jedoch in dem seltenen Fall vorkommen, dass Ihr Produkt defekt ist, Teile fehlen oder es Probleme gibt, zögern Sie bitte nicht, unseren Kundendienst zu kontaktieren, um Teileanforderungen, Montagevorschläge oder Garantieansprüche einzureichen. Wir werden Ihnen dann die beste Lösung anbieten schnellstmöglich. Bei Bedarf benötigen wir von Ihnen einige klarere Bilder des Problems.
2. Setzen Sie die Schrauben in die Löcher ein und ziehen Sie die Schrauben fest, aber nicht zu fest, 70 % sind in Ordnung, schließlich ziehen Sie alle Schrauben fest. Wenn Probleme auftreten, weil einige Schrauben nicht in das Loch passen oder einige Teile schwer zu installieren sind, passen Sie bitte den festen Sitz der Schrauben an.
3. Für die Fertigstellung werden 2 Personen empfohlen.
4. Gebrauchsanweisung

WICHTIG –SORGFÄLTIG LESEN –ZUM SPÄTEREN NACHSCHLAGEN AUFBEWAHREN

Die Gebrauchsanweisung muss mindestens die folgenden Informationen enthalten:

- a) WARNUNG "Hochbetten im oberen Bett von Etagenbetten sind aufgrund der Verletzungsgefahr durch Stürze nicht für Kinder unter sechs Jahren geeignet";
- b) WARNUNG "Etagenbetten und Hochbetten können bei unsachgemäßer Verwendung eine ernsthafte Verletzungsgefahr durch Strangulation darstellen. Befestigen oder hängen Sie niemals Gegenstände an Teilen des Etagenbetts auf, die nicht für die Verwendung mit dem Bett vorgesehen sind, beispielsweise, aber nicht beschränkt auf, Seile, Schnüre, Kordeln, Haken, Gürtel und Taschen"
- c) WARNUNG " Kinder können zwischen Bett und Wand, Dachschräge, Decke, angrenzenden Möbelstücken (z. B. Schränken) und dergleichen eingeklemmt werden. Um das Risiko schwerer Verletzungen zu vermeiden, darf der Abstand zwischen der oberen Sicherheitsbarriere und der angrenzenden Struktur 75 mm nicht überschreiten oder muss mehr als 230 mm betragen";
- d) WARNUNG Verwenden Sie das Etagenbett/Hochbett nicht, wenn ein Strukturteil gebrochen ist oder fehlt;
- e) Befolgen Sie stets die Anweisungen des Herstellers;
- f) Die empfohlene Größe der Matratze(n): 90x200 cm
- g) Ein Hinweis, dass eine Belüftung des Raums erforderlich ist, um die Luftfeuchtigkeit niedrig zu halten und Schimmel im und um das Bett herum zu verhindern;
- h) Alle Etagenbetten und Hochbetten, die nicht vom Hersteller oder seinem Vertreter zusammengebaut werden sollen, müssen eine Montageanleitung mit einer Liste der mitgelieferten Teile und Einzelheiten zu allen zum Zusammenbau des Bettes erforderlichen Werkzeugen enthalten;
- i) Anweisungen zur Positionierung und zum Anschluss der Zugangsmittel;
- j) Die maximale Dicke der Matratze sowie Informationen zur Kennzeichnung der maximalen Matratzendicke: 15 cm
- k) Ein Hinweis, regelmäßig zu überprüfen, ob alle Montagebefestigungen richtig festgezogen sind;
- l) Die Nummer und das Jahr dieser europäischen Norm: EN747-1&2:2012+A1:2015

Stückliste /Liste bloquée

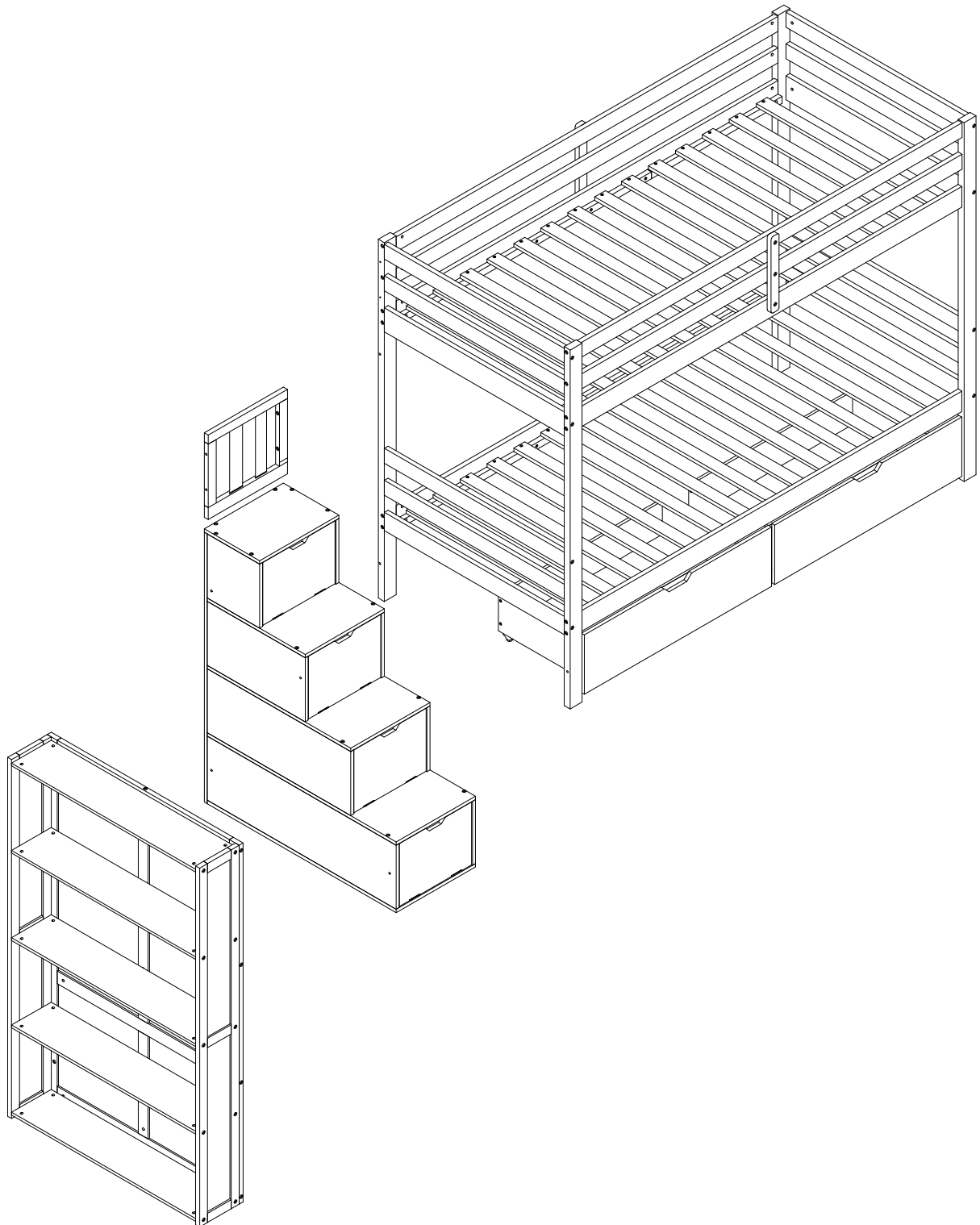

Stückliste /Liste bloquée

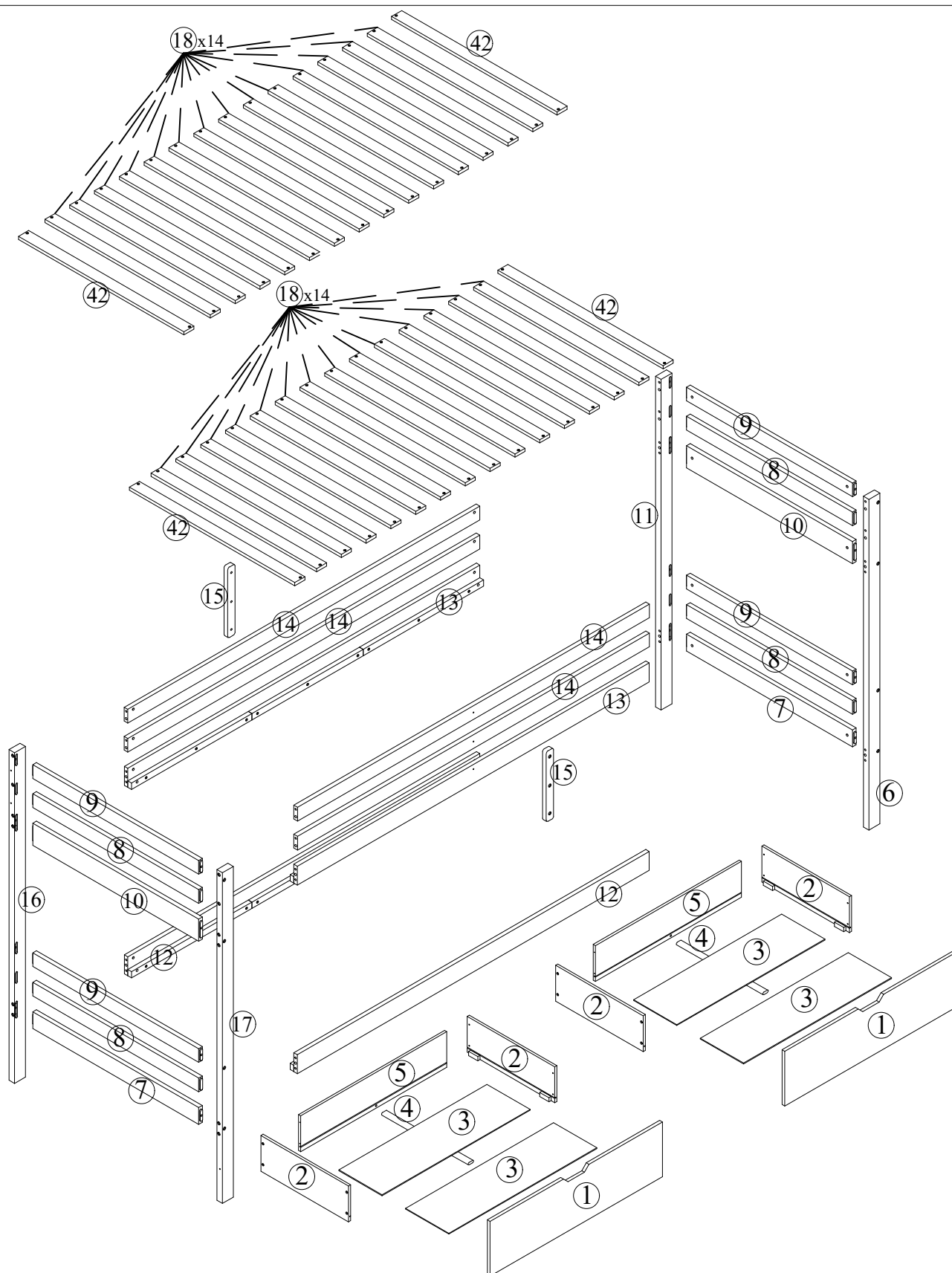

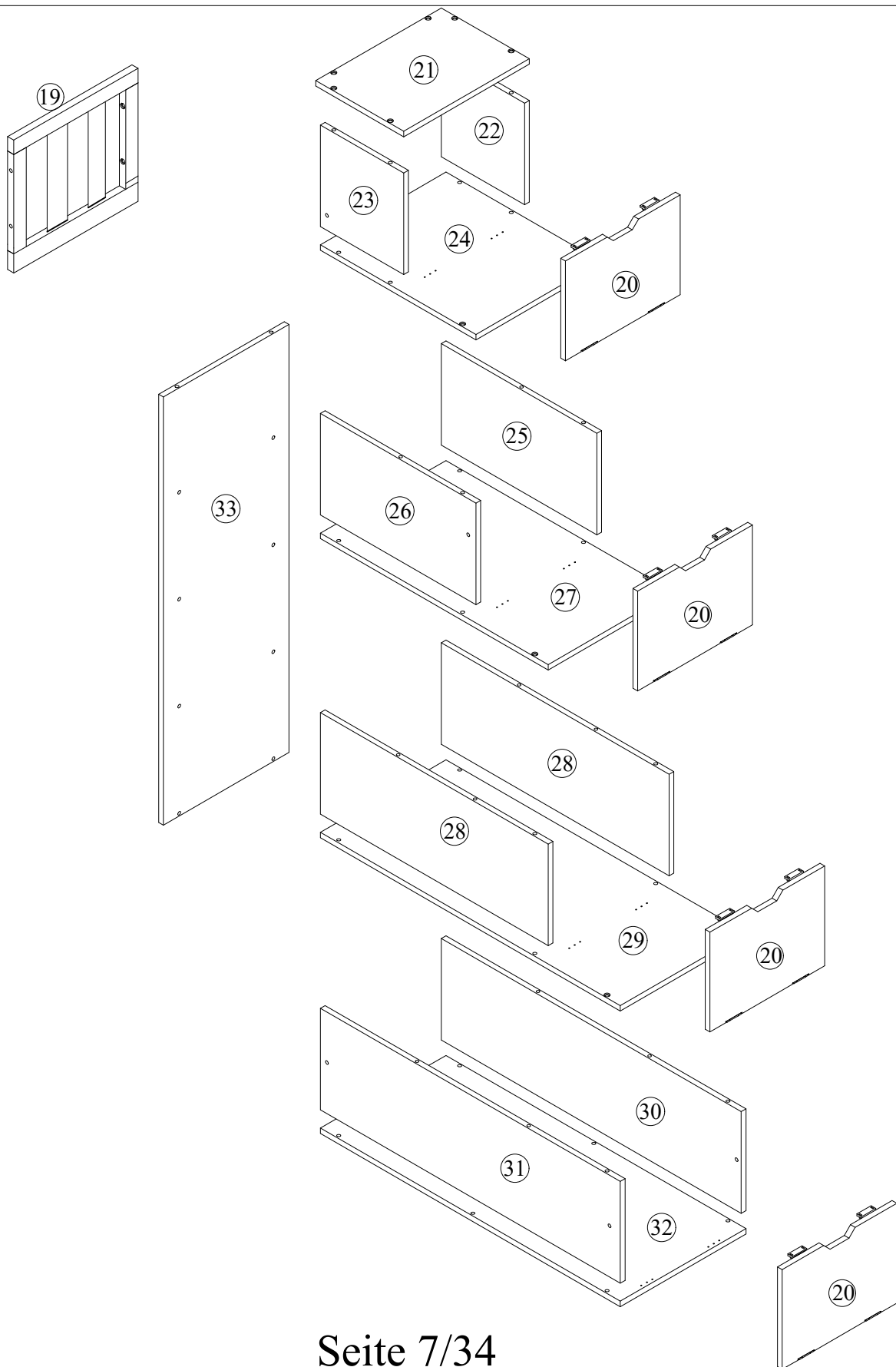

Stückliste /Liste bloquée



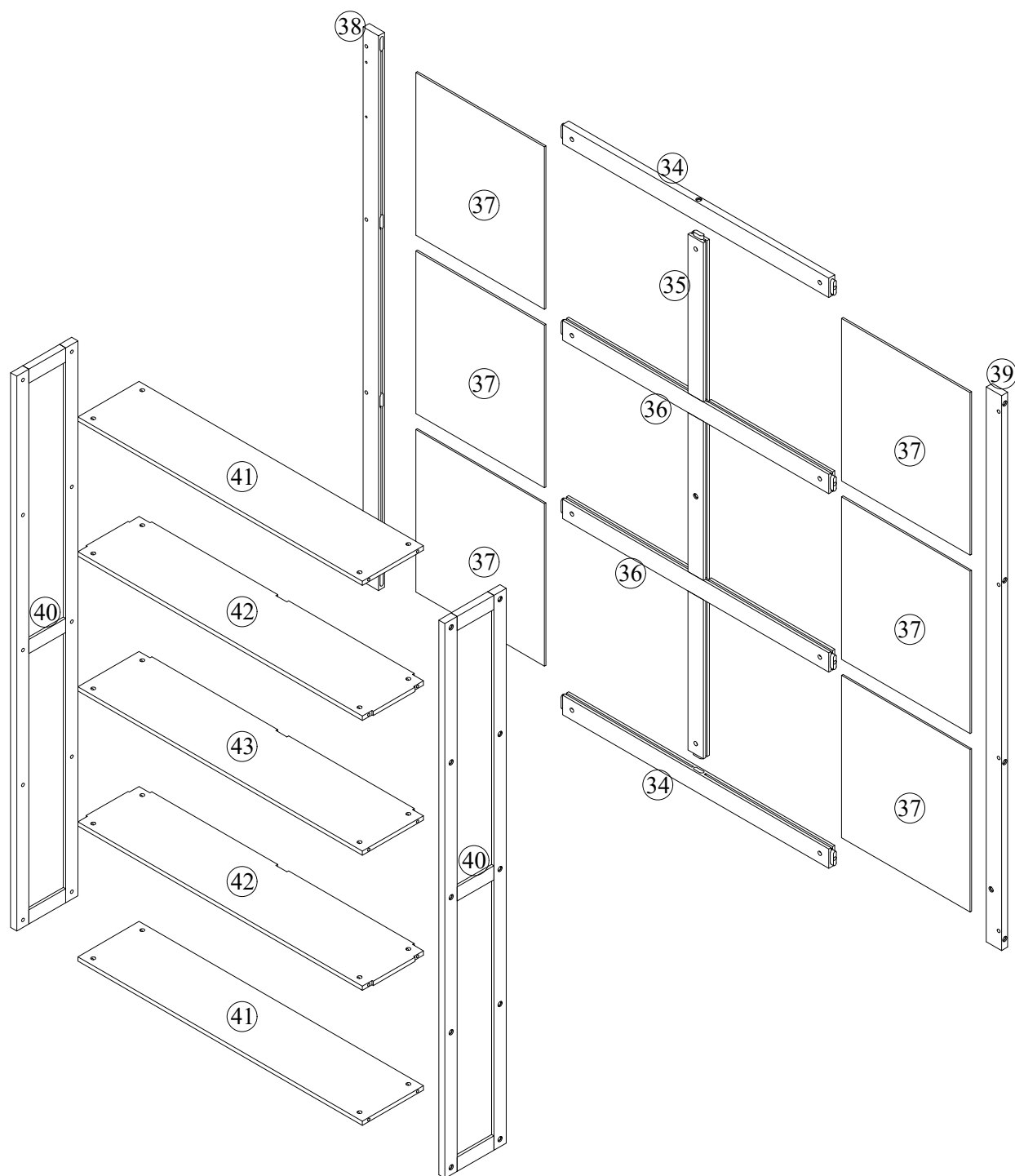

Stückliste /Liste bloquée

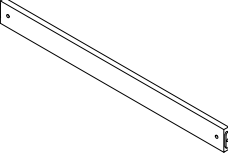
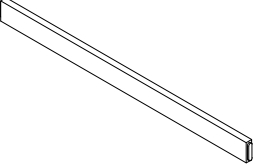
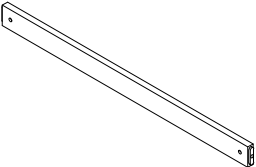
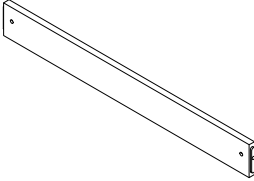
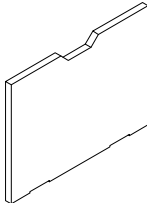
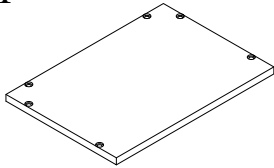

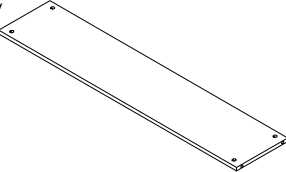
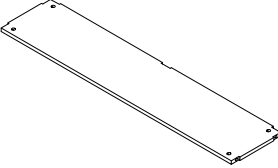
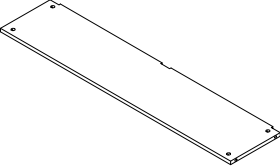

N634P184900K (Stückliste Und Hardware-Liste/ Liste du matériel)

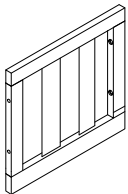
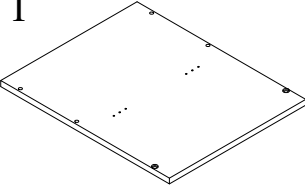
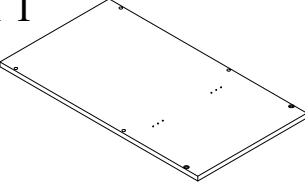
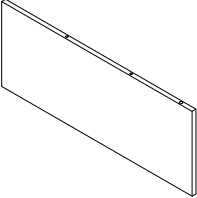
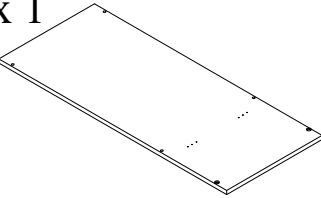
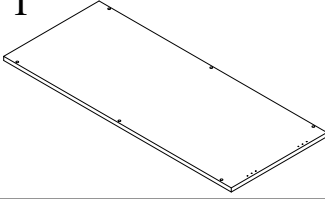
7 x 2 	8 x 4 	9 x 4 
10 x 2 	20 x 4 	21 x 1 
40 x 2 	41 x 2 	42 x 2 
43 x 1 		

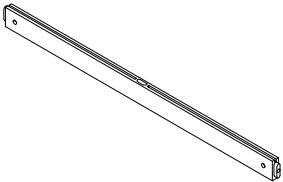
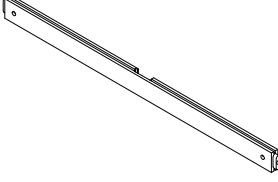

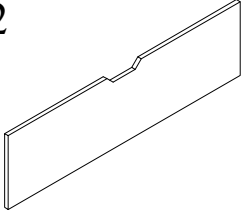

N634P184901K

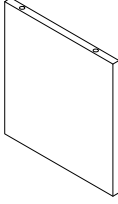
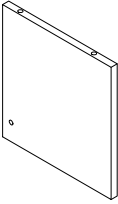
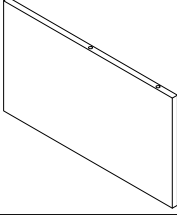
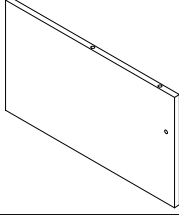
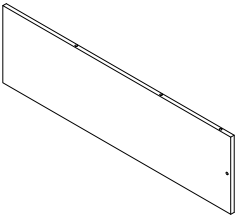
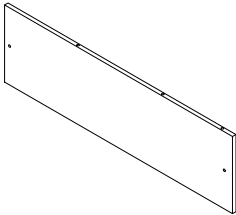
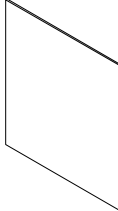
19 x 1 	24 x 1 	27 x 1 
28 x 2 	29 x 1 	32 x 1 
33 x 1 	34 x 2 	36 x 2 

N634P184902K

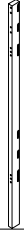
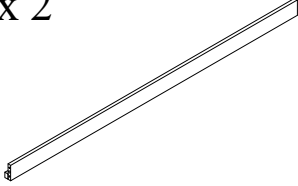
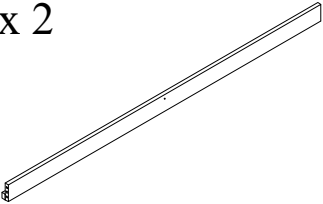
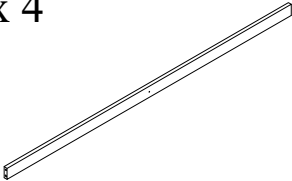
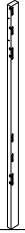
1×2 	15×2 	22×1 
23×1 	25×1 	26×1 
30×1 	31×1 	37×6 

N634P184903K

6×1 	11×1 	12×2 
13×2 	14×4 	16×1 
17×1 	35×1 	38×1 
39×1 		

N634P184904K

2 x 4

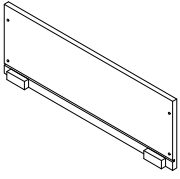

3 x 4

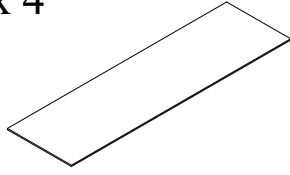

4 x 2

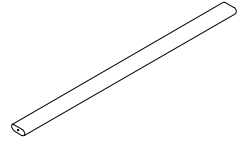

5 x 2

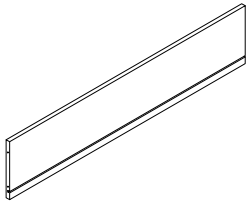



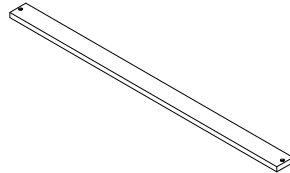



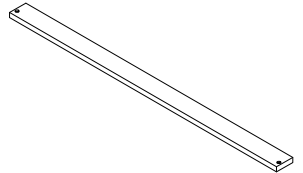



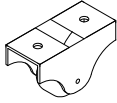

18 x 28

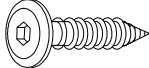
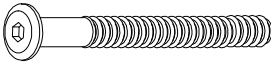

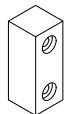
44 x 4

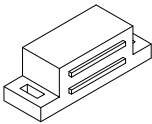

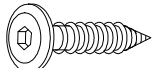
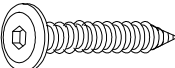
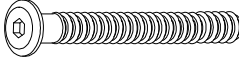
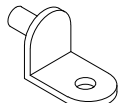
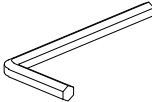
N634P184900K (Stückliste Und Hardware-Liste/ Liste du matériel)

<p>A x 88</p>  <p>Screws: M4x30</p>	<p>B x 8</p>  <p>Wheels: H= 28 mm</p>	<p>C x 16</p>  <p>Screws: M4x15</p>
<p>D x 18</p>  <p>Bolt: M6x75</p>	<p>E x 70</p>  <p>Hole Bolt: M6x13</p>	<p>F x 6</p>  <p>Bolt Screws: M6x30</p>
<p>G x 24</p>  <p>Bolt: M6x110</p>	<p>H x 16</p>  <p>Wood dowel: Ø10x40</p>	<p>I x 3</p>  <p>Stop Drawer: 20x20x50</p>
<p>J x 42</p>  <p>Bolt: M6x30</p>	<p>K x 10</p>  <p>Wood dowel: Ø8x30</p>	<p>L x 8</p>  <p>15x15x46</p>
<p>M x45</p>  <p>Screws: M3x12</p>	<p>N x 10</p>  <p>Bolt: M6x100</p>	<p>O x 8</p>  <p>Bolt Screws: M6x40</p>
<p>P x 4</p>  <p>Bolt Screws: M6x60</p>	<p>Q x 20</p>  <p>Bolt: M6x65</p>	<p>R x 5</p>  <p>2x14x30</p>
<p>S x 1</p>  <p>Allen Key: 4x70</p>	<p>T x 1</p>  <p>Bolt: M6x70</p>	

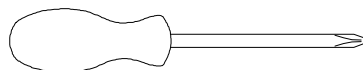

Assembly Tools Required (Not Included)

Wichtiger Hinweis:

Bestatigen Sie bitte alle Komponenten und Schrauben vor der Montage. Bitte wenden Sie sich an uns, falls einige Teile oder Schrauben im Paket fehlt sind.

Outils d'assemblage requis (non inclus)

Signification du Wichtiger :

Bestatigen Sie bitte alle Komponenten and Schrauben vor der Montage. Bitte wenden Sie sich an us, Falls einige Teile ou Schrauben im paket fehlt sind.

Schritt 1-1:

A

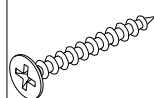

M4x30

4

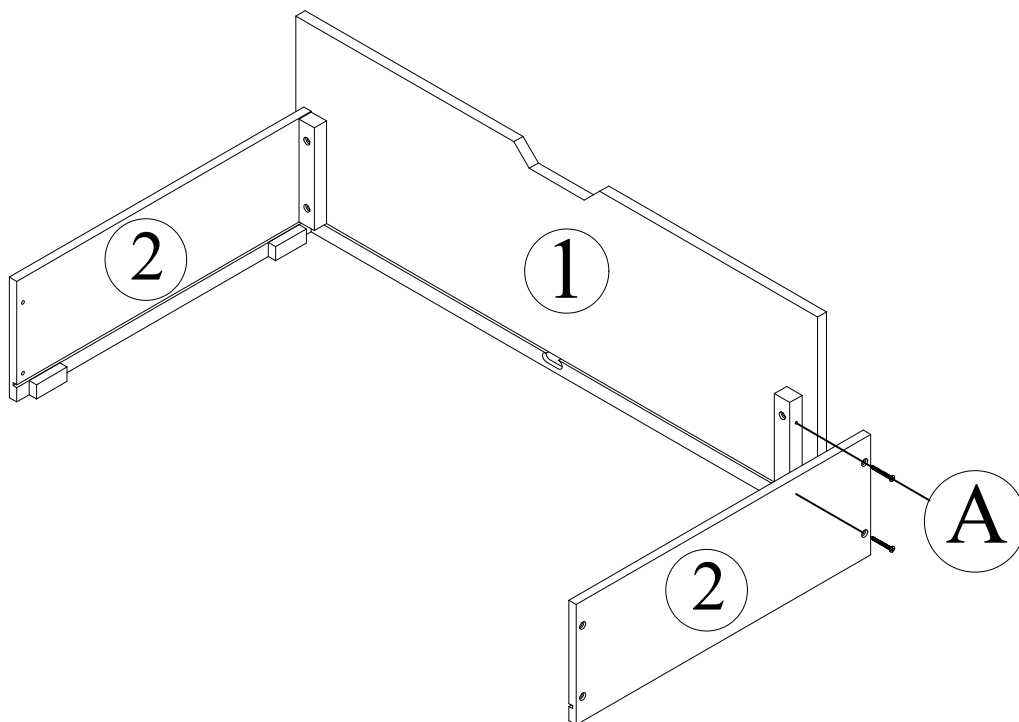

Schritt 1-2:

A

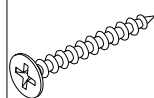

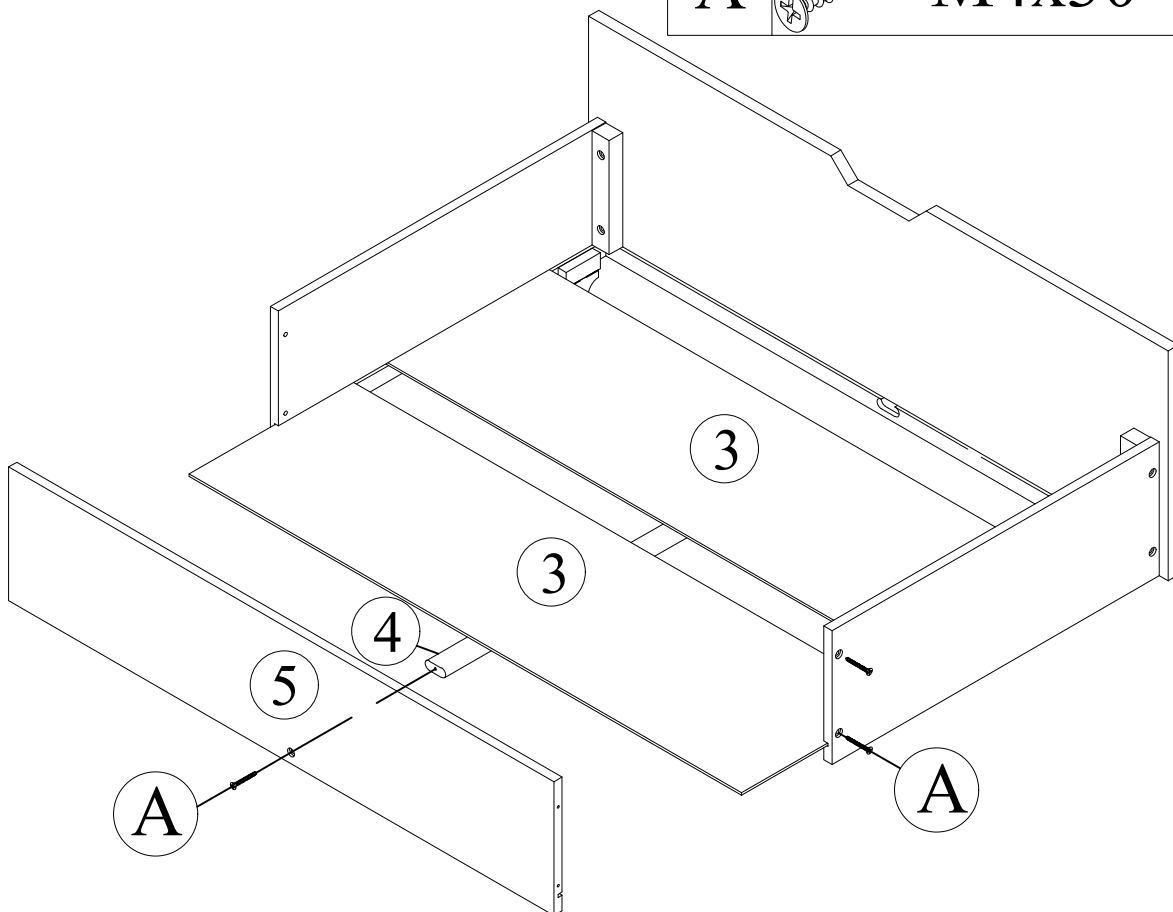

M4x30

5

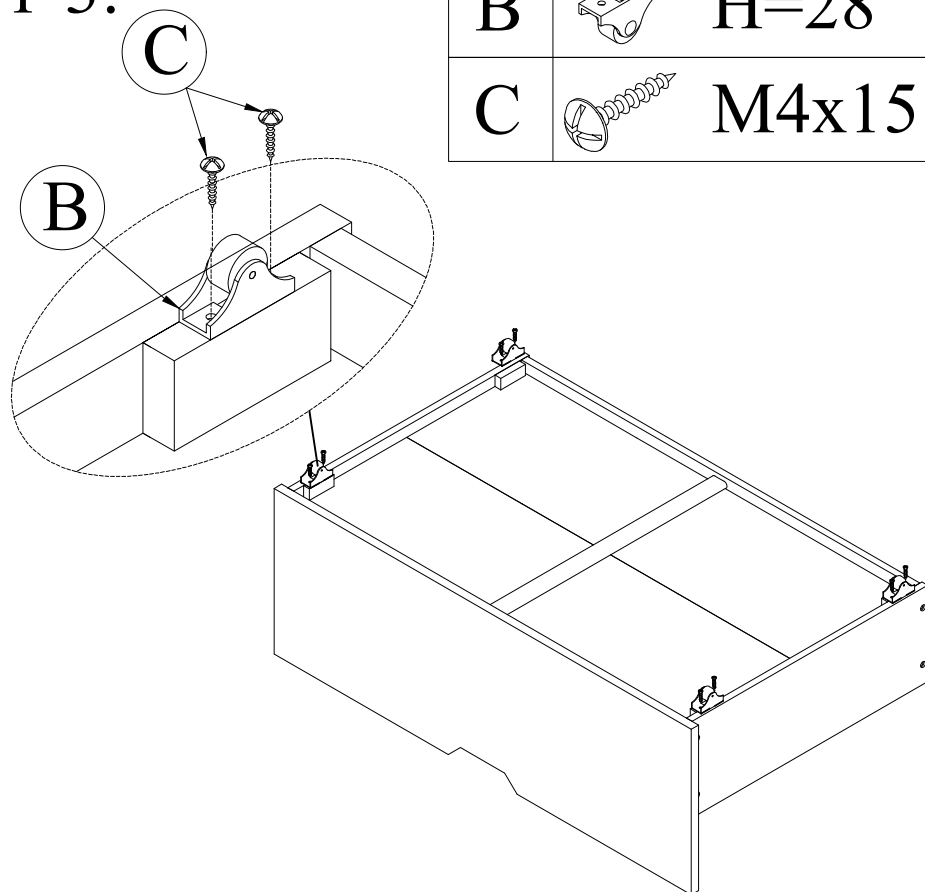

Schritt 1-3:

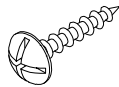

B		H=28	4
C		M4x15	8

Schritt 2-1:

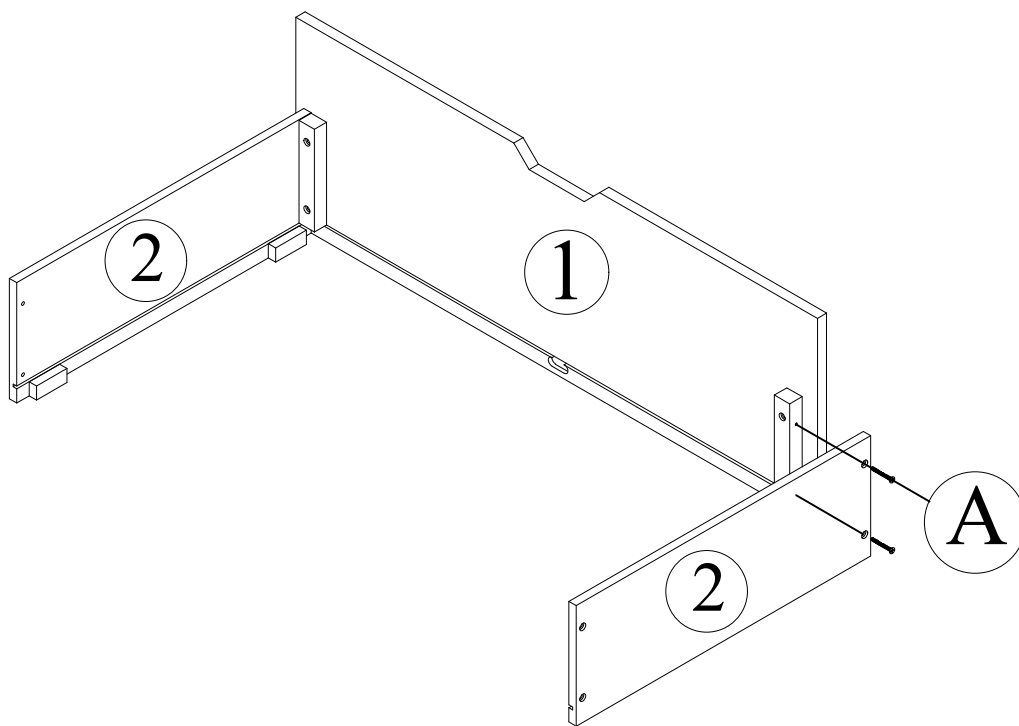

A		M4x30	4
---	--	-------	---

Schritt 2-2:

A		M4x30	5
---	--	-------	---

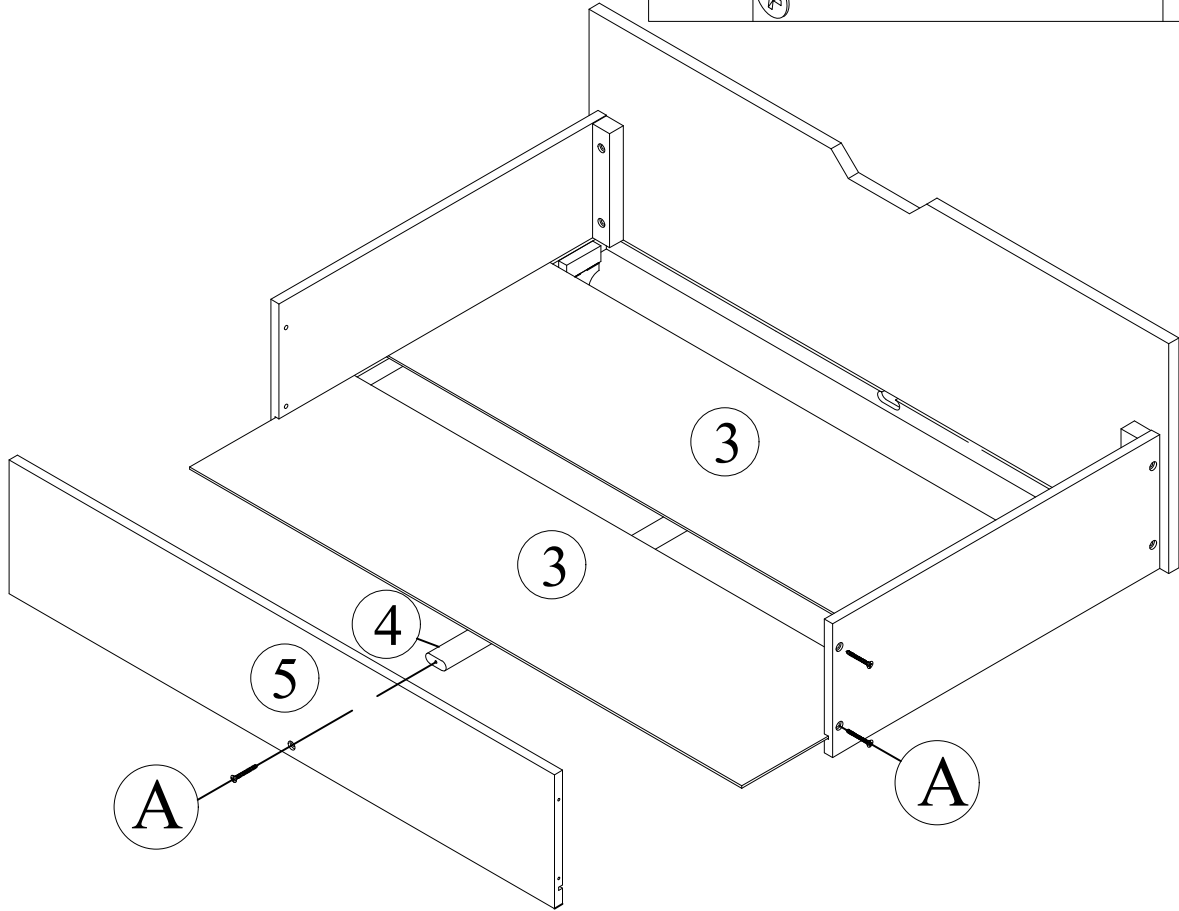

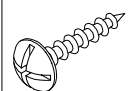

Schritt 2-3:

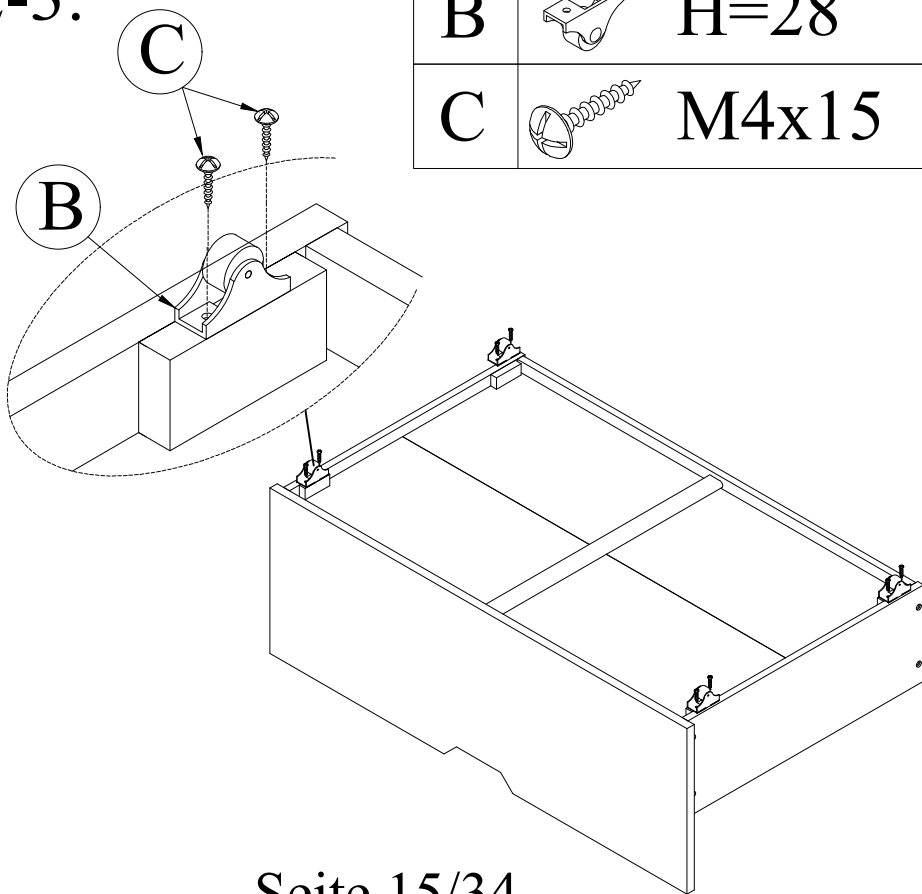
B		H=28	4
C		M4x15	8

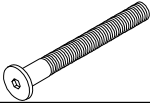

Schritt 3-1:

D		M6x75	16
E		M6x13	16

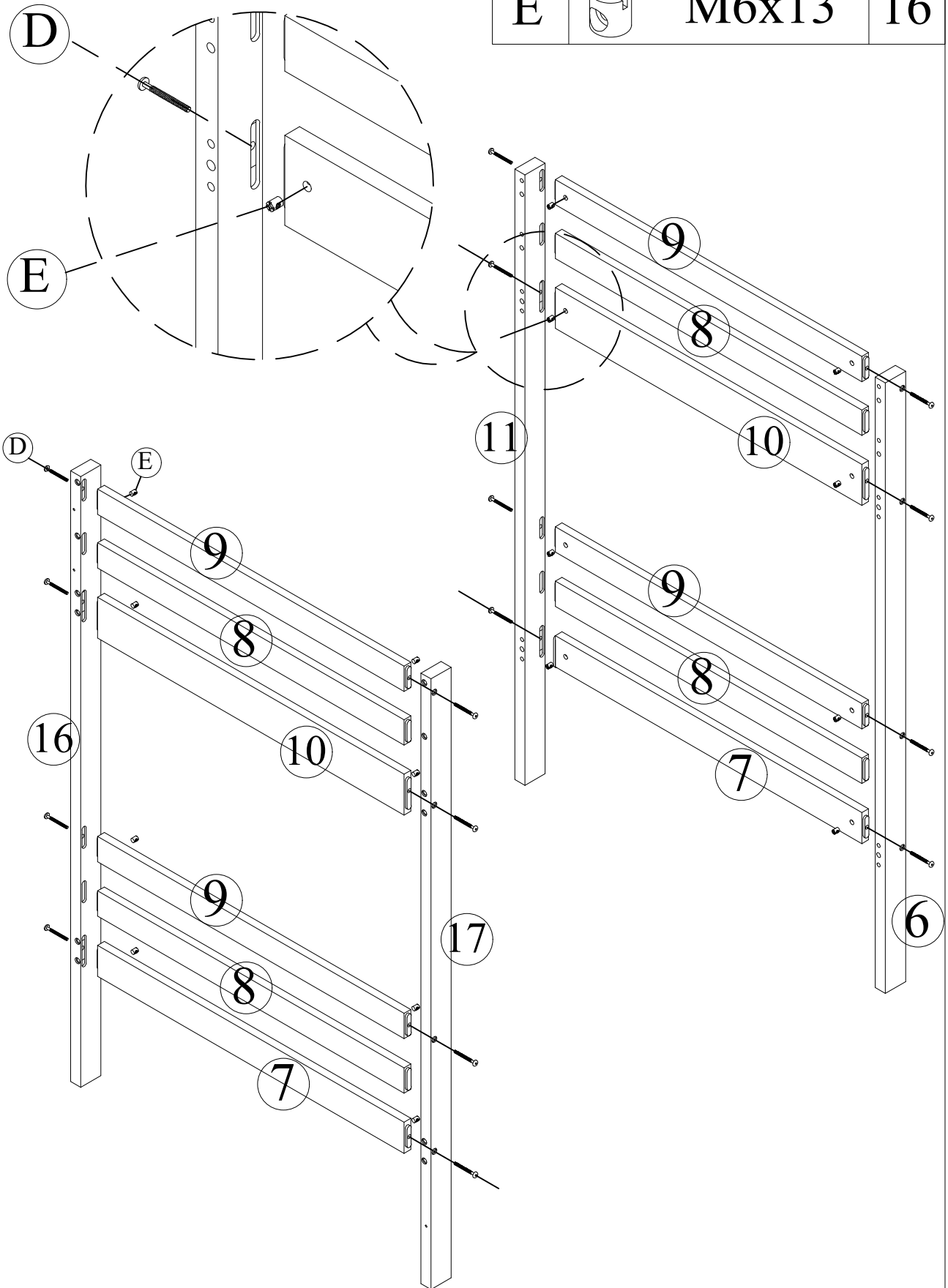

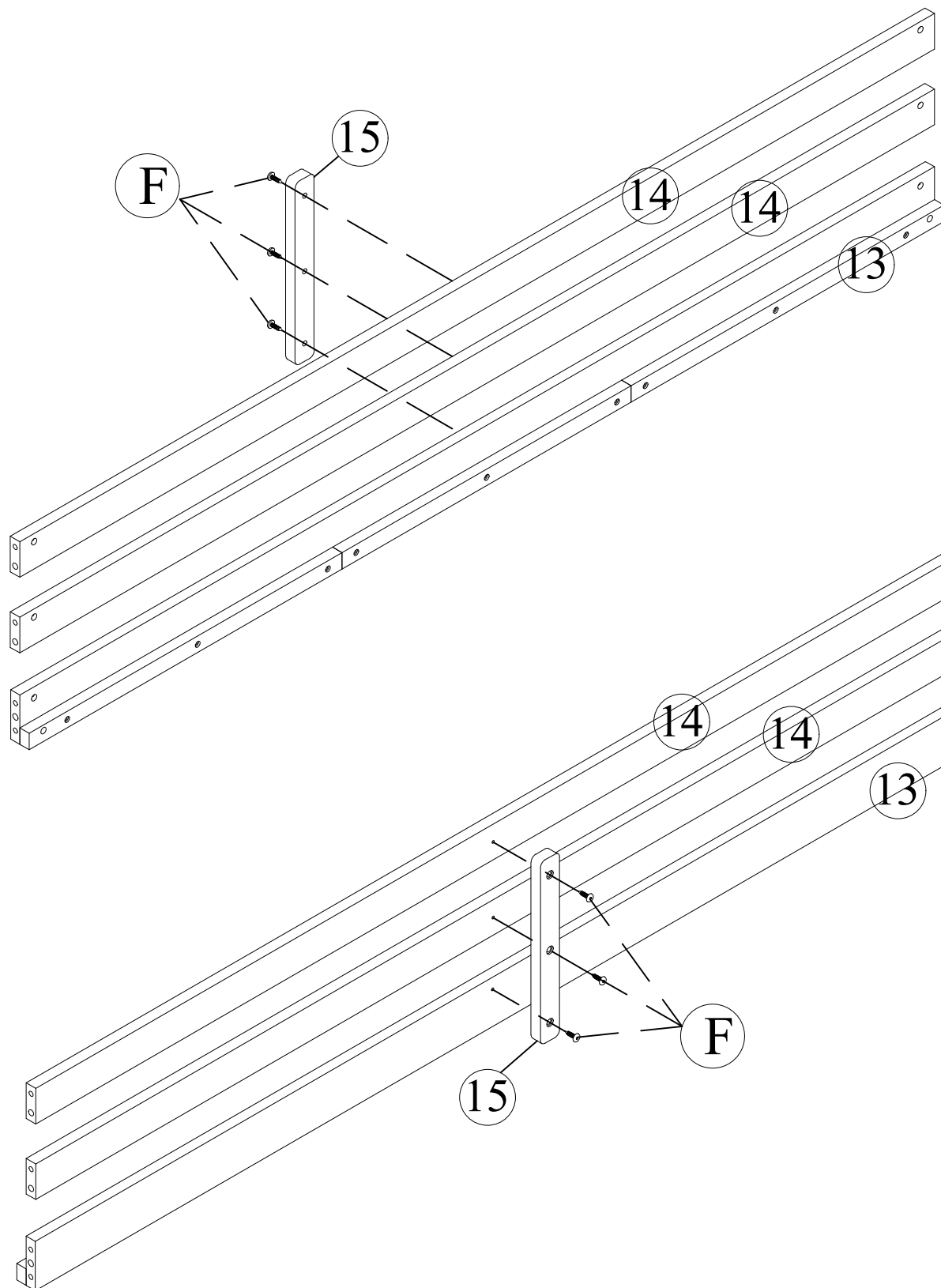

Schritt 3-2:

F		M6x30	6
---	--	-------	---



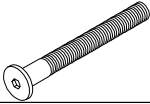

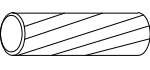
Schritt 3-3:

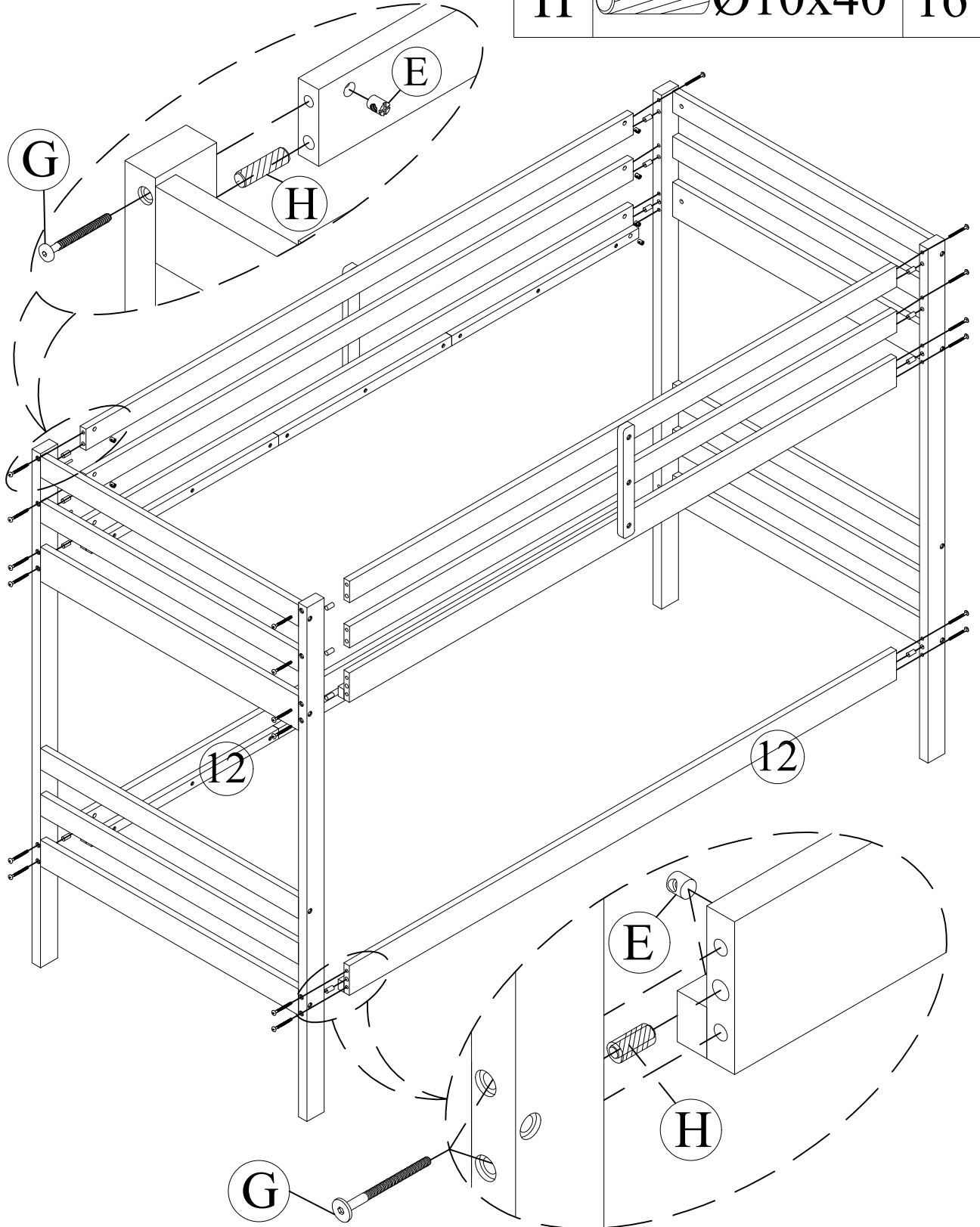
G		M6x110	24
E		M6x13	24
H		Ø10x40	16

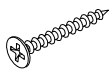

Schritt 3-4:

A	 M4x30	70
I	 20x20x50	3

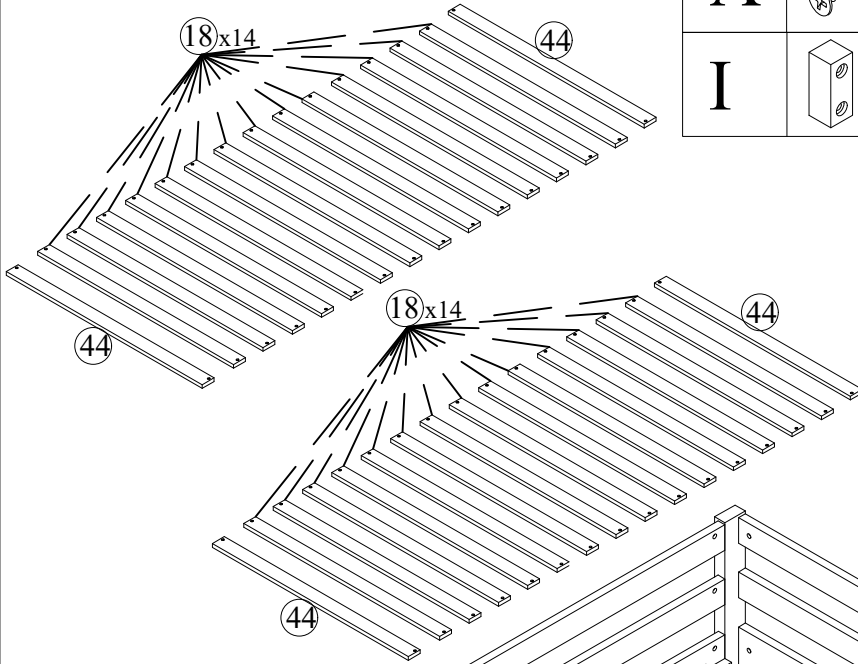

Distance of slat

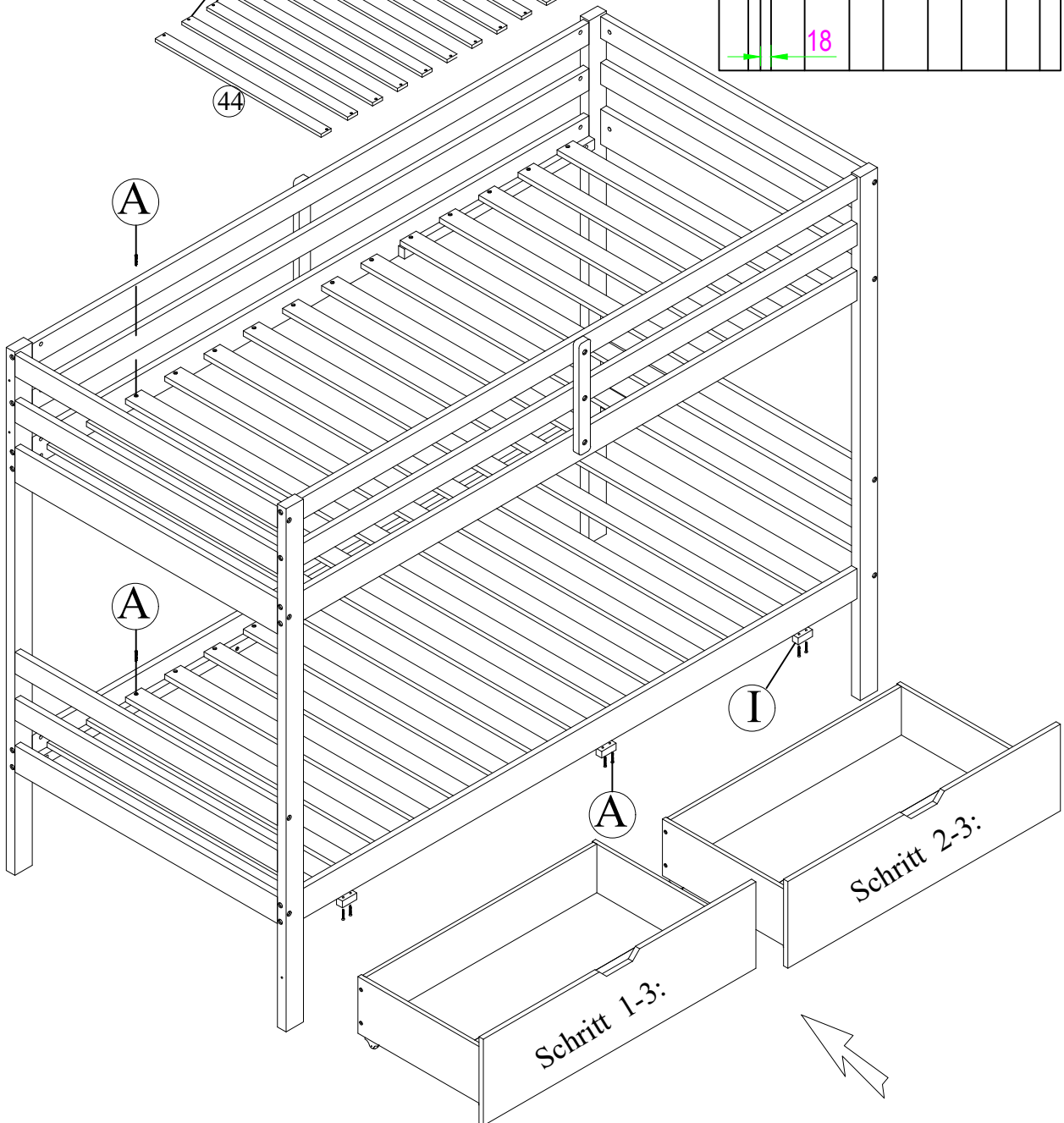
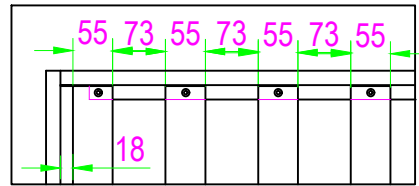

Schritt 4-1:

J

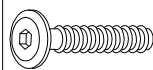

M6x30

8

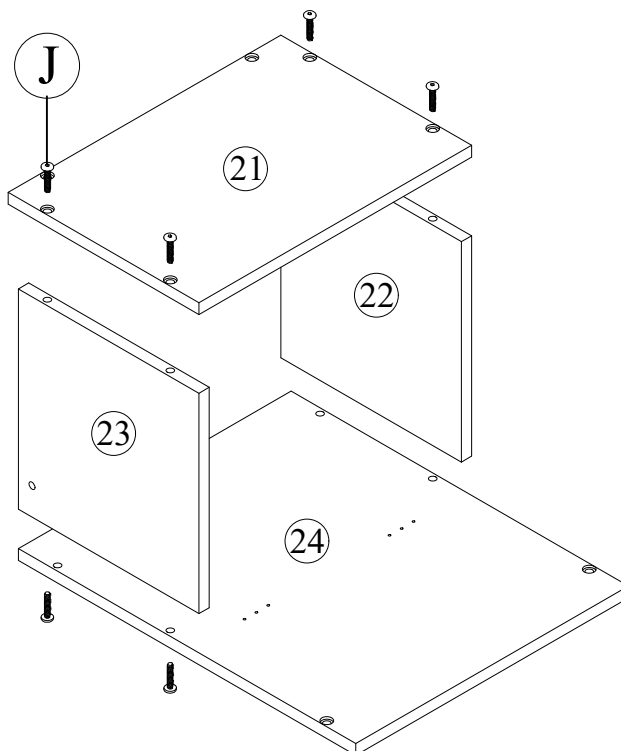
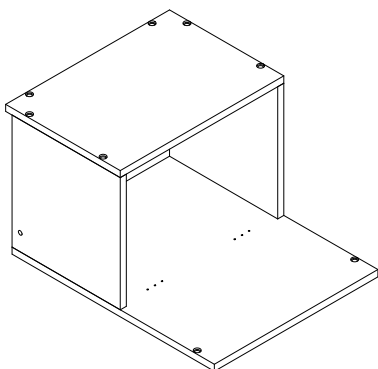

Schritt 4-2:

J

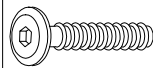

M6x30

4

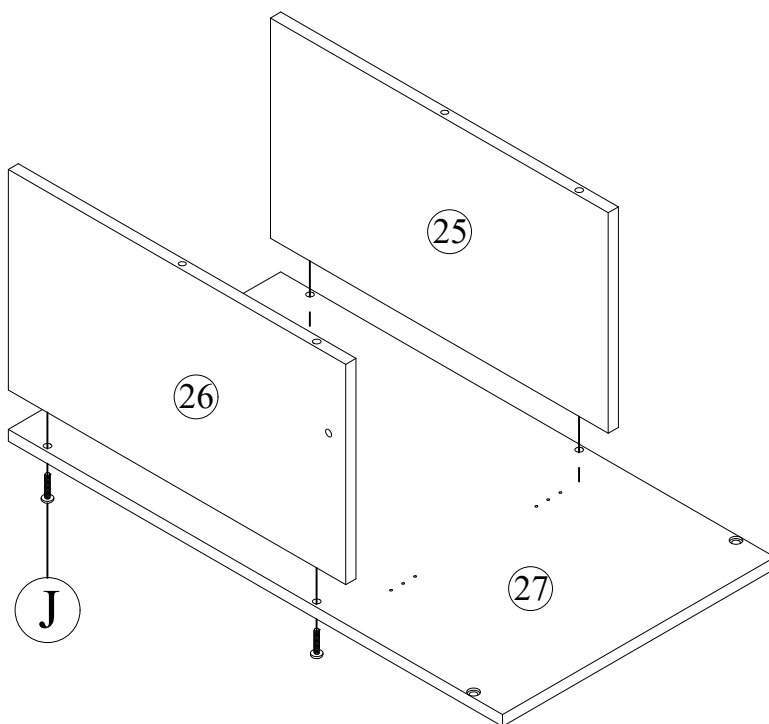
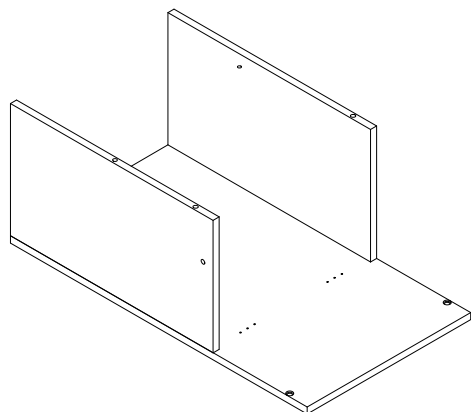

Schritt 4-3:

J

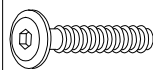

M6x30

4

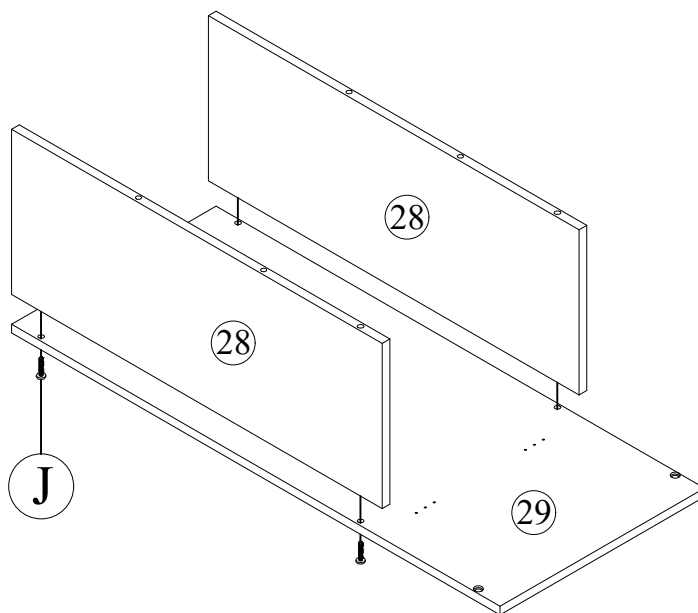
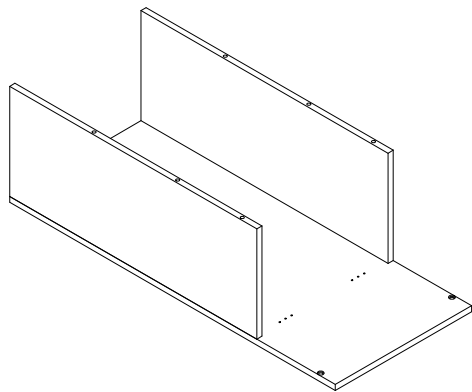

Schritt 4-4:

J

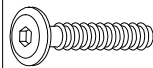

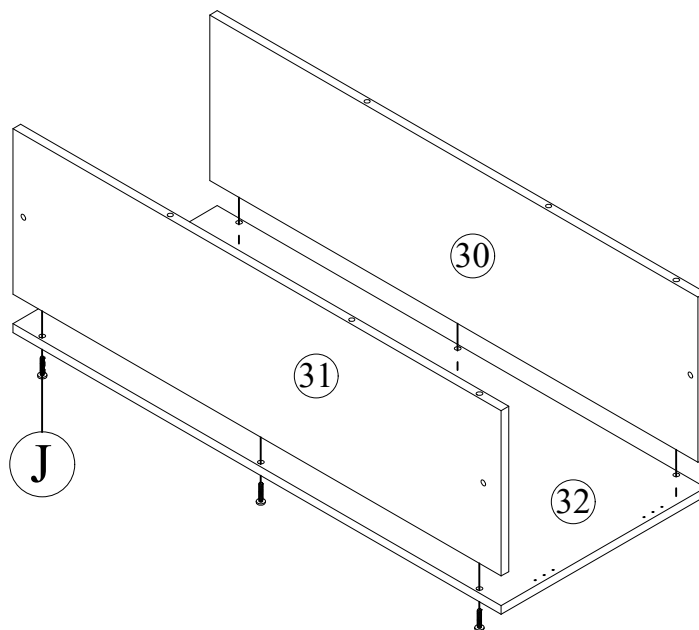
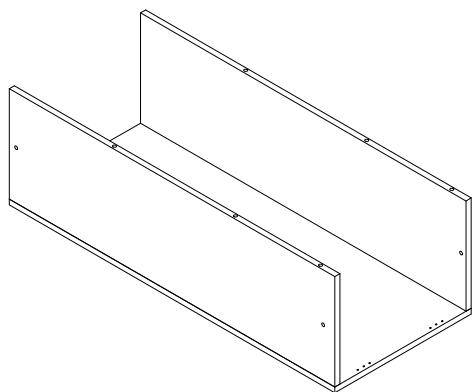

M6x30

6

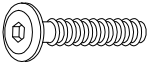

Schritt 4-5:

J		M6x30	6
K		Ø8x30	10

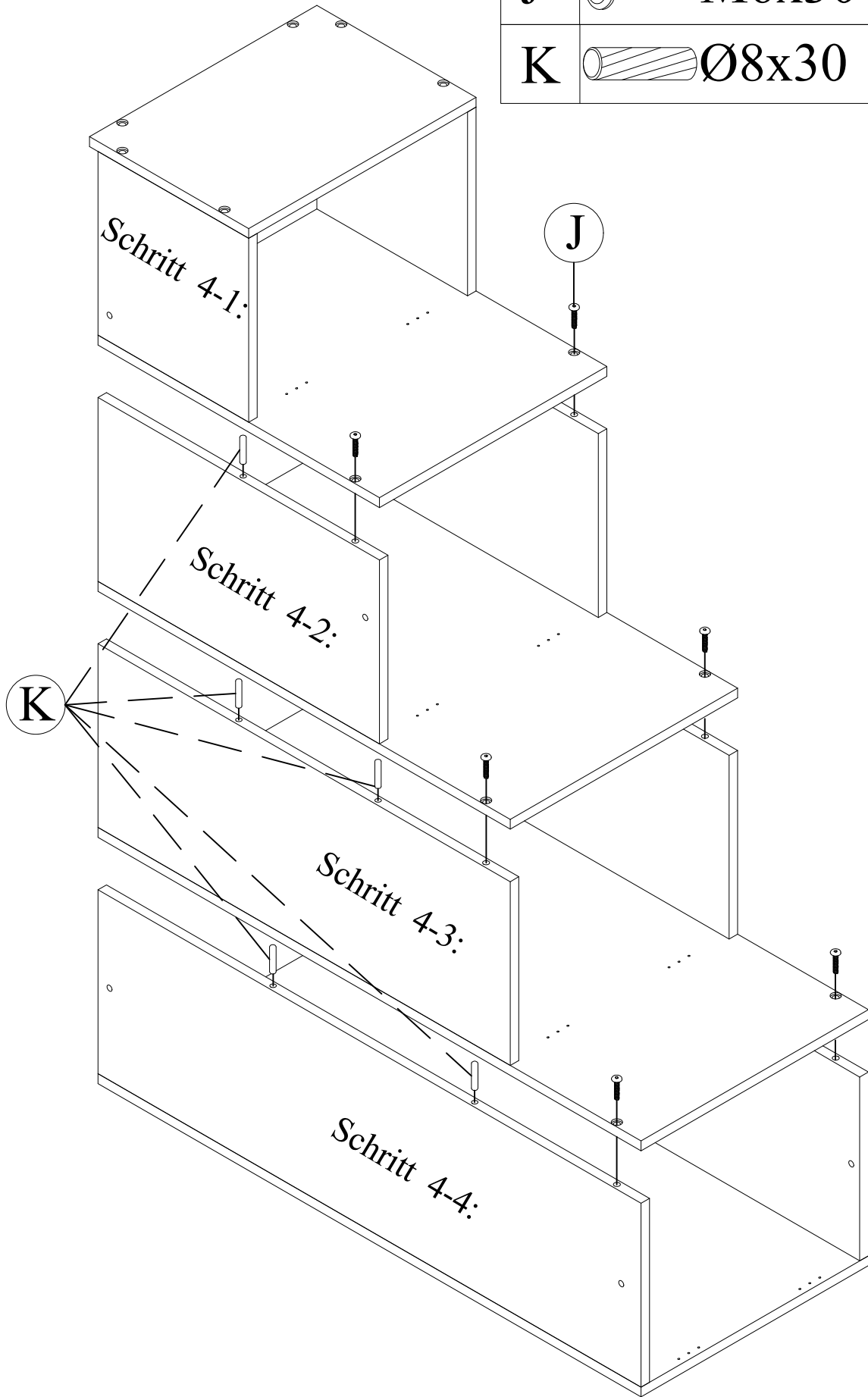

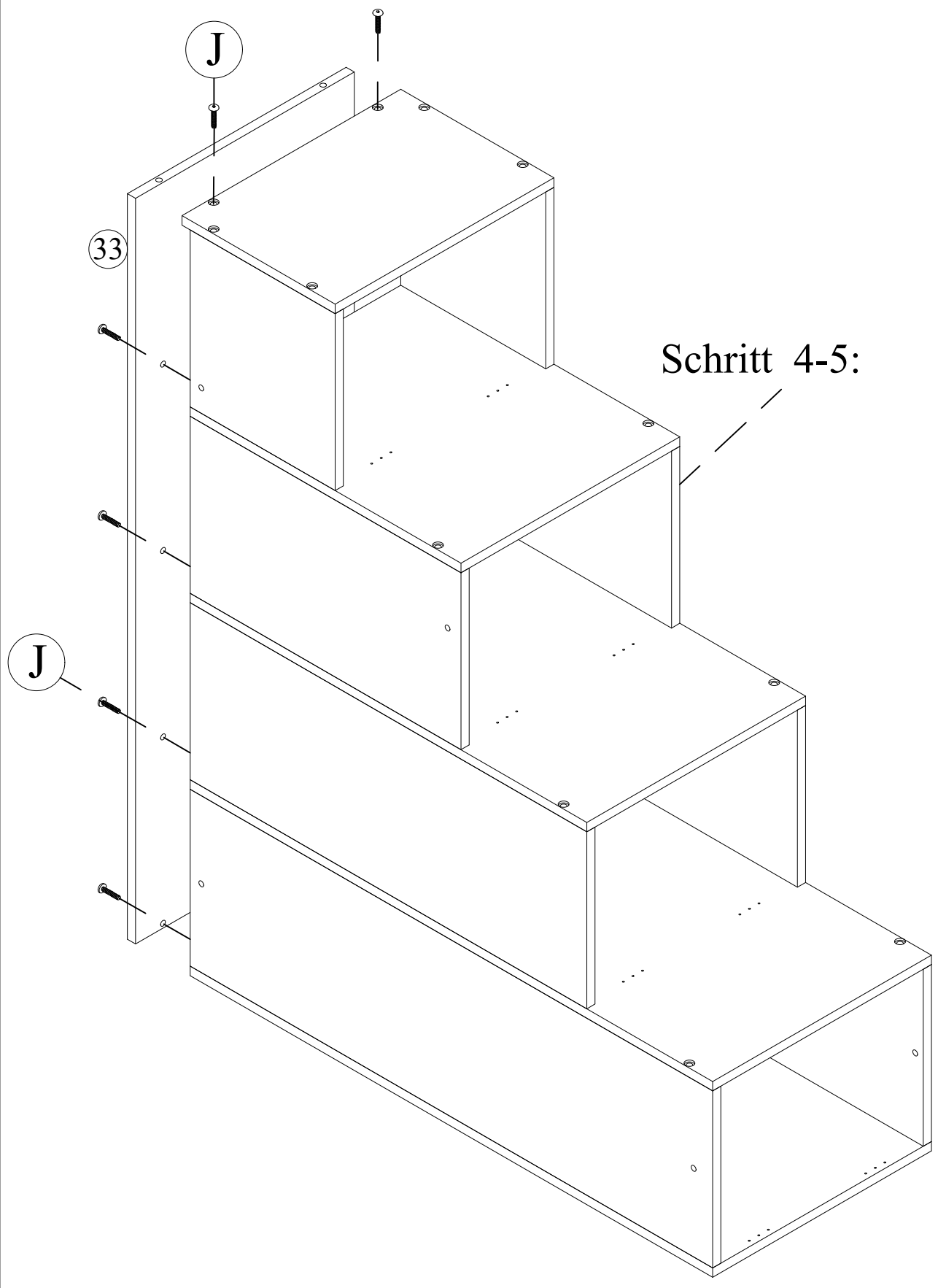

Schritt 4-6:

J		M6x30	10
---	--	-------	----

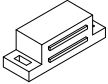

Schritt 4-7:

L		15x15x46	8
M		M3x12	16

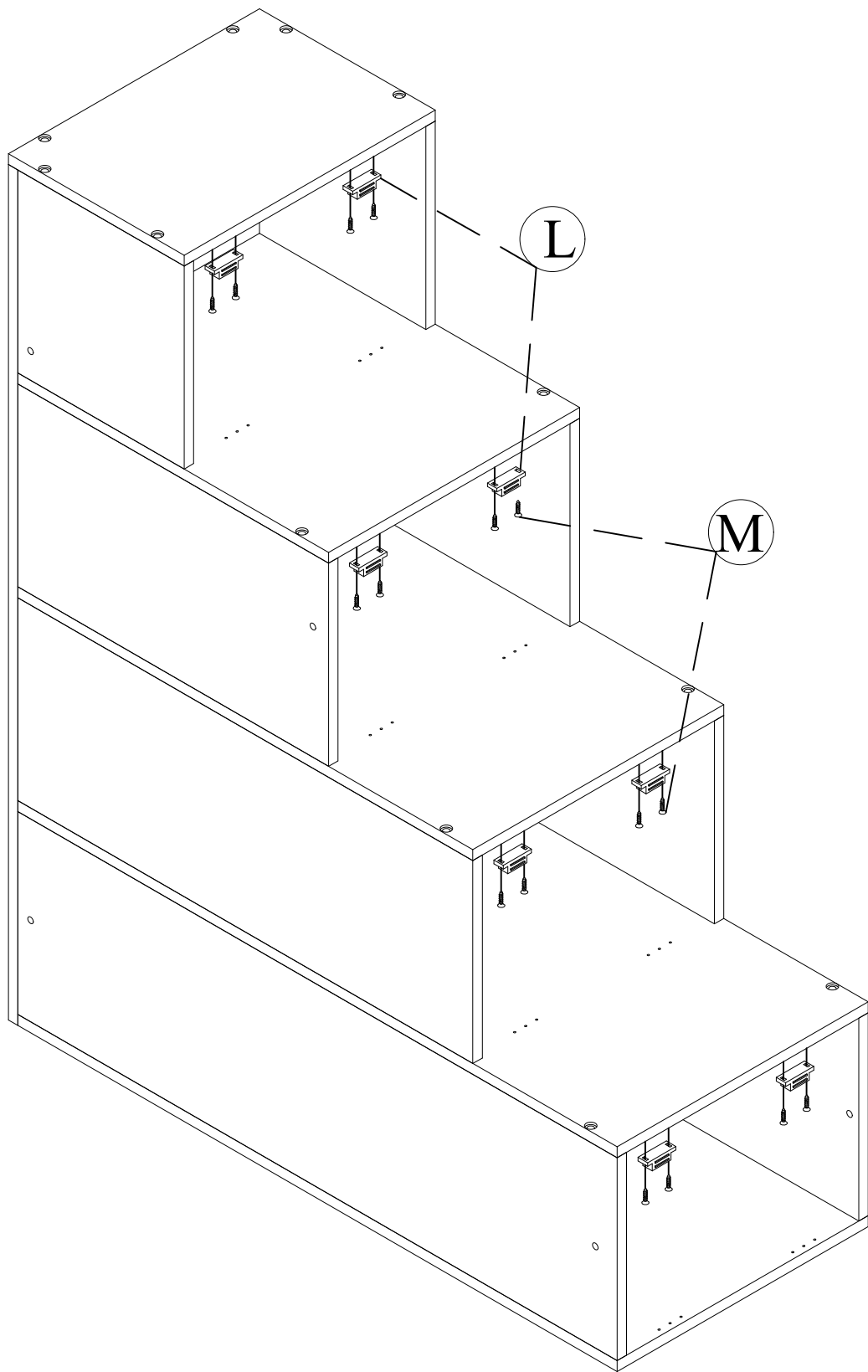

Schritt 4-8:

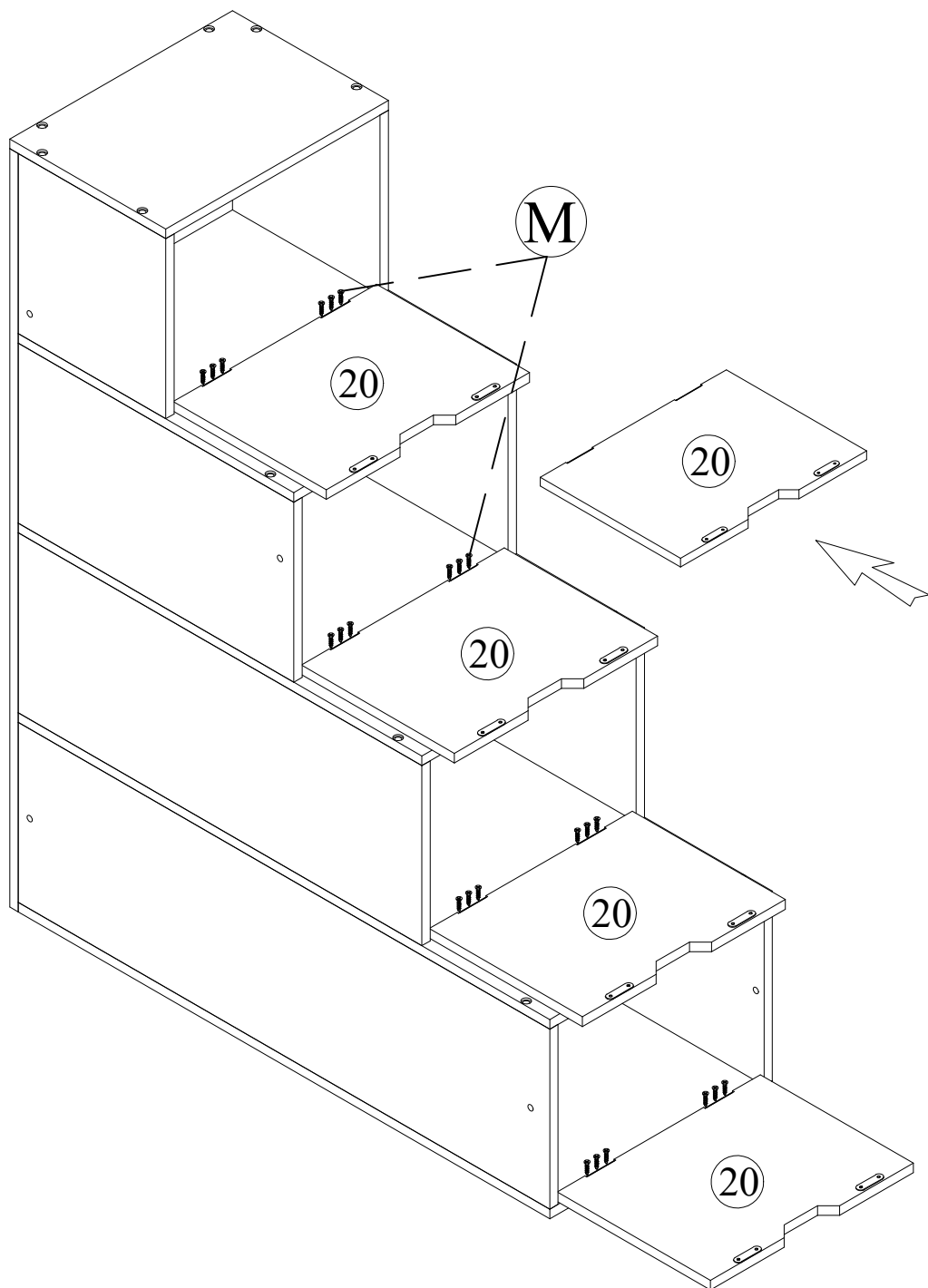

M		M3x12	24
---	---	-------	----

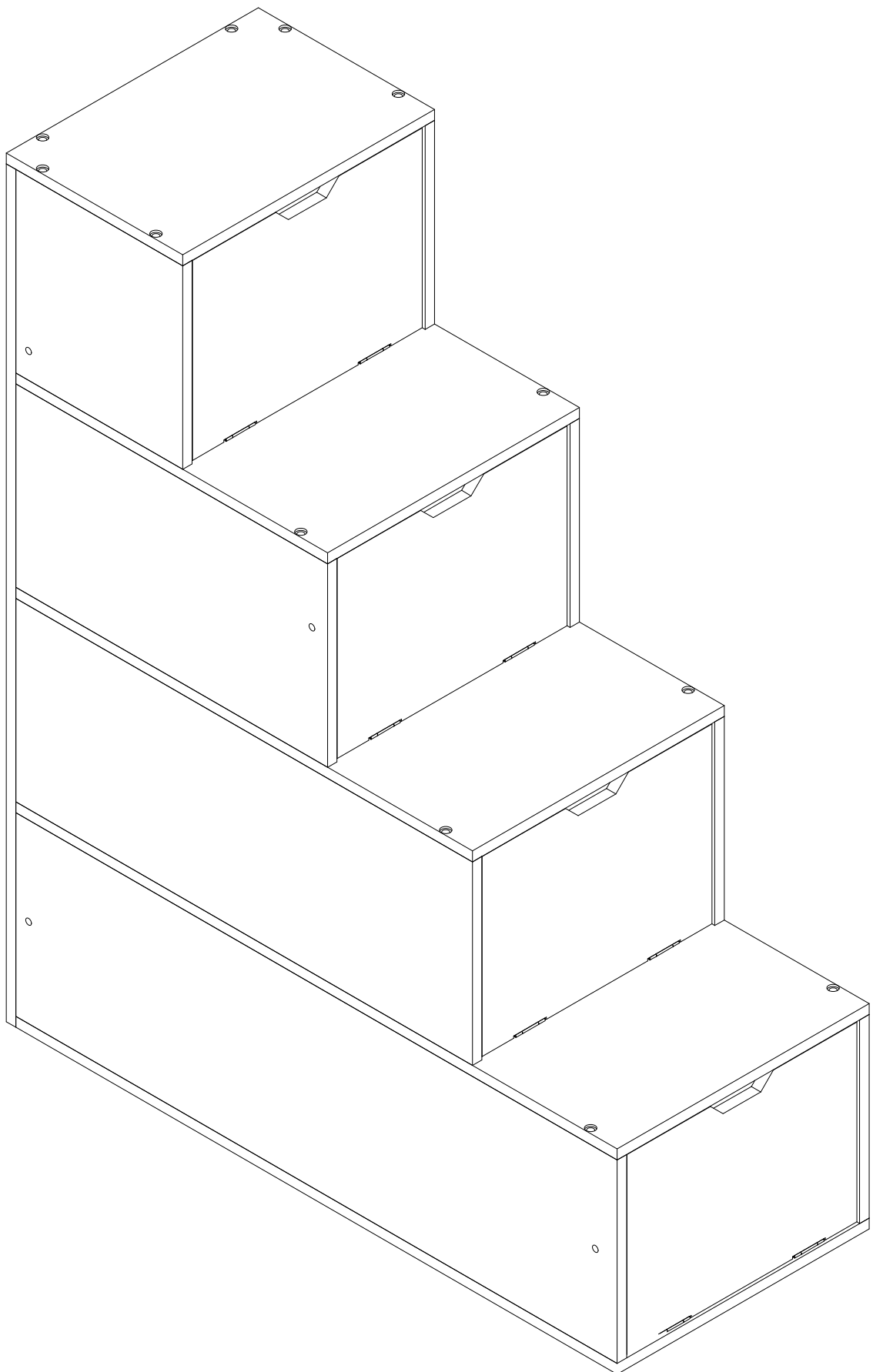

Schritt 4-9:



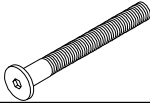

Schritt 5-1:

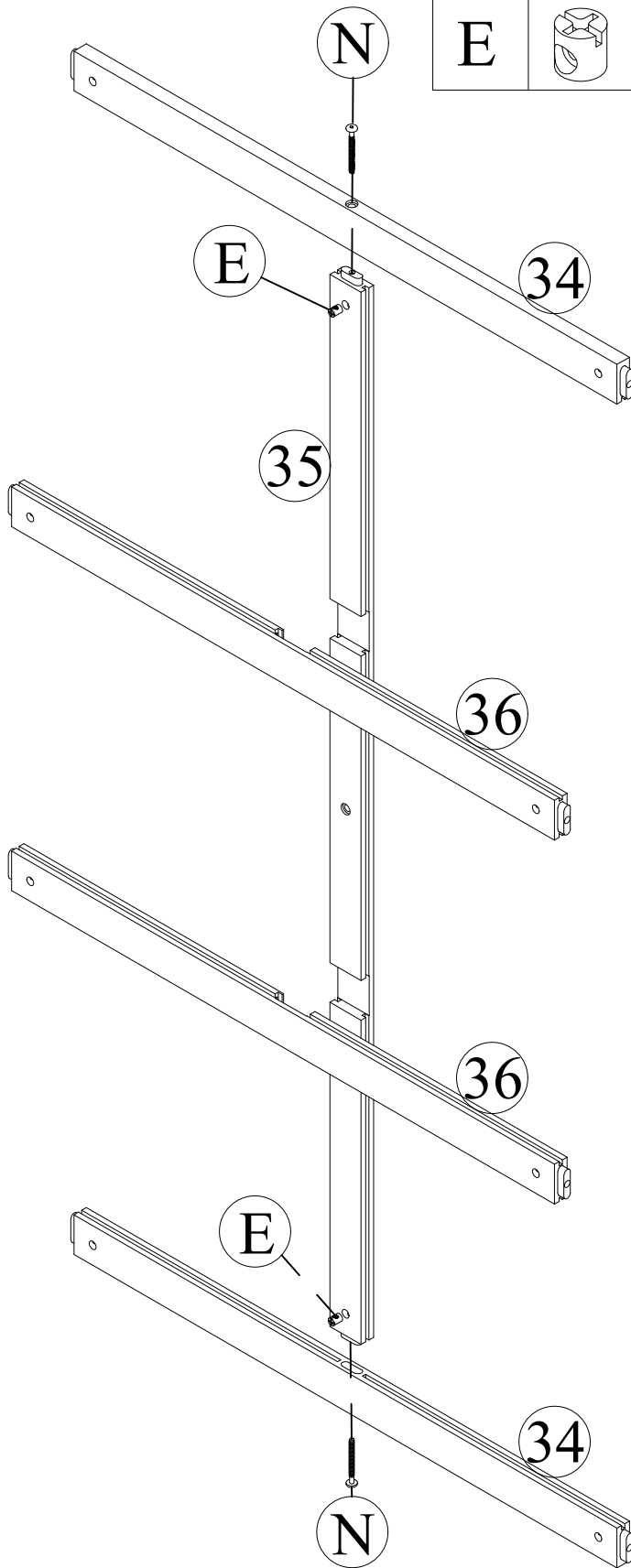
N		M6x100	2
E		M6x13	2

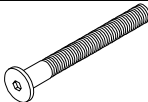

Schritt 5-2:

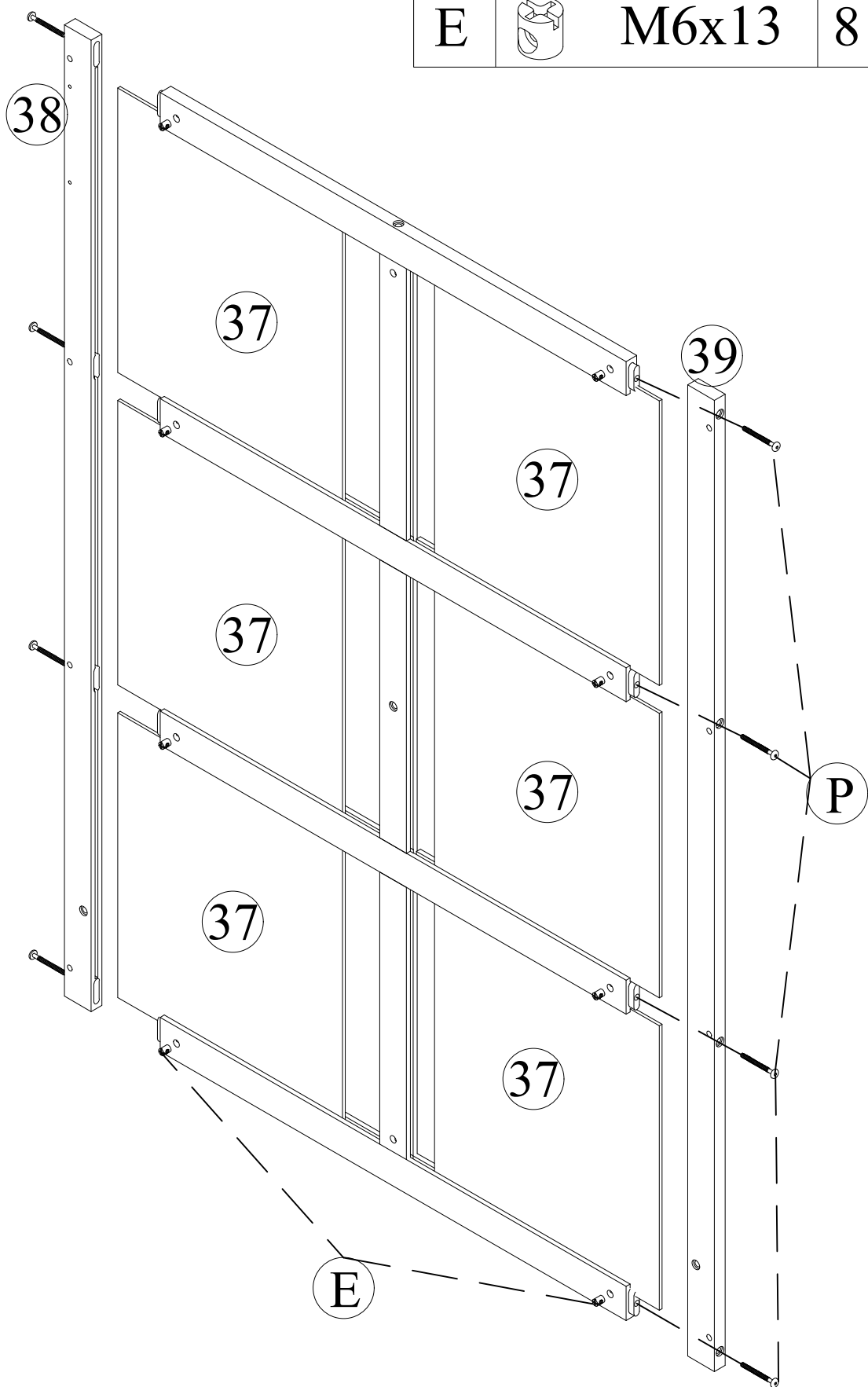

P		M6x100	8
E		M6x13	8

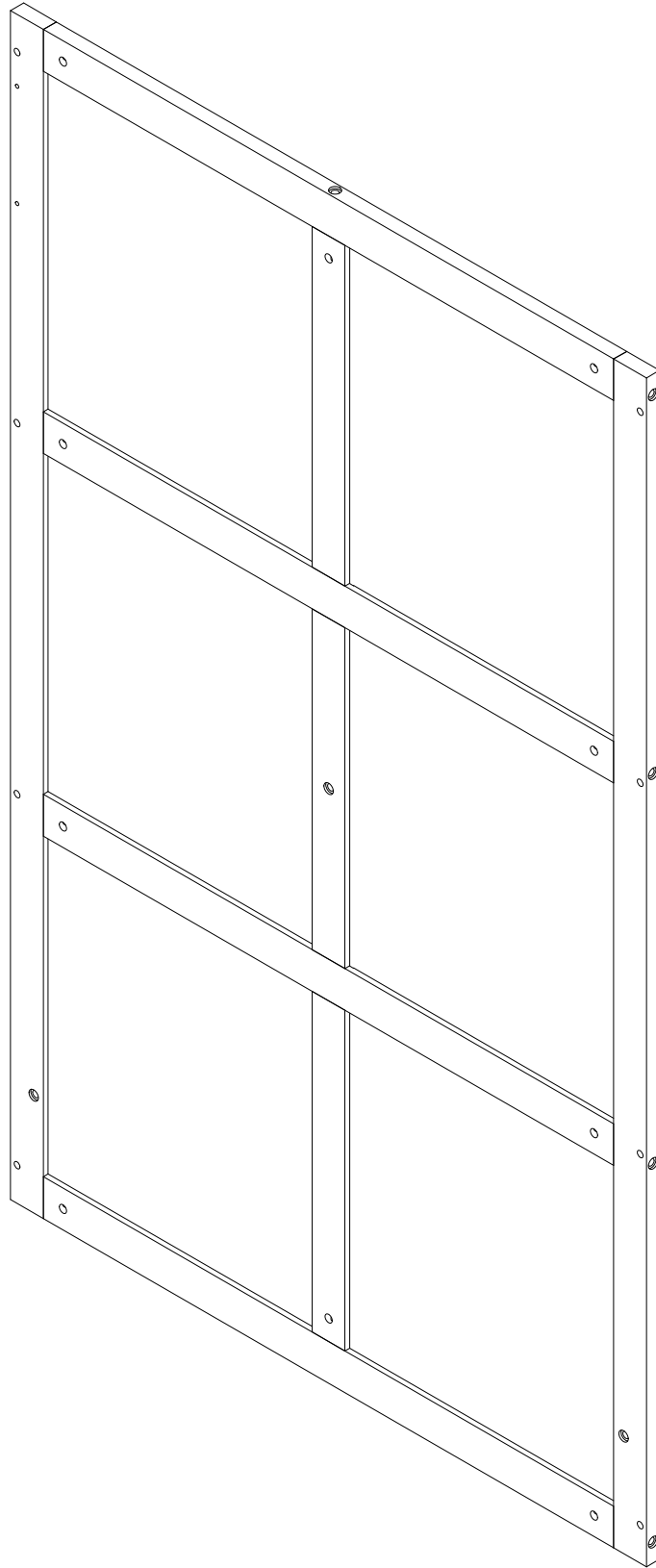

Schritt 5-3:

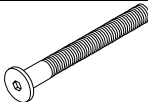

Schritt 5-4:

Q		M6x65	20
E		M6x13	20

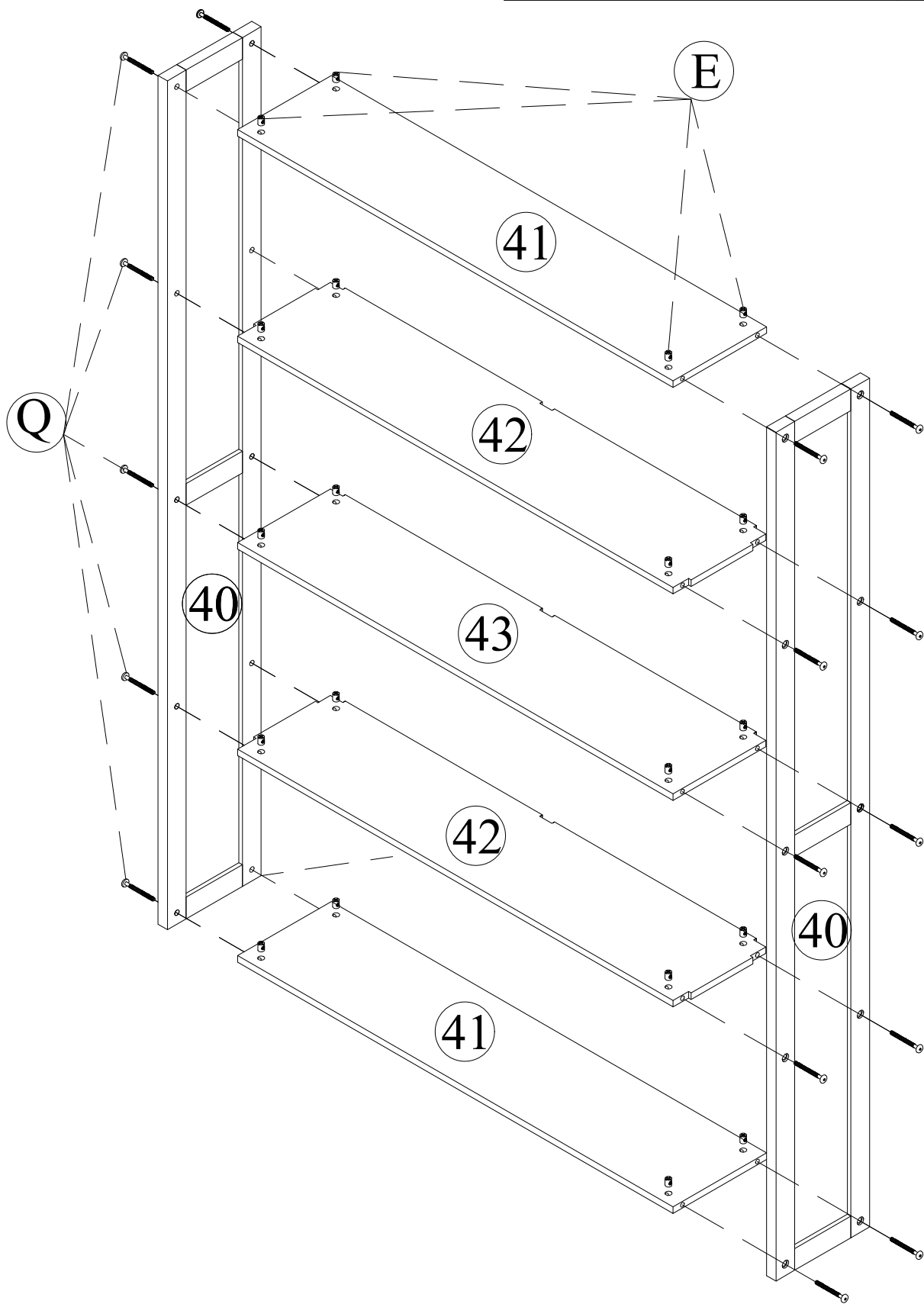

Schritt 5-5:

O

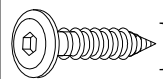

M6x40

8

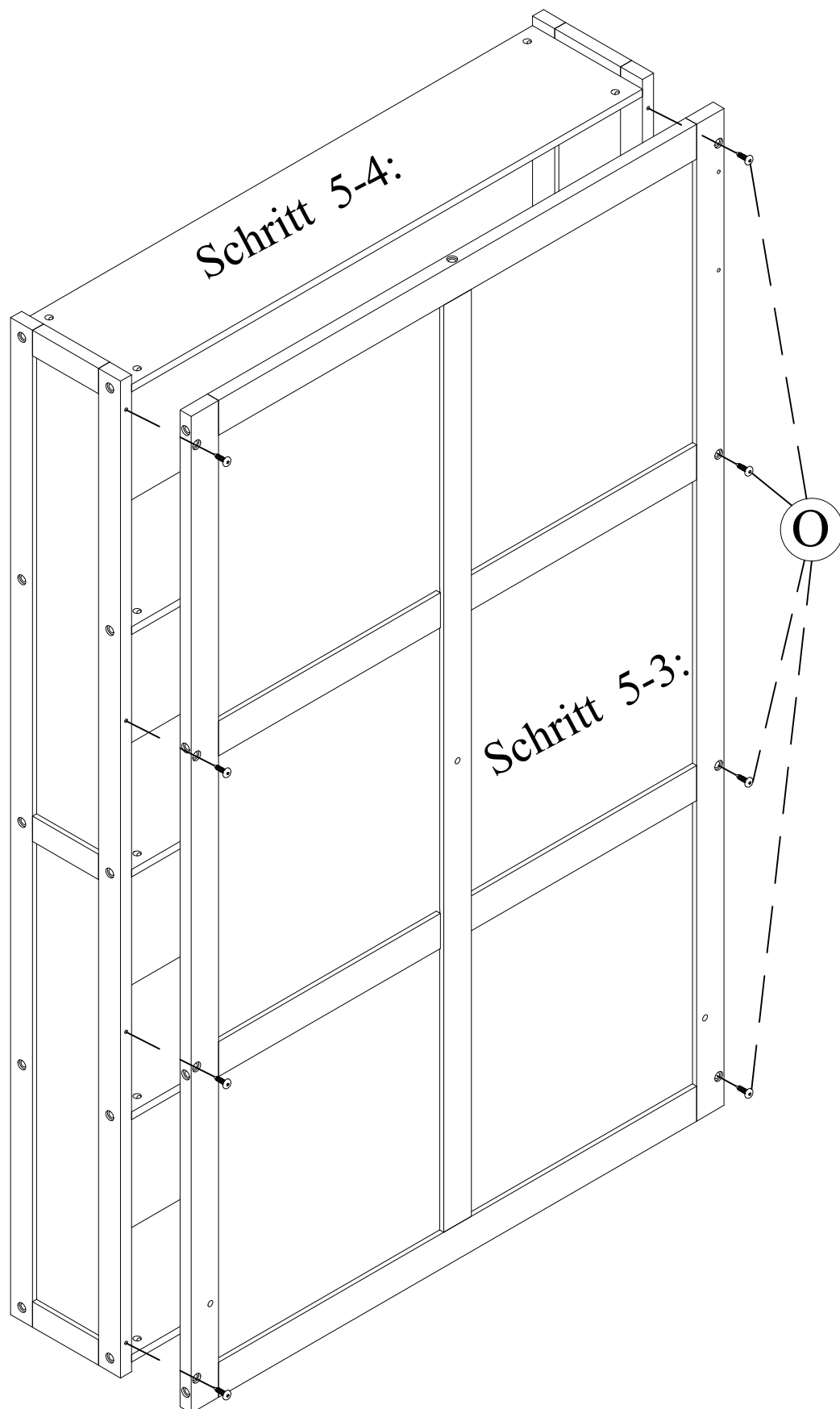

Schritt 6:

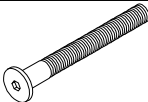
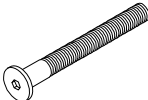
D		M6x75	2
T		M6x70	1

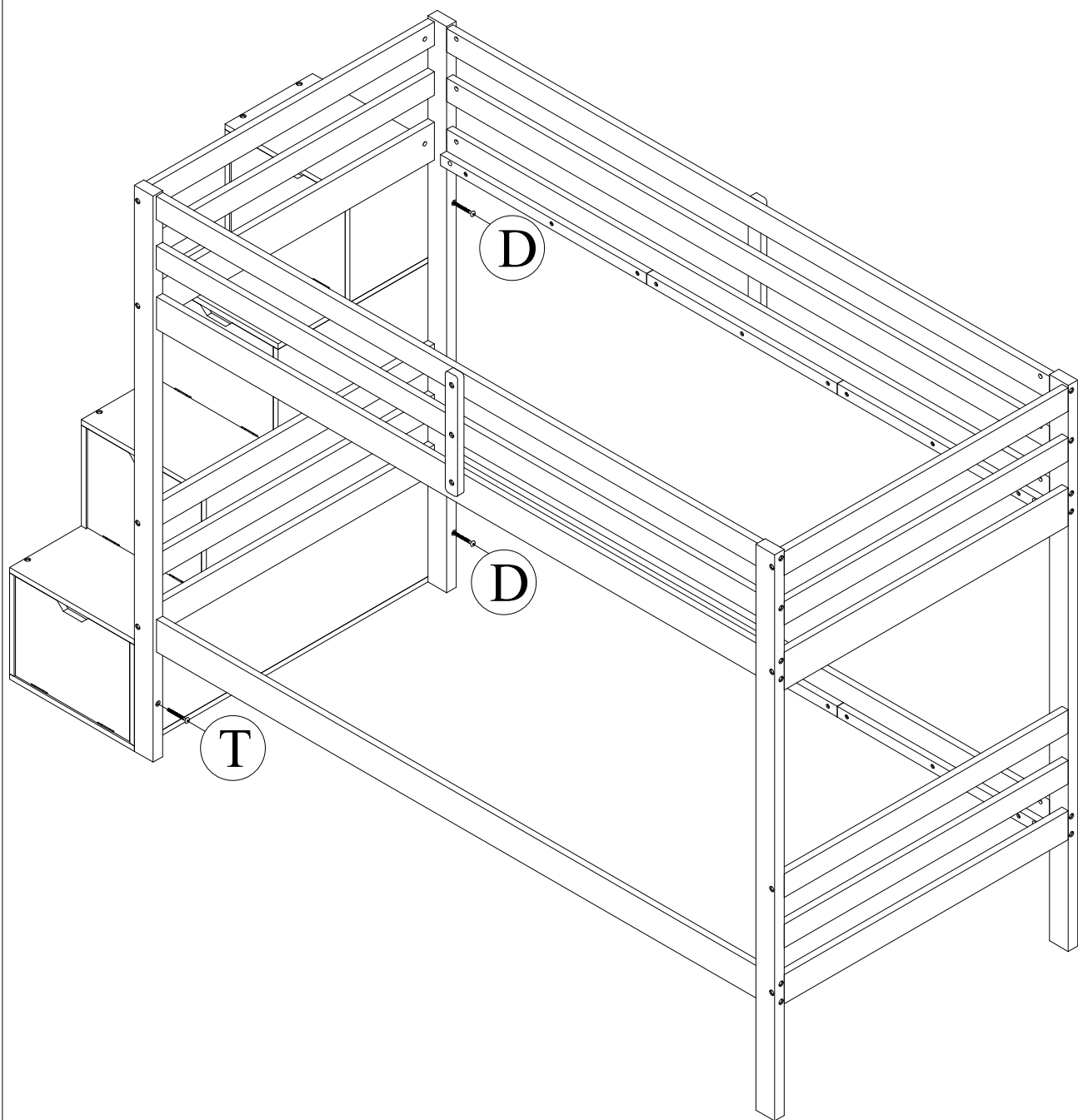

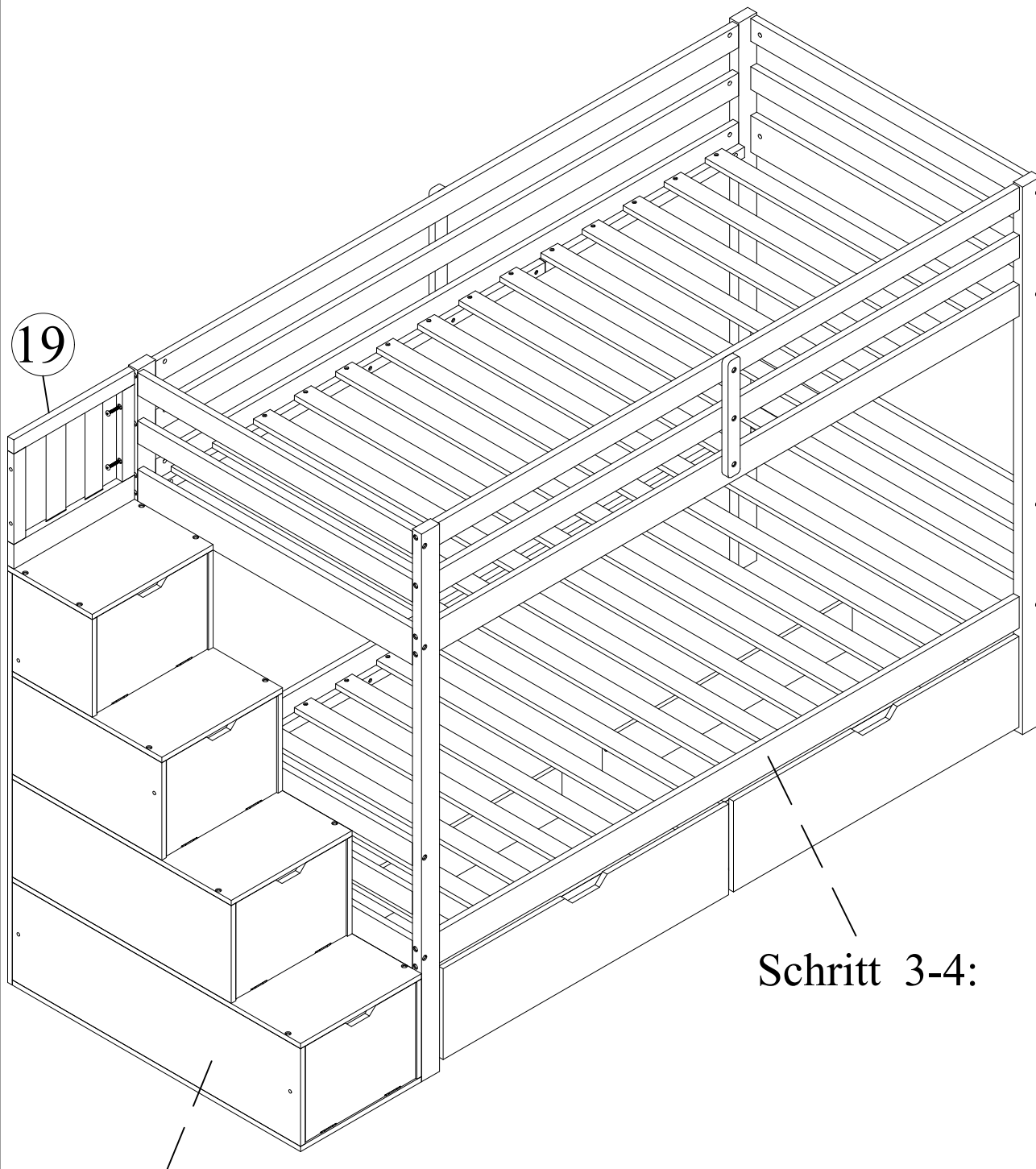

Schritt 7:



Schritt 4-10:

Schritt 3-4:

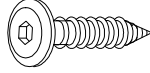
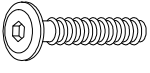
Schritt 8:

P		M6x60	4
J		M6x30	4
M		M3x12	5
R		2x14x30	5

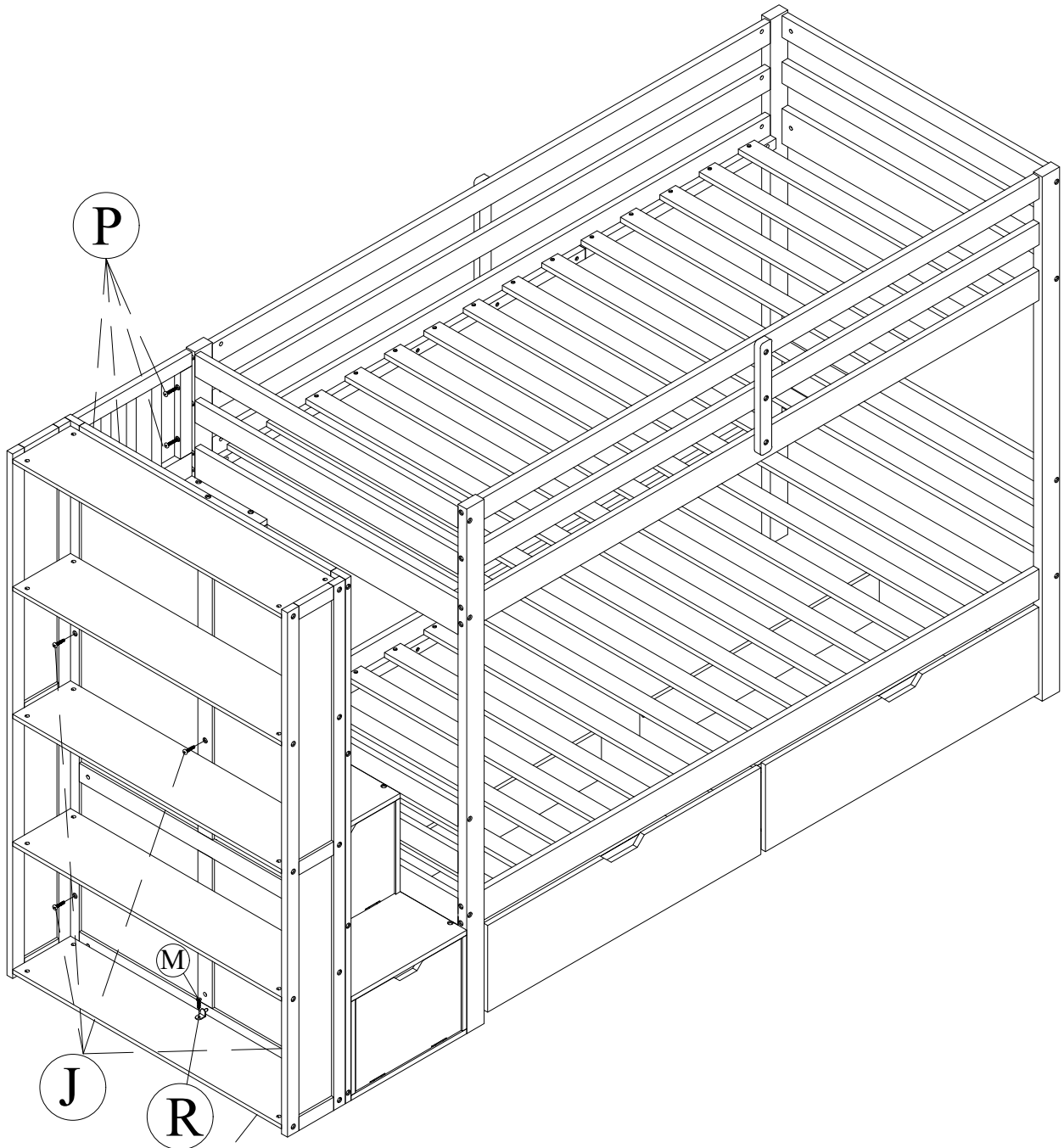

Schritt 5-5: