

ROCK

1826-131-35
 1826-131-48
 1826-131-49

131

D Unser Direktservice für Beschlaßteile
 Sollte Ihnen ein Beschlaßteil fehlen, können Sie diese Servicekarte direkt an die untenstehende Adresse mailen. Wir können allerdings nur Beschlaßteile auf diesem Wege verschicken. Sollten Sie eine andere Beanstandung an Ihrem Möbelstück haben, so wenden Sie sich bitte direkt an Ihr Möbelhaus.

GB Our direct order service for fitting
 If a fitting part is missing, you can e-mail this service card directly to the address below. However, we can only send fitting parts in this way. If you have any other cause for complaint concerning your item of furniture, please contact your furniture store directly.

CZ Naše přímé služby pro kování
 Chybí li vám nějaký díl z kování, můžete tuto servisní kartu odcloot e mailom přímo na níže uvedenou adresu. Touto cestou však můžeme zoselit jen díly kování. Pokud byste reklamovali jiný díl nábytku, obraťte se přímo na svého prodejce nábytku.

F Bien étudier la notice de montage
 S'il vous manque une ferrure, veuillez envoyer directement la présente carte service à l'adresse e-mail indiquée ci-dessous. Cependant, ceci nous permet uniquement d'envoyer des ferrures. Pour tout autre type de réclamation concernant votre meuble, veuillez contacter directement votre magasin d'ameublement.

I Il nostro servizio diretto per l'ordine della ferramenta
 Qualora Vi dovesse mancare un pezzo di fissaggio, allora Vi preghiamo di inviare questa carta di servizio immediatamente all'indirizzo sottostante. Possiamo inviare i pezzi di fissaggio solamente per mezzo di questo procedimento. Qualora dovete avere qualche altra reclamazione in merito al mobile, allora Vi preghiamo di rivolgerVi direttamente al Vostro Negozio di mobili.

BG Целева електронна услуга за обков
 Ако липсват части от комплекта, попълнете настоящата сервисна карта и ни изпратете на e-mail адреса, посочен по-долу. По този начин можем да доставим само липсващи елементи от обкова. Ако установите други дефекти по мебелите, Ви съветваме да се обърнете към мебелната къща/магазин, от който сте закупили стоката.

NL Onze directservice voor losse onderdelen
 Wanneer er een onderdeel ontbreekt, kunt u deze servicekaart direct aan onderstaand e-mailadres sturen. Wij kunnen langs deze weg echter alleen beslagdelen versturen. Mocht u een ander probleem aan uw meubel hebben, verzoeken wij u contact op te nemen met uw meubeldealer.

PL Nasz bezpośredni serwis części montażowych
 Jeżeli brakuje części koniecznych do montażu, prosimy o przesłanie nam niniejszej karty serwisowej na niżej podany adres e-mailowy. W ten sposób możemy przesłać Państwu tylko brakujące części. W przypadku innych reklamacji dotyczących mebla, prosimy zgłosić się do salonu meblowego, w którym został dokonany zakup.

HR Servis za okove
 U slučaju da nedostaje neki od dijelova molimo vas da na dolje navedenu mail adresu pošaljete ovaj servisni obrazac. Na ovaj način mogu do dobiti samo okovi. U slučaju da imate dodatne prigovore vezane uz komad namještaja molimo vas da se obratite izravno trgovini namještaja odjije je isti kupljen.

HU Direktszolgáltatunk vasalatok esetén
 Ha hiányzik egy vasalék, ezt a kártyát közvetlenül elküldheti az alább található címre. Azonban csak vasalatként tudunk így küldeni. Amennyiben másféle reklamáció áll fenn bútordarabjait illetően, forduljon közvetlenül a bolti ruhához.

SK Naš priamy servis pre časti kovania
 Ak by Vám chýbala nejaká časť kovania, môžete poslať túto servisnú kartu priamo e-mailom na nižšie uvedenú adresu. Diely kovania vieme poslať iba týmto spôsobom. Ak by ste mali inú reklamáciu ohľadom Vášho nábytku, obráťte sa priamo na Vašu predajňu nábytku.

SLO Naše direktne uslužne storitve za okovje
 Če vam manjka kakšno okovje, lahko to servisno kartico pošljete po e-pošti direktno na spodnji naslov. Po tej poti vam lahko pošljemo samo okovje. Če želite reklamirati kakšen drug del pohištva, se obrnite neposredno na vašo trgovino pohištva.

RO Service-ul nostru direct pentru feronerie
 In cazul in care va lipseste o piesa de feronerie puteti sa trimiteti direct acest card de service prin e-mail la adresa de mai jos. Noi nu putem expedia piese de feronerie decat pe acestă cale. Dacă aveți o altă reclamație referitoare la piesa de mobilier, atunci vă rugăm să vă adresați direct la magazinul dvs. de mobilier.

RUS Наш прямой сервис для поставок фурнитуры
 Если окажется, что Вам не хватает того или иного элемента фурнитуры, Вы можете отправить сервисную карту по факсу непосредственно на нижеуказанный адрес электронной почты. Однако, таким образом мы можем переслать лишь фурнитуру. Если же у Вас возникнут иные претензии относительно приобретенной мебели, пожалуйста, обращайтесь непосредственно в организацию, существовавшую продавцу.

S Vår direktservice för beslagsdelar
 Om du saknar en beslagsdel kan du skicka detta servicekort direkt till e-postadressen som anges nedan. Tänkt på att detta är den enda möjligheten att skicka beslagsdelar till dig. Om du vill reklamera din möbel av en annan anledning måste du kontakta ditt möbelhus direkt.

ES Nuestro servicio directo para accesorios
 Si le falta algún accesorio, puede enviar esta tarjeta de servicio directamente a la siguiente dirección. No obstante, por este método solo podemos enviar accesorios. Si tiene alguna otra objeción sobre su mueble, consulte directamente con su mueblería.

TR Donatılar için doğrudan servisimiz
 Bir donatınız eksikse bu servis kartını doğrudan aşağıda bulunan adrese doğrudan mail yazabilirsiniz. Sadece bu yolla donatılar gönderilebilir. Mobilyanızda başka şikayetleriniz varsa lütfen doğrudan mobilya satıcınıza danışın.

⑥, ⑦, ⑧ = max. 5kg

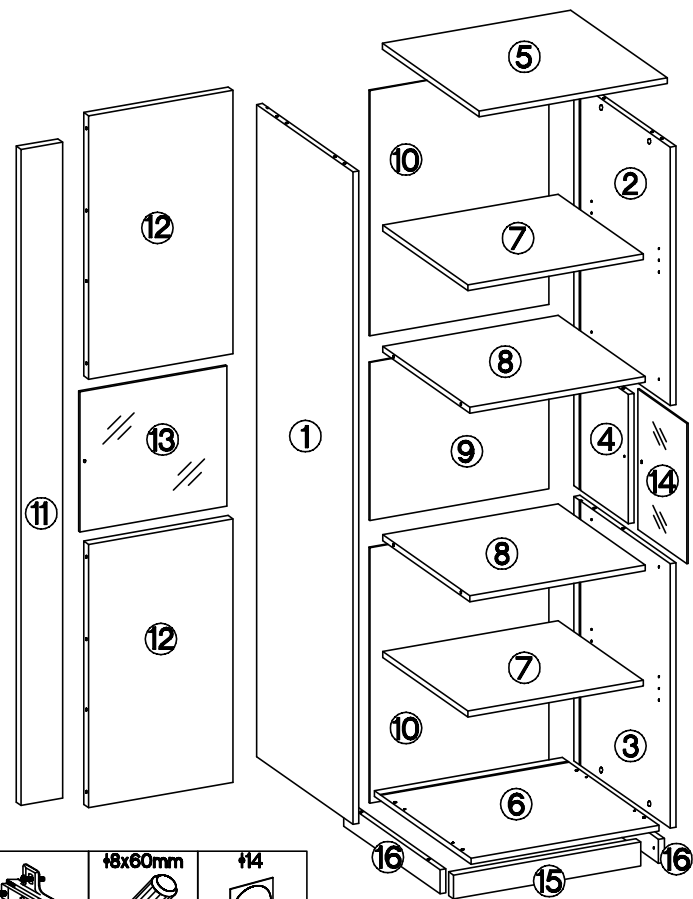

O7	L9														
1	1	G	P5	H	A2	E13									
L-192mm	L-4.0x27mm	L	L2	P1	T3	J24	P7	F4							
1	2	14	8	4	2	6	8	6							
D2	C	A	E	R11	J7	J3	O11								
16	16	12	16	2	2	8	1								

LKZ 80106

Grund der Beanstandung / Reason of the objection:

Möbelhaus / Furniture store:

Name / Name: _____ Telefon / Telephone: _____

PLZ / postal code: _____ Ort / City: _____

Strasse / Street: _____

Haus-Nr. / House No.: _____ @E-Mail: _____

1

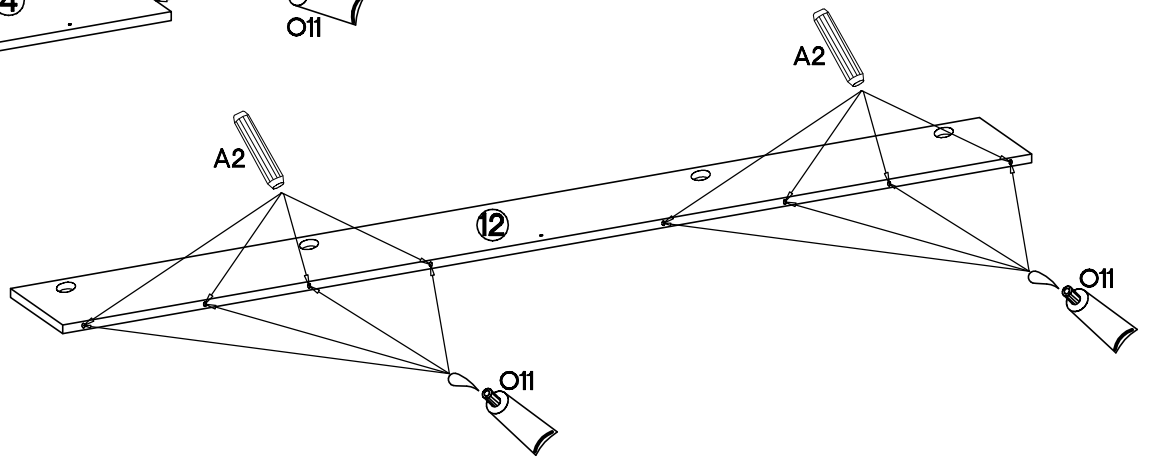
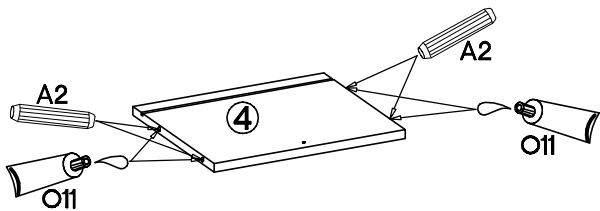

0,05 Loctite O11 1	#8x60mm A2 12
-----------------------------	---------------------

2

0,05 Loctite O11 1

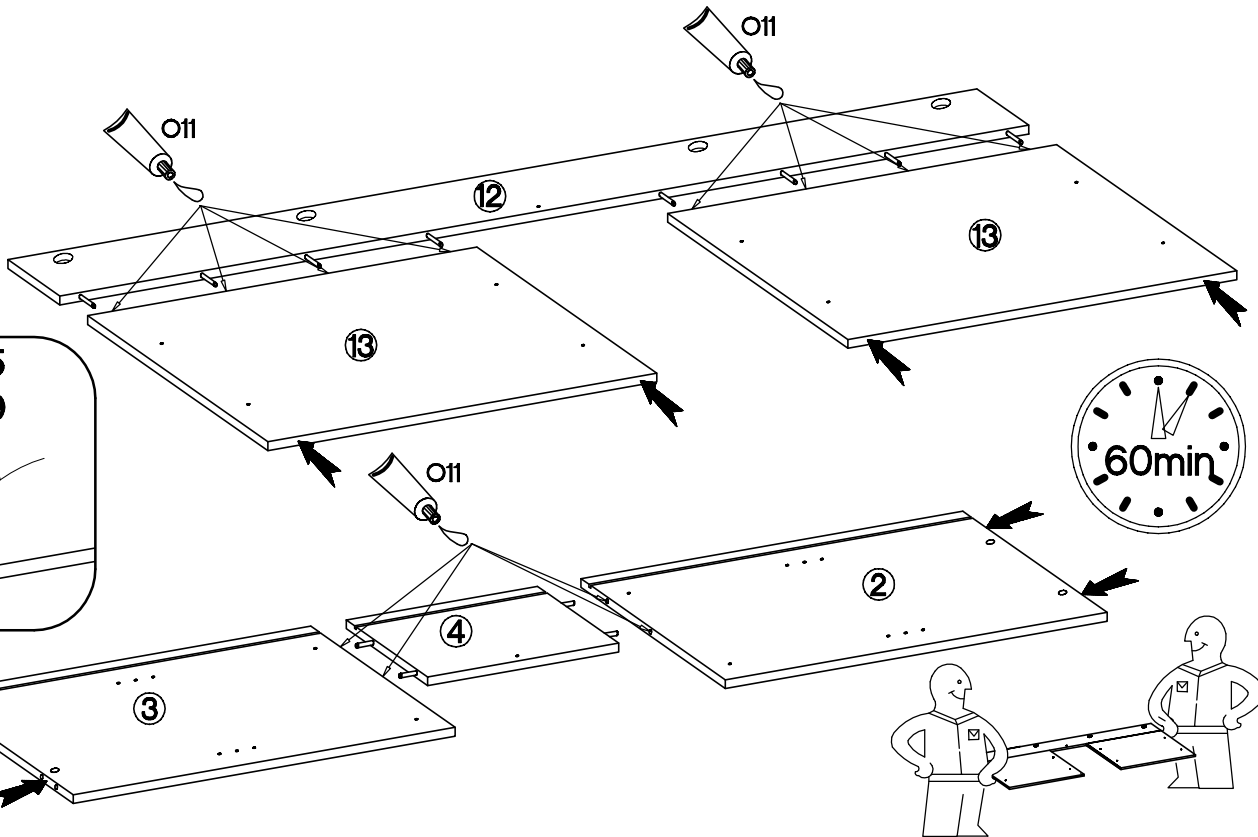

1826-131-35
1826-131-49



60min

3

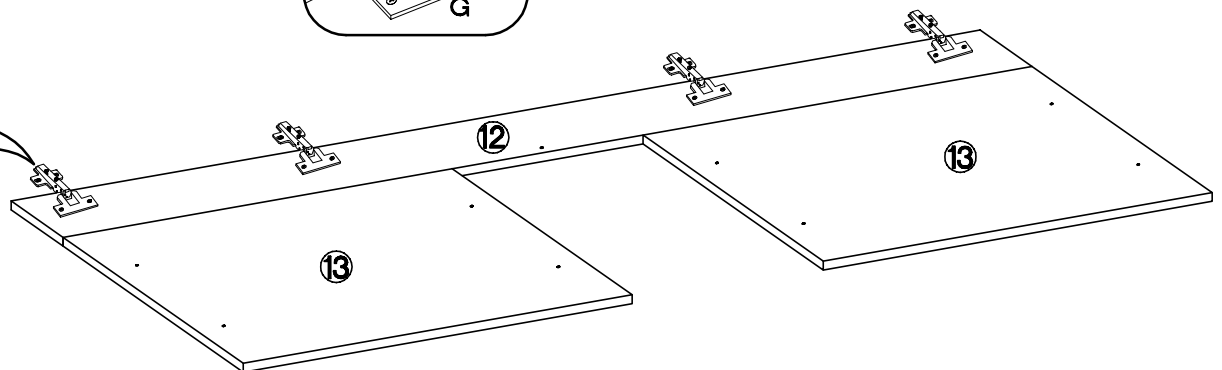
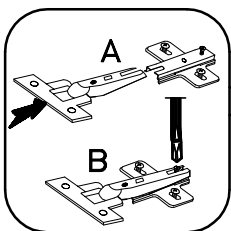
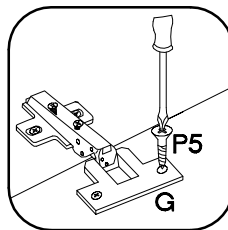
#35/0mm G 4	#3.5x13mm P5 8	H 4
-------------------	----------------------	--------







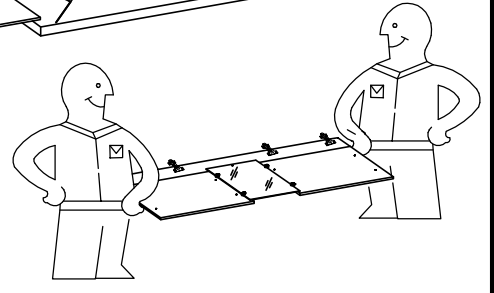
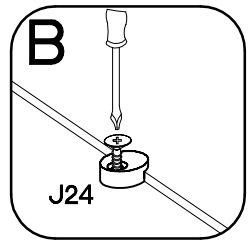
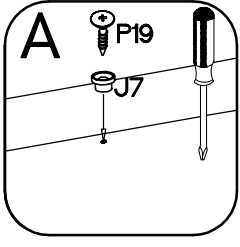
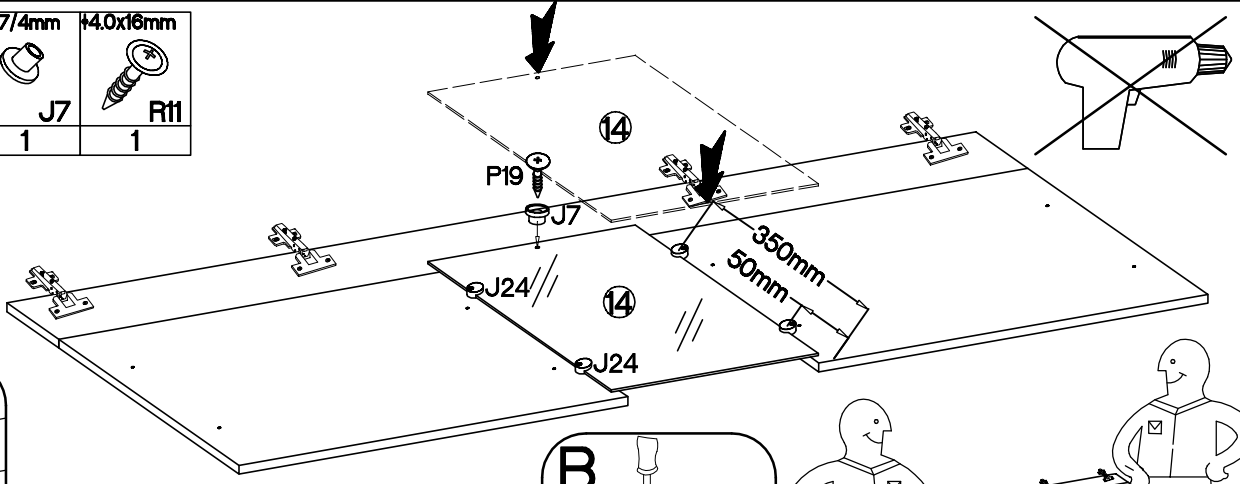

4

		
J24	J7	R11
4	1	1



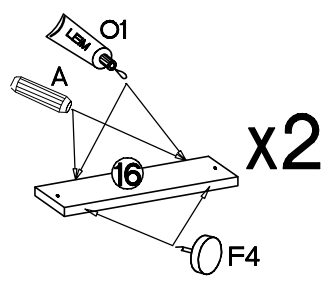
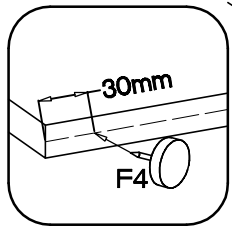
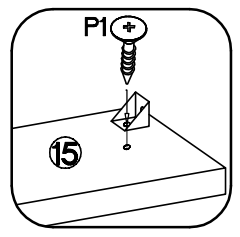
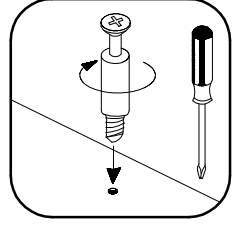
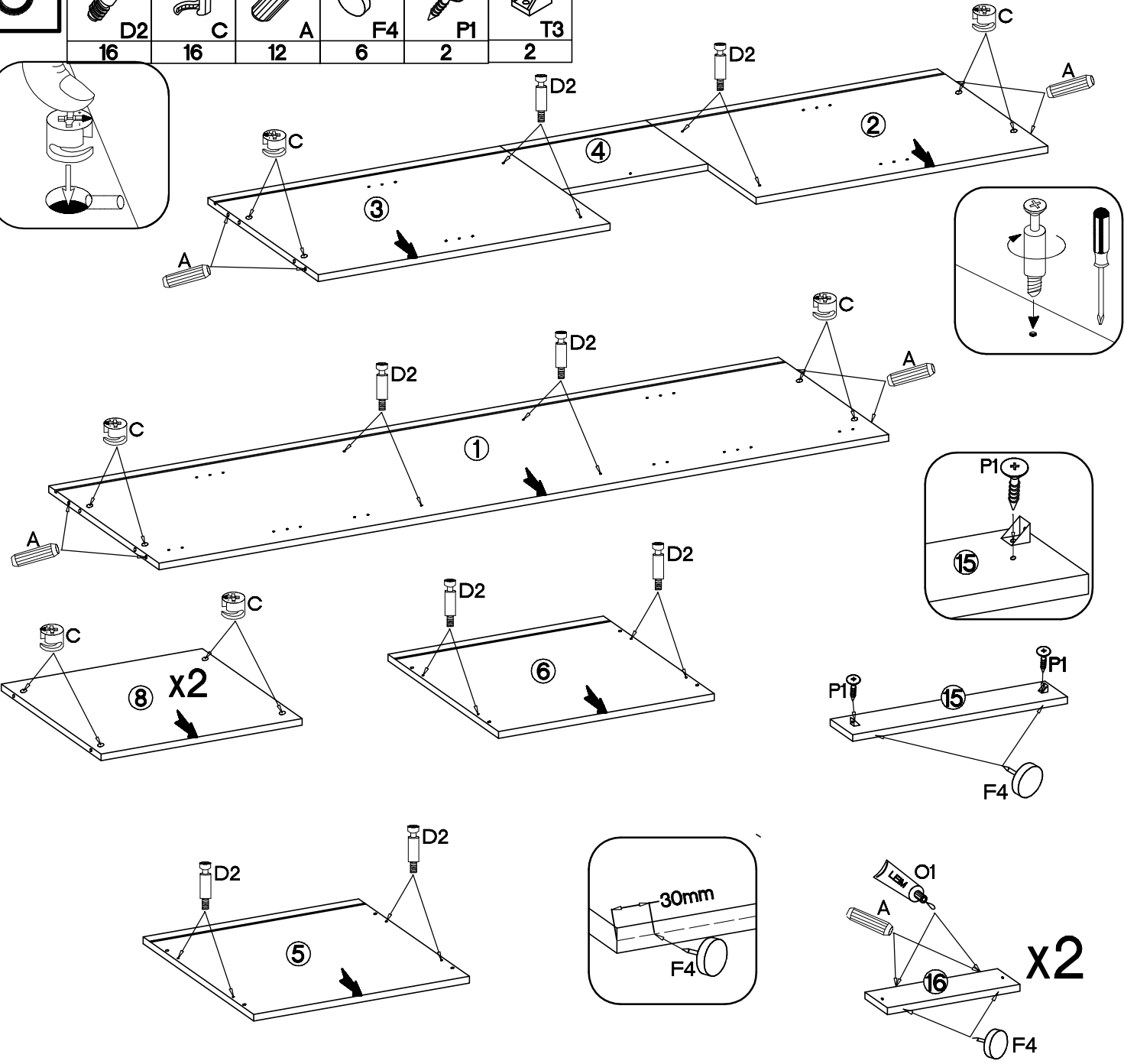
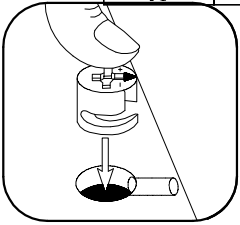

5

					
D2	C	A	F4	P1	T3
16	16	12	6	2	2



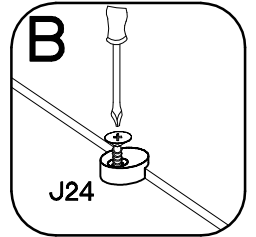
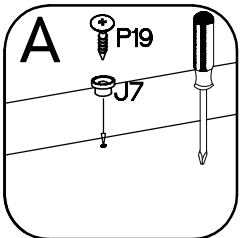
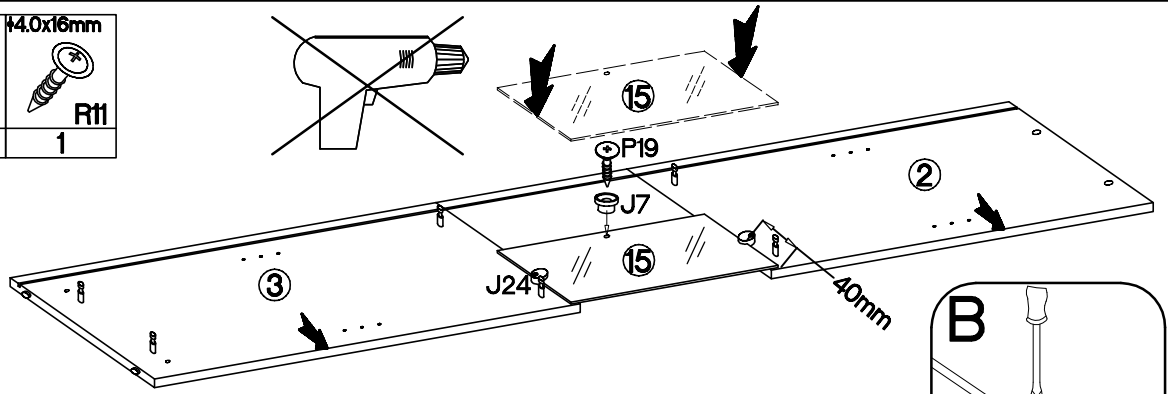
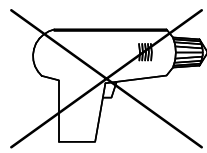

6

 J24 2	 J7 1	 P11 1
--	---	--



7

 P1 2	 O11 1
---	---

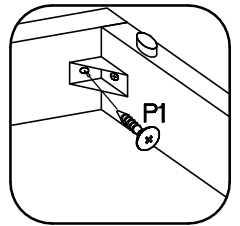
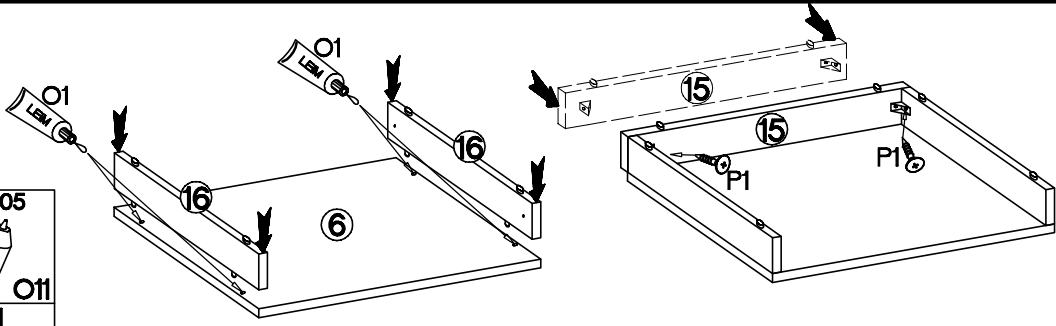

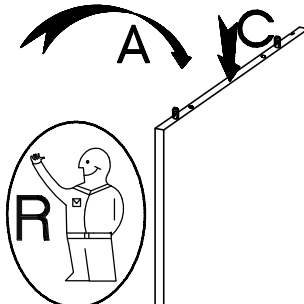
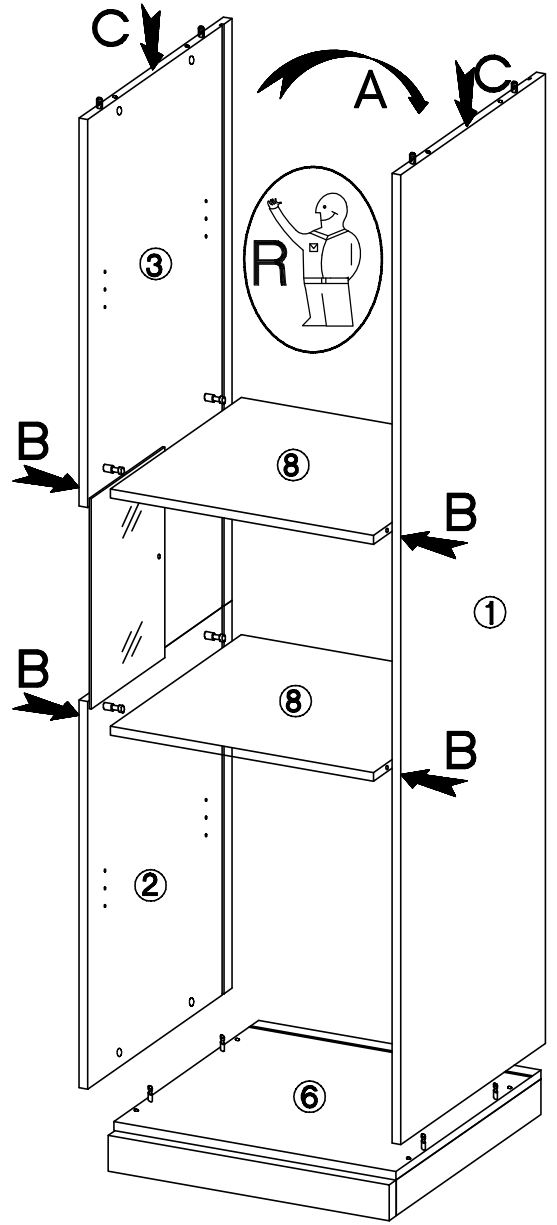
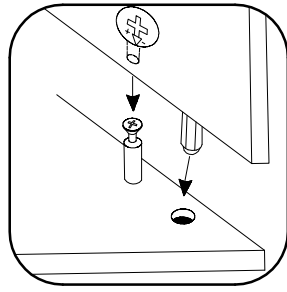
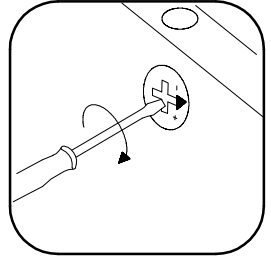
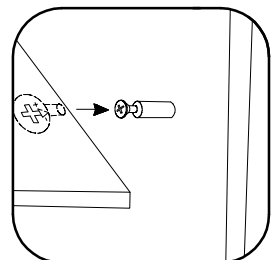
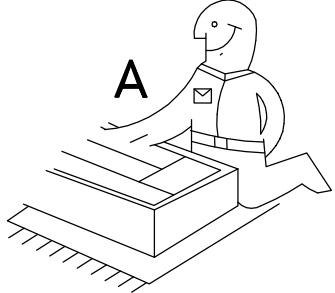
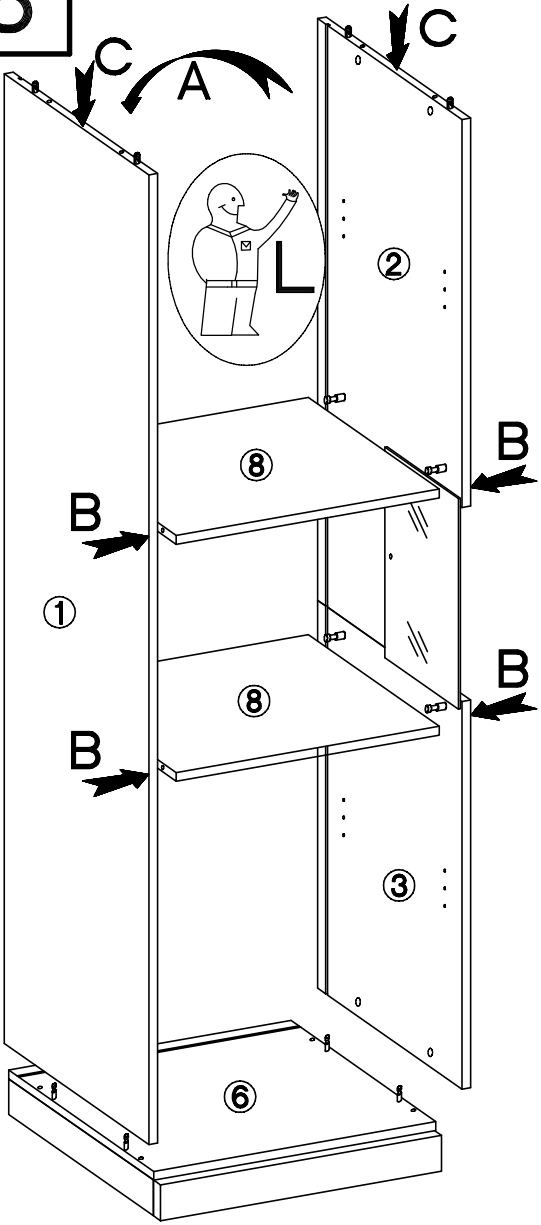

8

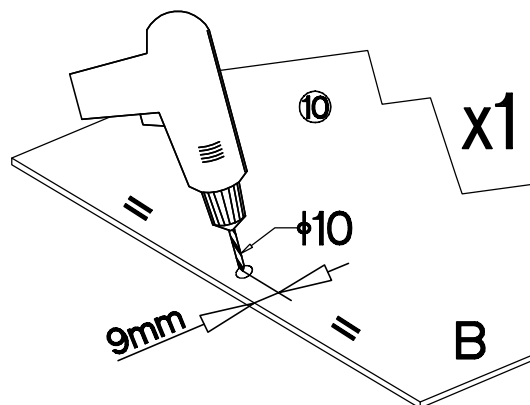
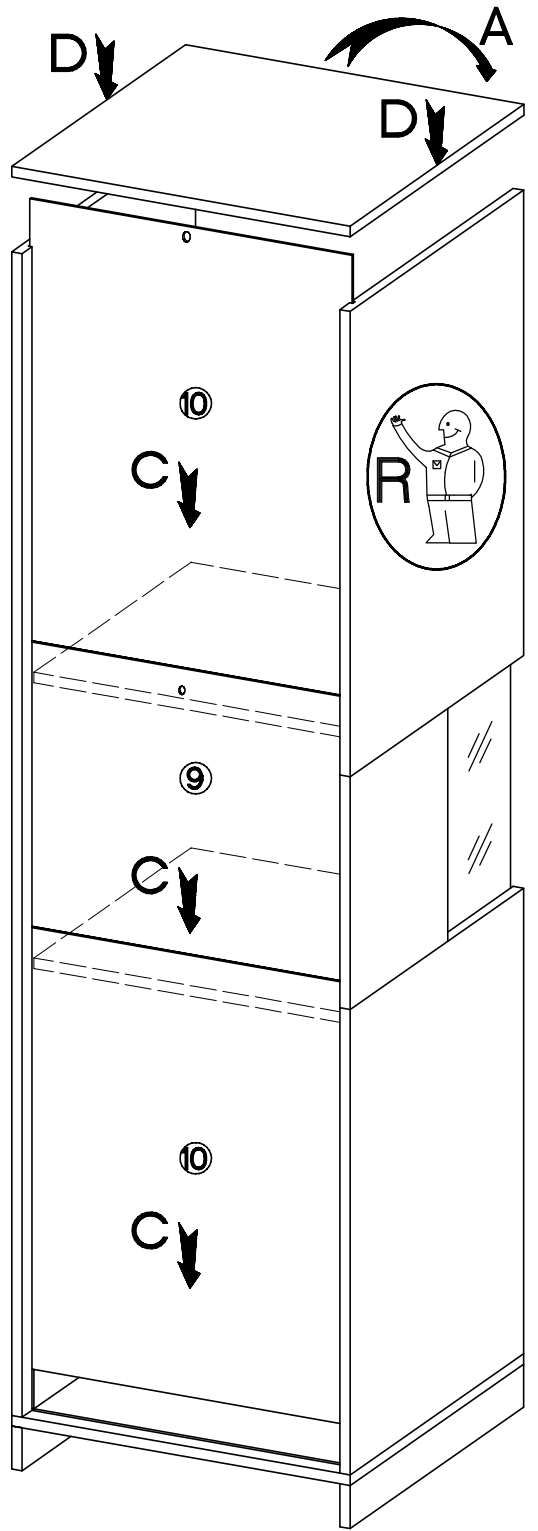
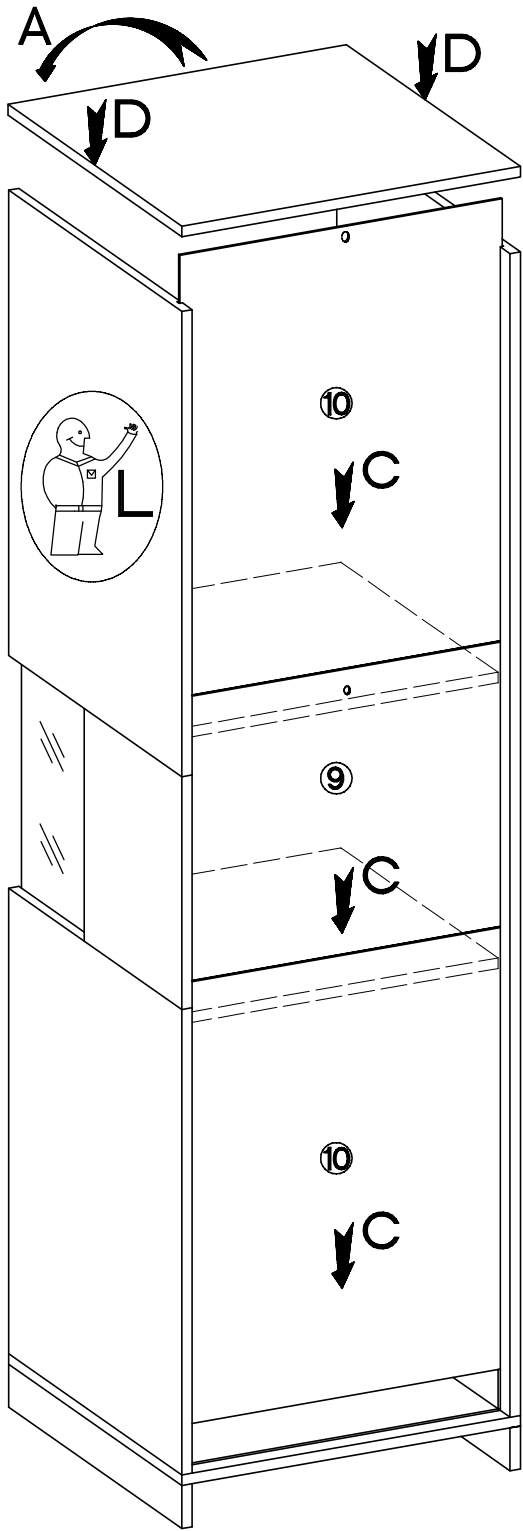

8



9

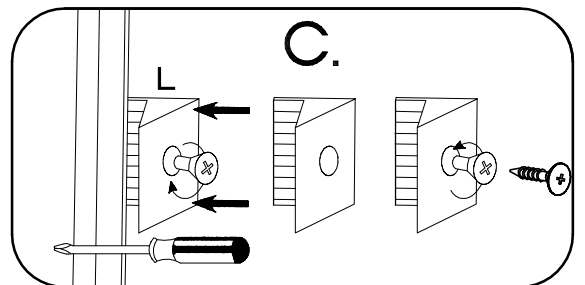
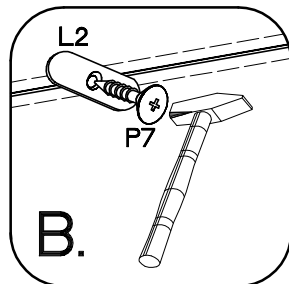
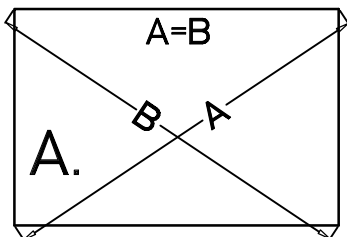
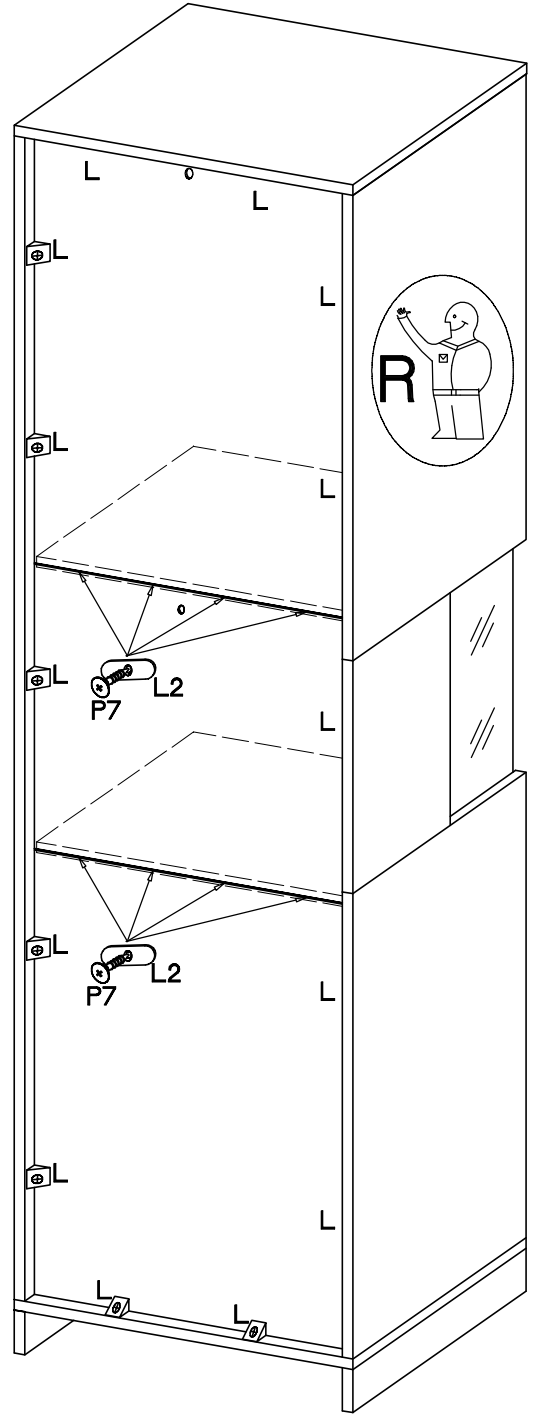
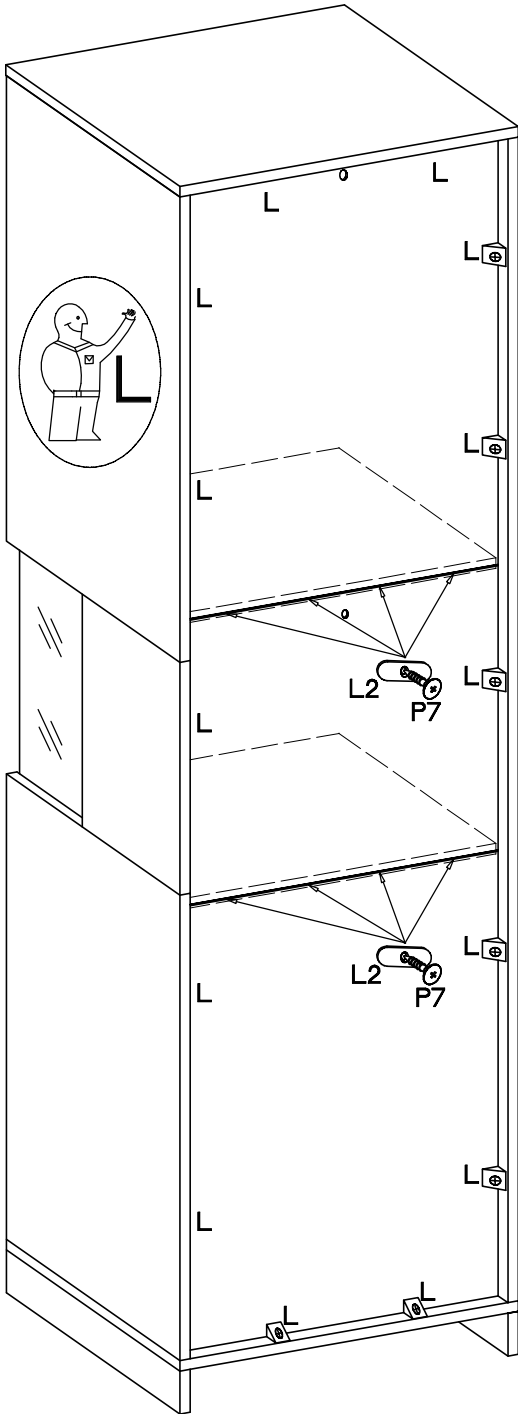

		
L2	P7	L
8	8	14

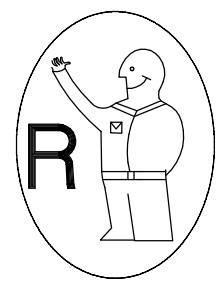
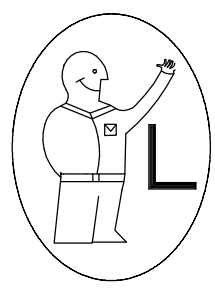
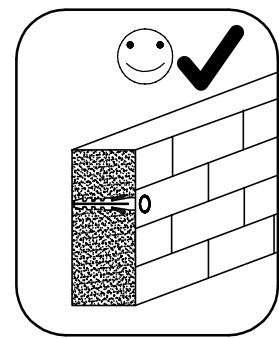
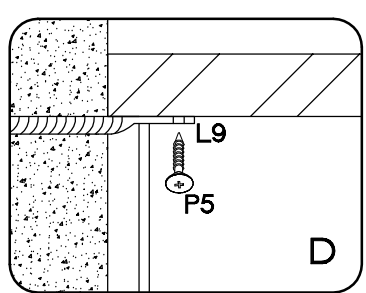
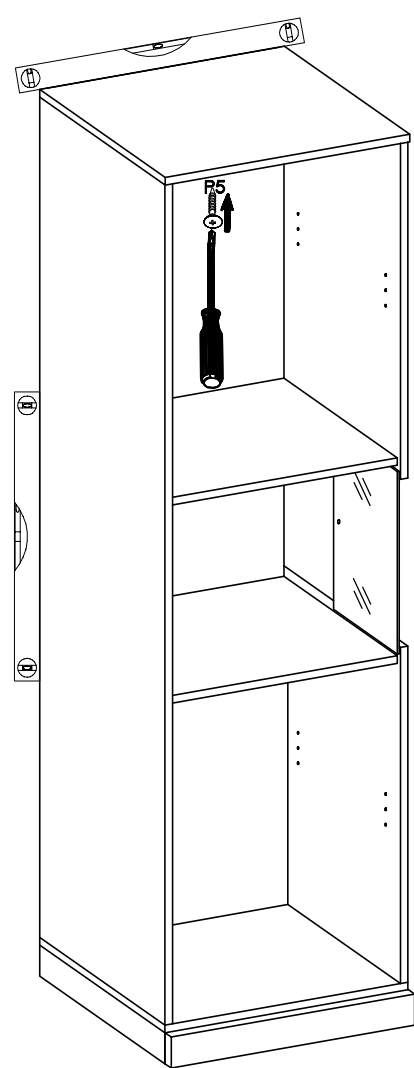
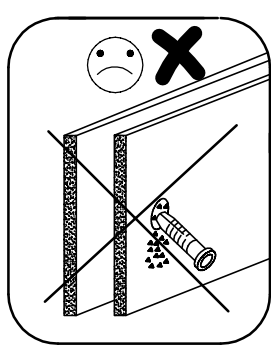
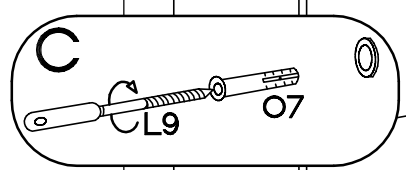
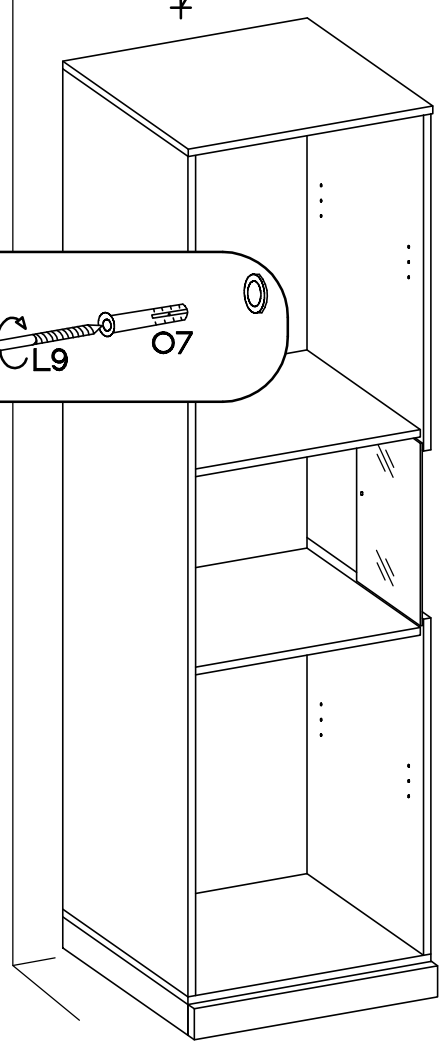
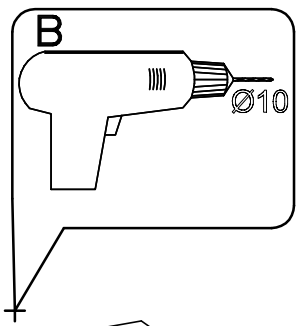
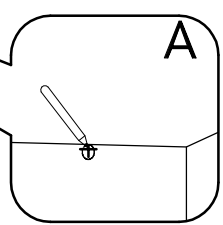
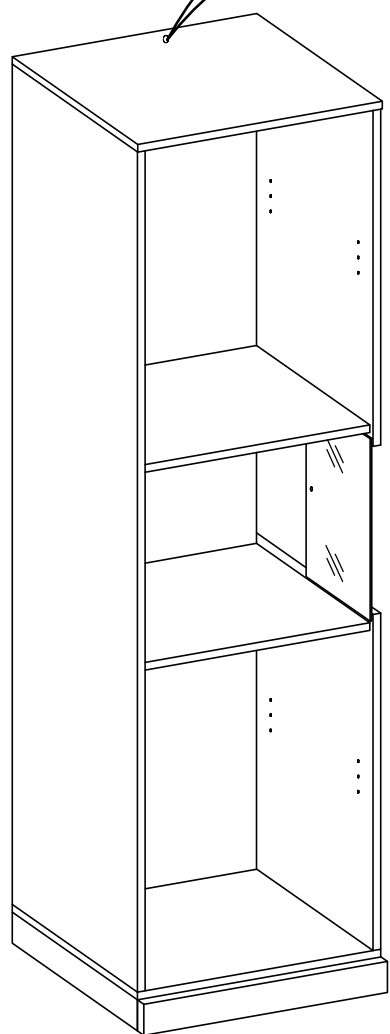



Ø10x50mm	Ø3.5x13mm	
O7	L9	P5
1	1	1

11

L=192mm	4.0x27mm
	
S17	R1
1	2

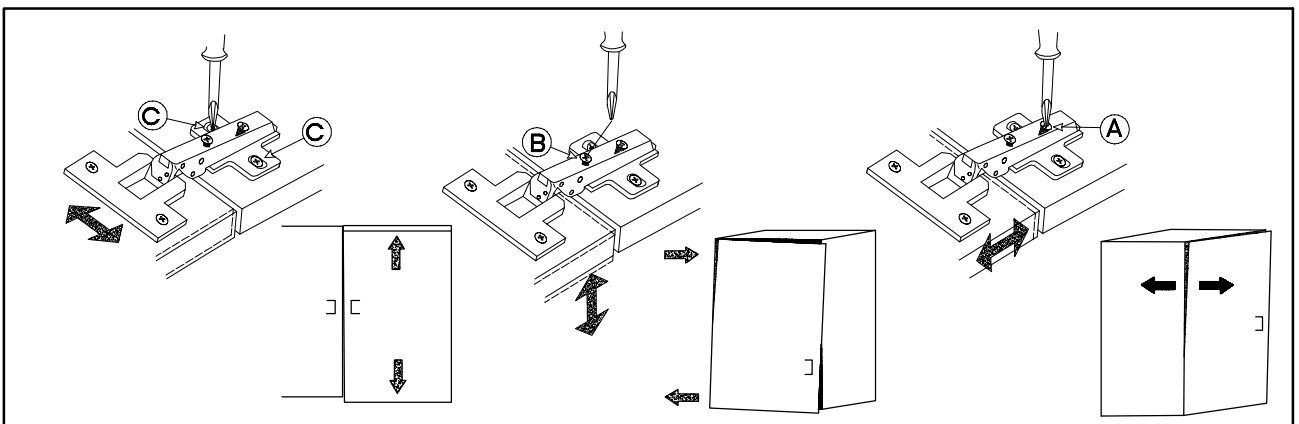
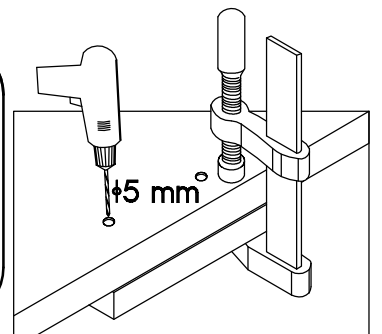
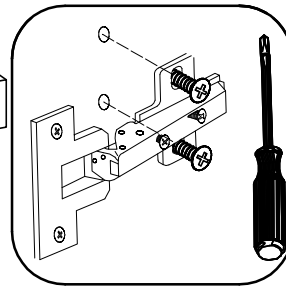
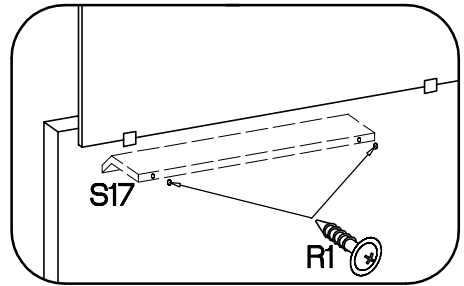
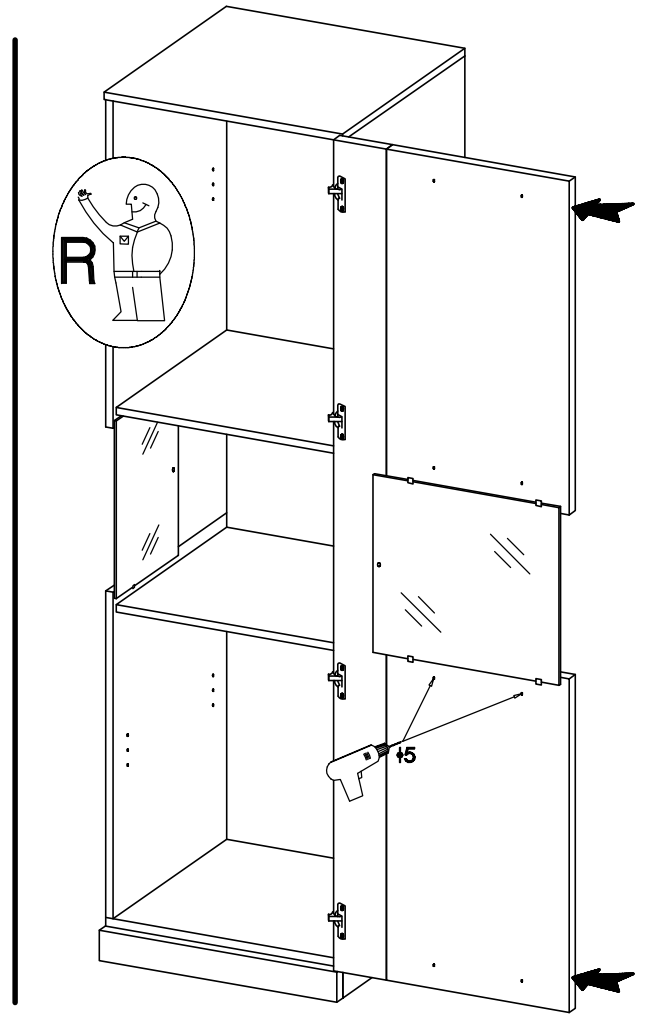
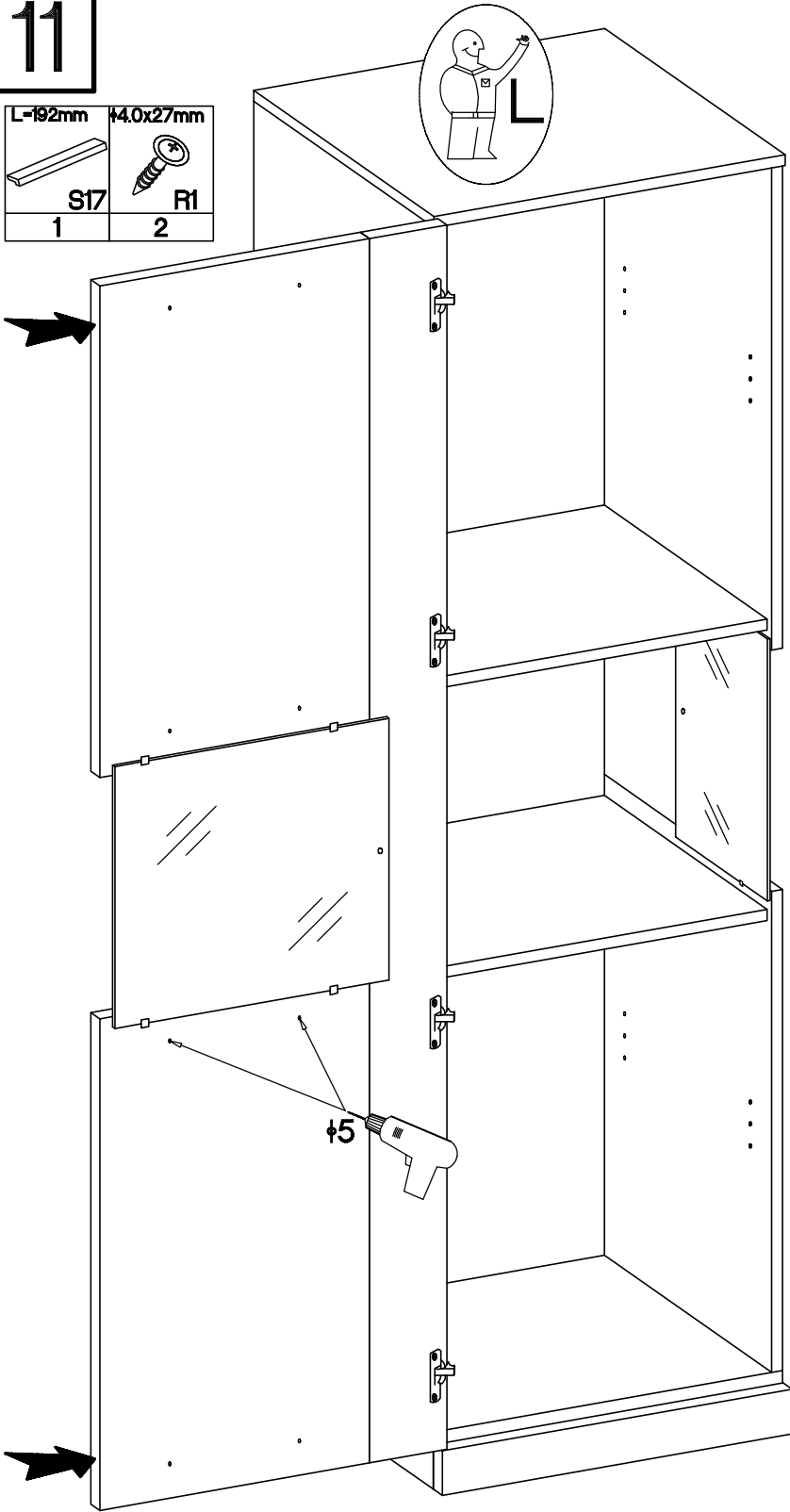

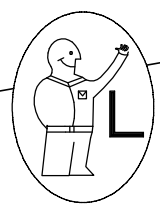

#4 E13	E	J3
1	16	8

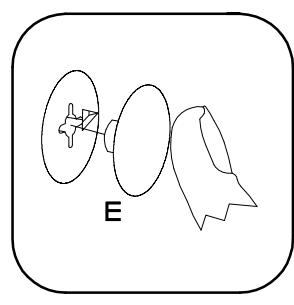
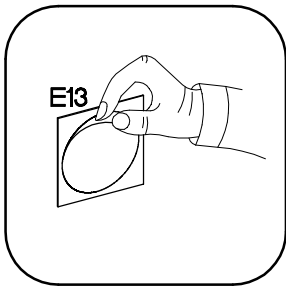
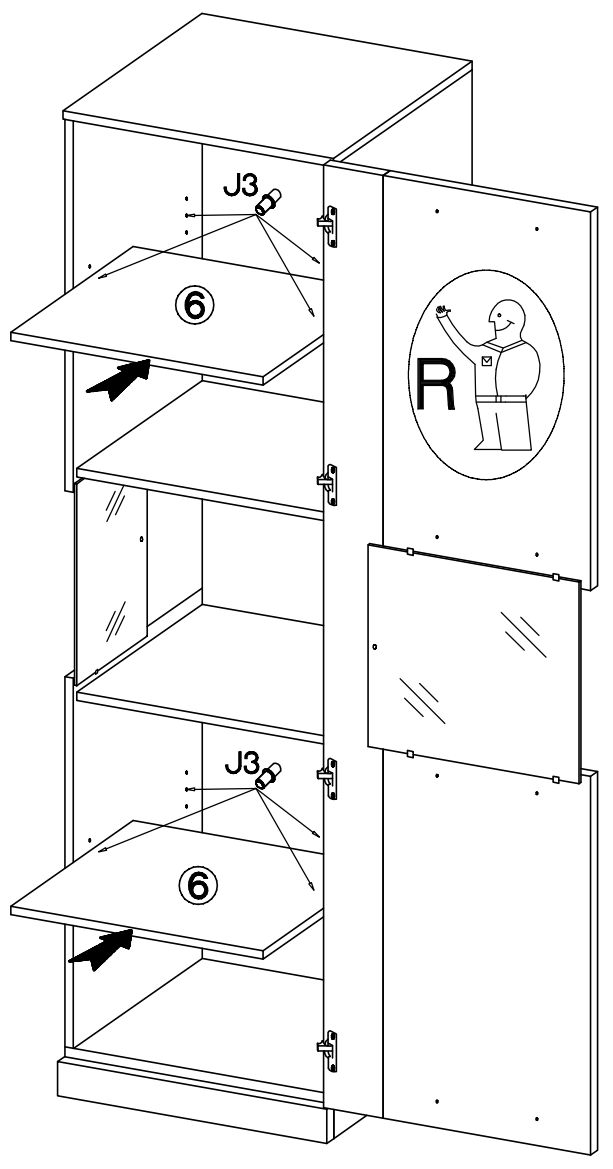
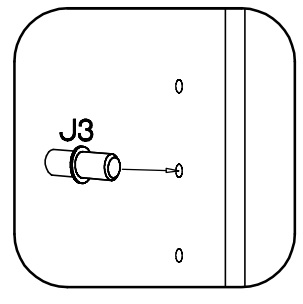
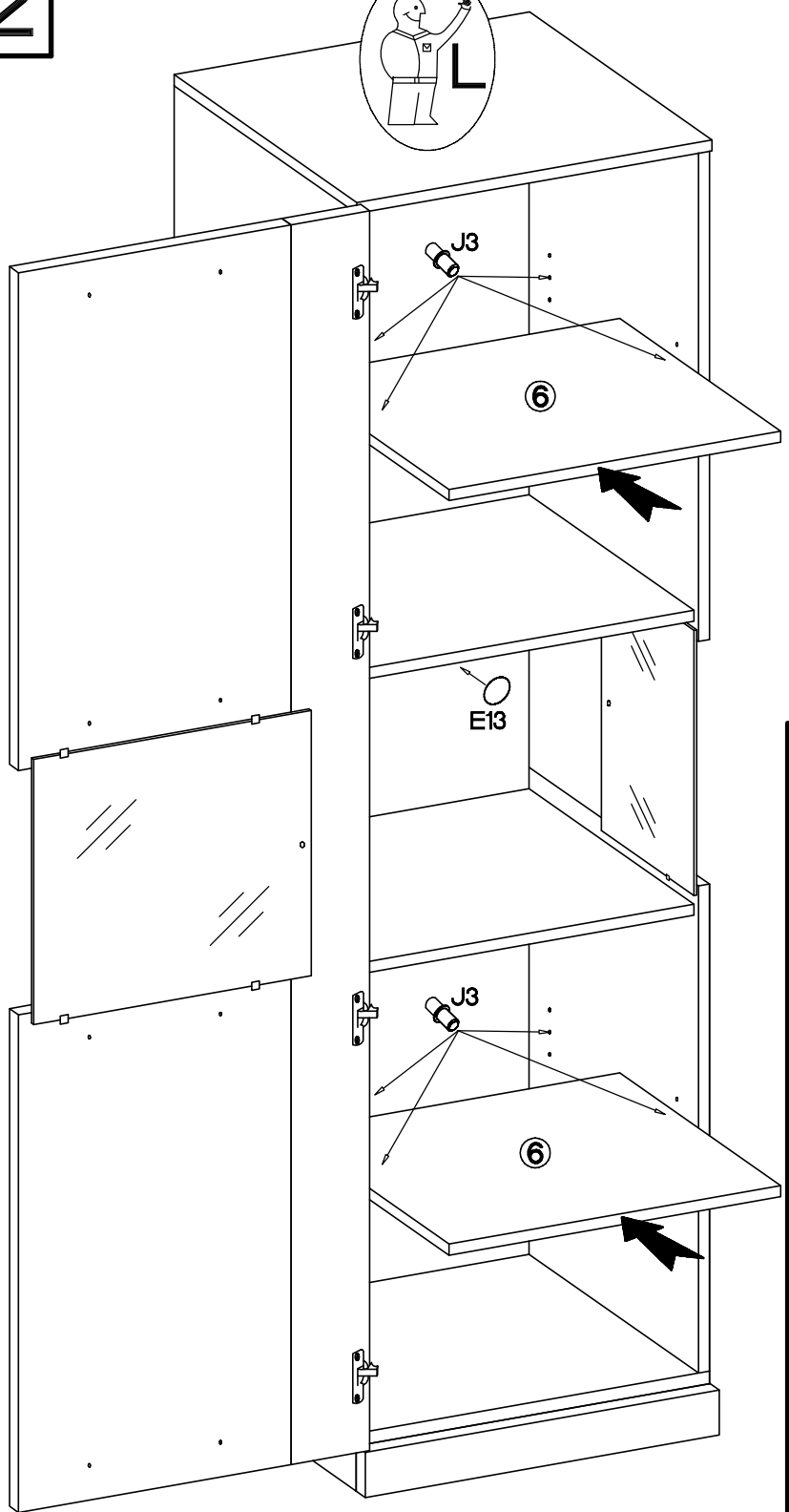

ROCK

1826-481-34
1826-481-51

481

D Unser Direktservice für Beschlaegeile
Sollte Ihnen ein Beschlaegeil fehlen, können Sie diese Servicekarte direkt an die untenstehende Adresse mailen. Wir können allerdings nur Beschlaegeile auf diesem Wege verschicken. Sollten Sie eine andere Beanstandung an Ihrem Möbelstück haben, so wenden Sie sich bitte direkt an Ihr Möbelhaus.



GB Our direct order service for fitting
If a fitting part is missing, you can e-mail this service card directly to the address below. However, we can only send fitting parts in this way. If you have any other cause for complaint concerning your item of furniture, please contact your furniture store directly.

CZ Naše přímé služby pro kování
Chybí li vám nějaký díl z kování, můžete tuto servisní kartu odcolat e mailom přímo na níže uvedenou adresu. Touto cestou však můžeme zoslat jen díly kování. Pokud byste reklamovali jiný díl nábytku, obraťte se přímo na svého prodejce nábytku.

F Bien étudier la notice de montage
S'il vous manque une ferrure, veuillez envoyer directement la présente carte service à l'adresse e-mail indiquée ci-dessous. Cependant, ceci nous permet uniquement d'envoyer des ferrures. Pour tout autre type de réclamation concernant votre meuble, veuillez contacter directement votre magasin d'ameublement.

I Il nostro servizio diretto per l'ordine della ferramenta
Qualora Vi dovesse mancare un pezzo di fissaggio, allora Vi preghiamo di inviare questa carta di servizio immediatamente all'indirizzo sottostante. Possiamo inviare i pezzi di fissaggio solamente per mezzo di questo procedimento. Qualora doveste avere qualche altra reclamazione in merito al mobile, allora Vi preghiamo di rivolgerVi direttamente al Vostro Negozio di mobili.

BG Нашето пряко обслужване за обкова
Ако липсват части от комплекта, попълнете настоящата сервисна карта и ни е-mailвайте на е-mail адреса, посочен по-долу. По този начин можем да доставим само липсващи елементи от обкова. Ако установите други дефекти по мебелите, Ви съветваме да се обърнете към мебелната къща/магазин, от който сте закупили стоката.

NL Onze directservice voor losse onderdelen
Wanneer er een onderdeel ontbreekt, kunt u deze servicekaart direct aan onderstaand e-mailadres sturen. Wij kunnen langs deze weg echter alleen beslagdelen versturen. Mocht u een ander probleem aan uw meubel hebben, verzoeken wij u contact op te nemen met uw meubeldealer.

PL Nasz bezpośredni serwis części montażowych
Jeżeli brakuje części koniecznych do montażu, prosimy o przesłanie nam niniejszej karty serwisowej na niżej podany adres e-mailowy. W ten sposób możemy przesłać Państwu tylko brakujące części. W przypadku innych reklamacji dotyczących mebla, prosimy zgłosić się do salonu meblowego, w którym został dokonany zakup.

HR Servis za okove
U slučaju da nedostaje neki od dijelova molimo vas da na dolje navedenu mail adresu pošaljete ovaj servisni obrazac. Na ovaj način mogu se dostaviti samo okovi. U slučaju da imate dodatne prigovore vezane uz komad namještaja molimo vas da se obratite izravno trgovini namještaja odjije je isti kupljen.

HU Direktszoigálatunk vasalatok esetén
Ha hiányzik egy vasalat, ezt a kártyát közvetlenül elküldheti az alább található címre. Azonban csak a vasalásokat tudunk így küldeni. Amennyiben másfajta reklamáció áll fenn bútordarabjait illetően, forduljon közvetlenül a bolti/házhoz.

SK Naš priamy servis pre časti kovania
Ak by Vám chýbala nejaká časť kovania, môžete poslať túto servisnú kartu poštou e-mailom na nižšie uvedenú adresu. Diely kovania vieme poslať iba týmto spôsobom. Ak by ste mali inú reklamáciu ohľadom Vášho nábytku, obraťte sa priamo na Vašu predajňu nábytku.

SLO Naše direktne uslužne storitve za okovje
Če vam manjka kakšno okovje, lahko to servisno kartico pošljete po e-pošti direktno na spodnji naslov. Po tej poti vam lahko pošljemo samo okovje. Če želite reklamirati kakšen drug del pohištva, se obrnite neposredno na vašo trgovino pohištva.

RO Service-ul nostru direct pentru feronerie
In cazul in care va lipseste o piesa de feronerie puteti sa trimiteți direct acest card de service prin e-mail la adresa de mai jos. Noi nu putem expedia piese de feronerie decât pe această cale. Dacă aveți o altă reclamație referitoare la piesa de mobilier, atunci vă rugăm să vă adresați direct la magazinul dvs. de mobilă.

RUS Наш прямой сервис для поставки фурнитуры
Если окажется, что Вам не хватает того или иного элемента фурнитуры, Вы можете отправить сервисную карту по факсу непосредственно на нижеуказанный адрес электронной почты. Однако, таким образом мы можем переслать лишь фурнитуру. Если же у Вас возникнут иные претензии относительно приобретенной мебели, пожалуйста, обращайтесь непосредственно в организацию, существовавшую продавца.

S Vår direktservice för beslagsdelar
Om du saknar en beslagsdel kan du skicka detta servicekort direkt till e-postadressen som anges nedan. Tänk på att detta är den enda möjligheten att skicka beslagsdelar till dig. Om du vill reklamera din möbel av en annan anledning måste du kontakta ditt möbelhus direkt.

ES Nuestro servicio directo para accesorios
Si le falta algún accesorio, puede enviar esta tarjeta de servicio directamente a la siguiente dirección. No obstante, por este método solo podemos enviar accesorios. Si tiene alguna otra objeción sobre su mueble, consulte directamente con su mueblería.

TR Donatılar için doğrudan servisimiz
Bir donatınız eksikse bu servis kartını doğrudan aşağıda bulunan adrese doğrudan mail yazabilirsiniz. Sadece bu yolla donatılar gönderilebilir. Mobilyanızda başka şikayetiniz varsa lütfen doğrudan mobilya satıcınıza danışın.

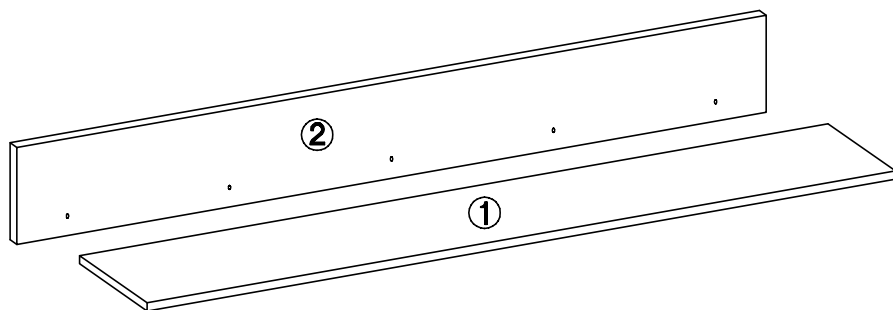

4	2	2	2	2	5	1
4	2	2	2	2	5	1
M4	O3	K7	O7	J5	B	O
4	2	2	2	2	5	1

LKZ 80106

Grund der Beanstandung / Reason of the objection:

Möbelhaus / Furniture store:

Name / Name:

Telefon / Telephone:

PLZ / postal code:

Ort / City:

Strasse / Street:

Haus-Nr. / House No.:

@E-Mail:

1

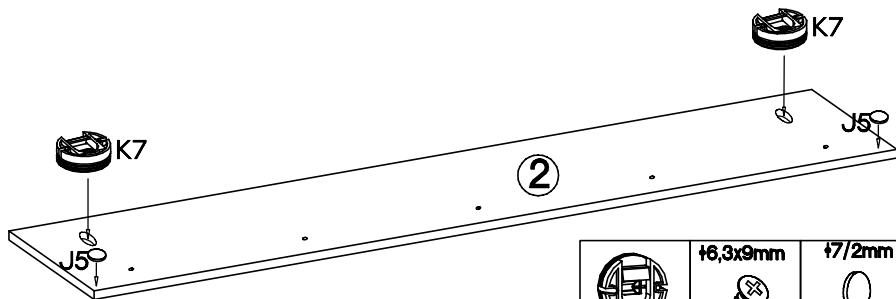
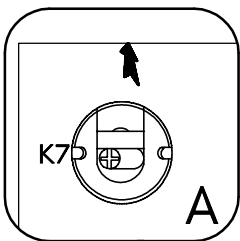
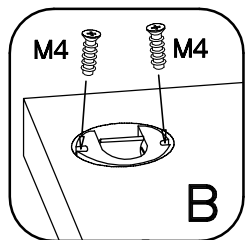

	$\pm 6,3 \times 9 \text{mm}$	$\pm 7/2 \text{mm}$
K7	M4	J5
2	4	2

2

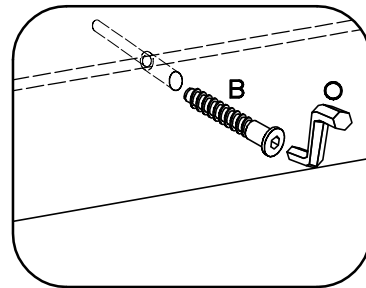
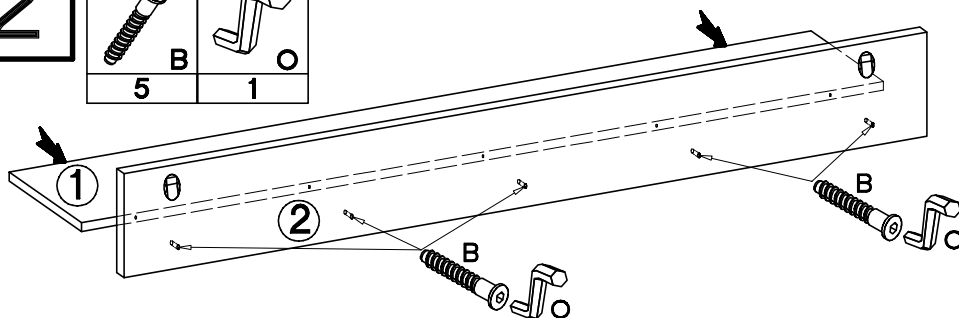
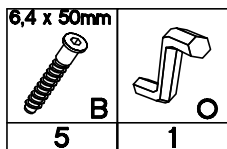

3

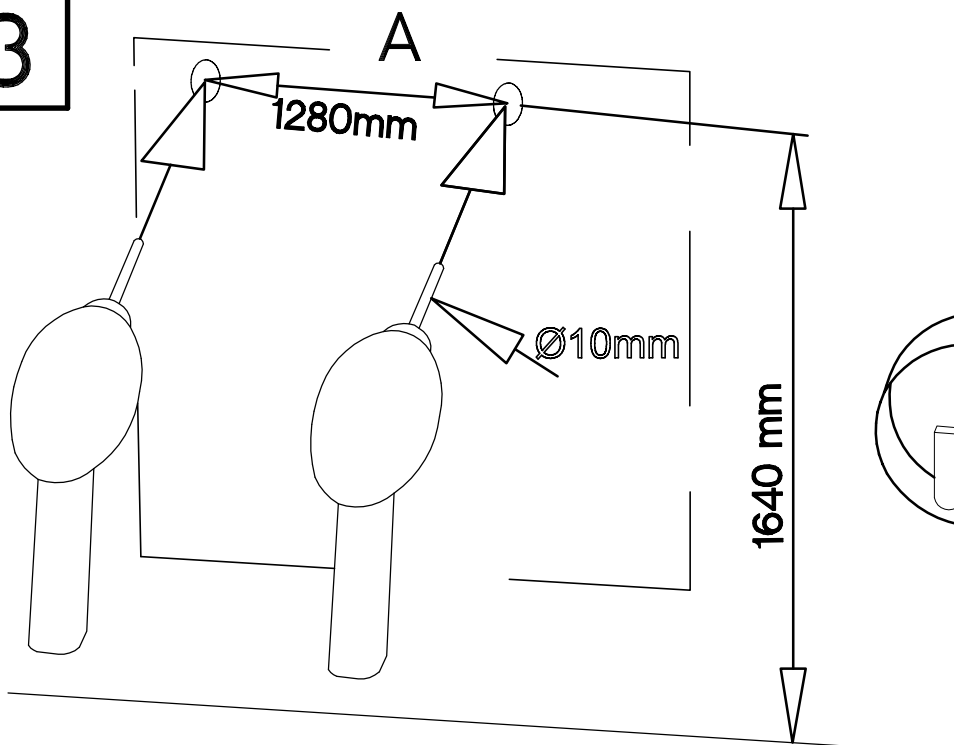

$5/45 \text{mm}$	$\pm 10 \times 50 \text{mm}$
O3	O7
2	2

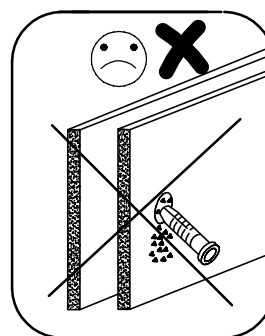
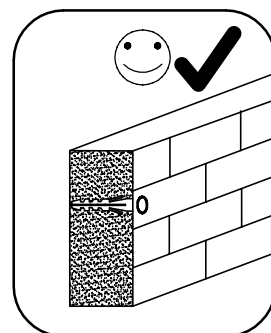
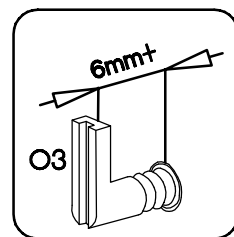
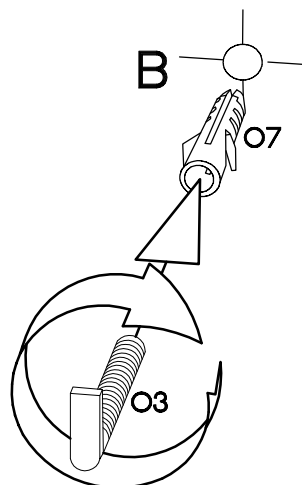

C

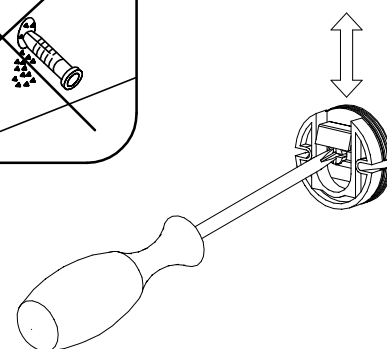
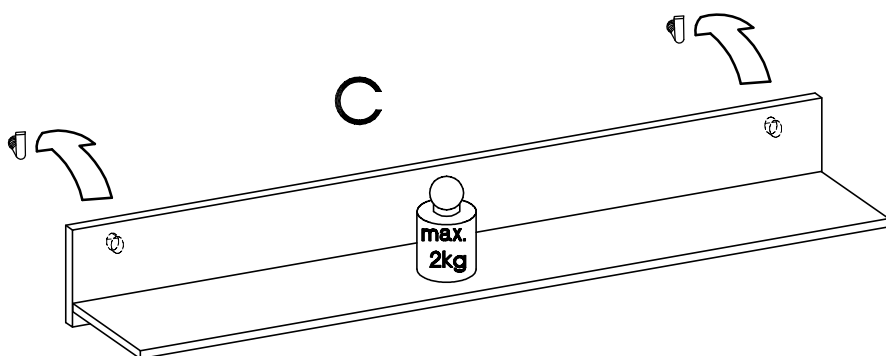

ROCK

1826-537-35
 1826-537-48
 1826-537-49

537

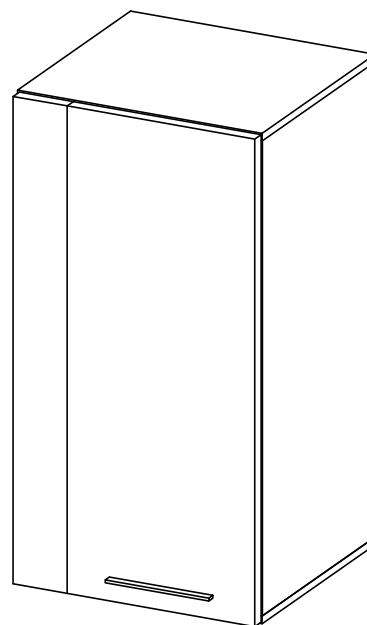
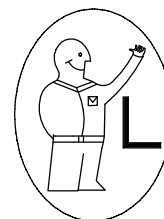
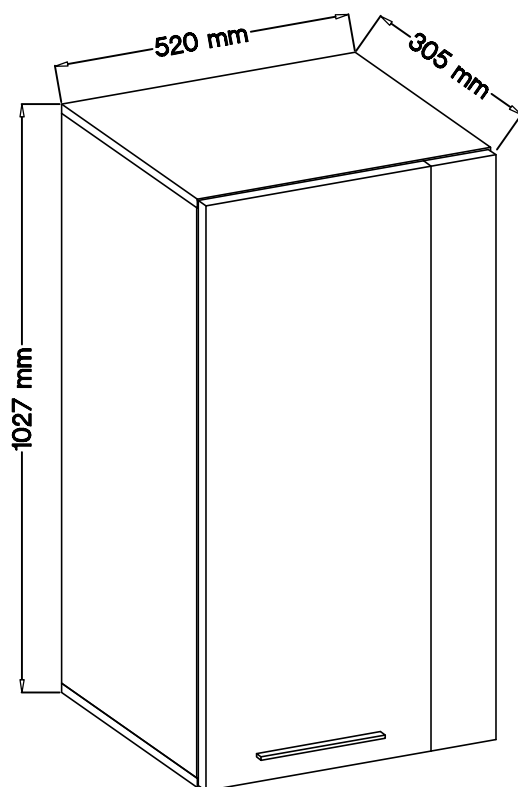
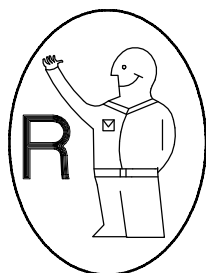
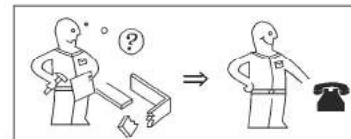
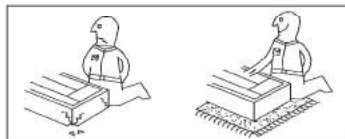
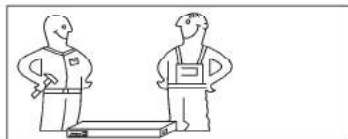

festziehen / tighten / Sareniere / serrer / stringere / utáhnout / vasttrekken / zategnuti / zbiti / zaviazat / završiti / završiti / meghúzni / pevne doťahnut / trdno pritegniti / затянуть / dra át / fjar / Sıkın



eindrücken / press in / enfoncer / wcisnąć / nabattere / zatačit / Вкарайте / Indrukken / benyomni / stlačit / vtisniti / tryck in / introducere prin apă sare / вдавить / empujar / İçeri bastırın



aasmessen / measure / mesurer / misurare / opmeten / izmeriti / miara / kiméni / izmeriti / măsurare / измерить / změřit / Измерете / mät upp / zmierzyc / medir / Ölçün



drücken / press / presser / stiknout / Натиснете / vtisniti / nasinac / drukken / pritisnuti / nacisnac / prištiti / mamiť / (mody)gurutiti / apă sare / tryck fast / nacisnač / presionar / Bastırın



einschlagen / hammer in / beverni / sla in / frapper au marteau / infossare / Zabit' / zarazit / Набейте / zabit' / wbić / introducere prin bătaie / забить / zatłoc / clavar / İçeri vurun



Drehen - wenden / przekręcić - odwrócić / Keren - omdraalen / Girare - Ruotare / Okrenuti - obrnuti / Retourner - renverser / Tum over - turn around / Otwóć - obróć / Sars-pirete - obykrere / Obrnite list / Intarceți - rotii / Vrid runt - vänd / прскрутіть - повернуть / otóčit - obrátit / elforgatni - megfordítani / Girar / Çevirin

ROCK

1826-537-35
 1826-537-48
 1826-537-49

537

D Unser Direktservice für Beschlaßteile
 Sollte Ihnen ein Beschlagteil fehlen, können Sie diese Servicekarte direkt an die untenstehende Adresse mailen. Wir können allerdings nur Beschlagteile auf diesem Wege verschicken. Sollten Sie eine andere Beanstandung an Ihrem Möbelstück haben, so wenden Sie sich bitte direkt an Ihr Möbelhaus.

GB Our direct order service for fitting
 If a fitting part is missing, you can e-mail this service card directly to the address below. However, we can only send fitting parts in this way. If you have any other cause for complaint concerning your item of furniture, please contact your furniture store directly.

CZ Naše přímé služby pro kování
 Chybí li vám nějaký díl z kování, můžete tuto servisní kartu odcloak e mailom přímo na níže uvedenou adresu. Touto cestou však můžeme zoreslat jen díly kování. Pokud byste reklamovali jiný díl nábytku, obraťte se přímo na svého prodejce nábytku.

F Bien étudier la notice de montage
 S'il vous manque une ferrure, veuillez envoyer directement la présente carte service à l'adresse e-mail indiquée ci-dessous. Cependant, ceci nous permet uniquement d'envoyer des ferrures. Pour tout autre type de réclamation concernant votre meuble, veuillez contacter directement votre magasin d'ameublement.

I Il nostro servizio diretto per l'ordine della ferramenta
 Qualora Vi dovesse mancare un pezzo di fissaggio, allora Vi preghiamo di inviare questa carta di servizio immediatamente all'indirizzo sottostante. Possiamo inviare i pezzi di fissaggio solamente per mezzo di questo procedimento. Qualora doveste avere qualche altra reclamazione in merito al mobile, allora Vi preghiamo di rivolgerVi direttamente al Vostro Negozio di mobili.

BG Целевата електронна услуга за обков
 Ако липсват части от комплекта, попълнете настоящата сервисна карта и я изпратете на e-mail адреса, посочен по-долу. По този начин можем да доставим само липсващи елементи от обкова. Ако установите други дефекти по мебелите, Ви съветваме да се обърнете към мебелната къща/магазин, от който сте закупили стоката.

NL Onze directservice voor losse onderdelen
 Wanneer er een onderdeel ontbreekt, kunt u deze servicekaart direct aan onze e-mailadres sturen. Wij kunnen langs deze weg echter alleen beslagdelen versturen. Mocht u een ander probleem aan uw meubel hebben, verzoeken wij u contact op te nemen met uw meubeldealer.

PL Nasz bezpośredni serwis części montażowych
 Jeżeli brakuje części koniecznych do montażu, prosimy o przesłanie nam niniejszej karty serwisowej na niżej podany adres e-mailowy. W ten sposób możemy przesyłać Państwu tylko brakujące części. W przypadku innych reklamacji dotyczących mebla, prosimy zgłosić się do salonu meblowego, w którym został dokonany zakup.

HR Servis za okove
 U slučaju da nedostaje neki od dijelova molimo vas da na dolje navedenu mail adresu pošaljete ovaj servisni obrazac. Na ovoj način mogu se dostaviti samo okovi. U slučaju da imate dodatne prigovore vezane uz komad namještaja molimo vas da se obratite izravno trgovini namještaja odjije je isti kupljen.

HU Direktzorgálatunk vasalatok esetén
 Ha hiányzik egy vasalatt, ezt a kártyát közvetlenül elküldheti az alább található címre. Azonban csak vasalattokat tudunk így küldeni. Amennyiben másfajta reklamációt áll fenn bütördarabját illetően, forduljon közvetlenül a bütördarabhoz.

SK Naš priamy servis pre časti kovania
 Ak by Vám chýbala nejaká časť kovania, môžete poslať túto servisnú kartu poslať e-mailom na nižšie uvedenú adresu. Dieľky kovania vieme poslať iba týmto spôsobom. Ak by ste mali inú reklamáciu ohľadom Vášho nábytku, obráťte sa priamo na Vašu predajňu nábytku.

SLO Naše direktne uslužne storitve za okovje
 Če vam manjka kakšno okovje, lahko to servisno kartico pošljete po e-pošti direktno na spodnji naslov. Po tej poti vam lahko pošljemo samo okovje. Če želite reklamirati kakšen drug del pohištva, se obrnite neposredno na vašo trgovino pohištva.

RO Service-ul nostru direct pentru feronerie
 In cazul in care va lipseste o piesa de feronerie puteti sa trimiteti direct acest card de service prin e-mail la adresa de mai jos. Noi nu putem expedia piese de feronerie decit pe acestaa cale. Dacã aveți o altã reclamãtie referitoare la piesa de mobilier, atunci vã rugãm sã vã adresatã direct la magazinul dvs. de mobila.

RUS Наш прямой сервис для поставок фурнитуры
 Если окажется, что Вам не хватает того или иного элемента фурнитуры, Вы можете отправить сервисную карту по факсу непосредственно на нижеуказанный адрес электронной почты. Однако, таким образом мы можем переслать лишь фурнитуру. Если же у Вас возникнут иные претензии относительно приобретенной мебели, пожалуйста, обращайтесь непосредственно в организацию, существовавшую продавца.



S Vår direktservice för beslagsdelar
 Om du saknar en beslagsdel kan du skicka detta servicekort direkt till e-postadressen som anges nedan. Tänk på att detta är den enda möjligheten att skicka beslagsdelar till dig. Om du vill reklamera din möbel av en annan anledning måste du kontakta ditt möbelhus direkt.





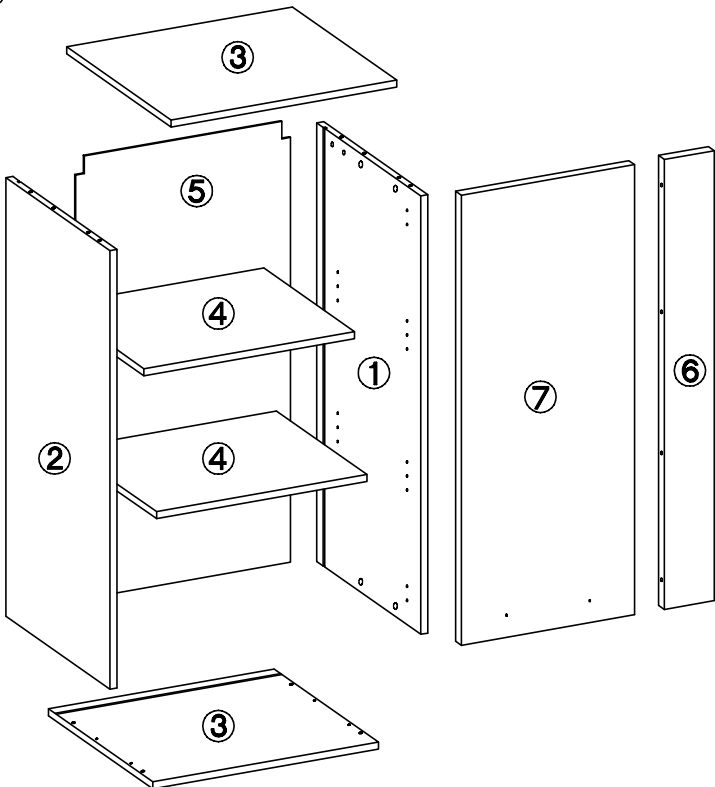



ES Nuestro servicio directo para accesorios
 Si le falta algún accesorio, puede enviar esta tarjeta de servicio directamente a la siguiente dirección. No obstante, por este método solo podemos enviar accesorios. Si tiene alguna otra objeción sobre su mueble, consulte directamente con su mueblería.

TR Donatılar için doğrudan servisimiz
 Bir donatınız eksikse bu servis kartını doğrudan aşağıda bulunan adrese doğrudan mail yazabilirsiniz. Sadece bu yolla donatılar gönderilebilir. Mobilyanızda başka şikayetiniz varsa lütfen doğrudan mobilya satıcınıza danışın.

⑦, ⑧ =  max. 5kg



		
#5.0x60mm	#10x50mm	
P12	O7	K16
4	4	2

							
O1	K26	K25	P8	A2	G	P5	H
1	1	1	4	4	2	4	2
L-20mm	#15/12mm	#8x30mm				L-192mm	#4.0x27mm
D2	C	A	E	L	J3	S17	R1
8	8	8	8	6	8	1	2

 1B:

LKZ 80106

Grund der Beanstandung / Reason of the objection: _____

Möbelhaus / Furniture store: _____



Name / Name: _____ Telefon / Telephone: _____

PLZ / postal code: _____ Ort / City: _____

Strasse / Street: _____

Haus-Nr. / House No.: _____ @E-Mail: _____

1

	
O1	A2
1	4

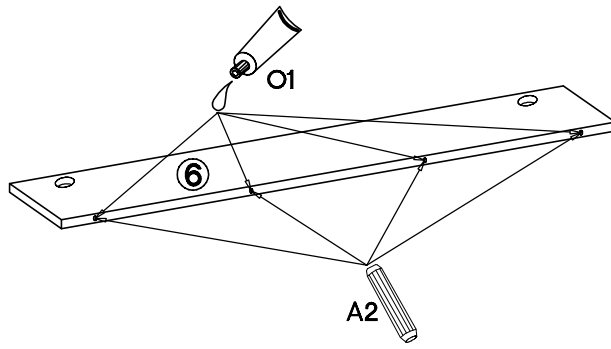

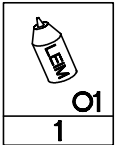
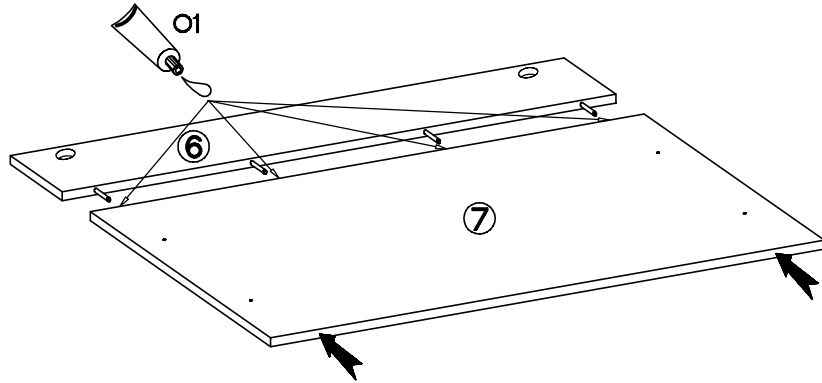
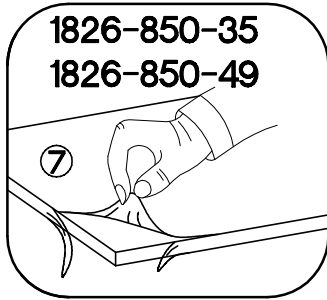

2

1826-850-35
1826-850-49







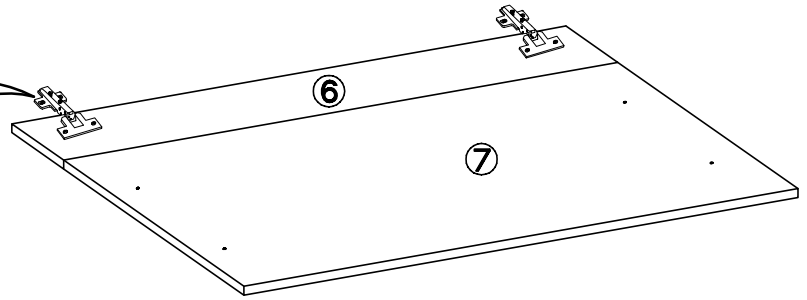
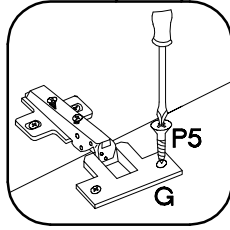
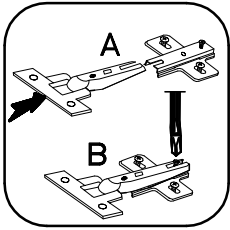

3

		
G	P5	H
2	4	2



4

					
D2	C	A	K26	K25	P8
8	8	8	1	1	4

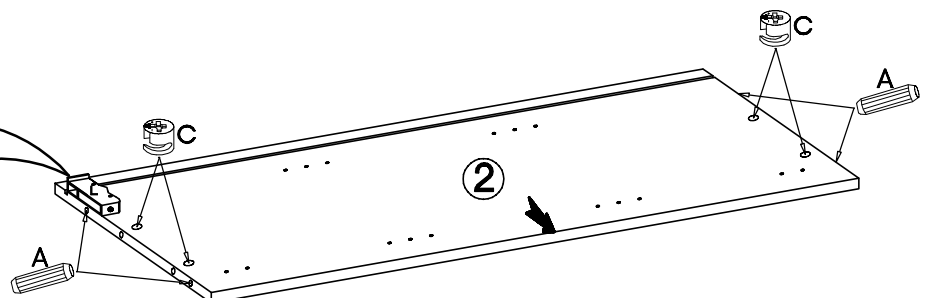
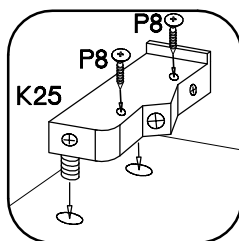
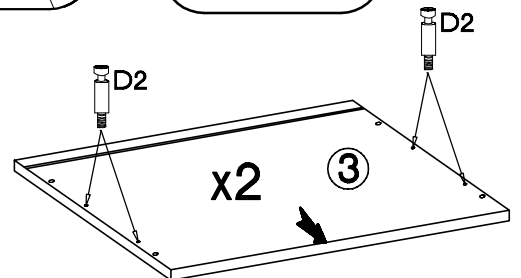
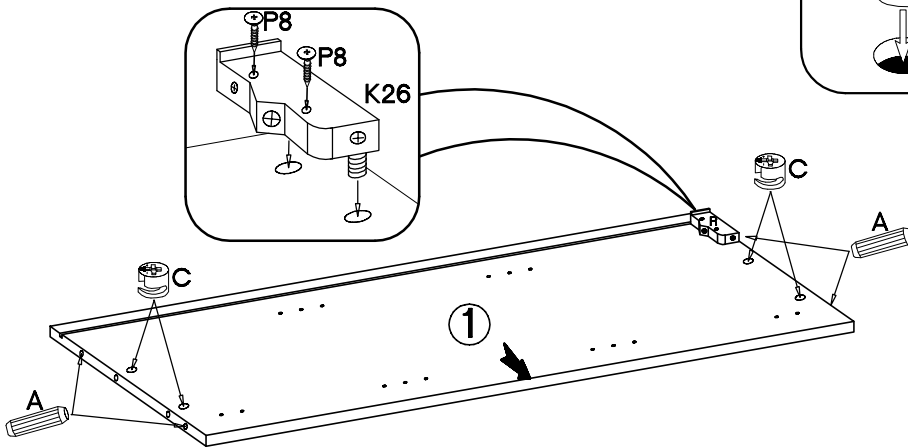
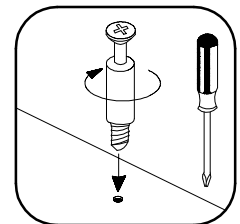
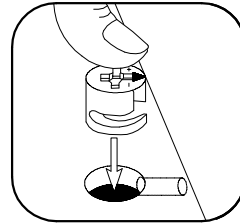

5

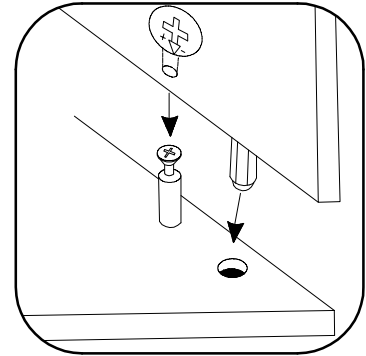
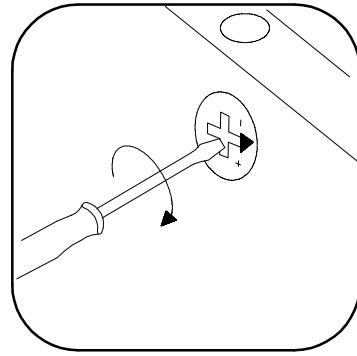
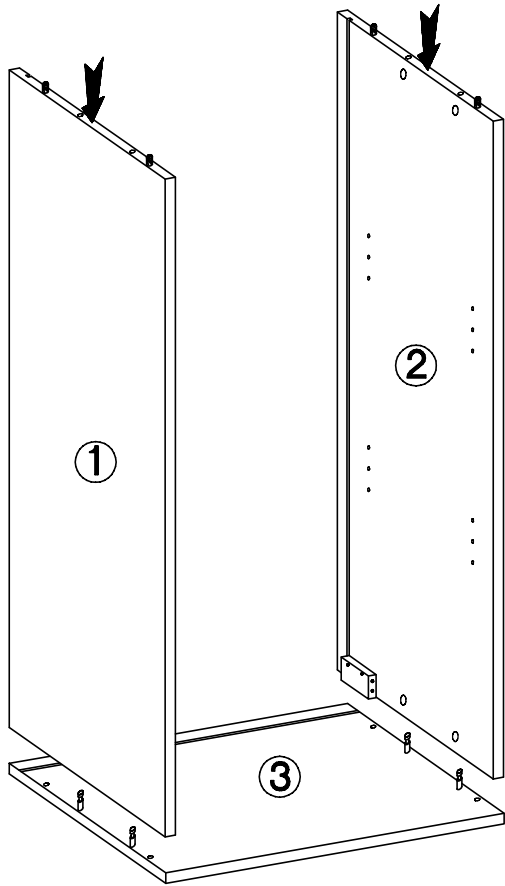

6

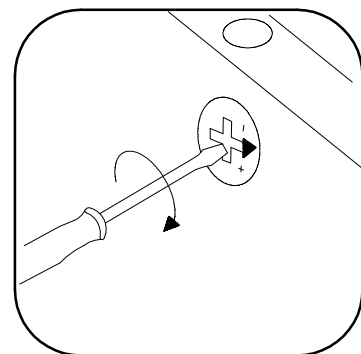
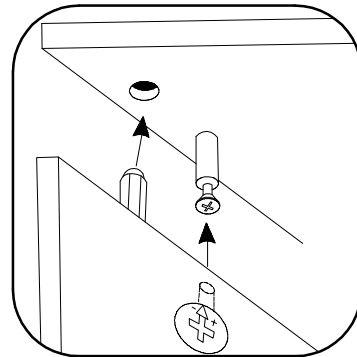
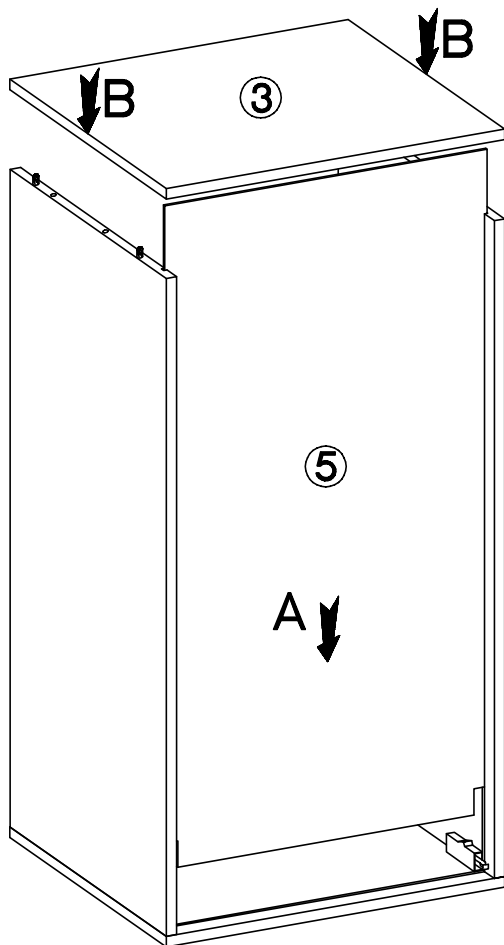

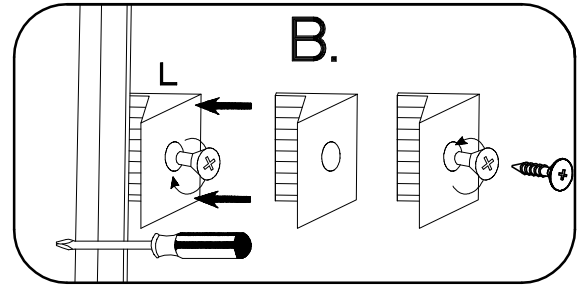
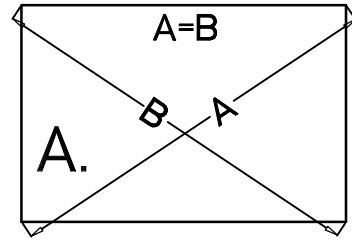
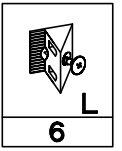
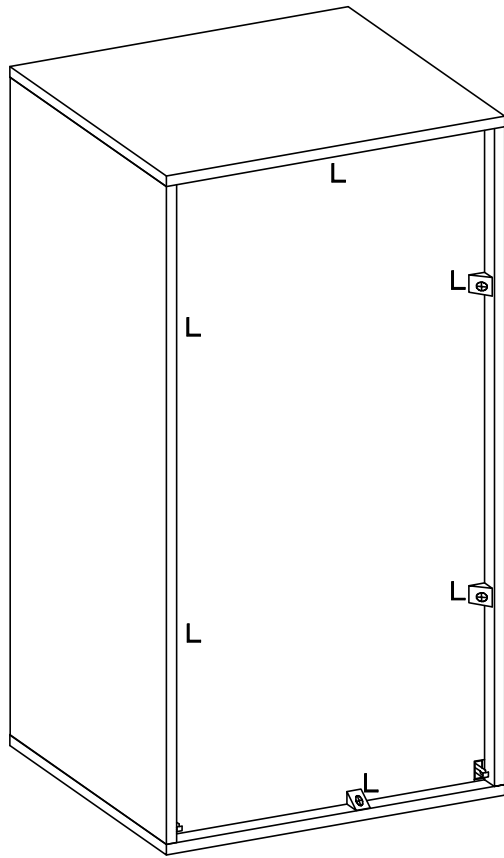

7

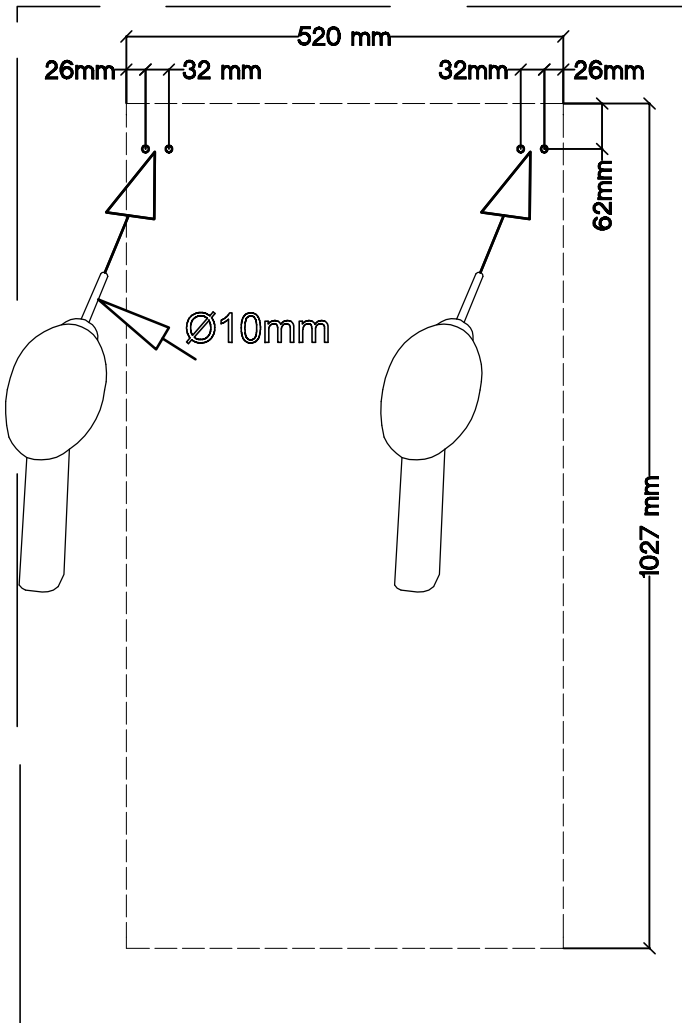

8



		
P12	O7	K16
4	4	2

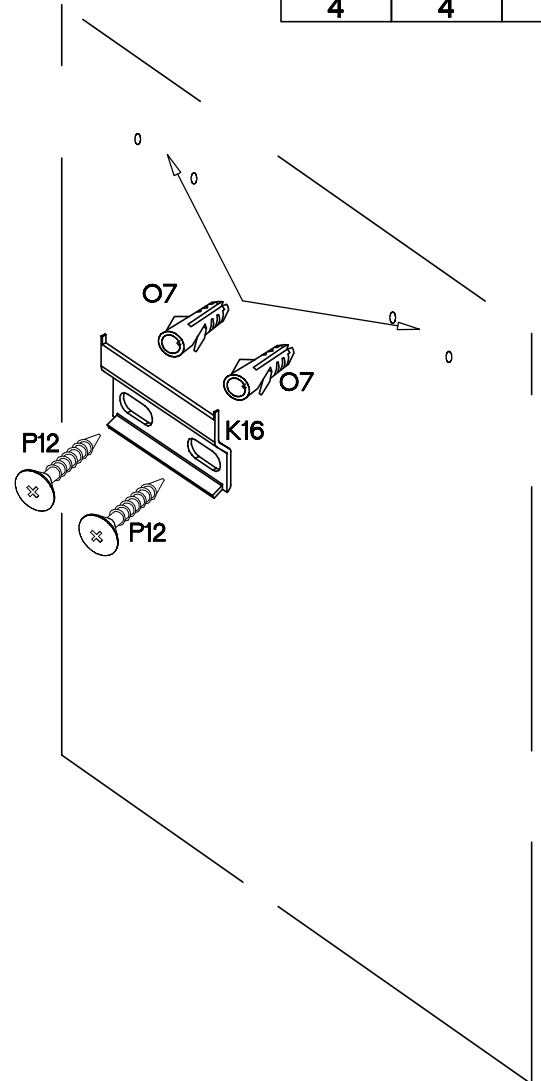

9

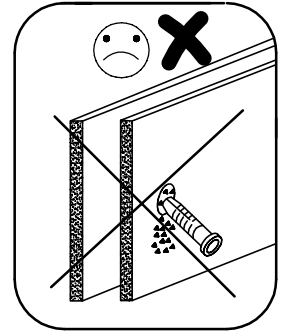
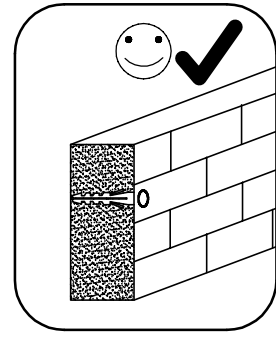
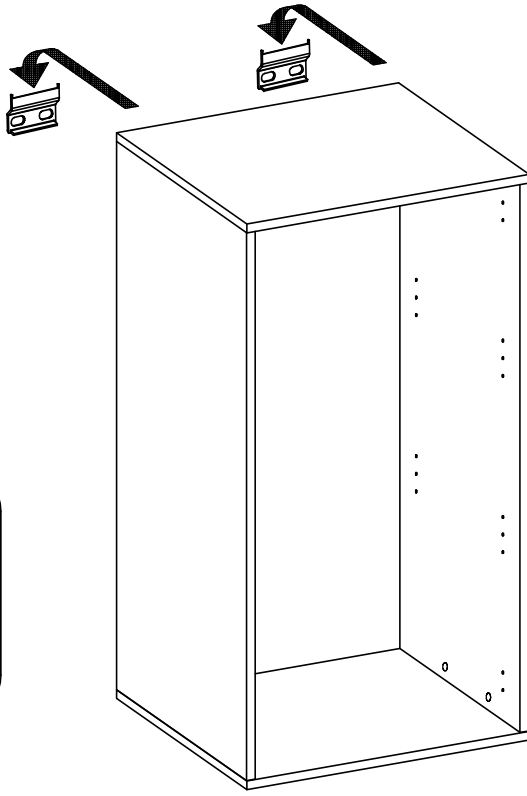
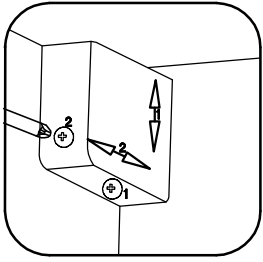
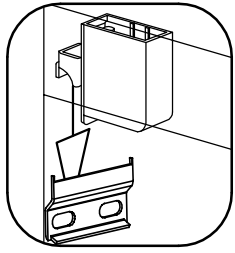

10

E	J3	L=192mm S17	4.0x27mm R1
8	8	1	2

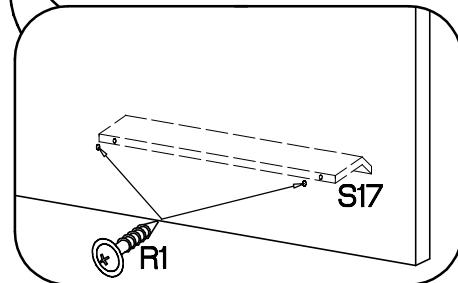
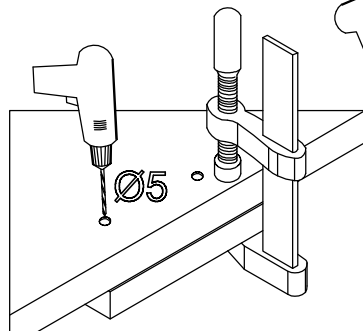
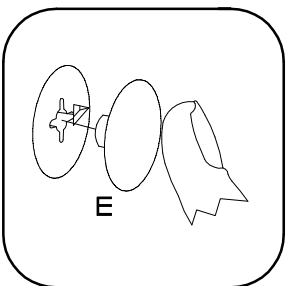
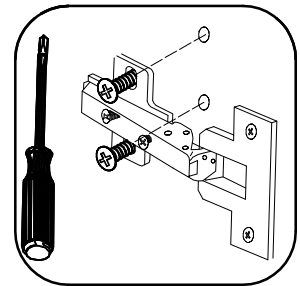
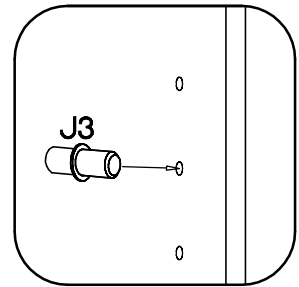
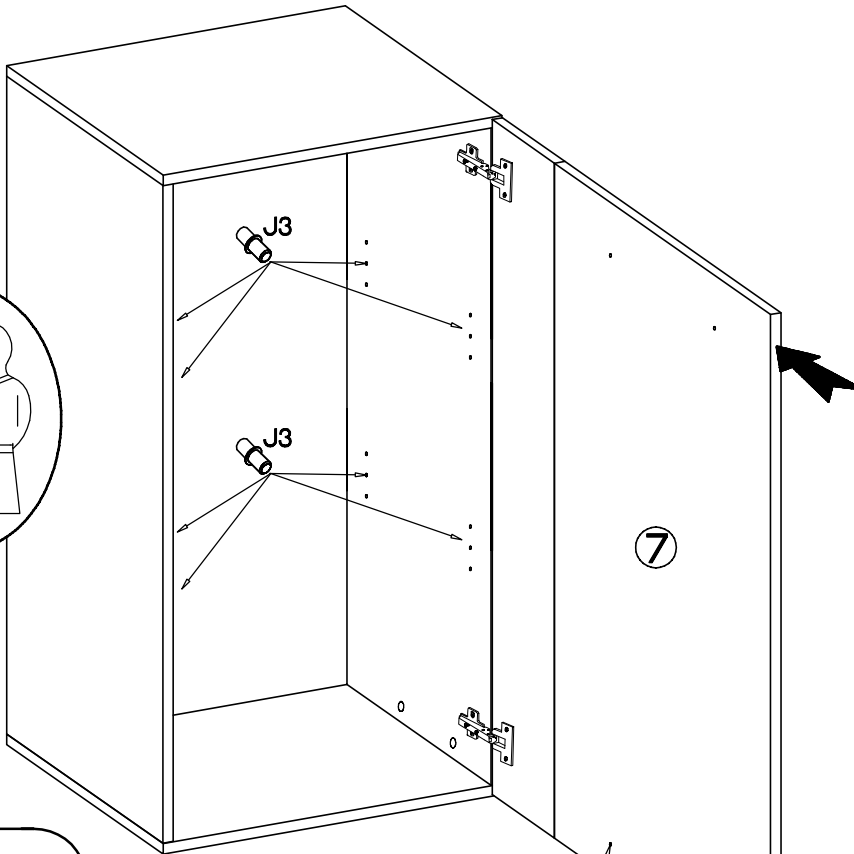
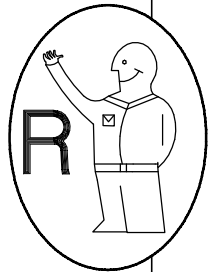

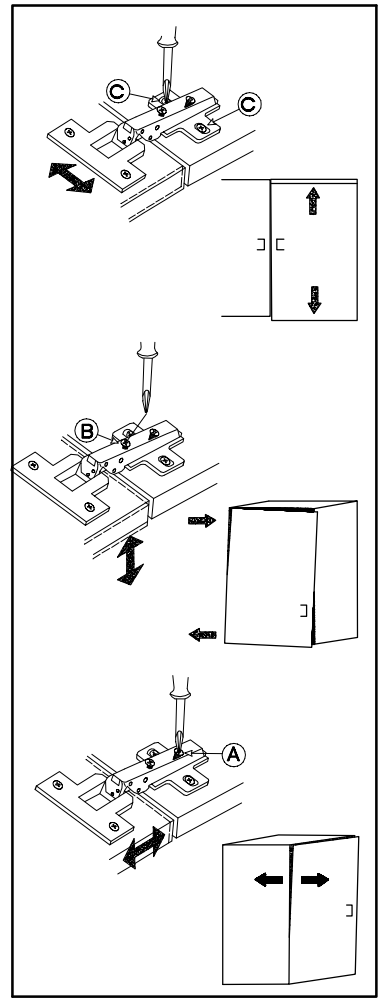
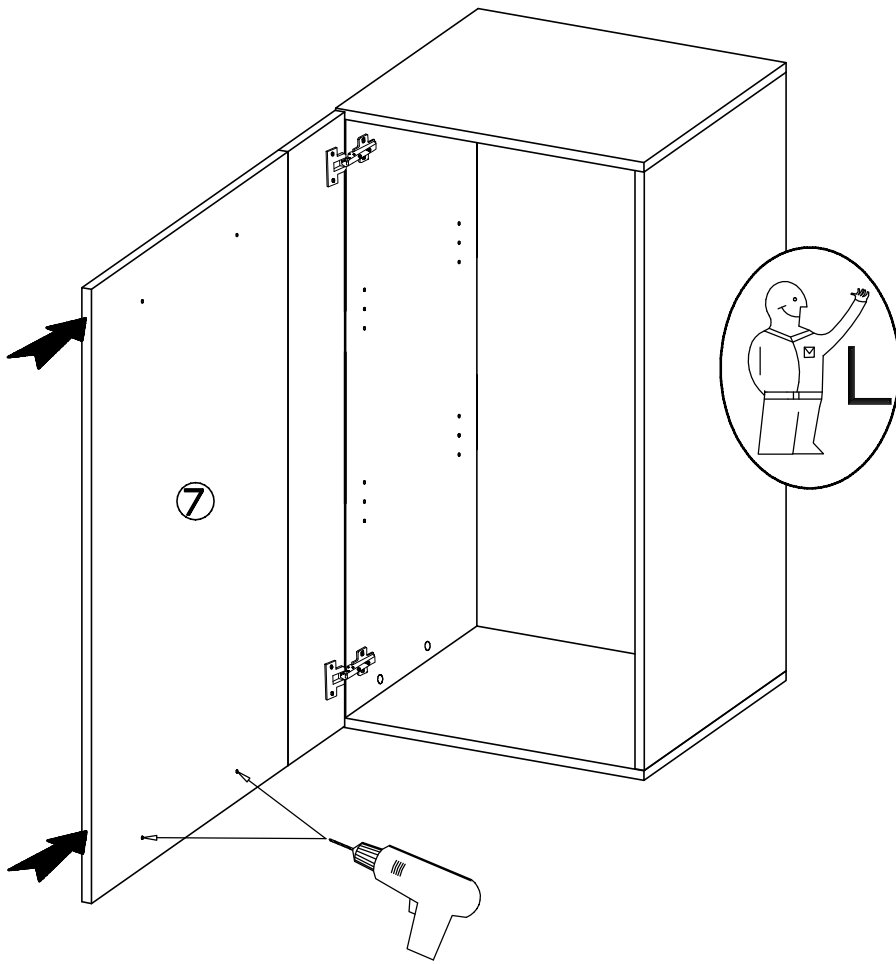

11

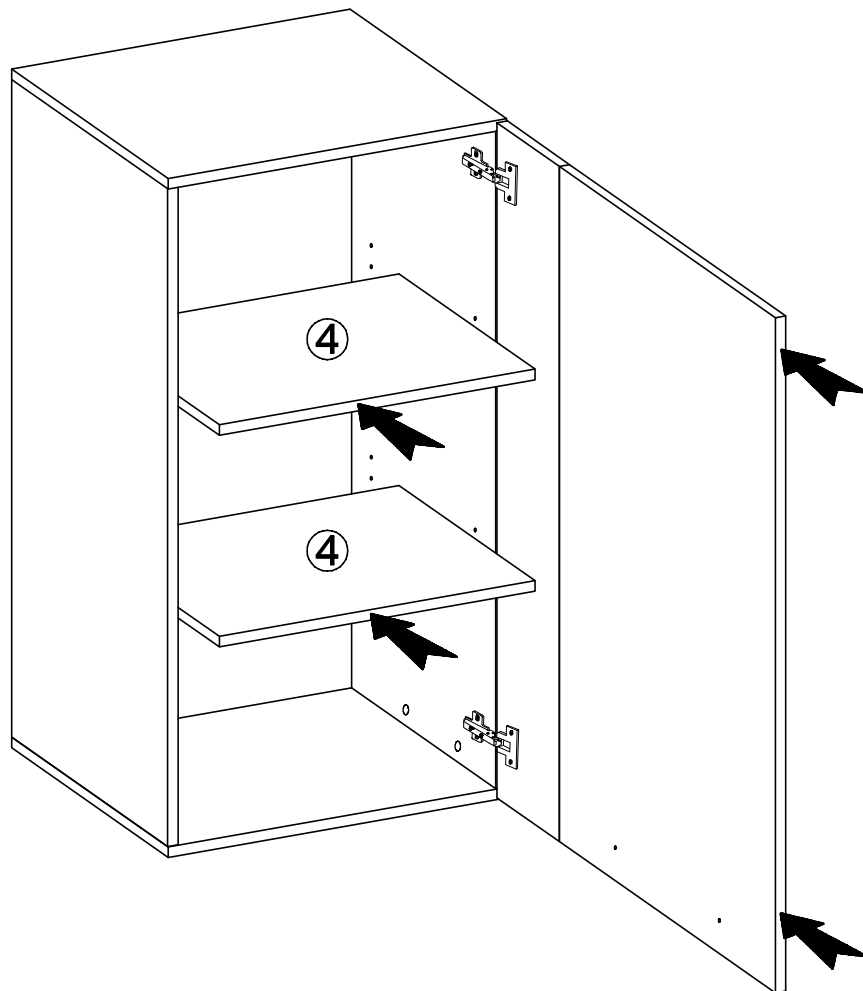

ROCK

1826-852-35
 1826-852-48
 1826-852-49

852

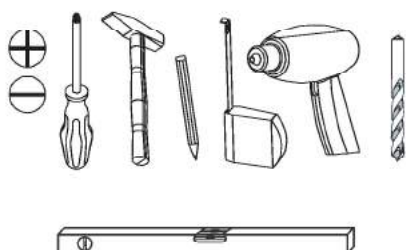
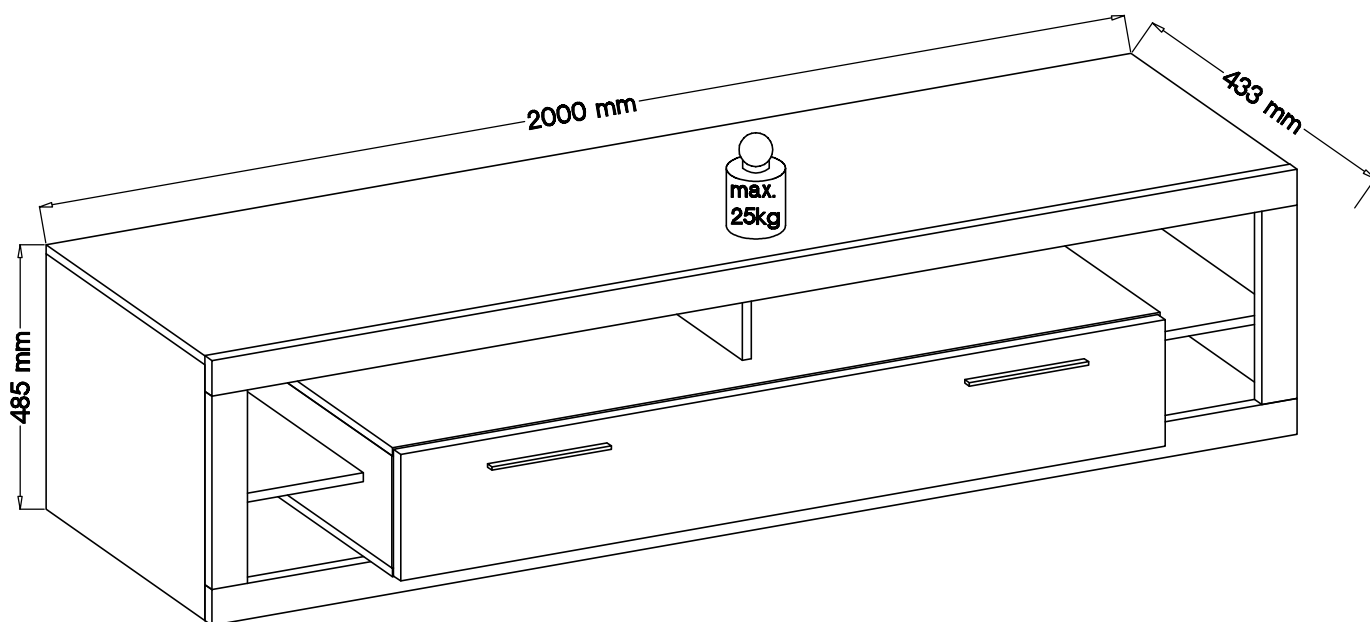
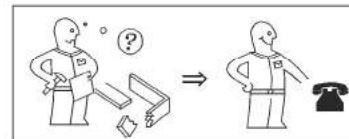
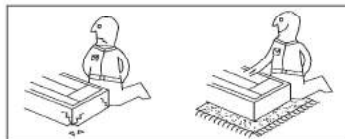
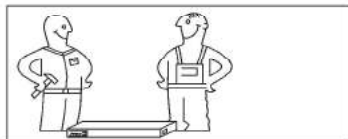

festziehen / tighten / Sareniere / serrer / stringere / utáhnout / vasttrekken / zategnuti / збігнути / свіжати / завлісати / змусити / meghúzni / pevne dotáhnut / trdno pritegniti / затянуть / dra át / fjar / Sıkın



eindrücken / press in / enfoncer / wcisnąć / nabatere / zatačit / Вкарайте / Indrukken / benyomni / stlačit / vtisniti / tryck in / introducere prin apă sare / вдавить / empujar / İçeri bastırın



aasmessen / measure / mesurer / măsurare / opmeten / izmeriti / miera / kimémi / izmeriti / măsurare / измерить / změřit / Измерете / mät upp / zmierzyc / medir / Ölçün



drücken / press / presser / stiknout / Напичнете / vtisniti / nasinac / drukken / pritisnuti / nacsinac / prištniti / мамати / (по)сгунати / apă sare / tryck fast / nacsinac / presionar / Bastırın



einschlagen / hammer in / beverni / sla in / frapper au marteau / infossare / Zabit / zarazit / Набийте / zabit / wbici / introducere prin bătaie / забить / zatnout / clavar / İçeri vurun



Drehen - wenden / przekręcić - odwrócić / Keren - omdraalen / Girare - Ruotare / Okrenuti - obrnuti / Rebuimer - renverser / Tum over - turn around / Oțoche - obratite / Sars-pirete - обьърете / Obrnite list / Introarceți - rotii / Vrid runt - vänd / прскрутіть - повернуть / otóčit - obrátit / elforgatni - megfordítani / Girar / Çevirin

ROCK

1826-852-35
 1826-852-48
 1826-852-49

852

D Unser Direktservice für Beschlaegeile
 Sollte Ihnen ein Beschlaegeile fehlen, können Sie diese Servicekarte direkt an die untenstehende Adresse mailen. Wir können allerdings nur Beschlaegeile auf diesem Wege verschicken. Sollten Sie eine andere Beanstandung an Ihrem Möbelstück haben, so wenden Sie sich bitte direkt an Ihr Möbelhaus.

GB Our direct order service for fitting
 If a fitting part is missing, you can e-mail this service card directly to the address below. However, we can only send fitting parts in this way. If you have any other cause for complaint concerning your item of furniture, please contact your furniture store directly.

CZ Naše přímé služby pro kování
 Chybí li vám nějaký díl z kování, můžete tuto servisní kartu odeslat e-mailem přímo na níže uvedenou adresu. Touto cestou však můžeme zoslat jen díly z kování. Pokud byste reklamovali jiný díl nábytku, obraťte se přímo na svého prodejce nábytku.

F Bien étudier la notice de montage
 S'il vous manque une ferrure, veuillez envoyer directement la présente carte service à l'adresse e-mail indiquée ci-dessous. Cependant, ceci nous permet uniquement d'envoyer des ferrures. Pour tout autre type de réclamation concernant votre meuble, veuillez contacter directement votre magasin d'ameublement.

I Il nostro servizio diretto per l'ordine della ferramenta
 Qualora Vi dovesse mancare un pezzo di fissaggio, allora Vi preghiamo di inviare questa carta di servizio immediatamente all'indirizzo sottostante. Possiamo inviare i pezzi di fissaggio solamente per mezzo di questo procedimento. Qualora dovete avere qualche altra reclamazione in merito al mobile, allora Vi preghiamo di rivolgerVi direttamente al Vostro Negozio di mobili.

BG Нашето пряко обслужване за обкове
 Ако липсват части от комплекта, попълнете настоящата сервисна карта и я изпратете на e-mail адреса, посочен по-долу. По този начин можем да доставим само липсващи елементи от обкове. Ако установите други дефекти по мебелите, въпреки че да се обърнете към мебелната къща/магазин, от който сте закупили стоката.

NL Onze directservice voor loose onderdelen
 Wanneer er een onderdeel ontbreekt, kunt u deze servicekaart direct aan onze e-mailadres sturen. Wij kunnen slechts losse onderdelen beslagdelen versturen. Mocht u een ander probleem aan uw meubel hebben, verzoeken wij u contact op te nemen met uw meubeldealer.

PL Nasz bezpośredni serwis części montażowych
 Jeżeli brakuje części koniecznych do montażu, prosimy o przesłanie nam niniejszej karty serwisowej na niżej podany adres e-mailowy. W ten sposób możemy przesłać Państwu tylko brakujące części. W przypadku innych reklamacji dotyczących mebla, prosimy zgłosić się do salonu meblowego, w którym został dokonany zakup.

HR Servis za okove
 U slučaju da nedostaje neki od dijelova molimo vas da na dolje navedenu mail adresu pošaljete ovaj servisni obrazac. Na ovaj način mogu do doći samo okovi. U slučaju da imate dodatne prigovore vezane uz komad namještaja molimo vas da se obratite izravno trgovini namještaja odjaje je isti kupljen.

HU Direktzolgáltatunk vasalatok esetén
 Ha hiányzik egy vasalat, ezt a kártyát közvetlenül elküldheti az alább található címre. Azonban csak vasalatok tudunk így küldeni. Amennyiben másfajta reklamáció áll fenn bútordarabjait illetően, forduljon közvetlenül a bolti/házhoz.

SK Naše priamy servis pre časti kovania
 Ak by Vám chýbala nejaká časť kovania, môžete poslať túto servisnú kartu priamo na nižšie uvedenú e-mailovú adresu. Diely kovania vieme poslať iba týmto spôsobom. Ak by ste mali inú reklamáciu ohľadom Vášho nábytku, obráťte sa priamo na Vašu predajňu nábytku.

SLO Naše direktne uslužne storitve za okovje
 Če vam manjka kakšno okovje, lahko to servisno kartico pošljete po e-pošti direktno na spodnji naslov. Po tej poti vam lahko pošljemo samo okovje. Če želite reklamirati kakšen drug del pohištva, se obrnite neposredno na vašo trgovino pohištva.

RO Service-ul nostru direct pentru feronerie
 In cazul in care va lipseste o piesa de feronerie puteti sa trimiteți direct acest card de service prin e-mail la adresa de mai jos. Noi nu putem expedia piese de feronerie decât pe aceasta cale. Dacă aveți o altă reclamație referitoare la piesa de mobilier, atunci vă rugăm să vă adresați direct la magazinul dvs. de mobilier.

RUS Наш прямой сервис для поставок фурнитуры
 Если окажется, что Вам не хватает того или иного элемента фурнитуры, Вы можете отправить сервисную карту по факсу непосредственно на нижеуказанный адрес электронной почты. Однако, таким образом мы можем переслать лишь фурнитуру. Если же у Вас возникнут иные претензии относительно приобретенной мебели, пожалуйста, обращайтесь непосредственно в организацию, существовавшую продавца.

S Vår direktservice för beslagsdelar
 Om du saknar en beslagsdel kan du skicka detta servicekort direkt till e-postadressen som anges nedan. Tänkt på att detta är den enda möjligheten att skicka beslagsdelar till dig. Om du vill reklamera din möbel av en annan anledning måste du kontakta ditt möbelhus direkt.

ES Nuestro servicio directo para accesorios
 Si le falta algún accesorio, puede enviar esta tarjeta de servicio directamente a la siguiente dirección. No obstante, por este método solo podemos enviar accesorios. Si tiene alguna otra objeción sobre su mueble, consulte directamente con su mueblería.

TR Donatılar için doğrudan servisimiz
 Bir donatınız eksikse bu servis kartını doğrudan aşağıda bulunan adrese doğrudan mail yazabilirsiniz. Sadece bu yolla donatılar gönderilebilir. Mobilyanızda başka şikayetleriniz varsa lütfen doğrudan mobilya satıcınıza danışın.

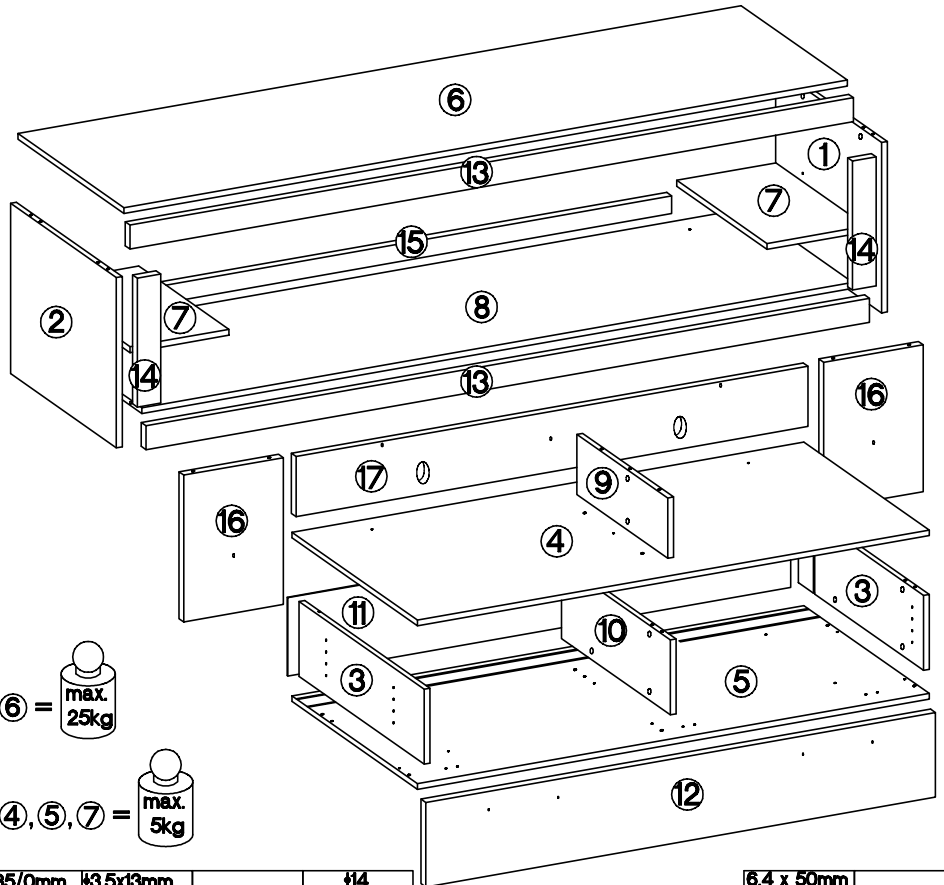

G 3	P5 12	E 6	E13 4	B 1	O 1			
H 3	S17 2	R1 4	L 8	P1 38	T9 16	P11 6	K13 2	F4 10
1B 32	D2 32	C 24	A 12	E 3	T3 2	E8 8	J3 4	R2 4

LKZ 80106

Grund der Beanstandung / Reason of the objection:

Möbelhaus / Furniture store:

Name / Name: _____ Telefon / Telephone: _____

PLZ / postal code: _____ Ort / City: _____

Strasse / Street: _____

Haus-Nr. / House No.: _____ @E-Mail: _____

1

L=20mm D2 15	#5/12mm C 12	#8x30mm A 12
--------------------	--------------------	--------------------

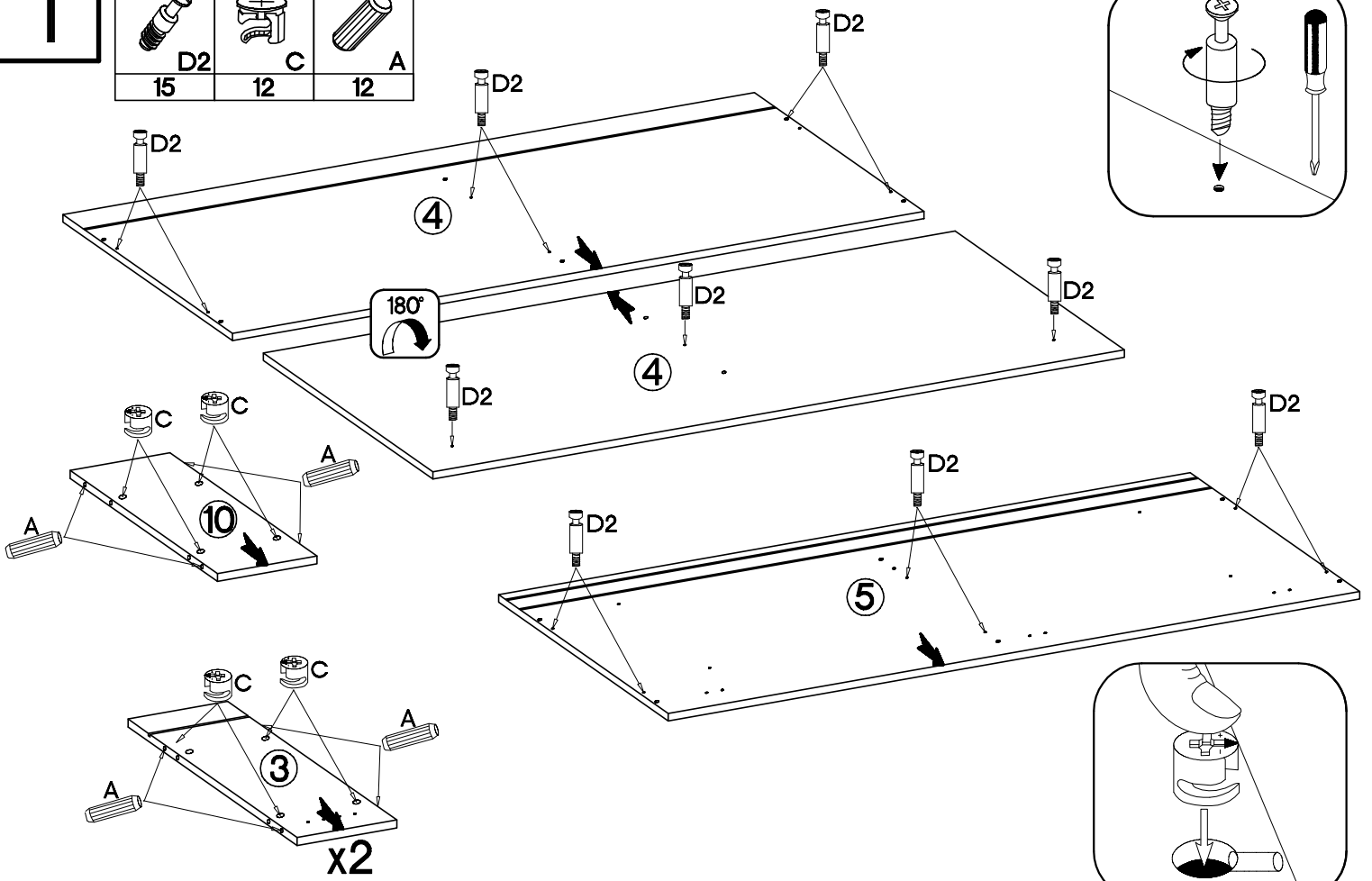
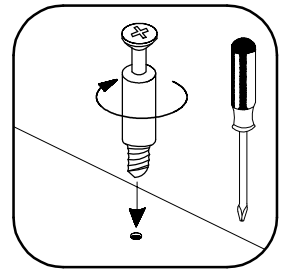

2

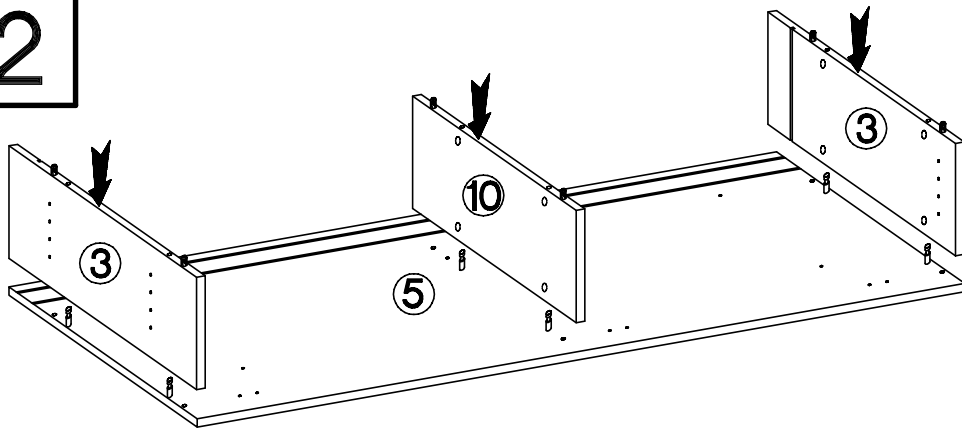

3

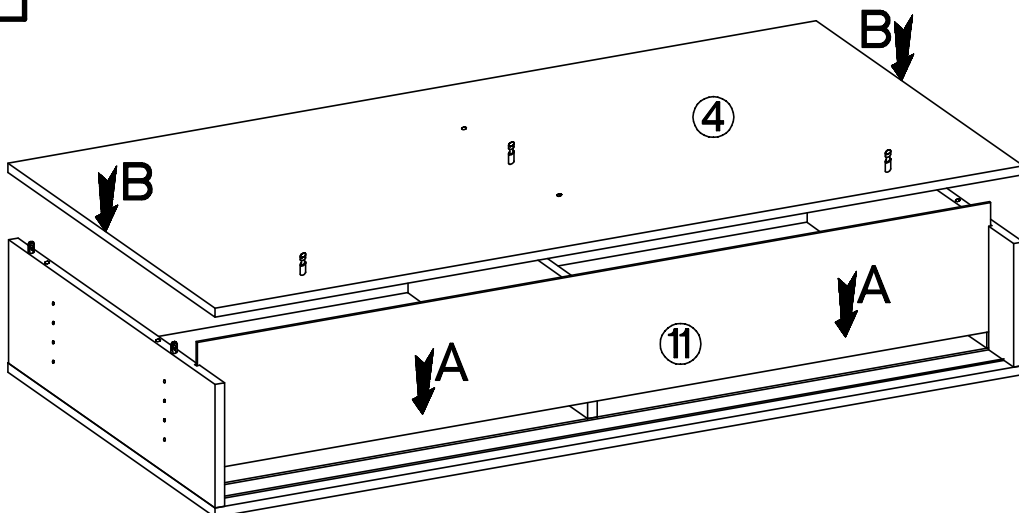

4

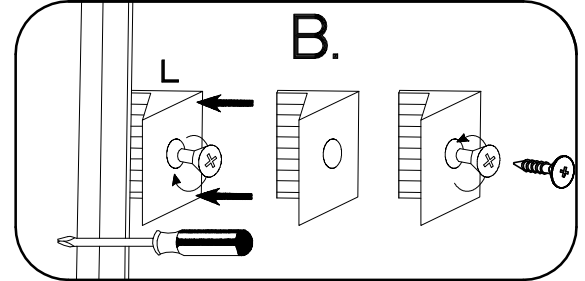
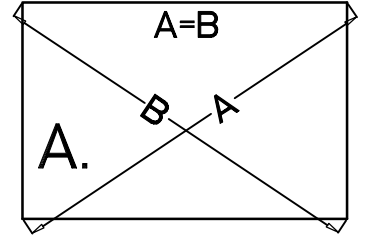
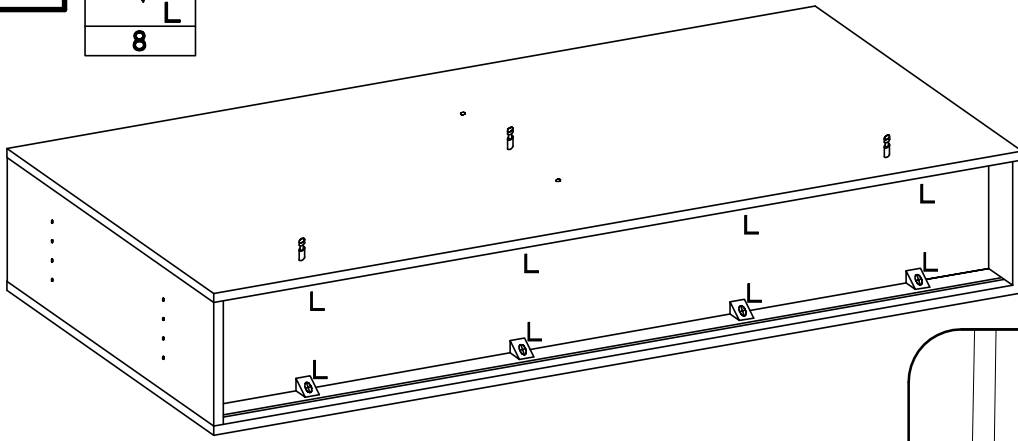
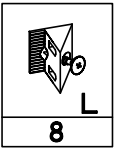

5

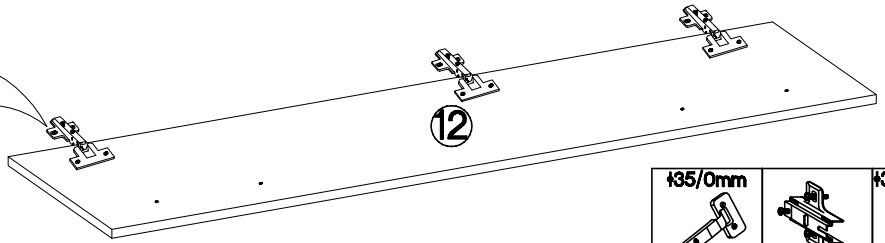
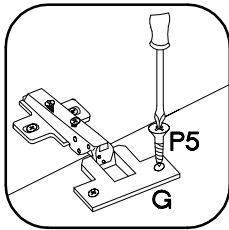
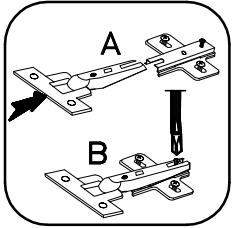







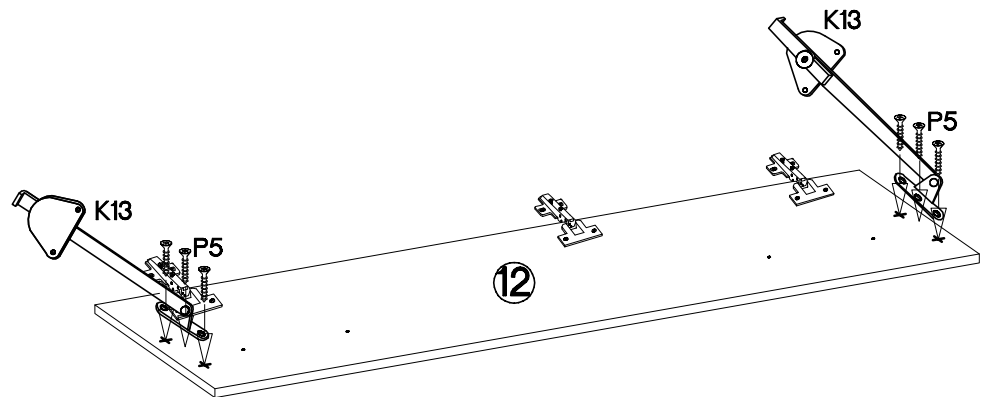
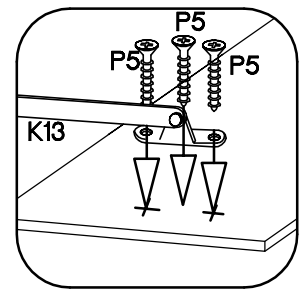
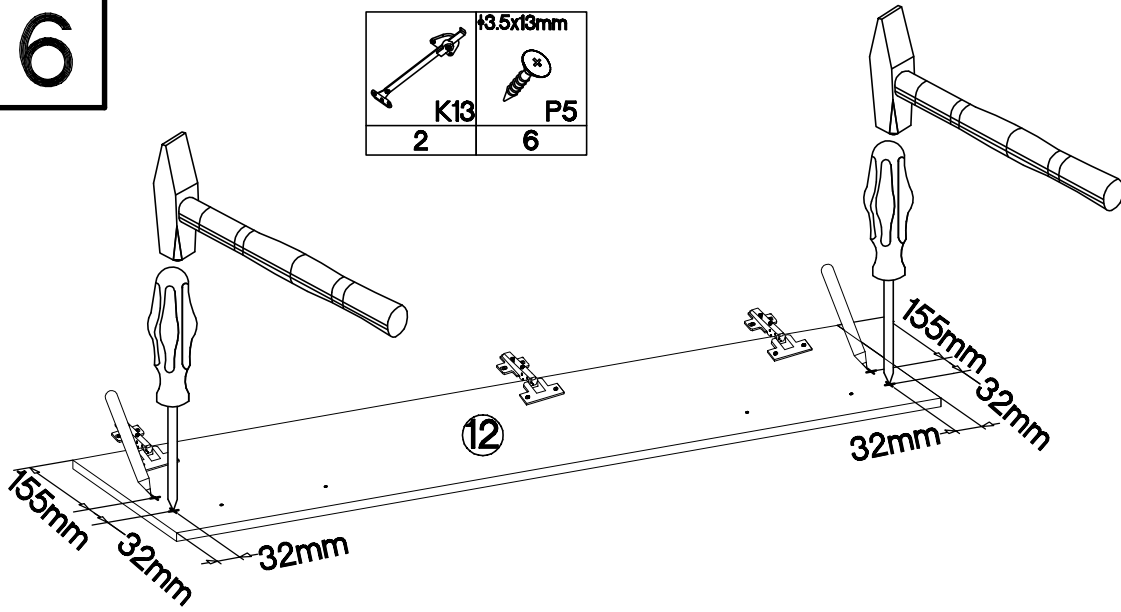

 †35/0mm G 3	 H 3	 †3.5x13mm P5 6
------------------------------	-------------------	---------------------------------

6



 K13 2	 †3.5x13mm P5 6
---------------------	---------------------------------

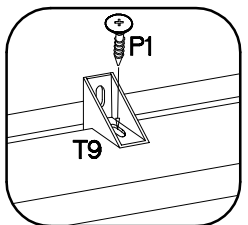
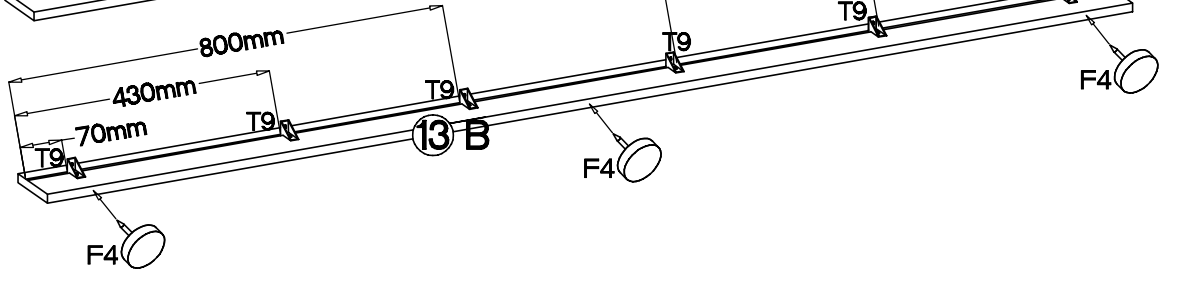
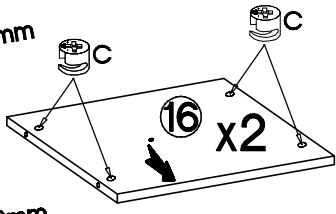
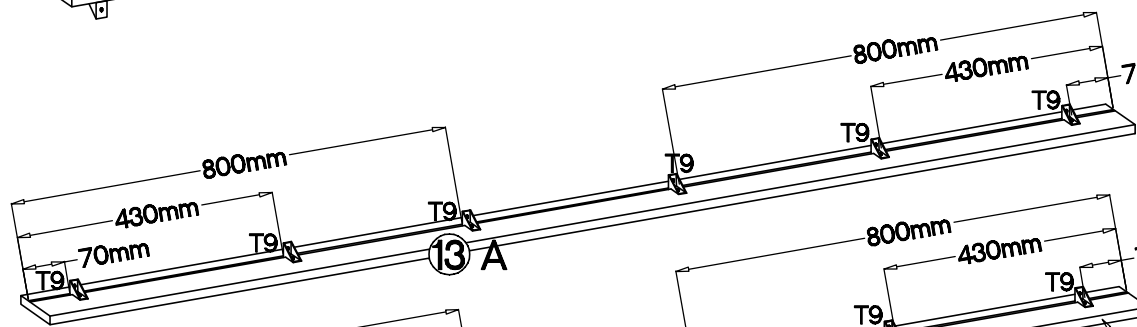
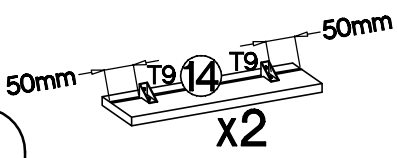
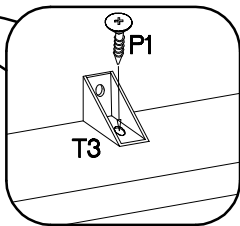
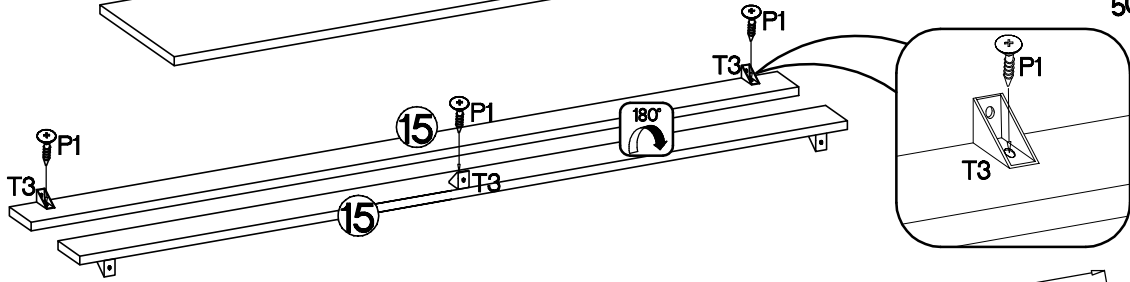
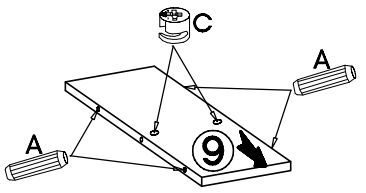
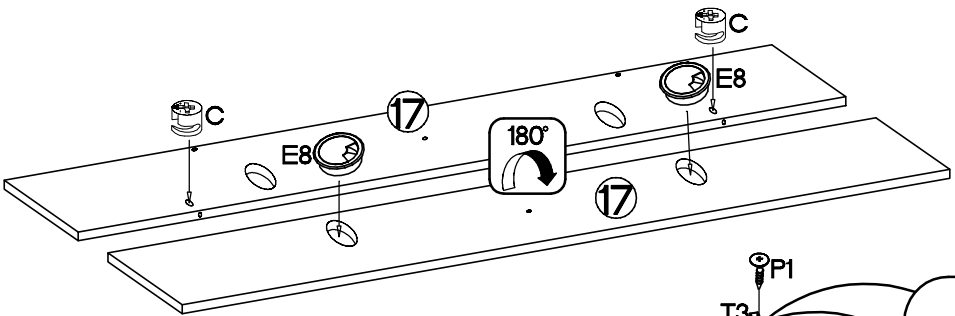
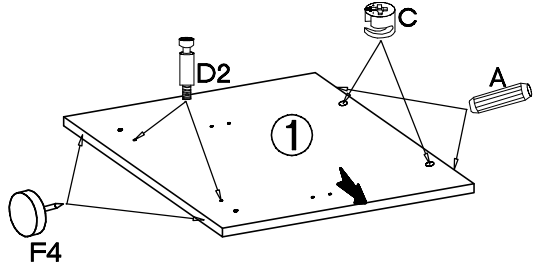
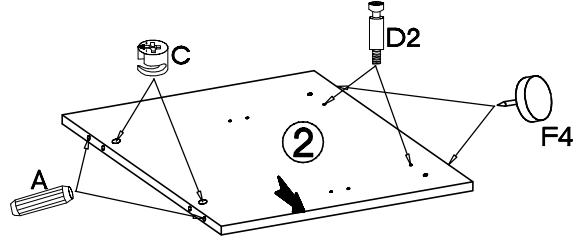
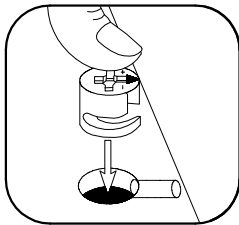
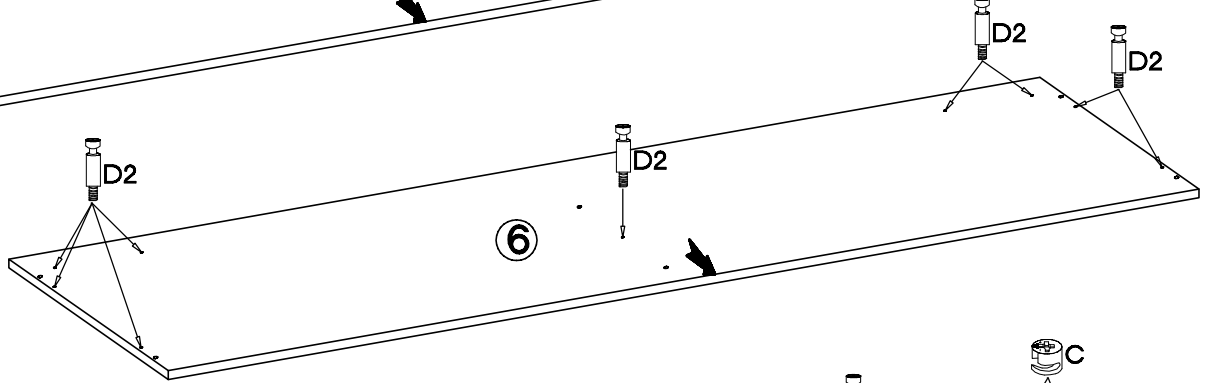
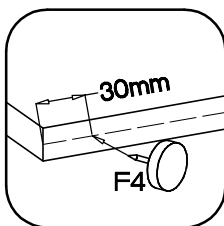
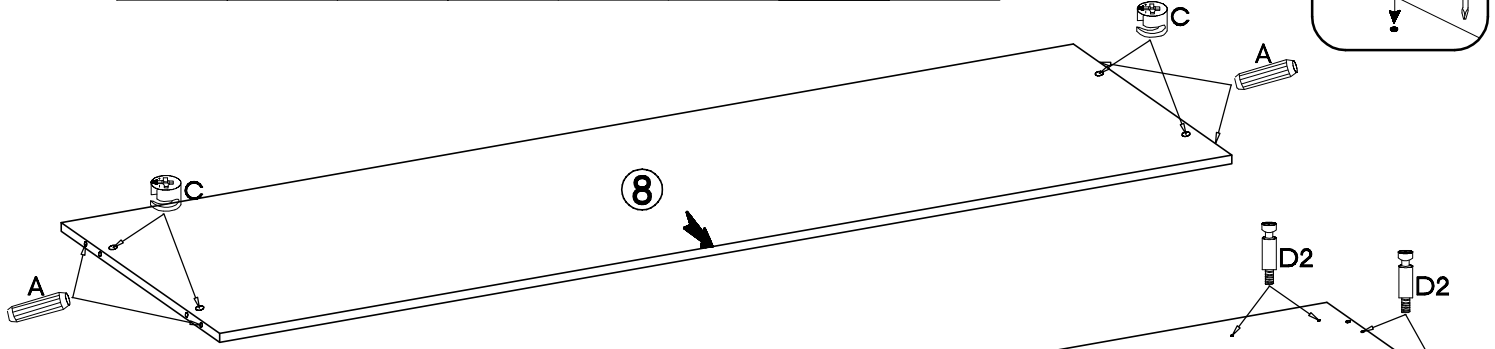
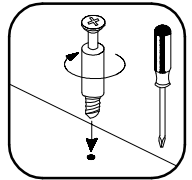

L-20mm  D2 13	#15/12mm  C 20	#8x30mm  A 12	#15x5mm  F4 7	#60  E8 2	#4.0x16mm  P1 19	 T9 16	 T3 3
--	---	--	--	--	---	--	--



8

 #4.0x16mm P1 3	 #15x5mm F4 3
--	--

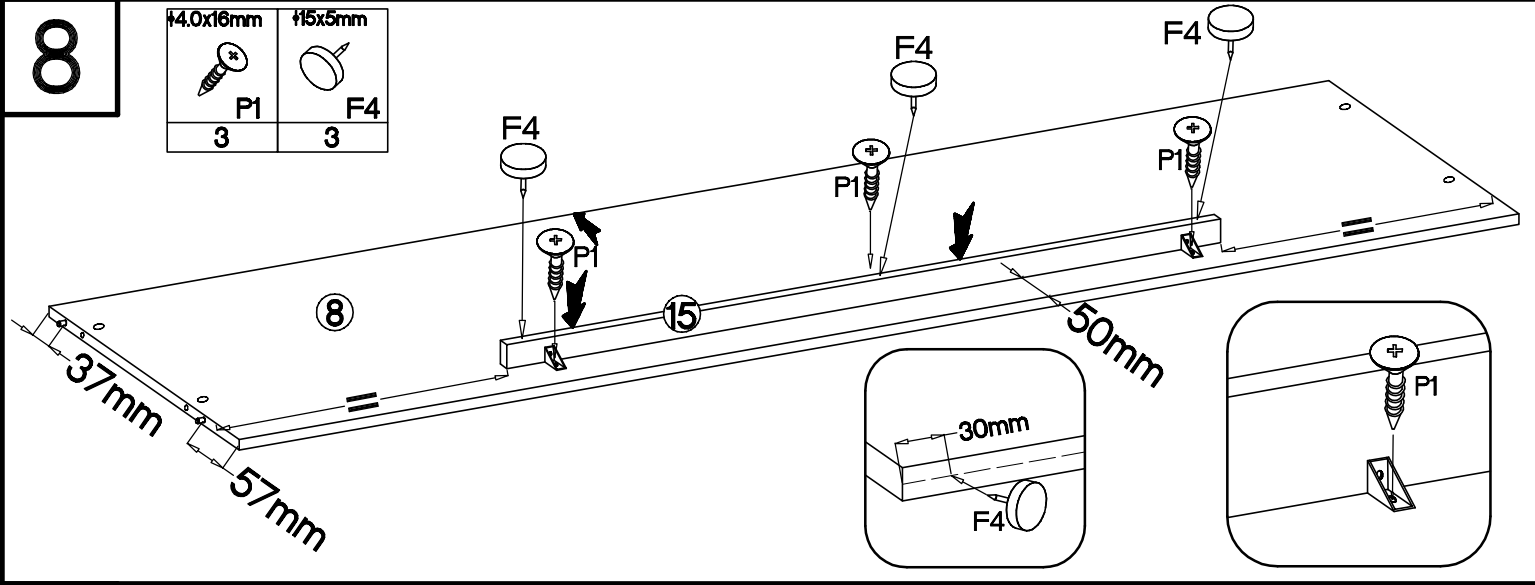

9

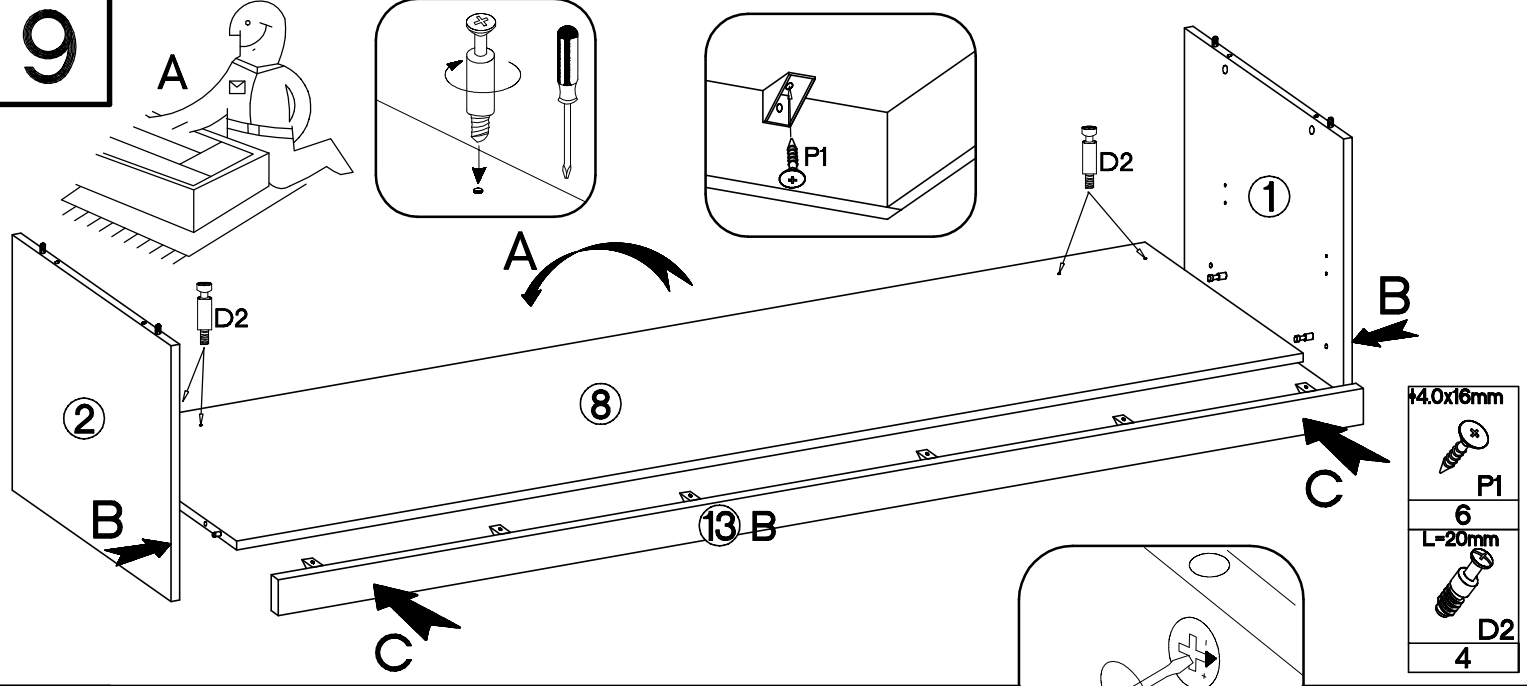
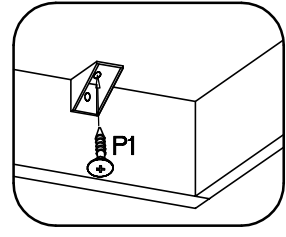
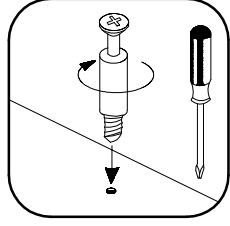
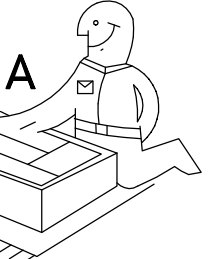

10

 #4.0x16mm P1 4

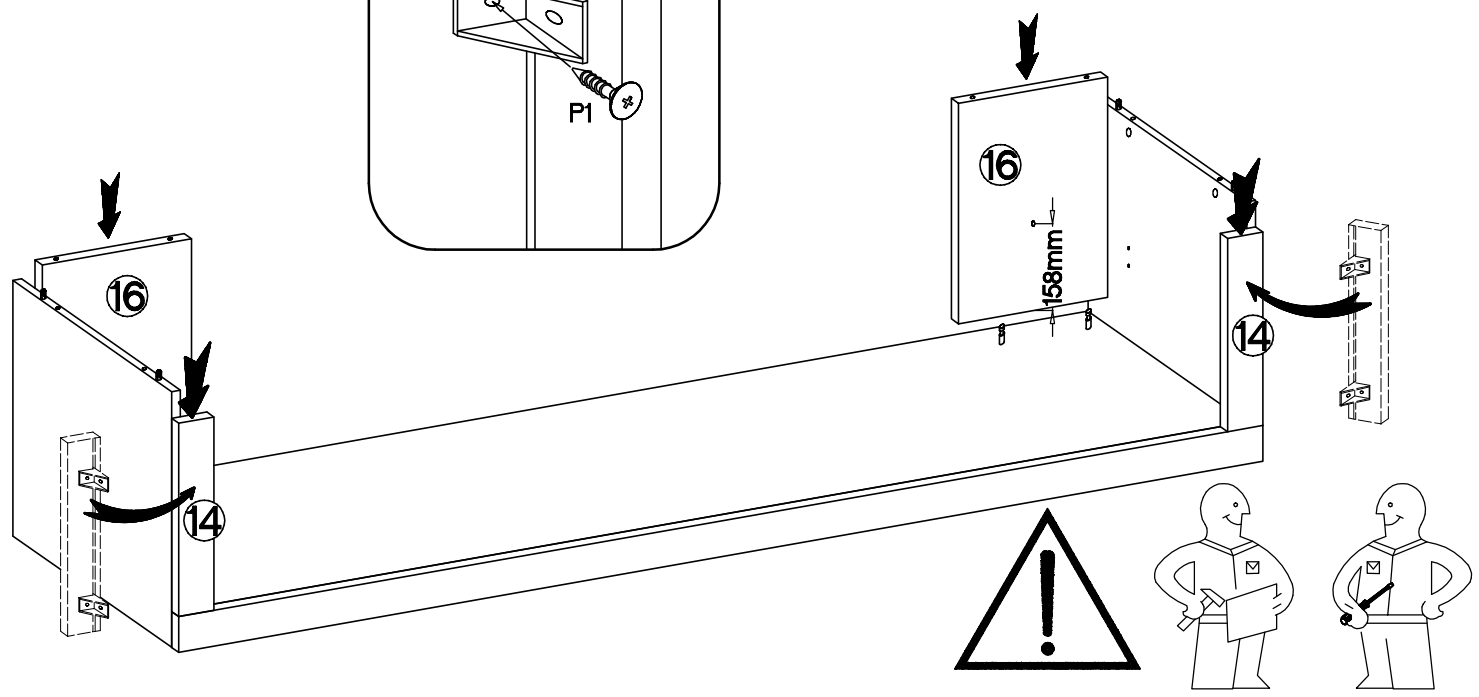
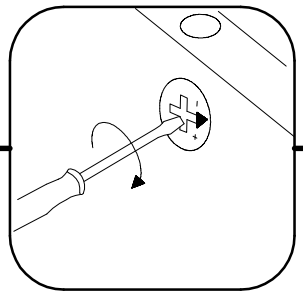
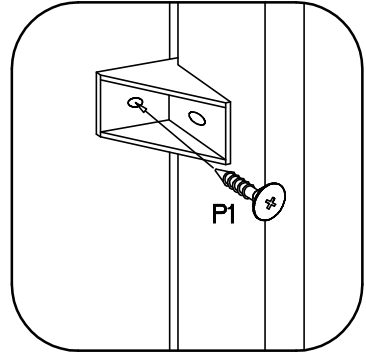

11

4.0x16mm

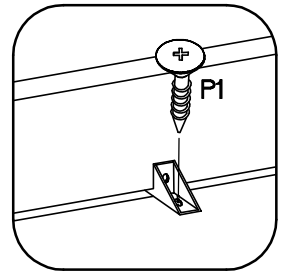
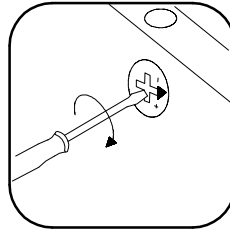
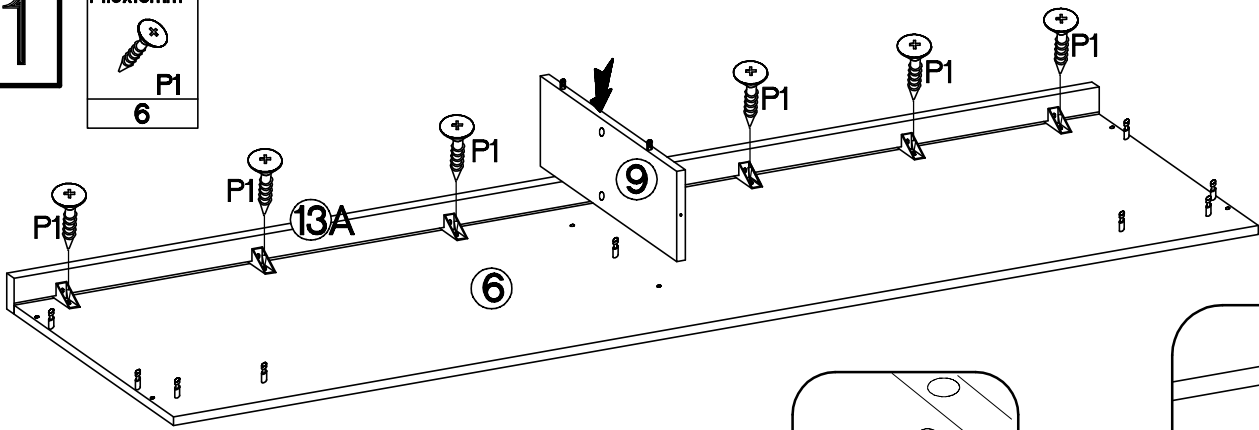
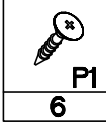

12

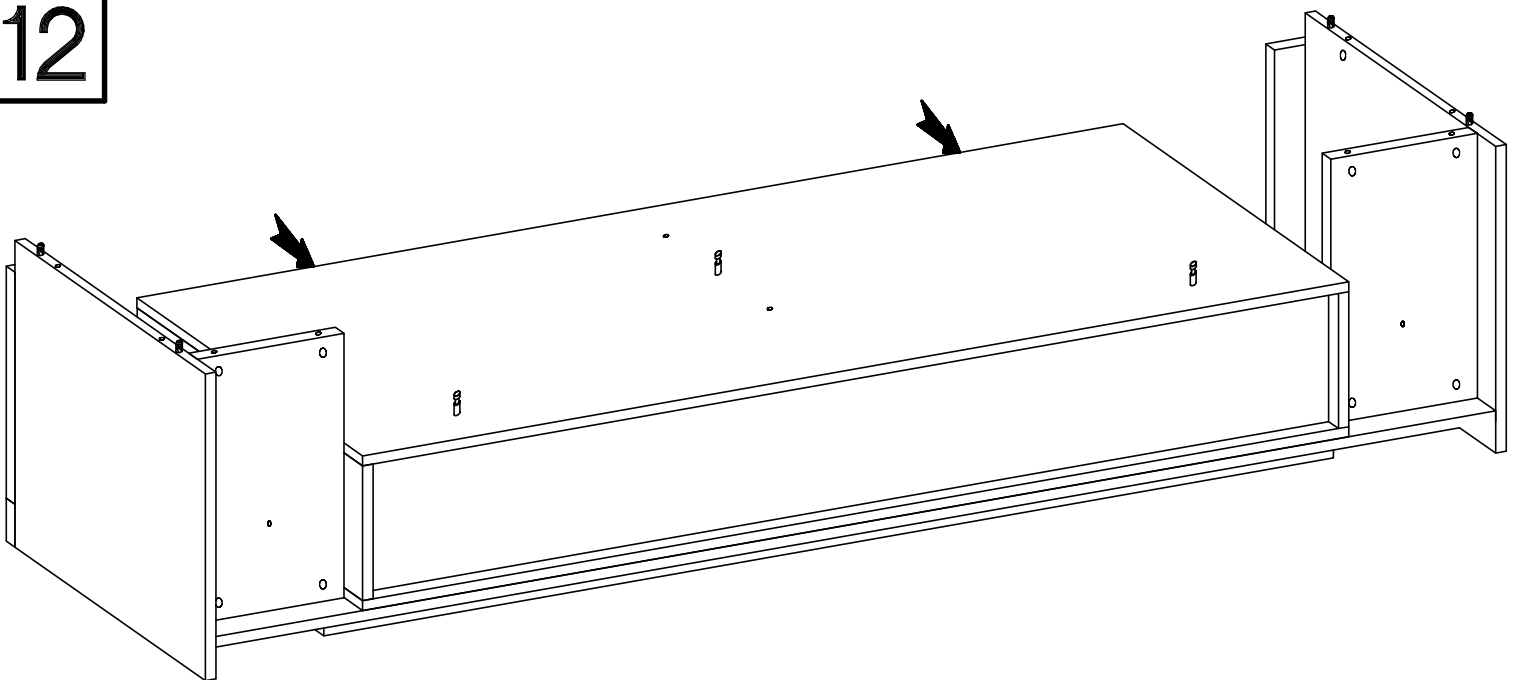

13

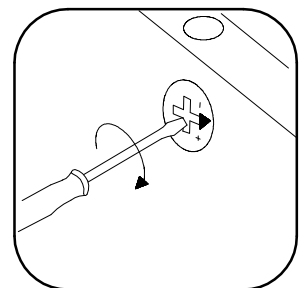
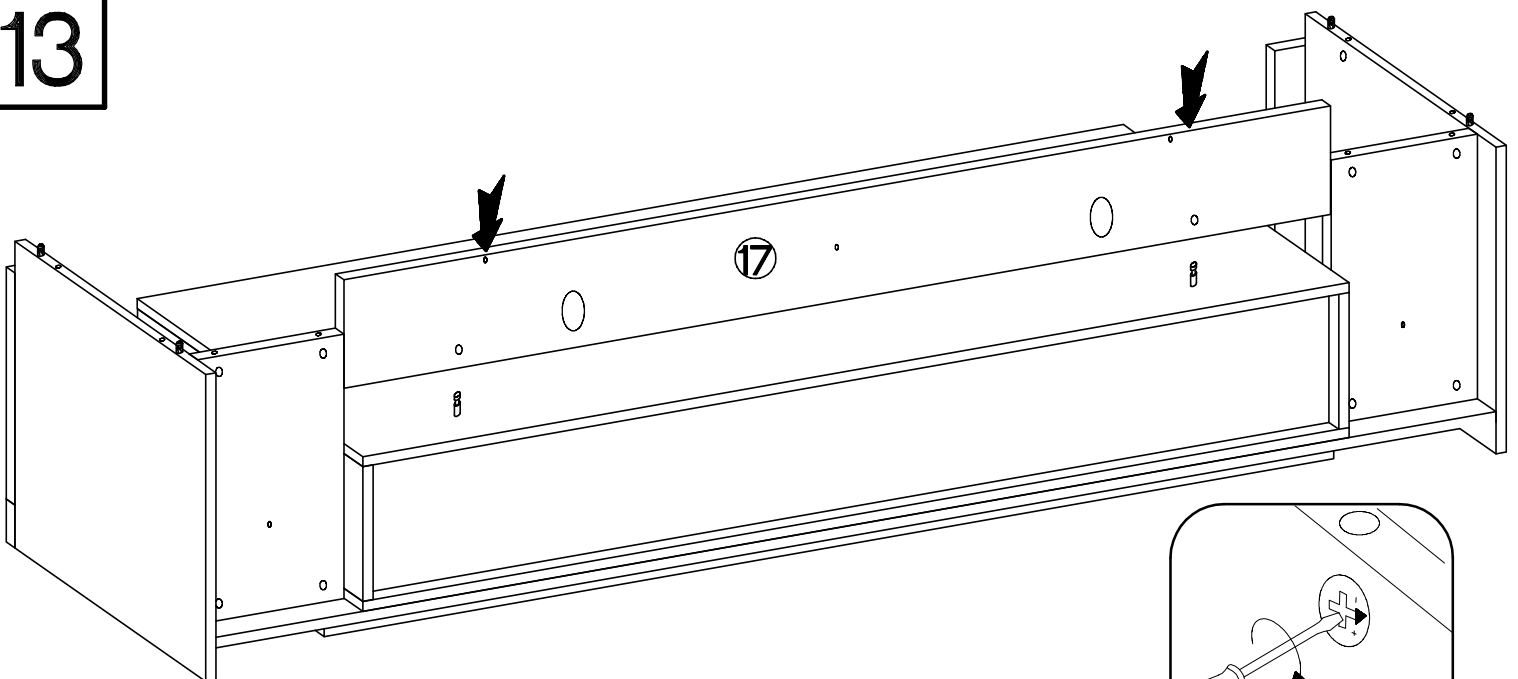

14

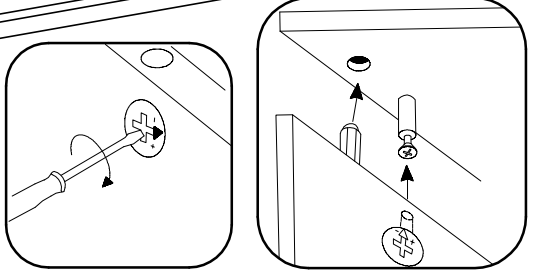
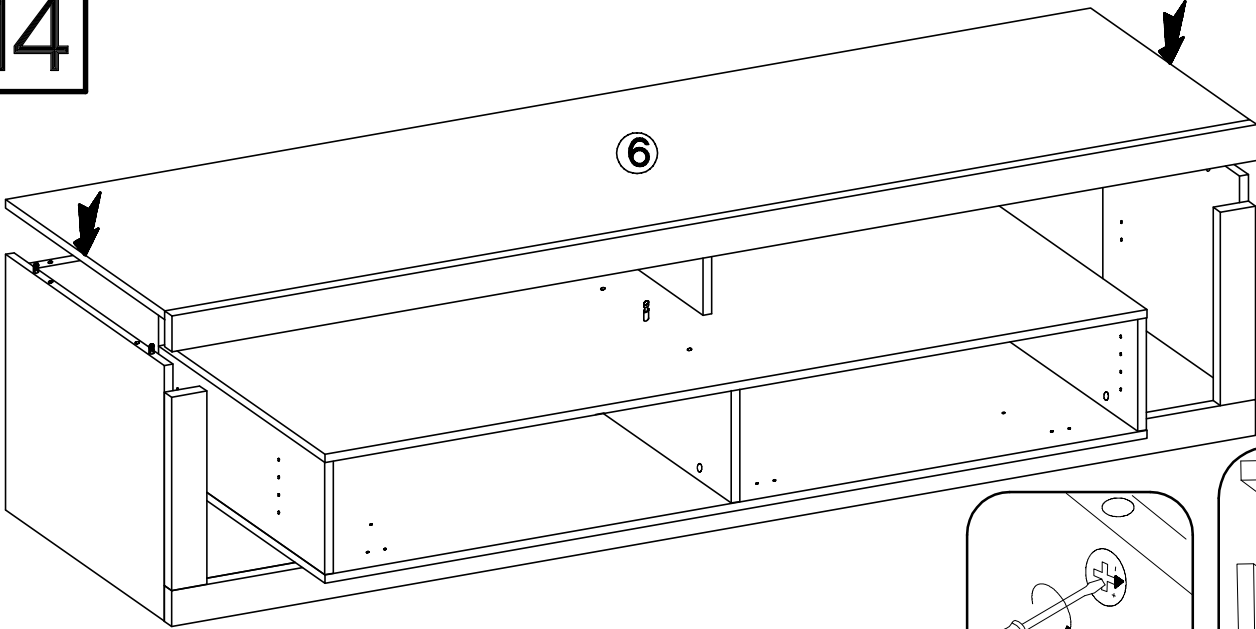

15

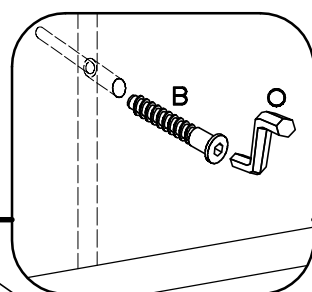
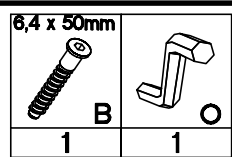
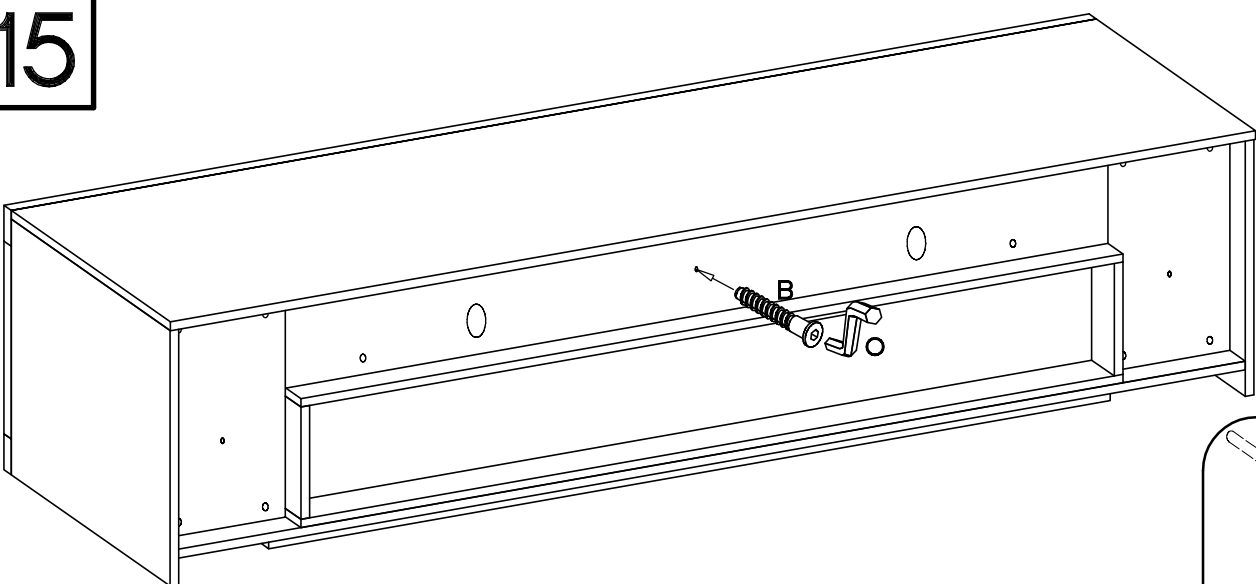

16

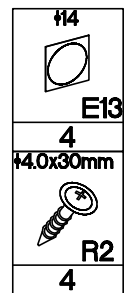
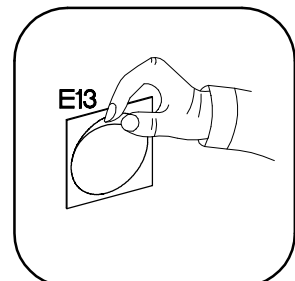
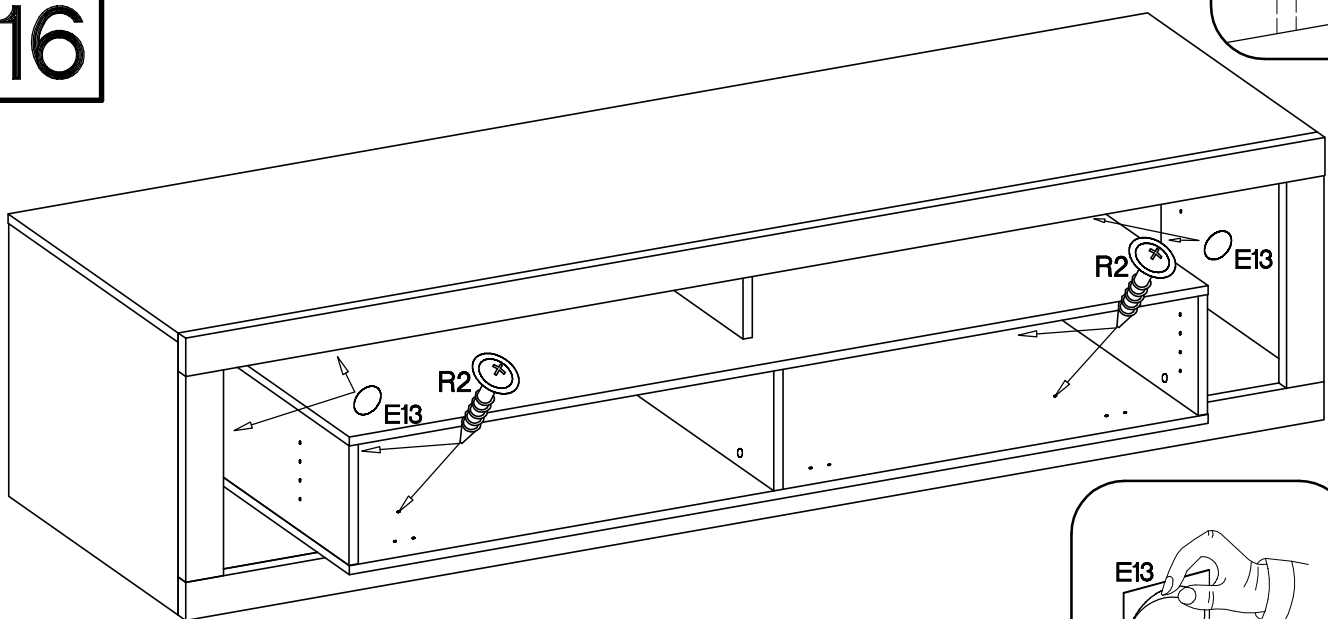

17

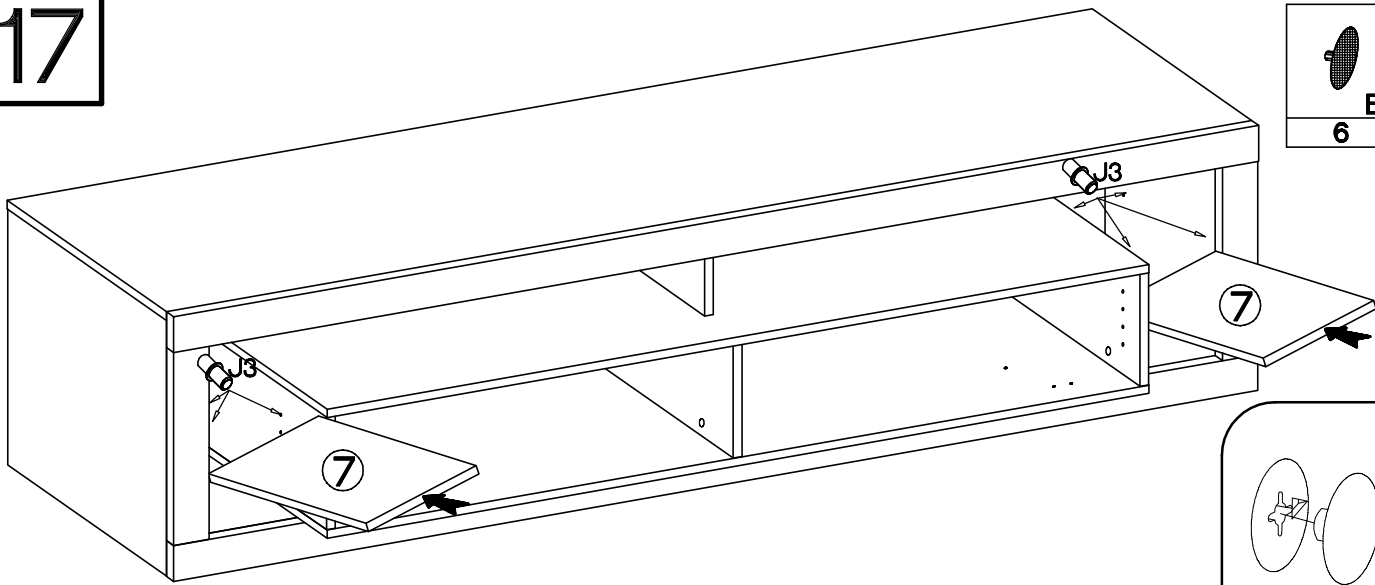

6	8
12	

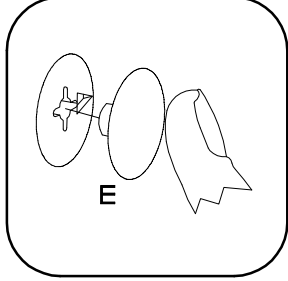

18

L-192mm	4.0x27mm	4.0x16mm
2	4	6

